



**THE DATASHEET OF
SSL5031CTS/1X**





SSL5031CTS

Compact high power factor/low-THD buck LED driver IC

Rev. 2 — 11 March 2015

Product data sheet

1. General description

The SSL5031CTS is a highly integrated, high-precision, non-isolated buck controller with external MOSFET. It is intended to drive LED lamps in universal mains non-dimmable lighting applications up to 25 W. The SSL5031CTS is designed for high power factor/low-THD applications.

The SSL5031CTS operates in Boundary Conduction Mode (BCM) with on-time regulation. Operating in BCM provides a constant output current control with high accuracy. Adaptive switching frequency gives freedom to choose the inductor, which enables the optimization of inductor size, efficiency and EMI.

The SSL5031CTS starts up and operates in switching mode directly from an external resistor without dV/dt supply or auxiliary supply. This feature simplifies the V_{CC} supply. It allows a low-cost off-the-shelf inductor to be used, providing flexibility in application design.

The SSL5031CTS comes in a compact TSOP6 package.

The SSL5031BTS is best suited for high power factor/low THD applications with a high-temperature foldback function. The SSL5021BTS is suitable for low-ripple applications.

2. Features and benefits

- Driving LED strings from a rectified mains supply, high power factor/low-THD
- Small electronic Bill of Materials (BOM) enabling a compact solution and a small, single layer Printed-Circuit Board (PCB) footprint
- Excellent line and load regulation and LED output current accuracy
- Efficient BCM operation with:
 - ◆ Minimal reverse recovery losses in freewheel diode
 - ◆ Zero Current Switching (ZCS) and valley switching for switch turn-on
 - ◆ Minimal inductance value and size required
 - ◆ High efficiency (up to 91 %)
 - ◆ Ultra low IC current during operation ($< 150 \mu\text{A}$)
- Auto-recovery protections:
 - ◆ UnderVoltage LockOut (UVLO)
 - ◆ Cycle-by-cycle OverCurrent Protection (OCP)
 - ◆ Internal OverTemperature Protection (OTP)
 - ◆ Output OverVoltage Protection (OVP)



- ◆ Output Short Protection (OSP)
- Compatible with wall switches with built-in standby indicator lights (Hotaru switch)
- Extended IC lifetime

3. Applications

- The SSL5031CTS is intended for low-cost, non-isolated LED lighting applications with accurate fixed current output up to 25 W for single mains or universal mains voltage (90 V (AC) to 277 V (AC)).

4. Quick reference data

Table 1. Quick reference data

Symbol	Parameter	Conditions	Min	Typ	Max	Unit
V _{CC}	supply voltage	operating range [1]	9.5	-	16	V
R _{DSon}	on-state resistance	of internal switch				
		T _j = 25 °C	-	0.75	0.90	Ω
		T _j = 125 °C	-	1.20	-	Ω
I _{I(SW)}	input current in pin SW	triangle wave; duty cycle < 20 %	-2	-	+2	A
V _{I(SW)}	input voltage on pin SW	current limited at 8.8 mA; internal switch off	-0.4	-	+22	V

[1] An internal clamp sets the supply voltage. The current into the VCC pin must not exceed the maximum I_{VCC} value (see [Table 4](#)).

5. Ordering information

Table 2. Ordering information

Type number	Package		Version
	Name	Description	
SSL5031CTS	TSOP6	plastic surface-mounted package; 6 leads	SOT457

6. Block diagram

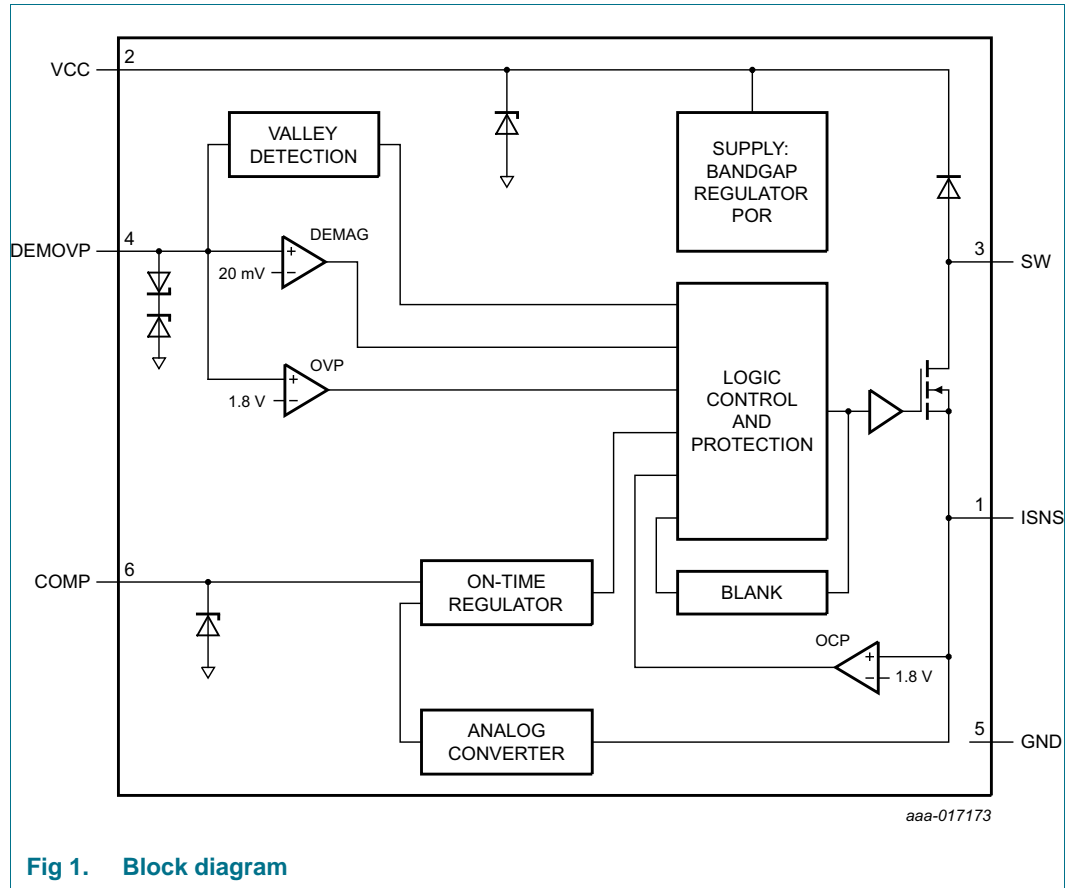

7. Pinning information

7.1 Pinning

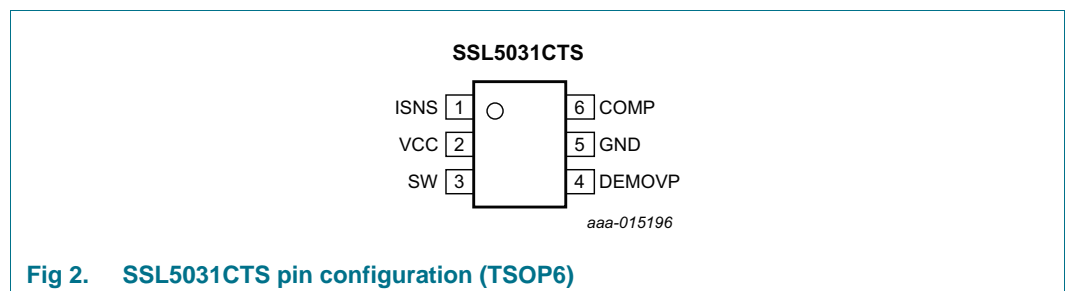

$$I_L = \frac{V_{intregd(AV)ISNS}}{R4 + 0.09 \times \delta} \tag{1}$$

Where:

- 0.09 = ISNS bond wire resistance.
- δ is the buck topology duty cycle.

8.3 Valley detection

After I_L has decreased to zero at t_3 , the LEDP voltage starts to oscillate around the bus voltage (V_{IN}) minus output voltage level (V_{OUT}), with amplitude output voltage (V_{OUT}) and frequency (f_{ring}). Valley detection is a special circuit that is integrated in the SSL5031CTS. It senses when the LEDP voltage reaches its lowest level (valley) through DEMOVP pin connection. If a valley is detected, the internal switch is switched on again. As a result, the switch-on switching losses are reduced.

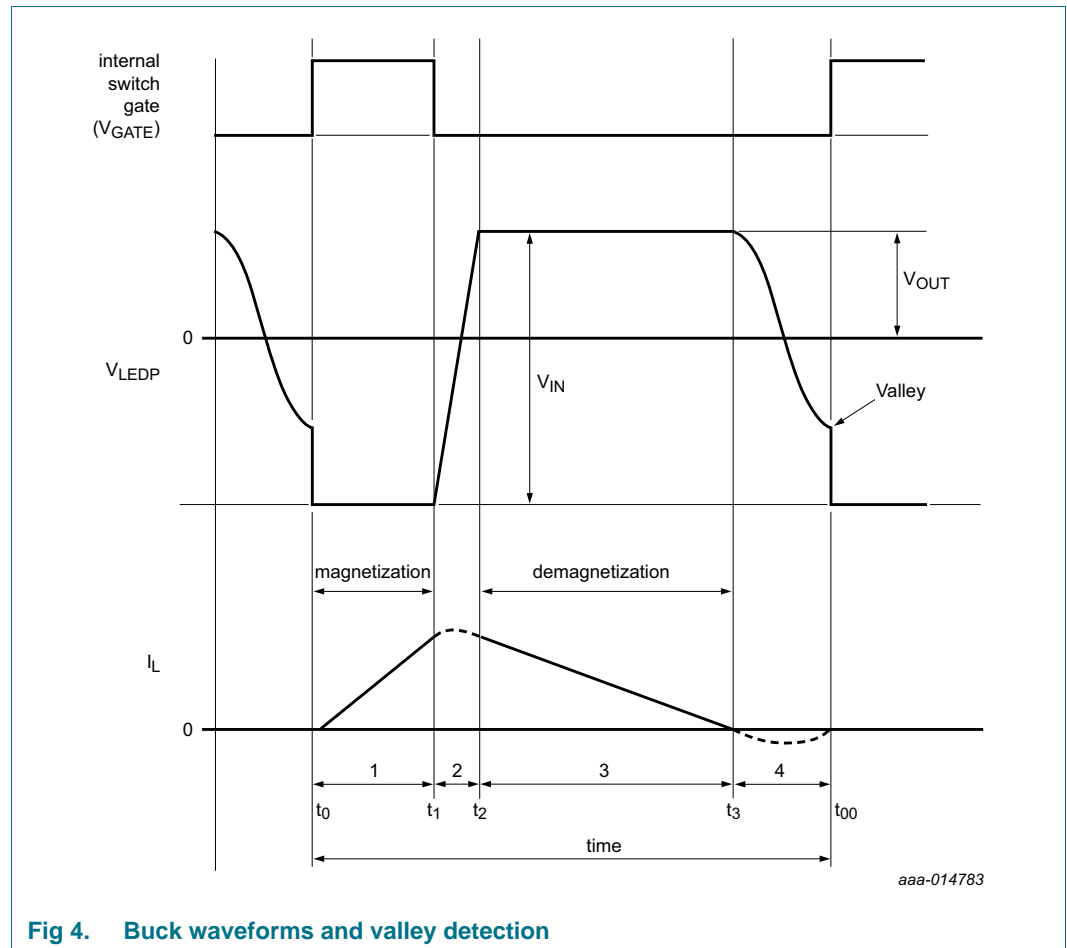

Fig 4. Buck waveforms and valley detection

8.4 Start-up current

The supply current for the IC is supplied by resistors R3. the IC draws an additional start-up current ($I_{CC(startup)}$) just before V_{CC} reaches the start-up voltage level ($V_{startup}$). So the supply current in operating mode is lower than during start-up conditions, preventing

lamp flicker when the mains voltage is increased or decreased slowly. [Figure 5](#) shows the basic behavior.

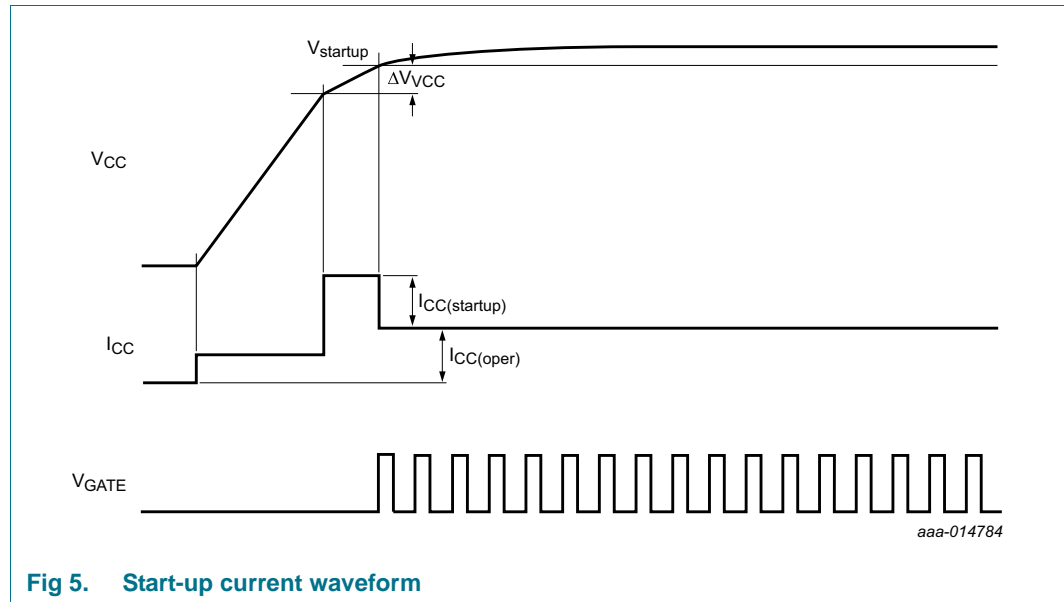

Fig 5. Start-up current waveform

8.5 Leading-Edge Blanking (LEB)

To prevent false detection of overcurrent, a blanking time following switch-on is implemented. When the internal switch turns on, a short current spike can occur because of the discharge capacitance of the MOSFET (Q1) drain node.

8.6 Magnetization switching

When the mains voltage is very low around the zero crossing of the mains, the system hardly delivers any energy to the LED. To improve efficiency, the maximum off-time ($T_{off(max)}$) switching limits the switching frequency to < 25 kHz. A peak voltage on the ISNS pin below the $V_{I(min)ISNS}$ voltage indicates a low mains voltage.

8.7 Protections

The IC incorporates the following protections:

- UnderVoltage LockOut (UVLO)
- Cycle-by-cycle OverCurrent Protection (OCP)
- Internal OverTemperature Protection (OTP)
- Cycle-by-cycle maximum on-time protection
- Output OverVoltage Protection
- Output Short Protection (OSP)

8.7.1 UnderVoltage LockOut (UVLO)

When voltage on VCC pin drops to below $V_{th(UVLO)}$, the IC stops switching. An attempt is made to restart IC when the voltage on the VCC pin > $V_{startup}$.

8.7.2 Cycle-by-cycle OverCurrent Protection (OCP)

The SSL5031CTS incorporates a built-in peak current detector. It triggers when the voltage at the ISNS pin reaches the peak level $V_{I(max)ISNS}$. A resistor connected to ISNS pin senses the current through inductor I_L . The maximum current in inductor, $I_{L(max)}$ equals:

$$I_{L(max)} = \frac{V_{I(max)ISNS}}{R4 + 0.09} \quad (2)$$

The sense circuit is activated after the leading-edge blanking time (t_{leb}). Because the LED current is half the peak current by design, the sense circuit automatically provides protection for the maximum LED current during operation. A propagation delay exists between the overcurrent detection and the actual switch switch-off. Due to this delay, the actual peak current is slightly higher than the OCP level set by the resistor connected in series with the ISNS pin.

8.7.3 OverTemperature Protection (OTP)

The converter stops switching when the internal OTP function is triggered at the IC junction temperature $T_{pl(IC)}$. The safe-restart protection is triggered and the IC resumes switching when the IC temperature drops to below $T_{rst(IC)}$.

8.7.4 Cycle-by-cycle maximum on-time protection

Measuring the inductor current I_L using sense resistor R4 regulates the on-time. The on-time is limited to a fixed value ($t_{on(max)}$). It protects the system and the IC when the ISNS pin is shorted or when the system works at very low mains voltage.

8.7.5 Output OverVoltage Protection (OVP)

An accurate output OVP is implemented by measuring the voltage at the DEMOVP pin during the secondary stroke. The resistive divider connected between the LEDP node and the DEMOVP pin sets the maximum LED voltage.

An internal counter prevents false OVP detection because of noise on the DEMOVP pin. After three continuous cycles with a DEMOVP pin voltage above the OVP level, the OVP protection is triggered.

The over voltage protection triggers a restart sequence: A discharge current ($I_{CC(dch)}$) is enabled and discharges the voltage on the VCC pin to below $V_{rst(latch)}$. When $V_{rst(latch)}$ is reached, the system restarts.

8.7.6 Output Short Protection (OSP)

The converter operates in Discontinuous Conduction Mode (DCM). A new cycle is only started after the previous cycle has ended. The end of the cycle is detected by measuring the voltage on the DEMOVP pin. When the DEMOVP pin voltage drops to below the demagnetization level ($V_{th(comp)DEMOVP}$) and a valley is detected, a new cycle starts. When output is shorted, the demagnetization is not finalized within the 40 μ s. The converter still regulates the adjusted output current and the on-time is reduced to a safe value by this feedback. The reduced on-time in combination with very long demagnetization time prevents that the converter is damaged or excessive dissipation occurs.

A blanking time ($t_{\text{sup(xfmr_ring)}}$) is implemented at the start of the secondary stroke to prevent false demagnetization detection.

8.8 Supply management

The IC starts up when the voltage on the VCC pin increases to exceed V_{startup} . The IC locks out (stops switching) when the voltage on the VCC pin drops to below $V_{\text{th(UVLO)}}$. The hysteresis between the start and stop levels allows the VCC capacitor to supply the IC during zero-crossings of the mains.

The SSL5031CTS incorporates an internal clamping circuit to limit the voltage on the VCC pin. The clamp limits the voltage on the VCC pin to the maximum value, $V_{\text{clamp(VCC)}}$. If the maximum current of the external resistor minus the current consumption of the IC is lower than the limiting value of I_{VCC} in [Table 4](#), no external Zener diode is required.

9. Limiting values

Table 4. Limiting values

In accordance with the Absolute Maximum Rating System (IEC 60134).

Symbol	Parameter	Conditions	Min	Max	Unit
Voltages					
V _{CC}	supply voltage	current limited [1] [2]	-0.4	+18	V
V _{I(SW)}	input voltage on pin SW	current limited to 8.8 mA; internal switch off	[2] -0.4	+22	V
V _{I(ISNS)}	input voltage on pin ISNS		-0.4	+5	V
V _{IO(COMP)}	input/output voltage on pin COMP		-0.4	+5.3	V
V _{I(DEMOVP)}	input voltage on pin DEMOVP		-6	+6	V
Currents					
I _{I(VCC)}	input current on pin VCC		-	8.8	mA
I _{I(SW)}	input current on pin SW	RMS current	-	380	mA
		triangle wave; duty cycle < 20 %	-2	+2	A
I _{I(ISNS)}	input current on pin ISNS	triangle wave; duty cycle < 20 %	-2	+2	A
General					
P _{tot}	total power dissipation	T _{amb} < 75 °C	-	0.28	W
T _{stg}	storage temperature		-55	+150	°C
T _j	junction temperature		-40	+160	°C
ESD					
ESD	electrostatic discharge	class 1			
		human body model [3]	-2000	+2000	V
		charged device model [4]	-500	+500	V

[1] The current into the VCC pin must not exceed the maximum I_{I(VCC)} value.

[2] An internal clamp sets the supply voltage and current limits.

[3] Equivalent to discharge a 100 pF capacitor through a 1.5 kΩ series resistor.

[4] Charged device model: equivalent to charging the IC up to 1 kV and the subsequent discharging of each pin down to 0 V over a 1 Ω resistor.

10. Thermal characteristics

Table 5. Thermal characteristics

Symbol	Parameter	Conditions	Typ	Unit
R _{th(j-a)}	thermal resistance from junction to ambient	In free air; JEDEC test board	259	K/W
R _{th(j-c)}	thermal resistance from junction to case	In free air; JEDEC test board	152	K/W

11. Characteristics

Table 6. Characteristics

$T_{amb} = 25\text{ °C}$; $V_{CC} = 15\text{ V}$; all voltages are measured with respect to ground pin (pin 5); currents are positive when flowing into the IC; unless otherwise specified.

Symbol	Parameter	Conditions	Min	Typ	Max	Unit
Supply (pin VCC)						
$V_{startup}$	start-up voltage		12.25	12.65	13.05	V
$V_{th(UVLO)}$	undervoltage lockout threshold voltage		9.6	9.9	10.2	V
ΔV_{VCC}	voltage difference on pin VCC		0.17	0.30	0.43	V
$V_{clamp(VCC)}$	clamp voltage on pin VCC	$I_{I(VCC)} = 2.6\text{ mA}$ [1]	15.2	15.8	16.4	V
$V_{rst(latch)}$	latched reset voltage		6.0	6.2	6.4	V
$I_{CC(oper)}$	operating supply current	switching at 100 kHz	100	125	150	μA
$I_{CC(startup)}$	start-up supply current		120	145	170	μA
$I_{CC(dch)}$	discharge supply current	$V_{CC} = V_{rst(latch)}$	3.7	4.8	5.5	mA
Loop compensation (pin COMP)						
$V_{ton(zero)COMP}$	zero on-time voltage on pin COMP		1.96	2.04	2.12	V
$V_{ton(max)COMP}$	maximum on-time voltage on pin COMP		3.8	4.0	4.2	V
$V_{clamp(COMP)}$	clamp voltage on pin COMP		4.3	4.7	5.1	V
$t_{on(max)}$	maximum on-time	$V_{IO(COMP)} = 4\text{ V}$	12.3	15.5	18.7	μs
$I_{O(COMP)}$	output current on pin COMP	$V_{I(ISNS)} = 0\text{ V}$	3.2	4.0	4.8	μA
Valley detection and overvoltage detection (pin DEMOVP)						
$I_{prot(DEMOVP)}$	protection current on pin DEMOVP	open current; $V_{I(DEMOVP)} = 0\text{ V}$	-250	-180	-50	nA
$V_{th(ovp)}$	overvoltage protection threshold voltage		1.74	1.81	1.88	V
$N_{cy(ovp)}$	number of overvoltage protection cycles		-	3	-	-
$g_{mDEMOVP}$	transconductance on pin DEMOVP	$V_{I(DEMOVP)}$ to $I_{O(COMP)}$	24	29	34	$\mu\text{A/V}$
$V_{th(comp)DEMOVP}$	comparator threshold voltage on pin DEMOVP		4	18	32	mV
$(dV/dt)_{vrec}$	valley recognition voltage change with time	[2]	-	-3.8		V/ μs
$t_{sup(xmfr_ring)}$	transformer ringing suppression time		1.2	1.5	1.8	μs
Current sensing (pin ISNS)						
$V_{I(min)ISNS}$	minimum input voltage on pin ISNS		75	100	125	mV
$V_{I(max)ISNS}$	maximum input voltage on pin ISNS		1.7	1.8	1.9	V
$t_{on(min)}$	minimum on-time	[3]	310	410	510	ns
t_d	delay time	[2][4]	-	100	-	ns

Table 6. Characteristics ...continued

$T_{amb} = 25\text{ °C}$; $V_{CC} = 15\text{ V}$; all voltages are measured with respect to ground pin (pin 5); currents are positive when flowing into the IC; unless otherwise specified.

Symbol	Parameter	Conditions	Min	Typ	Max	Unit
gm_{ISNS}	transconductance on pin ISNS	$V_{I(ISNS)}$ to $I_{O(COMP)}$	8.4	9.7	11.0	$\mu\text{A/V}$
$V_{intregd(AV)ISNS}$	average internal regulated voltage on pin ISNS		0.396	0.410	0.424	V
Driver (pin SW)						
R_{DSon}	on-state resistance	$T_j = 25\text{ °C}$	-	0.75	0.90	Ω
		$T_j = 125\text{ °C}$	-	1.20	-	Ω
$t_{off(max)}$	maximum turn-off time		30	40	50	μs
Temperature protection						
$T_{p(IC)}$	IC protection level temperature		140	150	165	$^{\circ}\text{C}$
$T_{rst(IC)}$	IC reset level temperature		106	118	130	$^{\circ}\text{C}$

- [1] The start-up voltage and the clamp voltage are correlated.
- [2] Guaranteed by design.
- [3] The minimum on-time is only effective when OCP is triggered.
- [4] $t_{leb} = t_{on(min)} - t_d$

12. Application information

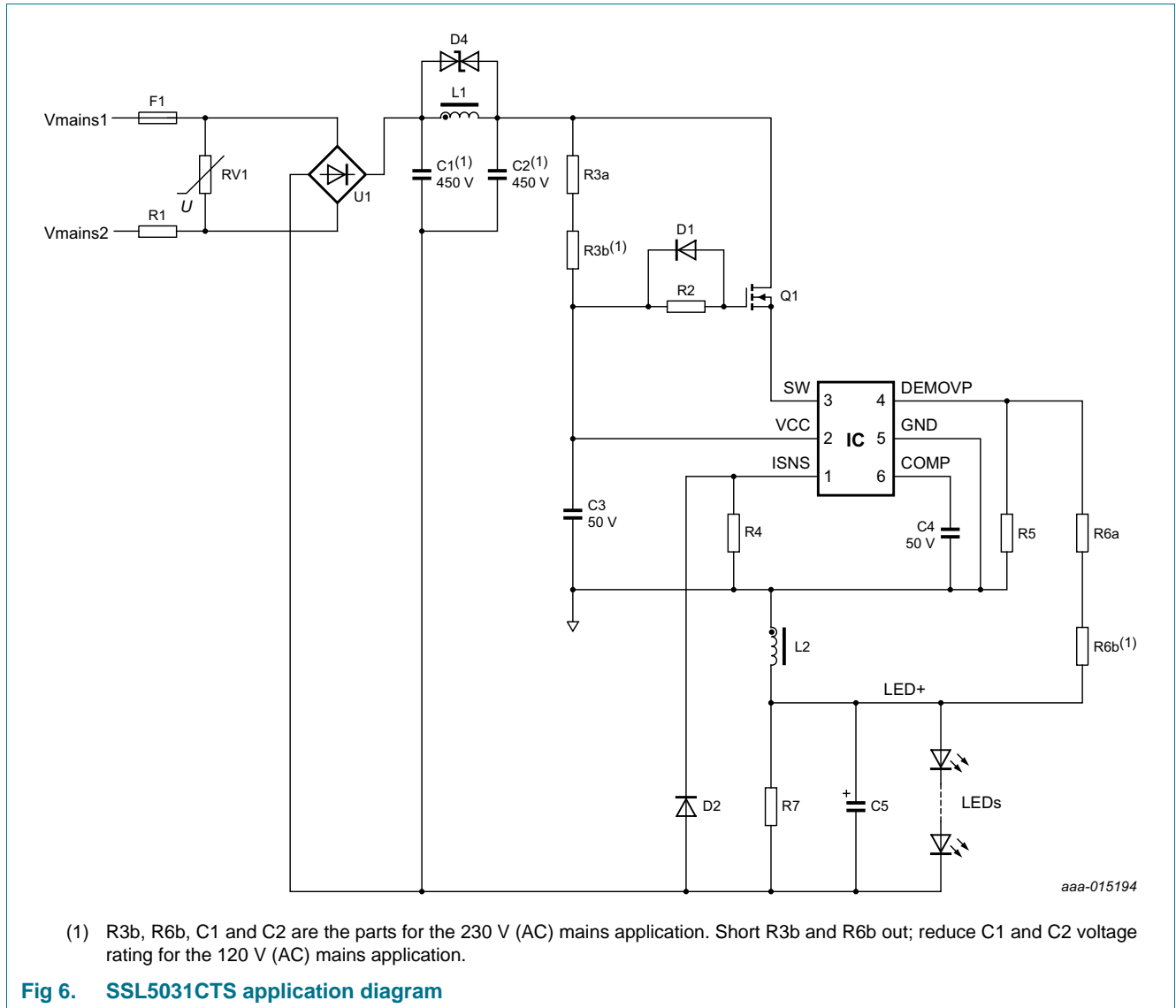

13. Package outline

Plastic surface-mounted package (TSOP6); 6 leads

SOT457

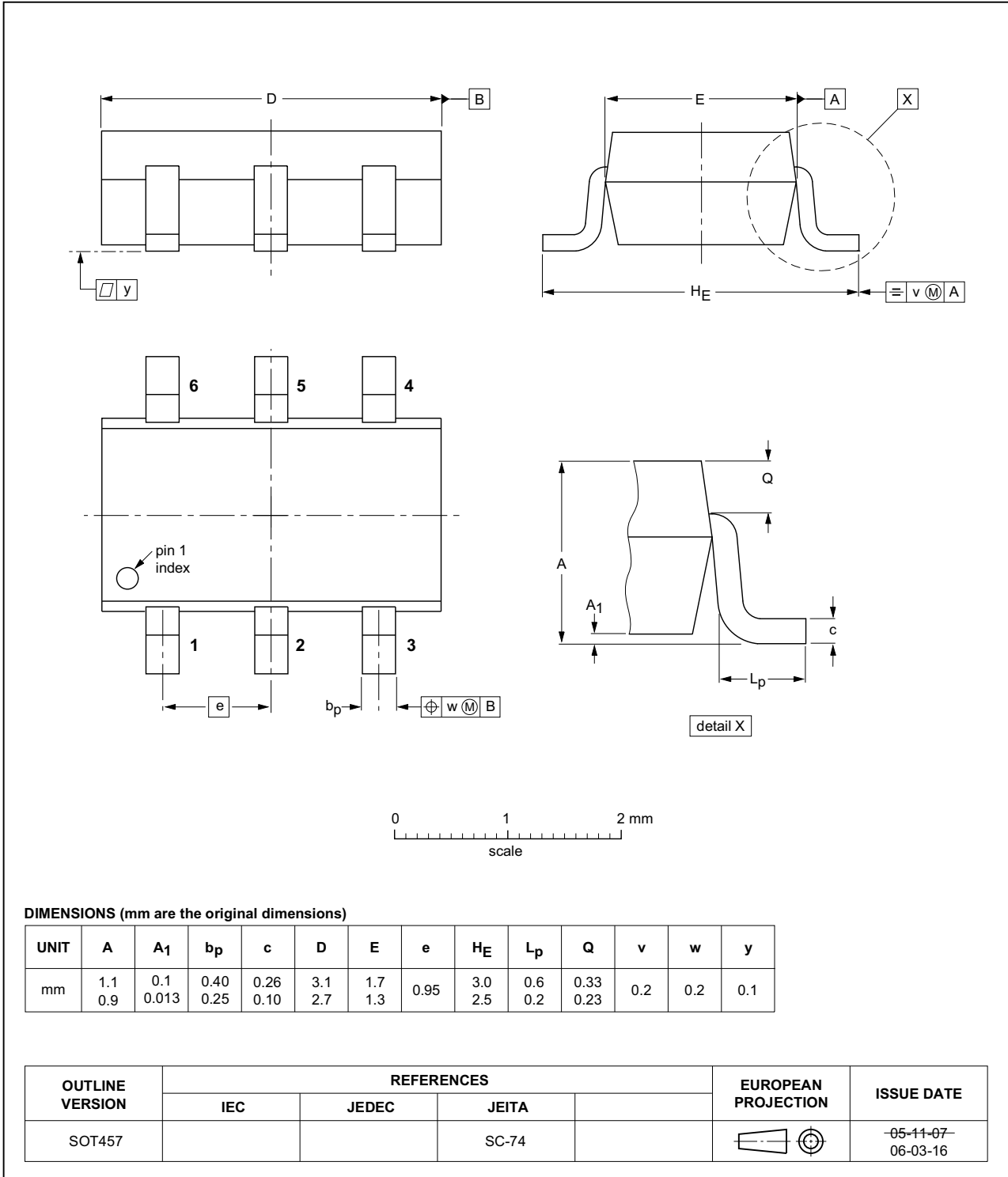

Fig 7. Package outline SOT457 (TSOP6)

14. Abbreviations

Table 7. Abbreviations

Acronym	Description
BCM	Boundary Conduction Mode
BOM	Bill Of Materials
LEB	Leading-Edge Blanking
OCP	OverCurrent Protection
OSP	Output Short Protection
OTP	OverTemperature Protection
OVP	OverVoltage Protection
PCB	Printed-Circuit Board
UVLO	UnderVoltage LockOut
ZCS	Zero Current Switching

15. Revision history

Table 8. Revision history

Document ID	Release date	Data sheet status	Change notice	Supersedes
SSL5031CTS v.2	20150311	Product data sheet	-	SSL5031CTS v.1
Modifications:	<ul style="list-style-type: none">• The data sheet status has changed from Preliminary to Product.• Text and graphics have been updated throughout the data sheet.			
SSL5031CTS v.1	20141015	Preliminary data sheet	-	-

16. Legal information

16.1 Data sheet status

Document status ^{[1][2]}	Product status ^[3]	Definition
Objective [short] data sheet	Development	This document contains data from the objective specification for product development.
Preliminary [short] data sheet	Qualification	This document contains data from the preliminary specification.
Product [short] data sheet	Production	This document contains the product specification.

[1] Please consult the most recently issued document before initiating or completing a design.

[2] The term 'short data sheet' is explained in section "Definitions".

[3] The product status of device(s) described in this document may have changed since this document was published and may differ in case of multiple devices. The latest product status information is available on the Internet at URL <http://www.nxp.com>.

16.2 Definitions

Draft — The document is a draft version only. The content is still under internal review and subject to formal approval, which may result in modifications or additions. NXP Semiconductors does not give any representations or warranties as to the accuracy or completeness of information included herein and shall have no liability for the consequences of use of such information.

Short data sheet — A short data sheet is an extract from a full data sheet with the same product type number(s) and title. A short data sheet is intended for quick reference only and should not be relied upon to contain detailed and full information. For detailed and full information see the relevant full data sheet, which is available on request via the local NXP Semiconductors sales office. In case of any inconsistency or conflict with the short data sheet, the full data sheet shall prevail.

Product specification — The information and data provided in a Product data sheet shall define the specification of the product as agreed between NXP Semiconductors and its customer, unless NXP Semiconductors and customer have explicitly agreed otherwise in writing. In no event however, shall an agreement be valid in which the NXP Semiconductors product is deemed to offer functions and qualities beyond those described in the Product data sheet.

16.3 Disclaimers

Limited warranty and liability — Information in this document is believed to be accurate and reliable. However, NXP Semiconductors does not give any representations or warranties, expressed or implied, as to the accuracy or completeness of such information and shall have no liability for the consequences of use of such information. NXP Semiconductors takes no responsibility for the content in this document if provided by an information source outside of NXP Semiconductors.

In no event shall NXP Semiconductors be liable for any indirect, incidental, punitive, special or consequential damages (including - without limitation - lost profits, lost savings, business interruption, costs related to the removal or replacement of any products or rework charges) whether or not such damages are based on tort (including negligence), warranty, breach of contract or any other legal theory.

Notwithstanding any damages that customer might incur for any reason whatsoever, NXP Semiconductors' aggregate and cumulative liability towards customer for the products described herein shall be limited in accordance with the *Terms and conditions of commercial sale* of NXP Semiconductors.

Right to make changes — NXP Semiconductors reserves the right to make changes to information published in this document, including without limitation specifications and product descriptions, at any time and without notice. This document supersedes and replaces all information supplied prior to the publication hereof.

Suitability for use — NXP Semiconductors products are not designed, authorized or warranted to be suitable for use in life support, life-critical or safety-critical systems or equipment, nor in applications where failure or malfunction of an NXP Semiconductors product can reasonably be expected to result in personal injury, death or severe property or environmental damage. NXP Semiconductors and its suppliers accept no liability for inclusion and/or use of NXP Semiconductors products in such equipment or applications and therefore such inclusion and/or use is at the customer's own risk.

Applications — Applications that are described herein for any of these products are for illustrative purposes only. NXP Semiconductors makes no representation or warranty that such applications will be suitable for the specified use without further testing or modification.

Customers are responsible for the design and operation of their applications and products using NXP Semiconductors products, and NXP Semiconductors accepts no liability for any assistance with applications or customer product design. It is customer's sole responsibility to determine whether the NXP Semiconductors product is suitable and fit for the customer's applications and products planned, as well as for the planned application and use of customer's third party customer(s). Customers should provide appropriate design and operating safeguards to minimize the risks associated with their applications and products.

NXP Semiconductors does not accept any liability related to any default, damage, costs or problem which is based on any weakness or default in the customer's applications or products, or the application or use by customer's third party customer(s). Customer is responsible for doing all necessary testing for the customer's applications and products using NXP Semiconductors products in order to avoid a default of the applications and the products or of the application or use by customer's third party customer(s). NXP does not accept any liability in this respect.

Limiting values — Stress above one or more limiting values (as defined in the Absolute Maximum Ratings System of IEC 60134) will cause permanent damage to the device. Limiting values are stress ratings only and (proper) operation of the device at these or any other conditions above those given in the Recommended operating conditions section (if present) or the Characteristics sections of this document is not warranted. Constant or repeated exposure to limiting values will permanently and irreversibly affect the quality and reliability of the device.

Terms and conditions of commercial sale — NXP Semiconductors products are sold subject to the general terms and conditions of commercial sale, as published at <http://www.nxp.com/profile/terms>, unless otherwise agreed in a valid written individual agreement. In case an individual agreement is concluded only the terms and conditions of the respective agreement shall apply. NXP Semiconductors hereby expressly objects to applying the customer's general terms and conditions with regard to the purchase of NXP Semiconductors products by customer.

No offer to sell or license — Nothing in this document may be interpreted or construed as an offer to sell products that is open for acceptance or the grant, conveyance or implication of any license under any copyrights, patents or other industrial or intellectual property rights.

Export control — This document as well as the item(s) described herein may be subject to export control regulations. Export might require a prior authorization from competent authorities.

Quick reference data — The Quick reference data is an extract of the product data given in the Limiting values and Characteristics sections of this document, and as such is not complete, exhaustive or legally binding.

Non-automotive qualified products — Unless this data sheet expressly states that this specific NXP Semiconductors product is automotive qualified, the product is not suitable for automotive use. It is neither qualified nor tested in accordance with automotive testing or application requirements. NXP Semiconductors accepts no liability for inclusion and/or use of non-automotive qualified products in automotive equipment or applications.

In the event that customer uses the product for design-in and use in automotive applications to automotive specifications and standards, customer (a) shall use the product without NXP Semiconductors' warranty of the product for such automotive applications, use and specifications, and (b)

whenever customer uses the product for automotive applications beyond NXP Semiconductors' specifications such use shall be solely at customer's own risk, and (c) customer fully indemnifies NXP Semiconductors for any liability, damages or failed product claims resulting from customer design and use of the product for automotive applications beyond NXP Semiconductors' standard warranty and NXP Semiconductors' product specifications.

Translations — A non-English (translated) version of a document is for reference only. The English version shall prevail in case of any discrepancy between the translated and English versions.

16.4 Trademarks

Notice: All referenced brands, product names, service names and trademarks are the property of their respective owners.

GreenChip — is a trademark of NXP Semiconductors N.V.

17. Contact information

For more information, please visit: <http://www.nxp.com>

For sales office addresses, please send an email to: salesaddresses@nxp.com

18. Contents

1 General description 1

2 Features and benefits 1

3 Applications 2

4 Quick reference data 2

5 Ordering information 2

6 Block diagram 3

7 Pinning information 3

7.1 Pinning 3

7.2 Pin description 4

8 Functional description 4

8.1 Converter operation 4

8.2 On-time control 4

8.3 Valley detection 5

8.4 Start-up current 6

8.5 Leading-Edge Blanking (LEB) 6

8.6 Magnetization switching 6

8.7 Protections 6

8.7.1 UnderVoltage LockOut (UVLO) 7

8.7.2 Cycle-by-cycle OverCurrent Protection (OCP) 7

8.7.3 OverTemperature Protection (OTP) 7

8.7.4 Cycle-by-cycle maximum on-time protection 7

8.7.5 Output OverVoltage Protection (OVP) 7

8.7.6 Output Short Protection (OSP) 7

8.8 Supply management 8

9 Limiting values 9

10 Thermal characteristics 9

11 Characteristics 10

12 Application information 12

13 Package outline 13

14 Abbreviations 14

15 Revision history 15

16 Legal information 16

16.1 Data sheet status 16

16.2 Definitions 16

16.3 Disclaimers 16

16.4 Trademarks 17

17 Contact information 17

18 Contents 18

Please be aware that important notices concerning this document and the product(s) described herein, have been included in section 'Legal information'.



© NXP Semiconductors N.V. 2015. All rights reserved.

For more information, please visit: <http://www.nxp.com>
 For sales office addresses, please send an email to: salesaddresses@nxp.com

Date of release: 11 March 2015
 Document identifier: SSL5031CTS

Looking for pricing, stock, or lifecycle information?

Click below to explore more details on WIN SOURCE:

-  [View SSL5031CTS/1X on WIN SOURCE](#)
-  [NXP / Nexperia Information](#)

Optimize Your Supply Chain with WIN SOURCE Solutions

-  Global Sourcing Solution
-  Obsolete Management
-  Cost Control Management
-  Shortage Management
-  Alternative Solution
-  Excess Inventory Management