



**THE DATASHEET OF
TLE9201SGAUMA1**



TLE9201SG

6 A H-Bridge with SPI

Data Sheet

Rev. 1.0, 2014-02-25

Automotive Power

Table of Contents

1	Overview	3
2	Pin Configuration	4
2.1	Pin Assignment	4
2.2	Pin Definitions and Functions	4
2.3	Terms	5
3	Block Diagram	6
4	Block Description	7
4.1	Power Supply	7
4.2	Sleep Mode	7
4.3	Output Stages	8
4.4	Protection and Diagnostics	9
4.5	Current Limitation	9
4.6	Short Circuit Detection	10
4.7	Short Circuit to Battery	10
4.8	Short Circuit over Load	10
4.9	Overtemperature	10
4.10	Undervoltage Shut-Down	11
4.11	Open Load Detection	11
4.12	Serial Peripheral Interface (SPI)	12
5	General Product Characteristics	17
5.1	Absolute Maximum Ratings	17
5.2	Functional Range	18
5.3	Thermal Resistance	18
6	Electrical Characteristics	19
7	Application Information	22
8	Package Outlines	25



1 Overview

Features

- R_{DSon} of 100 m Ω per switch typ. at $T_j=25\text{ }^\circ\text{C}$
- Logic inputs 3.3 V and 5.0 V TTL/CMOS-compatible
- Low standby current
- Chopper current limitation
- Short circuit shut down with latch behavior
- Overtemperature shut down with latch behavior
- VS undervoltage shutdown
- Open load detection in ON and OFF state
- Detailed SPI diagnosis or simple error flag
- Green product (RoHS compliant)
- AEC qualified

Description

The TLE9201SG is a general purpose 6 A H-Bridge, designed for (but not limited to) the control of DC motors or other inductive loads in automotive applications. The outputs can be pulse width modulated at frequencies up to 20kHz. PWM/DIR control reduces the number of PWM capable pins needed on the microcontroller side.

For load currents above the current limitation threshold (8A typ.) the H-Bridge goes into chopper current limitation mode. It is protected against short circuits and overtemperature and provides extensive diagnosis via SPI or basic error feedback via error flag. Open load can be detected when the bridge is disabled or during PWM operation of inductive loads.

The robust PG-DSO-12-17 package provides excellent thermal capabilities due to the thick copper heat slug. Thanks to the protruding edges of the heatslug the package is well suited for automatic optical solder inspection.

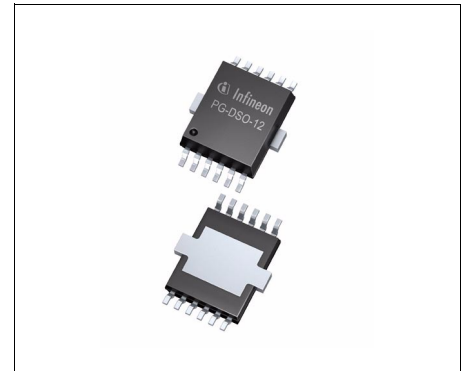

PG-DSO-12-17

Type	Package	Marking
TLE9201SG	PG-DSO-12-17	TLE9201SG

2 Pin Configuration

2.1 Pin Assignment

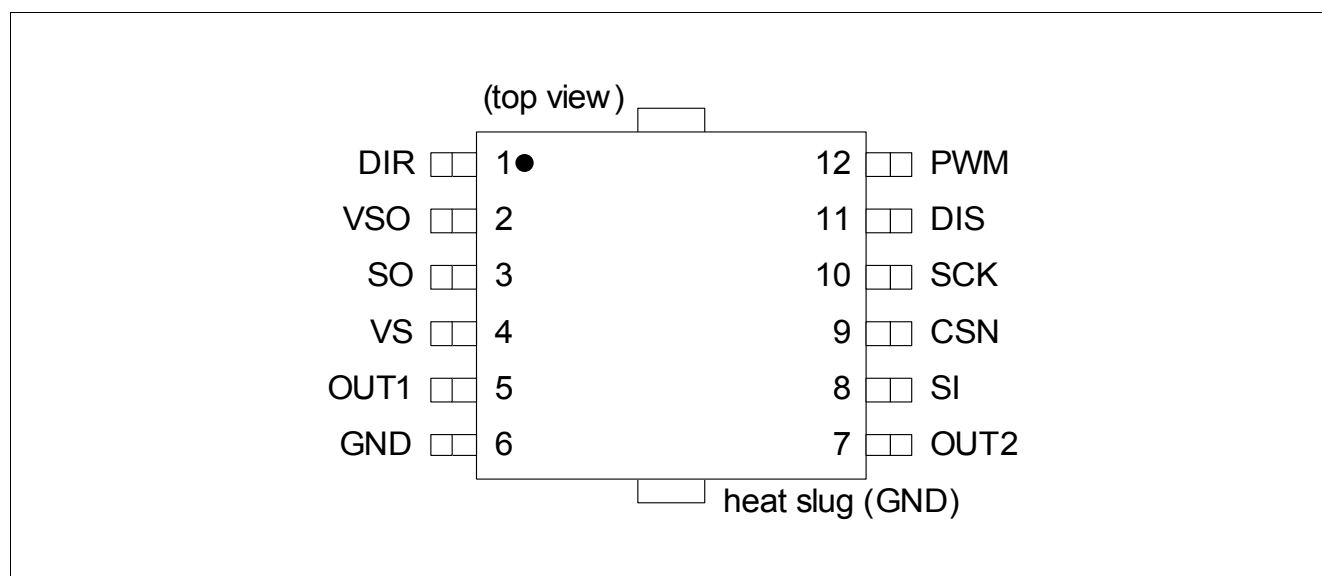

Figure 1 Pin Assignment TLE9201SG

2.2 Pin Definitions and Functions

Pin	Symbol	Function
1	DIR	Direction input to define direction of the motor current
2	VSO	Supply pin for SO output. Connect to 5V or 3.3V depending on desired logic level
3	SO	SPI serial output
4	VS	Supply voltage
5	OUT1	Output 1
6	GND	Ground
7	OUT2	Output 2
8	SI	SPI serial input
9	CSN	SPI chip select (low active)
10	SCK	SPI clock input
11	DIS	Disable. Disables the outputs (all MOSFETS off)
12	PWM	Pulse width modulation input

2.3 Terms

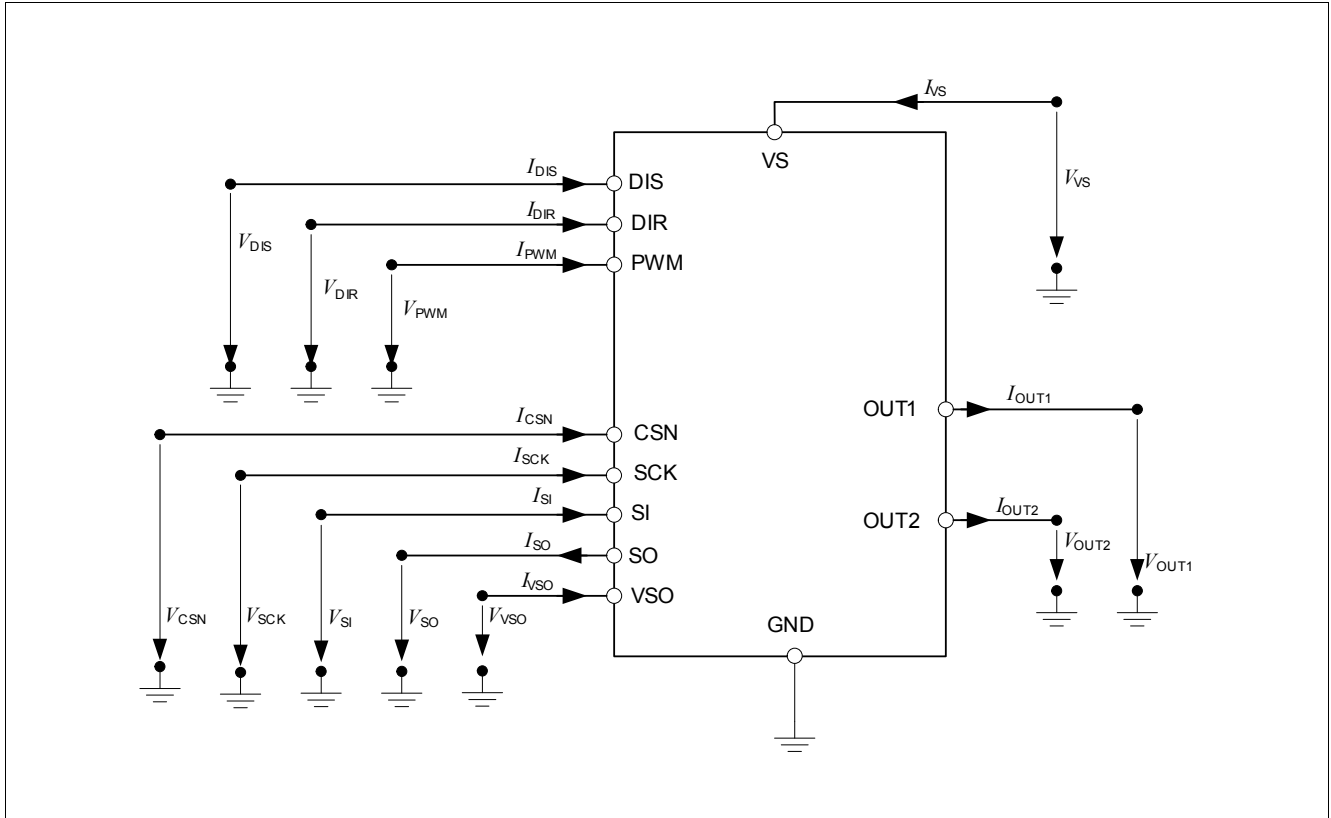

Figure 2 Terms TLE9201SG

3 Block Diagram

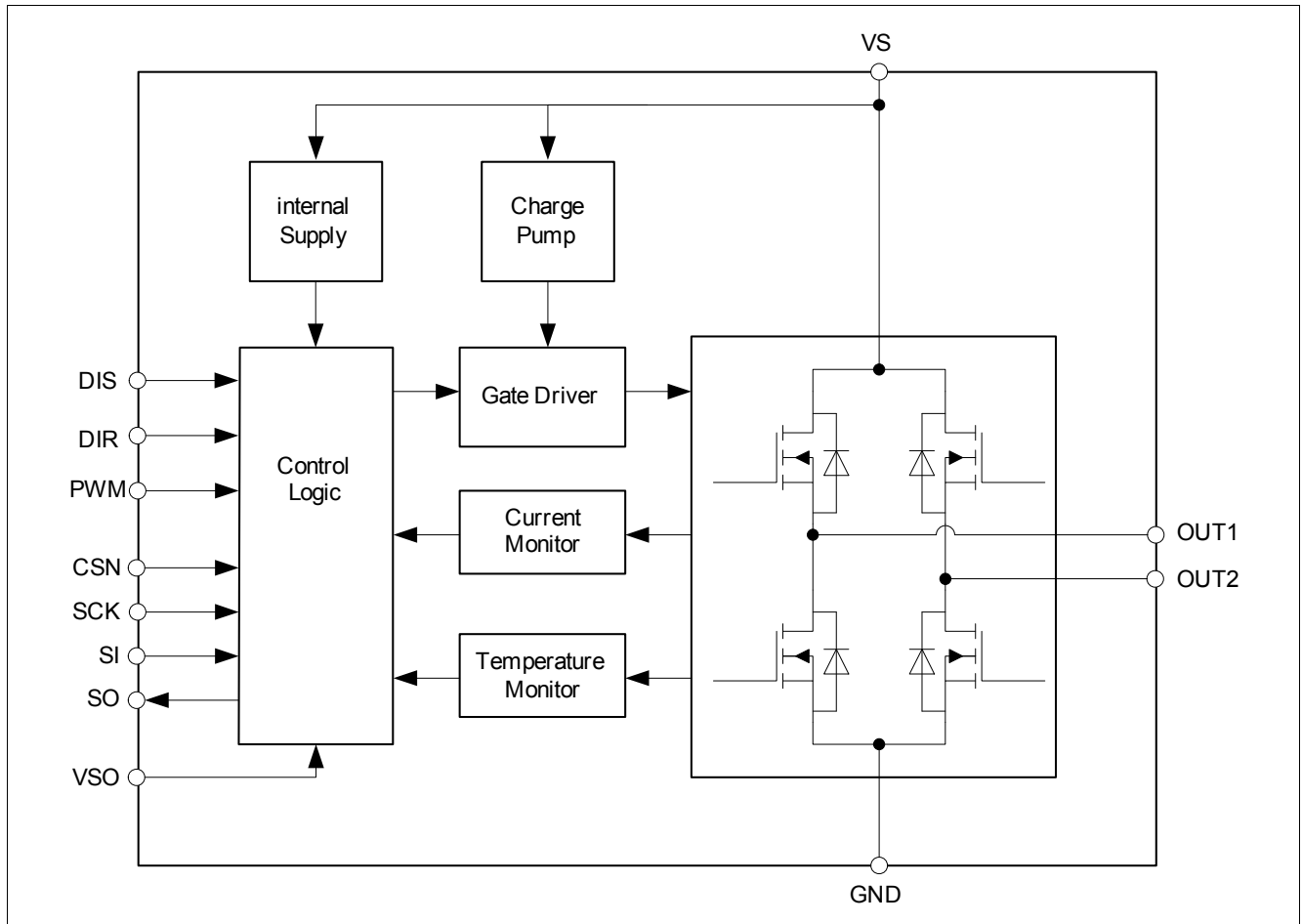

Figure 3 Block Diagram

4 Block Description

4.1 Power Supply

All internal supply voltages are derived from the pin VS. A charge pump provides the gate voltage for the high side switches. The charge pump does not require an external capacitor.

The output buffer of the digital output SO is supplied by the pin VSO. Therefore the output level at SO can be easily configured for 3.3 V or 5 V logic by connecting VSO to the respective voltage.

4.2 Sleep Mode

In order to minimize current consumption during inactive phases the device can be put into sleep mode by pulling the VSO pin to GND. This functionality can also be used to provide a second switch off path for the outputs similar to an enable pin, simply by driving VSO directly from a microcontroller output.

Since VSO is supplying also the output buffer of the SO signal it has to be ensured that the microcontroller output can provide sufficient current. Alternatively an external mosfet or a driver stage could be used to switch the VSO supply voltage. To account for dynamic switching currents it might be advisable to buffer VSO with a small capacitor (see [Figure 7 “Application Example VSO as Enable Input” on Page 24](#)).

Please note that the push pull stage of the SO output provides a current return path to VSO via the bulk diode of the highside mosfet. Therefore it has to be ensured that the voltage at SO never exceeds the voltage at VSO by more than 0.3V.

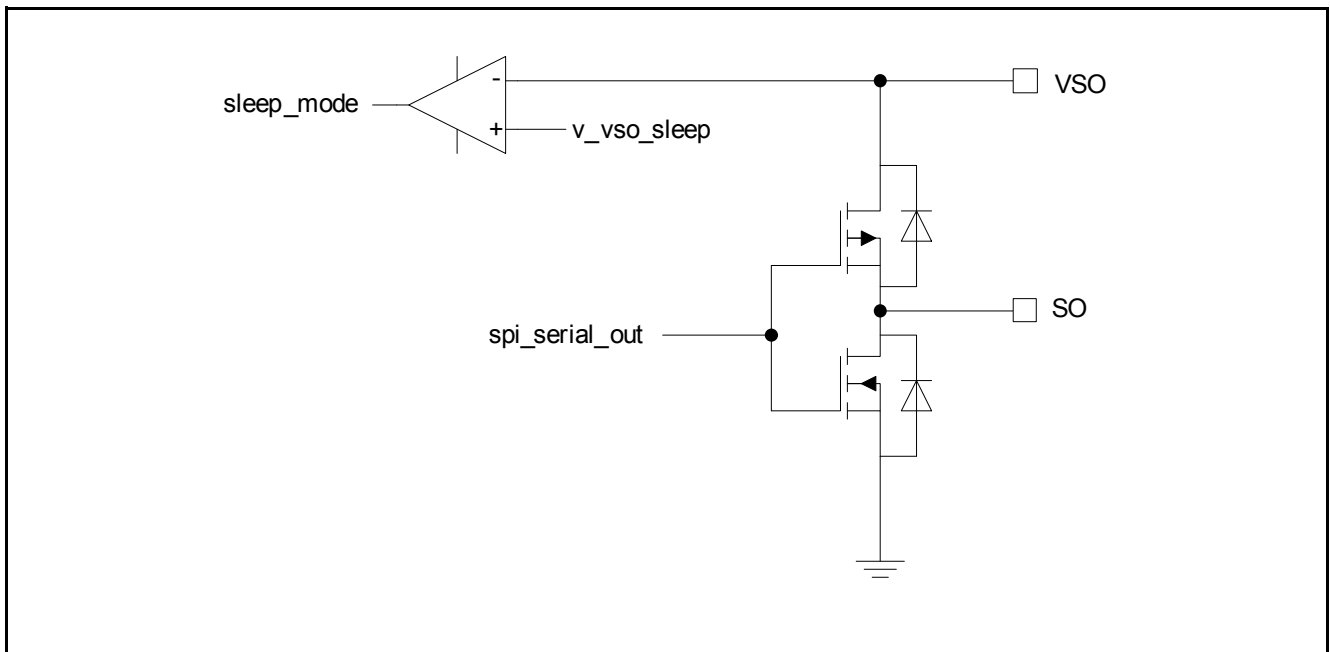

Figure 4-1 SO output buffer

4.3 Output Stages

The output stages consist of four n-channel mosfets in H-bridge configuration. The outputs are protected against short circuits and over temperature.

The bridge is controlled using the inputs PWM and DIR. The signal at DIR is defining the direction of the driven DC motor whereas the PWM signal sets the duty cycle.

The outputs can be set tristate (i.e. high side and low side switches are turned off) by setting DIS to high level.

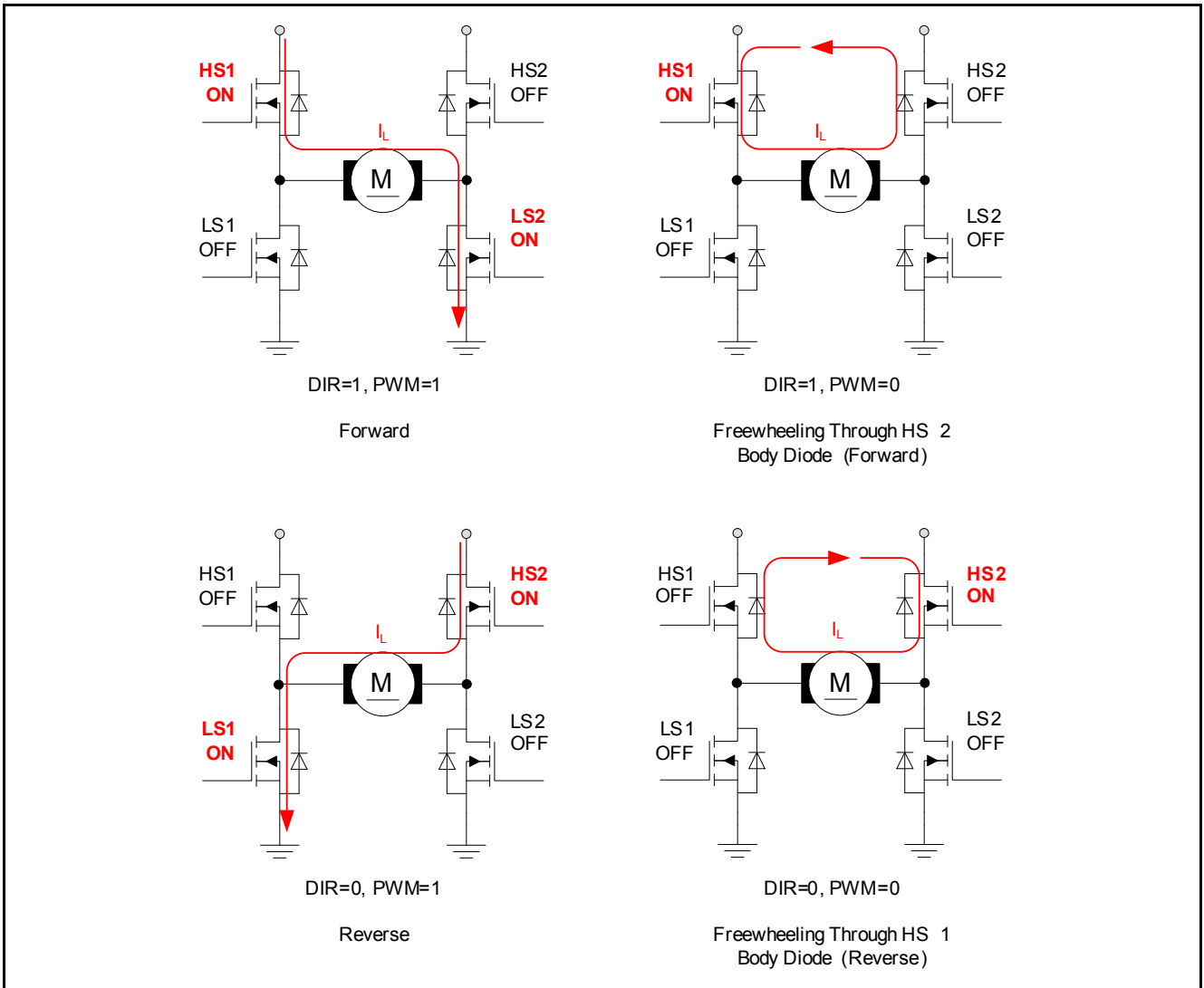

Figure 4-2 Operation Modes

Table 4-1 Output Truth Table

DIS	PWM	DIR	OUT1	OUT2	Comment
1	X	X	Z	Z	disabled, outputs tristate
0	1	1	H	L	forward / clockwise
0	1	0	L	H	reverse / counterclockwise
0	0	1	H	Z	freewheeling in HS (forward)
0	0	0	Z	H	freewheeling in HS (reverse)

4.4 Protection and Diagnostics

Both output stages of the TLE9201SG are equipped with fault diagnostic functions:

- Short to battery voltage (SCB)
- Short to ground (SCG)
- Open load (OL)
- Over-temperature (OT)

4.5 Current Limitation

To limit the output current a chopper current limitation is integrated. Current measurement for current limitation is done in the high side path.

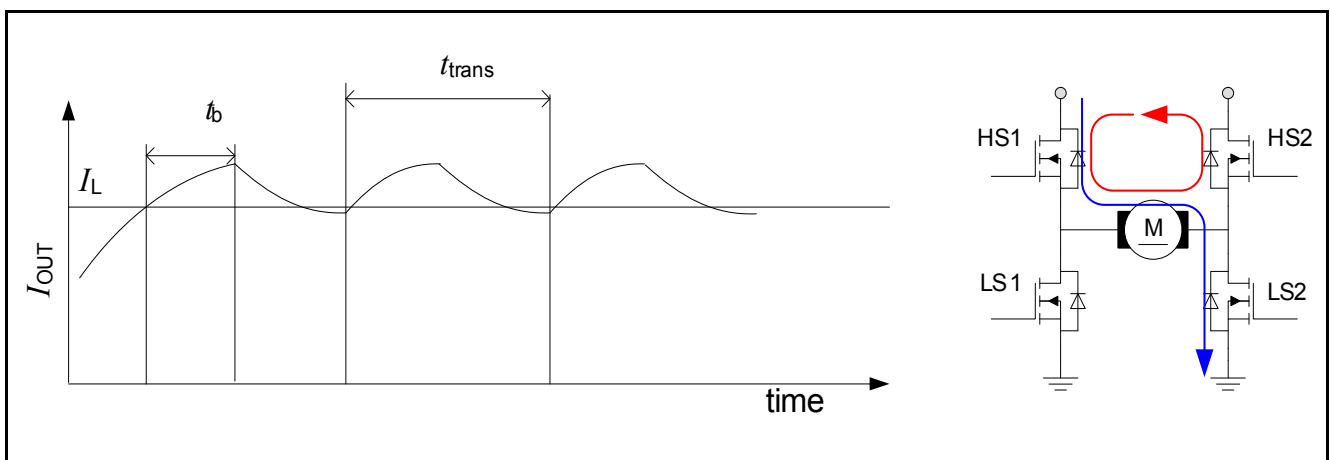

Figure 4-3 Chopper Current Limitation

Figure 4-3 shows the behavior of the current limitation for over current detection in HS1. It applies accordingly also for HS2.

When the current in high-side switch of OUT1 (HS1) exceeds the limit I_L longer than the blanking time t_b , the low side switch of OUT2 (LS2) is switched off, independent of the input signal at PWM. This leads to freewheeling through the bulk diode of HS2 and therefore to a decrease of the load current. As soon as the current falls below I_L , OUT2 is switched back to normal operation, i.e. the outputs follow the inputs according to the truth table. To avoid high switching frequencies in case of low inductive loads the minimum time between two transitions is limited to t_{trans} .

4.6 Short Circuit Detection

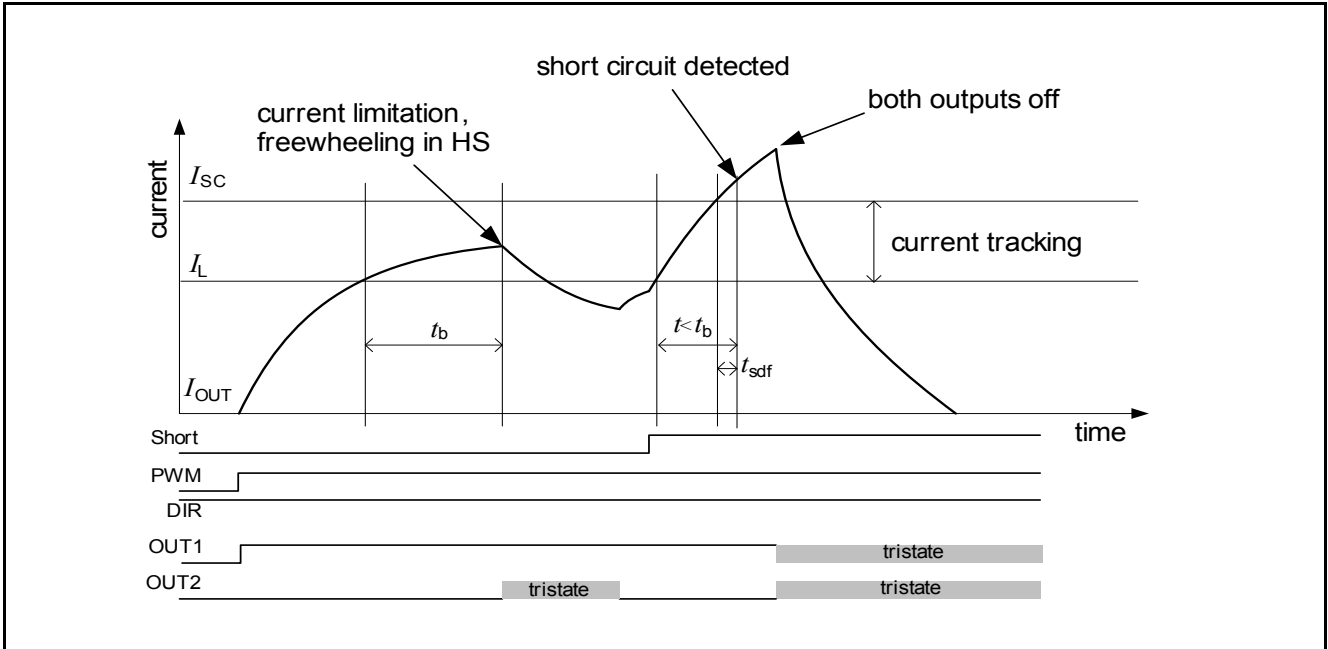

Figure 4-4 Short to Ground Detection

The short circuit to ground detection is activated when the current through one of the high side switches rises over the threshold I_{SC} and remains higher than I_{SC} for at least the filter time t_{sdf} within the blanking time t_b . Both outputs will be switched off and the failure will be reported in the SPI diagnosis register. The outputs can be re-activated by disabling and enabling the bridge via the disable signal DIS, pulling VSO to GND or by a reset command via SPI.

4.7 Short Circuit to Battery

A short circuit to battery is detected in the same way as a short circuit to ground, only in the low side switch instead of the high side switch.

4.8 Short Circuit over Load

Short circuit over load will trigger the short circuit detection either of the high side or the low side switch (whichever is faster).

4.9 Overtemperature

In case of high DC-currents, insufficient cooling or high ambient temperature, the chip temperature may rise above the thermal shut-down temperature T_{jSD} . In that case, all output transistors are turned off. Overtemperature shutdown is latching.

The outputs can be re-activated as soon as the junction temperature has fallen below the switch-on temperature T_{jSO} .

4.10 Undervoltage Shut-Down

If the supply voltage at the VS pins falls below the undervoltage detection threshold V_{UV_OFF} , the outputs are turned off. The undervoltage detection is not latching. That means that as soon as V_S rises above V_{UV_ON} again, the device is returning to normal operation.

4.11 Open Load Detection

4.11.1 Open Load Detection in OFF state

When the bridge is disabled (DIS=high) the open load in OFF detection becomes active. Two diagnostic current sources will then be connected to the outputs, a pull up current source at OUT1 and a pull down current source at OUT2. The pull down current source is stronger than the pull up current source and therefore will pull down OUT1 if a load is present. If no load is present OUT1 will be pulled high by the pull up current source. This is detected by a comparator and reported in the SPI diagnosis register.

Please note that capacitors that might be placed at the outputs for EMC reasons first have to be discharged by the pull down current source at OUT2 for the open load detection to work properly.

Also, if current is flowing through the load at the time of disabling the freewheeling current will force the outputs towards supply voltage V_S . This may lead to an erroneous reporting of open load.

Therefore the first diagnostic reading after disabling should be discarded and a second reading should be taken after the load is deenergized and the output capacitors are discharged completely.

The open load detection can be disabled by setting the OLDIS bit in the CTRL_REG register. This will disconnect the diagnostic current sources and suppress the reporting of open load in the DIA_REG register.

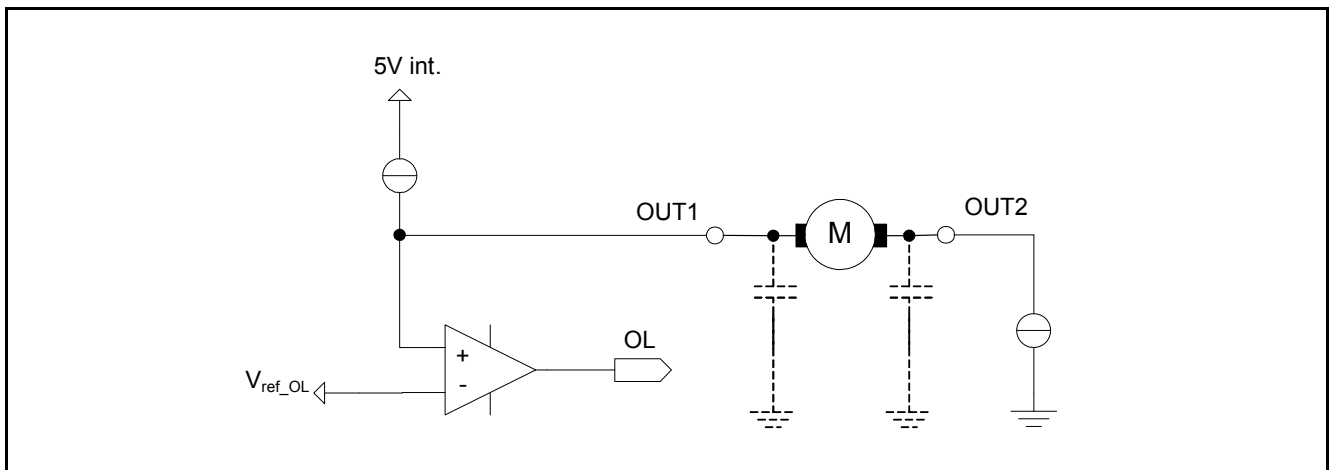

Figure 4-5 Open Load Detection in OFF state

4.11.2 Open Load Detection in ON state

The TLE9201SG contains an open load diagnosis during operation for inductive loads. It evaluates whether freewheeling occurs in the switching phase. In order to avoid inadvertent triggering of the open load diagnosis a failure counter is implemented. There have to be at least 5 occurrences of the internal open load signal (i.e. 5 PWM pulses without freewheeling detected) before open load is reported in the SPI diagnosis register.

Depending on the operation conditions and on external circuitry like the output capacitors it is possible that open load is indicated although the load is present. This might be the case for example during a direction change or for small load currents respectively small PWM duty cycles. Therefore it is recommended to evaluate the open load diagnosis only in known suitable operating conditions and to ignore it otherwise.

The open load diagnosis is not latching.

4.12 Serial Peripheral Interface (SPI)

For diagnosis purposes the TLE9201SG is equipped with a “Serial Peripheral Interface“ (SPI).

The SPI of several TLE9201SGs can be connected in daisy chain configuration in order to save microcontroller interface pins.

The TLE9201SG is configured as a “slave” device. This means that the μ C as the master is providing the chip select (CSN) and clock signal (SCK).

A data transfer on the SPI bus is initiated with a falling edge on CSN and is terminated by a rising edge on CSN. The data on the serial input pin SI is sampled with the falling edge of SCK, the serial data output at SO is determined by the rising clock edge. The data is transferred “MSB first”.

The word length of the SPI is 8 bit. Please note that there is no check for the number of clocks within a SPI frame. Any low pulse at CSN will be regarded as one frame.

4.12.1 Error Flag

Between the falling edge of CSN and the first rising edge of SCK an additional error flag signal is set asynchronously at the SO pin. The error flag signal set to high whenever the output stages are shut down (tristate) due to a failure or due to disabling of the output stages. Additionally the EF signal is OR’ed with the SI input signal. By connecting the SO of one device to the SI of the next device the EF signal can be routed through similar to a SPI daisy chain configuration.

This flag can be used for simple error feedback without SPI communication by connecting SCK and CSN to GND permanently (see [Figure 5 “Application Example H-Bridge with Error Flag” on Page 22](#)).

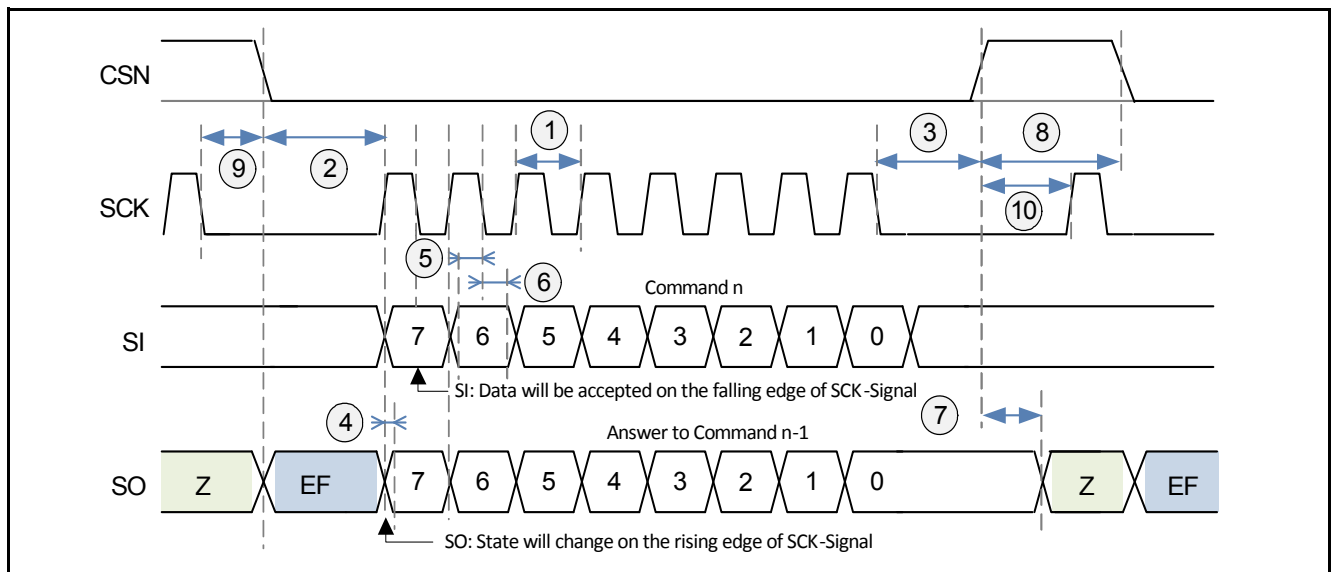

Figure 4-6 SPI Timing Definition (drawing not to scale)

4.12.2 SPI Register Description

The TLE9201SG provides detailed diagnosis and the option to control the outputs via SPI. Following commands are available (x=don't care, d=data):

Table 4-2 SPI Command Set

Command	Input Byte	Description
RD_DIA	000x xxxx	Read Diagnosis Register
RES_DIA	100x xxxx	Reset Diagnosis Register
RD_REV	001x xxxx	Read Device Revision Number
RD_CTRL	011x xxxx	Read Control Register
WR_CTRL	111d dddd	Write Control - sets and returns Control Register values
WR_CTRL_RD_DIA	110d dddd	Write Control and Read Diagnosis- sets Control Register values and returns Diagnosis Register values

The first SPI response provided after power up is the device revision number (RD_REV). For any unspecified commands the device will respond with the content of the diagnosis register (RD_DIA).

4.12.2.2 Diagnosis Register

Diagnosis Register

DIA_REG		Offset		Reset Value			
Diagnosis Register		00 _H		DF _H			
7	6	5	4	3	2	1	0
EN	OT	TV	CL	DIA4	DIA3	DIA2	DIA1
r	r	r	r	r	r	r	r

Field	Bits	Type	Description
EN	7	r	1= outputs enabled by low signal on pin DIS 0 = outputs disabled by high signal on pin DIS
OT	6	r	0 = overtemperature shutdown
TV	5	r	Always 0 - used for transmission validation
CL	4	r	0 = current limitation active
DIA4	3	r	Diagnosis bit 4
DIA3	2	r	Diagnosis bit 3
DIA2	1	r	Diagnosis bit 2
DIA1	0	r	Diagnosis bit 1

Diagnosis Truth Table

The short circuit and VS undervoltage diagnosis is coded in the DIA bits according to the following truth table. Together with transmission validation bit TV (always 0) it is ensured that there is always at least one 1->0 change at SO during a valid transmission. Therefore a “stuck at” failure of the SO pin can be detected.

Table 4-3 Encoding of Diagnosis Bits (sorted by hex value, only listed combinations are valid)

Type	DIA4	DIA3	DIA2	DIA1	Hex	Comment
No failure	1	1	1	1	0xF	-
Short to GND at OUT1 (SCG1)	1	1	1	0	0xE	latched
Short to Battery at OUT1 (SCB1)	1	1	0	1	0xD	latched
Open Load (OL)	1	1	0	0	0xC	not latched
Short to GND at OUT2 (SCG2)	1	0	1	1	0xB	latched
Short to GND at OUT1 and OUT2 (SCG1, SCG2)	1	0	1	0	0xA	latched
Short to Bat. at OUT1 and short to GND at OUT2 (SCB1, SCG2)	1	0	0	1	0x9	latched
Short to Battery at OUT2 (SCB2)	0	1	1	1	0x7	latched
Short to GND at OUT1 and short to Bat. at OUT2 (SCG1, SCB2)	0	1	1	0	0x6	latched
Short to Battery at OUT1 and OUT2 (SCB1, SCB2)	0	1	0	1	0x5	latched
VS Undervoltage (VS_UV)	0	0	1	1	0x3	not latched

Reset Behavior of Diagnosis Register

The diagnosis register is reset by the following events

Table 4-4 Diagnosis Reset Types

Name	Type	Comment
POR	Power On Reset	Reset due to power up, undervoltage or sleep mode
ENR	Enable Reset	Reset due to disabling/enabling of the outputs by DIS pin or bit SEN in CTRL_REG
SPIR	SPI Reset	Reset by sending the RES_DIA command via SPI

A change of the DIR signal will lead to a reset of current limitation (CL) or open load in on (OL) error messages. The open load in on failure will also be reset automatically if the open load condition no longer persists, i.e. freewheeling is detected for five or more consecutive pulses.

4.12.2.3 Revision Register

The Revision Register contains the device revision corresponding to the mask set.

Revision Register

REV_REG	Offset	Reset Value
Revision Register	01_H	00_H

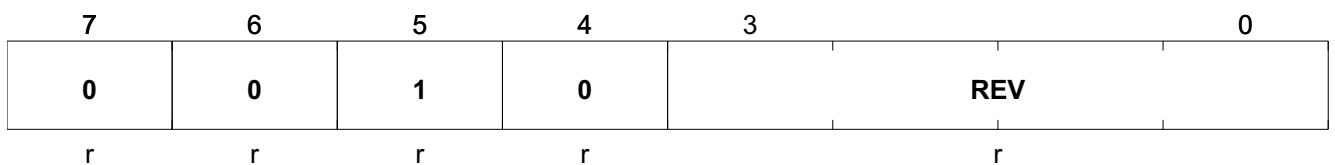

Field	Bits	Type	Description
0	7	r	fixed to 0
0	6	r	fixed to 0
1	5	r	fixed to 1
0	4	r	fixed to 0
REV	3:0	r	Device Revision corresponding to mask set

5 General Product Characteristics

5.1 Absolute Maximum Ratings

Table 1 Absolute Maximum Ratings¹⁾

$T_j = -40\text{ °C to }150\text{ °C}$

Parameter	Symbol	Values			Unit	Note / Test Condition	Number
		Min.	Typ.	Max.			
Junction temperature	T_j	-40 150	–	150 175	°C	– 100h cumulative	P_5.1.1
Storage temperature	T_s	-55	–	150	°C	–	P_5.1.2
Ambient temperature	T_a	-40	–	125	°C	–	P_5.1.3
Supply voltage	V_{VS}	-0.3	–	40	V	–	P_5.1.4
Supply for logic output	V_{VSO}	-0.3	–	5.5	V	–	P_5.1.5
Voltage at logic inputs	V_{IN}	-0.3	–	5.5	V	–	P_5.1.6
Voltage at logic output SO	V_{SO}	-0.3	–	V_{VSO} +0.3	V	both conditions must be observed	P_5.1.7
		-0.3	–	5.5			

ESD Susceptibility

ESD Susceptibility to GND acc. HBM	V_{ESD}	-2	–	2	kV	HBM ²⁾	P_5.1.8
ESD Susceptibility to GND acc. CDM	V_{ESD}	-500	–	500	V	CDM ³⁾	P_5.1.9
ESD Susceptibility to GND acc. CDM, Corner Pins	V_{ESD}	-750	–	750	V	CDM ³⁾ , Corner Pins	P_5.1.10

1) Not subject to production test, specified by design.

2) ESD susceptibility HBM according to EIA/JESD22-A114-B (1.5kΩ, 100pF)

3) ESD susceptibility, Charged Device Model "CDM" EIA/JESD22-C101

Notes

1. Stresses above the ones listed here may cause permanent damage to the device. Exposure to absolute maximum rating conditions for extended periods may affect device reliability.
2. Integrated protection functions are designed to prevent IC destruction under fault conditions described in the data sheet. Fault conditions are considered as "outside" normal operating range. Protection functions are not designed for continuous repetitive operation.

5.2 Functional Range

Table 2 Functional Range¹⁾

Parameter	Symbol	Values			Unit	Note / Test Condition	Number
		Min.	Typ.	Max.			
Supply voltage range	V_S	V_{UV_OFF}	–	28	V	–	P_5.2.1
V_S supply voltage slew rate	dV_S/dt	-10	–	10	V/ μ s	–	P_5.2.2
SO buffer supply voltage	V_{SO}	2.9	–	5.5	V	–	P_5.2.3
Junction Temperature	T_j	-40	–	150	$^{\circ}$ C	–	P_5.2.4

1) Not subject to production test, specified by design.

Note: Within the functional or operating range, the IC operates as described in the circuit description. The electrical characteristics are specified within the conditions given in the Electrical Characteristics table.

5.3 Thermal Resistance

Note: This thermal data was generated in accordance with JEDEC JESD51 standards. For more information, go to www.jedec.org.

Table 3 Thermal Resistance¹⁾

Parameter	Symbol	Values			Unit	Note / Test Condition	Number
		Min.	Typ.	Max.			
Junction to Case	R_{thJC}	–	–	2	K/W	–	P_5.3.1
Junction to Ambient	R_{thJA}	–	30	–	K/W	²⁾	P_5.3.2

1) Not subject to production test, specified by design.

2) Specified R_{thJA} value is according to Jedec JESD51-2,-5,-7 at natural convection on FR4 2s2p board; The Product (Chip+Package) was simulated on a 76.2 × 114.3 × 1.5 mm board with 2 inner copper layers (2 × 70 mm Cu, 2 × 35 mm Cu). Where applicable a thermal via array under the exposed pad contacted the first inner copper layer.

6 Electrical Characteristics

Table 4 Electrical Characteristics
 $V_S = 8\text{ V to }28\text{ V}; V_{VSO} = 2.9\text{ V to }5.5\text{ V}; T_j = -40\text{ }^\circ\text{C to }150\text{ }^\circ\text{C}$

Parameter	Symbol	Values			Unit	Note / Test Condition	Number
		Min.	Typ.	Max.			
Supply							
Supply Current	I_{VS}	–	5	13	mA	$f_{PWM} = 2\text{ kHz}; I_{OUT} = 0\text{ A}; V_{VS} = 13.5\text{ V};$	P_6.0.1
Supply Current Sleep Mode 25 °C	I_{VS}	–	19	30	µA	$V_{VS} = 13.5\text{ V}; V_{VSO} = 0\text{ V}; V_{OUTx} = 0\text{ V}; T_j = 25\text{ }^\circ\text{C}$	P_6.0.2
Supply Current Sleep Mode 150 °C ¹⁾		–	–	50	µA	$V_{VS} = 13.5\text{ V}; V_{VSO} = 0\text{ V}; V_{OUTx} = 0\text{ V}; T_j = 150\text{ }^\circ\text{C}$	P_6.0.3
VSO Sleep Mode Threshold	V_{VSO_sleep}	0.5	–	2.0	V	–	P_6.0.4
VSO Input Current, CSN high	I_{VSO}	–	–	100	µA	$I_{SO} = 0\text{ A}; V_{CSN} > 2\text{ V}$	P_6.0.5
VSO Input Current, CSN low	I_{VSO}	–	–	1.0	mA	$I_{SO} = 0\text{ A}; V_{CSN} = 0\text{ V}$	P_6.0.6
VS Undervoltage							
Undervoltage at V_S	$V_{UV\ OFF}$	3.5	4.2	5.0	V	Switch Off Threshold	P_6.0.7
Undervoltage at V_S	$V_{UV\ ON}$	3.6	4.4	5.2	V	Switch On Threshold	P_6.0.8
Undervoltage at V_S	$V_{UV\ HY}$	100	200	500	mV	Hysteresis	P_6.0.9
VS Undervoltage Detection Filter Time ¹⁾	t_{UV}	–	1	–	µs	–	P_6.0.10
Inputs PWM, DIR, SCK, SI							
Low level	V_{input_L}	–	–	0.8	V	–	P_6.0.11
High level	V_{input_H}	2.0	–	–	V	–	P_6.0.12
Hysteresis	V_{input_HYS}	0.1	0.3	–	V	–	P_6.0.13
Pull Down Current	I_{in_pd}	9	38	85	µA	$V_{in} = 5.5\text{ V}$	P_6.0.14
Input Capacity ¹⁾	C_{in}	–	–	15	pF	$V_{bias} = 2\text{ V}; V_{test} = 20\text{ mVpp}; f = 1\text{ MHz}$	P_6.0.15
Inputs DIS, CSN							
Low level	V_{input_L}	–	–	0.8	V	–	P_6.0.16
High level	V_{input_H}	2.0	–	–	V	–	P_6.0.17
Hysteresis	V_{input_HYS}	0.1	0.3	–	V	–	P_6.0.18
Pull Up Current	I_{in_pu}	9	38	85	µA	$V_{in} = 0\text{ V}$	P_6.0.19
Input Capacity ¹⁾	C_{in}	–	–	15	pF	$V_{bias} = 2\text{ V}; V_{test} = 20\text{ mVpp}; f = 1\text{ MHz}$	P_6.0.20

Electrical Characteristics
Table 4 Electrical Characteristics
 $V_S = 8\text{ V to }28\text{ V}; V_{VSO} = 2.9\text{ V to }5.5\text{ V}; T_j = -40\text{ }^\circ\text{C to }150\text{ }^\circ\text{C}$

Parameter	Symbol	Values			Unit	Note / Test Condition	Number
		Min.	Typ.	Max.			
Output SO							
Low level	V_{SO_L}	0.0	–	0.4	V	$I_{SO} = -1\text{ mA}$	P_6.0.21
High level	V_{SO_H}	$V_{VSO} - 0.75$	–	V_{VSO}	V	$I_{SO} = 1\text{ mA};$ $2.9\text{ V} < V_{VSO} < 5.5\text{ V}$	P_6.0.22
Tristate Leakage Current	I_{SO}	-5	–	5	μA	$0\text{V} < V_{SO} < V_{VSO};$ $V_{VSO} = 5.5\text{ V}$	P_6.0.23
Output Capacity ¹⁾	C_{SO}	–	–	19	pF	$V_{bias} = 2\text{ V};$ $V_{test} = 20\text{ mVpp};$ $f = 1\text{ MHz}$	P_6.0.24
Power Outputs OUT1, OUT2							
On resistance low side	R_{OUTL}	–	100	–	m Ω	$I_{OUT} = 2\text{ A}; T_j = 25\text{ }^\circ\text{C}$	P_6.0.25
		–	–	200	m Ω	$I_{OUT} = 2\text{ A}; T_j = 150\text{ }^\circ\text{C}$	
On resistance high side	R_{OUTH}	–	100	–	m Ω	$I_{OUT} = 2\text{ A}; T_j = 25\text{ }^\circ\text{C}$	P_6.0.26
		–	–	200	m Ω	$I_{OUT} = 2\text{ A}; T_j = 150\text{ }^\circ\text{C}$	
Leakage current	$I_{OUT1(off)}$ $I_{OUT2(off)}$	-25	–	25	μA	$V_{VS} = 13.5\text{ V};$ Outputs off; OLDIS high	P_6.0.27
		-100	–	25	μA	$V_{VS} = 13.5\text{ V};$ Sleep Mode	
Free-wheel diode forward voltage	U_D	–	0.9	1.0	V	$I_D = 2\text{ A}$	P_6.0.28
Output Switching Times ²⁾							
Rise time HS	$t_r(HS)$	5	–	40	μs	$V_{VS} = 13.5\text{ V};$ $R_{Load} = 6.8\text{ }\Omega$	P_6.0.29
Fall time HS	$t_f(HS)$	5	–	40	μs		P_6.0.30
Rise time LS	$t_r(LS)$	1.0	–	7.0	μs		P_6.0.31
Fall time LS	$t_f(LS)$	1.0	–	7.0	μs		P_6.0.32
PWM Frequency ¹⁾	f_{PWM}	0	–	20	kHz	–	P_6.0.33
Output Delay Times ²⁾							
Output on-delay HS	$t_{d_on(HS)}$	–	–	80	μs	$V_{VS} = 13.5\text{ V};$ $R_{Load} = 6.8\text{ }\Omega$	P_6.0.34
Output off-delay HS	$t_{d_off(HS)}$	–	–	80	μs		P_6.0.35
Output on-delay LS	$t_{d_on(LS)}$	–	–	10	μs		P_6.0.36
Output off-delay LS	$t_{d_off(LS)}$	–	–	10	μs		P_6.0.37
Disable delay time	t_{d_dis}	–	–	80	μs		P_6.0.38
Enable delay time	t_{d_en}	–	–	80	μs		P_6.0.39
Disable/Enable filter time ¹⁾	t_{f_en}	0.4	–	3	μs		P_6.0.40
Wake Up delay time ¹⁾	t_{wu}	–	–	1	ms	VSO high --> OUT high	P_6.0.41
Chopper Current Limitation							
Current Limit	I_L	6.0	8.0	10.0	A	$V_{VS} = 13.5\text{ V}$	P_6.0.42
Blanking time ¹⁾	t_b	5	8	13	μs	–	P_6.0.43
Minimum transition time ¹⁾	t_{trans}	–	95	–	μs	–	P_6.0.44

Table 4 Electrical Characteristics
 $V_S = 8\text{ V to }28\text{ V}; V_{VSO} = 2.9\text{ V to }5.5\text{ V}; T_j = -40\text{ }^\circ\text{C to }150\text{ }^\circ\text{C}$

Parameter	Symbol	Values			Unit	Note / Test Condition	Number
		Min.	Typ.	Max.			
Short Circuit Detection							
Short circuit detection threshold high side switch	I_{SC_H}	8.0	11.5	14.5	A	$V_{VS} = 13.5\text{ V}$	P_6.0.45
Short circuit detection threshold low side switch	I_{SC_L}	8.0	11.5	14.5	A		P_6.0.46
Current tracking high side	$I_{SC_H} - I_L$	2.0	4.0	5.2	A		P_6.0.47
Current tracking low side	$I_{SC_L} - I_L$	1.8	3.5	5.2	A		P_6.0.48
Short Circuit detection filter time ¹⁾	t_{sdf}	–	2	–	μs	–	P_6.0.49
Open Load Detection in OFF State							
Pull up Current at OUT1	I_{OUT1_OL}	60	140	200	μA	$V_{VS} = 13.5\text{ V}; V_{OUT1} = 0\text{ V}$	P_6.0.50
Pull down Current at OUT2	I_{OUT2_OL}	200	350	500	μA	$V_{VS} = V_{OUT2} = 13.5\text{ V}$	P_6.0.51
Ratio of current sources	$Ratio_I_{OL}$	1.8	2.5	3.5	–	–	P_6.0.52
Open load detection in OFF filter time ¹⁾	t_{f_OL}	40	–	–	μs	–	P_6.0.53
SPI Timing (see Figure 4-6)¹⁾							
Cycle-time (1)	t_{cyc}	490	–	–	ns	Referred to master	P_6.0.54
Enable Lead Time (2)	t_{lead}	50	–	–	ns	Referred to master	P_6.0.55
Enable Lag Time (3)	t_{lag}	150	–	–	ns	Referred to master	P_6.0.56
Data Valid (4) ³⁾	t_v	–	–	150 230	ns	$C_L = 200\text{ pF}$ $C_L = 350\text{ pF}$ Referred to TLE9201SG	P_6.0.57
Data Setup Time (5)	t_{su}	40	–	–	ns	Referred to master	P_6.0.58
Data Hold Time (6)	t_h	40	–	–	ns	Referred to master	P_6.0.59
Disable Time (7)	t_{dis}	–	–	100	ns	Referred to TLE9201SG	P_6.0.60
Transfer Delay (8)	t_{dt}	2	–	–	μs	Referred to master	P_6.0.61
Disable Lead Time (9)	t_{dld}	250	–	–	ns	Referred to master	P_6.0.62
Disable Lag Time (10)	t_{dlg}	250	–	–	ns	Referred to master	P_6.0.63
Thermal Shutdown							
Thermal Shutdown Junction Temperature ¹⁾	T_{jSD}	150	175	–	$^\circ\text{C}$	–	P_6.0.64
Thermal Switch-On Junction Temperature ¹⁾	T_{jSO}	125	–	–	$^\circ\text{C}$	–	P_6.0.65

1) Not subject to production test, specified by design.

2) Output switching times are measured between 20% and 80% of the output swing

3) V_{SO} timing thresholds are 20% / 80% of V_{VSO} for $4.5\text{ V} < V_{VSO} < 5.5\text{ V}$ and 30% / 70% of V_{VSO} for $2.9\text{ V} < V_{VSO} < 4.5\text{ V}$

7 Application Information

Note: The following information is given as a hint for the implementation of the device only and shall not be regarded as a description or warranty of a certain functionality, condition or quality of the device. The function of the described circuits must be verified in the real application

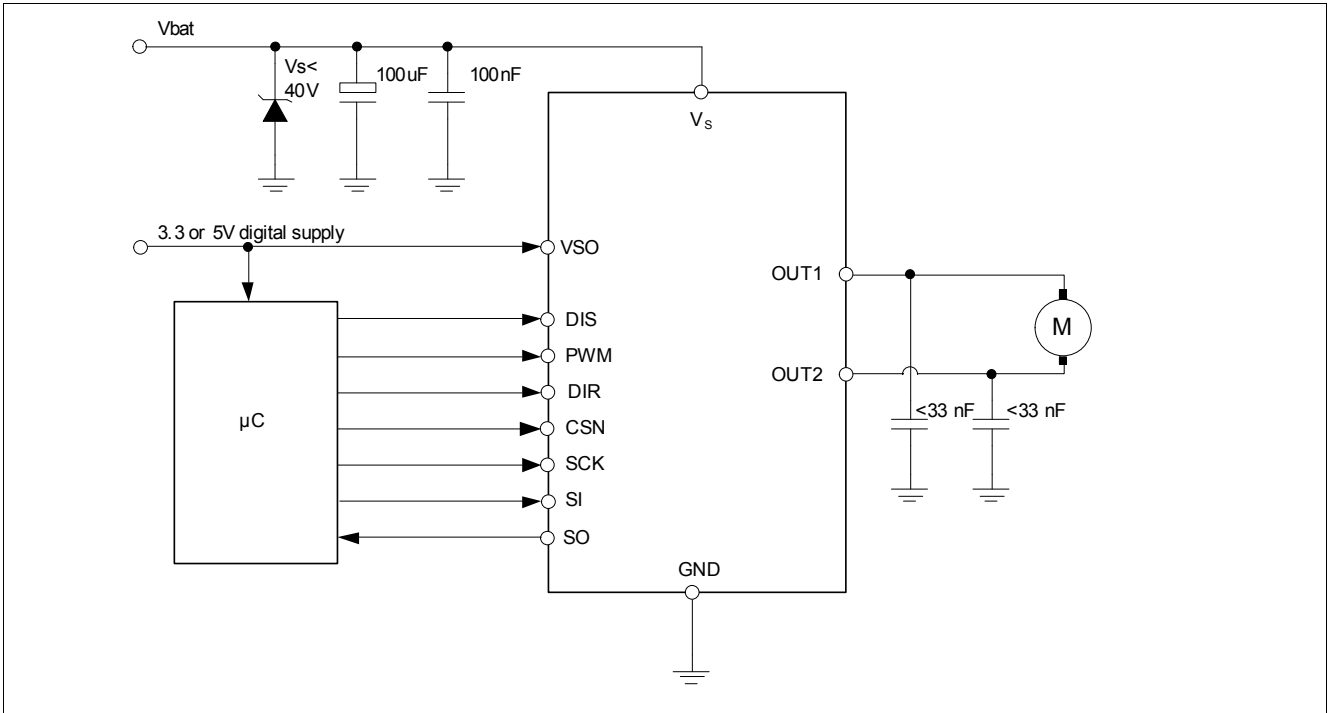

Figure 4 Application Example H-Bridge with SPI interface

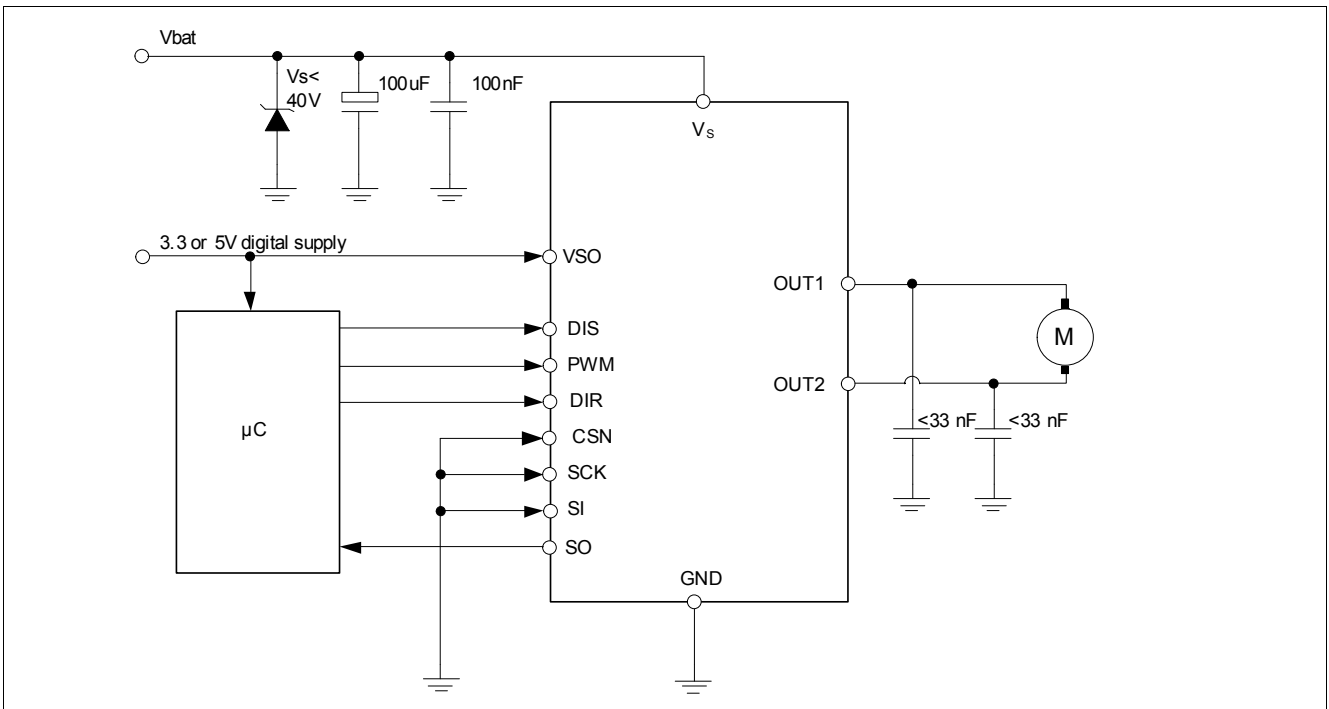

Figure 5 Application Example H-Bridge with Error Flag

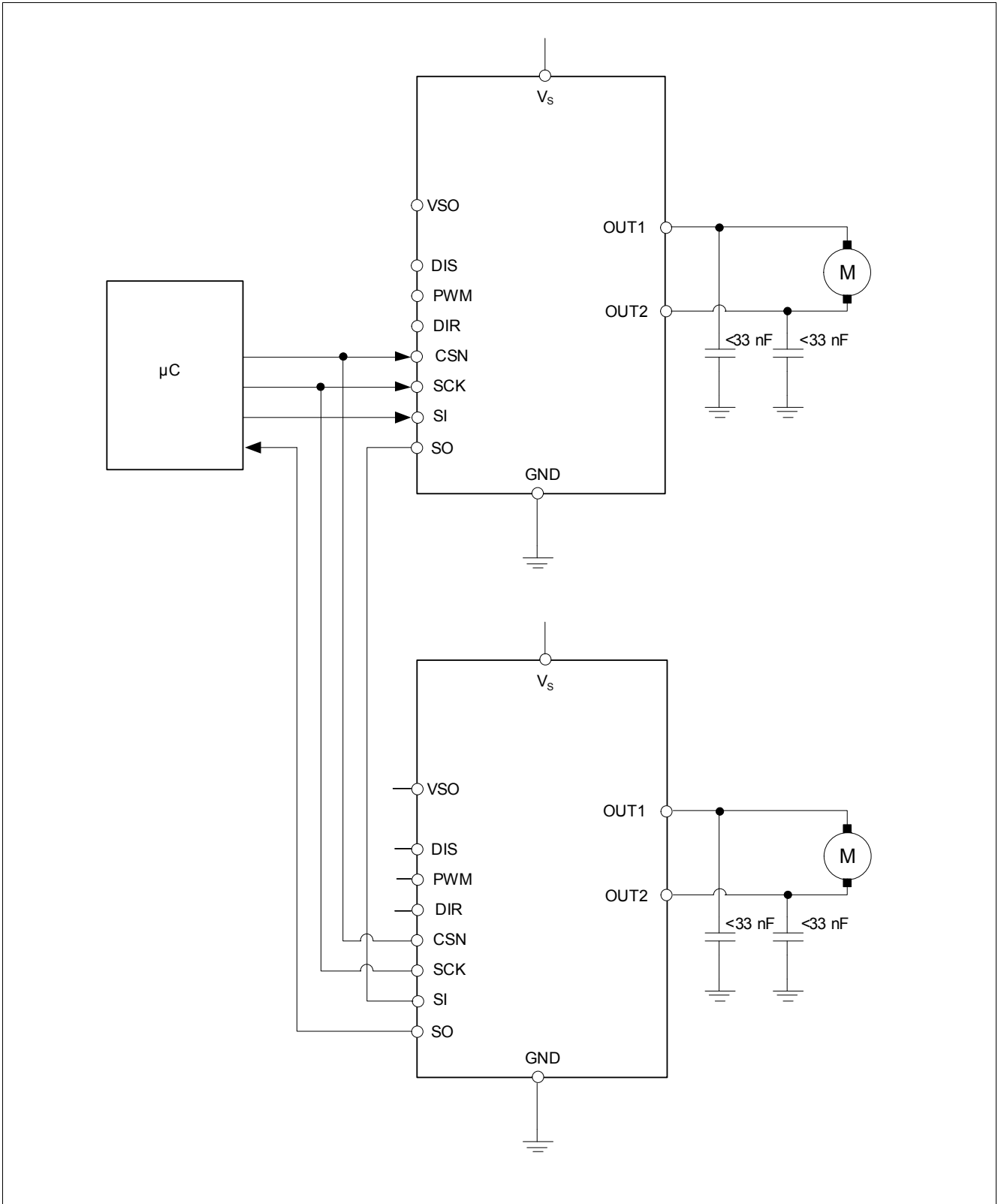

Figure 6 SPI Daisy Chain Konfiguration (other signals omitted for clarity)

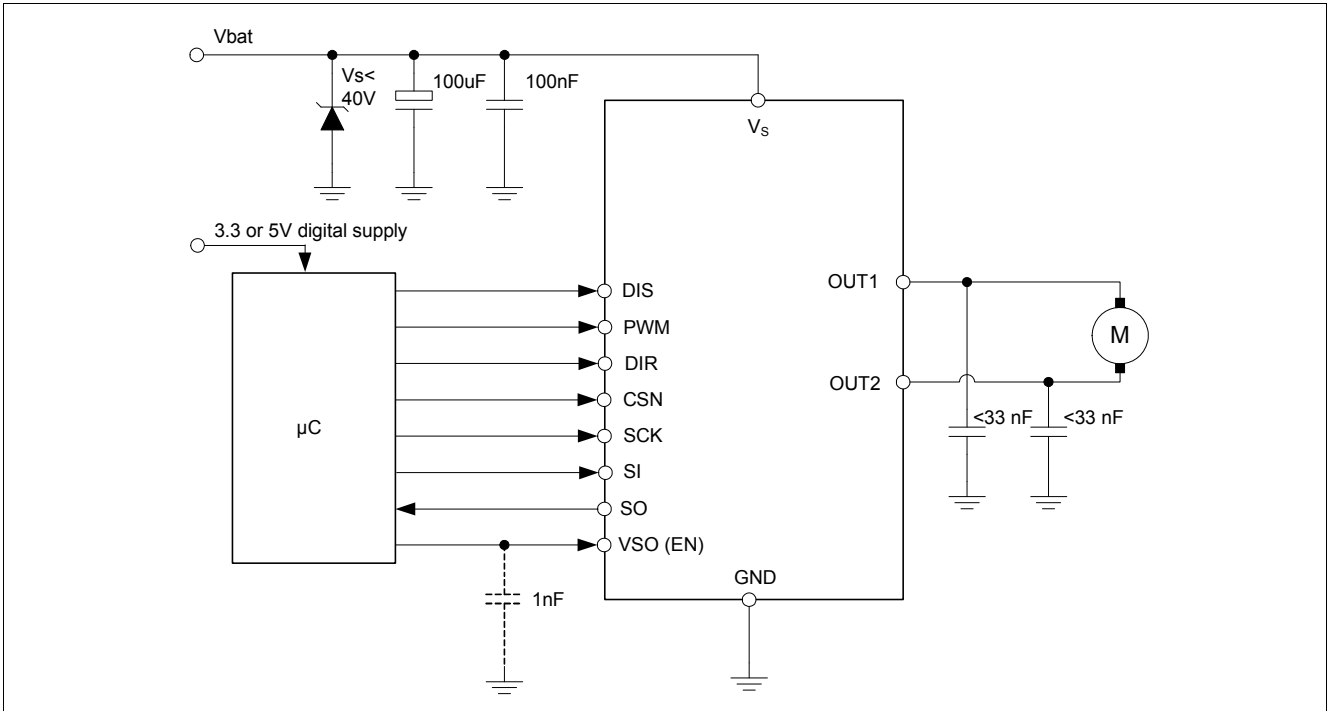

Figure 7 Application Example VSO as Enable Input

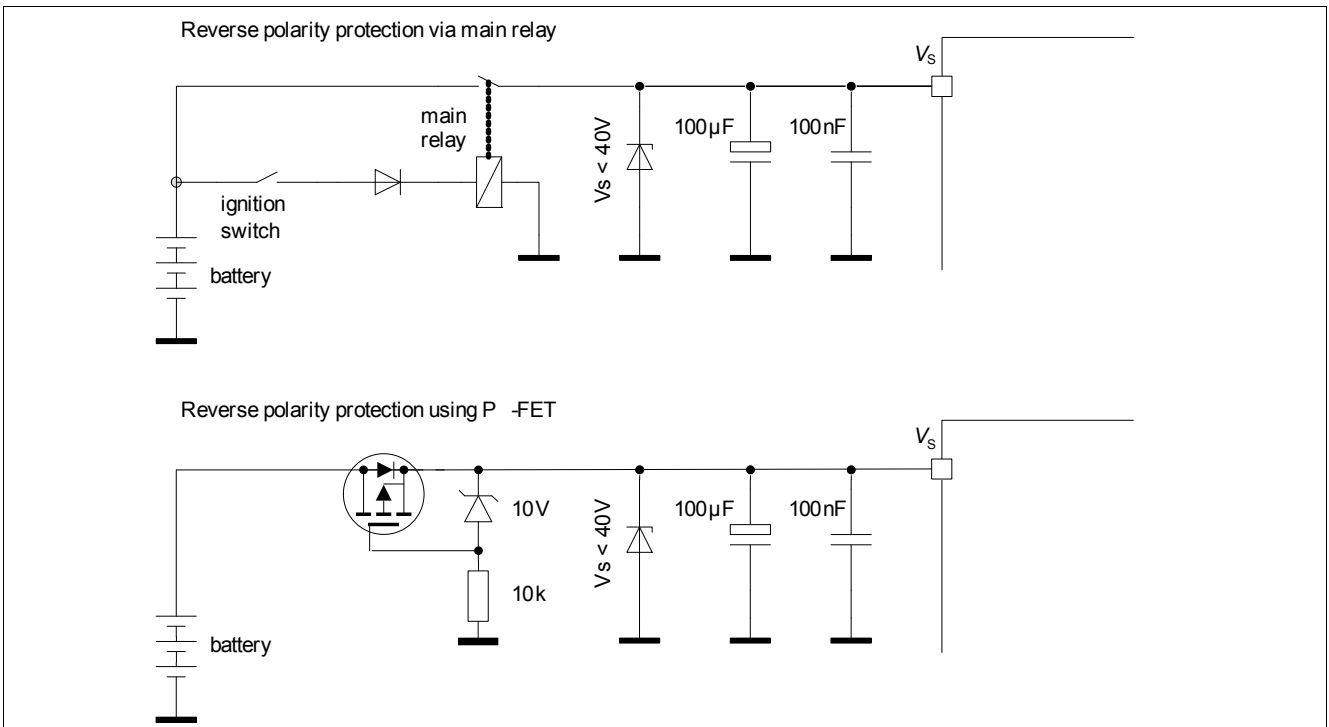

Figure 8 Examples for Reverse Polarity Protection

The TLE9201SG is not protected against reverse polarity. External measures have to be taken to ensure the right polarity of the supply voltage.

8 Package Outlines

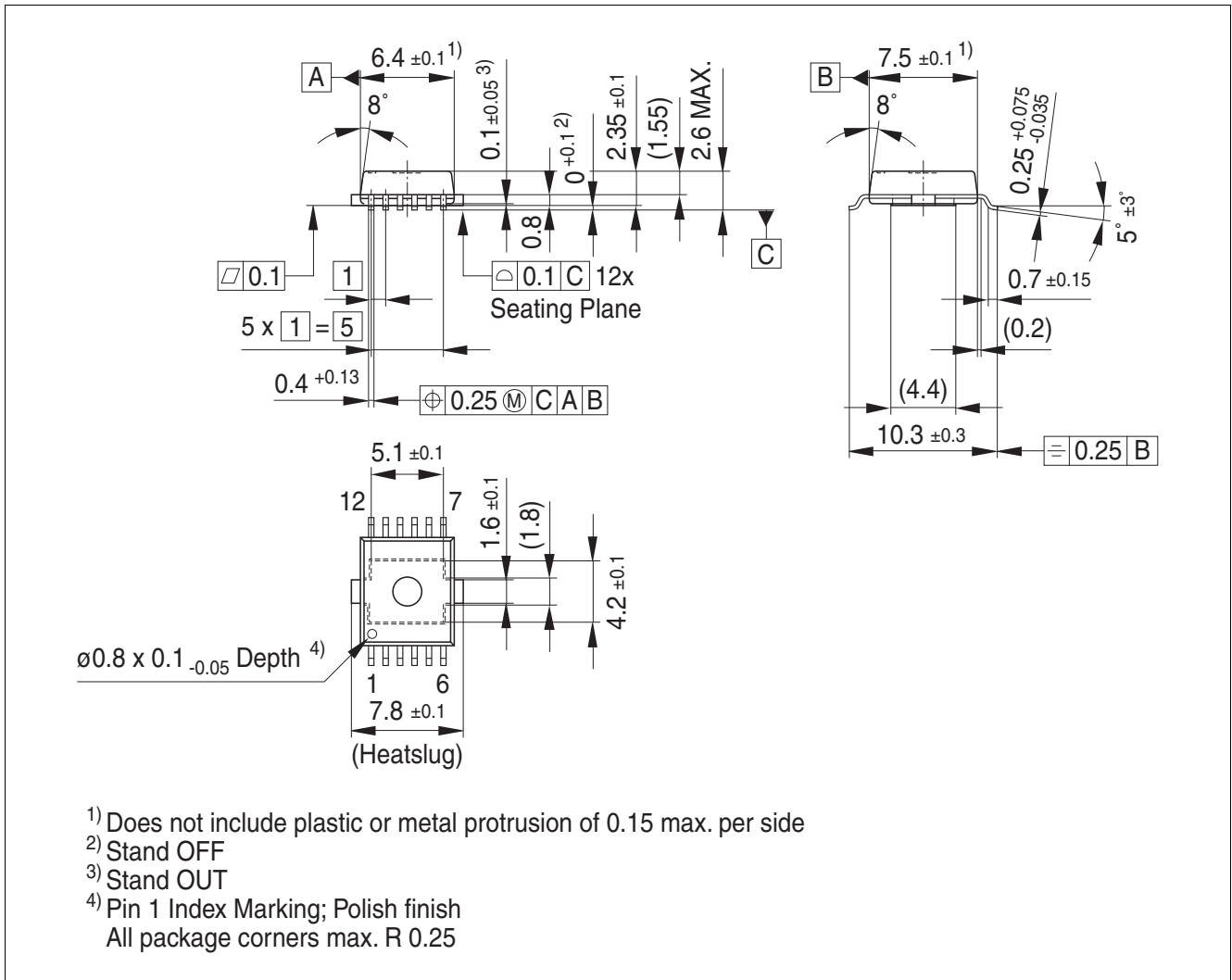

Figure 9 PG-DSO-12-17

Green Product (RoHS compliant)

To meet the world-wide customer requirements for environmentally friendly products and to be compliant with government regulations the device is available as a green product. Green products are RoHS-Compliant (i.e Pb-free finish on leads and suitable for Pb-free soldering according to IPC/JEDEC J-STD-020).

For further information on alternative packages, please visit our website:
<http://www.infineon.com/packages>.

Dimensions in mm

Edition 2014-02-25

**Published by
Infineon Technologies AG
81726 Munich, Germany**

**© 2014 Infineon Technologies AG
All Rights Reserved.**

Legal Disclaimer

The information given in this document shall in no event be regarded as a guarantee of conditions or characteristics. With respect to any examples or hints given herein, any typical values stated herein and/or any information regarding the application of the device, Infineon Technologies hereby disclaims any and all warranties and liabilities of any kind, including without limitation, warranties of non-infringement of intellectual property rights of any third party.

Information

For further information on technology, delivery terms and conditions and prices, please contact the nearest Infineon Technologies Office (www.infineon.com).

Warnings

Due to technical requirements, components may contain dangerous substances. For information on the types in question, please contact the nearest Infineon Technologies Office.

Infineon Technologies components may be used in life-support devices or systems only with the express written approval of Infineon Technologies, if a failure of such components can reasonably be expected to cause the failure of that life-support device or system or to affect the safety or effectiveness of that device or system. Life support devices or systems are intended to be implanted in the human body or to support and/or maintain and sustain and/or protect human life. If they fail, it is reasonable to assume that the health of the user or other persons may be endangered.

Looking for pricing, stock, or lifecycle information?

Click below to explore more details on WIN SOURCE:

- ⊖ [View TLE9201SGAUMA1 on WIN SOURCE](#)
- ⊖ [Infineon Technologies Information](#)

Optimize Your Supply Chain with WIN SOURCE Solutions

- ✓ Global Sourcing Solution
- ✓ Obsolete Management
- ✓ Cost Control Management
- ✓ Shortage Management
- ✓ Alternative Solution
- ✓ Excess Inventory Management