



**THE DATASHEET OF
S70GL02GP11FAIR23**



General Description

The Cypress S70GL02GP 2 Gbit Mirrorbit Flash device is fabricated on 90-nm process technology. This device offers a fast page access time of 25 ns with a corresponding random access time of 110 ns. It features a Write Buffer that allows a maximum of 32 words/64 bytes to be programmed in one operation, resulting in faster effective programming time than standard single byte/word programming algorithms. This makes the device an ideal product for today's embedded applications that require higher density, better performance and lower power consumption.

This document contains information for the S70GL02GP device, which is a dual die stack of two S29GL01GP die. For detailed specifications, refer to the discrete die datasheet provided in [Table 1](#).

Table 1. Affected Documents/Related Documents

Title	Publication Number
S29GL01GP, S29GL512P, S29GL256P, S29GL128P 1 Gbit, 512, 256, 128 Mbit, 3 V, Page Flash with 90 nm MirrorBit Process Technology	002-00886

Distinctive Characteristics

- Two 1024 Mbit (S29GL01GP) in a single 64-ball Fortified-BGA package (see [S29GL01P datasheet](#) for full specifications)
- Single 3V read/program/erase (3.0V - 3.6V)
- 90 nm MirrorBit process technology
- 8-word/16-byte page read buffer
- 32-word/64-byte write buffer reduces overall programming time for multiple-word writes
- Secured Silicon Sector region
 - 128-word/256-byte sector for permanent, secure identification through an 8-word/16-byte random Electronic Serial Number
 - Can be programmed and locked at the factory or by the customer
- Uniform 64Kword/128KByte Sector Architecture
 - S70GL02GP: two thousand forty-eight sectors
- 100,000 erase cycles per sector typical
- 20-year data retention typical
- Offered Packages
 - 64-ball Fortified BGA
- Suspend and Resume commands for Program and Erase operations
- Write operation status bits indicate program and erase operation completion
- Unlock Bypass Program command to reduce programming time
- Support for Common Flash Interface (CFI)
- Persistent and Password methods of Advanced Sector Protection
- WP#/ACC input
 - Accelerates programming time (when V_{ACC} is applied) for greater throughput during system production
 - Protects first or last sector of each die, regardless of sector protection settings
- Hardware reset input (RESET#) resets device
- Ready/Busy# output (RY/BY#) detects program or erase cycle completion

Performance Characteristics

Max. Read Access Times (ns)(Note 1)	
Parameter	2 Gb
Random Access Time (t_{ACC})	110
Page Access Time (t_{PACC})	25
CE# Access Time (t_{CE})	110
OE# Access Time (t_{OE})	25

Notes

1. Access times are dependent on V_{CC} and V_{IO} operating ranges. See [Ordering Information on page 4](#) for further details.
2. Contact a sales representative for availability.

Current Consumption (typical values)	
Random Access Read	30 mA
8-Word Page Read	1 mA
Program/Erase	50 mA
Standby	2 μ A

Program & Erase Times (typical values)	
Single Word Programming	60 μ s
Effective Write Buffer Programming (V_{CC}) Per Word	15 μ s
Effective Write Buffer Programming (V_{ACC}) Per Word	15 μ s
Sector Erase Time (64 Kword Sector)	0.5 s

Contents

1. Ordering Information	4	3. Memory Map	8
1.1 Recommended Combinations.....	4	4. Autoselect	8
2. Input/Output Description and Logic Symbol	5	5. Erase And Programming Performance	8
2.1 Special Handling Instructions for BGA Package.....	6	6. BGA Package Capacitance	9
2.2 LSE064—64 ball Fortified Ball Grid Array, 13 ´ 11 mm .	7	7. Revision History	10

1. Ordering Information

The ordering part number is formed by a valid combination of the following:

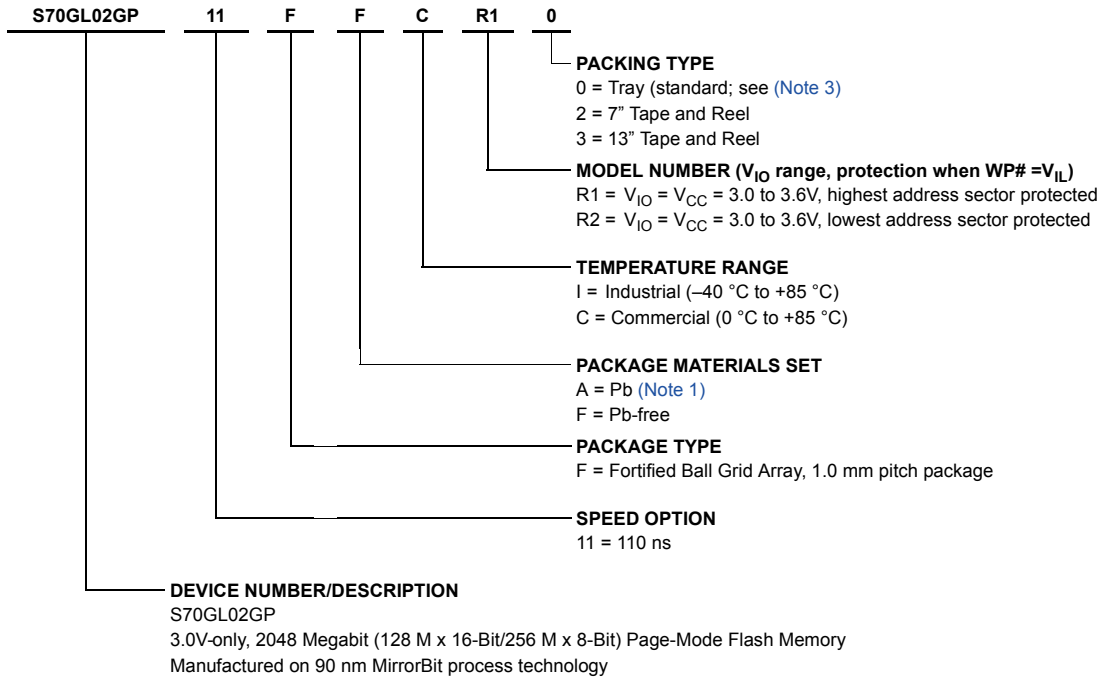

1.1 Recommended Combinations

Recommended Combinations table below list various configurations planned to be available in volume. The table below will be updated as new combinations are released. Check with your local sales representative to confirm availability of specific configuration not listed or to check on newly released combinations.

S29GL-P Recommended Combinations (Note 1)					
Base OPN	Speed (ns)	Package and Temperature	Model Number	Packing Type	Ordering Part Number (x = Packing Type)
S70GL02GP	110	FFC, FAC (Note 2)	R1, R2	0, 2, 3 (Note 3)	S70GL02GP11FFCR1x S70GL02GP11FFCR2x S70GL02GP11FACR1x S70GL02GP11FACR2x

Notes

1. Contact a local sales representative for availability.
2. BGA package marking omits leading "S29" and packing type designator from ordering part number.
3. Packing Type "0" is standard option.

2. Input/Output Description and Logic Symbol

Table 1 identifies the input and output package connections provided on the device.

Table 1. Input/Output Description

Symbol	Type	Description
A26–A0	Input	Address lines for GL02GP
DQ14–DQ0	I/O	Data input/output.
DQ15/A-1	I/O	DQ15: Data input/output in word mode. A-1: LSB address input in byte mode.
CE#	Input	Chip Enable.
OE#	Input	Output Enable.
WE#	Input	Write Enable.
V _{CC}	Supply	Device Power Supply.
V _{IO}	Supply	Versatile IO Input.
V _{SS}	Supply	Ground.
RY/BY#	Output	Ready/Busy. Indicates whether an Embedded Algorithm is in progress or complete. At V _{IL} , the device is actively erasing or programming. At High Z, the device is in ready.
BYTE#	Input	Selects data bus width. At V _{IL} , the device is in byte configuration and data I/O pins DQ0–DQ7 are active. At V _{IH} , the device is in word configuration and data I/O pins DQ0–DQ15 are active.
RESET#	Input	Hardware Reset. Low = device resets and returns to reading array data.
WP#/ACC	Input	Write Protect/Acceleration Input. At V _{IL} , disables program and erase functions in the outermost sectors. At V _{IH} , accelerates programming; automatically places device in unlock bypass mode. Should be at V _{IH} for all other conditions.
NC	No Connect	Not connected internally.

2.2 LSE064—64 ball Fortified Ball Grid Array, 13 × 11 mm

Figure 2.2 LSE064—64-ball Fortified Ball Grid Array (FBGA), 13 x 11 mm

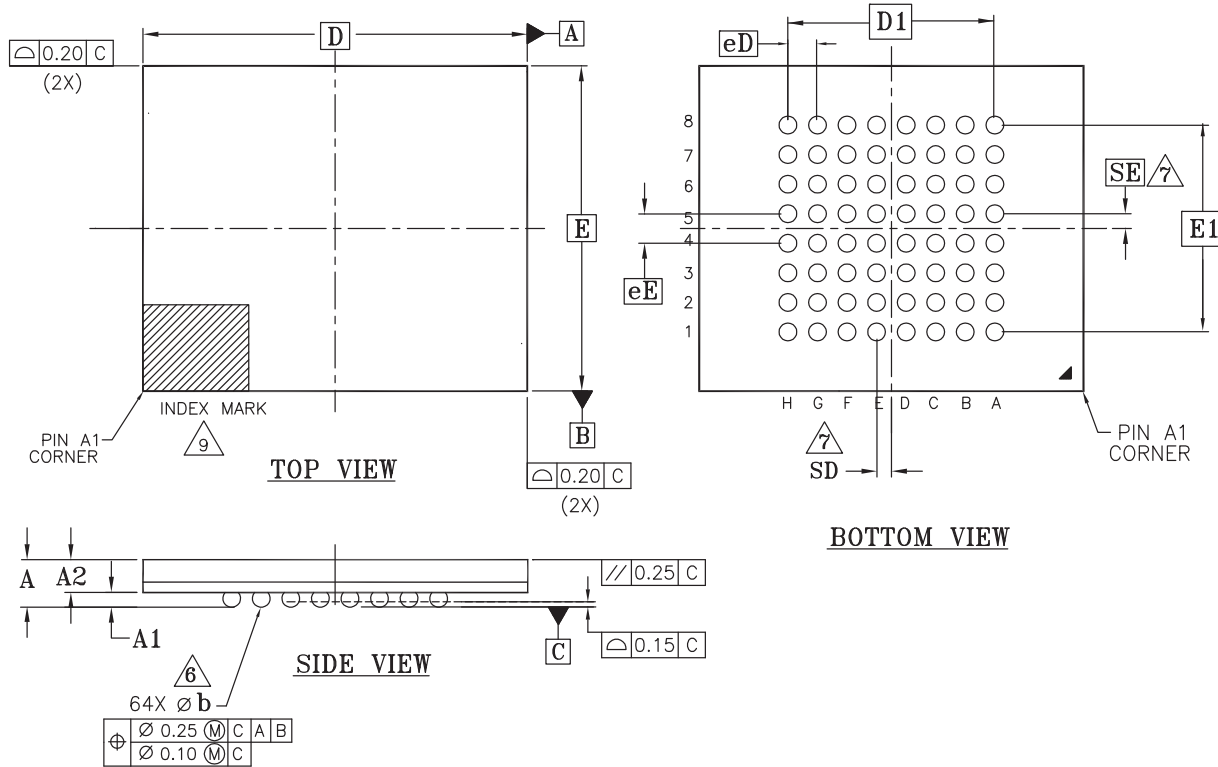

NOTES:

- DIMENSIONING AND TOLERANCING METHODS PER ASME Y14.5M-1994.
- ALL DIMENSIONS ARE IN MILLIMETERS.
- BALL POSITION DESIGNATION PER JEP95, SECTION 4.3, SPP-010.
- e REPRESENTS THE SOLDER BALL GRID PITCH.
- SYMBOL "MD" IS THE BALL MATRIX SIZE IN THE "D" DIRECTION.
SYMBOL "ME" IS THE BALL MATRIX SIZE IN THE "E" DIRECTION.
n IS THE NUMBER OF POPULATED SOLDER BALL POSITIONS FOR MATRIX SIZE MD X ME.
- DIMENSION "b" IS MEASURED AT THE MAXIMUM BALL DIAMETER IN A PLANE PARALLEL TO DATUM C.
- SD AND SE ARE MEASURED WITH RESPECT TO DATUMS A AND B AND DEFINE THE POSITION OF THE CENTER SOLDER BALL IN THE OUTER ROW.
WHEN THERE IS AN ODD NUMBER OF SOLDER BALLS IN THE OUTER ROW SD OR SE = 0.000.
WHEN THERE IS AN EVEN NUMBER OF SOLDER BALLS IN THE OUTER ROW, SD OR SE = $e/2$
- "+" INDICATES THE THEORETICAL CENTER OF DEPOPULATED BALLS.
- A1 CORNER TO BE IDENTIFIED BY CHAMFER, LASER OR INK MARK, METALLIZED MARK INDENTATION OR OTHER MEANS.

3611 / 16-038.15 / 11.13.6

3. Memory Map

The S70GL02GP consist of uniform 64 Kword (128 Kb) sectors organized as shown in [Table 2](#).

Table 2. S70GL02GP Sector & Memory Address Map

Uniform Sector Size	Sector Count	Sector Range	Address Range (16-bit)	Notes
64 Kword/128 Kb	2048	SA00	0000000h–000FFFFh	Sector Starting Address
		:	:	
		SA2047	7FF0000H–7FFFFFFH	Sector Ending Address

Note

This table has been condensed to show sector-related information for an entire device on a single page. Sectors and their address ranges that are not explicitly listed (such as SA001-SA2046) have sector starting and ending addresses that form the same pattern as all other sectors of that size. For example, all 128 Kb sectors have the pattern xxx0000h-xxxFFFFh.

4. Autoselect

[Table 3](#) provides the device identification codes for the S70GL02GP. For more information on the autoselect function, refer to the [S29GL01P datasheet](#).

Table 3. Autoselect Addresses in System

Description	Address	Read Data (word/byte mode)
Manufacturer ID	(Base) + 00h	xx01h/1h
Device ID, Word 1	(Base) + 01h	227Eh/7Eh
Device ID, Word 2	(Base) + 0Eh	2248h/48h
Device ID, Word 3	(Base) + 0Fh	2201h/01h
Secure Device Verify	(Base) + 03h	For S70GL02GPH: XX19h/19h = Not Factory Locked. XX99h/99h = Factory Locked. For S70GL02GPL: XX09h/09h = Not Factory Locked. XX89h/89h = Factory Locked.
Sector Protect Verify	(SA) + 02h	xx01h/01h = Locked, xx00h/00h = Unlocked

5. Erase And Programming Performance

Table 4. Erase And Programming Performance

Parameter	Typ (Note 1)	Max (Note 2)	Unit	Comments
Sector Erase Time	0.5	3.5	sec	Excludes 00h programming prior to erasure (Note 3)
Chip Erase Time	S70GL02GP	1024	4096	
Total Write Buffer Time, for 64 bytes	480		µs	Excludes system level overhead (Note 4)
Total Accelerated Write Buffer Programming Time, for 64 bytes	432		µs	
Chip Program Time	S70GL02GP	1968	sec	

Notes

1. Typical program and erase times assume the following conditions: 25°C, 3.6 V V_{CC}, 10,000 cycles, checkerboard pattern.
2. Under worst case conditions of -40°C, V_{CC} = 3.0 V, 100,000 cycles.
3. In the pre-programming step of the Embedded Erase algorithm, all bits are programmed to 00h before erasure.
4. System-level overhead is the time required to execute the two- or four-bus-cycle sequence for the program command.

6. BGA Package Capacitance

Parameter Symbol	Parameter Description	Test Setup	Typ	Max	Unit
C_{IN}	Input Capacitance	$V_{IN} = 0$	12	20	pF
C_{OUT}	Output Capacitance	$V_{OUT} = 0$	20	24	pF
C_{IN2}	Control Pin Capacitance	$V_{IN} = 0$	16	20	pF
RESET#, WP#/ACC	Separated Control Pin	$V_{IN} = 0$	84	90	pF
CE#	Separated Control Pin	$V_{IN} = 0$	44	50	pF

Notes

1. Sampled, not 100% tested.
2. Test conditions $T_A = 25^{\circ}\text{C}$, $f = 1.0\text{ MHz}$.

7. Revision History

Document History Page

Document Title: S70GL02GP, 2 Gbit, 3V Page Mode S70GL-P MirrorBit® Flash Document Number: 002-01338				
Rev.	ECN No.	Orig. of Change	Submission Date	Description of Change
**	—	RYSU	12/04/2006	Initial release
*A	—	RYSU	05/19/2008	Global: Changed data sheet designation Added Product Life-cycle notice Removed Table of Figures and Table of Tables Ordering Information: Changed sample OPN Added Commercial temperature range Changed configuration in "Device Number/description" Modified "Recommended Combination" table removed TSOP package option Erase And Program Performance: Chip Program Time - removed comment Common Flash Memory Interface: Removed section (see publication S29GL-P_00 for details)
*B	—	RYSU	02/23/2010	Global: Updated available model options. Corrected Chip Program Time.
*C	4950184	RYSU	10/06/2015	Updated to Cypress template
*D	5177489	RYSU	03/16/2016	Updated General Description and Distinctive Characteristics .

Sales, Solutions, and Legal Information

Worldwide Sales and Design Support

Cypress maintains a worldwide network of offices, solution centers, manufacturer's representatives, and distributors. To find the office closest to you, visit us at [Cypress Locations](#).

Products

ARM® Cortex® Microcontrollers	cypress.com/arm
Automotive	cypress.com/automotive
Clocks & Buffers	cypress.com/clocks
Interface	cypress.com/interface
Lighting & Power Control	cypress.com/powerpsoc
Memory	cypress.com/memory
PSoC	cypress.com/psoc
Touch Sensing	cypress.com/touch
USB Controllers	cypress.com/usb
Wireless/RF	cypress.com/wireless

PSoC® Solutions

cypress.com/psoc
[PSoC 1](#) | [PSoC 3](#) | [PSoC 4](#) | [PSoC 5LP](#)

Cypress Developer Community

[Community](#) | [Forums](#) | [Blogs](#) | [Video](#) | [Training](#)

Technical Support

cypress.com/support



© Cypress Semiconductor Corporation 2006-2016. This document is the property of Cypress Semiconductor Corporation and its subsidiaries, including Spansion LLC ("Cypress"). This document, including any software or firmware included or referenced in this document ("Software"), is owned by Cypress under the intellectual property laws and treaties of the United States and other countries worldwide. Cypress reserves all rights under such laws and treaties and does not, except as specifically stated in this paragraph, grant any license under its patents, copyrights, trademarks, or other intellectual property rights. If the Software is not accompanied by a license agreement and you do not otherwise have a written agreement with Cypress governing the use of the Software, then Cypress hereby grants you under its copyright rights in the Software, a personal, non-exclusive, nontransferable license (without the right to sublicense) (a) for Software provided in source code form, to modify and reproduce the Software solely for use with Cypress hardware products, only internally within your organization, and (b) to distribute the Software in binary code form externally to end users (either directly or indirectly through resellers and distributors), solely for use on Cypress hardware product units. Cypress also grants you a personal, non-exclusive, nontransferable, license (without the right to sublicense) under those claims of Cypress's patents that are infringed by the Software (as provided by Cypress, unmodified) to make, use, distribute, and import the Software solely to the minimum extent that is necessary for you to exercise your rights under the copyright license granted in the previous sentence. Any other use, reproduction, modification, translation, or compilation of the Software is prohibited.

CYPRESS MAKES NO WARRANTY OF ANY KIND, EXPRESS OR IMPLIED, WITH REGARD TO THIS DOCUMENT OR ANY SOFTWARE, INCLUDING, BUT NOT LIMITED TO, THE IMPLIED WARRANTIES OF MERCHANTABILITY AND FITNESS FOR A PARTICULAR PURPOSE. Cypress reserves the right to make changes to this document without further notice. Cypress does not assume any liability arising out of the application or use of any product or circuit described in this document. Any information provided in this document, including any sample design information or programming code, is provided only for reference purposes. It is the responsibility of the user of this document to properly design, program, and test the functionality and safety of any application made of this information and any resulting product. Cypress products are not designed, intended, or authorized for use as critical components in systems designed or intended for the operation of weapons, weapons systems, nuclear installations, life-support devices or systems, other medical devices or systems (including resuscitation equipment and surgical implants), pollution control or hazardous substances management, or other uses where the failure of the device or system could cause personal injury, death, or property damage ("Unintended Uses"). A critical component is any component of a device or system whose failure to perform can be reasonably expected to cause the failure of the device or system, or to affect its safety or effectiveness. Cypress is not liable, in whole or in part, and Company shall and hereby does release Cypress from any claim, damage, or other liability arising from or related to all Unintended Uses of Cypress products. Company shall indemnify and hold Cypress harmless from and against all claims, costs, damages, and other liabilities, including claims for personal injury or death, arising from or related to any Unintended Uses of Cypress products.

Cypress, the Cypress logo, Spansion, the Spansion logo, and combinations thereof, PSoC, CapSense, EZ-USB, F-RAM, and Traveo are trademarks or registered trademarks of Cypress in the United States and other countries. For a more complete list of Cypress trademarks, visit cypress.com. Other names and brands may be claimed as property of their respective owners.

Looking for pricing, stock, or lifecycle information?

Click below to explore more details on WIN SOURCE:

-  [View S70GL02GP11FAIR23 on WIN SOURCE](#)
-  [Cypress Semiconductor Corp Information](#)

Optimize Your Supply Chain with WIN SOURCE Solutions

-  Global Sourcing Solution
-  Obsolete Management
-  Cost Control Management
-  Shortage Management
-  Alternative Solution
-  Excess Inventory Management