



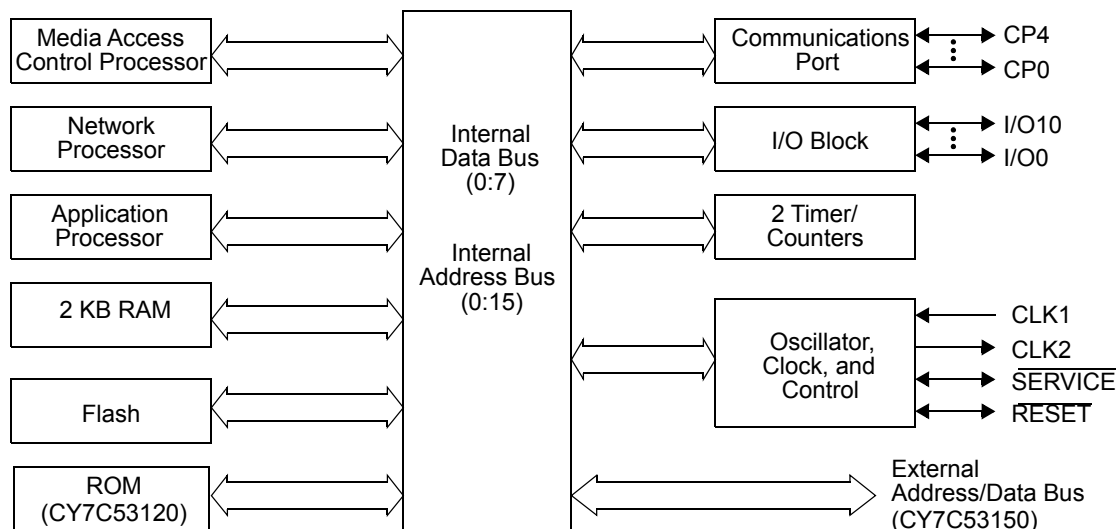
**THE DATASHEET OF  
CY7C53120E4-40AXI**



## Features

- Three 8-bit pipelined processors for concurrent processing of application code and network traffic
- 11-pin I/O port programmable in 34 modes for fast application program development
- Two 16-bit timer/counters for measuring and generating I/O device waveforms
- 5-pin communication port that supports direct connect and network transceiver interfaces
- Programmable pull-ups on I/O4–I/O7 and 20 mA sink current on I/O0–I/O3
- Unique 48-bit ID number in every device to facilitate network installation and management
- Low operating current; sleep mode operation for reduced current consumption<sup>[1]</sup>
- 0.35 μm flash process technology
- 5.0 V operation
- On-chip LVD circuit to prevent nonvolatile memory corruption during voltage drops
- 2,048 bytes of SRAM for buffering network data, system, and application data storage
- 512 bytes (CY7C53150), 2048 bytes (CY7C53120E2), 4096 bytes (CY7C53120E4) of Flash memory with on-chip charge pump for flexible storage of configuration data and application code
- Addresses up to 58 KB of external memory (CY7C53150)
- 10 KB (CY7C53120E2), 12 KB (CY7C53120E4) of ROM containing LonTalk network protocol firmware
- Maximum input clock operation of 20 MHz (CY7C53150), 10 MHz (CY7C53120E2), 40 MHz (CY7C53120E4) over a –40°C to 85°C<sup>[2]</sup> temperature range
- 64-pin TQFP package (CY7C53150)
- 32-pin SOIC or 44-pin TQFP package (CY7C53120)

## Logic Block Diagram



### Notes

1. Rare combinations of wake-up events occurring during the go to sleep sequence could produce unexpected sleep behavior.
2. Maximum Junction Temperature is 105 °C.  $T_{\text{Junction}} = T_{\text{Ambient}} + V \cdot I \cdot \theta_{\text{JA}}$ . 32-pin SOIC  $\theta_{\text{JA}} = 51$  °C/W. 44-pin TQFP  $\theta_{\text{JA}} = 43$  °C/W. 64-pin TQFP  $\theta_{\text{JA}} = 44$  °C/W.

**Contents**

<b>Functional Description</b> .....	<b>3</b>	<b>External Memory Interface Timing — CY7C53150</b> .....	<b>10</b>
<b>Pin Configurations</b> .....	<b>4</b>	<b>Differential Transceiver Electrical Characteristics</b> .....	<b>10</b>
<b>Pin Descriptions</b> .....	<b>6</b>	<b>Ordering Information[23]</b> .....	<b>14</b>
<b>Memory Usage</b> .....	<b>7</b>	Ordering Code Definitions .....	14
<b>Flash Memory Retention and Endurance</b> .....	<b>7</b>	<b>Package Diagrams</b> .....	<b>15</b>
<b>40 MHz 3120 Operation</b> .....	<b>7</b>	<b>Acronyms</b> .....	<b>17</b>
<b>Low Voltage Inhibit Operation</b> .....	<b>7</b>	<b>Document Conventions</b> .....	<b>17</b>
<b>Communications Port</b> .....	<b>7</b>	Units of Measure .....	17
Programmable Hysteresis Values .....	8	<b>Document History Page</b> .....	<b>18</b>
Programmable Glitch Filter Values <sup>[7]</sup> .....	8	<b>Sales, Solutions, and Legal Information</b> .....	<b>19</b>
Receiver <sup>[8]</sup> (End-to-End) Absolute Asymmetry .....	8	Worldwide Sales and Design Support .....	19
Differential Receiver (End-to-End)		Products .....	19
Absolute Symmetry <sup>[9, 10]</sup> .....	8	PSoC® Solutions .....	19
<b>Electrical Characteristics</b> .....	<b>9</b>	Cypress Developer Community .....	19
<b>LVI Trip Point (V<sub>DD</sub>)</b> .....	<b>9</b>	Technical Support .....	19

## Functional Description

The CY7C531x0 Neuron chip implements a node for LonWorks distributed intelligent control networks. It incorporates, on a single chip, the necessary communication and control functions, both in hardware and firmware, that facilitate the design of a LonWorks node.

The CY7C531x0 contains a very flexible 5-pin communication port that can be configured to interface with a wide variety of media transceivers at a wide range of data rates. The most common transceiver types are twisted-pair, powerline, RF, IR, fiber-optics, and coaxial.

The CY7C531x0 is manufactured using state of the art 0.35  $\mu\text{m}$  Flash technology, providing to designers the most cost-effective Neuron chip solution.

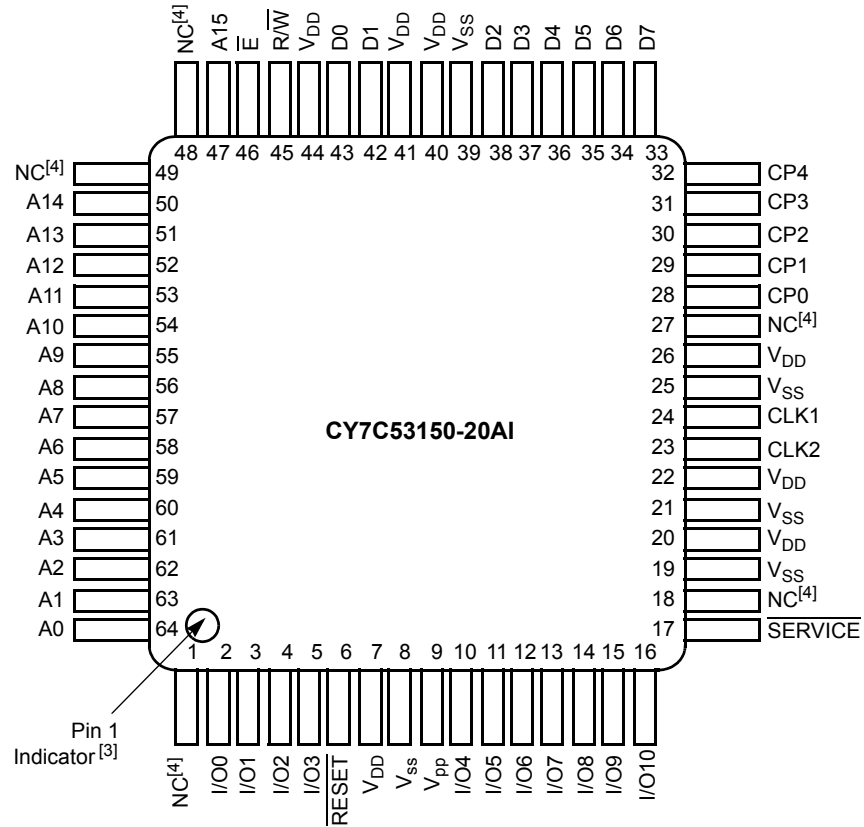
Services at every layer of the OSI networking reference model are implemented in the LonTalk firmware based protocol stored in 10-KB ROM (CY7C53120E2), 12-KB ROM (CY7C53120E4), or off-chip memory (CY7C53150). The firmware also contains 34 preprogrammed I/O drivers, greatly simplifying application programming. The application program is stored in the Flash memory (CY7C53120) and/or off-chip memory (CY7C53150), and may be updated by downloading over the network.

The CY7C53150 incorporates an external memory interface that can address up to 64 KB with 6 KB of the address space mapped internally. LonWorks nodes that require large application programs can take advantage of this external memory capability.

The CY7C53150 Neuron chip is an exact replacement for the Motorola MC143150Bx and Toshiba TMPN3150B1 devices. The CY7C53120E2 Neuron chip is an exact replacement for the Motorola MC143120E2 device since it contains the same firmware in ROM.

**Pin Configurations**

**Figure 1. 64-pin TQFP pinout**

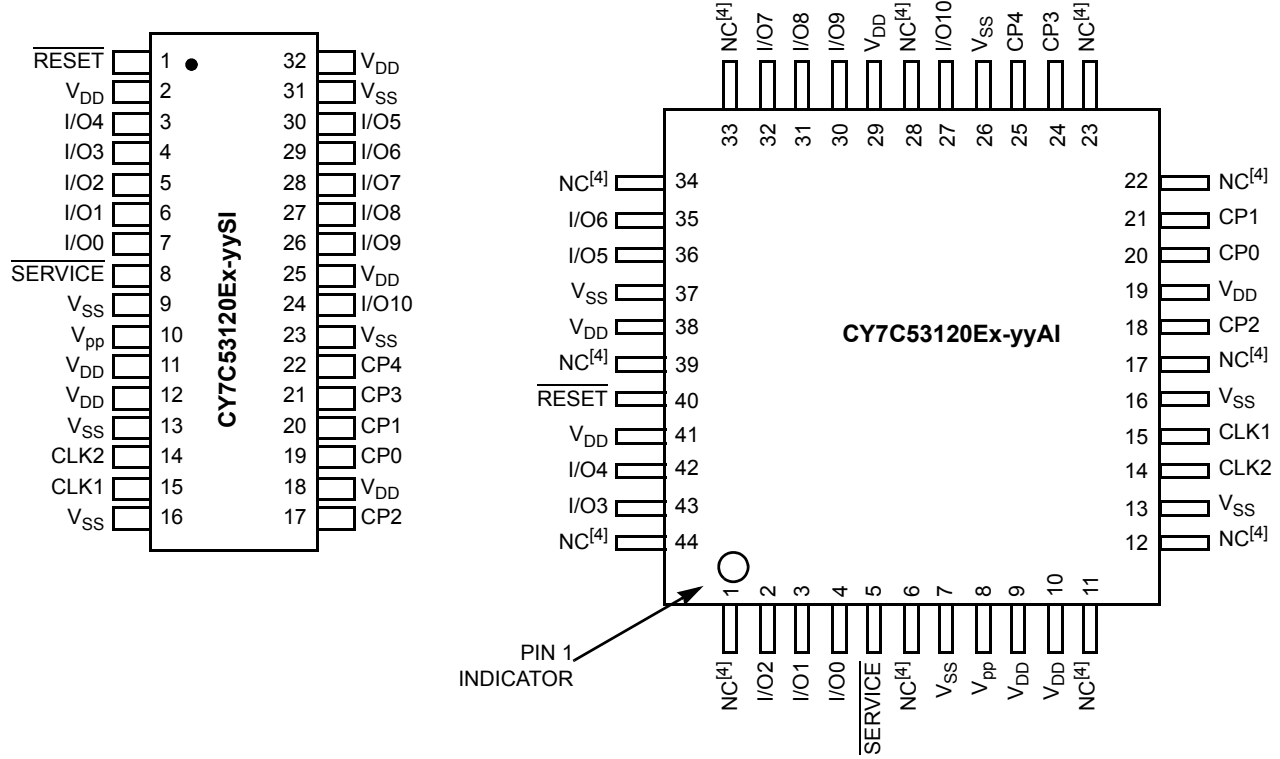


**Notes**

- 3. The smaller dimple at the bottom left of the marking indicates pin 1.
- 4. No Connect (NC) — Must not be used. (These pins may be used for internal testing.)

Pin Configurations (continued)

Figure 2. 32-pin SOIC pinout and 44-pin QFP pinout



## Pin Descriptions

Pin Name	I/O	Pin Function	CY7C53150 TQFP-64 Pin No.	CY7C53120xx SOIC-32 Pin No.	CY7C53120xx TQFP-44 Pin No.
CLK1	Input	<b>Oscillator connection or external clock input.</b>	24	15	15
CLK2	Output	<b>Oscillator connection.</b> Leave open when external clock is input to CLK1. Maximum of one external load.	23	14	14
RESET	I/O (Built-In Pull up)	<b>Reset pin (active LOW).</b> Note The allowable external capacitance connected to the RESET pin is 100–1000 pF.	6	1	40
SERVICE	I/O (Built-In Configurable Pull up)	<b>Service pin (active LOW).</b> Alternates between input and output at a 76-Hz rate.	17	8	5
I/O0–I/O3	I/O	<b>Large current-sink capacity (20 mA).</b> General I/O port. The output of timer/counter 1 may be routed to I/O0. The output of Timer/Counter 2 may be routed to I/O1.	2, 3, 4, 5	7, 6, 5, 4	4, 3, 2, 43
I/O4–I/O7	I/O (Built-In Configurable Pull ups)	<b>General I/O port.</b> The input to Timer/Counter 1 may be derived from one of I/O4–I/O7. The input to Timer/Counter 2 may be derived from I/O4.	10, 11, 12, 13	3, 30, 29, 28	42, 36, 35, 32
I/O8–I/O10	I/O	<b>General I/O port.</b> May be used for serial communication under firmware control.	14, 15, 16	27, 26, 24	31, 30, 27
D0–D7	I/O	<b>Bidirectional memory data bus.</b>	43, 42, 38, 37, 36, 35, 34, 33	N/A	N/A
R/W	Output	<b>Read/write control output for external memory.</b>	45	N/A	N/A
EN	Output	<b>Enable clock control output for external memory.</b>	46	N/A	N/A
A0–A15	Output	<b>Memory address output port.</b>	64, 63, 62, 61, 60, 59, 58, 57, 56, 55, 54, 53, 52, 51, 50, 47	N/A	N/A
V <sub>DD</sub>	Input	<b>Power input (5 V nom).</b> All V <sub>DD</sub> pins must be connected together externally.	7, 20, 22, 26, 40, 41, 44	2, 11, 12, 18, 25, 32	9, 10, 19, 29, 38, 41
V <sub>SS</sub>	Input	<b>Power input (0 V, GND).</b> All V <sub>SS</sub> pins must be connected together externally.	8, 19, 21, 25, 39	9, 13, 16, 23, 31	7, 13, 16, 26, 37
Vpp	Input	<b>In-circuit test mode control.</b> If Vpp is high when RESET is asserted, the I/O, address and data buses become Hi-Z.	9	10	8
CP0–CP4	Communication Network Interface	<b>Bidirectional port supporting communications in three modes.</b>	28, 29, 30, 31, 32	19, 20, 17, 21, 22	20, 21, 18, 24, 25
NC	—	<b>No connect.</b> Must not be connected on the user's PC board, since they may be connected internal to the chip.	1, 18, 27, 48, 49	N/A	1, 6, 11, 12, 17, 22, 23, 28, 33, 34, 39, 44

## Memory Usage

All Neuron chips require system firmware to be present when they are powered up. In the case of the CY7C53120 family, this firmware is preprogrammed in the factory in an on-chip ROM. In the case of the CY7C53150, the system firmware must be present in the first 16 KB of an off-chip nonvolatile memory such as Flash, EPROM, EEPROM, or NVRAM. These devices must be programmed in a device programmer before board assembly. Because the system firmware implements the network protocol, it cannot itself be downloaded over the network.

For the CY7C53120 family, the user application program is stored in on-chip Flash memory. It may be programmed using a device programmer before board assembly, or may be downloaded and updated over the LonTalk network from an external network management tool.

For the CY7C53150, the user application program is stored in on-chip Flash Memory and also in off-chip memory. The user program may initially be programmed into the off-chip memory device using a device programmer.

## Flash Memory Retention and Endurance

Data and code stored in Flash Memory is guaranteed to be retained for at least 10 years for programming temperature range of  $-25^{\circ}\text{C}$  to  $85^{\circ}\text{C}$ .

The Flash Memory can typically be written 100,000 times without any data loss.<sup>[5]</sup> An erase/write cycle takes 20 ms. The system firmware extends the effective endurance of Flash memory in two ways. If the data being written to a byte of Flash memory is the same as the data already present in that byte, the firmware does not perform the physical write. So for example, an application that sets its own address in Flash memory after every reset does not use up any write cycles if the address has not changed. In addition, system firmware version 13.1 or higher is able to aggregate writes to eight successive address locations into a single write for CY7C53120E4 devices. For example, if 4 KB of code is downloaded over the network, the firmware would execute only 512 writes rather than 4,096.

## 40 MHz 3120 Operation

The CY7C53120E4-40 device was designed to run at frequencies up to 40 MHz using an external clock oscillator. It is important to note that external oscillators may typically take on the order of 5 ms to stabilize after power-up. The Neuron chip must be held in reset until the CLK1 input is stable. With some oscillators, this may require the use of a reset-stretching Low-Voltage Detection chip/circuit. Check the oscillator vendor's specification for more information about start-up stabilization times.

## Low Voltage Inhibit Operation

The on-chip Low-voltage Inhibit circuit trips the Neuron chip whenever the  $V_{DD}$  input is less than  $4.1 \pm 0.3$  V. This feature prevents the corruption of nonvolatile memory during voltage drops.

## Communications Port

The Neuron chip includes a versatile 5-pin communications port that can be configured in three different ways. In Single-Ended Mode, pin CP0 is used for receiving serial data, pin CP1 for transmitting serial data, and pin CP2 enables an external transceiver. Data is communicated using Differential Manchester encoding.

In Special Purpose Mode, pin CP0 is used for receiving serial data, pin CP1 for transmitting serial data, pin CP2 transmits a bit clock, and pin CP4 transmits a frame clock for use by an external intelligent transceiver. In this mode, the external transceiver is responsible for encoding and decoding the data stream.

In Differential Mode, pins CP0 and CP1 form a differential receiver with built-in programmable hysteresis and low pass filtering. Pins CP2 and CP3 form a differential driver. Serial data is communicated using Differential Manchester encoding. The following tables describe the communications port when used in Differential Mode.

### Note

5. For detailed information about data retention after 100K cycles, see the Cypress qualification report.

**Programmable Hysteresis Values**

 (Expressed as differential peak-to-peak voltages in terms of  $V_{DD}$ )

Hysteresis <sup>[6]</sup>	$V_{hys}$ Min	$V_{hys}$ Typ	$V_{hys}$ Max
0	0.019 $V_{DD}$	0.027 $V_{DD}$	0.035 $V_{DD}$
1	0.040 $V_{DD}$	0.054 $V_{DD}$	0.068 $V_{DD}$
2	0.061 $V_{DD}$	0.081 $V_{DD}$	0.101 $V_{DD}$
3	0.081 $V_{DD}$	0.108 $V_{DD}$	0.135 $V_{DD}$
4	0.101 $V_{DD}$	0.135 $V_{DD}$	0.169 $V_{DD}$
5	0.121 $V_{DD}$	0.162 $V_{DD}$	0.203 $V_{DD}$
6	0.142 $V_{DD}$	0.189 $V_{DD}$	0.236 $V_{DD}$
7	0.162 $V_{DD}$	0.216 $V_{DD}$	0.270 $V_{DD}$

**Programmable Glitch Filter Values<sup>[7]</sup>**

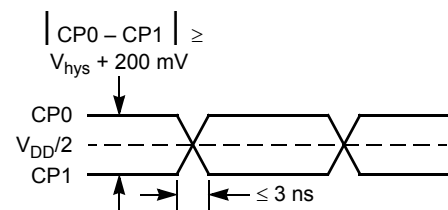
(Receiver (end-to-end) filter values expressed as transient pulse suppression times)

Filter (F)	Min	Typ	Max	Unit
0	10	75	140	ns
1	120	410	700	ns
2	240	800	1350	ns
3	480	1500	2600	ns

**Receiver<sup>[8]</sup> (End-to-End) Absolute Asymmetry**

(Worst case across hysteresis)

Filter (F)	Max ( $t_{PLH} - t_{PHL}$ )	Unit
0	35	ns
1	150	ns
2	250	ns
3	400	ns

**Figure 3. Receiver Input Waveform**

**Differential Receiver (End-to-End) Absolute Symmetry<sup>[9, 10]</sup>**

Filter (F)	Hysteresis (H)	Max ( $t_{PLH} - t_{PHL}$ )	Unit
0	0	24	ns

**Notes**

- Hysteresis values are on the condition that the input signal swing is 200 mV greater than the programmed value.
- Must be disabled if data rate is 1.25 Mbps or greater.
- Receiver input,  $V_D = V_{CP0} - V_{CP1}$ , at least 200 mV greater than hysteresis levels. See Figure 3.
- CPO and CP1 inputs each 0.60  $V_p - p$ , 1.25 MHz sine wave 180° out of phase with each other as shown in Figure 10.  $V_{DD} = 5.00 V \pm 5\%$ .
- $t_{PLH}$ : Time from input switching states from low to high to output switching states.  $t_{PHL}$ : Time from input switching states from high to low to output switching states.

## Electrical Characteristics

( $V_{DD} = 4.5\text{ V} - 5.5\text{ V}$ )

Parameter	Description	Min	Typ	Max	Unit
$V_{IL}$	Input Low Voltage I/O0–I/O10, CP0, CP3, CP4, $\overline{\text{SERVICE}}$ , D0–D7, $\overline{\text{RESET}}$ CP0, CP1 (Differential)	— —	— —	0.8 Programmable	V
$V_{IH}$	Input High Voltage I/O0–I/O10, CP0, CP3, CP4, $\overline{\text{SERVICE}}$ , D0–D7, $\overline{\text{RESET}}$ CP0, CP1 (Differential)	2.0 Programmable	— —	— —	V
$V_{OL}$	Low-Level Output Voltage $I_{out} < 20\ \mu\text{A}$ Standard Outputs ( $I_{OL} = 1.4\ \text{mA}$ ) <sup>[11]</sup> High Sink (I/O0–I/O3), $\overline{\text{SERVICE}}$ , $\overline{\text{RESET}}$ ( $I_{OL} = 20\ \text{mA}$ ) High Sink (I/O0–I/O3), $\overline{\text{SERVICE}}$ , $\overline{\text{RESET}}$ ( $I_{OL} = 10\ \text{mA}$ ) Maximum Sink (CP2, CP3) ( $I_{OL} = 40\ \text{mA}$ ) Maximum Sink (CP2, CP3) ( $I_{OL} = 15\ \text{mA}$ )	— — — — — —	— — — — — —	0.1 0.4 0.8 0.4 1.0 0.4	V
$V_{OH}$	High-Level Output Voltage $I_{out} < 20\ \mu\text{A}$ Standard Outputs ( $I_{OH} = -1.4\ \text{mA}$ ) <sup>[11]</sup> High Sink (I/O0 – I/O3), $\overline{\text{SERVICE}}$ ( $I_{OH} = -1.4\ \text{mA}$ ) Maximum Source (CP2, CP3) ( $I_{OH} = -40\ \text{mA}$ ) Maximum Source (CP2, CP3) ( $I_{OH} = -15\ \text{mA}$ )	$V_{DD} - 0.1$ $V_{DD} - 0.4$ $V_{DD} - 0.4$ $V_{DD} - 1.0$ $V_{DD} - 0.4$	— — — — —	— — — — —	V
$V_{hys}$	Hysteresis (Excluding CLK1)	175	—	—	mV
$I_{in}$	Input Current (Excluding Pull Ups) ( $V_{SS}$ to $V_{DD}$ ) <sup>[12]</sup>	—	—	$\pm 10$	$\mu\text{A}$
$I_{pu}$	Pull Up Source Current ( $V_{out} = 0\ \text{V}$ , Output = High-Z) <sup>[12]</sup>	60	—	260	$\mu\text{A}$
$I_{DD}$	Operating Mode Supply Current <sup>[13]</sup> 40-MHz Clock <sup>[14]</sup> 20-MHz Clock 10-MHz Clock 5-MHz Clock 2.5-MHz Clock 1.25-MHz Clock 0.625-MHz Clock <sup>[14]</sup>	— — — — — — —	— — — — — — —	55 32 20 12 8 7 3	mA
$I_{DDsleep}$	Sleep Mode Supply Current <sup>[1, 13]</sup>	—	—	100	$\mu\text{A}$

## LVI Trip Point ( $V_{DD}$ )

Part Number	Min	Typ	Max	Unit
CY7C53120E2, CY7C53120E4, and CY7C53150	3.8	4.1	4.4	V

### Notes

- Standard outputs are I/O4–I/O10, CP0, CP1, and CP4. ( $\overline{\text{RESET}}$  is an open drain input/output. CLK2 must have  $\leq 15\ \text{pF}$  load.) For CY7C53150, standard outputs also include A0–A15, D0–D7, E, and R/W.
- I/O4–I/O7 and  $\overline{\text{SERVICE}}$  have configurable pull ups.  $\overline{\text{RESET}}$  has a permanent pull up.
- Supply current measurement conditions:  $V_{DD} = 5\ \text{V}$ , all outputs under no-load conditions, all inputs  $\leq 0.2\ \text{V}$  or  $\geq (V_{DD} - 0.2\ \text{V})$ , configurable pull ups off, crystal oscillator clock input, differential receiver disabled. The differential receiver adds approximately  $200\ \mu\text{A}$  typical and  $600\ \mu\text{A}$  maximum when enabled. It is enabled on either of the following conditions:
  - Neuron chip in Operating mode **and** Comm Port in Differential mode.
  - Neuron chip in Sleep mode **and** Comm Port in Differential mode **and** Comm Port Wake-up not masked.
- Supported through an external oscillator only.

## External Memory Interface Timing — CY7C53150

 $V_{DD} \pm 10\%$  ( $V_{DD} = 4.5\text{ V to }5.5\text{ V}$ ,  $T_A = -40\text{ }^\circ\text{C to }+85\text{ }^\circ\text{C}$  [2])

Parameter	Description	Min	Max	Unit
$t_{cyc}$	Memory Cycle Time (System Clock Period) <sup>[15]</sup>	100	3200	ns
$PW_{EH}$	Pulse Width, $\bar{E}$ High <sup>[16]</sup>	$t_{cyc}/2 - 5$	$t_{cyc}/2 + 5$	ns
$PW_{EL}$	Pulse Width, $\bar{E}$ Low <sup>[16]</sup>	$t_{cyc}/2 - 5$	$t_{cyc}/2 + 5$	ns
$t_{AD}$	Delay, $\bar{E}$ High to Address Valid <sup>[20]</sup>	—	35	ns
$t_{AH}$	Address Hold Time After $\bar{E}$ High <sup>[20]</sup>	10	—	ns
$t_{RD}$	Delay, $\bar{E}$ High to R/ $\bar{W}$ Valid Read <sup>[20]</sup>	—	25	ns
$t_{RH}$	R/ $\bar{W}$ Hold Time Read After $\bar{E}$ High	5	—	ns
$t_{WR}$	Delay, $\bar{E}$ High to R/ $\bar{W}$ Valid Write	—	25	ns
$t_{WH}$	R/ $\bar{W}$ Hold Time Write After $\bar{E}$ High	5	—	ns
$t_{DSR}$	Read Data Setup Time to $\bar{E}$ High	15	—	ns
$t_{DHR}$	Data Hold Time Read After $\bar{E}$ High	0	—	ns
$t_{DHW}$	Data Hold Time Write After $\bar{E}$ High <sup>[17, 18]</sup>	10	—	ns
$t_{DDW}$	Delay, $\bar{E}$ Low to Data Valid	—	12	ns
$t_{DHZ}$	Data Three State Hold Time After $\bar{E}$ Low <sup>[19]</sup>	0	—	ns
$t_{DDZ}$	Delay, $\bar{E}$ High to Data Three-State <sup>[18]</sup>	—	42	ns
$t_{acc}$	External Memory Access Time ( $t_{acc} = t_{cyc} - t_{AD} - t_{DSR}$ ) at 20-MHz input clock	50	—	ns

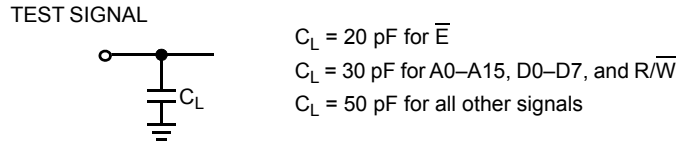
## Differential Transceiver Electrical Characteristics

Characteristic	Min	Max	Unit
Receiver Common Mode Voltage Range to maintain hysteresis <sup>[21]</sup>	1.2	$V_{DD} - 2.2$	V
Receiver Common Mode Range to operate with unspecified hysteresis	0.9	$V_{DD} - 1.75$	V
Input Offset Voltage	$-0.05 V_{hys} - 35$	$0.05 V_{hys} + 35$	mV
Propagation Delay ( $F = 0$ , $V_{ID} = V_{hys}/2 + 200\text{ mV}$ )	—	230 ns	ns
Input Resistance	5	—	$M\Omega$
Wake-up Time	—	10	$\mu\text{s}$
Differential Output Impedance for CP2 and CP3 <sup>[22]</sup>	—	35	$\Omega$

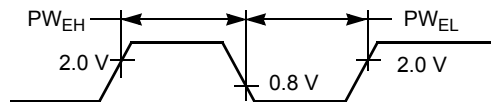
### Notes

15.  $t_{cyc} = 2(1/f)$ , where  $f$  is the input clock (CLK1) frequency (20, 10, 5, 2.5, 1.25, or 0.625 MHz).
16. Refer to Figure 5 for detailed measurement information.
17. The data hold parameter,  $t_{DHW}$ , is measured to the disable levels shown in Figure 7, rather than to the traditional data invalid levels.
18. Refer to Figure 8 and Figure 7 for detailed measurement information.
19. The three-state condition is when the device is not actively driving data. Refer to Figure 4 and Figure 7 for detailed measurement information.
20. To meet the timing above for 20-MHz operation, the loading on A0–A15, D0–D7, and R/ $\bar{W}$  is 30 pF. Loading on  $\bar{E}$  is 20 pF.
21. Common mode voltage is defined as the average value of the waveform at each input at the time switching occurs.
22.  $Z_0 = |V[CP2]-V[CP3]|/40\text{ mA}$  for  $4.75 \leq V_{DD} \leq 5.25\text{ V}$ .

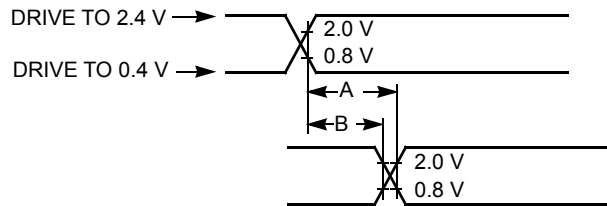
**Figure 4. Signal Loading for Timing Specifications Unless Otherwise Specified**



**Figure 5. Test Point Levels for  $\bar{E}$  Pulse Width Measurements**

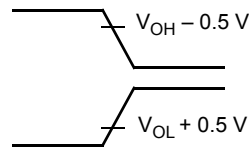


**Figure 6. Drive Levels and Test Point Levels for Timing Specifications Unless Otherwise Specified**



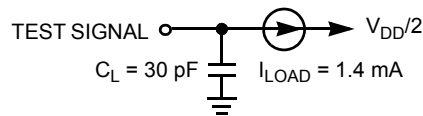
A — Signal valid-to-signal valid specification (maximum or minimum)  
 B — Signal valid-to-signal invalid specification (maximum or minimum)

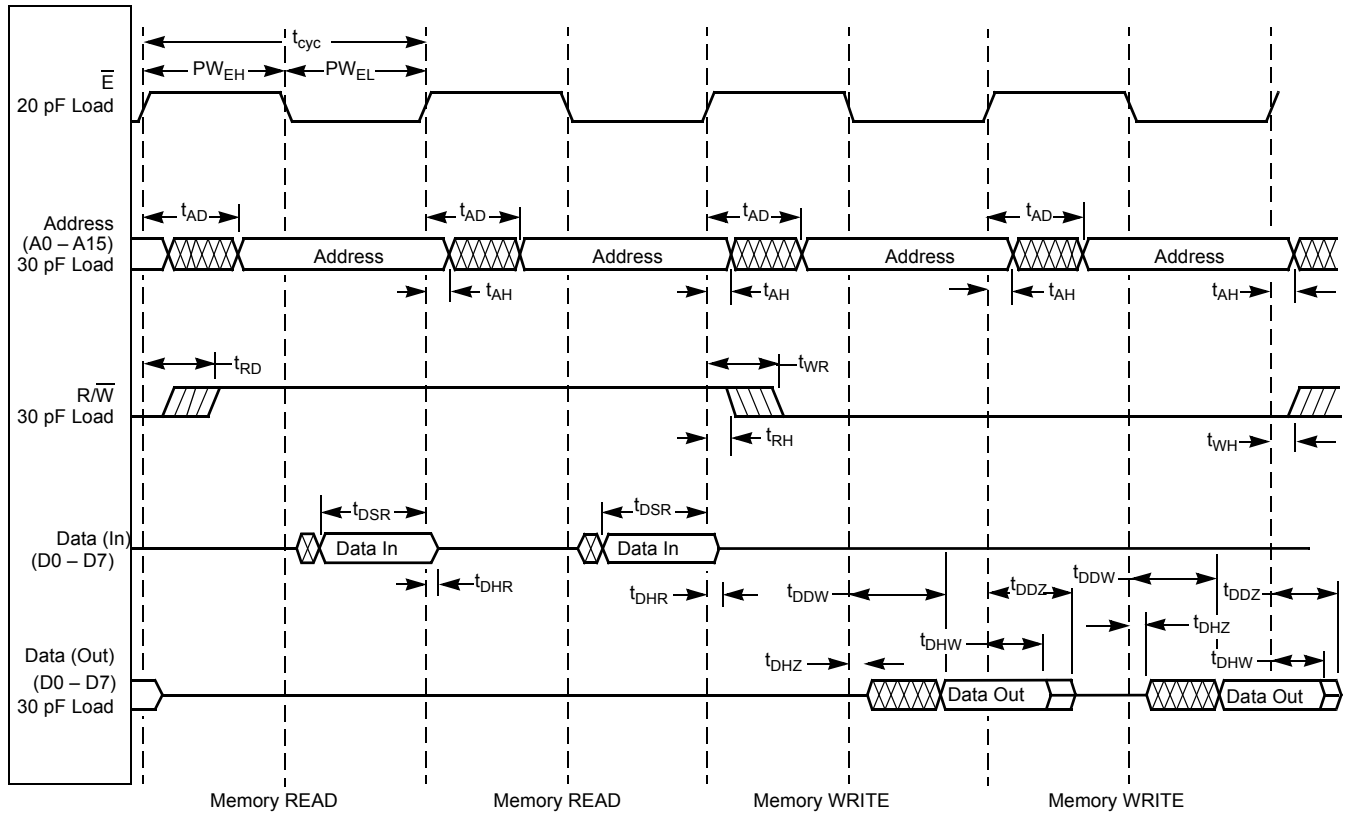
**Figure 7. Test Point Levels for Driven-to-Three-State Time Measurements**



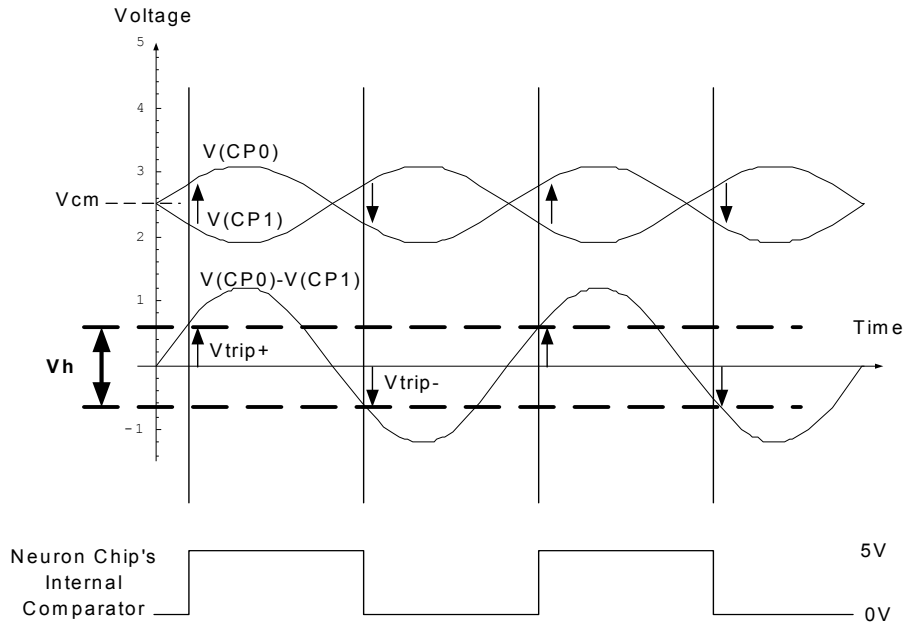
$V_{OH}$  — Measured high output drive level  
 $V_{OL}$  — Measured low output drive level

**Figure 8. Signal Loading for Driven-to-Three-State Time Measurements**



**Figure 9. External Memory Interface Timing Diagram**


**Figure 10. Differential Receiver Input Hysteresis Voltage Measurement Waveforms**



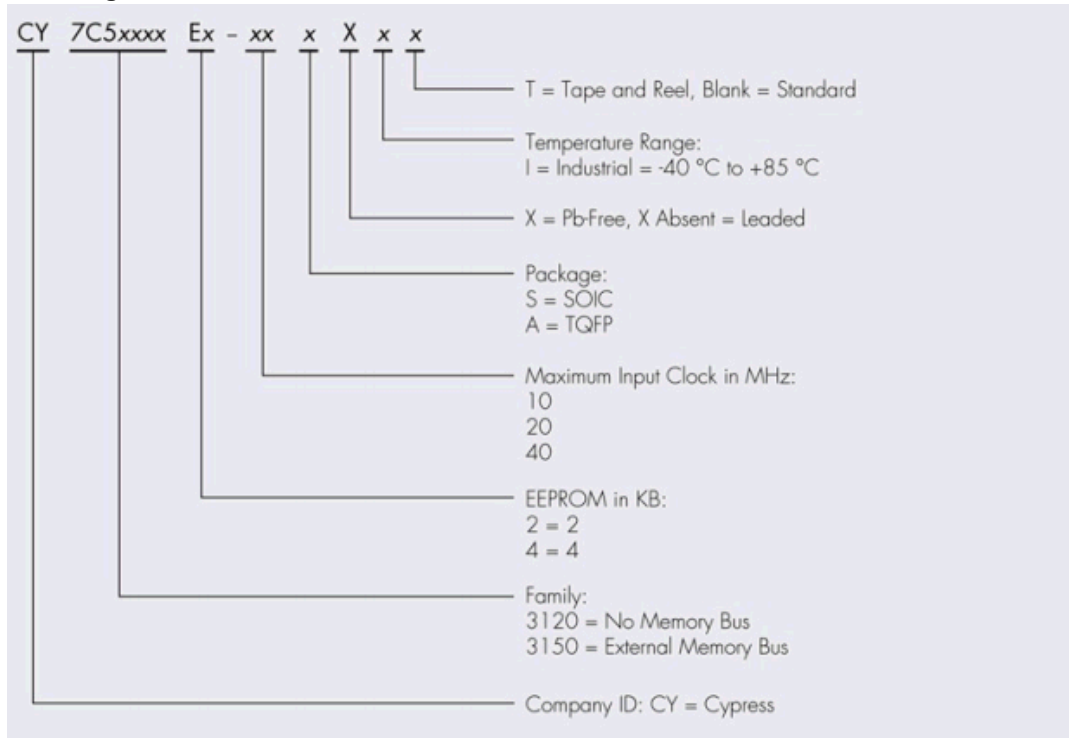
$$\text{Common-Mode voltage: } V_{cm} = (V(CP0) + V(CP1)) / 2$$

$$\text{Hysteresis Voltage: } V_h = [V_{trip+}] - [V_{trip-}]$$

**Ordering Information<sup>[23]</sup>**

Part Number	Flash (KB)	ROM (KB)	Firmware Version	Max Input Clock (MHz)	Package Name	Package Type
CY7C53150-20AXI	0.5	0	N/A	20 <sup>[24]</sup>	A64SA	64-pin TQFP
CY7C53150-20AXIT	0.5	0	N/A	20 <sup>[24]</sup>	A64SA	64-pin TQFP – Tape and Reel
CY7C53120E2-10SX <sup>[25]</sup>	2	10	6	10	S32.45	32-pin SOIC
CY7C53120E4-40SX <sup>[26]</sup>	4	12	13	40	S32.45	32-pin SOIC
CY7C53120E4-40SXIT	4	12	13	40	S32.45	32-pin SOIC – Tape and Reel
CY7C53120E4-40AX <sup>[26]</sup>	4	12	13	40	A44	44-pin TQFP

**Ordering Code Definitions**



**Notes**

- 23. All parts contain 2 KB of SRAM.
- 24. CY7C53150 may be used with 20-MHz input clock only if the firmware in external memory is version 13 or later.
- 25. CY7C53120E2 firmware is bit-for-bit identical with Motorola MC143120E2 firmware.
- 26. CY7C53120E4 requires upgraded LonBuilder® and NodeBuilder® software.

Package Diagrams

Figure 11. 44-pin TQFP (10 × 10 × 1.4 mm) Package Outline, 51-85064

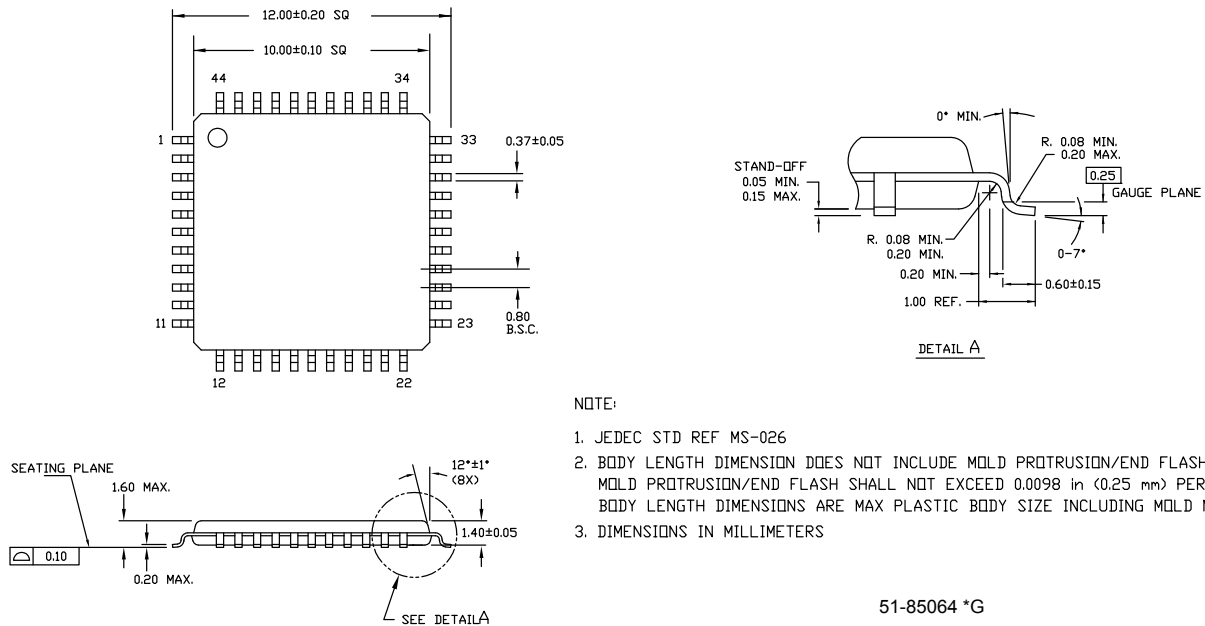
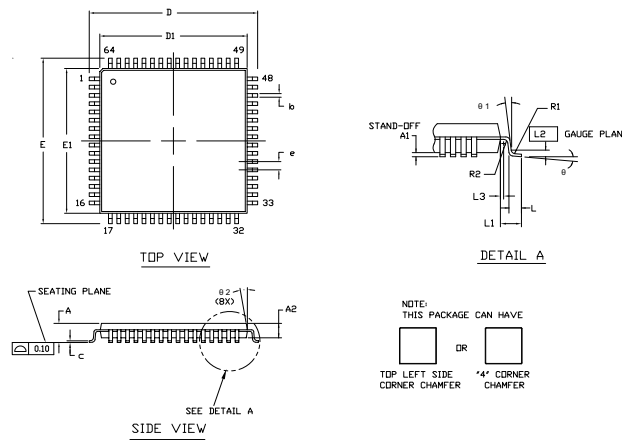


Figure 12. 64-pin TQFP (14 × 14 × 1.4 mm) Package Outline, 51-85046



SYMBOL	DIMENSIONS		
	MIN.	NOM.	MAX.
A	—	—	1.60
A1	0.05	—	0.15
A2	1.35	1.40	1.45
D	15.75	16.00	16.25
D1	13.95	14.00	14.05
E	15.75	16.00	16.25
E1	13.95	14.00	14.05
R1	0.08	—	0.20
R2	0.08	—	0.20
θ	0°	—	7°
θ1	0°	—	—
θ2	11°	12°	13°
c	—	—	0.20
b	0.30	0.35	0.40
L	0.45	0.60	0.75
L1	1.00	REF.	—
L2	—	0.25	BSC
L3	0.20	—	—
e	—	0.80	TYP

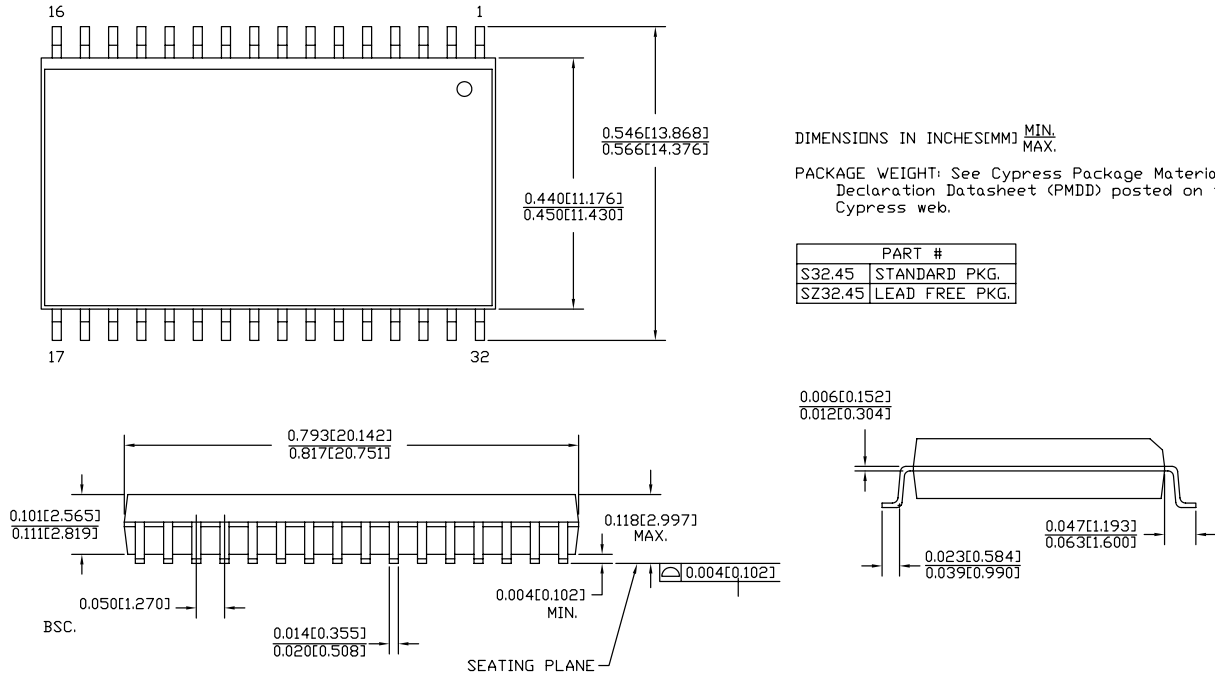
NOTE:

1. JEDEC STD REF MS-026
2. BODY LENGTH DIMENSION DOES NOT INCLUDE MOLD PROTRUSION/END FLASH  
MOLD PROTRUSION/END FLASH SHALL NOT EXCEED 0.0098 in (0.25 mm) PER SIDE  
BODY LENGTH DIMENSIONS ARE MAX PLASTIC BODY SIZE INCLUDING MOLD MISMATCH
3. DIMENSIONS IN MILLIMETERS

51-85046 \*H

Package Diagrams (continued)

Figure 13. 32-pin SOIC (450 Mils) Package Outline, 51-85081



51-85081 \*E

## Acronyms

Acronym	Description	Acronym	Description
AC	Alternating Current	LVD	Low Voltage Detect
CMOS	Complementary Metal Oxide Semiconductor	PCB	Printed Circuit Board
DC	Direct Current	PSoC <sup>®</sup>	Programmable System-on-Chip
EEPROM	Electrically Erasable Programmable Read-Only Memory	SOIC	Small-Outline Integrated Circuit
GPIO	General Purpose I/O	TQFP	Thin Quad Flat Pack

## Document Conventions

### Units of Measure

Symbol	Unit of Measure	Symbol	Unit of Measure
°C	degree Celsius	ms	millisecond
Hz	hertz	nA	nanoampere
kHz	kilohertz	ns	nanosecond
kΩ	kilohm	W	ohm
MHz	megahertz	%	percent
μA	microampere	pF	picofarad
μs	microsecond	V	volts
mA	milliampere	W	watt
mm	millimeter		

**Document History Page**

Document Title: CY7C53150, CY7C53120, Neuron Chip Network Processor Document Number: 38-10001				
Revision	ECN	Orig. of Change	Submission Date	Description of Change
**	111472	DSG	11/28/01	Change from Spec number: 38-00891 to 38-10001
*A	111990	CFB	02/06/02	Changed the max. current values Specified the Flash endurance of "100K typical" with reference to qual report Fixed some incorrect footnotes and figure numbering
*B	114465	KBO	04/24/02	Added Sleep Metastability footnote Added Junction Temperature footnote Added maximum sleep current footnote Changed "EEPROM" references to "Flash Memory"
*C	115269	KBO	04/26/02	Repositioned Note 3
*D	124450	KBO	03/25/03	Removed Note 2 regarding data retention Removed Note 16 regarding max sleep current Changed the system image firmware version from V12 to V13.1
*E	837840	BOO	3/14/07	Modified the Ordering Information table; added an "X" to indicate the part numbers are Pb-free; two tape-and-reel options are available now. Implemented new template.
*F	2811866	TGE	11/20/2009	Updated template. Modified Note 1 to add reference to the Neuron TRM.
*G	2899886	VED	03/26/10	Removed inactive part from the ordering information table. Updated package diagrams. Updated links in Sales, Solutions and Legal Information.
*H	3271364	REID / NJF / UVS / PKAR	06/01/11	Updated Ordering Information table: Firmware version for the following parts changed from 12 to 13. CY7C53120E4-40SXI CY7C53120E4-40SXIT CY7C53120E4-40AXI  Added Ordering code definitions  Added Acronyms, and Units of measure.  Revised package diagram specs 51-85064 and 51-85046 to *E.
*I	3540297	GNKK	03/02/2012	Sunset review; no content updates.
*J	4313266	PMAD	03/20/2014	Updated <a href="#">Features</a> : Updated Note 1.  Updated <a href="#">Package Diagrams</a> : spec 51-85064 – Changed revision from *E to *F. spec 51-85046 – Changed revision from *E to *F. spec 51-85081 – Changed revision from *D to *E.  Updated in new template.
*K	4695030	GRAA	03/20/2015	No content update
*L	5704101	AESATMP8	05/16/2017	Updated logo and Copyright.  Updated <a href="#">Package Diagrams</a> : spec 51-85064 – Changed revision from *F to *G. spec 51-85046 – Changed revision from *F to *H.

## Sales, Solutions, and Legal Information

### Worldwide Sales and Design Support

Cypress maintains a worldwide network of offices, solution centers, manufacturer's representatives, and distributors. To find the office closest to you, visit us at [Cypress Locations](#).

#### Products

ARM <sup>®</sup> Cortex <sup>®</sup> Microcontrollers	<a href="http://cypress.com/arm">cypress.com/arm</a>
Automotive	<a href="http://cypress.com/automotive">cypress.com/automotive</a>
Clocks & Buffers	<a href="http://cypress.com/clocks">cypress.com/clocks</a>
Interface	<a href="http://cypress.com/interface">cypress.com/interface</a>
Internet of Things	<a href="http://cypress.com/iot">cypress.com/iot</a>
Memory	<a href="http://cypress.com/memory">cypress.com/memory</a>
Microcontrollers	<a href="http://cypress.com/mcu">cypress.com/mcu</a>
PSoC	<a href="http://cypress.com/psoc">cypress.com/psoc</a>
Power Management ICs	<a href="http://cypress.com/pmhc">cypress.com/pmhc</a>
Touch Sensing	<a href="http://cypress.com/touch">cypress.com/touch</a>
USB Controllers	<a href="http://cypress.com/usb">cypress.com/usb</a>
Wireless Connectivity	<a href="http://cypress.com/wireless">cypress.com/wireless</a>

#### PSoC<sup>®</sup> Solutions

[PSoC 1](#) | [PSoC 3](#) | [PSoC 4](#) | [PSoC 5LP](#) | [PSoC 6](#)

#### Cypress Developer Community

[Forums](#) | [WICED IOT Forums](#) | [Projects](#) | [Video](#) | [Blogs](#) | [Training](#) | [Components](#)

#### Technical Support

[cypress.com/support](http://cypress.com/support)



© Cypress Semiconductor Corporation, 2001-2017. This document is the property of Cypress Semiconductor Corporation and its subsidiaries, including Spansion LLC ("Cypress"). This document, including any software or firmware included or referenced in this document ("Software"), is owned by Cypress under the intellectual property laws and treaties of the United States and other countries worldwide. Cypress reserves all rights under such laws and treaties and does not, except as specifically stated in this paragraph, grant any license under its patents, copyrights, trademarks, or other intellectual property rights. If the Software is not accompanied by a license agreement and you do not otherwise have a written agreement with Cypress governing the use of the Software, then Cypress hereby grants you a personal, non-exclusive, nontransferable license (without the right to sublicense) (1) under its copyright rights in the Software (a) for Software provided in source code form, to modify and reproduce the Software solely for use with Cypress hardware products, only internally within your organization, and (b) to distribute the Software in binary code form externally to end users (either directly or indirectly through resellers and distributors), solely for use on Cypress hardware product units, and (2) under those claims of Cypress's patents that are infringed by the Software (as provided by Cypress, unmodified) to make, use, distribute, and import the Software solely for use with Cypress hardware products. Any other use, reproduction, modification, translation, or compilation of the Software is prohibited.

TO THE EXTENT PERMITTED BY APPLICABLE LAW, CYPRESS MAKES NO WARRANTY OF ANY KIND, EXPRESS OR IMPLIED, WITH REGARD TO THIS DOCUMENT OR ANY SOFTWARE OR ACCOMPANYING HARDWARE, INCLUDING, BUT NOT LIMITED TO, THE IMPLIED WARRANTIES OF MERCHANTABILITY AND FITNESS FOR A PARTICULAR PURPOSE. To the extent permitted by applicable law, Cypress reserves the right to make changes to this document without further notice. Cypress does not assume any liability arising out of the application or use of any product or circuit described in this document. Any information provided in this document, including any sample design information or programming code, is provided only for reference purposes. It is the responsibility of the user of this document to properly design, program, and test the functionality and safety of any application made of this information and any resulting product. Cypress products are not designed, intended, or authorized for use as critical components in systems designed or intended for the operation of weapons, weapons systems, nuclear installations, life-support devices or systems, other medical devices or systems (including resuscitation equipment and surgical implants), pollution control or hazardous substances management, or other uses where the failure of the device or system could cause personal injury, death, or property damage ("Unintended Uses"). A critical component is any component of a device or system whose failure to perform can be reasonably expected to cause the failure of the device or system, or to affect its safety or effectiveness. Cypress is not liable, in whole or in part, and you shall and hereby do release Cypress from any claim, damage, or other liability arising from or related to all Unintended Uses of Cypress products. You shall indemnify and hold Cypress harmless from and against all claims, costs, damages, and other liabilities, including claims for personal injury or death, arising from or related to any Unintended Uses of Cypress products.

Cypress, the Cypress logo, Spansion, the Spansion logo, and combinations thereof, WICED, PSoC, CapSense, EZ-USB, F-RAM, and Traveo are trademarks or registered trademarks of Cypress in the United States and other countries. For a more complete list of Cypress trademarks, visit [cypress.com](http://cypress.com). Other names and brands may be claimed as property of their respective owners.

## Looking for pricing, stock, or lifecycle information?

Click below to explore more details on WIN SOURCE:

-  [View CY7C53120E4-40AXI on WIN SOURCE](#)
-  [Cypress Semiconductor Corp Information](#)

## Optimize Your Supply Chain with WIN SOURCE Solutions

-  Global Sourcing Solution
-  Obsolete Management
-  Cost Control Management
-  Shortage Management
-  Alternative Solution
-  Excess Inventory Management