



**THE DATASHEET OF
SN74LVC257APWRG4**



SNx4LVC257A Quadruple 2-Line to 1-Line Data Selectors and Multiplexers With 3-State Outputs

1 Features

- Operate from 1.65V to 3.6V
- Inputs accept voltages to 5.5V
- Maximum t_{pd} of 4.6ns at 3.3V
- Typical V_{OLP} (output ground bounce) <0.8V at $V_{CC} = 3.3V$, $T_A = 25^\circ C$
- Typical V_{OHV} (output V_{OH} undershoot) >2V at $V_{CC} = 3.3V$, $T_A = 25^\circ C$
- Latch-up performance exceeds 250mA per JESD 17
- ESD protection exceeds JESD 22
 - 2000V human-body model (A114-A)
 - 200V machine model (A115-A)
- On products compliant to MIL-PRF-38535, all parameters are tested unless otherwise noted. On all other products, production processing does not necessarily include testing of all parameters.

2 Applications

- Cable Modem Termination Systems
- Tests and Measurements
- I/O Expanders
- Motor Drivers
- Network Switches
- Servers
- Telecom Infrastructure

3 Description

These quadruple 2-line to 1-line data selectors and multiplexers are designed for 1.65V to 3.6V V_{CC} operation.

The SNx4LVC257A devices are designed to multiplex signals from 4-bit data sources to 4-output data lines in bus-organized systems. The 3-state outputs do not load the data lines when the output-enable (\overline{OE}) input is at a high logic level.

Inputs can be driven from either 3.3V or 5V devices. This feature allows the use of these devices as translators in a mixed 3.3V or 5V system environment.

Device Information

PART NUMBER	PACKAGE ⁽¹⁾	PACKAGE SIZE ⁽²⁾	BODY SIZE ⁽³⁾
SNx4LVC257A	BQB (WQFN, 16)	3.5mm × 2.5mm	3.5mm × 2.5mm
	D (SOIC, 16)	9.90 mm × 6mm	9.90 mm × 3.90 mm
	DB (SSOP, 16)	6.20 mm × 7.8mm	6.20 mm × 5.30 mm
	NS (SOP, 16)	5mm × 6.4mm	5mm × 4.4mm
	PW (TSSOP, 16)	5.00 mm × 6.4mm	5.00 mm × 4.40 mm
	RGY (VQFN, 16)	4mm × 3.5mm	4mm × 3.5mm

- For more information, see [Mechanical, Packaging, and Orderable Information](#).
- The package size (length × width) is a nominal value and includes pins, where applicable.
- The body size (length × width) is a nominal value and does not include pins.

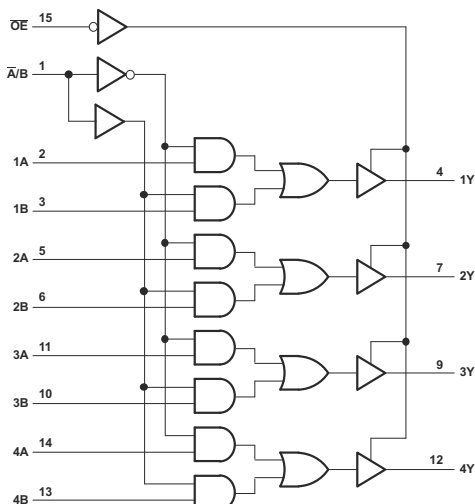

Pin numbers shown are for the D, DB, J, NS, PW, RGY, and W packages.

Logic Diagram (Positive Logic)



Table of Contents

1 Features	1	7.1 Overview.....	9
2 Applications	1	7.2 Functional Block Diagram.....	9
3 Description	1	7.3 Feature Description.....	9
4 Pin Configuration and Functions	3	7.4 Device Functional Modes.....	9
5 Specifications	4	8 Device and Documentation Support	13
5.1 Absolute Maximum Ratings.....	4	8.1 Documentation Support (Analog).....	13
5.2 ESD Ratings.....	4	8.2 Community Resources.....	13
5.3 Recommended Operating Conditions.....	4	8.3 Receiving Notification of Documentation Updates... 13	
5.4 Thermal Information.....	5	8.4 Support Resources.....	13
5.5 Electrical Characteristics.....	5	8.5 Trademarks.....	13
5.6 Switching Characteristics, SN54LVC257A	6	8.6 Electrostatic Discharge Caution.....	13
5.7 Switching Characteristics, SN74LVC257A	6	8.7 Glossary.....	13
5.8 Operating Characteristics.....	6	9 Revision History	13
5.9 Typical Characteristics.....	7	10 Mechanical, Packaging, and Orderable Information	14
6 Parameter Measurement Information	8		
7 Detailed Description	9		

4 Pin Configuration and Functions

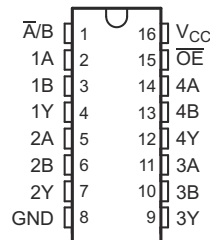

Figure 4-1. D, DB, NS, J, W, or PW Package; 16-Pin SOIC, SSOP, SO, CDIP, CFP, or TSSOP (Top View)

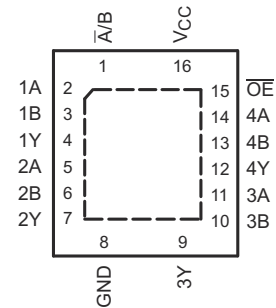

Figure 4-2. BQB or RGY Package; 16-Pin WQFN or VQFN with Exposed Thermal Pad (Top View)

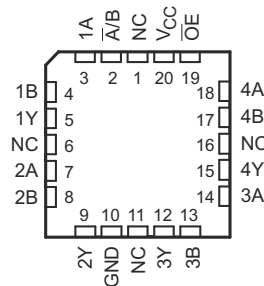

Figure 4-3. FK Package, 20-Pin LCCC Top View

NAME	PIN		I/O	DESCRIPTION
	SOIC, SSOP, SO, CDIP, CFP, TSSOP, WQFN, or VQFN	LCCC		
\bar{A}/B	1	2	I	Select Pin, Low selects A, High selects B
1A	2	3	I/O	Multiplexer Signal Input
1B	3	4	I/O	Multiplexer Signal Input
1Y	4	5	I/O	Multiplexer Output
2A	5	7	I/O	Multiplexer Signal Input
2B	6	8	I/O	Multiplexer Signal Input
2Y	7	9	I/O	Multiplexer Output
3A	11	14	I/O	Multiplexer Signal Input
3B	10	13	I/O	Multiplexer Signal Input
3Y	9	12	I/O	Multiplexer Output
4A	14	18	I/O	Multiplexer Signal Input
4B	13	17	I/O	Multiplexer Signal Input
4Y	12	15	I/O	Multiplexer Output
GND	8	10	—	Ground
NC ⁽¹⁾	—	1, 6, 11, 16	—	No connect
\overline{OE}	15	19	I/O	Active low Output enable
V_{CC}	16	20	—	Power pin

(1) NC – no internal connection

5 Specifications

5.1 Absolute Maximum Ratings

over operating free-air temperature range (unless otherwise noted)⁽¹⁾

		MIN	MAX	UNIT
V _{CC}	Supply voltage	-0.5	6.5	V
V _I	Input voltage ⁽²⁾	-0.5	6.5	V
V _O	Output voltage ^{(2) (3)}	-0.5	V _{CC} + 0.5	V
I _{IK}	Input clamp current	V _I < 0		mA
I _{OK}	Output clamp current	V _O < 0		mA
I _O	Continuous output current			±50
	Continuous current through V _{CC} or GND			±100
T _{stg}	Storage temperature	-65	150	°C

- (1) Stresses beyond those listed under *Absolute Maximum Ratings* may cause permanent damage to the device. These are stress ratings only, which do not imply functional operation of the device at these or any other conditions beyond those indicated under *Recommended Operating Conditions*. Exposure to absolute-maximum-rated conditions for extended periods may affect device reliability.
- (2) The input negative-voltage and output voltage ratings may be exceeded if the input and output current ratings are observed.
- (3) The value of V_{CC} is provided in the recommended operating conditions table.

5.2 ESD Ratings

		VALUE	UNIT
V _(ESD)	Electrostatic discharge	Human body model (HBM), per ANSI/ESDA/JEDEC JS-001, all pins ⁽¹⁾	±2000
		Charged-device model (CDM), per JEDEC specification JESD22-C101, all pins ⁽²⁾	±1000

- (1) JEDEC document JEP155 states that 500-V HBM allows safe manufacturing with a standard ESD control process.
- (2) JEDEC document JEP157 states that 250-V CDM allows safe manufacturing with a standard ESD control process.

5.3 Recommended Operating Conditions

over operating free-air temperature range (unless otherwise noted)⁽¹⁾

		SN54LVC257A		SN74LVC257A		UNIT
		MIN	MAX	MIN	MAX	
V _{CC}	Supply voltage	Operating		2	3.6	V
		Data retention only		1.5		
V _{IH}	High-level input voltage	V _{CC} = 1.65 V to 1.95 V		0.65 × V _{CC}		V
		V _{CC} = 2.3 V to 2.7 V		1.7		
		V _{CC} = 2.7 V to 3.6 V		2	2	
V _{IL}	Low-level input voltage	V _{CC} = 1.65 V to 1.95 V		0.35 × V _{CC}		V
		V _{CC} = 2.3 V to 2.7 V		0.7		
		V _{CC} = 2.7 V to 3.6 V		0.8		
V _I	Input voltage	0	5.5	0	5.5	V
V _O	Output voltage	0	V _{CC}	0	V _{CC}	V
I _{OH}	High-level output current	V _{CC} = 1.65 V		-4		mA
		V _{CC} = 2.3 V		-8		
		V _{CC} = 2.7 V		-12	-12	
		V _{CC} = 3 V		-24	-24	
I _{OL}	Low-level output current	V _{CC} = 1.65 V		4		mA
		V _{CC} = 2.3 V		8		
		V _{CC} = 2.7 V		12	12	
		V _{CC} = 3 V		24	24	

over operating free-air temperature range (unless otherwise noted)⁽¹⁾

		SN54LVC257A		SN74LVC257A		UNIT
		MIN	MAX	MIN	MAX	
$\Delta t/\Delta v$	Input transition rise or fall rate		10		10	ns/V
T_A	Operating free-air temperature	-55	125	-40	85	°C

(1) All unused inputs of the device must be held at V_{CC} or GND to ensure proper device operation. Refer to the TI application report, *Implications of Slow or Floating CMOS Inputs*, [SCBA004](#).

5.4 Thermal Information

THERMAL METRIC ⁽¹⁾		SN74LVC257A						UNIT
		BQB (WQFN)	D (SOIC)	DB (SSOP)	NS (SO)	PW (TSSOP)	RGY	
		16 PINS						
$R_{\theta JA}$	Junction-to-ambient thermal resistance	98.8	73	82	64	108	39	°C/W

(1) For more information about traditional and new thermal metrics, see the *Semiconductor and IC Package Thermal Metrics* application report, [SPRA953](#).

5.5 Electrical Characteristics

over recommended operating free-air temperature range (unless otherwise noted)

PARAMETER	TEST CONDITIONS	V_{CC}	SN54LVC257A			SN74LVC257A			UNIT
			MIN	TYP ⁽¹⁾	MAX	MIN	TYP ⁽¹⁾	MAX	
V_{OH}	$I_{OH} = -100 \mu A$	1.65 V to 3.6 V				$V_{CC} - 0.2$			V
	$I_{OH} = -100 \mu A$	2.7 V to 3.6 V	$V_{CC} - 0.2$						
	$I_{OH} = -4 \text{ mA}$	1.65 V				1.2			
	$I_{OH} = -8 \text{ mA}$	2.3 V				1.7			
	$I_{OH} = -12 \text{ mA}$	2.7 V	2.2			2.2			
		3 V	2.4			2.4			
$I_{OH} = -24 \text{ mA}$	3 V	2.2			2.2				
V_{OL}	$I_{OL} = 100 \mu A$	1.65 V to 3.6 V				0.2			V
		2.7 V to 3.6 V	0.2						
	$I_{OL} = 4 \text{ mA}$	1.65 V				0.45			
	$I_{OL} = 8 \text{ mA}$	2.3 V				0.7			
	$I_{OL} = 12 \text{ mA}$	2.7 V	0.4			0.4			
$I_{OL} = 24 \text{ mA}$	3 V	0.55			0.55				
I_I	$V_I = 5.5 \text{ V or GND}$	3.6 V				± 5			μA
I_{OZ}	$V_O = V_{CC} \text{ or GND}$	3.6 V				± 15			μA
I_{CC}	$V_I = V_{CC} \text{ or GND, } I_O = 0$	3.6 V				10			μA
ΔI_{CC}	One input at $V_{CC} - 0.6 \text{ V}$, Other inputs at $V_{CC} \text{ or GND}$	2.7 V to 3.6 V				500			μA
C_i	$V_I = V_{CC} \text{ or GND}$	3.3 V				5			pF
C_o	$V_O = V_{CC} \text{ or GND}$	3.3 V				5			pF

(1) All typical values are at $V_{CC} = 3.3 \text{ V}$, $T_A = 25^\circ\text{C}$.

5.6 Switching Characteristics, SN54LVC257A

over recommended operating free-air temperature range (unless otherwise noted) (see [Load Circuit and Voltage Waveforms](#))

PARAMETER	FROM (INPUT)	TO (OUTPUT)	SN54LVC257A				UNIT
			V _{CC} = 2.7 V		V _{CC} = 3.3 V ± 0.3 V		
			MIN	MAX	MIN	MAX	
t _{pd}	A or B	Y	5.4		1	4.6	ns
	\bar{A}/B		7.5		1	6.4	
t _{en}	\overline{OE}	Y	6.7		1	5.6	ns
t _{dis}	\overline{OE}	Y	4.7		0.5	4.3	ns
t _{sk(o)}					1		ns

5.7 Switching Characteristics, SN74LVC257A

over recommended operating free-air temperature range (unless otherwise noted) (see [Load Circuit and Voltage Waveforms](#))

PARAMETER	FROM (INPUT)	TO (OUTPUT)	SN74LVC257A								UNIT
			V _{CC} = 1.8 V ± 0.15 V		V _{CC} = 2.5 V ± 0.2 V		V _{CC} = 2.7 V		V _{CC} = 3.3 V ± 0.3 V		
			MIN	MAX	MIN	MAX	MIN	MAX	MIN	MAX	
t _{pd}	A or B	Y	1	13.5	1	7.4	1	5.4	1	4.6	ns
	\bar{A}/B		1	15.6	1	9.5	1	7.5	1	6.4	
t _{en}	\overline{OE}	Y	1	14.6	1	8.7	1	6.7	1	5.6	ns
t _{dis}	\overline{OE}	Y	1	15.4	1	6.7	1	4.7	1	4.3	ns
t _{sk(o)}									1		ns

5.8 Operating Characteristics

T_A = 25°C

PARAMETER	TEST CONDITIONS	V _{CC} = 1.8 V	V _{CC} = 2.5 V	V _{CC} = 3.3 V	UNIT	
		TYP	TYP	TYP		
C _{pd}	Power dissipation capacitance	f = 10 MHz	13.5	14.5	15.5	pF

5.9 Typical Characteristics

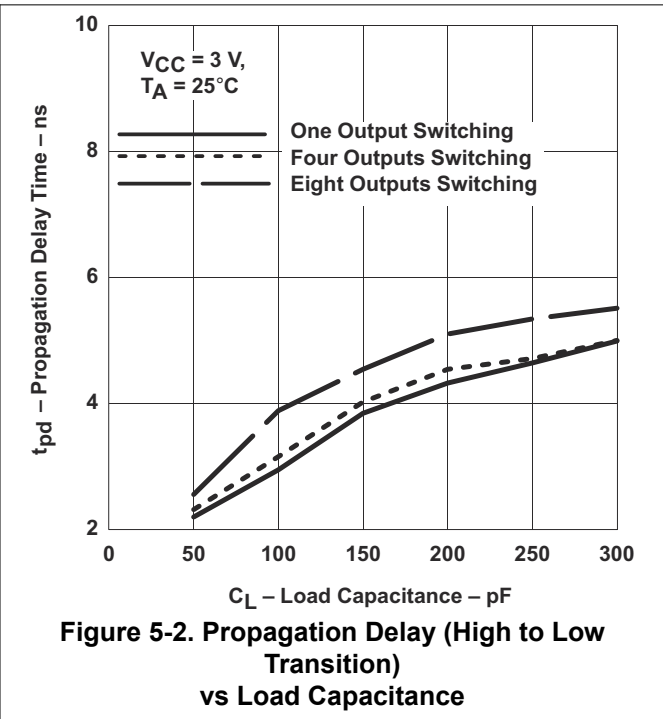
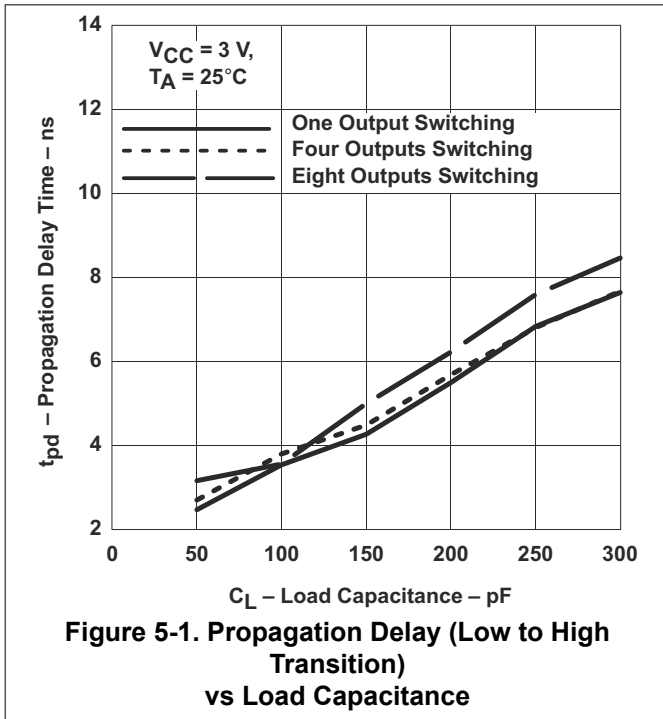

6 Parameter Measurement Information

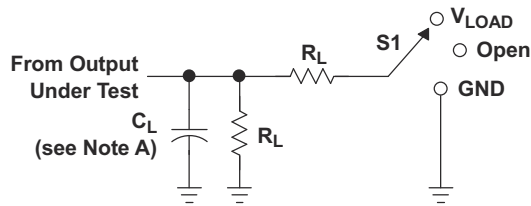

LOAD CIRCUIT

TEST	S1
t_{PLH}/t_{PHL}	Open
t_{PLZ}/t_{PZL}	V_{LOAD}
t_{PHZ}/t_{PZH}	GND

V_{CC}	INPUTS		V_M	V_{LOAD}	C_L	R_L	V_{Δ}
	V_I	t_r/t_f					
1.8 V \pm 0.15 V	V_{CC}	≤ 2 ns	$V_{CC}/2$	$2 \times V_{CC}$	30 pF	1 k Ω	0.15 V
2.5 V \pm 0.2 V	V_{CC}	≤ 2 ns	$V_{CC}/2$	$2 \times V_{CC}$	30 pF	500 Ω	0.15 V
2.7 V	2.7 V	≤ 2.5 ns	1.5 V	6 V	50 pF	500 Ω	0.3 V
3.3 V \pm 0.3 V	2.7 V	≤ 2.5 ns	1.5 V	6 V	50 pF	500 Ω	0.3 V

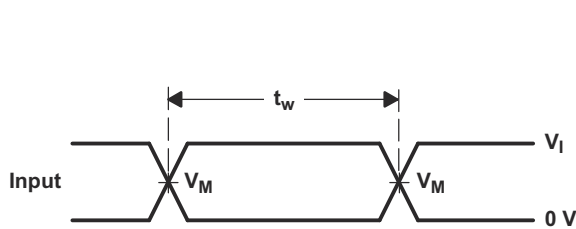

VOLTAGE WAVEFORMS
PULSE DURATION

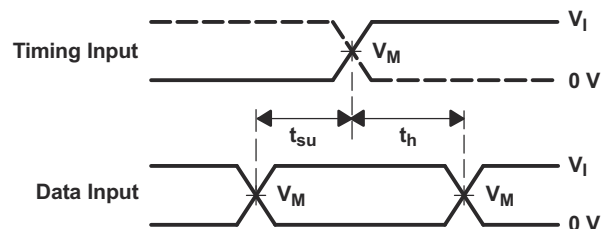

VOLTAGE WAVEFORMS
SETUP AND HOLD TIMES

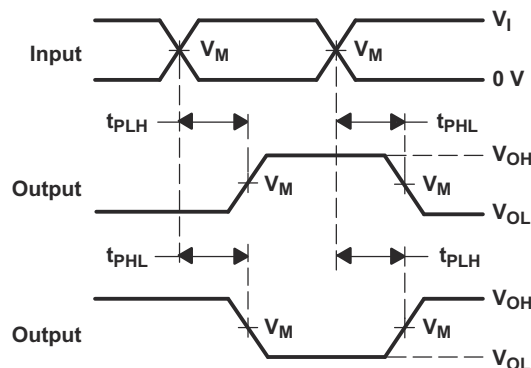

VOLTAGE WAVEFORMS
PROPAGATION DELAY TIMES
INVERTING AND NONINVERTING OUTPUTS

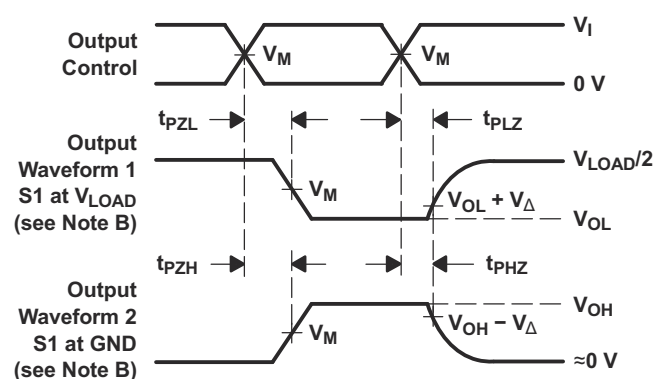

VOLTAGE WAVEFORMS
ENABLE AND DISABLE TIMES
LOW- AND HIGH-LEVEL ENABLING

- NOTES:
- C_L includes probe and jig capacitance.
 - Waveform 1 is for an output with internal conditions such that the output is low except when disabled by the output control. Waveform 2 is for an output with internal conditions such that the output is high, except when disabled by the output control.
 - All input pulses are supplied by generators having the following characteristics: PRR ≤ 10 MHz, $Z_O = 50 \Omega$.
 - The outputs are measured one at a time, with one transition per measurement.
 - t_{PLZ} and t_{PHZ} are the same as t_{dis} .
 - t_{PZL} and t_{PZH} are the same as t_{en} .
 - t_{PLH} and t_{PHL} are the same as t_{pd} .
 - All parameters and waveforms are not applicable to all devices.

Figure 6-1. Load Circuit and Voltage Waveforms

7 Detailed Description

7.1 Overview

These quadruple 2-line to 1-line data selectors and multiplexers are designed for 1.65-V to 3.6-V V_{CC} operation.

The SNx4LVC257A devices are designed to multiplex signals from 4-bit data sources to 4-output data lines in bus-organized systems. The 3-state outputs do not load the data lines when the output-enable (\overline{OE}) input is at a high logic level.

7.2 Functional Block Diagram

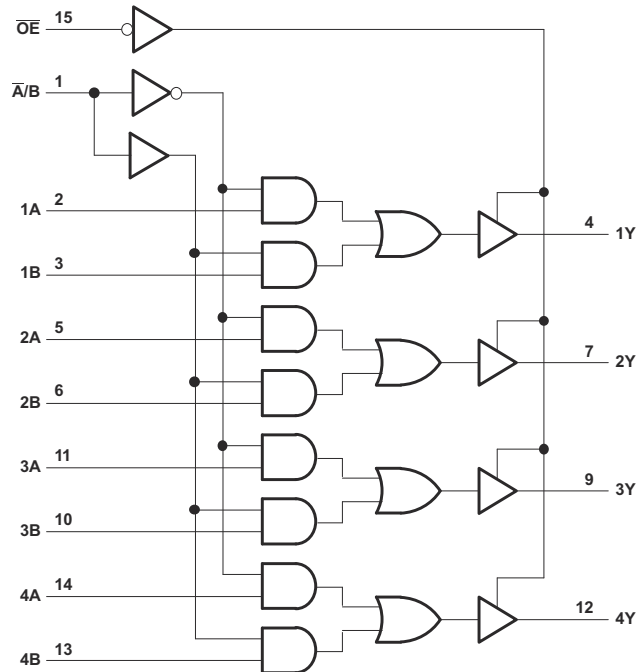

7.3 Feature Description

Inputs can be driven from either 3.3-V or 5-V devices. This feature allows the use of these devices as translators in a mixed 3.3-V and 5-V system environment. Device features a maximum t_{pd} of 4.6 ns allowing the device to be used in high-speed applications as well.

To ensure the high-impedance state during power up or power down, \overline{OE} must be tied to V_{CC} through a pullup resistor; the minimum value of the resistor is determined by the current-sinking capability of the driver.

7.4 Device Functional Modes

Table 7-1 lists the functional modes for the SN54LVC257A and SN74LVC257A devices.

Table 7-1. Function Table

INPUTS				OUTPUT Y
\overline{OE}	$\overline{A/B}$	A	B	
H	X	X	X	Z
L	L	L	X	L
L	L	H	X	H
L	H	X	L	L
L	H	X	H	H

Application and Implementation

Note

Information in the following applications sections is not part of the TI component specification, and TI does not warrant its accuracy or completeness. TI's customers are responsible for determining suitability of components for their purposes. Customers should validate and test their design implementation to confirm system functionality.

1 Application Information

The SNx4LVC257A devices are useful for digital signal data selector or multiplexer applications.

2 Typical Application

The SNx4LVC257A devices use CMOS technology and have balanced output drive. These devices can be used for down level translation and multiplexer function as shown in [Figure 8-1](#).

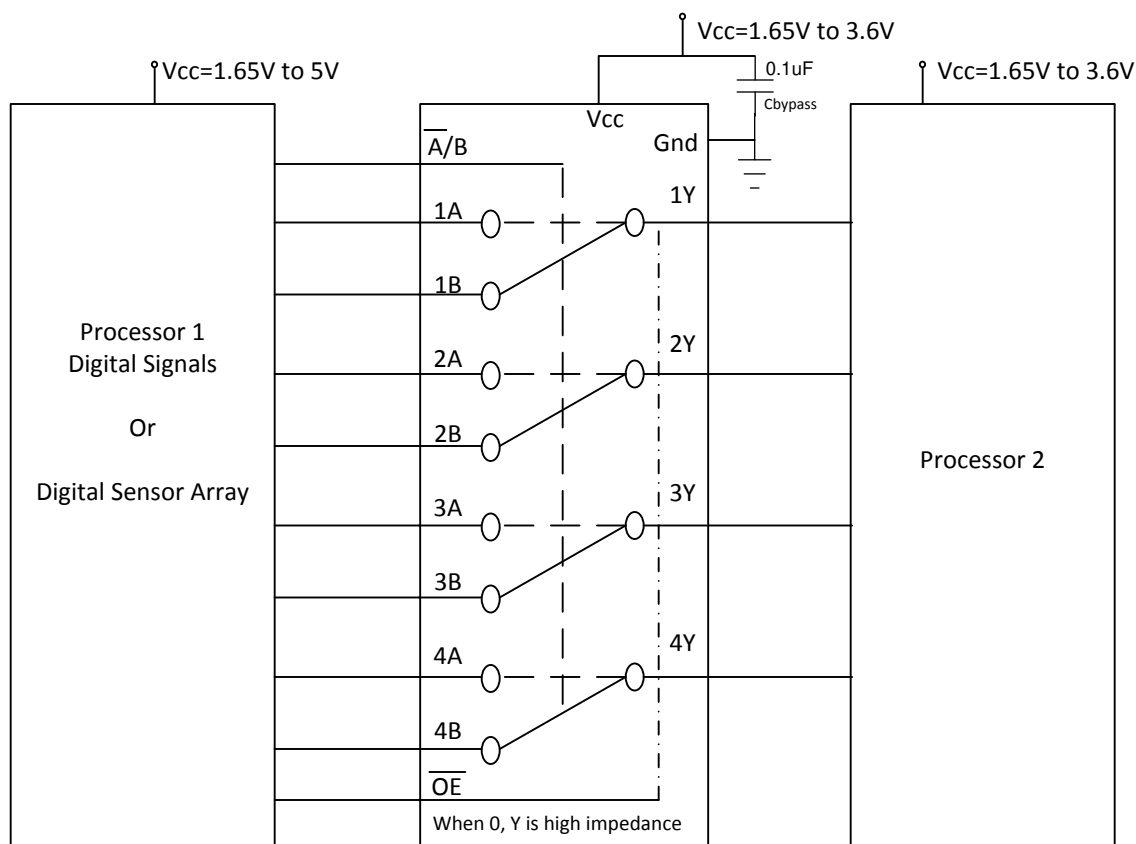

Figure 8-1. SNx4LVC257A Used as Level Translation and as a Multiplexer

2.1 Design Requirements

Take care to avoid bus contention because it can drive currents that would exceed maximum limits. The high drive will also create fast edges into light loads so routing and load conditions must be considered to prevent ringing.

2.2 Detailed Design Procedure

1. Recommended Input Conditions

- For rise time and fall time specification, see $(\Delta t/\Delta V)$ in the [Section 5.3](#) table.
- For specified high and low levels, see $(V_{IH}$ and $V_{IL})$ in the [Section 5.3](#) table.
- Inputs are over voltage tolerant allowing them to go as high as $(V_I \text{ max})$ in the [Section 5.3](#) table at any valid V_{CC} .

2. Recommend Output Conditions

- Load currents must not exceed $(I_O \text{ max})$ per output and must not exceed (continuous current through V_{CC} or GND) total current for the part. These limits are in the [Section 5.3](#) table.
- Outputs must not be pulled above V_{CC} .

2.3 Application Curves

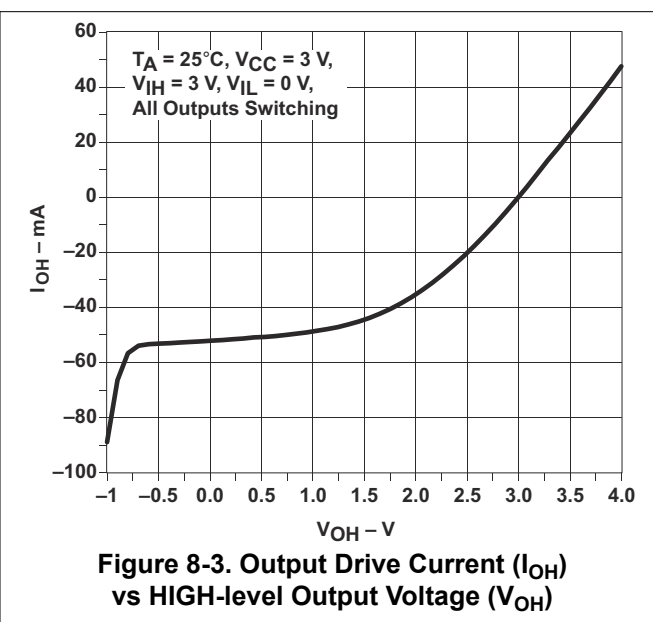
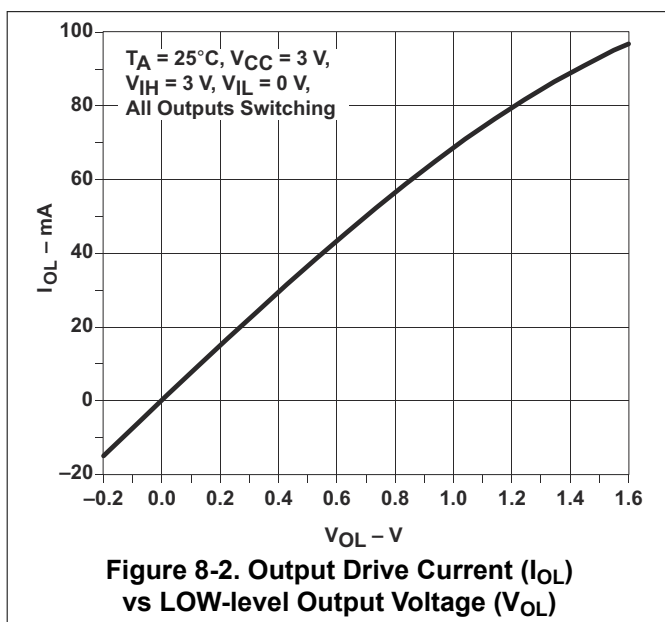

3 Power Supply Recommendations

The power supply can be any voltage between the minimum and maximum supply voltage rating located in the [Section 5.3](#) table.

Each V_{CC} terminal must have a good bypass capacitor to prevent power disturbance. For devices with a single supply, a 0.1- μF capacitor is recommended. If there are multiple V_{CC} terminals then 0.01- μF or 0.022- μF capacitors are recommended for each power terminal. It is ok to parallel multiple bypass capacitors to reject different frequencies of noise. Multiple bypass capacitors may be paralleled to reject different frequencies of noise. The bypass capacitor must be installed as close to the power terminal as possible for the best results.

4 Layout

4.1 Layout Guidelines

When using multiple bit logic devices, inputs must not float. In many cases, functions or parts of functions of digital logic devices are unused. Some examples are when only two inputs of a triple-input AND gate are used, or when only 3 of the 4-buffer gates are used. Such input pins must not be left unconnected because the undefined voltages at the outside connections result in undefined operational states.

Specified in [Figure 8-4](#) are rules that must be observed under all circumstances. All unused inputs of digital logic devices must be connected to a high or low bias to prevent them from floating. The logic level that must be applied to any particular unused input depends on the function of the device. Generally they will be tied to GND or V_{CC} , whichever makes more sense or is more convenient.

4.2 Layout Example

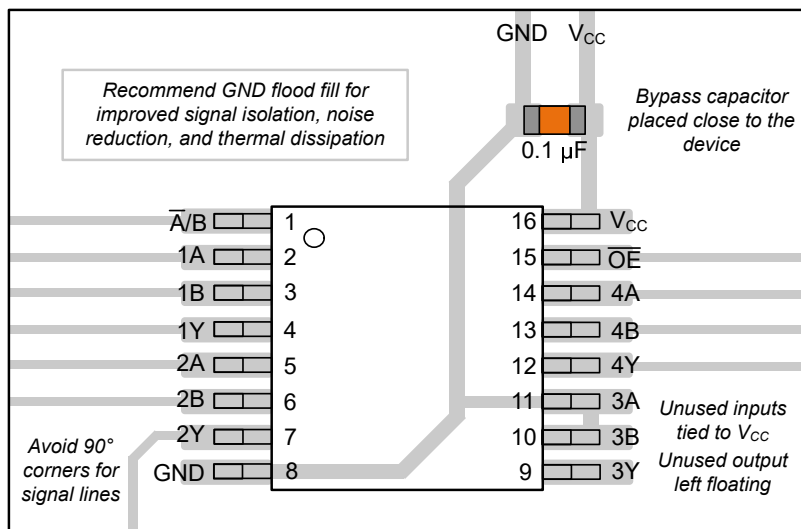

Figure 8-4. Example Layout for the SN74LVC257A

8 Device and Documentation Support

8.1 Documentation Support (Analog)

8.1.1 Related Documentation

For related documentation see the following:

Implications of Slow or Floating CMOS Inputs, [SCBA004](#)

8.1.2 Related Links

The table below lists quick access links. Categories include technical documents, support and community resources, tools and software, and quick access to sample or buy.

Table 8-1. Related Links

PARTS	PRODUCT FOLDER	SAMPLE & BUY	TECHNICAL DOCUMENTS	TOOLS & SOFTWARE	SUPPORT & COMMUNITY
SN54LVC257A	Click here	Click here	Click here	Click here	Click here
SN74LVC257A	Click here	Click here	Click here	Click here	Click here

8.2 Community Resources

8.3 Receiving Notification of Documentation Updates

To receive notification of documentation updates, navigate to the device product folder on [ti.com](#). Click on *Notifications* to register and receive a weekly digest of any product information that has changed. For change details, review the revision history included in any revised document.

8.4 Support Resources

[TI E2E™ support forums](#) are an engineer's go-to source for fast, verified answers and design help — straight from the experts. Search existing answers or ask your own question to get the quick design help you need.

Linked content is provided "AS IS" by the respective contributors. They do not constitute TI specifications and do not necessarily reflect TI's views; see TI's [Terms of Use](#).

8.5 Trademarks

TI E2E™ is a trademark of Texas Instruments.
All trademarks are the property of their respective owners.

8.6 Electrostatic Discharge Caution



This integrated circuit can be damaged by ESD. Texas Instruments recommends that all integrated circuits be handled with appropriate precautions. Failure to observe proper handling and installation procedures can cause damage.

ESD damage can range from subtle performance degradation to complete device failure. Precision integrated circuits may be more susceptible to damage because very small parametric changes could cause the device not to meet its published specifications.

8.7 Glossary

[TI Glossary](#) This glossary lists and explains terms, acronyms, and definitions.

9 Revision History

NOTE: Page numbers for previous revisions may differ from page numbers in the current version.

Changes from Revision O (June 2015) to Revision P (May 2024)	Page
• Added BQA package to <i>Package Information</i> table, <i>Pin Configuration and Functions</i> section, and <i>Thermal Information</i> table.....	1
• Added package size to <i>Device Information</i> table and deleted <i>Device Options</i> table.....	1

10 Mechanical, Packaging, and Orderable Information

The following pages include mechanical, packaging, and orderable information. This information is the most current data available for the designated devices. This data is subject to change without notice and revision of this document. For browser-based versions of this data sheet, refer to the left-hand navigation.

PACKAGING INFORMATION

Orderable Device	Status (1)	Package Type	Package Drawing	Pins	Package Qty	Eco Plan (2)	Lead finish/ Ball material (6)	MSL Peak Temp (3)	Op Temp (°C)	Device Marking (4/5)	Samples
5962-0050901QFA	ACTIVE	CFP	W	16	25	Non-RoHS & Green	SNPB	N / A for Pkg Type	-55 to 125	5962-0050901QF A SNJ54LVC257AW	Samples
SN74LVC257ABQBR	ACTIVE	WQFN	BQB	16	3000	RoHS & Green	NIPDAU	Level-1-260C-UNLIM	-40 to 125	LC257A	Samples
SN74LVC257AD	ACTIVE	SOIC	D	16	40	RoHS & Green	NIPDAU	Level-1-260C-UNLIM	-40 to 85	LVC257A	Samples
SN74LVC257ADBR	ACTIVE	SSOP	DB	16	2000	RoHS & Green	NIPDAU	Level-1-260C-UNLIM	-40 to 85	LC257A	Samples
SN74LVC257ADR	ACTIVE	SOIC	D	16	2500	RoHS & Green	NIPDAU	Level-1-260C-UNLIM	-40 to 85	LVC257A	Samples
SN74LVC257ADRG4	ACTIVE	SOIC	D	16	2500	RoHS & Green	NIPDAU	Level-1-260C-UNLIM	-40 to 85	LVC257A	Samples
SN74LVC257ANSR	ACTIVE	SO	NS	16	2000	RoHS & Green	NIPDAU	Level-1-260C-UNLIM	-40 to 85	LVC257A	Samples
SN74LVC257APW	ACTIVE	TSSOP	PW	16	90	RoHS & Green	NIPDAU	Level-1-260C-UNLIM	-40 to 85	LC257A	Samples
SN74LVC257APWR	ACTIVE	TSSOP	PW	16	2000	RoHS & Green	NIPDAU SN	Level-1-260C-UNLIM	-40 to 85	LC257A	Samples
SN74LVC257APWRG4	ACTIVE	TSSOP	PW	16	2000	RoHS & Green	NIPDAU	Level-1-260C-UNLIM	-40 to 85	LC257A	Samples
SN74LVC257APWT	ACTIVE	TSSOP	PW	16	250	RoHS & Green	NIPDAU	Level-1-260C-UNLIM	-40 to 85	LC257A	Samples
SN74LVC257ARGYR	ACTIVE	VQFN	RGY	16	3000	RoHS & Green	NIPDAU	Level-2-260C-1 YEAR	-40 to 85	LC257A	Samples
SNJ54LVC257AW	ACTIVE	CFP	W	16	25	Non-RoHS & Green	SNPB	N / A for Pkg Type	-55 to 125	5962-0050901QF A SNJ54LVC257AW	Samples

(1) The marketing status values are defined as follows:

ACTIVE: Product device recommended for new designs.

LIFEBUY: TI has announced that the device will be discontinued, and a lifetime-buy period is in effect.

NRND: Not recommended for new designs. Device is in production to support existing customers, but TI does not recommend using this part in a new design.

PREVIEW: Device has been announced but is not in production. Samples may or may not be available.

OBSOLETE: TI has discontinued the production of the device.

(2) **RoHS:** TI defines "RoHS" to mean semiconductor products that are compliant with the current EU RoHS requirements for all 10 RoHS substances, including the requirement that RoHS substance do not exceed 0.1% by weight in homogeneous materials. Where designed to be soldered at high temperatures, "RoHS" products are suitable for use in specified lead-free processes. TI may reference these types of products as "Pb-Free".

RoHS Exempt: TI defines "RoHS Exempt" to mean products that contain lead but are compliant with EU RoHS pursuant to a specific EU RoHS exemption.

Green: TI defines "Green" to mean the content of Chlorine (Cl) and Bromine (Br) based flame retardants meet JS709B low halogen requirements of <=1000ppm threshold. Antimony trioxide based flame retardants must also meet the <=1000ppm threshold requirement.

(3) MSL, Peak Temp. - The Moisture Sensitivity Level rating according to the JEDEC industry standard classifications, and peak solder temperature.

(4) There may be additional marking, which relates to the logo, the lot trace code information, or the environmental category on the device.

(5) Multiple Device Markings will be inside parentheses. Only one Device Marking contained in parentheses and separated by a "~" will appear on a device. If a line is indented then it is a continuation of the previous line and the two combined represent the entire Device Marking for that device.

(6) Lead finish/Ball material - Orderable Devices may have multiple material finish options. Finish options are separated by a vertical ruled line. Lead finish/Ball material values may wrap to two lines if the finish value exceeds the maximum column width.

Important Information and Disclaimer:The information provided on this page represents TI's knowledge and belief as of the date that it is provided. TI bases its knowledge and belief on information provided by third parties, and makes no representation or warranty as to the accuracy of such information. Efforts are underway to better integrate information from third parties. TI has taken and continues to take reasonable steps to provide representative and accurate information but may not have conducted destructive testing or chemical analysis on incoming materials and chemicals. TI and TI suppliers consider certain information to be proprietary, and thus CAS numbers and other limited information may not be available for release.

In no event shall TI's liability arising out of such information exceed the total purchase price of the TI part(s) at issue in this document sold by TI to Customer on an annual basis.

OTHER QUALIFIED VERSIONS OF SN54LVC257A, SN74LVC257A :

- Catalog : [SN74LVC257A](#)
- Automotive : [SN74LVC257A-Q1](#), [SN74LVC257A-Q1](#)
- Enhanced Product : [SN74LVC257A-EP](#), [SN74LVC257A-EP](#)
- Military : [SN54LVC257A](#)

NOTE: Qualified Version Definitions:

- Catalog - TI's standard catalog product
- Automotive - Q100 devices qualified for high-reliability automotive applications targeting zero defects
- Enhanced Product - Supports Defense, Aerospace and Medical Applications

- Military - QML certified for Military and Defense Applications

TAPE AND REEL INFORMATION



QUADRANT ASSIGNMENTS FOR PIN 1 ORIENTATION IN TAPE



*All dimensions are nominal

Device	Package Type	Package Drawing	Pins	SPQ	Reel Diameter (mm)	Reel Width W1 (mm)	A0 (mm)	B0 (mm)	K0 (mm)	P1 (mm)	W (mm)	Pin1 Quadrant
SN74LVC257ADBR	SSOP	DB	16	2000	330.0	16.4	8.35	6.6	2.4	12.0	16.0	Q1
SN74LVC257ADR	SOIC	D	16	2500	330.0	16.4	6.5	10.3	2.1	8.0	16.0	Q1
SN74LVC257ANSR	SO	NS	16	2000	330.0	16.4	8.2	10.5	2.5	12.0	16.0	Q1
SN74LVC257APWR	TSSOP	PW	16	2000	330.0	12.4	6.9	5.6	1.6	8.0	12.0	Q1
SN74LVC257APWRG4	TSSOP	PW	16	2000	330.0	12.4	6.9	5.6	1.6	8.0	12.0	Q1
SN74LVC257APWT	TSSOP	PW	16	250	330.0	12.4	6.9	5.6	1.6	8.0	12.0	Q1
SN74LVC257ARGYR	VQFN	RGY	16	3000	330.0	12.4	3.8	4.3	1.5	8.0	12.0	Q1

TAPE AND REEL BOX DIMENSIONS

*All dimensions are nominal

Device	Package Type	Package Drawing	Pins	SPQ	Length (mm)	Width (mm)	Height (mm)
SN74LVC257ADBR	SSOP	DB	16	2000	356.0	356.0	35.0
SN74LVC257ADR	SOIC	D	16	2500	340.5	336.1	32.0
SN74LVC257ANSR	SO	NS	16	2000	356.0	356.0	35.0
SN74LVC257APWR	TSSOP	PW	16	2000	356.0	356.0	35.0
SN74LVC257APWRG4	TSSOP	PW	16	2000	356.0	356.0	35.0
SN74LVC257APWT	TSSOP	PW	16	250	356.0	356.0	35.0
SN74LVC257ARGYR	VQFN	RGY	16	3000	356.0	356.0	35.0

TUBE

*All dimensions are nominal

Device	Package Name	Package Type	Pins	SPQ	L (mm)	W (mm)	T (μm)	B (mm)
5962-0050901QFA	W	CFP	16	25	506.98	26.16	6220	NA
SN74LVC257AD	D	SOIC	16	40	507	8	3940	4.32
SN74LVC257APW	PW	TSSOP	16	90	530	10.2	3600	3.5
SNJ54LVC257AW	W	CFP	16	25	506.98	26.16	6220	NA

GENERIC PACKAGE VIEW

BQB 16

WQFN - 0.8 mm max height

2.5 x 3.5, 0.5 mm pitch

PLASTIC QUAD FLATPACK - NO LEAD

This image is a representation of the package family, actual package may vary.
Refer to the product data sheet for package details.

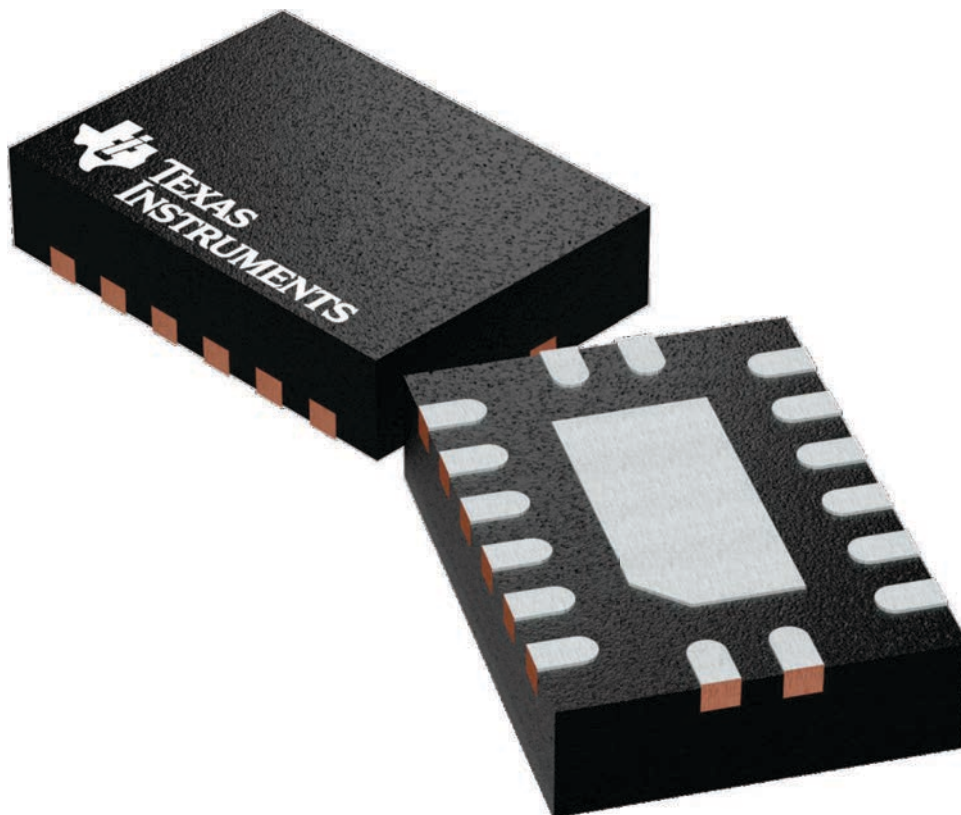

4226161/A

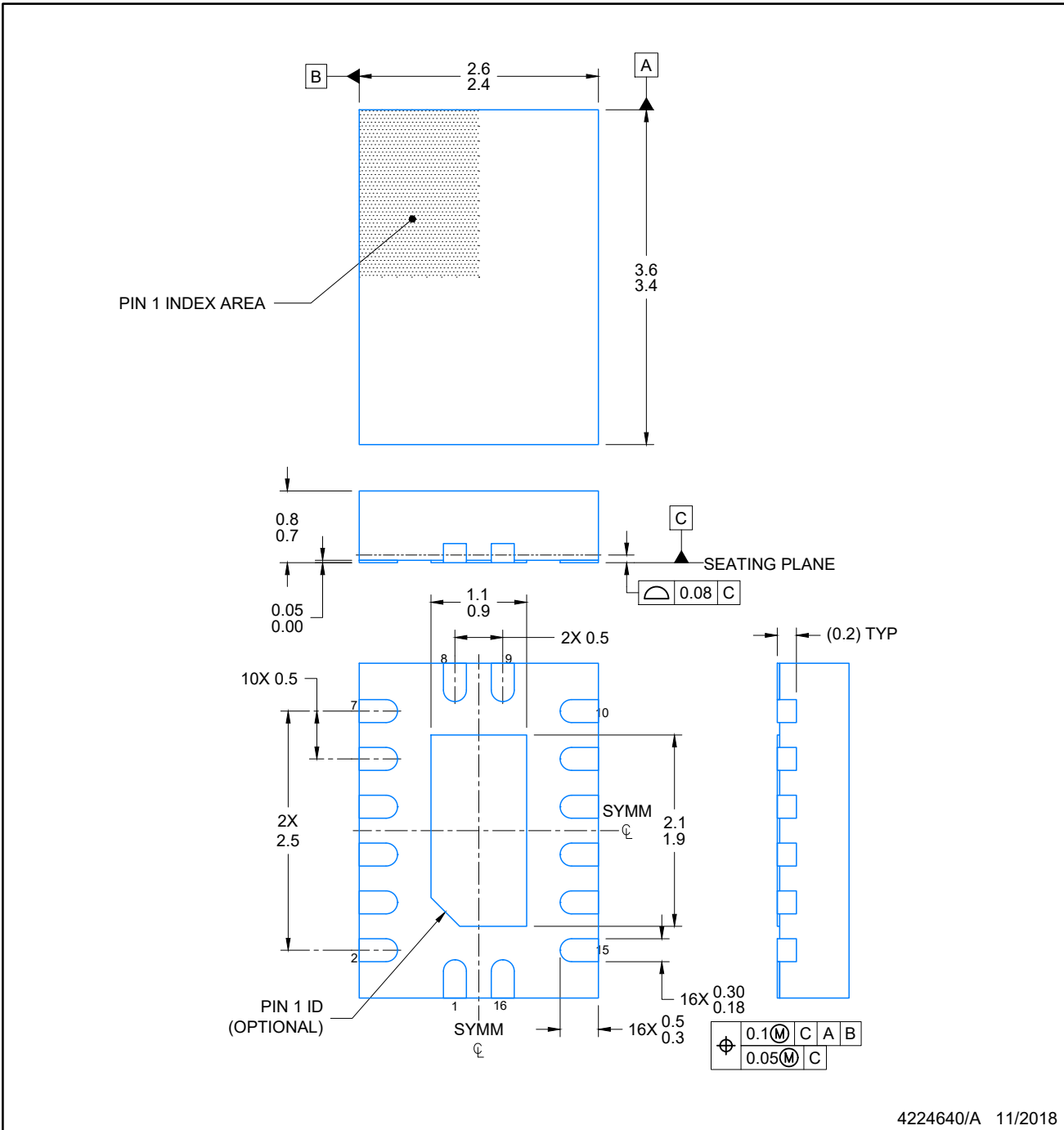

4224640/A 11/2018

NOTES:

1. All linear dimensions are in millimeters. Any dimensions in parenthesis are for reference only. Dimensioning and tolerancing per ASME Y14.5M.
2. This drawing is subject to change without notice.
3. The package thermal pad must be soldered to the printed circuit board for optimal thermal and mechanical performance.

EXAMPLE STENCIL DESIGN

BQB0016A

WQFN - 0.8 mm max height

PLASTIC QUAD FLAT PACK-NO LEAD

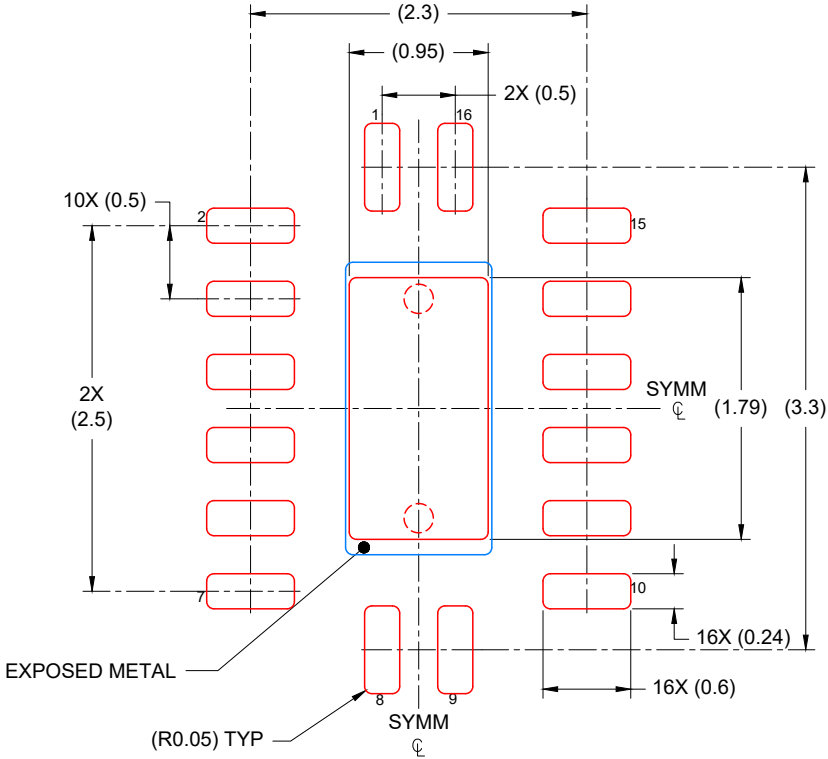

SOLDER PASTE EXAMPLE
 BASED ON 0.125 mm THICK STENCIL

EXPOSED PAD
 85% PRINTED COVERAGE BY AREA
 SCALE: 20X

4224640/A 11/2018

NOTES: (continued)

- 6. Laser cutting apertures with trapezoidal walls and rounded corners may offer better paste release. IPC-7525 may have alternate design recommendations.

W (R-GDFP-F16)

CERAMIC DUAL FLATPACK

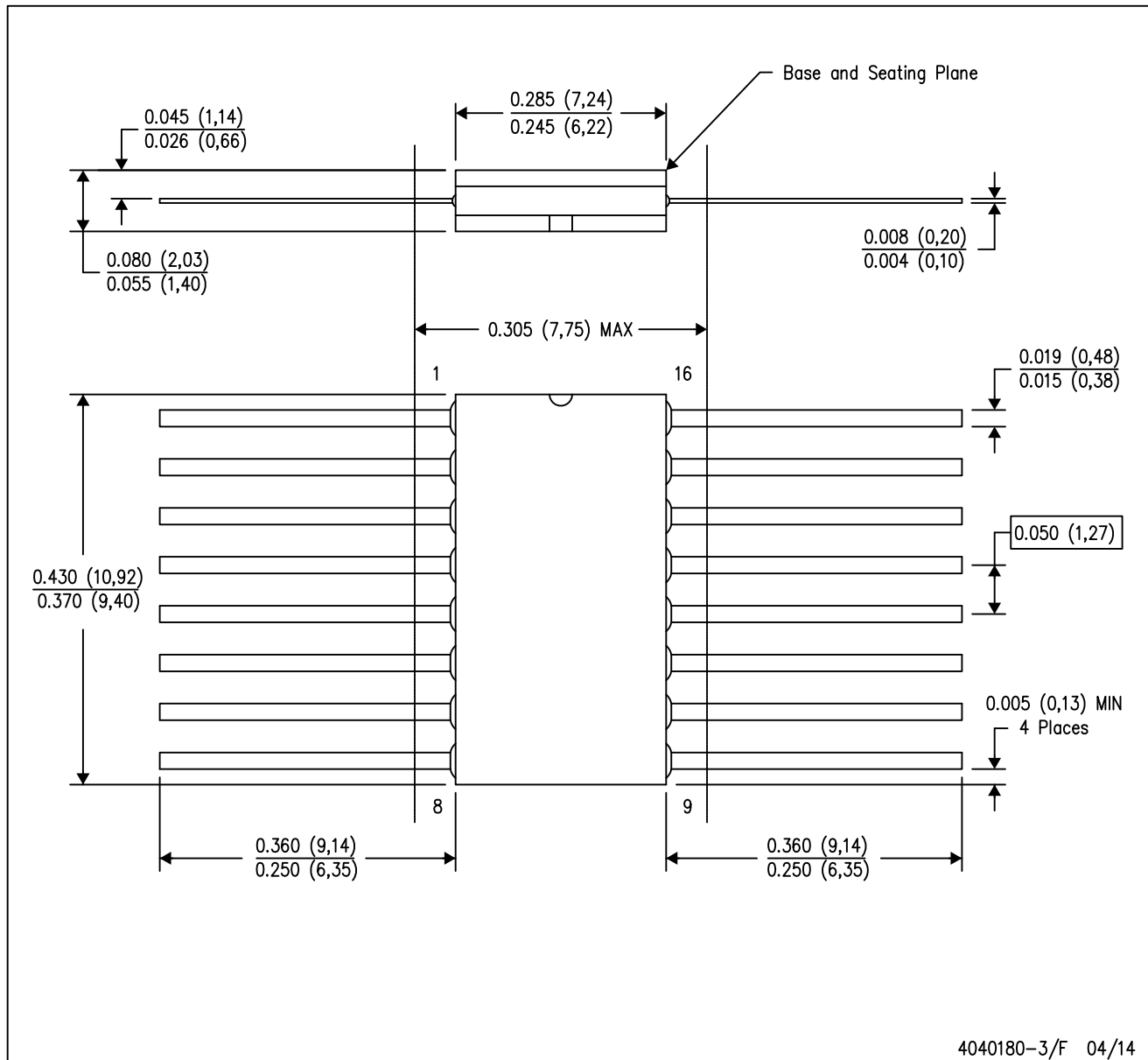

- NOTES:
- A. All linear dimensions are in inches (millimeters).
 - B. This drawing is subject to change without notice.
 - C. This package can be hermetically sealed with a ceramic lid using glass frit.
 - D. Index point is provided on cap for terminal identification only.
 - E. Falls within MIL STD 1835 GDFP2-F16

RGY (R-PVQFN-N16)

PLASTIC QUAD FLATPACK NO-LEAD



4203539-3/1 06/2011

- NOTES:
- All linear dimensions are in millimeters. Dimensioning and tolerancing per ASME Y14.5M-1994.
 - This drawing is subject to change without notice.
 - QFN (Quad Flatpack No-Lead) package configuration.
 - The package thermal pad must be soldered to the board for thermal and mechanical performance.
 - See the additional figure in the Product Data Sheet for details regarding the exposed thermal pad features and dimensions.
 - Pin 1 identifiers are located on both top and bottom of the package and within the zone indicated. The Pin 1 identifiers are either a molded, marked, or metal feature.
 - Package complies to JEDEC MO-241 variation BA.

RGY (R-PVQFN-N16)

PLASTIC QUAD FLATPACK NO-LEAD

THERMAL INFORMATION

This package incorporates an exposed thermal pad that is designed to be attached directly to an external heatsink. The thermal pad must be soldered directly to the printed circuit board (PCB). After soldering, the PCB can be used as a heatsink. In addition, through the use of thermal vias, the thermal pad can be attached directly to the appropriate copper plane shown in the electrical schematic for the device, or alternatively, can be attached to a special heatsink structure designed into the PCB. This design optimizes the heat transfer from the integrated circuit (IC).

For information on the Quad Flatpack No-Lead (QFN) package and its advantages, refer to Application Report, QFN/SON PCB Attachment, Texas Instruments Literature No. SLUA271. This document is available at www.ti.com.

The exposed thermal pad dimensions for this package are shown in the following illustration.



Bottom View

Exposed Thermal Pad Dimensions

4206353-3/P 03/14

NOTE: All linear dimensions are in millimeters

RGY (R-PVQFN-N16)

PLASTIC QUAD FLATPACK NO-LEAD



- NOTES:
- A. All linear dimensions are in millimeters.
 - B. This drawing is subject to change without notice.
 - C. Publication IPC-7351 is recommended for alternate designs.
 - D. This package is designed to be soldered to a thermal pad on the board. Refer to Application Note, Quad Flat-Pack QFN/SON PCB Attachment, Texas Instruments Literature No. SLUA271, and also the Product Data Sheets for specific thermal information, via requirements, and recommended board layout. These documents are available at www.ti.com <<http://www.ti.com>>.
 - E. Laser cutting apertures with trapezoidal walls and also rounding corners will offer better paste release. Customers should contact their board assembly site for stencil design recommendations. Refer to IPC 7525 for stencil design considerations.
 - F. Customers should contact their board fabrication site for minimum solder mask web tolerances between signal pads.



PACKAGE OUTLINE

NS0016A

SOP - 2.00 mm max height

SOP

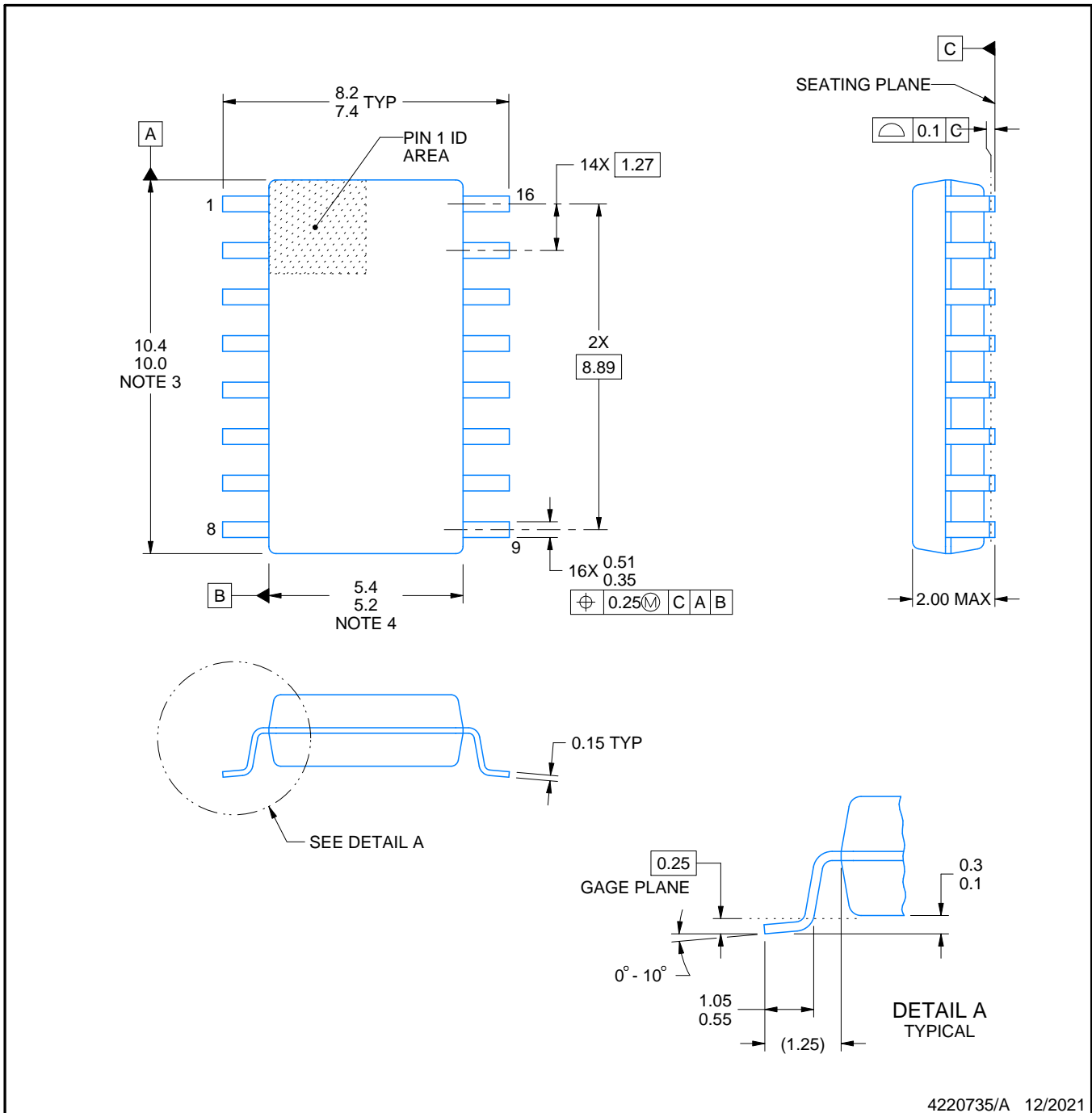

4220735/A 12/2021

NOTES:

1. All linear dimensions are in millimeters. Dimensions in parenthesis are for reference only. Dimensioning and tolerancing per ASME Y14.5M.
2. This drawing is subject to change without notice.
3. This dimension does not include mold flash, protrusions, or gate burrs. Mold flash, protrusions, or gate burrs shall not exceed 0.15 mm, per side.
4. This dimension does not include interlead flash. Interlead flash shall not exceed 0.25 mm, per side.

EXAMPLE BOARD LAYOUT

NS0016A

SOP - 2.00 mm max height

SOP



4220735/A 12/2021

NOTES: (continued)

5. Publication IPC-7351 may have alternate designs.

6. Solder mask tolerances between and around signal pads can vary based on board fabrication site.

EXAMPLE STENCIL DESIGN

NS0016A

SOP - 2.00 mm max height

SOP

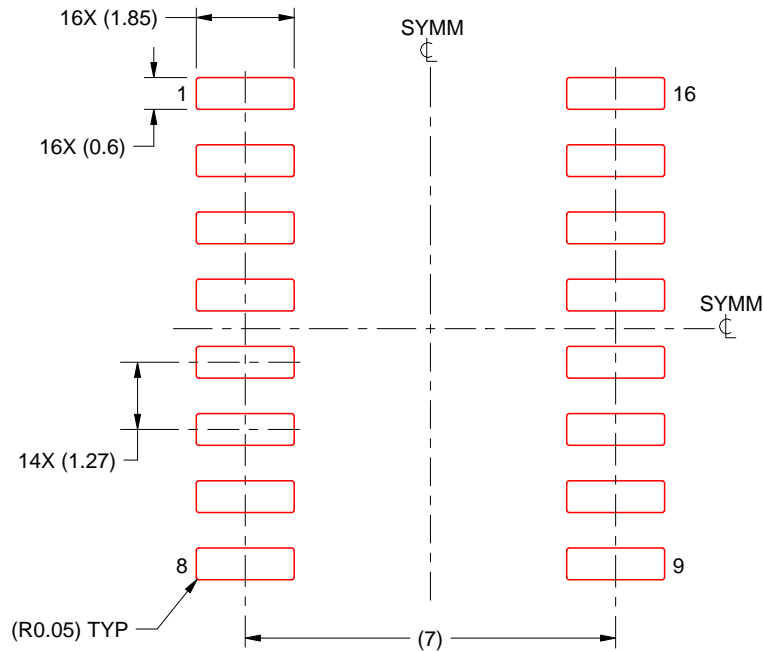

SOLDER PASTE EXAMPLE
BASED ON 0.125 mm THICK STENCIL
SCALE:7X

4220735/A 12/2021

NOTES: (continued)

7. Laser cutting apertures with trapezoidal walls and rounded corners may offer better paste release. IPC-7525 may have alternate design recommendations.
8. Board assembly site may have different recommendations for stencil design.

D (R-PDSO-G16)

PLASTIC SMALL OUTLINE

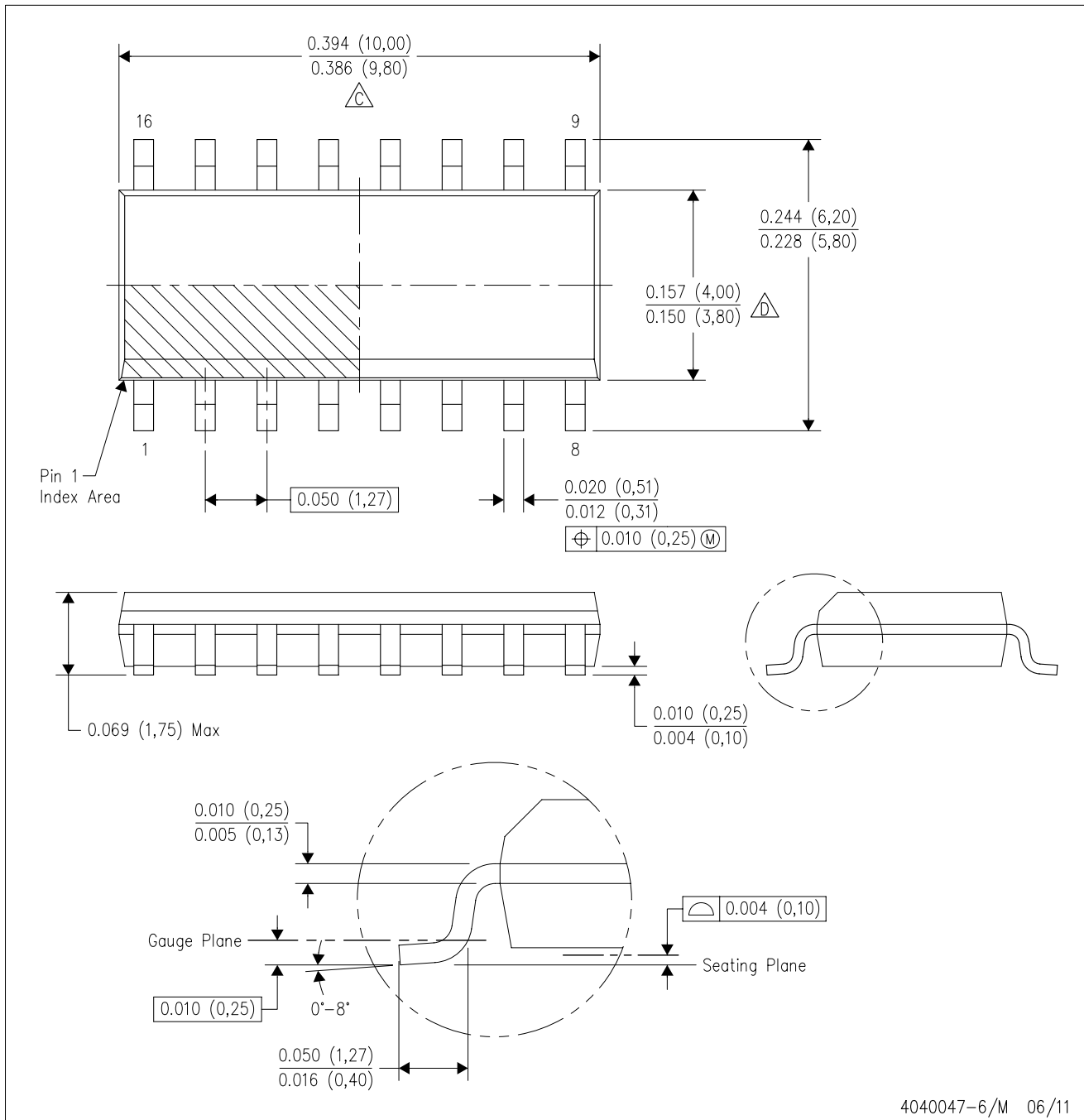

- NOTES:
- A. All linear dimensions are in inches (millimeters).
 - B. This drawing is subject to change without notice.
 - C. Body length does not include mold flash, protrusions, or gate burrs. Mold flash, protrusions, or gate burrs shall not exceed 0.006 (0,15) each side.
 - D. Body width does not include interlead flash. Interlead flash shall not exceed 0.017 (0,43) each side.
 - E. Reference JEDEC MS-012 variation AC.



4220204/A 02/2017

NOTES:

1. All linear dimensions are in millimeters. Any dimensions in parenthesis are for reference only. Dimensioning and tolerancing per ASME Y14.5M.
2. This drawing is subject to change without notice.
3. This dimension does not include mold flash, protrusions, or gate burrs. Mold flash, protrusions, or gate burrs shall not exceed 0.15 mm per side.
4. This dimension does not include interlead flash. Interlead flash shall not exceed 0.25 mm per side.
5. Reference JEDEC registration MO-153.

EXAMPLE BOARD LAYOUT

PW0016A

TSSOP - 1.2 mm max height

SMALL OUTLINE PACKAGE



LAND PATTERN EXAMPLE
EXPOSED METAL SHOWN
SCALE: 10X



SOLDER MASK DETAILS

4220204/A 02/2017

NOTES: (continued)

- 6. Publication IPC-7351 may have alternate designs.
- 7. Solder mask tolerances between and around signal pads can vary based on board fabrication site.

EXAMPLE STENCIL DESIGN

PW0016A

TSSOP - 1.2 mm max height

SMALL OUTLINE PACKAGE



SOLDER PASTE EXAMPLE
BASED ON 0.125 mm THICK STENCIL
SCALE: 10X

4220204/A 02/2017

NOTES: (continued)

8. Laser cutting apertures with trapezoidal walls and rounded corners may offer better paste release. IPC-7525 may have alternate design recommendations.
9. Board assembly site may have different recommendations for stencil design.

DB0016A



PACKAGE OUTLINE

SSOP - 2 mm max height

SMALL OUTLINE PACKAGE

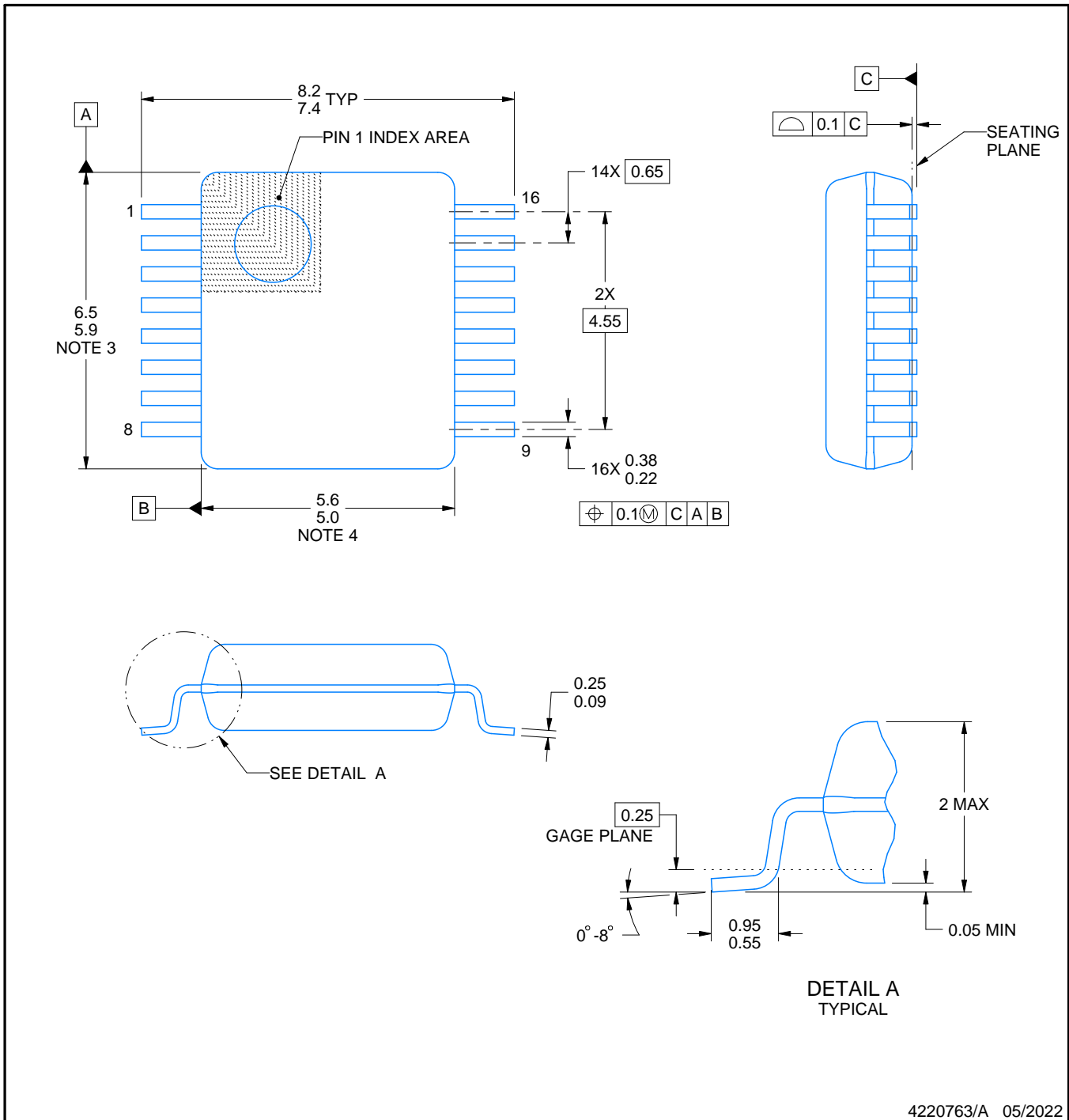

4220763/A 05/2022

NOTES:

1. All linear dimensions are in millimeters. Any dimensions in parenthesis are for reference only. Dimensioning and tolerancing per ASME Y14.5M.
2. This drawing is subject to change without notice.
3. This dimension does not include mold flash, protrusions, or gate burrs. Mold flash, protrusions, or gate burrs shall not exceed 0.15 mm per side.
4. Reference JEDEC registration MO-150.

EXAMPLE BOARD LAYOUT

DB0016A

SSOP - 2 mm max height

SMALL OUTLINE PACKAGE

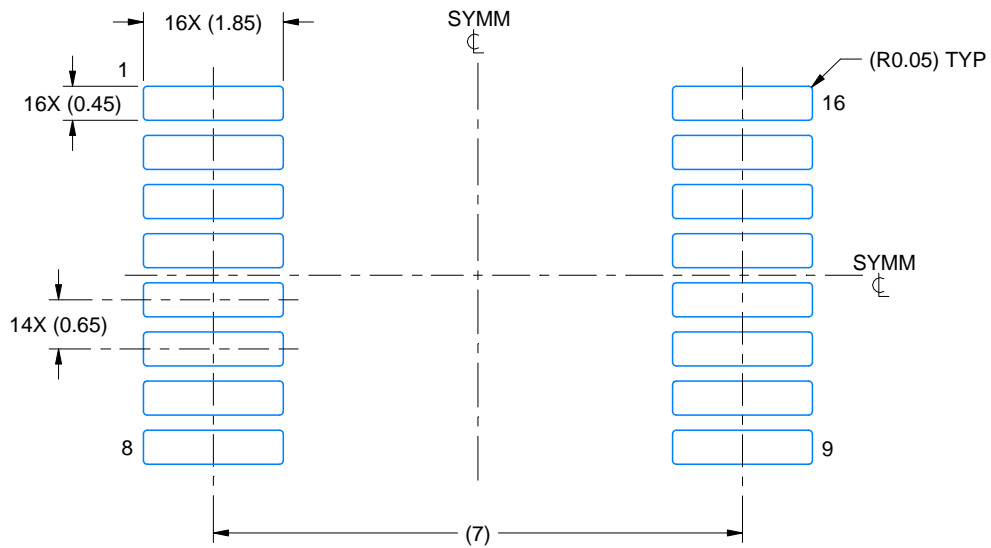

LAND PATTERN EXAMPLE
EXPOSED METAL SHOWN
SCALE: 10X

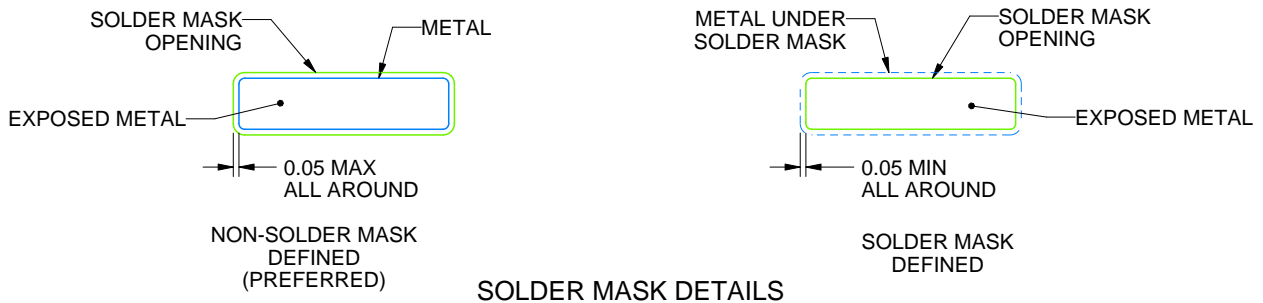

4220763/A 05/2022

NOTES: (continued)

- 5. Publication IPC-7351 may have alternate designs.
- 6. Solder mask tolerances between and around signal pads can vary based on board fabrication site.

EXAMPLE STENCIL DESIGN

DB0016A

SSOP - 2 mm max height

SMALL OUTLINE PACKAGE

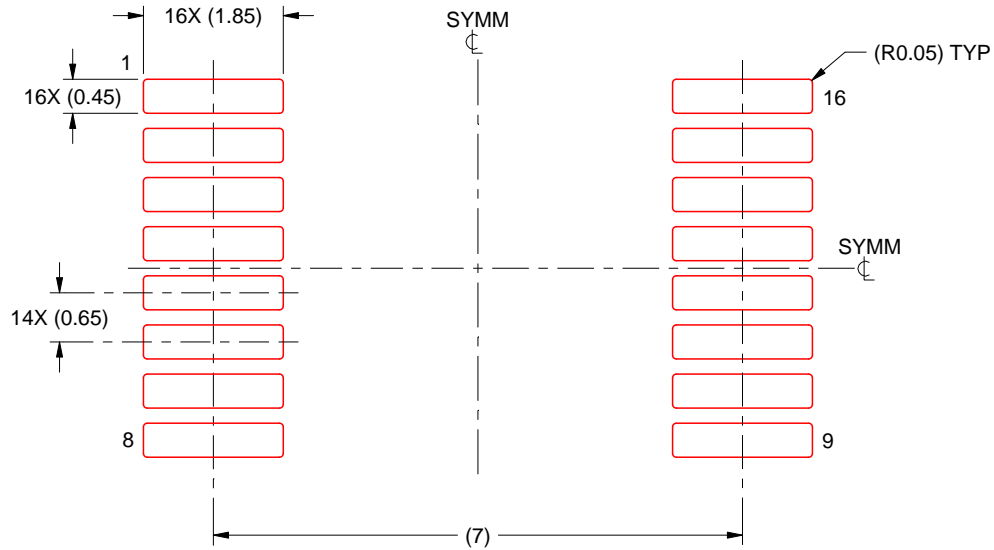

SOLDER PASTE EXAMPLE
BASED ON 0.125 mm THICK STENCIL
SCALE: 10X

4220763/A 05/2022

NOTES: (continued)

7. Laser cutting apertures with trapezoidal walls and rounded corners may offer better paste release. IPC-7525 may have alternate design recommendations.
8. Board assembly site may have different recommendations for stencil design.

MECHANICAL DATA

NS (R-PDSO-G**)

PLASTIC SMALL-OUTLINE PACKAGE

14-PINS SHOWN



- NOTES:
- A. All linear dimensions are in millimeters.
 - B. This drawing is subject to change without notice.
 - C. Body dimensions do not include mold flash or protrusion, not to exceed 0,15.

IMPORTANT NOTICE AND DISCLAIMER

TI PROVIDES TECHNICAL AND RELIABILITY DATA (INCLUDING DATA SHEETS), DESIGN RESOURCES (INCLUDING REFERENCE DESIGNS), APPLICATION OR OTHER DESIGN ADVICE, WEB TOOLS, SAFETY INFORMATION, AND OTHER RESOURCES "AS IS" AND WITH ALL FAULTS, AND DISCLAIMS ALL WARRANTIES, EXPRESS AND IMPLIED, INCLUDING WITHOUT LIMITATION ANY IMPLIED WARRANTIES OF MERCHANTABILITY, FITNESS FOR A PARTICULAR PURPOSE OR NON-INFRINGEMENT OF THIRD PARTY INTELLECTUAL PROPERTY RIGHTS.

These resources are intended for skilled developers designing with TI products. You are solely responsible for (1) selecting the appropriate TI products for your application, (2) designing, validating and testing your application, and (3) ensuring your application meets applicable standards, and any other safety, security, regulatory or other requirements.

These resources are subject to change without notice. TI grants you permission to use these resources only for development of an application that uses the TI products described in the resource. Other reproduction and display of these resources is prohibited. No license is granted to any other TI intellectual property right or to any third party intellectual property right. TI disclaims responsibility for, and you will fully indemnify TI and its representatives against, any claims, damages, costs, losses, and liabilities arising out of your use of these resources.

TI's products are provided subject to [TI's Terms of Sale](#) or other applicable terms available either on [ti.com](https://www.ti.com) or provided in conjunction with such TI products. TI's provision of these resources does not expand or otherwise alter TI's applicable warranties or warranty disclaimers for TI products.

TI objects to and rejects any additional or different terms you may have proposed.

Mailing Address: Texas Instruments, Post Office Box 655303, Dallas, Texas 75265
Copyright © 2024, Texas Instruments Incorporated

Looking for pricing, stock, or lifecycle information?

Click below to explore more details on WIN SOURCE:

 [View SN74LVC257APWRG4 on WIN SOURCE](#)

 [Texas Instruments](#) Information

Optimize Your Supply Chain with WIN SOURCE Solutions

-  Global Sourcing Solution
-  Obsolete Management
-  Cost Control Management
-  Shortage Management
-  Alternative Solution
-  Excess Inventory Management