



**THE DATASHEET OF
SN74AHCT595PW**



SNx4AHCT595 8-Bit Shift Registers With 3-State Output Registers

1 Features

- Inputs are TTL-voltage compatible
- 8-bit serial-in, parallel-out shift
- Shift register has direct clear
- Latch-up performance exceeds 100mA per JESD 78, Class II
- ESD protection exceeds JESD 22:
 - 2000V Human-Body Model (A114-A)
 - 200V Machine Model (A115-A)
 - 1000V Charged-Device Model (C101)

2 Applications

- Network switches
- Power infrastructures
- [PCs and notebooks](#)
- [LED displays](#)
- [Servers](#)

3 Description

The SNx4AHCT595 devices contain an 8-bit serial-in, parallel-out shift register that feeds an 8-bit D-type storage register. Both the shift register clock (SRCLK) and storage register clock (RCLK) are positive-edge triggered.

Package Information

PART NUMBER	PACKAGE ⁽¹⁾	PACKAGE SIZE ⁽²⁾	BODY SIZE (NOM) ⁽³⁾
SNx4AHCT595	BQB (WQFN, 16)	3.5mm × 2.5mm	3.5mm × 2.5mm
	PW (TSSOP, 16)	5.0mm × 6.4mm	5.0mm × 4.4mm

- (1) For more information, see [Section 11](#).
- (2) The package size (length × width) is a nominal value and includes pins, where applicable.
- (3) The body size (length × width) is a nominal value and does not include pins.

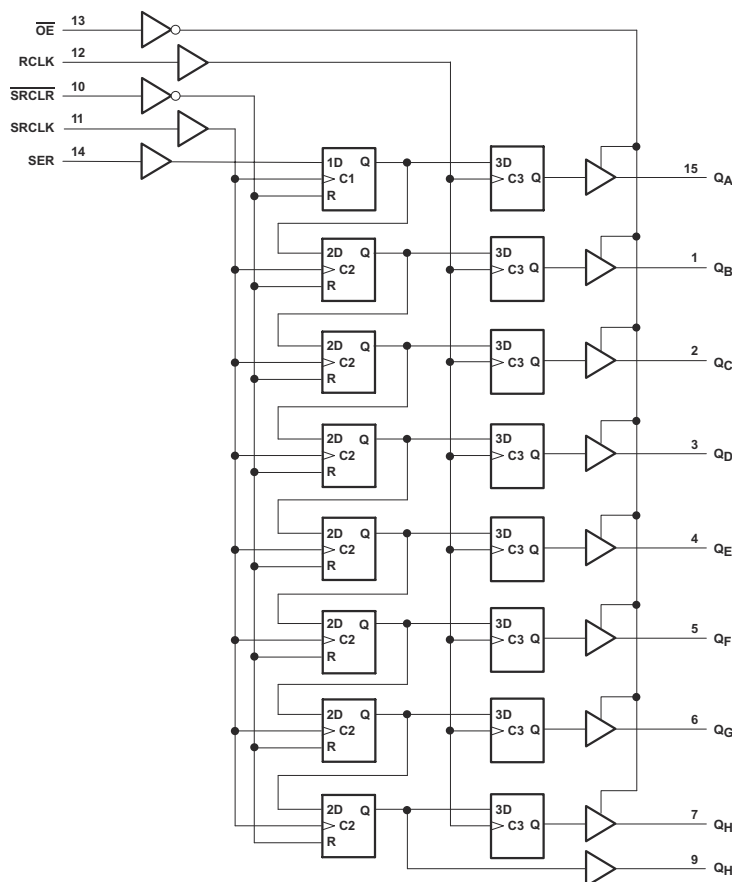

Pin numbers shown are for the D, DB, J, N, NS, PW, and W packages.

Simplified Schematic

Table of Contents

1 Features	1	7.2 Functional Block Diagram.....	9
2 Applications	1	7.3 Feature Description.....	10
3 Description	1	7.4 Device Functional Modes.....	10
4 Pin Configuration and Functions	3	8 Application and Implementation	11
5 Specifications	4	8.1 Application Information.....	11
5.1 Absolute Maximum Ratings.....	4	8.2 Typical Application.....	11
5.2 Handling Ratings.....	4	8.3 Power Supply Recommendations.....	12
5.3 Recommended Operating Conditions.....	4	8.4 Layout.....	12
5.4 Thermal Information.....	5	9 Device and Documentation Support	14
5.5 Electrical Characteristics.....	5	9.1 Receiving Notification of Documentation Updates....	14
5.6 Timing Requirements.....	5	9.2 Support Resources.....	14
5.7 Switching Characteristics.....	6	9.3 Trademarks.....	14
5.8 Noise Characteristics.....	7	9.4 Electrostatic Discharge Caution.....	14
5.9 Operating Characteristics.....	7	9.5 Glossary.....	14
5.10 Typical Characteristics.....	7	10 Revision History	14
6 Parameter Measurement Information	8	11 Mechanical, Packaging, and Orderable Information	14
7 Detailed Description	9		
7.1 Overview.....	9		

4 Pin Configuration and Functions

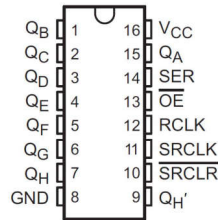

Figure 4-1.
SN74AHCT595-Q1 PW Package (Top View)

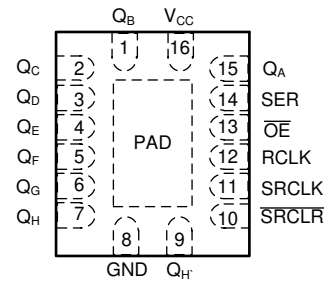
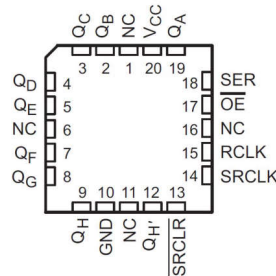

Figure 4-2. BQB Package, 16-Pin WQFN (Top View)



NC – No internal connection

Figure 4-3. SN74AHCT595-Q1 BQB Package (Top View)

Table 4-1. Pin Functions

NAME	PIN		TYPE ⁽¹⁾	DESCRIPTION
	SN74AHCT595 PW	BQB		
GND	8	8	—	Ground Pin
\overline{OE}	13	13	I	Output Enable
Q _A	15	15	O	Q _A Output
Q _B	1	1	O	Q _B Output
Q _C	2	2	O	Q _C Output
Q _D	3	3	O	Q _D Output
Q _E	4	4	O	Q _E Output
Q _F	5	5	O	Q _F Output
Q _G	6	6	O	Q _G Output
Q _H	7	7	O	Q _H Output
Q _{H'}	9	9	O	Q _{H'} Output
RCLK	12	12	I	RCLK Input
SER	14	14	I	SER Input
SRCLK	11	11	I	SRCLK Input
\overline{SRCLR}	10	10	I	\overline{SRCLR} Input
NC	—	—	—	No Connection
V _{CC}	16	16	—	Power Pin

(1) I = input, O = output

5 Specifications

5.1 Absolute Maximum Ratings

over operating free-air temperature range (unless otherwise noted)⁽¹⁾

		MIN	MAX	UNIT	
V _{CC}	Supply voltage range	-0.5	7	V	
V _I	Input voltage range ⁽²⁾	-0.5	7	V	
V _O	Output voltage range ⁽²⁾	-0.5	V _{CC} + 0.5	V	
I _{IK}	Input clamp current	V _I < 0		-20	mA
I _{OK}	Output clamp current	V _O < 0 or V _O > V _{CC}		±20	mA
I _O	Continuous output current	V _O = 0 to V _{CC}		±25	mA
Continuous current through V _{CC} or GND				±50	mA

(1) Stresses beyond those listed under *Absolute Maximum Ratings* may cause permanent damage to the device. These are stress ratings only, which do not imply functional operation of the device at these or any other conditions beyond those indicated under *Recommended Operating Conditions*. Exposure to absolute-maximum-rated conditions for extended periods may affect device reliability.

(2) The input and output voltage ratings may be exceeded if the input and output current ratings are observed.

5.2 Handling Ratings

		MIN	MAX	UNIT
T _{stg}	Storage temperature range	-65	150	°C
V _(ESD)	Electrostatic discharge	Human body model (HBM), per ANSI/ESDA/JEDEC JS-001, all pins ⁽¹⁾		V
		Charged device model (CDM), per JEDEC specification JESD22-C101, all pins ⁽²⁾		
		0	2000	
		0	1000	

(1) JEDEC document JEP155 states that 500V HBM allows safe manufacturing with a standard ESD control process.

(2) JEDEC document JEP157 states that 250V CDM allows safe manufacturing with a standard ESD control process.

5.3 Recommended Operating Conditions

over operating free-air temperature range (unless otherwise noted)⁽¹⁾

		SN54AHCT595 ⁽²⁾		SN74AHCT595		UNIT
		MIN	MAX	MIN	MAX	
V _{CC}	Supply voltage	4.5	5.5	4.5	5.5	V
V _{IH}	High-level input voltage	2		2		V
V _{IL}	Low-level input voltage		0.8		0.8	V
V _I	Input voltage	0	5.5	0	5.5	V
V _O	Output voltage	0	V _{CC}	0	V _{CC}	V
I _{OH}	High-level output current		-8		-8	mA
I _{OL}	Low-level output current		8		8	mA
Δt/Δv	Input transition rise and fall time		20		20	ns/V
T _A	Operating free-air temperature	-55	125	-40	125	°C

(1) All unused inputs of the device must be held at V_{CC} or GND for proper device operation. Refer to the TI application report, *Implications of Slow or Floating CMOS Inputs*, literature number [SCBA004](#).

(2) Product Preview

5.4 Thermal Information

THERMAL METRIC ⁽¹⁾		SN74AHCT595						UNIT
		BQB (WQFN)	D (SOIC)	DB (SSOP)	N (PDIP)	NS (SOP)	PW (TSSOP)	
		16 PINS						
R _{θJA}	Junction-to-ambient thermal resistance	91.8	80.2	97.5	47.5	126.2	135.9	°C/W
R _{θJC(top)}	Junction-to-case (top) thermal resistance	87.7	39.1	47.7	34.9	68.7	70.3	
R _{θJB}	Junction-to-board thermal resistance	61.6	27.7	48.1	27.5	77.3	81.3	
Ψ _{JT}	Junction-to-top characterization parameter	11.9	9.9	9.8	19.8	22.3	22.5	
Ψ _{JB}	Junction-to-board characterization parameter	61.4	37.4	47.6	27.4	76.9	80.8	
R _{θJC(bot)}	Junction-to-case (bottom) thermal resistance	39.4	n/a	n/a	n/a	n/a	n/a	

(1) For more information about traditional and new thermal metrics, see the *IC Package Thermal Metrics* application report, [SPRA953](#).

5.5 Electrical Characteristics

over operating free-air temperature range (unless otherwise noted)

PARAMETER	TEST CONDITIONS	V _{CC}	T _A = 25°C			SN54AHCT595 ⁽¹⁾		SN74AHCT595		UNIT
			MIN	TYP	MAX	MIN	MAX	MIN	MAX	
V _{OH}	I _{OH} = -50mA	4.5V	4.4	4.5		4.4		4.4	V	
	I _{OH} = -8mA		3.94			3.8		3.8		
V _{OL}	I _{OL} = 50μA	4.5V			0.1			0.1	V	
	I _{OL} = 8mA				0.36	0.44	0.44			
I _I	V _I = 5.5V or GND	0 to 5.5V			±0.1		±1 ⁽²⁾	±1	μA	
I _{OZ}	V _O = V _{CC} or GND	Q _A – Q _H			±0.25		±2.5	±2.5	μA	
I _{CC}	V _I = V _{CC} or GND	I _O = 0			4		40	40	μA	
ΔI _{CC} ⁽³⁾	One input at 3.4V, Other inputs at V _{CC} or GND	5.5V			2		2.2	2.2	mA	
C _i	V _I = V _{CC} or GND	5V		3	10			10	pF	
C _o	V _O = V _{CC} or GND	5V		5.5					pF	

(1) Product Preview

(2) On products compliant to MIL-PRF-38535, this parameter is not production tested at V_{CC} = 0V.

(3) This is the increase in supply current for each input at one of the specified TTL voltage levels, rather than 0V or V_{CC}.

5.6 Timing Requirements

over recommended operating free-air temperature range, V_{CC} = 5V ± 0.5V (unless otherwise noted) (see [Figure 6-1](#))

PARAMETER		T _A = 25°C		SN54AHCT595 ⁽¹⁾		SN74AHCT595		UNIT
		MIN	MAX	MIN	MAX	MIN	MAX	
t _w	Pulse duration	SRCLK high or low	5		5.5		5.5	ns
		RCLK high or low	5		5.5		5.5	
		SRCLR low	5		5		5	
t _{su}	Setup time	SER before SRCLK↑	3		3		3	ns
		SRCLK↑ before RCLK↑ ⁽²⁾	5		5		5	
		SRCLR low before RCLK↑	5		5		5	
		SRCLR high (inactive) before SRCLK↑	3.4		3.8		3.8	
t _h	Hold time	SER after SRCLK↑	2		2		2	ns

(1) Product Preview

(2) This setup time allows the storage register to receive stable data from the shift register. The clocks can be tied together, in which case the shift register is one clock pulse ahead of the storage register.

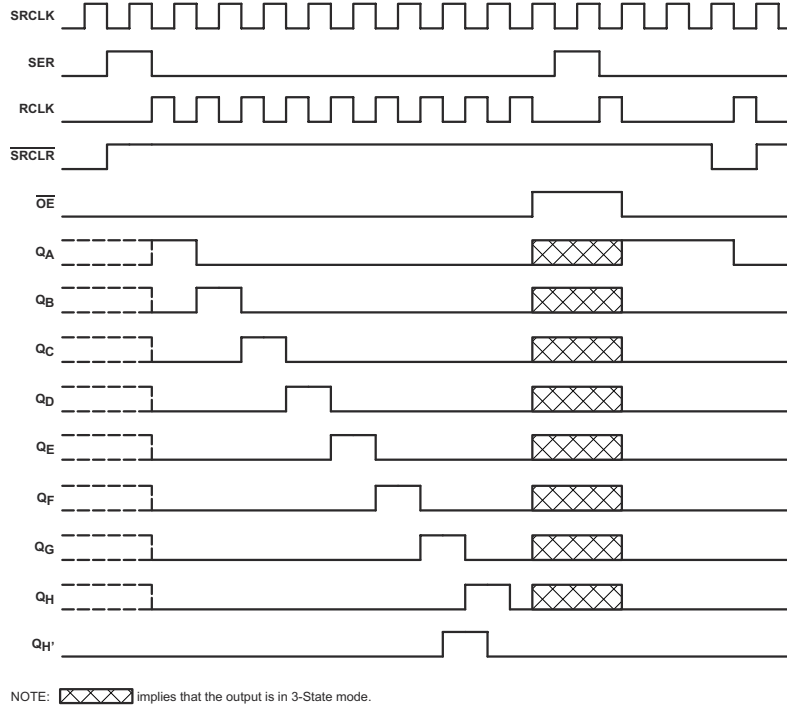

Figure 5-1. Timing Diagram

5.7 Switching Characteristics

over recommended operating free-air temperature range, $V_{CC} = 5V \pm 0.5V$ (unless otherwise noted) (see Figure 6-1)

PARAMETER	FROM (INPUT)	TO (OUTPUT)	LOAD CAPACITANCE	$T_A = 25^\circ\text{C}$			SN54AHCT595 ⁽¹⁾		SN74AHCT595		UNIT
				MIN	TYP	MAX	MIN	MAX	MIN	MAX	
f_{max}			$C_L = 15\text{ pF}$	135 ⁽²⁾	170 ⁽²⁾		115 ⁽²⁾		115	MHz	
			$C_L = 50\text{ pF}$	95	140		85		85		
t_{PLH}	RCLK	$Q_A - Q_H$	$C_L = 15\text{ pF}$	4.3 ⁽²⁾	7.4 ⁽²⁾	1 ⁽²⁾	8.5 ⁽²⁾	1	8.5	ns	
t_{PHL}				4.3 ⁽²⁾	7.4 ⁽²⁾	1 ⁽²⁾	8.5 ⁽²⁾	1	8.5		
t_{PLH}	SRCLK	$Q_{H'}$	$C_L = 15\text{ pF}$	4.5 ⁽²⁾	8.2 ⁽²⁾	1 ⁽²⁾	9.4 ⁽²⁾	1	9.4	ns	
t_{PHL}				4.5 ⁽²⁾	8.2 ⁽²⁾	1 ⁽²⁾	9.4 ⁽²⁾	1	9.4		
t_{PHL}	SRCLR	$Q_{H'}$	$C_L = 15\text{ pF}$	4.5 ⁽²⁾	8 ⁽²⁾	1 ⁽²⁾	9.1 ⁽²⁾	1	9.1	ns	
t_{PZH}	\overline{OE}	$Q_A - Q_H$	$C_L = 15\text{ pF}$	4.3 ⁽²⁾	8.6 ⁽²⁾	1 ⁽²⁾	10 ⁽²⁾	1	10	ns	
t_{PZL}				5.4 ⁽²⁾	8.6 ⁽²⁾	1 ⁽²⁾	10 ⁽²⁾	1	10		
t_{PLH}	RCLK	$Q_A - Q_H$	$C_L = 50\text{ pF}$	5.6	9.4	1	10.5	1	10.5	ns	
t_{PHL}				5.6	9.4	1	10.5	1	10.5		
t_{PLH}	SRCLK	$Q_{H'}$	$C_L = 50\text{ pF}$	6.4	10.2	1	11.4	1	11.4	ns	
t_{PHL}				6.4	10.2	1	11.4	1	11.4		
t_{PHL}	SRCLR	$Q_{H'}$	$C_L = 50\text{ pF}$	6.4	10	1	11.1	1	11.1	ns	
t_{PZH}	\overline{OE}	$Q_A - Q_H$	$C_L = 50\text{ pF}$	5.7	10.6	1	12	1	12	ns	
t_{PZL}				6.8	10.6	1	12	1	12		
t_{PHZ}	\overline{OE}	$Q_A - Q_H$	$C_L = 50\text{ pF}$	3.5	10.3	1	11	1	11	ns	
t_{PLZ}				3.4	10.3	1	11	1	11		

- (1) Product Preview
 (2) On products compliant to MIL-PRF-38535, this parameter is not production tested.

5.8 Noise Characteristics

$V_{CC} = 5V, C_L = 50\text{ pF}, T_A = 25^\circ\text{C}$

PARAMETER ⁽¹⁾		SN74AHCT595			UNIT
		MIN	TYP	MAX	
$V_{OL(P)}$	Quiet output, maximum dynamic V_{OL}		1		V
$V_{OL(V)}$	Quiet output, minimum dynamic V_{OL}		-0.6		V
$V_{OH(V)}$	Quiet output, minimum dynamic V_{OH}		3.8		V
$V_{IH(D)}$	High-level dynamic input voltage	2			V
$V_{IL(D)}$	Low-level dynamic input voltage			0.8	V

(1) Characteristics are for surface-mount packages only.

5.9 Operating Characteristics

$V_{CC} = 5V, T_A = 25^\circ\text{C}$

PARAMETER	TEST CONDITIONS	TYP	UNIT
C_{pd}	No load, $f = 1\text{ MHz}$	112	pF

5.10 Typical Characteristics

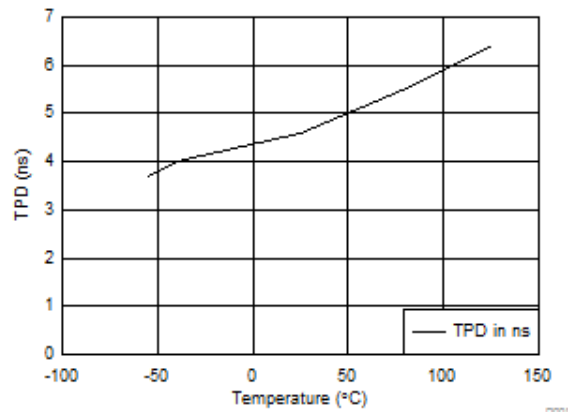

**Figure 5-2. SN74AHCT595 TPD vs Temperature, 15 pF Load
RCLK to Q**

6 Parameter Measurement Information

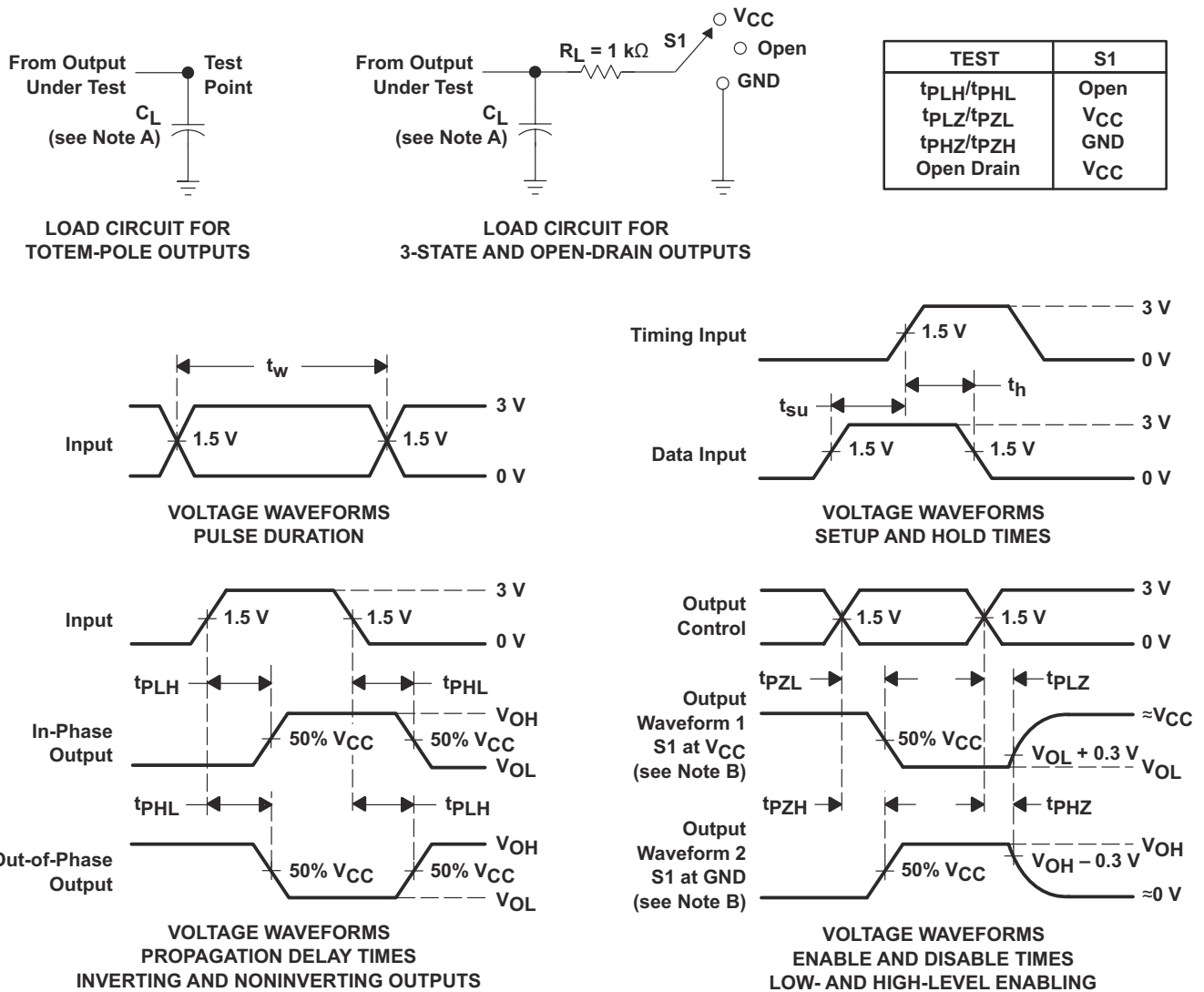

- NOTES: A. C_L includes probe and jig capacitance.
 B. Waveform 1 is for an output with internal conditions such that the output is low, except when disabled by the output control. Waveform 2 is for an output with internal conditions such that the output is high, except when disabled by the output control.
 C. All input pulses are supplied by generators having the following characteristics: PRR $\leq 1\text{ MHz}$, $Z_O = 50\ \Omega$, $t_r \leq 3\text{ ns}$, $t_f \leq 3\text{ ns}$.
 D. The outputs are measured one at a time, with one input transition per measurement.
 E. All parameters and waveforms are not applicable to all devices.

Figure 6-1. Load Circuit and Voltage Waveforms

7 Detailed Description

7.1 Overview

The SNx4AHCT595 devices contain an 8-bit serial-in, parallel-out shift register that feeds an 8-bit D-type storage register. The storage register has parallel 3-state outputs. Separate clocks are provided for the shift and storage registers. The shift register has a direct overriding clear ($\overline{\text{SRCLR}}$) input, serial (SER) input, and serial outputs for cascading. When the output-enable ($\overline{\text{OE}}$) input is high, the outputs are in the high-impedance state. Both the shift register clock (SRCLK) and storage register clock (RCLK) are positive-edge triggered. If both clocks are connected together, the shift register always is one clock pulse ahead of the storage register.

7.2 Functional Block Diagram

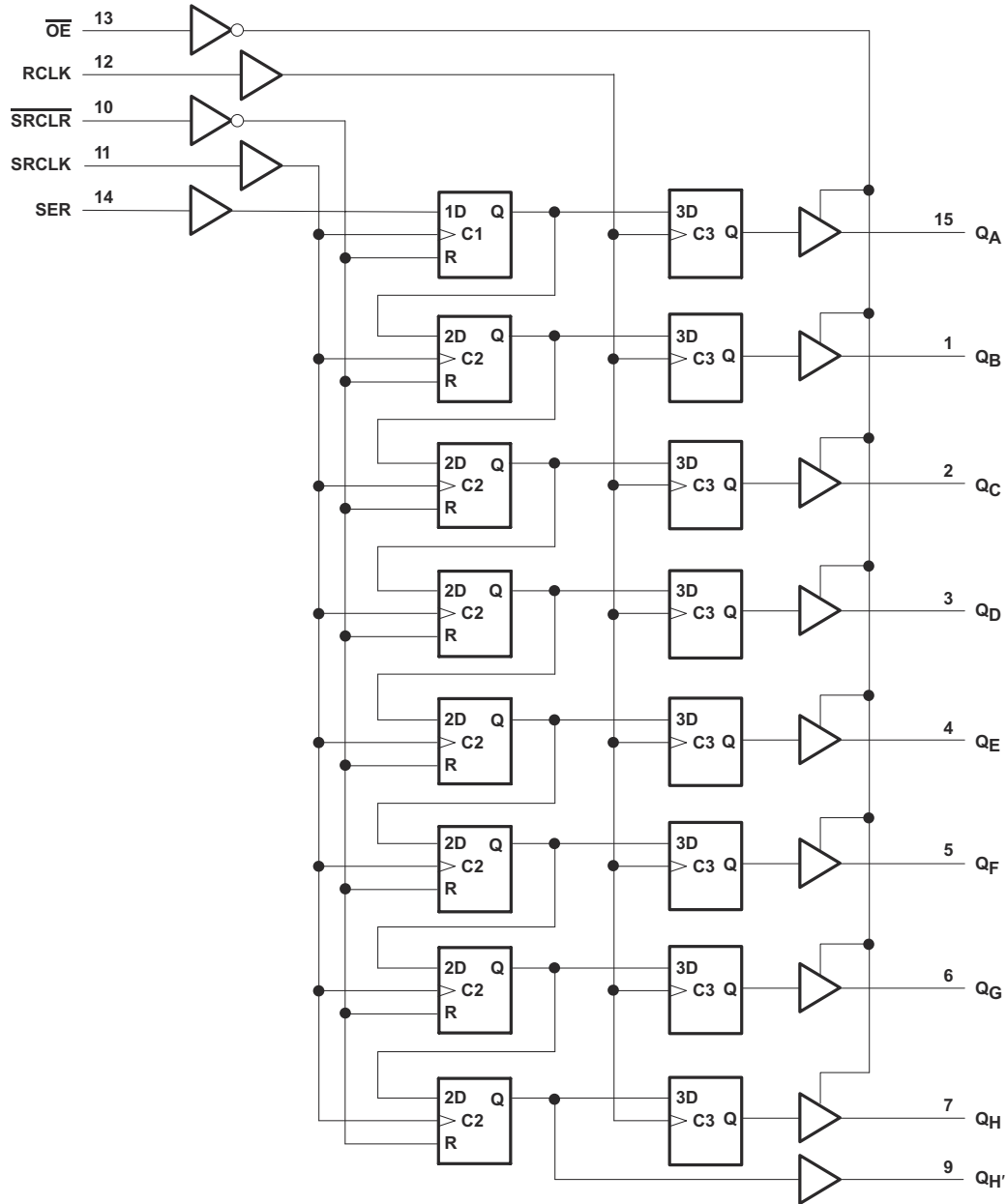

Pin numbers shown are for the D, DB, J, N, NS, PW, and W packages.

7.3 Feature Description

- Inputs are TTL-voltage compatible
- Slow edges for reduced noise
- Low power

7.4 Device Functional Modes

Table 7-1. Function Table

INPUTS					FUNCTION
SER	SRCLK	SRCLR	RCLK	\overline{OE}	
X	X	X	X	H	Outputs $Q_A - Q_H$ are disabled.
X	X	X	X	L	Outputs $Q_A - Q_H$ are enabled.
X	X	L	X	X	Shift register is cleared.
L	↑	H	X	X	First stage of the shift register goes low. Other stages store the data of previous stage, respectively.
H	↑	H	X	X	First stage of the shift register goes high. Other stages store the data of previous stage, respectively.
X	X	X	↑	X	Shift-register data is stored in the storage register.

8 Application and Implementation

Note

Information in the following applications sections is not part of the TI component specification, and TI does not warrant its accuracy or completeness. TI's customers are responsible for determining suitability of components for their purposes, as well as validating and testing their design implementation to confirm system functionality.

8.1 Application Information

The SNx4AHCT595 is a low-drive CMOS device that can be used for a multitude of bus interface type applications where output ringing is a concern. The low drive and slow edge rates will minimize overshoot and undershoot on the outputs. The input switching levels have been lowered to accommodate TTL inputs of $0.8V_{IL}$ and $2V_{IH}$. This feature makes it an excellent choice for translating up from 3.3V to 5V. Figure 8-1 shows this type of translation.

8.2 Typical Application

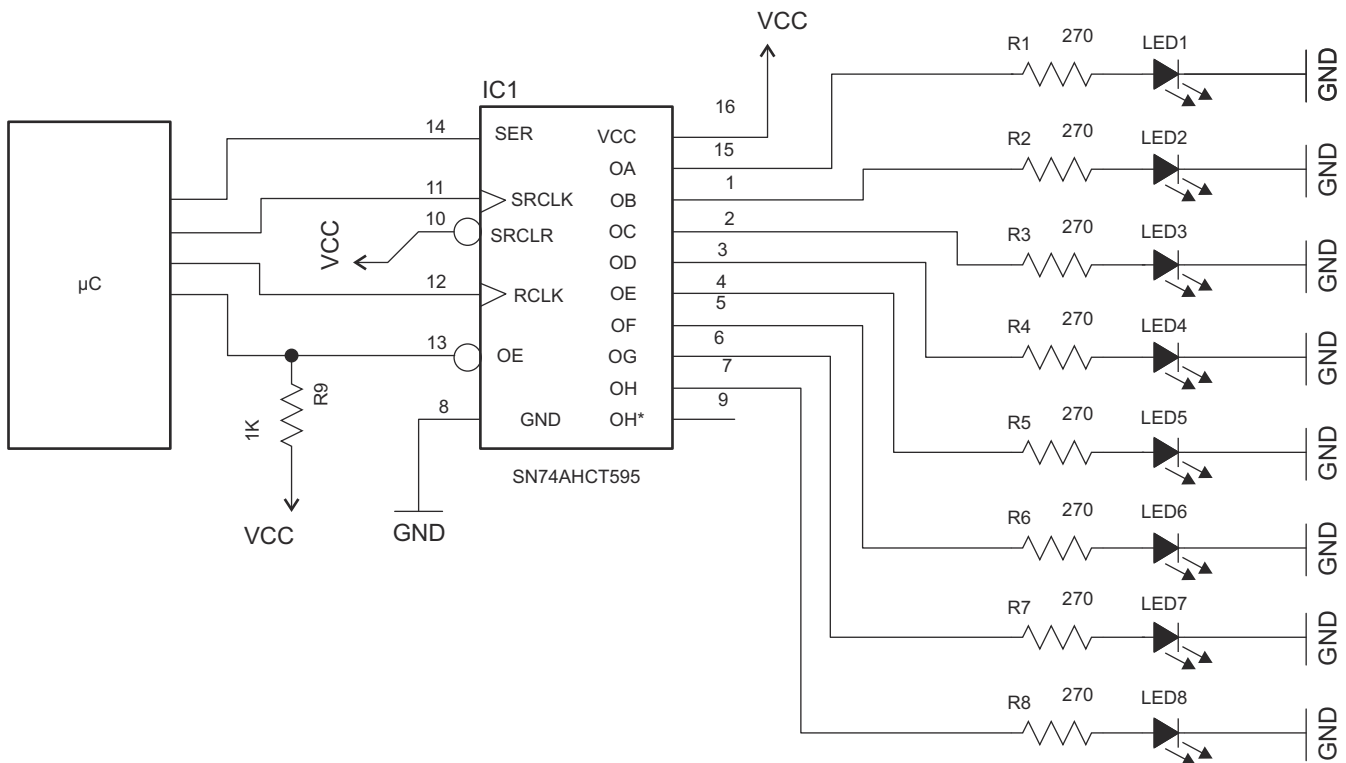

Figure 8-1. Specific Application Schematic

8.2.1 Design Requirements

This device uses CMOS technology and has balanced output drive. Care should be taken to avoid bus contention because it can drive currents that would exceed maximum limits. The high drive will also create fast edges into light loads so routing and load conditions should be considered to prevent ringing.

8.2.2 Detailed Design Procedure

- Recommended input conditions
 - Specified high and low levels. See (V_{IH} and V_{IL}) in the [Recommended Operating Conditions](#) table.
 - Specified high and low levels. See (V_{IH} and V_{IL}) in the [Recommended Operating Conditions](#) table.
 - Inputs are overvoltage tolerant allowing them to go as high as 5.5V at any valid V_{CC}

- Recommend output conditions
 - Load currents should not exceed 25mA per output and 50mA total for the part
 - Outputs should not be pulled above V_{CC}

8.2.3 Application Curves

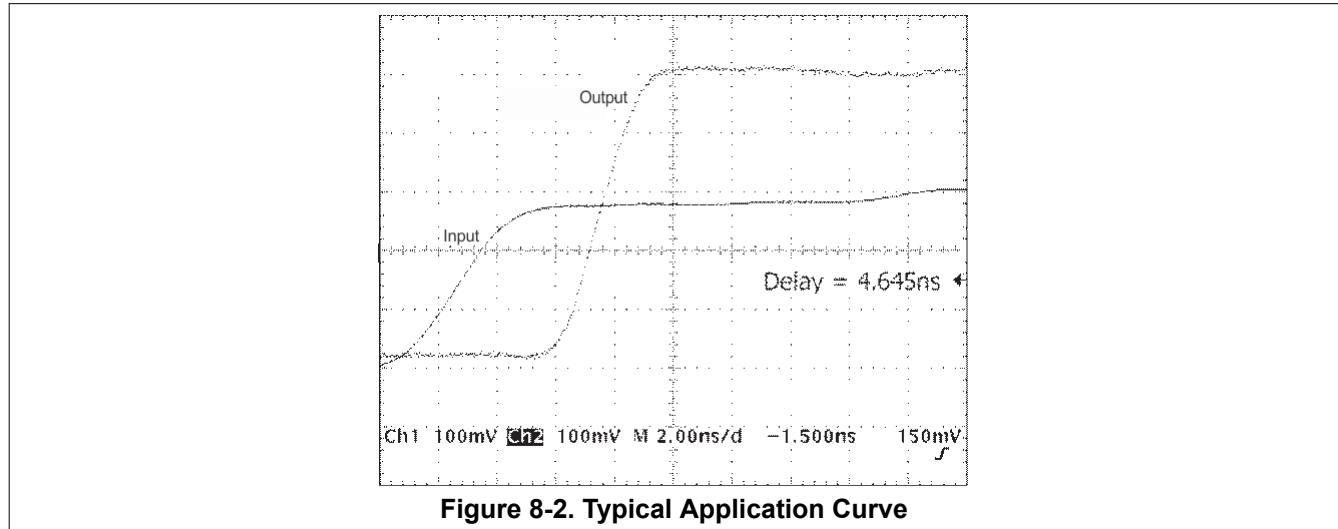

8.3 Power Supply Recommendations

The power supply can be any voltage between the MIN and MAX supply voltage rating located in the [Recommended Operating Conditions](#) table.

Each VCC pin should have a good bypass capacitor to prevent power disturbance. For devices with a single supply, 0.1 μf is recommended; if there are multiple VCC pins, then 0.01 μf or 0.022 μf is recommended for each power pin. It is acceptable to parallel multiple bypass caps to reject different frequencies of noise. A 0.1 μf and a 1 μf are commonly used in parallel. The bypass capacitor should be installed as close to the power pin as possible for best results.

8.4 Layout

8.4.1 Layout Guidelines

When using multiple-bit logic devices, inputs should never float.

In many cases, functions or parts of functions of digital logic devices are unused, for example, when only two inputs of a triple-input AND gate are used or only 3 of the 4 buffer gates are used. Such input pins should not be left unconnected because the undefined voltages at the outside connections result in undefined operational states. [Figure 8-3](#) specifies the rules that must be observed under all circumstances. All unused inputs of digital logic devices must be connected to a high or low bias to prevent them from floating. The logic level that should be applied to any particular unused input depends on the function of the device. Generally they will be tied to GND or V_{CC} , whichever makes more sense or is more convenient. It is generally acceptable to float outputs, unless the part is a transceiver. If the transceiver has an output enable pin, it will disable the output section of the part when asserted. This will not disable the input section of the I/Os, so they cannot float when disabled.

8.4.2 Layout Example

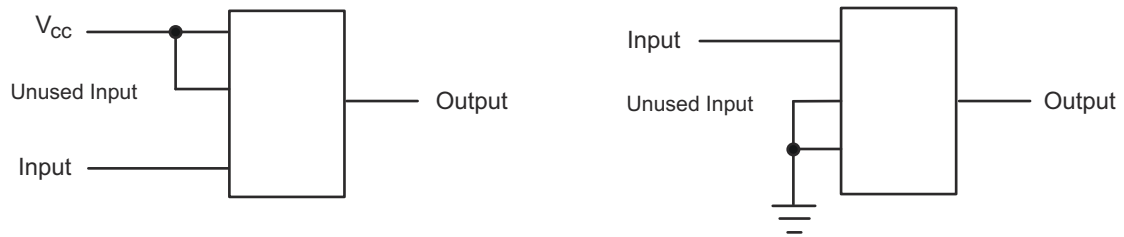

Figure 8-3. Layout Diagram

9 Device and Documentation Support

9.1 Receiving Notification of Documentation Updates

To receive notification of documentation updates, navigate to the device product folder on ti.com. Click on *Notifications* to register and receive a weekly digest of any product information that has changed. For change details, review the revision history included in any revised document.

9.2 Support Resources

TI E2E™ [support forums](#) are an engineer's go-to source for fast, verified answers and design help — straight from the experts. Search existing answers or ask your own question to get the quick design help you need.

Linked content is provided "AS IS" by the respective contributors. They do not constitute TI specifications and do not necessarily reflect TI's views; see TI's [Terms of Use](#).

9.3 Trademarks

TI E2E™ is a trademark of Texas Instruments.
All trademarks are the property of their respective owners.

9.4 Electrostatic Discharge Caution



This integrated circuit can be damaged by ESD. Texas Instruments recommends that all integrated circuits be handled with appropriate precautions. Failure to observe proper handling and installation procedures can cause damage.

ESD damage can range from subtle performance degradation to complete device failure. Precision integrated circuits may be more susceptible to damage because very small parametric changes could cause the device not to meet its published specifications.

9.5 Glossary

[TI Glossary](#) This glossary lists and explains terms, acronyms, and definitions.

10 Revision History

NOTE: Page numbers for previous revisions may differ from page numbers in the current version.

Changes from Revision O (March 2024) to Revision P (April 2024)	Page
• Updated thermal values for PW package from RθJA = 105.7 to 135.9, RθJC(top) = 40.4 to 70.3, RθJB = 50.7 to 81.3, ΨJT = 3.7 to 22.5, ΨJB = 50.1 to 80.8, all values in °C/W.....	5

Changes from Revision N (July 2020) to Revision O (March 2024)	Page
• Updated the numbering format for tables, figures and cross-references throughout the document.....	1
• Updated pin counts in Device Information table.....	1
• Updated part number in Device Information table.....	1
• Added BQB package to <i>Package Information</i> table, <i>Pin Configuration and Functions</i> section, and <i>Thermal Information</i> table.....	1

11 Mechanical, Packaging, and Orderable Information

The following pages include mechanical, packaging, and orderable information. This information is the most current data available for the designated devices. This data is subject to change without notice and revision of this document. For browser-based versions of this data sheet, refer to the left-hand navigation.

PACKAGING INFORMATION

Orderable Device	Status (1)	Package Type	Package Drawing	Pins	Package Qty	Eco Plan (2)	Lead finish/ Ball material (6)	MSL Peak Temp (3)	Op Temp (°C)	Device Marking (4/5)	Samples
SN74AHCT595BQBR	ACTIVE	WQFN	BQB	16	3000	RoHS & Green	NIPDAU	Level-1-260C-UNLIM	-40 to 125	AHT595	Samples
SN74AHCT595DBR	ACTIVE	SSOP	DB	16	2000	RoHS & Green	NIPDAU	Level-1-260C-UNLIM	-40 to 125	HB595	Samples
SN74AHCT595DR	ACTIVE	SOIC	D	16	2500	RoHS & Green	NIPDAU	Level-1-260C-UNLIM	-40 to 125	AHCT595	Samples
SN74AHCT595N	ACTIVE	PDIP	N	16	25	RoHS & Green	NIPDAU	N / A for Pkg Type	-40 to 125	SN74AHCT595N	Samples
SN74AHCT595NE4	ACTIVE	PDIP	N	16	25	RoHS & Green	NIPDAU	N / A for Pkg Type	-40 to 125	SN74AHCT595N	Samples
SN74AHCT595PWR	ACTIVE	TSSOP	PW	16	2000	RoHS & Green	NIPDAU	Level-1-260C-UNLIM	-40 to 125	HB595	Samples
SN74AHCT595PWRG3	ACTIVE	TSSOP	PW	16	2000	RoHS & Green	SN	Level-1-260C-UNLIM	-40 to 125	HB595	Samples

(1) The marketing status values are defined as follows:

ACTIVE: Product device recommended for new designs.

LIFEBUY: TI has announced that the device will be discontinued, and a lifetime-buy period is in effect.

NRND: Not recommended for new designs. Device is in production to support existing customers, but TI does not recommend using this part in a new design.

PREVIEW: Device has been announced but is not in production. Samples may or may not be available.

OBSOLETE: TI has discontinued the production of the device.

(2) **RoHS:** TI defines "RoHS" to mean semiconductor products that are compliant with the current EU RoHS requirements for all 10 RoHS substances, including the requirement that RoHS substance do not exceed 0.1% by weight in homogeneous materials. Where designed to be soldered at high temperatures, "RoHS" products are suitable for use in specified lead-free processes. TI may reference these types of products as "Pb-Free".

RoHS Exempt: TI defines "RoHS Exempt" to mean products that contain lead but are compliant with EU RoHS pursuant to a specific EU RoHS exemption.

Green: TI defines "Green" to mean the content of Chlorine (Cl) and Bromine (Br) based flame retardants meet JS709B low halogen requirements of <=1000ppm threshold. Antimony trioxide based flame retardants must also meet the <=1000ppm threshold requirement.

(3) MSL, Peak Temp. - The Moisture Sensitivity Level rating according to the JEDEC industry standard classifications, and peak solder temperature.

(4) There may be additional marking, which relates to the logo, the lot trace code information, or the environmental category on the device.

(5) Multiple Device Markings will be inside parentheses. Only one Device Marking contained in parentheses and separated by a "~" will appear on a device. If a line is indented then it is a continuation of the previous line and the two combined represent the entire Device Marking for that device.

⁽⁶⁾ Lead finish/Ball material - Orderable Devices may have multiple material finish options. Finish options are separated by a vertical ruled line. Lead finish/Ball material values may wrap to two lines if the finish value exceeds the maximum column width.

Important Information and Disclaimer:The information provided on this page represents TI's knowledge and belief as of the date that it is provided. TI bases its knowledge and belief on information provided by third parties, and makes no representation or warranty as to the accuracy of such information. Efforts are underway to better integrate information from third parties. TI has taken and continues to take reasonable steps to provide representative and accurate information but may not have conducted destructive testing or chemical analysis on incoming materials and chemicals. TI and TI suppliers consider certain information to be proprietary, and thus CAS numbers and other limited information may not be available for release.

In no event shall TI's liability arising out of such information exceed the total purchase price of the TI part(s) at issue in this document sold by TI to Customer on an annual basis.

OTHER QUALIFIED VERSIONS OF SN74AHCT595 :

- Automotive : [SN74AHCT595-Q1](#)

NOTE: Qualified Version Definitions:

- Automotive - Q100 devices qualified for high-reliability automotive applications targeting zero defects

TAPE AND REEL INFORMATION

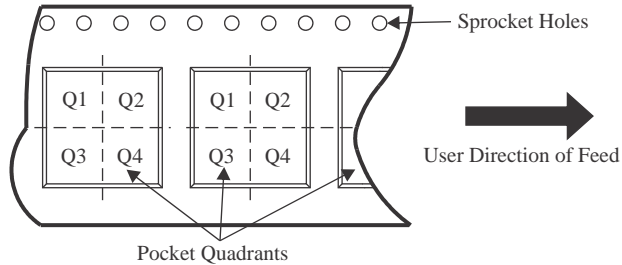
QUADRANT ASSIGNMENTS FOR PIN 1 ORIENTATION IN TAPE

*All dimensions are nominal

Device	Package Type	Package Drawing	Pins	SPQ	Reel Diameter (mm)	Reel Width W1 (mm)	A0 (mm)	B0 (mm)	K0 (mm)	P1 (mm)	W (mm)	Pin1 Quadrant
SN74AHCT595BQBR	WQFN	BQB	16	3000	180.0	12.4	2.8	3.8	1.2	4.0	12.0	Q1
SN74AHCT595DBR	SSOP	DB	16	2000	330.0	16.4	8.35	6.6	2.4	12.0	16.0	Q1
SN74AHCT595DR	SOIC	D	16	2500	330.0	16.4	6.5	10.3	2.1	8.0	16.0	Q1
SN74AHCT595PWR	TSSOP	PW	16	2000	330.0	12.4	6.9	5.6	1.6	8.0	12.0	Q1
SN74AHCT595PWG3	TSSOP	PW	16	2000	330.0	12.4	6.9	5.6	1.6	8.0	12.0	Q1

TAPE AND REEL BOX DIMENSIONS

*All dimensions are nominal

Device	Package Type	Package Drawing	Pins	SPQ	Length (mm)	Width (mm)	Height (mm)
SN74AHCT595BQBR	WQFN	BQB	16	3000	210.0	185.0	35.0
SN74AHCT595DBR	SSOP	DB	16	2000	356.0	356.0	35.0
SN74AHCT595DR	SOIC	D	16	2500	340.5	336.1	32.0
SN74AHCT595PWR	TSSOP	PW	16	2000	356.0	356.0	35.0
SN74AHCT595PWRG3	TSSOP	PW	16	2000	364.0	364.0	27.0

TUBE

*All dimensions are nominal

Device	Package Name	Package Type	Pins	SPQ	L (mm)	W (mm)	T (μm)	B (mm)
SN74AHCT595N	N	PDIP	16	25	506	13.97	11230	4.32
SN74AHCT595N	N	PDIP	16	25	506	13.97	11230	4.32
SN74AHCT595NE4	N	PDIP	16	25	506	13.97	11230	4.32
SN74AHCT595NE4	N	PDIP	16	25	506	13.97	11230	4.32

D (R-PDSO-G16)

PLASTIC SMALL OUTLINE



- NOTES:
- A. All linear dimensions are in inches (millimeters).
 - B. This drawing is subject to change without notice.
 - C. Body length does not include mold flash, protrusions, or gate burrs. Mold flash, protrusions, or gate burrs shall not exceed 0.006 (0,15) each side.
 - D. Body width does not include interlead flash. Interlead flash shall not exceed 0.017 (0,43) each side.
 - E. Reference JEDEC MS-012 variation AC.

D (R-PDSO-G16)

PLASTIC SMALL OUTLINE



- NOTES:
- A. All linear dimensions are in millimeters.
 - B. This drawing is subject to change without notice.
 - C. Publication IPC-7351 is recommended for alternate designs.
 - D. Laser cutting apertures with trapezoidal walls and also rounding corners will offer better paste release. Customers should contact their board assembly site for stencil design recommendations. Refer to IPC-7525 for other stencil recommendations.
 - E. Customers should contact their board fabrication site for solder mask tolerances between and around signal pads.



4220204/A 02/2017

NOTES:

1. All linear dimensions are in millimeters. Any dimensions in parenthesis are for reference only. Dimensioning and tolerancing per ASME Y14.5M.
2. This drawing is subject to change without notice.
3. This dimension does not include mold flash, protrusions, or gate burrs. Mold flash, protrusions, or gate burrs shall not exceed 0.15 mm per side.
4. This dimension does not include interlead flash. Interlead flash shall not exceed 0.25 mm per side.
5. Reference JEDEC registration MO-153.

EXAMPLE BOARD LAYOUT

PW0016A

TSSOP - 1.2 mm max height

SMALL OUTLINE PACKAGE



LAND PATTERN EXAMPLE
EXPOSED METAL SHOWN
SCALE: 10X

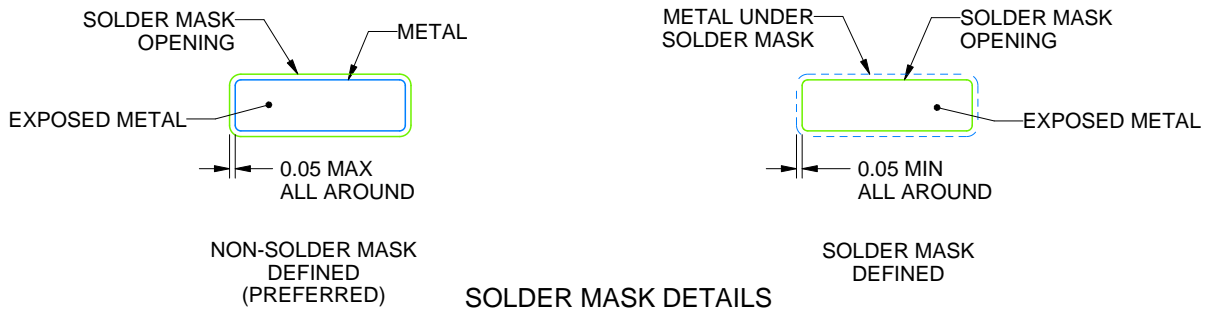

SOLDER MASK DETAILS

4220204/A 02/2017

NOTES: (continued)

- 6. Publication IPC-7351 may have alternate designs.
- 7. Solder mask tolerances between and around signal pads can vary based on board fabrication site.

EXAMPLE STENCIL DESIGN

PW0016A

TSSOP - 1.2 mm max height

SMALL OUTLINE PACKAGE



SOLDER PASTE EXAMPLE
BASED ON 0.125 mm THICK STENCIL
SCALE: 10X

4220204/A 02/2017

NOTES: (continued)

8. Laser cutting apertures with trapezoidal walls and rounded corners may offer better paste release. IPC-7525 may have alternate design recommendations.
9. Board assembly site may have different recommendations for stencil design.

DB0016A



PACKAGE OUTLINE

SSOP - 2 mm max height

SMALL OUTLINE PACKAGE



4220763/A 05/2022

NOTES:

- All linear dimensions are in millimeters. Any dimensions in parenthesis are for reference only. Dimensioning and tolerancing per ASME Y14.5M.
- This drawing is subject to change without notice.
- This dimension does not include mold flash, protrusions, or gate burrs. Mold flash, protrusions, or gate burrs shall not exceed 0.15 mm per side.
- Reference JEDEC registration MO-150.

EXAMPLE BOARD LAYOUT

DB0016A

SSOP - 2 mm max height

SMALL OUTLINE PACKAGE



LAND PATTERN EXAMPLE
EXPOSED METAL SHOWN
SCALE: 10X



4220763/A 05/2022

NOTES: (continued)

- 5. Publication IPC-7351 may have alternate designs.
- 6. Solder mask tolerances between and around signal pads can vary based on board fabrication site.

EXAMPLE STENCIL DESIGN

DB0016A

SSOP - 2 mm max height

SMALL OUTLINE PACKAGE



SOLDER PASTE EXAMPLE
BASED ON 0.125 mm THICK STENCIL
SCALE: 10X

4220763/A 05/2022

NOTES: (continued)

7. Laser cutting apertures with trapezoidal walls and rounded corners may offer better paste release. IPC-7525 may have alternate design recommendations.
8. Board assembly site may have different recommendations for stencil design.

GENERIC PACKAGE VIEW

BQB 16

WQFN - 0.8 mm max height

2.5 x 3.5, 0.5 mm pitch

PLASTIC QUAD FLATPACK - NO LEAD

This image is a representation of the package family, actual package may vary.
Refer to the product data sheet for package details.

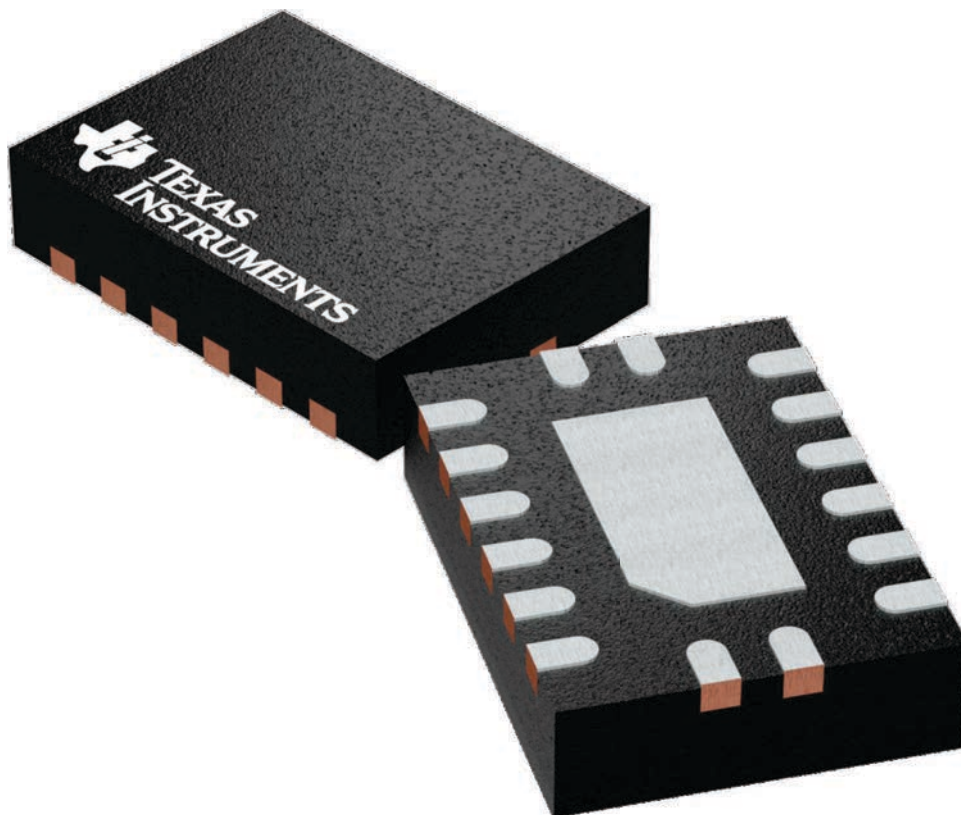

4226161/A

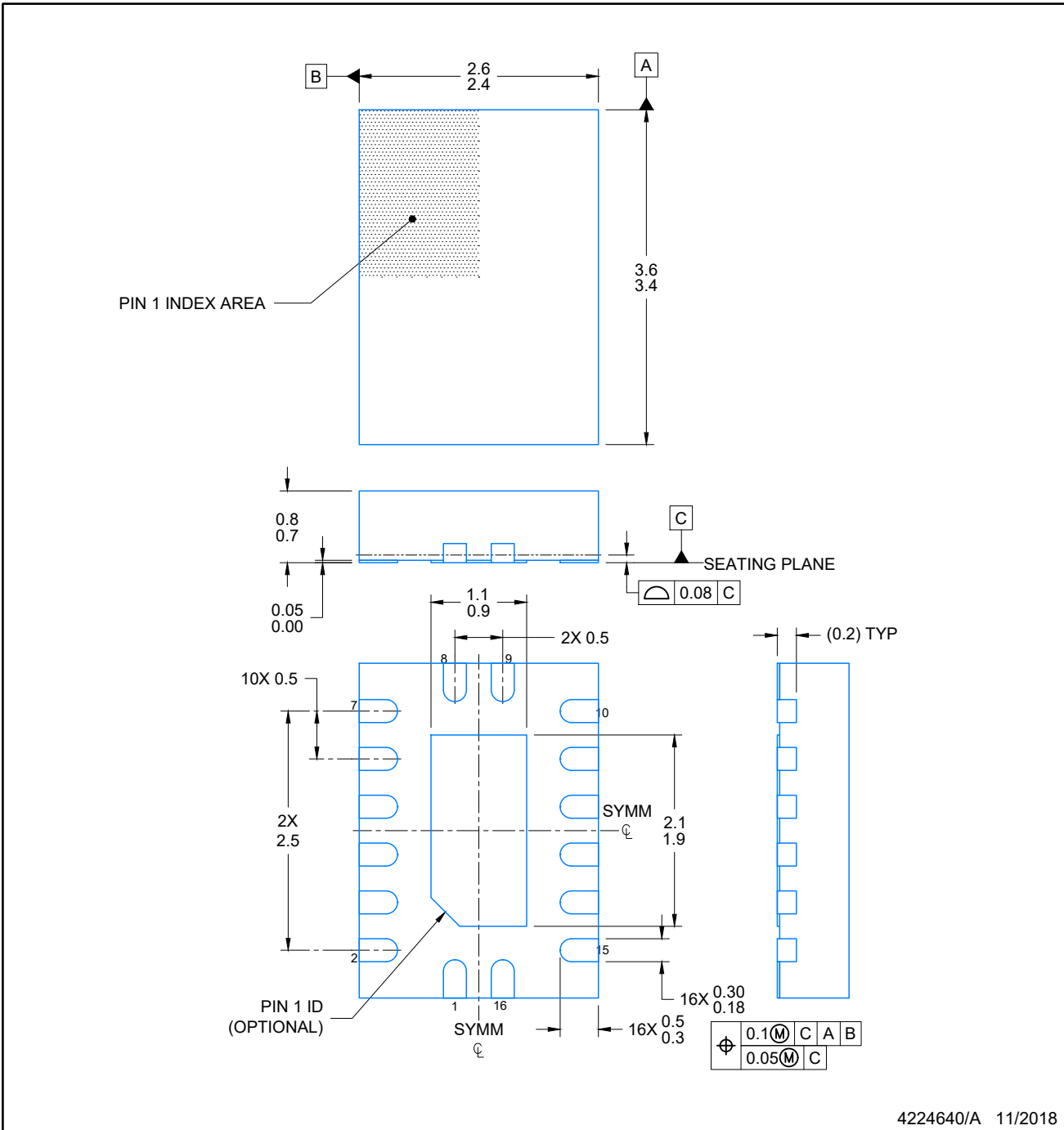

4224640/A 11/2018

NOTES:

1. All linear dimensions are in millimeters. Any dimensions in parenthesis are for reference only. Dimensioning and tolerancing per ASME Y14.5M.
2. This drawing is subject to change without notice.
3. The package thermal pad must be soldered to the printed circuit board for optimal thermal and mechanical performance.

EXAMPLE STENCIL DESIGN

BQB0016A

WQFN - 0.8 mm max height

PLASTIC QUAD FLAT PACK-NO LEAD

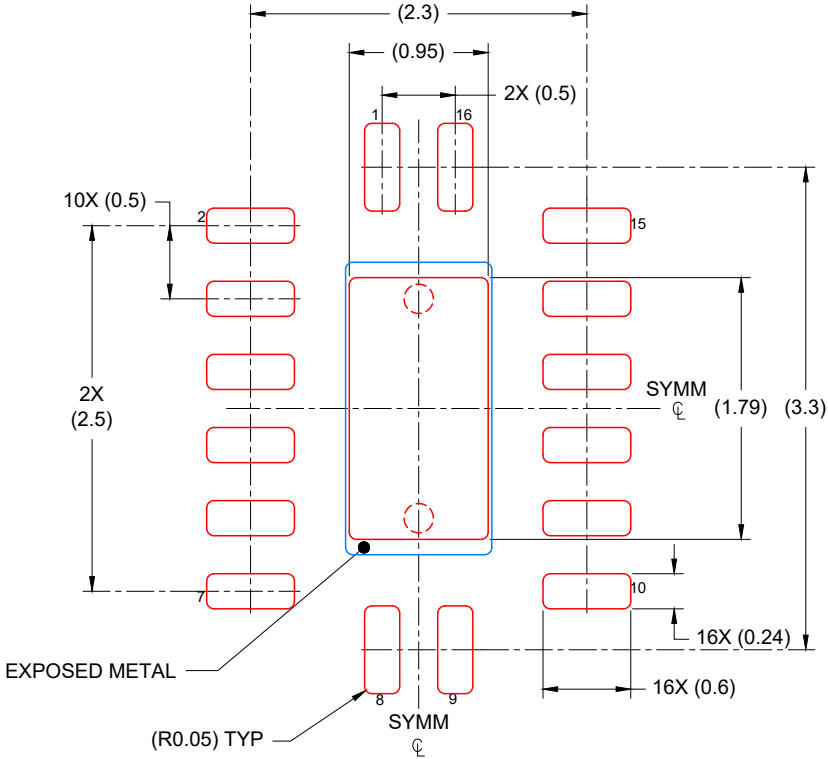

SOLDER PASTE EXAMPLE
 BASED ON 0.125 mm THICK STENCIL

EXPOSED PAD
 85% PRINTED COVERAGE BY AREA
 SCALE: 20X

4224640/A 11/2018

NOTES: (continued)

- 6. Laser cutting apertures with trapezoidal walls and rounded corners may offer better paste release. IPC-7525 may have alternate design recommendations.

N (R-PDIP-T**)

PLASTIC DUAL-IN-LINE PACKAGE

16 PINS SHOWN



- NOTES:
- A. All linear dimensions are in inches (millimeters).
 - B. This drawing is subject to change without notice.
 - $\triangle C$ Falls within JEDEC MS-001, except 18 and 20 pin minimum body length (Dim A).
 - $\triangle D$ The 20 pin end lead shoulder width is a vendor option, either half or full width.

IMPORTANT NOTICE AND DISCLAIMER

TI PROVIDES TECHNICAL AND RELIABILITY DATA (INCLUDING DATA SHEETS), DESIGN RESOURCES (INCLUDING REFERENCE DESIGNS), APPLICATION OR OTHER DESIGN ADVICE, WEB TOOLS, SAFETY INFORMATION, AND OTHER RESOURCES "AS IS" AND WITH ALL FAULTS, AND DISCLAIMS ALL WARRANTIES, EXPRESS AND IMPLIED, INCLUDING WITHOUT LIMITATION ANY IMPLIED WARRANTIES OF MERCHANTABILITY, FITNESS FOR A PARTICULAR PURPOSE OR NON-INFRINGEMENT OF THIRD PARTY INTELLECTUAL PROPERTY RIGHTS.

These resources are intended for skilled developers designing with TI products. You are solely responsible for (1) selecting the appropriate TI products for your application, (2) designing, validating and testing your application, and (3) ensuring your application meets applicable standards, and any other safety, security, regulatory or other requirements.

These resources are subject to change without notice. TI grants you permission to use these resources only for development of an application that uses the TI products described in the resource. Other reproduction and display of these resources is prohibited. No license is granted to any other TI intellectual property right or to any third party intellectual property right. TI disclaims responsibility for, and you will fully indemnify TI and its representatives against, any claims, damages, costs, losses, and liabilities arising out of your use of these resources.

TI's products are provided subject to [TI's Terms of Sale](#) or other applicable terms available either on [ti.com](https://www.ti.com) or provided in conjunction with such TI products. TI's provision of these resources does not expand or otherwise alter TI's applicable warranties or warranty disclaimers for TI products.

TI objects to and rejects any additional or different terms you may have proposed.

Mailing Address: Texas Instruments, Post Office Box 655303, Dallas, Texas 75265
Copyright © 2024, Texas Instruments Incorporated

Looking for pricing, stock, or lifecycle information?

Click below to explore more details on WIN SOURCE:

 [View SN74AHCT595PW on WIN SOURCE](#)

 [Texas Instruments](#) Information

Optimize Your Supply Chain with WIN SOURCE Solutions

-  Global Sourcing Solution
-  Obsolete Management
-  Cost Control Management
-  Shortage Management
-  Alternative Solution
-  Excess Inventory Management