



# THE DATASHEET OF SN74ALS30AD



## 8-INPUT POSITIVE-NAND GATES

 Check for Samples: [SN54ALS30A](#), [SN54AS30](#), [SN74ALS30A](#), [SN74AS30](#)

### FEATURES

- 8-Input Positive-NAND Gates
- Available in J, DW, N, and FK Packages

### DESCRIPTION

These devices contain an 8-input positive-NAND gate and perform the following Boolean functions in positive logic:

$$Y = \overline{A \cdot B \cdot C \cdot D \cdot E \cdot F \cdot G \cdot H}$$

or

$$Y = \overline{A} + \overline{B} + \overline{C} + \overline{D} + \overline{E} + \overline{F} + \overline{G}$$

SN54ALS30A, SN54AS30 . . . J PACKAGE  
SN74ALS30A, SN74AS30 . . . DW OR N PACKAGE  
SN74AS30 . . . DB PACKAGE

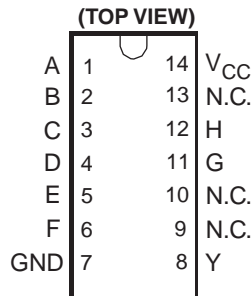

SN54ALS30A, SN54AS30 . . . FK PACKAGE  
(TOP VIEW)

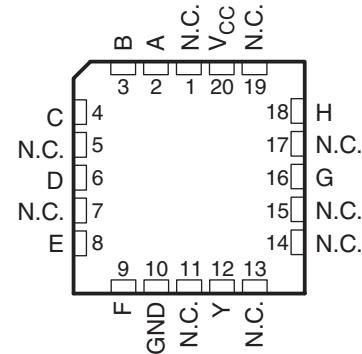

N.C. – No internal connection

### ORDERING INFORMATION

T <sub>A</sub>	PACKAGE <sup>(1) (2)</sup>		ORDERABLE PART NUMBER	TOP-SIDE MARKING
0°C to 70°C	PDIP – N	Tube	SN74ALS30AN	SN74ALS30AN
			SN74AS30N	SN74AS30N
	SOIC – D	Tube	SN74AS30AD	ALS30A
		Tape and reel	SN74ALS30ADR	
		Tube	SN74AS30D	AS30
		Tape and reel	SN74AS30DR	
SSOP – DB	Tape and reel	SN74AS30DBR	AS30	
–55°C to 125°C	CDIP – J	Tube	SNJ54ALS30AJ	SNJ54ALS30AJ
			SNJ54AS30J	SNJ54AS30J
	LCCC –FK	Tube	SNJ54ALS30AFK	SNJ54ALS30AFK
			SNJ54AS30FK	SNJ54AS30FK

(1) Package drawings, thermal data, and symbolization are available at [www.ti.com/packaging](http://www.ti.com/packaging).

(2) For the most current package and ordering information, see the Package Option Addendum at the end of this document, or see the TI website at [www.ti.com](http://www.ti.com).



Please be aware that an important notice concerning availability, standard warranty, and use in critical applications of Texas Instruments semiconductor products and disclaimers thereto appears at the end of this data sheet.

**Table 1. FUNCTION TABLE**

INPUTS A–H	OUTPUT Y
All inputs H	L
One or more inputs L	H

**LOGIC SYMBOL**

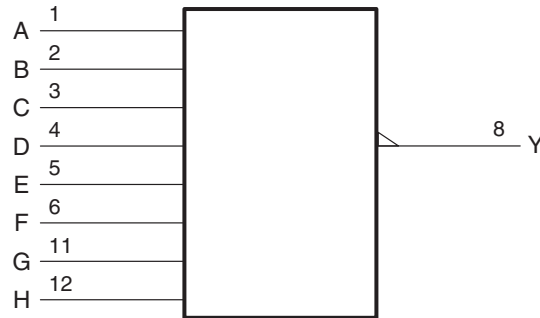

A. This symbol is in accordance with ANSI/IEEE Std 91-1984 and IEC Publication 617-12. Pin number shown are for the D, DB, J, and N packages.

**LOGIC DIAGRAM (POSITIVE LOGIC)**

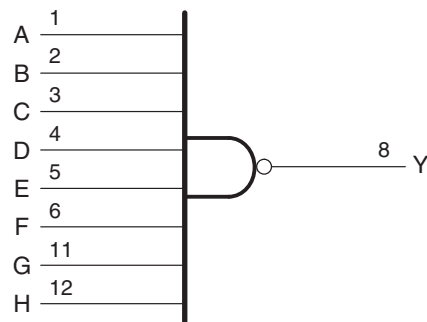

Pin number shown are for the D, DB, J, and N packages.

**ABSOLUTE MAXIMUM RATINGS<sup>(1)</sup>**

over operating free-air temperature range (unless otherwise noted)

		MIN	MAX	UNIT
$V_{CC}$	Supply voltage range	-0.5	7	V
$V_I$	Input voltage range	-0.5	7	V
$\theta_{JA}$	Package thermal impedance <sup>(2)</sup>	D package	86	°C/W
		DB package	96	
		N package	80	
$T_{stg}$	Storage temperature range	-65	150	°C

- (1) Stresses beyond those listed under “absolute maximum ratings” may cause permanent damage to the device. These are stress ratings only, and functional operation of the device at these or any other conditions beyond those indicated under “recommended operating conditions” is not implied. Exposure to absolute-maximum-rated conditions for extended periods may affect device reliability.
- (2) The package thermal impedance is calculated in accordance with JESD 51-7.

## RECOMMENDED OPERATING CONDITIONS

over operating free-air temperature range (unless otherwise noted)

		MIN	NOM	MAX	UNIT
V <sub>CC</sub>	Supply voltage	4.5	5	5.5	V
V <sub>IH</sub>	High-level input voltage	2			V
V <sub>IL</sub>	Low-level input voltage			0.8 <sup>(1)</sup>	V
				0.7 <sup>(2)</sup>	
I <sub>OH</sub>	High-level output current	'ALS30A		-0.4	mA
		'AS30		-2	
I <sub>OL</sub>	Low-level output current	SN54ALS30A		4	mA
		SN74ALS30A		8	
		'AS30		20	
T <sub>A</sub>	Operating free-air temperature	SN54ALS30A, SN54AS30	-55	125	°C
		SN74ALS30A, SN74AS30	0	70	

- (1) Applies to the 'AS30 and SN74ALS30A across the full operating temperature range, and SN54ALS30A over the temperature range of -55°C to 7°C.  
 (2) Applies to the SN54ALS30A over the temperature range of 70°C to 125°C.

## ELECTRICAL CHARACTERISTICS

over operating free-air temperature range (unless otherwise noted)

PARAMETER	TEST CONDITIONS		MIN	TYP <sup>(1)</sup>	MAX	UNIT
V <sub>IK</sub>	V <sub>CC</sub> = 4.5 V,	I <sub>I</sub> = -18 mA	'ALS30A 'AS30		-1.5	V
V <sub>OH</sub>	V <sub>CC</sub> = 4.5 V to 5.5 V,	I <sub>OH</sub> = -0.4 mA	'ALS30A	V <sub>CC</sub> - 2		V
		I <sub>OH</sub> = -2 mA	'AS30	V <sub>CC</sub> - 2		
V <sub>OL</sub>	V <sub>CC</sub> = 4.5 V	I <sub>OL</sub> = 4 mA	'ALS30A	0.25	0.4	V
		I <sub>OL</sub> = 8 mA	SN74ALS30A	0.35	0.5	
		I <sub>OL</sub> = 20 mA	'AS30	0.35	0.5	
I <sub>I</sub>	V <sub>CC</sub> = 5.5 V,	V <sub>I</sub> = 7 V			0.1	mA
I <sub>IH</sub>	V <sub>CC</sub> = 5.5 V,	V <sub>I</sub> = 2.7 V			20	µA
I <sub>IL</sub>	V <sub>CC</sub> = 5.5 V,	V <sub>I</sub> = 0.4 V	'ALS30A		-0.1	mA
			'AS30		-0.5	
I <sub>O</sub> <sup>(2)</sup>	V <sub>CC</sub> = 5.5 V,	V <sub>O</sub> = 2.25 V	SN54ALS30A	-20	-112	mA
			SN74ALS30A	-30	-112	
			'AS30	-30	-112	
I <sub>CCH</sub>	V <sub>CC</sub> = 5.5 V,	V <sub>I</sub> = 0 V	'ALS30A	0.22	0.36	mA
			'AS30	0.9	1.5	
I <sub>CCL</sub>	V <sub>CC</sub> = 5.5 V,	V <sub>I</sub> = 4.5 V	'ALS30A	0.54	0.9	mA
			'AS30	3	4.9	

- (1) All typical values are at V<sub>CC</sub> = 5 V, T<sub>A</sub> = 25°C.  
 (2) The output conditions have been chosen to produce a current that closely approximates one half of the true short-circuit output current, I<sub>OS</sub>.

## SWITCHING CHARACTERISTICS

 over recommended operating conditions (unless otherwise noted (see [Figure 1](#)))

PARAMETER	FROM (INPUT)	TO (OUTPUT)		MIN	MAX	UNIT
t <sub>PLH</sub>	A, B, C, D, E, F, G, or H	Y	SN54ALS30A	3	15	ns
			SN74ALS30A	3	10	
			SN54AS30	1	5.5	
			SN74AS30	1	5	

**SWITCHING CHARACTERISTICS (continued)**

over recommended operating conditions (unless otherwise noted (see [Figure 1](#)))

PARAMETER	FROM (INPUT)	TO (OUTPUT)		MIN	MAX	UNIT
t <sub>PHL</sub>	A, B, C, D, E, F, G, or H	Y	SN54ALS30A	3	15	ns
			SN74ALS30A	3	12	
			SN54AS30	1	5	
			SN74AS30	1	4.5	

PARAMETER MEASUREMENT INFORMATION

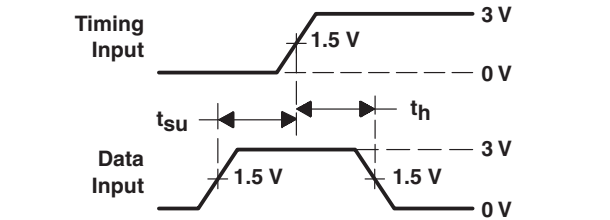
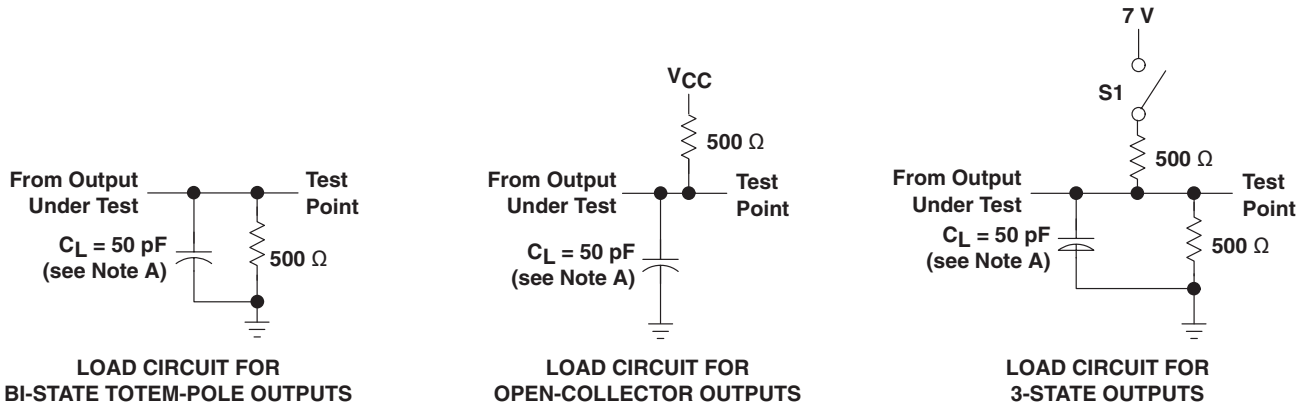

VOLTAGE WAVEFORMS SETUP AND HOLD TIMES

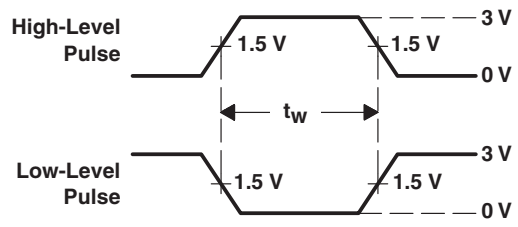

VOLTAGE WAVEFORMS PULSE DURATIONS

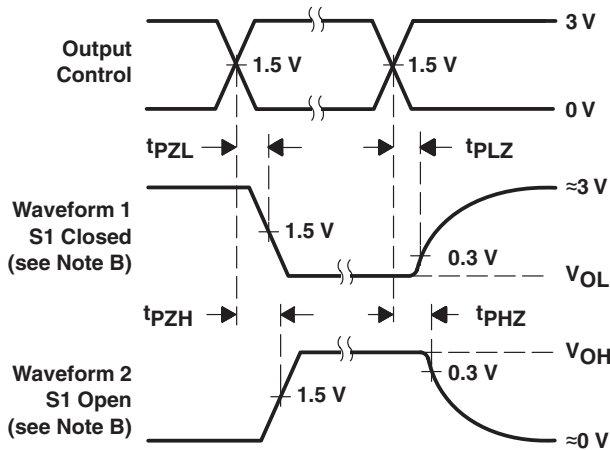

VOLTAGE WAVEFORMS ENABLE AND DISABLE TIMES, 3-STATE OUTPUTS

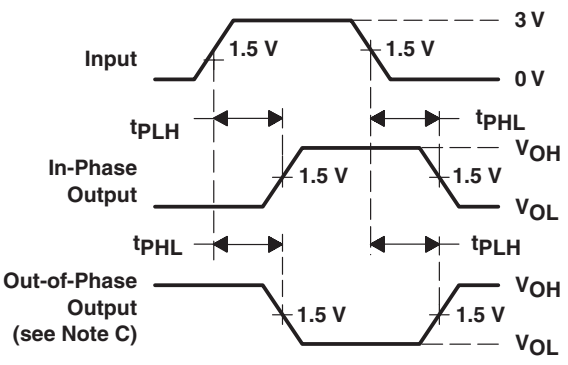

VOLTAGE WAVEFORMS PROPAGATION DELAY TIMES

- A.  $C_L$  includes probe and jig capacitance.
- B. Waveform 1 is for an output with internal conditions such that the output is low except when disabled by the output control. Waveform 2 is for an output with internal conditions such that the output is high except when disabled by the output control.
- C. When measuring propagation delay items of 3-state outputs, switch S1 is open.
- D. All input pulses have the following characteristics:  $PRR \leq 1$  MHz,  $t_r = t_f = 2$  ns, duty cycle = 50%.
- E. The outputs are measured one at a time with one transition per measurement.

Figure 1. Load Circuits and Voltage Waveforms

## REVISION HISTORY

Changes from Original (April 2009) to Revision E	Page
• Updated ORDERING INFORMATION table. ....	1

**PACKAGING INFORMATION**

Orderable Device	Status (1)	Package Type	Package Drawing	Pins	Package Qty	Eco Plan (2)	Lead finish/ Ball material (6)	MSL Peak Temp (3)	Op Temp (°C)	Device Marking (4/5)	Samples
5962-86837012A	ACTIVE	LCCC	FK	20	55	Non-RoHS & Green	SNPB	N / A for Pkg Type	-55 to 125	5962- 86837012A SNJ54ALS 30AFK	<a href="#">Samples</a>
5962-8683701DA	ACTIVE	CFP	W	14	25	Non-RoHS & Green	SNPB	N / A for Pkg Type	-55 to 125	5962-8683701DA SNJ54ALS30AW	<a href="#">Samples</a>
5962-9755801QCA	ACTIVE	CDIP	J	14	25	Non-RoHS & Green	SNPB	N / A for Pkg Type	-55 to 125	5962-9755801QC A SNJ54AS30J	<a href="#">Samples</a>
JM38510/37004B2A	ACTIVE	LCCC	FK	20	55	Non-RoHS & Green	SNPB	N / A for Pkg Type	-55 to 125	JM38510/ 37004B2A	<a href="#">Samples</a>
JM38510/37004BCA	ACTIVE	CDIP	J	14	25	Non-RoHS & Green	SNPB	N / A for Pkg Type	-55 to 125	JM38510/ 37004BCA	<a href="#">Samples</a>
M38510/37004B2A	ACTIVE	LCCC	FK	20	55	Non-RoHS & Green	SNPB	N / A for Pkg Type	-55 to 125	JM38510/ 37004B2A	<a href="#">Samples</a>
M38510/37004BCA	ACTIVE	CDIP	J	14	25	Non-RoHS & Green	SNPB	N / A for Pkg Type	-55 to 125	JM38510/ 37004BCA	<a href="#">Samples</a>
SN54ALS30AJ	ACTIVE	CDIP	J	14	25	Non-RoHS & Green	SNPB	N / A for Pkg Type	-55 to 125	SN54ALS30AJ	<a href="#">Samples</a>
SN74ALS30ADB	ACTIVE	SSOP	DB	14	80	RoHS & Green	NIPDAU	Level-1-260C-UNLIM		G30A	<a href="#">Samples</a>
SN74ALS30ADBE4	ACTIVE	SSOP	DB	14	80	RoHS & Green	NIPDAU	Level-1-260C-UNLIM		G30A	<a href="#">Samples</a>
SN74ALS30ADR	ACTIVE	SOIC	D	14	2500	RoHS & Green	NIPDAU	Level-1-260C-UNLIM	0 to 70	ALS30A	<a href="#">Samples</a>
SN74ALS30AN	ACTIVE	PDIP	N	14	25	RoHS & Green	NIPDAU	N / A for Pkg Type	0 to 70	SN74ALS30AN	<a href="#">Samples</a>
SN74AS30DR	ACTIVE	SOIC	D	14	2500	RoHS & Green	NIPDAU	Level-1-260C-UNLIM	0 to 70	AS30	<a href="#">Samples</a>
SN74AS30N	ACTIVE	PDIP	N	14	25	RoHS & Green	NIPDAU	N / A for Pkg Type	0 to 70	SN74AS30N	<a href="#">Samples</a>
SNJ54ALS30AFK	ACTIVE	LCCC	FK	20	55	Non-RoHS & Green	SNPB	N / A for Pkg Type	-55 to 125	5962- 86837012A SNJ54ALS 30AFK	<a href="#">Samples</a>

Orderable Device	Status (1)	Package Type	Package Drawing	Pins	Package Qty	Eco Plan (2)	Lead finish/ Ball material (6)	MSL Peak Temp (3)	Op Temp (°C)	Device Marking (4/5)	Samples
SNJ54ALS30AJ	ACTIVE	CDIP	J	14	25	Non-RoHS & Green	SNPB	N / A for Pkg Type	-55 to 125	SNJ54ALS30AJ	<a href="#">Samples</a>
SNJ54ALS30AW	ACTIVE	CFP	W	14	25	Non-RoHS & Green	SNPB	N / A for Pkg Type	-55 to 125	5962-8683701DA SNJ54ALS30AW	<a href="#">Samples</a>
SNJ54AS30J	ACTIVE	CDIP	J	14	25	Non-RoHS & Green	SNPB	N / A for Pkg Type	-55 to 125	5962-9755801QC A SNJ54AS30J	<a href="#">Samples</a>

(1) The marketing status values are defined as follows:

**ACTIVE:** Product device recommended for new designs.

**LIFEBUY:** TI has announced that the device will be discontinued, and a lifetime-buy period is in effect.

**NRND:** Not recommended for new designs. Device is in production to support existing customers, but TI does not recommend using this part in a new design.

**PREVIEW:** Device has been announced but is not in production. Samples may or may not be available.

**OBSOLETE:** TI has discontinued the production of the device.

(2) **RoHS:** TI defines "RoHS" to mean semiconductor products that are compliant with the current EU RoHS requirements for all 10 RoHS substances, including the requirement that RoHS substance do not exceed 0.1% by weight in homogeneous materials. Where designed to be soldered at high temperatures, "RoHS" products are suitable for use in specified lead-free processes. TI may reference these types of products as "Pb-Free".

**RoHS Exempt:** TI defines "RoHS Exempt" to mean products that contain lead but are compliant with EU RoHS pursuant to a specific EU RoHS exemption.

**Green:** TI defines "Green" to mean the content of Chlorine (Cl) and Bromine (Br) based flame retardants meet JS709B low halogen requirements of <=1000ppm threshold. Antimony trioxide based flame retardants must also meet the <=1000ppm threshold requirement.

(3) MSL, Peak Temp. - The Moisture Sensitivity Level rating according to the JEDEC industry standard classifications, and peak solder temperature.

(4) There may be additional marking, which relates to the logo, the lot trace code information, or the environmental category on the device.

(5) Multiple Device Markings will be inside parentheses. Only one Device Marking contained in parentheses and separated by a "~" will appear on a device. If a line is indented then it is a continuation of the previous line and the two combined represent the entire Device Marking for that device.

(6) Lead finish/Ball material - Orderable Devices may have multiple material finish options. Finish options are separated by a vertical ruled line. Lead finish/Ball material values may wrap to two lines if the finish value exceeds the maximum column width.

**Important Information and Disclaimer:**The information provided on this page represents TI's knowledge and belief as of the date that it is provided. TI bases its knowledge and belief on information provided by third parties, and makes no representation or warranty as to the accuracy of such information. Efforts are underway to better integrate information from third parties. TI has taken and continues to take reasonable steps to provide representative and accurate information but may not have conducted destructive testing or chemical analysis on incoming materials and chemicals. TI and TI suppliers consider certain information to be proprietary, and thus CAS numbers and other limited information may not be available for release.

In no event shall TI's liability arising out of such information exceed the total purchase price of the TI part(s) at issue in this document sold by TI to Customer on an annual basis.

**OTHER QUALIFIED VERSIONS OF SN54ALS30A, SN54AS30, SN74ALS30A, SN74AS30 :**

- Catalog : [SN74ALS30A](#), [SN74AS30](#)
- Military : [SN54ALS30A](#), [SN54AS30](#)

NOTE: Qualified Version Definitions:

- Catalog - TI's standard catalog product
- Military - QML certified for Military and Defense Applications

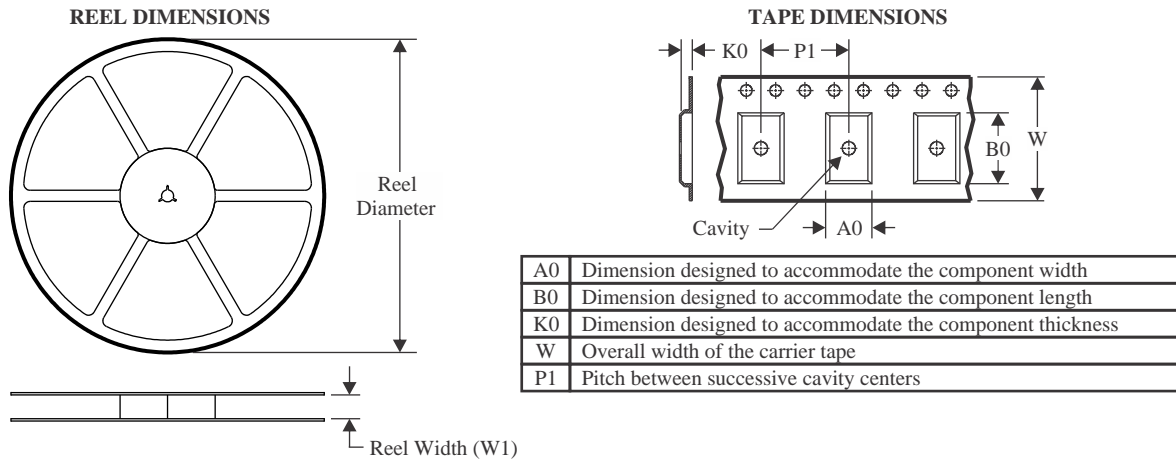
**TAPE AND REEL INFORMATION**

**QUADRANT ASSIGNMENTS FOR PIN 1 ORIENTATION IN TAPE**

\*All dimensions are nominal

Device	Package Type	Package Drawing	Pins	SPQ	Reel Diameter (mm)	Reel Width W1 (mm)	A0 (mm)	B0 (mm)	K0 (mm)	P1 (mm)	W (mm)	Pin1 Quadrant
SN74ALS30ADR	SOIC	D	14	2500	330.0	16.4	6.5	9.0	2.1	8.0	16.0	Q1
SN74AS30DR	SOIC	D	14	2500	330.0	16.4	6.5	9.0	2.1	8.0	16.0	Q1

**TAPE AND REEL BOX DIMENSIONS**

\*All dimensions are nominal

Device	Package Type	Package Drawing	Pins	SPQ	Length (mm)	Width (mm)	Height (mm)
SN74ALS30ADR	SOIC	D	14	2500	356.0	356.0	35.0
SN74AS30DR	SOIC	D	14	2500	356.0	356.0	35.0

**TUBE**

\*All dimensions are nominal

Device	Package Name	Package Type	Pins	SPQ	L (mm)	W (mm)	T (μm)	B (mm)
5962-86837012A	FK	LCCC	20	55	506.98	12.06	2030	NA
5962-8683701DA	W	CFP	14	25	506.98	26.16	6220	NA
JM38510/37004B2A	FK	LCCC	20	55	506.98	12.06	2030	NA
M38510/37004B2A	FK	LCCC	20	55	506.98	12.06	2030	NA
SN74ALS30ADB	DB	SSOP	14	80	530	10.5	4000	4.1
SN74ALS30ADBE4	DB	SSOP	14	80	530	10.5	4000	4.1
SN74ALS30AN	N	PDIP	14	25	506	13.97	11230	4.32
SN74ALS30AN	N	PDIP	14	25	506	13.97	11230	4.32
SN74AS30N	N	PDIP	14	25	506	13.97	11230	4.32
SN74AS30N	N	PDIP	14	25	506	13.97	11230	4.32
SNJ54ALS30AFK	FK	LCCC	20	55	506.98	12.06	2030	NA
SNJ54ALS30AW	W	CFP	14	25	506.98	26.16	6220	NA

W (R-GDFP-F14)

CERAMIC DUAL FLATPACK



- NOTES:
- A. All linear dimensions are in inches (millimeters).
  - B. This drawing is subject to change without notice.
  - C. This package can be hermetically sealed with a ceramic lid using glass frit.
  - D. Index point is provided on cap for terminal identification only.
  - E. Falls within MIL STD 1835 GDFP1-F14

# DB0014A



# PACKAGE OUTLINE

## SSOP - 2 mm max height

SMALL OUTLINE PACKAGE

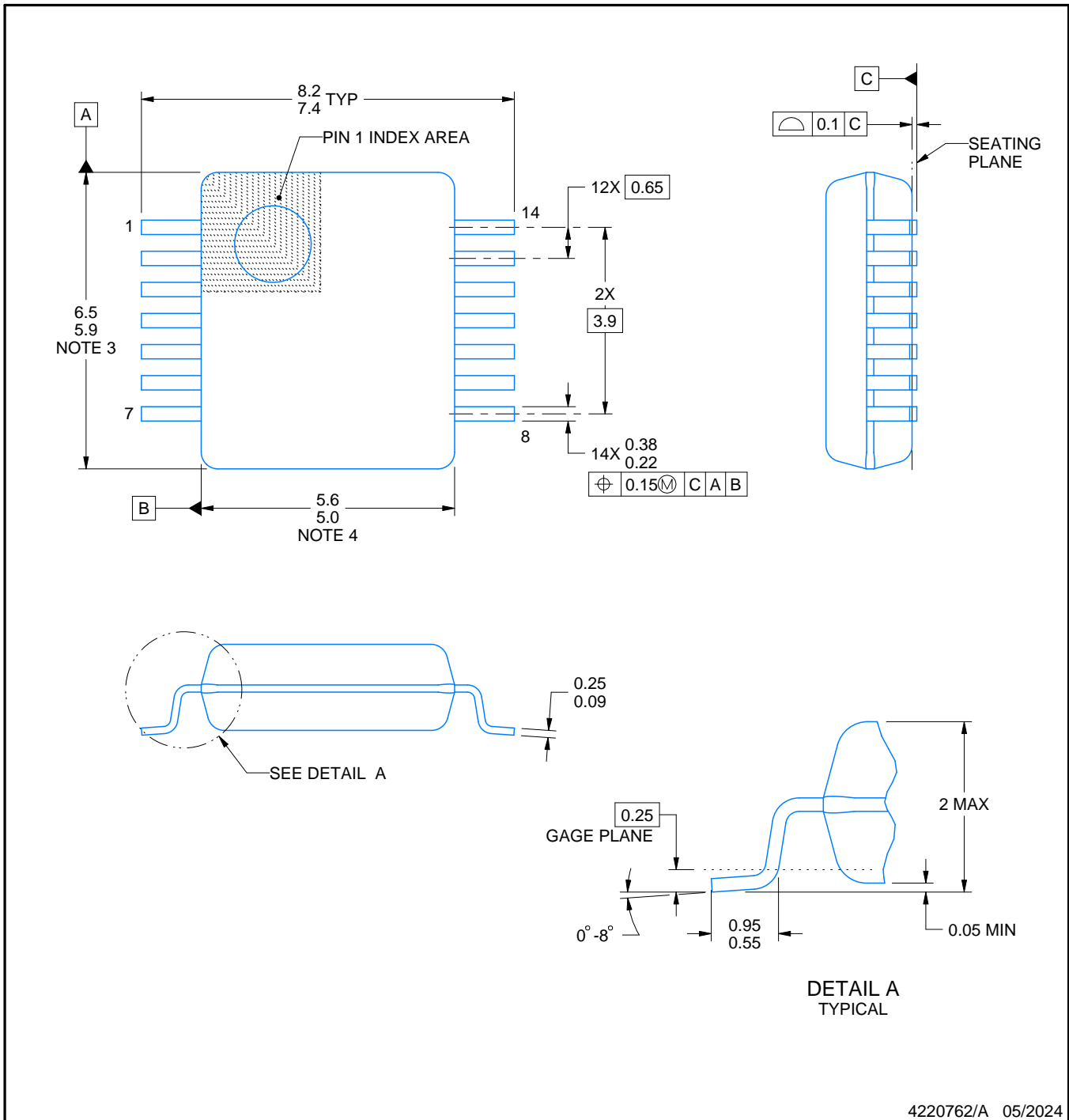

### NOTES:

1. All linear dimensions are in millimeters. Any dimensions in parenthesis are for reference only. Dimensioning and tolerancing per ASME Y14.5M.
2. This drawing is subject to change without notice.
3. This dimension does not include mold flash, protrusions, or gate burrs. Mold flash, protrusions, or gate burrs shall not exceed 0.15 mm per side.
4. Reference JEDEC registration MO-150.

# EXAMPLE BOARD LAYOUT

DB0014A

SSOP - 2 mm max height

SMALL OUTLINE PACKAGE

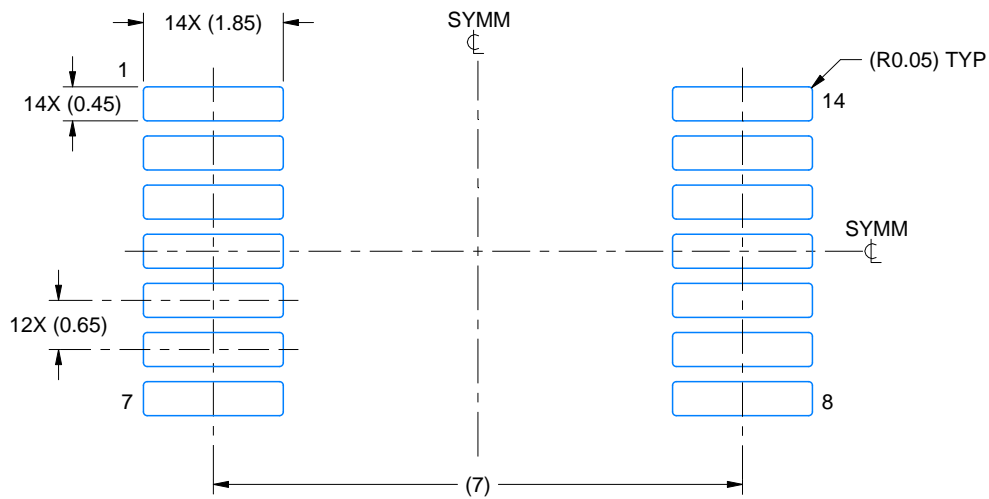

LAND PATTERN EXAMPLE  
EXPOSED METAL SHOWN  
SCALE: 10X

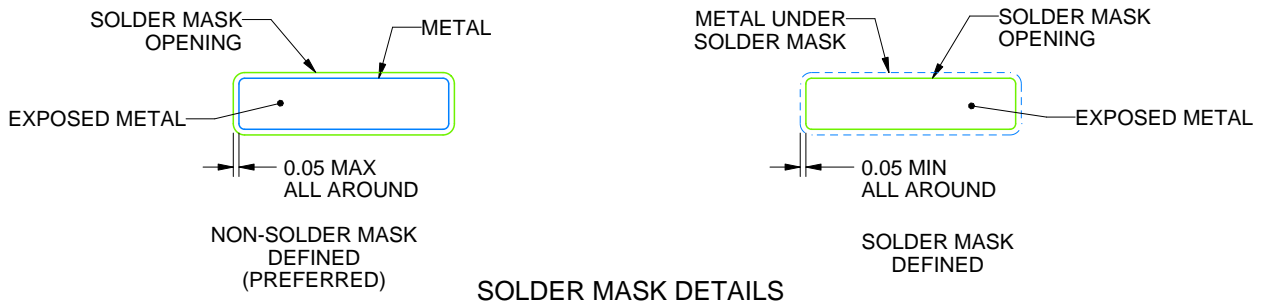

4220762/A 05/2024

NOTES: (continued)

- 5. Publication IPC-7351 may have alternate designs.
- 6. Solder mask tolerances between and around signal pads can vary based on board fabrication site.

# EXAMPLE STENCIL DESIGN

DB0014A

SSOP - 2 mm max height

SMALL OUTLINE PACKAGE

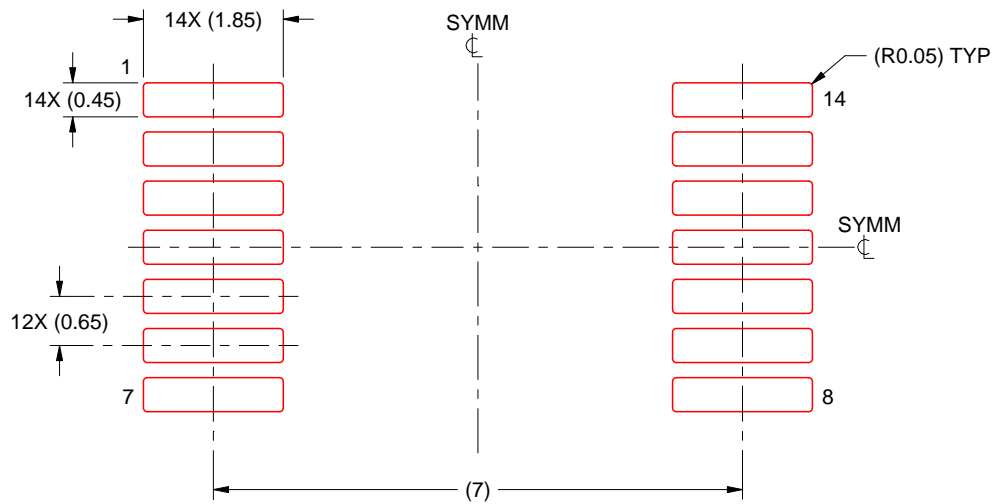

SOLDER PASTE EXAMPLE  
BASED ON 0.125 mm THICK STENCIL  
SCALE: 10X

4220762/A 05/2024

NOTES: (continued)

7. Laser cutting apertures with trapezoidal walls and rounded corners may offer better paste release. IPC-7525 may have alternate design recommendations.
8. Board assembly site may have different recommendations for stencil design.

## GENERIC PACKAGE VIEW

**FK 20**

**LCCC - 2.03 mm max height**

8.89 x 8.89, 1.27 mm pitch

LEADLESS CERAMIC CHIP CARRIER

This image is a representation of the package family, actual package may vary.  
Refer to the product data sheet for package details.



4229370VA\

J 14

**GENERIC PACKAGE VIEW**  
**CDIP - 5.08 mm max height**  
CERAMIC DUAL IN LINE PACKAGE



Images above are just a representation of the package family, actual package may vary.  
Refer to the product data sheet for package details.

4040083-5/G

J0014A



# PACKAGE OUTLINE

CDIP - 5.08 mm max height

CERAMIC DUAL IN LINE PACKAGE



4214771/A 05/2017

NOTES:

1. All controlling linear dimensions are in inches. Dimensions in brackets are in millimeters. Any dimension in brackets or parenthesis are for reference only. Dimensioning and tolerancing per ASME Y14.5M.
2. This drawing is subject to change without notice.
3. This package is hermetically sealed with a ceramic lid using glass frit.
4. Index point is provided on cap for terminal identification only and on press ceramic glass frit seal only.
5. Falls within MIL-STD-1835 and GDIP1-T14.

# EXAMPLE BOARD LAYOUT

J0014A

CDIP - 5.08 mm max height

CERAMIC DUAL IN LINE PACKAGE



LAND PATTERN EXAMPLE  
NON-SOLDER MASK DEFINED  
SCALE: 5X



4214771/A 05/2017



D (R-PDSO-G14)

PLASTIC SMALL OUTLINE



- NOTES:
- All linear dimensions are in millimeters.
  - This drawing is subject to change without notice.
  - Publication IPC-7351 is recommended for alternate designs.
  - Laser cutting apertures with trapezoidal walls and also rounding corners will offer better paste release. Customers should contact their board assembly site for stencil design recommendations. Refer to IPC-7525 for other stencil recommendations.
  - Customers should contact their board fabrication site for solder mask tolerances between and around signal pads.

N (R-PDIP-T\*\*)

PLASTIC DUAL-IN-LINE PACKAGE

16 PINS SHOWN



- NOTES:
- A. All linear dimensions are in inches (millimeters).
  - B. This drawing is subject to change without notice.
  - Falls within JEDEC MS-001, except 18 and 20 pin minimum body length (Dim A).
  - The 20 pin end lead shoulder width is a vendor option, either half or full width.

## IMPORTANT NOTICE AND DISCLAIMER

TI PROVIDES TECHNICAL AND RELIABILITY DATA (INCLUDING DATA SHEETS), DESIGN RESOURCES (INCLUDING REFERENCE DESIGNS), APPLICATION OR OTHER DESIGN ADVICE, WEB TOOLS, SAFETY INFORMATION, AND OTHER RESOURCES "AS IS" AND WITH ALL FAULTS, AND DISCLAIMS ALL WARRANTIES, EXPRESS AND IMPLIED, INCLUDING WITHOUT LIMITATION ANY IMPLIED WARRANTIES OF MERCHANTABILITY, FITNESS FOR A PARTICULAR PURPOSE OR NON-INFRINGEMENT OF THIRD PARTY INTELLECTUAL PROPERTY RIGHTS.

These resources are intended for skilled developers designing with TI products. You are solely responsible for (1) selecting the appropriate TI products for your application, (2) designing, validating and testing your application, and (3) ensuring your application meets applicable standards, and any other safety, security, regulatory or other requirements.

These resources are subject to change without notice. TI grants you permission to use these resources only for development of an application that uses the TI products described in the resource. Other reproduction and display of these resources is prohibited. No license is granted to any other TI intellectual property right or to any third party intellectual property right. TI disclaims responsibility for, and you will fully indemnify TI and its representatives against, any claims, damages, costs, losses, and liabilities arising out of your use of these resources.

TI's products are provided subject to [TI's Terms of Sale](#) or other applicable terms available either on [ti.com](https://www.ti.com) or provided in conjunction with such TI products. TI's provision of these resources does not expand or otherwise alter TI's applicable warranties or warranty disclaimers for TI products.

TI objects to and rejects any additional or different terms you may have proposed.

Mailing Address: Texas Instruments, Post Office Box 655303, Dallas, Texas 75265  
Copyright © 2024, Texas Instruments Incorporated

## Looking for pricing, stock, or lifecycle information?

Click below to explore more details on WIN SOURCE:

 [View SN74ALS30AD](#) on WIN SOURCE

 [Texas Instruments](#) Information

## Optimize Your Supply Chain with WIN SOURCE Solutions

-  Global Sourcing Solution
-  Obsolete Management
-  Cost Control Management
-  Shortage Management
-  Alternative Solution
-  Excess Inventory Management