



**THE DATASHEET OF  
CY8CLED04-68LFXI**



## Features

- HB LED Controller
  - Configurable dimmers support up to four independent LED channels
  - 8- to 32-bits of resolution per channel
  - Dynamic reconfiguration enables led controller plus other features: CapSense®, Battery Charging, and Motor Control
- Visual embedded design
  - LED-Based drivers
    - Binning compensation
    - Temperature feedback
    - Optical feedback
    - DMX512
- PrISM™ modulation technology
  - Reduces radiated EMI
  - Reduces low frequency blinking
- Advanced peripherals (PSoC® blocks)
  - Four digital PSoC blocks provide:
    - 8 to 32-bit timers, counters, and PWMs
    - Full-duplex UART
    - Multiple SPI Masters or Slaves
    - Connectable to all GPIO pins
  - Six Rail-to-Rail analog PSoC blocks provide:
    - Up to 14-bit ADCs
    - Up to 9-bit DACs
    - Programmable gain amplifiers (PGA)
    - Programmable filters and comparators
  - Complex peripherals by combining blocks
  - Capacitive sensing application capability
- Complete development tools
  - Free development software
    - PSoC Designer™
  - Full featured, in-circuit emulator (ICE) and programmer
  - Full speed emulation
  - Complex breakpoint structure
  - 128 KB trace memory
- Programmable pin configurations
  - 25 mA sink, 10 mA source on all GPIO
  - Pull-up, pull-down, high Z, strong, or open drain drive modes on all GPIO
  - Up to 12 analog inputs on GPIO
  - Four 30 mA analog outputs on GPIO
  - Configurable interrupt on all GPIO
- Flexible on-chip memory
  - 16K flash program storage 50,000 erase/write cycles
  - 1K SRAM data storage
  - In-system serial programming (ISSP)
  - Partial flash updates
  - Flexible protection modes
  - EEPROM emulation in flash
- Full speed USB (12 Mbps)
  - Four uni-directional endpoints
  - One bi-directional control endpoint
  - USB 2.0 compliant
  - Dedicated 256 byte buffer
  - No external crystal required

### Logic Block Diagram

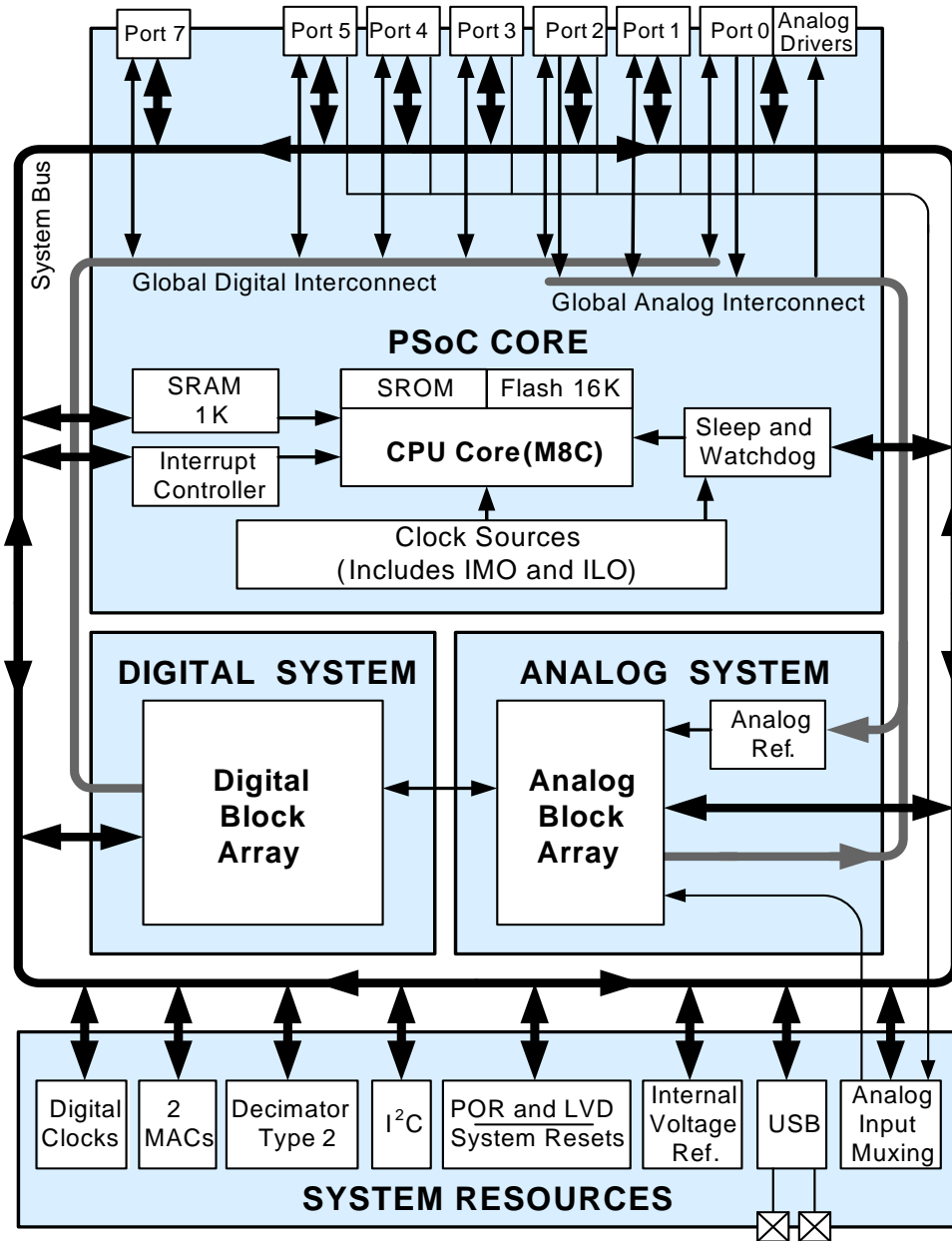

**Contents**

<b>EZ-Color™ Functional Overview</b> .....	<b>4</b>	<b>Packaging Information</b> .....	<b>37</b>
Target Applications .....	4	Thermal Impedance .....	38
The PSoC Core .....	4	Solder Reflow Peak Temperature .....	38
The Digital System .....	4	<b>Development Tools</b> .....	<b>39</b>
The Analog System .....	5	Software .....	39
The Analog Multiplexer System .....	6	Evaluation Tools .....	39
Additional System Resources .....	6	Device Programmers .....	40
EZ-Color Device Characteristics .....	6	Accessories (Emulation and Programming) .....	40
<b>Getting Started</b> .....	<b>7</b>	Third Party Tools .....	40
Application Notes .....	7	Build a PSoC Emulator into Your Board .....	40
Development Kits .....	7	<b>Ordering Information</b> .....	<b>41</b>
Training .....	7	Key Device Features .....	41
CYPros Consultants .....	7	Ordering Code Definitions .....	41
Solutions Library .....	7	<b>Acronyms</b> .....	<b>42</b>
Technical Support .....	7	Acronyms Used .....	42
<b>Development Tools</b> .....	<b>7</b>	<b>Reference Documents</b> .....	<b>42</b>
PSoC Designer Software Subsystems .....	7	<b>Document Conventions</b> .....	<b>43</b>
<b>Designing with PSoC Designer</b> .....	<b>9</b>	Units of Measure .....	43
Select User Modules .....	9	Numeric Conventions .....	43
Configure User Modules .....	9	<b>Glossary</b> .....	<b>43</b>
Organize and Connect .....	9	<b>Document History Page</b> .....	<b>48</b>
Generate, Verify, and Debug .....	9	<b>Sales, Solutions, and Legal Information</b> .....	<b>49</b>
<b>Pin Information</b> .....	<b>10</b>	Worldwide Sales and Design Support .....	49
68-Pin Part Pinout .....	10	Products .....	49
<b>Register Conventions</b> .....	<b>11</b>	PSoC® Solutions .....	49
Abbreviations Used .....	11		
Register Mapping Tables .....	11		
<b>Electrical Specifications</b> .....	<b>14</b>		
Absolute Maximum Ratings .....	15		
Operating Temperature .....	15		
DC Electrical Characteristics .....	16		
AC Electrical Characteristics .....	29		

## EZ-Color™ Functional Overview

Cypress's EZ-Color family of devices offers the ideal control solution for high brightness LED applications requiring intelligent dimming control. EZ-Color devices combine the power and flexibility of Programmable System-on-Chip (PSoC®); with Cypress's precise illumination signal modulation (PrISM™) modulation technology providing lighting designers a fully customizable and integrated lighting solution platform.

The EZ-Color family supports a range of independent LED channels from 4 channels at 32 bits of resolution each, up to 16 channels at 8 bits of resolution each. This enables lighting designers the flexibility to choose the LED array size and color quality. PSoC Designer software, with lighting specific drivers, can significantly cut development time and simplify implementation of fixed color points through temperature, optical, and LED binning compensation. EZ-Color's virtually limitless analog and digital customization enable simple integration of features in addition to intelligent lighting, such as CapSense, battery charging, image stabilization, and motor control during the development process. These features, along with Cypress's best-in-class quality and design support, make EZ-Color the ideal choice for intelligent HB LED control applications.

### Target Applications

- LCD Backlight
- Large Signs
- General Lighting
- Architectural Lighting
- Camera/Cell Phone Flash
- Flashlights

### The PSoC Core

The PSoC Core is a powerful engine that supports a rich feature set. The core includes a CPU, memory, clocks, and configurable General Purpose I/O (GPIO).

The M8C CPU core is a powerful processor with speeds up to 68 MHz, providing a four MIPS 8-bit Harvard-architecture microprocessor. The CPU uses an interrupt controller with up to 20 vectors, to simplify programming of real time embedded events. Program execution is timed and protected using the included Sleep and watchdog timers (WDT).

Memory encompasses 16K of flash for program storage, 1K of SRAM for data storage, and up to 2K of EEPROM emulated using the flash. Program flash uses four protection levels on blocks of 64 bytes, allowing customized software IP protection.

The EZ-Color family incorporates flexible internal clock generators, including a 24 MHz internal main oscillator (IMO) accurate to 8 percent over temperature and voltage. The 24 MHz IMO can also be doubled to 48 MHz for use by the digital system. A low power 32 kHz internal low speed oscillator (ILO) is provided for the sleep timer and WDT. The clocks, together with programmable clock dividers (as a system resource), provide the flexibility to integrate almost any timing requirement into the EZ-Color device. In USB systems, the IMO self-tunes to ± 0.25% accuracy for USB communication.

EZ-Color GPIOs provide connection to the CPU, digital and analog resources of the device. Each pin's drive mode may be selected from eight options, allowing great flexibility in external interfacing. Every pin can also generate a system interrupt on high level, low level, and change from last read.

### The Digital System

The digital system is composed of four digital PSoC blocks. Each block is an 8-bit resource that can be used alone or combined with other blocks to form 8-, 16-, 24-, and 32-bit peripherals, which are called user module references.

Digital peripheral configurations include:

- PrISM (8- to 32-bit)
- Full speed USB (12 Mbps)
- PWMs (8- to 32-bit)
- PWMs with Dead band (8- to 24-bit)
- Counters (8- to 32-bit)
- Timers (8- to 32-bit)
- UART 8-bit with selectable parity
- SPI master and slave
- I<sup>2</sup>C slave and multi-master
- Cyclical Redundancy Checker (CRC)/Generator (8- to 32-bit)
- IrDA
- Generators (8- to 32-bit)

The digital blocks can be connected to any GPIO through a series of global buses that can route any signal to any pin. The buses also allow for signal multiplexing and for performing logic operations. This configurability frees your designs from the constraints of a fixed peripheral controller.

Digital blocks are provided in rows of four, where the number of blocks varies by EZ-Color device family. This allows you the optimum choice of system resources for your application. Family resources are shown in the table titled EZ-Color Device Characteristics.

Figure 1. Digital System Block Diagram

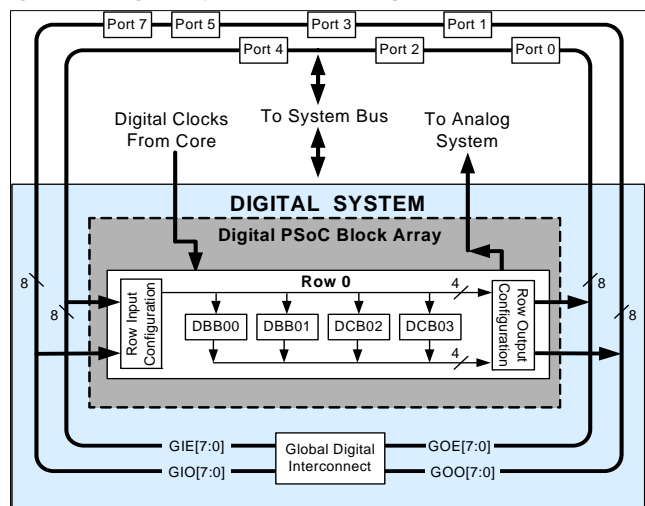

### The Analog System

The Analog System is composed of six configurable blocks, each comprised of an opamp circuit allowing the creation of complex analog signal flows. Analog peripherals are very flexible and can be customized to support specific application requirements. Some of the more common EZ-Color analog functions (most available as user modules) are listed below.

- Analog-to-digital converters (up to 2, with 6- to 14-bit resolution, selectable as Incremental, Delta Sigma, and SAR)
- Filters (2 and 4 pole band-pass, low-pass, and notch)
- Amplifiers (up to 2, with selectable gain to 48x)
- Instrumentation amplifiers (1 with selectable gain to 93x)
- Comparators (up to 2, with 16 selectable thresholds)
- DACs (up to 2, with 6- to 9-bit resolution)
- Multiplying DACs (up to 2, with 6- to 9-bit resolution)
- High current output drivers (two with 30 mA drive as a PSoC Core Resource)
- 1.3-V reference (as a system resource)
- DTMF Dialer
- Modulators
- Correlators
- Peak detectors
- Many other topologies possible

Analog blocks are arranged in a column of three, which includes one Continuous Time (CT) and two Switched Capacitor (SC) blocks, as shown in the figure below.

Figure 2. Analog System Block Diagram

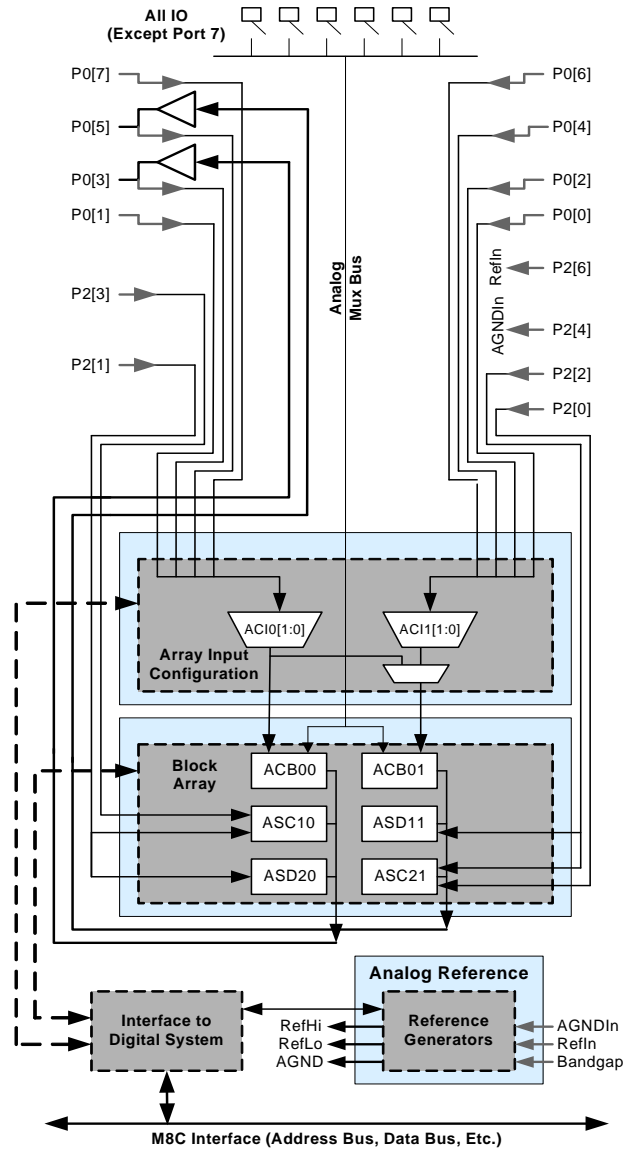

**The Analog Multiplexer System**

The Analog Mux Bus can connect to every GPIO pin in ports 0-5. Pins can be connected to the bus individually or in any combination. The bus also connects to the analog system for analysis with comparators and analog-to-digital converters. It can be split into two sections for simultaneous dual-channel processing. An additional 8:1 analog input multiplexer provides a second path to bring Port 0 pins to the analog array.

Switch control logic enables selected pins to precharge continuously under hardware control. This enables capacitive measurement for applications such as touch sensing. Other multiplexer applications include:

- Track pad, finger sensing.
- Chip-wide mux that allows analog input from up to 48 I/O pins.
- Crosspoint connection between any I/O pin combinations.

When designing capacitive sensing applications, refer to the latest signal-to-noise signal level requirements Application Notes, which can be found under <http://www.cypress.com> > Documentation. In general, and unless otherwise noted in the relevant Application Notes, the minimum signal-to-noise ratio (SNR) for CapSense applications is 5:1.

**Additional System Resources**

System resources, provide additional capability useful to complete systems. Additional resources include a multiplier, decimator, low voltage detection, and power on reset. Brief statements describing the merits of each resource follow.

- Full-speed USB (12 Mbps) with 5 configurable endpoints and 256 bytes of RAM. No external components required except two series resistors. Wider than commercial temperature USB operation (–10 °C to +85 °C).
- Digital clock dividers provide three customizable clock frequencies for use in applications. The clocks can be routed to both the digital and analog systems. Additional clocks can be generated using digital PSoC blocks as clock dividers.
- Two multiply accumulates (MACs) provide fast 8-bit multipliers with 32-bit accumulate, to assist in both general math as well as digital filters.
- Decimator provides a custom hardware filter for digital signal processing apps. including creation of Delta Sigma ADCs.
- The I<sup>2</sup>C module provides 100- and 400-kHz communication over two wires. Slave, master, multi-master are supported.
- Low-voltage detect (LVD) interrupts signal the application of falling voltage levels, while the advanced Power-on reset (POR) circuit eliminates the need for a system supervisor.
- An internal 1.3-V reference provides an absolute reference for the analog system, including ADCs and DACs.
- Versatile analog multiplexer system.

**EZ-Color Device Characteristics**

Depending on your EZ-Color device characteristics, the digital and analog systems can have 16, 8, or 4 digital blocks and 12, 6, or 4 analog blocks. The following table lists the resources available for specific EZ-Color device groups. The device covered by this data sheet is shown in the highlighted row of the table

**Table 1. EZ-Color Device Characteristics**

PSoC Part Number	LED Channels	Digital I/O	Digital Rows	Digital Blocks	Analog Inputs	Analog Outputs	Analog Columns	Analog Blocks	SRAM Size	Flash Size	CapSense
CY8CLED02	2	16	1	4	8	0	2	4	256 Bytes	4K	No
CY8CLED04	4	56	1	4	48	2	2	6	1K	16K	Yes
CY8CLED08	8	44	2	8	12	4	4	12	256 Bytes	16K	No
CY8CLED16	16	44	4	16	12	4	4	12	2K	32K	No

## Getting Started

The quickest way to understand PSoC silicon is to read this data sheet and then use the PSoC Designer integrated development environment (IDE). This data sheet is an overview of the PSoC integrated circuit and presents specific pin, register, and electrical specifications.

For in depth information, along with detailed programming details, see the [PSoC® Programmable System-on-Chip Technical Reference Manual](#).

For up-to-date ordering, packaging, and electrical specification information, see the latest PSoC device data sheets on the web at <http://www.cypress.com/ez-color>.

## Application Notes

[Cypress application notes](#) are an excellent introduction to the wide variety of possible PSoC designs.

## Development Kits

[PSoC Development Kits](#) are available online from and through a growing number of regional and global distributors, which include Arrow, Avnet, Digi-Key, Farnell, Future Electronics, and Newark.

## Training

[Free PSoC technical training](#) (on demand, webinars, and workshops), which is available online via [www.cypress.com](http://www.cypress.com), covers a wide variety of topics and skill levels to assist you in your designs.

## CYPros Consultants

Certified PSoC consultants offer everything from technical assistance to completed PSoC designs. To contact or become a PSoC consultant go to the [CYPros Consultants](#) web site.

## Solutions Library

Visit our growing [library of solution focused designs](#). Here you can find various application designs that include firmware and hardware design files that enable you to complete your designs quickly.

## Technical Support

[Technical support](#) – including a searchable Knowledge Base articles and technical forums – is also available online. If you cannot find an answer to your question, call our Technical Support hotline at 1-800-541-4736.

## Development Tools

PSoC Designer™ is the revolutionary integrated design environment (IDE) that you can use to customize PSoC to meet your specific application requirements. PSoC Designer software accelerates system design and time to market. Develop your applications using a library of precharacterized analog and digital peripherals (called user modules) in a drag-and-drop design environment. Then, customize your design by leveraging the dynamically generated application programming interface (API) libraries of code. Finally, debug and test your designs with the integrated debug environment, including in-circuit emulation and standard software debug features. PSoC Designer includes:

- Application editor graphical user interface (GUI) for device and user module configuration and dynamic reconfiguration
- Extensive user module catalog
- Integrated source-code editor (C and assembly)
- Free C compiler with no size restrictions or time limits
- Built-in debugger
- In-circuit emulation
- Built-in support for communication interfaces:
  - Hardware and software I<sup>2</sup>C slaves and masters
  - Full-speed USB 2.0
  - Up to four full-duplex universal asynchronous receiver/transmitters (UARTs), SPI master and slave, and wireless

PSoC Designer supports the entire library of PSoC 1 devices and runs on Windows XP, Windows Vista, and Windows 7.

## PSoC Designer Software Subsystems

### *Design Entry*

In the chip-level view, choose a base device to work with. Then select different onboard analog and digital components that use the PSoC blocks, which are called user modules. Examples of user modules are analog-to-digital converters (ADCs), digital-to-analog converters (DACs), amplifiers, and filters. Configure the user modules for your chosen application and connect them to each other and to the proper pins. Then generate your project. This prepopulates your project with APIs and libraries that you can use to program your application.

The tool also supports easy development of multiple configurations and dynamic reconfiguration. Dynamic reconfiguration makes it possible to change configurations at run time. In essence, this lets you to use more than 100 percent of PSoC's resources for an application.

### *Code Generation Tools*

The code generation tools work seamlessly within the PSoC Designer interface and have been tested with a full range of debugging tools. You can develop your design in C, assembly, or a combination of the two.

**Assemblers.** The assemblers allow you to merge assembly code seamlessly with C code. Link libraries automatically use absolute addressing or are compiled in relative mode, and linked with other software modules to get absolute addressing.

**C Language Compilers.** C language compilers are available that support the PSoC family of devices. The products allow you to create complete C programs for the PSoC family devices. The optimizing C compilers provide all of the features of C, tailored to the PSoC architecture. They come complete with embedded libraries providing port and bus operations, standard keypad and display support, and extended math functionality.

### *Debugger*

PSoC Designer has a debug environment that provides hardware in-circuit emulation, allowing you to test the program in a physical system while providing an internal view of the PSoC device. Debugger commands allow you to read and program and read and write data memory, and read and write I/O registers.

You can read and write CPU registers, set and clear breakpoints, and provide program run, halt, and step control. The debugger also lets you to create a trace buffer of registers and memory locations of interest.

### *Online Help System*

The online help system displays online, context-sensitive help. Designed for procedural and quick reference, each functional subsystem has its own context-sensitive help. This system also provides tutorials and links to FAQs and an Online Support Forum to aid the designer.

### *In-Circuit Emulator*

A low-cost, high-functionality in-circuit emulator (ICE) is available for development support. This hardware can program single devices.

The emulator consists of a base unit that connects to the PC using a USB port. The base unit is universal and operates with all PSoC devices. Emulation pods for each device family are available separately. The emulation pod takes the place of the PSoC device in the target board and performs full-speed (24 MHz) operation.

## Designing with PSoC Designer

The development process for the PSoC device differs from that of a traditional fixed-function microprocessor. The configurable analog and digital hardware blocks give the PSoC architecture a unique flexibility that pays dividends in managing specification change during development and lowering inventory costs. These configurable resources, called PSoC blocks, have the ability to implement a wide variety of user-selectable functions. The PSoC development process is:

1. Select [user modules](#).
2. Configure user modules.
3. Organize and connect.
4. Generate, verify, and debug.

### Select User Modules

PSoC Designer provides a library of prebuilt, pretested hardware peripheral components called “user modules.” User modules make selecting and implementing peripheral devices, both analog and digital, simple.

### Configure User Modules

Each user module that you select establishes the basic register settings that implement the selected function. They also provide parameters and properties that allow you to tailor their precise configuration to your particular application. For example, a PWM User Module configures one or more digital PSoC blocks, one for each eight bits of resolution. Using these parameters, you can establish the pulse width and duty cycle. Configure the parameters and properties to correspond to your chosen application. Enter values directly or by selecting values from drop-down menus. All of the user modules are documented in datasheets that may be viewed directly in PSoC Designer or on the Cypress website. These [user module datasheets](#) explain the internal operation of the user module and provide performance specifications. Each datasheet describes the use of each user module parameter, and other information that you may need to successfully implement your design.

### Organize and Connect

Build signal chains at the chip level by interconnecting user modules to each other and the I/O pins. Perform the selection, configuration, and routing so that you have complete control over all on-chip resources.

### Generate, Verify, and Debug

When you are ready to test the hardware configuration or move on to developing code for the project, perform the “Generate Configuration Files” step. This causes PSoC Designer to generate source code that automatically configures the device to your specification and provides the software for the system. The generated code provides APIs with high-level functions to control and respond to hardware events at run time, and interrupt service routines that you can adapt as needed.

A complete code development environment lets you to develop and customize your applications in C, assembly language, or both.

The last step in the development process takes place inside PSoC Designer’s Debugger (accessed by clicking the Connect icon). PSoC Designer downloads the HEX image to the ICE where it runs at full-speed. PSoC Designer debugging capabilities rival those of systems costing many times more. In addition to traditional single-step, run-to-breakpoint, and watch-variable features, the debug interface provides a large trace buffer. It lets you to define complex breakpoint events that include monitoring address and data bus values, memory locations, and external signals.



## Register Conventions

This section lists the registers of the CY8CLED04 EZ-Color device.

### Abbreviations Used

The register conventions specific to this section are listed in the following table.

Convention	Description
R	Read register or bit(s)
W	Write register or bit(s)
L	Logical register or bit(s)
C	Clearable register or bit(s)
#	Access is bit specific

### Register Mapping Tables

The device has a total register address space of 512 bytes. The register space is referred to as I/O space and is divided into two banks., Bank 0 and Bank 1. The XO1 bit in the Flag register (CPU\_F) determines which bank the user is currently in. When the XO1 bit is set to 1, the user is in Bank 1.

**Note** In the following register mapping tables, blank fields are Reserved and should not be accessed.

**Table 3. Register Map Bank 0 Table: User Space**

Name	Addr (0,Hex)	Access	Name	Addr (0,Hex)	Access	Name	Addr (0,Hex)	Access	Name	Addr (0,Hex)	Access
PRT0DR	00	RW	PMA0_DR	40	RW	ASC10CR0	80	RW		C0	
PRT0IE	01	RW	PMA1_DR	41	RW	ASC10CR1	81	RW		C1	
PRT0GS	02	RW	PMA2_DR	42	RW	ASC10CR2	82	RW		C2	
PRT0DM2	03	RW	PMA3_DR	43	RW	ASC10CR3	83	RW		C3	
PRT1DR	04	RW	PMA4_DR	44	RW	ASD11CR0	84	RW		C4	
PRT1IE	05	RW	PMA5_DR	45	RW	ASD11CR1	85	RW		C5	
PRT1GS	06	RW	PMA6_DR	46	RW	ASD11CR2	86	RW		C6	
PRT1DM2	07	RW	PMA7_DR	47	RW	ASD11CR3	87	RW		C7	
PRT2DR	08	RW	USB_SOF0	48	R		88			C8	
PRT2IE	09	RW	USB_SOF1	49	R		89			C9	
PRT2GS	0A	RW	USB_CR0	4A	RW		8A			CA	
PRT2DM2	0B	RW	USB/O_CR 0	4B	#		8B			CB	
PRT3DR	0C	RW	USB/O_CR 1	4C	RW		8C			CC	
PRT3IE	0D	RW		4D			8D			CD	
PRT3GS	0E	RW	EP1_CNT1	4E	#		8E			CE	
PRT3DM2	0F	RW	EP1_CNT	4F	RW		8F			CF	
PRT4DR	10	RW	EP2_CNT1	50	#	ASD20CR0	90	RW	CUR_PP	D0	RW
PRT4IE	11	RW	EP2_CNT	51	RW	ASD20CR1	91	RW	STK_PP	D1	RW
PRT4GS	12	RW	EP3_CNT1	52	#	ASD20CR2	92	RW		D2	
PRT4DM2	13	RW	EP3_CNT	53	RW	ASD20CR3	93	RW	IDX_PP	D3	RW
PRT5DR	14	RW	EP4_CNT1	54	#	ASC21CR0	94	RW	MVR_PP	D4	RW
PRT5IE	15	RW	EP4_CNT	55	RW	ASC21CR1	95	RW	MVV_PP	D5	RW
PRT5GS	16	RW	EP0_CR	56	#	ASC21CR2	96	RW	I2C_CFG	D6	RW
PRT5DM2	17	RW	EP0_CNT	57	#	ASC21CR3	97	RW	I2C_SCR	D7	#
	18		EP0_DR0	58	RW		98		I2C_DR	D8	RW
	19		EP0_DR1	59	RW		99		I2C_MSCR	D9	#
	1A		EP0_DR2	5A	RW		9A		INT_CLR0	DA	RW
	1B		EP0_DR3	5B	RW		9B		INT_CLR1	DB	RW
PRT7DR	1C	RW	EP0_DR4	5C	RW		9C		INT_CLR2	DC	RW
PRT7IE	1D	RW	EP0_DR5	5D	RW		9D		INT_CLR3	DD	RW
PRT7GS	1E	RW	EP0_DR6	5E	RW		9E		INT_MSK3	DE	RW
PRT7DM2	1F	RW	EP0_DR7	5F	RW		9F		INT_MSK2	DF	RW
DBB00DR0	20	#	AMX_IN	60	RW		A0		INT_MSK0	E0	RW
DBB00DR1	21	W	AMUXCFG	61	RW		A1		INT_MSK1	E1	RW

Blank fields are Reserved and should not be accessed.

# Access is bit specific.

**Table 3. Register Map Bank 0 Table: User Space (continued)**

Name	Addr (0,Hex)	Access	Name	Addr (0,Hex)	Access	Name	Addr (0,Hex)	Access	Name	Addr (0,Hex)	Access
DBB00DR2	22	RW		62			A2		INT_VC	E2	RC
DBB00CR0	23	#	ARF_CR	63	RW		A3		RES_WDT	E3	W
DBB01DR0	24	#	CMP_CR0	64	#		A4		DEC_DH	E4	RC
DBB01DR1	25	W	ASY_CR	65	#		A5		DEC_DL	E5	RC
DBB01DR2	26	RW	CMP_CR1	66	RW		A6		DEC_CR0	E6	RW
DBB01CR0	27	#		67			A7		DEC_CR1	E7	RW
DCB02DR0	28	#		68		MUL1_X	A8	W	MUL0_X	E8	W
DCB02DR1	29	W		69		MUL1_Y	A9	W	MUL0_Y	E9	W
DCB02DR2	2A	RW		6A		MUL1_DH	AA	R	MUL0_DH	EA	R
DCB02CR0	2B	#		6B		MUL1_DL	AB	R	MUL0_DL	EB	R
DCB03DR0	2C	#	TMP_DR0	6C	RW	ACC1_DR1	AC	RW	ACC0_DR1	EC	RW
DCB03DR1	2D	W	TMP_DR1	6D	RW	ACC1_DR0	AD	RW	ACC0_DR0	ED	RW
DCB03DR2	2E	RW	TMP_DR2	6E	RW	ACC1_DR3	AE	RW	ACC0_DR3	EE	RW
DCB03CR0	2F	#	TMP_DR3	6F	RW	ACC1_DR2	AF	RW	ACC0_DR2	EF	RW
	30		ACB00CR3	70	RW	RDIOI	B0	RW		F0	
	31		ACB00CR0	71	RW	RDIOISYN	B1	RW		F1	
	32		ACB00CR1	72	RW	RDIOIS	B2	RW		F2	
	33		ACB00CR2	73	RW	RDIOILT0	B3	RW		F3	
	34		ACB01CR3	74	RW	RDIOILT1	B4	RW		F4	
	35		ACB01CR0	75	RW	RDIOORO0	B5	RW		F5	
	36		ACB01CR1	76	RW	RDIOORO1	B6	RW		F6	
	37		ACB01CR2	77	RW		B7		CPU_F	F7	RL
	38			78			B8			F8	
	39			79			B9			F9	
	3A			7A			BA			FA	
	3B			7B			BB			FB	
	3C			7C			BC			FC	
	3D			7D			BD		DAC_D	FD	RW
	3E			7E			BE		CPU_SCR1	FE	#
	3F			7F			BF		CPU_SCR0	FF	#

Blank fields are Reserved and should not be accessed.

# Access is bit specific.

**Table 4. Register Map Bank 1 Table: Configuration Space**

Name	Addr (1,Hex)	Access	Name	Addr (1,Hex)	Access	Name	Addr (1,Hex)	Access	Name	Addr (1,Hex)	Access
PRT0DM0	00	RW	PMA0_WA	40	RW	ASC10CR0	80	RW	USBI/O_CR2	C0	RW
PRT0DM1	01	RW	PMA1_WA	41	RW	ASC10CR1	81	RW	USB_CR1	C1	#
PRT0IC0	02	RW	PMA2_WA	42	RW	ASC10CR2	82	RW			
PRT0IC1	03	RW	PMA3_WA	43	RW	ASC10CR3	83	RW			
PRT1DM0	04	RW	PMA4_WA	44	RW	ASD11CR0	84	RW	EP1_CR0	C4	#
PRT1DM1	05	RW	PMA5_WA	45	RW	ASD11CR1	85	RW	EP2_CR0	C5	#
PRT1IC0	06	RW	PMA6_WA	46	RW	ASD11CR2	86	RW	EP3_CR0	C6	#
PRT1IC1	07	RW	PMA7_WA	47	RW	ASD11CR3	87	RW	EP4_CR0	C7	#
PRT2DM0	08	RW		48			88			C8	
PRT2DM1	09	RW		49			89			C9	
PRT2IC0	0A	RW		4A			8A			CA	
PRT2IC1	0B	RW		4B			8B			CB	
PRT3DM0	0C	RW		4C			8C			CC	
PRT3DM1	0D	RW		4D			8D			CD	
PRT3IC0	0E	RW		4E			8E			CE	
PRT3IC1	0F	RW		4F			8F			CF	
PRT4DM0	10	RW	PMA0_RA	50	RW		90		GDI_O_IN	D0	RW

Blank fields are Reserved and should not be accessed.

# Access is bit specific.

**Table 4. Register Map Bank 1 Table: Configuration Space (continued)**

Name	Addr (1,Hex)	Access	Name	Addr (1,Hex)	Access	Name	Addr (1,Hex)	Access	Name	Addr (1,Hex)	Access
PRT4DM1	11	RW	PMA1_RA	51	RW	ASD20CR1	91	RW	GDI_E_IN	D1	RW
PRT4IC0	12	RW	PMA2_RA	52	RW	ASD20CR2	92	RW	GDI_O_OU	D2	RW
PRT4IC1	13	RW	PMA3_RA	53	RW	ASD20CR3	93	RW	GDI_E_OU	D3	RW
PRT5DM0	14	RW	PMA4_RA	54	RW	ASC21CR0	94	RW		D4	
PRT5DM1	15	RW	PMA5_RA	55	RW	ASC21CR1	95	RW		D5	
PRT5IC0	16	RW	PMA6_RA	56	RW	ASC21CR2	96	RW		D6	
PRT5IC1	17	RW	PMA7_RA	57	RW	ASC21CR3	97	RW		D7	
	18			58			98		MUX_CR0	D8	RW
	19			59			99		MUX_CR1	D9	RW
	1A			5A			9A		MUX_CR2	DA	RW
	1B			5B			9B		MUX_CR3	DB	RW
PRT7DM0	1C	RW		5C			9C			DC	
PRT7DM1	1D	RW		5D			9D		OSC_GO_EN	DD	RW
PRT7IC0	1E	RW		5E			9E		OSC_CR4	DE	RW
PRT7IC1	1F	RW		5F			9F		OSC_CR3	DF	RW
DBB00FN	20	RW	CLK_CR0	60	RW		A0		OSC_CR0	E0	RW
DBB00IN	21	RW	CLK_CR1	61	RW		A1		OSC_CR1	E1	RW
DBB00OU	22	RW	ABF_CR0	62	RW		A2		OSC_CR2	E2	RW
	23		AMD_CR0	63	RW		A3		VLT_CR	E3	RW
DBB01FN	24	RW	CMP_GO_EN	64	RW		A4		VLT_CMP	E4	R
DBB01IN	25	RW	CMP_GO_EN1	65	RW		A5			E5	
DBB01OU	26	RW	AMD_CR1	66	RW		A6			E6	
	27		ALT_CR0	67	RW		A7			E7	
DCB02FN	28	RW		68			A8		IMO_TR	E8	W
DCB02IN	29	RW		69			A9		ILO_TR	E9	W
DCB02OU	2A	RW		6A			AA		BDG_TR	EA	RW
	2B			6B			AB		ECO_TR	EB	W
DCB03FN	2C	RW	TMP_DR0	6C	RW		AC		MUX_CR4	EC	RW
DCB03IN	2D	RW	TMP_DR1	6D	RW		AD		MUX_CR5	ED	RW
DCB03OU	2E	RW	TMP_DR2	6E	RW		AE			EE	
	2F		TMP_DR3	6F	RW		AF			EF	
	30		ACB00CR3	70	RW	RDI0RI	B0	RW		F0	
	31		ACB00CR0	71	RW	RDI0SYN	B1	RW		F1	
	32		ACB00CR1	72	RW	RDI0IS	B2	RW		F2	
	33		ACB00CR2	73	RW	RDI0LT0	B3	RW		F3	
	34		ACB01CR3	74	RW	RDI0LT1	B4	RW		F4	
	35		ACB01CR0	75	RW	RDI0RO0	B5	RW		F5	
	36		ACB01CR1	76	RW	RDI0RO1	B6	RW		F6	
	37		ACB01CR2	77	RW		B7		CPU_F	F7	RL
	38			78			B8			F8	
	39			79			B9			F9	
	3A			7A			BA			FA	
	3B			7B			BB			FB	
	3C			7C			BC			FC	
	3D			7D			BD		DAC_CR	FD	RW
	3E			7E			BE		CPU_SCR1	FE	#
	3F			7F			BF		CPU_SCR0	FF	#

Blank fields are Reserved and should not be accessed.

# Access is bit specific.

### Electrical Specifications

This section presents the DC and AC electrical specifications of the CY8CLED04 EZ-Color device. For the most up to date electrical specifications, confirm that you have the most recent data sheet by going to the web at <http://www.cypress.com/ez-color>.

Specifications are valid for  $-40\text{ }^{\circ}\text{C} \leq T_A \leq 85\text{ }^{\circ}\text{C}$  and  $T_J \leq 100\text{ }^{\circ}\text{C}$ , except where noted. Specifications for devices running at greater than 12 MHz are valid for  $-40\text{ }^{\circ}\text{C} \leq T_A \leq 70\text{ }^{\circ}\text{C}$  and  $T_J \leq 82\text{ }^{\circ}\text{C}$ .

**Figure 4. Voltage versus CPU Frequency**

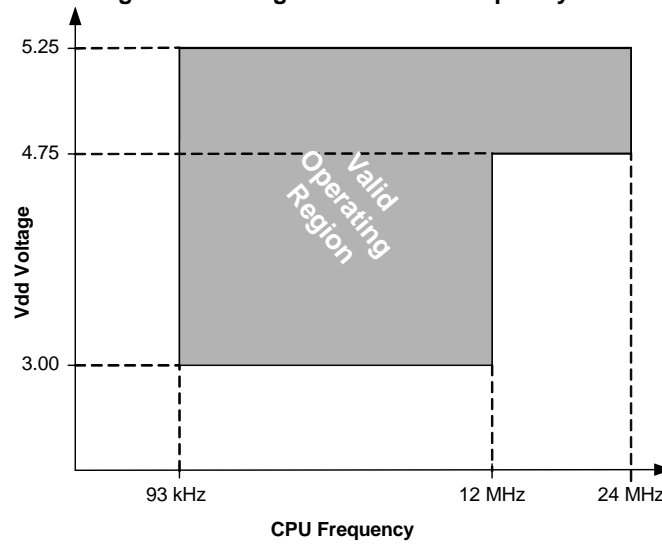

**Absolute Maximum Ratings**

Symbol	Description	Min	Typ	Max	Units	Notes
T <sub>STG</sub>	Storage temperature	-55	25	+100	°C	Higher storage temperatures will reduce data retention time. Recommended storage temperature is +25 °C ± 25 °C. Extended duration storage temperatures above 65 °C will degrade reliability.
T <sub>A</sub>	Ambient temperature with power applied	-40	-	+85	°C	
V <sub>DD</sub>	Supply voltage on V <sub>DD</sub> relative to V <sub>SS</sub>	-0.5	-	+6.0	V	
V <sub>I/O</sub>	DC input voltage	V <sub>SS</sub> - 0.5	-	V <sub>DD</sub> + 0.5	V	
V <sub>I/O2</sub>	DC voltage applied to tri-state	V <sub>SS</sub> - 0.5	-	V <sub>DD</sub> + 0.5	V	
I <sub>MI/O</sub>	Maximum current into any port pin	-25	-	+50	mA	
I <sub>MAI/O</sub>	Maximum current into any port pin configured as analog driver	-50	-	+50	mA	
ESD	Electrostatic discharge voltage	2000	-	-	V	Human Body Model ESD.
LU	Latch-up current	-	-	200	mA	

**Operating Temperature**

Symbol	Description	Min	Typ	Max	Units	Notes
T <sub>A</sub>	Ambient temperature	-40	-	+85	°C	
T <sub>AUSB</sub>	Ambient temperature using USB	-10	-	+85	°C	
T <sub>J</sub>	Junction temperature	-40	-	+100	°C	The temperature rise from ambient to junction is package specific. See <a href="#">"Thermal Impedance"</a> on page 38. The user must limit the power consumption to comply with this requirement.

**DC Electrical Characteristics**
*DC Chip-Level Specifications*

The following table lists guaranteed maximum and minimum specifications for the voltage and temperature ranges: 4.75 V to 5.25 V and  $-40\text{ }^{\circ}\text{C} \leq T_A \leq 85\text{ }^{\circ}\text{C}$ , or 3.0 V to 3.6 V and  $-40\text{ }^{\circ}\text{C} \leq T_A \leq 85\text{ }^{\circ}\text{C}$ , respectively. Typical parameters are measured at 5 V and 3.3 V at 25 °C and are for design guidance only.

Symbol	Description	Min	Typ	Max	Units	Notes
V <sub>DDP</sub>	V <sub>DD</sub> for programming and erase	4.5	5	5.5	V	This specification applies to the functional requirements of external programmer tools
V <sub>DDL</sub>	Low V <sub>DD</sub> for verify	3	3.1	3.2	V	This specification applies to the functional requirements of external programmer tools
V <sub>DDH</sub>	High V <sub>DD</sub> for verify	5.1	5.2	5.3	V	This specification applies to the functional requirements of external programmer tools
V <sub>DDIWRITE</sub>	Supply voltage for flash write operation	3.0	–	5.25	V	This specification applies to this device when it is executing internal flash writes
V <sub>DD</sub>	Supply voltage	3.0	–	5.25	V	See DC POR and LVD specifications, <a href="#">Table 15 on page 27</a> .
I <sub>DD5</sub>	Supply current, IMO = 24 MHz (5V)	–	14	27	mA	Conditions are V <sub>DD</sub> = 5.0 V, T <sub>A</sub> = 25 °C, CPU = 3 MHz, SYSCLK doubler disabled, VC1 = 1.5 MHz, VC2 = 93.75 kHz, VC3 = 93.75 kHz, analog power = off.
I <sub>DD3</sub>	Supply current, IMO = 24 MHz (3.3V)	–	8	14	mA	Conditions are V <sub>DD</sub> = 3.3 V, T <sub>A</sub> = 25 °C, CPU = 3 MHz, SYSCLK doubler disabled, VC1 = 1.5 MHz, VC2 = 93.75 kHz, VC3 = 0.367 kHz, analog power = off.
I <sub>SB</sub>	Sleep (mode) current with POR, LVD, Sleep Timer, and WDT <sup>[3]</sup>	–	3	6.5	μA	Conditions are with internal slow speed oscillator, V <sub>DD</sub> = 3.3 V, $-40\text{ }^{\circ}\text{C} \leq T_A \leq 55\text{ }^{\circ}\text{C}$ , analog power = off.
I <sub>SBH</sub>	Sleep (mode) current with POR, LVD, Sleep Timer, and WDT at high temperature. <sup>[3]</sup>	–	4	25	μA	Conditions are with internal slow speed oscillator, V <sub>DD</sub> = 3.3 V, $55\text{ }^{\circ}\text{C} < T_A \leq 85\text{ }^{\circ}\text{C}$ , analog power = off.

*DC GPIO Specifications*

The following table lists guaranteed maximum and minimum specifications for the voltage and temperature ranges: 4.75 V to 5.25 V and  $-40\text{ }^{\circ}\text{C} \leq T_A \leq 85\text{ }^{\circ}\text{C}$ , or 3.0 V to 3.6 V and  $-40\text{ }^{\circ}\text{C} \leq T_A \leq 85\text{ }^{\circ}\text{C}$ , respectively. Typical parameters are measured at 5 V and 3.3 V at 25 °C and are for design guidance only.

**Table 5. DC GPIO Specifications**

Symbol	Description	Min	Typ	Max	Units	Notes
R <sub>PU</sub>	Pull-up resistor	4	5.6	8	kΩ	
R <sub>PD</sub>	Pull-down resistor	4	5.6	8	kΩ	
V <sub>OH</sub>	High output level	V <sub>DD</sub> - 1.0	–	–	V	I/OH = 10 mA, V <sub>DD</sub> = 4.75 to 5.25 V (8 total loads, 4 on even port pins (for example, P0[2], P1[4]), 4 on odd port pins (for example, P0[3], P1[5])). 80 mA maximum combined I/OH budget.
V <sub>OL</sub>	Low output level	–	–	0.75	V	I/OL = 25 mA, V <sub>DD</sub> = 4.75 to 5.25 V (8 total loads, 4 on even port pins (for example, P0[2], P1[4]), 4 on odd port pins (for example, P0[3], P1[5])). 200 mA maximum combined I/OL budget.

**Note**

- Standby current includes all functions (POR, LVD, WDT, Sleep Time) needed for reliable system operation. This should be compared with devices that have similar functions enabled.

**Table 5. DC GPIO Specifications (continued)**

Symbol	Description	Min	Typ	Max	Units	Notes
I <sub>OH</sub>	High level source current	10	–	–	mA	V <sub>OH</sub> = V <sub>DD</sub> - 1.0 V. See the limitations of the total current in the Note for V <sub>OH</sub> .
I <sub>OL</sub>	Low level sink current	25	–	–	mA	V <sub>OL</sub> = 0.75 V. See the limitations of the total current in the Note for V <sub>OL</sub> .
V <sub>IL</sub>	Input low level	–	–	0.8	V	V <sub>DD</sub> = 3.0 to 5.25.
V <sub>IH</sub>	Input high level	2.1	–	–	V	V <sub>DD</sub> = 3.0 to 5.25.
V <sub>H</sub>	Input hysteresis	–	60	–	mV	
I <sub>IL</sub>	Input leakage (absolute value)	–	1	–	nA	Gross tested to 1 μA.
C <sub>IN</sub>	Capacitive load on pins as input	–	3.5	10	pF	Package and pin dependent. Temp = 25 °C.
C <sub>OUT</sub>	Capacitive load on pins as output	–	3.5	10	pF	Package and pin dependent. Temp = 25 °C.

**DC Full-Speed USB Specifications**

The following table lists guaranteed maximum and minimum specifications for the voltage and temperature ranges: 4.75 V to 5.25 V and –10 °C ≤ T<sub>A</sub> ≤ 85 °C, or 3.0 V to 3.6 V and –10 °C ≤ T<sub>A</sub> ≤ 85 °C, respectively. Typical parameters are measured at 5 V and 3.3 V at 25 °C and are for design guidance only.

**Table 6. DC Full-Speed (12 Mbps) USB Specifications**

Symbol	Description	Min	Typ	Max	Units	Notes
USB Interface						
V <sub>DI</sub>	Differential input sensitivity	0.2	–	–	V	(D+) - (D-)
V <sub>CM</sub>	Differential input common mode range	0.8	–	2.5	V	
V <sub>SE</sub>	Single ended receiver threshold	0.8	–	2.0	V	
C <sub>IN</sub>	Transceiver capacitance	–	–	20	pF	
I <sub>I/O</sub>	High-Z State data line leakage	–10	–	10	μA	0 V < V <sub>IN</sub> < 3.3 V.
R <sub>EXT</sub>	External USB series resistor	23	–	25	Ω	In series with each USB pin.
V <sub>UOH</sub>	Static output high, driven	2.8	–	3.6	V	15 kΩ ± 5% to Ground. Internal pull-up enabled.
V <sub>UOHI</sub>	Static output high, idle	2.7	–	3.6	V	15 kΩ ± 5% to Ground. Internal pull-up enabled.
V <sub>UOL</sub>	Static output low	–	–	0.3	V	15 kΩ ± 5% to Ground. Internal pull-up enabled.
Z <sub>O</sub>	USB driver output impedance	28	–	44	Ω	Including R <sub>EXT</sub> resistor.
V <sub>CRS</sub>	D+/D- crossover voltage	1.3	–	2.0	V	

**DC Operational Amplifier Specifications**

The following tables list guaranteed maximum and minimum specifications for the voltage and temperature ranges: 4.75 V to 5.25 V and  $-40\text{ }^{\circ}\text{C} \leq T_A \leq 85\text{ }^{\circ}\text{C}$ , or 3.0 V to 3.6 V and  $-40\text{ }^{\circ}\text{C} \leq T_A \leq 85\text{ }^{\circ}\text{C}$ , respectively. Typical parameters are measured at 5 V and 3.3 V at 25 °C and are for design guidance only.

The Operational Amplifier is a component of both the analog continuous time PSoC blocks and the analog switched capacitor PSoC blocks. The guaranteed specifications are measured in the analog continuous time PSoC block.

**Table 7. 5-V DC Operational Amplifier Specifications**

Symbol	Description	Min	Typ	Max	Units	Notes
$V_{OSO A}$	Input offset voltage (absolute value)					
	Power = low, opamp bias = high	–	1.6	10	mV	
	Power = medium, opamp bias = high	–	1.3	8	mV	
	Power = high, opamp bias = high	–	1.2	7.5	mV	
$TCV_{OSO A}$	Average input offset voltage drift	–	7.0	35.0	$\mu\text{V}/^{\circ}\text{C}$	
$I_{EBO A}$	Input leakage current (Port 0 analog pins)	–	20	–	pA	Gross tested to 1 $\mu\text{A}$ .
$C_{INO A}$	Input capacitance (Port 0 analog pins)	–	4.5	9.5	pF	Package and pin dependent. Temp = 25 °C.
$V_{CMO A}$	Common mode voltage range	0.0	–	$V_{DD}$	V	The common-mode input voltage range is measured through an analog output buffer. The specification includes the limitations imposed by the characteristics of the analog output buffer.
	Common mode voltage range (high power or high opamp bias)	0.5	–	$V_{DD} - 0.5$	V	
$G_{OLO A}$	Open loop gain					
	Power = low, opamp bias = high	60	–	–	dB	
	Power = medium, opamp bias = high	60	–	–	dB	
	Power = high, opamp bias = high	80	–	–	dB	
$V_{OHIGHO A}$	High output voltage swing (internal signals)					
	Power = low, opamp bias = high	$V_{DD} - 0.2$	–	–	V	
	Power = medium, opamp bias = high	$V_{DD} - 0.2$	–	–	V	
	Power = high, opamp bias = high	$V_{DD} - 0.5$	–	–	V	
$V_{OLOWO A}$	Low output voltage swing (internal signals)					
	Power = low, opamp bias = high	–	–	0.2	V	
	Power = medium, opamp bias = high	–	–	0.2	V	
	Power = high, opamp bias = high	–	–	0.5	V	
$I_{SO A}$	Supply current (including associated AGND buffer)					
	Power = low, opamp bias = low	–	400	800	$\mu\text{A}$	
	Power = low, opamp bias = high	–	500	900	$\mu\text{A}$	
	Power = medium, opamp bias = low	–	800	1000	$\mu\text{A}$	
	Power = medium, opamp bias = high	–	1200	1600	$\mu\text{A}$	
	Power = high, opamp bias = low	–	2400	3200	$\mu\text{A}$	
	Power = high, opamp bias = high	–	4600	6400	$\mu\text{A}$	
$PSRR_{O A}$	Supply voltage rejection ratio	65	80	–	dB	$V_{SS} \text{ } \& \text{ } V_{IN} \text{ } \& \text{ } (V_{DD} - 2.25)$ or $(V_{DD} - 1.25 \text{ V}) \text{ } \& \text{ } V_{IN} \text{ } \& \text{ } V_{DD}$ .

**Table 8. 3.3-V DC Operational Amplifier Specifications**

Symbol	Description	Min	Typ	Max	Units	Notes
V <sub>OSOA</sub>	Input offset voltage (absolute value)	–	1.65	10	mV	Power = high, opamp bias = high setting is not allowed for 3.3 V V <sub>DD</sub> operation
	Power = low, opamp bias = high	–	1.32	8	mV	
	Power = medium, opamp bias = high	–	–	–	mV	
	Power = high, opamp bias = high	–	–	–	mV	
TCV <sub>OSOA</sub>	Average input offset voltage drift	–	7.0	35.0	μV/°C	
I <sub>EBOA</sub>	Input leakage current (port 0 analog pins)	–	20	–	pA	Gross tested to 1 μA.
C <sub>INOA</sub>	Input capacitance (port 0 analog pins)	–	4.5	9.5	pF	Package and pin dependent. Temp = 25 °C.
V <sub>CMOA</sub>	Common mode voltage range	0.2	–	V <sub>DD</sub> – 0.2	V	The common-mode input voltage range is measured through an analog output buffer. The specification includes the limitations imposed by the characteristics of the analog output buffer.
G <sub>OLOA</sub>	Open loop gain	60	–	–	dB	Specification is applicable at Low opamp bias. For high opamp bias mode (except high power, High opamp bias), minimum is 60 dB.
	Power = low, opamp bias = low	60	–	–	dB	
	Power = medium, opamp bias = low	80	–	–	dB	
	Power = high, opamp bias = low	–	–	–	–	
V <sub>OHIGHOA</sub>	High output voltage swing (internal signals)	V <sub>DD</sub> – 0.2	–	–	V	Power = high, Opamp bias = high setting is not allowed for 3.3 V V <sub>DD</sub> operation
	Power = low, opamp bias = low	V <sub>DD</sub> – 0.2	–	–	V	
	Power = medium, opamp bias = low	V <sub>DD</sub> – 0.2	–	–	V	
	Power = high, opamp bias = low	V <sub>DD</sub> – 0.2	–	–	V	
V <sub>OLOWOA</sub>	Low output voltage swing (internal signals)	–	–	0.2	V	Power = high, opamp bias = high setting is not allowed for 3.3 V V <sub>DD</sub> operation
	Power = low, opamp bias = low	–	–	0.2	V	
	Power = medium, opamp bias = low	–	–	0.2	V	
	Power = high, opamp bias = low	–	–	0.2	V	
I <sub>SOA</sub>	Supply current (including associated AGND buffer)	–	–	–	–	Power = high, opamp bias = high setting is not allowed for 3.3 V V <sub>DD</sub> operation
	Power = low, opamp bias = low	–	400	800	μA	
	Power = low, opamp bias = high	–	500	900	μA	
	Power = medium, opamp bias = low	–	800	1000	μA	
	Power = medium, opamp bias = high	–	1200	1600	μA	
	Power = high, opamp bias = low	–	2400	3200	μA	
	Power = high, opamp bias = high	–	–	–	μA	
PSRR <sub>OA</sub>	Supply voltage rejection ratio	65	80	–	dB	V <sub>SS</sub> £ V <sub>IN</sub> £ (V <sub>DD</sub> – 2.25) or (V <sub>DD</sub> – 1.25 V) £ V <sub>IN</sub> £ V <sub>DD</sub>

**DC Low Power Comparator Specifications**

The following table lists guaranteed maximum and minimum specifications for the voltage and temperature ranges: 4.75 V to 5.25 V and  $-40\text{ }^{\circ}\text{C} \leq T_A \leq 85\text{ }^{\circ}\text{C}$ , 3.0 V to 3.6 V and  $-40\text{ }^{\circ}\text{C} \leq T_A \leq 85\text{ }^{\circ}\text{C}$ , or 2.4 V to 3.0 V and  $-40\text{ }^{\circ}\text{C} \leq T_A \leq 85\text{ }^{\circ}\text{C}$ , respectively. Typical parameters are measured at 5 V at 25 °C and are for design guidance only.

**Table 9. DC Low Power Comparator Specifications**

Symbol	Description	Min	Typ	Max	Units	Notes
$V_{REFLPC}$	Low power comparator (LPC) reference voltage range	0.2	–	$V_{DD} - 1$	V	
$I_{SLPC}$	LPC supply current	–	10	40	$\mu\text{A}$	
$V_{OSLPC}$	LPC voltage offset	–	2.5	30	mV	

**DC Analog Output Buffer Specifications**

The following tables list guaranteed maximum and minimum specifications for the voltage and temperature ranges: 4.75 V to 5.25 V and  $-40\text{ }^{\circ}\text{C} \leq T_A \leq 85\text{ }^{\circ}\text{C}$ , or 3.0 V to 3.6 V and  $-40\text{ }^{\circ}\text{C} \leq T_A \leq 85\text{ }^{\circ}\text{C}$ , respectively. Typical parameters are measured at 5 V and 3.3 V at 25 °C and are for design guidance only.

**Table 10. 5-V DC Analog Output Buffer Specifications**

Symbol	Description	Min	Typ	Max	Units	Notes
$C_L$	Load capacitance	–	–	200	pF	This specification applies to the external circuit that is being driven by the analog output buffer.
$V_{OSOB}$	Input offset voltage (absolute value)	–	3	12	mV	
$TCV_{OSOB}$	Average input offset voltage drift	–	+6	–	$\mu\text{V}/^{\circ}\text{C}$	
$V_{CMOB}$	Common mode input voltage range	0.5	–	$V_{DD} - 1.0$	V	
$R_{OUTOB}$	Output resistance Power = low Power = high	– –	0.6 0.6	– –	W W	
$V_{OHIGHOB}$	High output voltage swing (Load = 32 ohms to $V_{DD}/2$ ) Power = low Power = high	$0.5 \times V_{DD} + 1.1$ $0.5 \times V_{DD} + 1.1$	– –	– –	V V	
$V_{OLOWOB}$	Low output voltage swing (Load = 32 ohms to $V_{DD}/2$ ) Power = low Power = high	– –	– –	$0.5 \times V_{DD} - 1.3$ $0.5 \times V_{DD} - 1.3$	V V	
$I_{SOB}$	Supply current including opamp bias cell (No Load) Power = low Power = high	– –	1.1 2.6	5.1 8.8	mA mA	
$PSRR_{OB}$	Supply voltage rejection ratio	53	64	–	dB	$(0.5 \times V_{DD} - 1.3) \leq V_{OUT} \leq (V_{DD} - 2.3)$ .

**Table 11. 3.3-V DC Analog Output Buffer Specifications**

Symbol	Description	Min	Typ	Max	Units	Notes
$C_L$	Load capacitance	–	–	200	pF	This specification applies to the external circuit that is being driven by the analog output buffer.
$V_{OSOB}$	Input offset voltage (absolute value)	–	3	12	mV	
$TCV_{OSOB}$	Average input offset voltage drift	–	+6	–	$\mu\text{V}/^\circ\text{C}$	
$V_{CMOB}$	Common mode input voltage range	0.5	–	$V_{DD} - 1.0$	V	
$R_{OUTOB}$	Output resistance					
	Power = low Power = high	– –	1 1	– –	W W	
$V_{OHIGHOB}$	High output voltage swing (Load = 1 k $\Omega$ to $V_{DD}/2$ )					
	Power = low Power = high	$0.5 \times V_{DD} + 1.0$ $0.5 \times V_{DD} + 1.0$	– –	– –	V V	
$V_{OLOWOB}$	Low output voltage swing (Load = 1 k $\Omega$ to $V_{DD}/2$ )					
	Power = low Power = high	– –	– –	$0.5 \times V_{DD} - 1.0$ $0.5 \times V_{DD} - 1.0$	V V	
$I_{SOB}$	Supply current including opamp bias cell (No load)					
	Power = low Power = high	– –	0.8 2.0	2.0 4.3	mA mA	
$PSRR_{OB}$	Supply voltage rejection ratio	34	64	–	dB	$(0.5 \times V_{DD} - 1.0) \leq V_{OUT} \leq (0.5 \times V_{DD} + 0.9)$ .

**DC Analog Reference Specifications**

The following tables list guaranteed maximum and minimum specifications for the voltage and temperature ranges: 4.75 V to 5.25 V and  $-40\text{ }^{\circ}\text{C} \leq T_A \leq 85\text{ }^{\circ}\text{C}$ , or 3.0 V to 3.6 V and  $-40\text{ }^{\circ}\text{C} \leq T_A \leq 85\text{ }^{\circ}\text{C}$ , respectively. Typical parameters are measured at 5 V and 3.3 V at 25 °C and are for design guidance only.

The guaranteed specifications are measured through the analog continuous time PSoC blocks. The power levels for AGND refer to the power of the analog continuous time PSoC block. The power levels for RefHi and RefLo refer to the analog reference control register. The limits stated for AGND include the offset error of the AGND buffer local to the analog continuous time PSoC block. Reference control power is high.

**Table 12. 5-V DC Analog Reference Specifications**

Reference ARF_CR [5:3]	Reference Power Settings	Symbol	Reference	Description	Min	Typ	Max	Units
0b000	RefPower = high Opamp bias = high	V <sub>REFHI</sub>	Ref High	V <sub>DD</sub> /2 + Bandgap	V <sub>DD</sub> /2 + 1.229	V <sub>DD</sub> /2 + 1.290	V <sub>DD</sub> /2 + 1.346	V
		V <sub>AGND</sub>	AGND	V <sub>DD</sub> /2	V <sub>DD</sub> /2 - 0.038	V <sub>DD</sub> /2	V <sub>DD</sub> /2 + 0.040	V
		V <sub>REFLO</sub>	Ref Low	V <sub>DD</sub> /2 - Bandgap	V <sub>DD</sub> /2 - 1.356	V <sub>DD</sub> /2 - 1.295	V <sub>DD</sub> /2 - 1.218	V
	RefPower = high Opamp bias = low	V <sub>REFHI</sub>	Ref High	V <sub>DD</sub> /2 + Bandgap	V <sub>DD</sub> /2 + 1.220	V <sub>DD</sub> /2 + 1.292	V <sub>DD</sub> /2 + 1.348	V
		V <sub>AGND</sub>	AGND	V <sub>DD</sub> /2	V <sub>DD</sub> /2 - 0.036	V <sub>DD</sub> /2	V <sub>DD</sub> /2 + 0.036	V
		V <sub>REFLO</sub>	Ref Low	V <sub>DD</sub> /2 - Bandgap	V <sub>DD</sub> /2 - 1.357	V <sub>DD</sub> /2 - 1.297	V <sub>DD</sub> /2 - 1.225	V
	RefPower = medium Opamp bias = high	V <sub>REFHI</sub>	Ref High	V <sub>DD</sub> /2 + Bandgap	V <sub>DD</sub> /2 + 1.221	V <sub>DD</sub> /2 + 1.293	V <sub>DD</sub> /2 + 1.351	V
		V <sub>AGND</sub>	AGND	V <sub>DD</sub> /2	V <sub>DD</sub> /2 - 0.036	V <sub>DD</sub> /2	V <sub>DD</sub> /2 + 0.036	V
		V <sub>REFLO</sub>	Ref Low	V <sub>DD</sub> /2 - Bandgap	V <sub>DD</sub> /2 - 1.357	V <sub>DD</sub> /2 - 1.298	V <sub>DD</sub> /2 - 1.228	V
	RefPower = medium Opamp bias = low	V <sub>REFHI</sub>	Ref High	V <sub>DD</sub> /2 + Bandgap	V <sub>DD</sub> /2 + 1.219	V <sub>DD</sub> /2 + 1.293	V <sub>DD</sub> /2 + 1.353	V
		V <sub>AGND</sub>	AGND	V <sub>DD</sub> /2	V <sub>DD</sub> /2 - 0.037	V <sub>DD</sub> /2 - 0.001	V <sub>DD</sub> /2 + 0.036	V
		V <sub>REFLO</sub>	Ref Low	V <sub>DD</sub> /2 - Bandgap	V <sub>DD</sub> /2 - 1.359	V <sub>DD</sub> /2 - 1.299	V <sub>DD</sub> /2 - 1.229	V
0b001	RefPower = high Opamp bias = high	V <sub>REFHI</sub>	Ref High	P2[4]+P2[6] (P2[4] = V <sub>DD</sub> /2, P2[6] = 1.3 V)	P2[4] + P2[6] - 0.092	P2[4] + P2[6] - 0.011	P2[4] + P2[6] + 0.064	V
		V <sub>AGND</sub>	AGND	P2[4]	P2[4]	P2[4]	P2[4]	-
		V <sub>REFLO</sub>	Ref Low	P2[4]-P2[6] (P2[4] = V <sub>DD</sub> /2, P2[6] = 1.3 V)	P2[4] - P2[6] - 0.031	P2[4] - P2[6] + 0.007	P2[4] - P2[6] + 0.056	V
	RefPower = high Opamp bias = low	V <sub>REFHI</sub>	Ref High	P2[4]+P2[6] (P2[4] = V <sub>DD</sub> /2, P2[6] = 1.3 V)	P2[4] + P2[6] - 0.078	P2[4] + P2[6] - 0.008	P2[4] + P2[6] + 0.063	V
		V <sub>AGND</sub>	AGND	P2[4]	P2[4]	P2[4]	P2[4]	-
		V <sub>REFLO</sub>	Ref Low	P2[4]-P2[6] (P2[4] = V <sub>DD</sub> /2, P2[6] = 1.3 V)	P2[4] - P2[6] - 0.031	P2[4] - P2[6] + 0.004	P2[4] - P2[6] + 0.043	V
	RefPower = medium Opamp bias = high	V <sub>REFHI</sub>	Ref High	P2[4]+P2[6] (P2[4] = V <sub>DD</sub> /2, P2[6] = 1.3 V)	P2[4] + P2[6] - 0.073	P2[4] + P2[6] - 0.006	P2[4] + P2[6] + 0.062	V
		V <sub>AGND</sub>	AGND	P2[4]	P2[4]	P2[4]	P2[4]	-
		V <sub>REFLO</sub>	Ref Low	P2[4]-P2[6] (P2[4] = V <sub>DD</sub> /2, P2[6] = 1.3 V)	P2[4] - P2[6] - 0.032	P2[4] - P2[6] + 0.003	P2[4] - P2[6] + 0.038	V
	RefPower = medium Opamp bias = low	V <sub>REFHI</sub>	Ref High	P2[4]+P2[6] (P2[4] = V <sub>DD</sub> /2, P2[6] = 1.3 V)	P2[4] + P2[6] - 0.073	P2[4] + P2[6] - 0.006	P2[4] + P2[6] + 0.062	V
		V <sub>AGND</sub>	AGND	P2[4]	P2[4]	P2[4]	P2[4]	-
		V <sub>REFLO</sub>	Ref Low	P2[4]-P2[6] (P2[4] = V <sub>DD</sub> /2, P2[6] = 1.3 V)	P2[4] - P2[6] - 0.034	P2[4] - P2[6] + 0.002	P2[4] - P2[6] + 0.037	V

Table 12. 5-V DC Analog Reference Specifications (continued)

Reference ARF_CR [5:3]	Reference Power Settings	Symbol	Reference	Description	Min	Typ	Max	Units
0b010	RefPower = high Opamp bias = high	V <sub>REFHI</sub>	Ref High	V <sub>DD</sub>	V <sub>DD</sub> - 0.037	V <sub>DD</sub> - 0.007	V <sub>DD</sub>	V
		V <sub>AGND</sub>	AGND	V <sub>DD</sub> /2	V <sub>DD</sub> /2 - 0.036	V <sub>DD</sub> /2 - 0.001	V <sub>DD</sub> /2 + 0.036	V
		V <sub>REFLO</sub>	Ref Low	V <sub>SS</sub>	V <sub>SS</sub>	V <sub>SS</sub> + 0.005	V <sub>SS</sub> + 0.029	V
	RefPower = high Opamp bias = low	V <sub>REFHI</sub>	Ref High	V <sub>DD</sub>	V <sub>DD</sub> - 0.034	V <sub>DD</sub> - 0.006	V <sub>DD</sub>	V
		V <sub>AGND</sub>	AGND	V <sub>DD</sub> /2	V <sub>DD</sub> /2 - 0.036	V <sub>DD</sub> /2 - 0.001	V <sub>DD</sub> /2 + 0.035	V
		V <sub>REFLO</sub>	Ref Low	V <sub>SS</sub>	V <sub>SS</sub>	V <sub>SS</sub> + 0.004	V <sub>SS</sub> + 0.024	V
	RefPower = medium Opamp bias = high	V <sub>REFHI</sub>	Ref High	V <sub>DD</sub>	V <sub>DD</sub> - 0.032	V <sub>DD</sub> - 0.005	V <sub>DD</sub>	V
		V <sub>AGND</sub>	AGND	V <sub>DD</sub> /2	V <sub>DD</sub> /2 - 0.036	V <sub>DD</sub> /2 - 0.001	V <sub>DD</sub> /2 + 0.035	V
		V <sub>REFLO</sub>	Ref Low	V <sub>SS</sub>	V <sub>SS</sub>	V <sub>SS</sub> + 0.003	V <sub>SS</sub> + 0.022	V
	RefPower = medium Opamp bias = low	V <sub>REFHI</sub>	Ref High	V <sub>DD</sub>	V <sub>DD</sub> - 0.031	V <sub>DD</sub> - 0.005	V <sub>DD</sub>	V
		V <sub>AGND</sub>	AGND	V <sub>DD</sub> /2	V <sub>DD</sub> /2 - 0.037	V <sub>DD</sub> /2 - 0.001	V <sub>DD</sub> /2 + 0.035	V
		V <sub>REFLO</sub>	Ref Low	V <sub>SS</sub>	V <sub>SS</sub>	V <sub>SS</sub> + 0.003	V <sub>SS</sub> + 0.020	V
0b011	RefPower = high Opamp bias = high	V <sub>REFHI</sub>	Ref High	3 × Bandgap	3.760	3.884	4.006	V
		V <sub>AGND</sub>	AGND	2 × Bandgap	2.522	2.593	2.669	V
		V <sub>REFLO</sub>	Ref Low	Bandgap	1.252	1.299	1.342	V
	RefPower = high Opamp bias = low	V <sub>REFHI</sub>	Ref High	3 × Bandgap	3.766	3.887	4.010	V
		V <sub>AGND</sub>	AGND	2 × Bandgap	2.523	2.594	2.670	V
		V <sub>REFLO</sub>	Ref Low	Bandgap	1.252	1.297	1.342	V
	RefPower = medium Opamp bias = high	V <sub>REFHI</sub>	Ref High	3 × Bandgap	3.769	3.888	4.013	V
		V <sub>AGND</sub>	AGND	2 × Bandgap	2.523	2.594	2.671	V
		V <sub>REFLO</sub>	Ref Low	Bandgap	1.251	1.296	1.343	V
	RefPower = medium Opamp bias = low	V <sub>REFHI</sub>	Ref High	3 × Bandgap	3.769	3.889	4.015	V
		V <sub>AGND</sub>	AGND	2 × Bandgap	2.523	2.595	2.671	V
		V <sub>REFLO</sub>	Ref Low	Bandgap	1.251	1.296	1.344	V
0b100	RefPower = high Opamp bias = high	V <sub>REFHI</sub>	Ref High	2 × Bandgap + P2[6] (P2[6] = 1.3 V)	2.483 - P2[6]	2.582 - P2[6]	2.674 - P2[6]	V
		V <sub>AGND</sub>	AGND	2 × Bandgap	2.522	2.593	2.669	V
		V <sub>REFLO</sub>	Ref Low	2 × Bandgap - P2[6] (P2[6] = 1.3 V)	2.524 - P2[6]	2.600 - P2[6]	2.676 - P2[6]	V
	RefPower = high Opamp bias = low	V <sub>REFHI</sub>	Ref High	2 × Bandgap + P2[6] (P2[6] = 1.3 V)	2.490 - P2[6]	2.586 - P2[6]	2.679 - P2[6]	V
		V <sub>AGND</sub>	AGND	2 × Bandgap	2.523	2.594	2.669	V
		V <sub>REFLO</sub>	Ref Low	2 × Bandgap - P2[6] (P2[6] = 1.3 V)	2.523 - P2[6]	2.598 - P2[6]	2.675 - P2[6]	V
	RefPower = medium Opamp bias = high	V <sub>REFHI</sub>	Ref High	2 × Bandgap + P2[6] (P2[6] = 1.3 V)	2.493 - P2[6]	2.588 - P2[6]	2.682 - P2[6]	V
		V <sub>AGND</sub>	AGND	2 × Bandgap	2.523	2.594	2.670	V
		V <sub>REFLO</sub>	Ref Low	2 × Bandgap - P2[6] (P2[6] = 1.3 V)	2.523 - P2[6]	2.597 - P2[6]	2.675 - P2[6]	V
	RefPower = medium Opamp bias = low	V <sub>REFHI</sub>	Ref High	2 × Bandgap + P2[6] (P2[6] = 1.3 V)	2.494 - P2[6]	2.589 - P2[6]	2.685 - P2[6]	V
		V <sub>AGND</sub>	AGND	2 × Bandgap	2.523	2.595	2.671	V
		V <sub>REFLO</sub>	Ref Low	2 × Bandgap - P2[6] (P2[6] = 1.3 V)	2.522 - P2[6]	2.596 - P2[6]	2.676 - P2[6]	V

**Table 12. 5-V DC Analog Reference Specifications (continued)**

Reference ARF_CR [5:3]	Reference Power Settings	Symbol	Reference	Description	Min	Typ	Max	Units
0b101	RefPower = high Opamp bias = high	V <sub>REFHI</sub>	Ref High	P2[4] + Bandgap (P2[4] = V <sub>DD</sub> /2)	P2[4] + 1.218	P2[4] + 1.291	P2[4] + 1.354	V
		V <sub>AGND</sub>	AGND	P2[4]	P2[4]	P2[4]	P2[4]	–
		V <sub>REFLO</sub>	Ref Low	P2[4] – Bandgap (P2[4] = V <sub>DD</sub> /2)	P2[4] – 1.335	P2[4] – 1.294	P2[4] – 1.237	V
	RefPower = high Opamp bias = low	V <sub>REFHI</sub>	Ref High	P2[4] + Bandgap (P2[4] = V <sub>DD</sub> /2)	P2[4] + 1.221	P2[4] + 1.293	P2[4] + 1.358	V
		V <sub>AGND</sub>	AGND	P2[4]	P2[4]	P2[4]	P2[4]	–
		V <sub>REFLO</sub>	Ref Low	P2[4] – Bandgap (P2[4] = V <sub>DD</sub> /2)	P2[4] – 1.337	P2[4] – 1.297	P2[4] – 1.243	V
	RefPower = medium Opamp bias = high	V <sub>REFHI</sub>	Ref High	P2[4] + Bandgap (P2[4] = V <sub>DD</sub> /2)	P2[4] + 1.222	P2[4] + 1.294	P2[4] + 1.360	V
		V <sub>AGND</sub>	AGND	P2[4]	P2[4]	P2[4]	P2[4]	–
		V <sub>REFLO</sub>	Ref Low	P2[4] – Bandgap (P2[4] = V <sub>DD</sub> /2)	P2[4] – 1.338	P2[4] – 1.298	P2[4] – 1.245	V
	RefPower = medium Opamp bias = low	V <sub>REFHI</sub>	Ref High	P2[4] + Bandgap (P2[4] = V <sub>DD</sub> /2)	P2[4] + 1.221	P2[4] + 1.294	P2[4] + 1.362	V
		V <sub>AGND</sub>	AGND	P2[4]	P2[4]	P2[4]	P2[4]	–
		V <sub>REFLO</sub>	Ref Low	P2[4] – Bandgap (P2[4] = V <sub>DD</sub> /2)	P2[4] – 1.340	P2[4] – 1.298	P2[4] – 1.245	V
0b110	RefPower = high Opamp bias = high	V <sub>REFHI</sub>	Ref High	2 × Bandgap	2.513	2.593	2.672	V
		V <sub>AGND</sub>	AGND	Bandgap	1.264	1.302	1.340	V
		V <sub>REFLO</sub>	Ref Low	V <sub>SS</sub>	V <sub>SS</sub>	V <sub>SS</sub> + 0.008	V <sub>SS</sub> + 0.038	V
	RefPower = high Opamp bias = low	V <sub>REFHI</sub>	Ref High	2 × Bandgap	2.514	2.593	2.674	V
		V <sub>AGND</sub>	AGND	Bandgap	1.264	1.301	1.340	V
		V <sub>REFLO</sub>	Ref Low	V <sub>SS</sub>	V <sub>SS</sub>	V <sub>SS</sub> + 0.005	V <sub>SS</sub> + 0.028	V
	RefPower = medium Opamp bias = high	V <sub>REFHI</sub>	Ref High	2 × Bandgap	2.514	2.593	2.676	V
		V <sub>AGND</sub>	AGND	Bandgap	1.264	1.301	1.340	V
		V <sub>REFLO</sub>	Ref Low	V <sub>SS</sub>	V <sub>SS</sub>	V <sub>SS</sub> + 0.004	V <sub>SS</sub> + 0.024	V
	RefPower = medium Opamp bias = low	V <sub>REFHI</sub>	Ref High	2 × Bandgap	2.514	2.593	2.677	V
		V <sub>AGND</sub>	AGND	Bandgap	1.264	1.300	1.340	V
		V <sub>REFLO</sub>	Ref Low	V <sub>SS</sub>	V <sub>SS</sub>	V <sub>SS</sub> + 0.003	V <sub>SS</sub> + 0.021	V
0b111	RefPower = high Opamp bias = high	V <sub>REFHI</sub>	Ref High	3.2 × Bandgap	4.028	4.144	4.242	V
		V <sub>AGND</sub>	AGND	1.6 × Bandgap	2.028	2.076	2.125	V
		V <sub>REFLO</sub>	Ref Low	V <sub>SS</sub>	V <sub>SS</sub>	V <sub>SS</sub> + 0.008	V <sub>SS</sub> + 0.034	V
	RefPower = high Opamp bias = low	V <sub>REFHI</sub>	Ref High	3.2 × Bandgap	4.032	4.142	4.245	V
		V <sub>AGND</sub>	AGND	1.6 × Bandgap	2.029	2.076	2.126	V
		V <sub>REFLO</sub>	Ref Low	V <sub>SS</sub>	V <sub>SS</sub>	V <sub>SS</sub> + 0.005	V <sub>SS</sub> + 0.025	V
	RefPower = medium Opamp bias = high	V <sub>REFHI</sub>	Ref High	3.2 × Bandgap	4.034	4.143	4.247	V
		V <sub>AGND</sub>	AGND	1.6 × Bandgap	2.029	2.076	2.126	V
		V <sub>REFLO</sub>	Ref Low	V <sub>SS</sub>	V <sub>SS</sub>	V <sub>SS</sub> + 0.004	V <sub>SS</sub> + 0.021	V
	RefPower = medium Opamp bias = low	V <sub>REFHI</sub>	Ref High	3.2 × Bandgap	4.036	4.144	4.249	V
		V <sub>AGND</sub>	AGND	1.6 × Bandgap	2.029	2.076	2.126	V
		V <sub>REFLO</sub>	Ref Low	V <sub>SS</sub>	V <sub>SS</sub>	V <sub>SS</sub> + 0.003	V <sub>SS</sub> + 0.019	V

**Table 13. 3.3-V DC Analog Reference Specifications**

Reference ARF_CR [5:3]	Reference Power Settings	Symbol	Reference	Description	Min	Typ	Max	Units	
0b000	RefPower = high Opamp bias = high	V <sub>REFHI</sub>	Ref High	V <sub>DD</sub> /2 + Bandgap	V <sub>DD</sub> /2 + 1.200	V <sub>DD</sub> /2 + 1.290	V <sub>DD</sub> /2 + 1.365	V	
		V <sub>AGND</sub>	AGND	V <sub>DD</sub> /2	V <sub>DD</sub> /2 - 0.030	V <sub>DD</sub> /2	V <sub>DD</sub> /2 + 0.034	V	
		V <sub>REFLO</sub>	Ref Low	V <sub>DD</sub> /2 - Bandgap	V <sub>DD</sub> /2 - 1.346	V <sub>DD</sub> /2 - 1.292	V <sub>DD</sub> /2 - 1.208	V	
	RefPower = high Opamp bias = low	V <sub>REFHI</sub>	Ref High	V <sub>DD</sub> /2 + Bandgap	V <sub>DD</sub> /2 + 1.196	V <sub>DD</sub> /2 + 1.292	V <sub>DD</sub> /2 + 1.374	V	
		V <sub>AGND</sub>	AGND	V <sub>DD</sub> /2	V <sub>DD</sub> /2 - 0.029	V <sub>DD</sub> /2	V <sub>DD</sub> /2 + 0.031	V	
		V <sub>REFLO</sub>	Ref Low	V <sub>DD</sub> /2 - Bandgap	V <sub>DD</sub> /2 - 1.349	V <sub>DD</sub> /2 - 1.295	V <sub>DD</sub> /2 - 1.227	V	
	RefPower = medium Opamp bias = high	V <sub>REFHI</sub>	Ref High	V <sub>DD</sub> /2 + Bandgap	V <sub>DD</sub> /2 + 1.204	V <sub>DD</sub> /2 + 1.293	V <sub>DD</sub> /2 + 1.369	V	
		V <sub>AGND</sub>	AGND	V <sub>DD</sub> /2	V <sub>DD</sub> /2 - 0.030	V <sub>DD</sub> /2	V <sub>DD</sub> /2 + 0.030	V	
		V <sub>REFLO</sub>	Ref Low	V <sub>DD</sub> /2 - Bandgap	V <sub>DD</sub> /2 - 1.351	V <sub>DD</sub> /2 - 1.297	V <sub>DD</sub> /2 - 1.229	V	
	RefPower = medium Opamp bias = low	V <sub>REFHI</sub>	Ref High	V <sub>DD</sub> /2 + Bandgap	V <sub>DD</sub> /2 + 1.189	V <sub>DD</sub> /2 + 1.294	V <sub>DD</sub> /2 + 1.384	V	
		V <sub>AGND</sub>	AGND	V <sub>DD</sub> /2	V <sub>DD</sub> /2 - 0.032	V <sub>DD</sub> /2	V <sub>DD</sub> /2 + 0.029	V	
		V <sub>REFLO</sub>	Ref Low	V <sub>DD</sub> /2 - Bandgap	V <sub>DD</sub> /2 - 1.353	V <sub>DD</sub> /2 - 1.297	V <sub>DD</sub> /2 - 1.230	V	
0b001	RefPower = high Opamp bias = high	V <sub>REFHI</sub>	Ref High	P2[4]+P2[6] (P2[4] = V <sub>DD</sub> /2, P2[6] = 0.5 V)	P2[4] + P2[6] - 0.105	P2[4] + P2[6] - 0.008	P2[4] + P2[6] + 0.095	V	
		V <sub>AGND</sub>	AGND	P2[4]	P2[4]	P2[4]	P2[4]	-	
		V <sub>REFLO</sub>	Ref Low	P2[4]-P2[6] (P2[4] = V <sub>DD</sub> /2, P2[6] = 0.5 V)	P2[4] - P2[6] - 0.035	P2[4] - P2[6] + 0.006	P2[4] - P2[6] + 0.053	V	
	RefPower = high Opamp bias = low	V <sub>REFHI</sub>	Ref High	P2[4]+P2[6] (P2[4] = V <sub>DD</sub> /2, P2[6] = 0.5 V)	P2[4] + P2[6] - 0.094	P2[4] + P2[6] - 0.005	P2[4] + P2[6] + 0.073	V	
		V <sub>AGND</sub>	AGND	P2[4]	P2[4]	P2[4]	P2[4]	-	
		V <sub>REFLO</sub>	Ref Low	P2[4]-P2[6] (P2[4] = V <sub>DD</sub> /2, P2[6] = 0.5 V)	P2[4] - P2[6] - 0.033	P2[4] - P2[6] + 0.002	P2[4] - P2[6] + 0.042	V	
	RefPower = medium Opamp bias = high	V <sub>REFHI</sub>	Ref High	P2[4]+P2[6] (P2[4] = V <sub>DD</sub> /2, P2[6] = 0.5 V)	P2[4] + P2[6] - 0.094	P2[4] + P2[6] - 0.003	P2[4] + P2[6] + 0.075	V	
		V <sub>AGND</sub>	AGND	P2[4]	P2[4]	P2[4]	P2[4]	-	
		V <sub>REFLO</sub>	Ref Low	P2[4]-P2[6] (P2[4] = V <sub>DD</sub> /2, P2[6] = 0.5 V)	P2[4] - P2[6] - 0.035	P2[4] - P2[6]	P2[4] - P2[6] + 0.038	V	
	RefPower = medium Opamp bias = low	V <sub>REFHI</sub>	Ref High	P2[4]+P2[6] (P2[4] = V <sub>DD</sub> /2, P2[6] = 0.5 V)	P2[4] + P2[6] - 0.095	P2[4] + P2[6] - 0.003	P2[4] + P2[6] + 0.080	V	
		V <sub>AGND</sub>	AGND	P2[4]	P2[4]	P2[4]	P2[4]	-	
		V <sub>REFLO</sub>	Ref Low	P2[4]-P2[6] (P2[4] = V <sub>DD</sub> /2, P2[6] = 0.5 V)	P2[4] - P2[6] - 0.038	P2[4] - P2[6]	P2[4] - P2[6] + 0.038	V	
	0b010	RefPower = high Opamp bias = high	V <sub>REFHI</sub>	Ref High	V <sub>DD</sub>	V <sub>DD</sub> - 0.119	V <sub>DD</sub> - 0.005	V <sub>DD</sub>	V
			V <sub>AGND</sub>	AGND	V <sub>DD</sub> /2	V <sub>DD</sub> /2 - 0.028	V <sub>DD</sub> /2	V <sub>DD</sub> /2 + 0.029	V
			V <sub>REFLO</sub>	Ref Low	V <sub>SS</sub>	V <sub>SS</sub>	V <sub>SS</sub> + 0.004	V <sub>SS</sub> + 0.022	V
		RefPower = high Opamp bias = low	V <sub>REFHI</sub>	Ref High	V <sub>DD</sub>	V <sub>DD</sub> - 0.131	V <sub>DD</sub> - 0.004	V <sub>DD</sub>	V
			V <sub>AGND</sub>	AGND	V <sub>DD</sub> /2	V <sub>DD</sub> /2 - 0.028	V <sub>DD</sub> /2	V <sub>DD</sub> /2 + 0.028	V
			V <sub>REFLO</sub>	Ref Low	V <sub>SS</sub>	V <sub>SS</sub>	V <sub>SS</sub> + 0.003	V <sub>SS</sub> + 0.021	V
RefPower = medium Opamp bias = high		V <sub>REFHI</sub>	Ref High	V <sub>DD</sub>	V <sub>DD</sub> - 0.111	V <sub>DD</sub> - 0.003	V <sub>DD</sub>	V	
		V <sub>AGND</sub>	AGND	V <sub>DD</sub> /2	V <sub>DD</sub> /2 - 0.029	V <sub>DD</sub> /2	V <sub>DD</sub> /2 + 0.028	V	
		V <sub>REFLO</sub>	Ref Low	V <sub>SS</sub>	V <sub>SS</sub>	V <sub>SS</sub> + 0.002	V <sub>SS</sub> + 0.017	V	
RefPower = medium Opamp bias = low		V <sub>REFHI</sub>	Ref High	V <sub>DD</sub>	V <sub>DD</sub> - 0.128	V <sub>DD</sub> - 0.003	V <sub>DD</sub>	V	
		V <sub>AGND</sub>	AGND	V <sub>DD</sub> /2	V <sub>DD</sub> /2 - 0.029	V <sub>DD</sub> /2	V <sub>DD</sub> /2 + 0.029	V	
		V <sub>REFLO</sub>	Ref Low	V <sub>SS</sub>	V <sub>SS</sub>	V <sub>SS</sub> + 0.002	V <sub>SS</sub> + 0.019	V	

Table 13. 3.3-V DC Analog Reference Specifications (continued)

Reference ARF_CR [5:3]	Reference Power Settings	Symbol	Reference	Description	Min	Typ	Max	Units
0b011	All power settings. Not allowed for 3.3 V.	–	–	–	–	–	–	–
0b100	All power settings. Not allowed for 3.3 V.	–	–	–	–	–	–	–
0b101	RefPower = high Opamp bias = high	V <sub>REFHI</sub>	Ref High	P2[4] + Bandgap (P2[4] = V <sub>DD</sub> /2)	P2[4] + 1.214	P2[4] + 1.291	P2[4] + 1.359	V
		V <sub>AGND</sub>	AGND	P2[4]	P2[4]	P2[4]	P2[4]	–
		V <sub>REFLO</sub>	Ref Low	P2[4] – Bandgap (P2[4] = V <sub>DD</sub> /2)	P2[4] – 1.335	P2[4] – 1.292	P2[4] – 1.200	V
	RefPower = high Opamp bias = low	V <sub>REFHI</sub>	Ref High	P2[4] + Bandgap (P2[4] = V <sub>DD</sub> /2)	P2[4] + 1.219	P2[4] + 1.293	P2[4] + 1.357	V
		V <sub>AGND</sub>	AGND	P2[4]	P2[4]	P2[4]	P2[4]	–
		V <sub>REFLO</sub>	Ref Low	P2[4] – Bandgap (P2[4] = V <sub>DD</sub> /2)	P2[4] – 1.335	P2[4] – 1.295	P2[4] – 1.243	V
	RefPower = medium Opamp bias = high	V <sub>REFHI</sub>	Ref High	P2[4] + Bandgap (P2[4] = V <sub>DD</sub> /2)	P2[4] + 1.222	P2[4] + 1.294	P2[4] + 1.356	V
		V <sub>AGND</sub>	AGND	P2[4]	P2[4]	P2[4]	P2[4]	–
		V <sub>REFLO</sub>	Ref Low	P2[4] – Bandgap (P2[4] = V <sub>DD</sub> /2)	P2[4] – 1.337	P2[4] – 1.296	P2[4] – 1.244	V
	RefPower = medium Opamp bias = low	V <sub>REFHI</sub>	Ref High	P2[4] + Bandgap (P2[4] = V <sub>DD</sub> /2)	P2[4] + 1.224	P2[4] + 1.295	P2[4] + 1.355	V
		V <sub>AGND</sub>	AGND	P2[4]	P2[4]	P2[4]	P2[4]	–
		V <sub>REFLO</sub>	Ref Low	P2[4] – Bandgap (P2[4] = V <sub>DD</sub> /2)	P2[4] – 1.339	P2[4] – 1.297	P2[4] – 1.244	V
0b110	RefPower = high Opamp bias = high	V <sub>REFHI</sub>	Ref High	2 × Bandgap	2.510	2.595	2.655	V
		V <sub>AGND</sub>	AGND	Bandgap	1.276	1.301	1.332	V
		V <sub>REFLO</sub>	Ref Low	V <sub>SS</sub>	V <sub>SS</sub>	V <sub>SS</sub> + 0.006	V <sub>SS</sub> + 0.031	V
	RefPower = high Opamp bias = low	V <sub>REFHI</sub>	Ref High	2 × Bandgap	2.513	2.594	2.656	V
		V <sub>AGND</sub>	AGND	Bandgap	1.275	1.301	1.331	V
		V <sub>REFLO</sub>	Ref Low	V <sub>SS</sub>	V <sub>SS</sub>	V <sub>SS</sub> + 0.004	V <sub>SS</sub> + 0.021	V
	RefPower = medium Opamp bias = high	V <sub>REFHI</sub>	Ref High	2 × Bandgap	2.516	2.595	2.657	V
		V <sub>AGND</sub>	AGND	Bandgap	1.275	1.301	1.331	V
		V <sub>REFLO</sub>	Ref Low	V <sub>SS</sub>	V <sub>SS</sub>	V <sub>SS</sub> + 0.003	V <sub>SS</sub> + 0.017	V
	RefPower = medium Opamp bias = low	V <sub>REFHI</sub>	Ref High	2 × Bandgap	2.520	2.595	2.658	V
		V <sub>AGND</sub>	AGND	Bandgap	1.275	1.300	1.331	V
		V <sub>REFLO</sub>	Ref Low	V <sub>SS</sub>	V <sub>SS</sub>	V <sub>SS</sub> + 0.002	V <sub>SS</sub> + 0.015	V
0b111	All power settings. Not allowed for 3.3 V.	–	–	–	–	–	–	

**DC Analog PSoC Block Specifications**

The following table lists guaranteed maximum and minimum specifications for the voltage and temperature ranges: 4.75 V to 5.25 V and  $-40\text{ }^{\circ}\text{C} \leq T_A \leq 85\text{ }^{\circ}\text{C}$ , or 3.0 V to 3.6 V and  $-40\text{ }^{\circ}\text{C} \leq T_A \leq 85\text{ }^{\circ}\text{C}$ , respectively. Typical parameters are measured at 5 V and 3.3 V at 25 °C and are for design guidance only.

**Table 14. DC Analog PSoC Block Specifications**

Symbol	Description	Min	Typ	Max	Units	Notes
R <sub>CT</sub>	Resistor unit value (continuous time)	–	12.2	–	kΩ	
C <sub>SC</sub>	Capacitor unit value (switched capacitor)	–	80	–	fF	

**DC POR and LVD Specifications**

The following table lists guaranteed maximum and minimum specifications for the voltage and temperature ranges: 4.75 V to 5.25 V and  $-40\text{ }^{\circ}\text{C} \leq T_A \leq 85\text{ }^{\circ}\text{C}$ , or 3.0 V to 3.6 V and  $-40\text{ }^{\circ}\text{C} \leq T_A \leq 85\text{ }^{\circ}\text{C}$ , respectively. Typical parameters are measured at 5 V or 3.3 V at 25 °C and are for design guidance only.

**Note** The bits PORLEV and VM in the table below refer to bits in the VLT\_CR register.

**Table 15. DC POR and LVD Specifications**

Symbol	Description	Min	Typ	Max	Units	Notes
V <sub>PPOR0R</sub> V <sub>PPOR1R</sub> V <sub>PPOR2R</sub>	V <sub>DD</sub> Value for PPOR Trip (positive ramp) PORLEV[1:0] = 00b PORLEV[1:0] = 01b PORLEV[1:0] = 10b	–	2.91 4.39 4.55	–	V V V	
V <sub>PPOR0</sub> V <sub>PPOR1</sub> V <sub>PPOR2</sub>	V <sub>DD</sub> Value for PPOR Trip (negative ramp) PORLEV[1:0] = 00b PORLEV[1:0] = 01b PORLEV[1:0] = 10b	–	2.82 4.39 4.55	–	V V V	
V <sub>PH0</sub> V <sub>PH1</sub> V <sub>PH2</sub>	PPOR Hysteresis PORLEV[1:0] = 00b PORLEV[1:0] = 01b PORLEV[1:0] = 10b	–	92 0 0	–	mV mV mV	
V <sub>LVD0</sub> V <sub>LVD1</sub> V <sub>LVD2</sub> V <sub>LVD3</sub> V <sub>LVD4</sub> V <sub>LVD5</sub> V <sub>LVD6</sub> V <sub>LVD7</sub>	V <sub>DD</sub> Value for LVD Trip VM[2:0] = 000b VM[2:0] = 001b VM[2:0] = 010b VM[2:0] = 011b VM[2:0] = 100b VM[2:0] = 101b VM[2:0] = 110b VM[2:0] = 111b	2.86 2.96 3.07 3.92 4.39 4.55 4.63 4.72	2.92 3.02 3.13 4.00 4.48 4.64 4.73 4.81	2.98 <sup>[4]</sup> 3.08 3.20 4.08 4.57 4.74 <sup>[5]</sup> 4.82 4.91	V V V V V V V V	

**Notes**

- Always greater than 50 mV above PPOR (PORLEV = 00) for falling supply.
- Always greater than 50 mV above PPOR (PORLEV = 10) for falling supply.

**DC Programming Specifications**

The following table lists guaranteed maximum and minimum specifications for the voltage and temperature ranges: 4.75 V to 5.25 V and  $-40\text{ }^{\circ}\text{C} \leq T_A \leq 85\text{ }^{\circ}\text{C}$ , or 3.0 V to 3.6 V and  $-40\text{ }^{\circ}\text{C} \leq T_A \leq 85\text{ }^{\circ}\text{C}$ , respectively. Typical parameters are measured at 5 V and 3.3 V at 25 °C and are for design guidance only.

**Table 16. DC Programming Specifications**

Symbol	Description	Min	Typ	Max	Units	Notes
$I_{DDP}$	Supply current during programming or verify	–	15	30	mA	
$V_{ILP}$	Input low voltage during programming or verify	–	–	0.8	V	
$V_{IHP}$	Input high voltage during programming or verify	2.1	–	–	V	
$I_{ILP}$	Input current when applying $V_{ILP}$ to P1[0] or P1[1] during programming or verify	–	–	0.2	mA	Driving internal pull-down resistor.
$I_{IHP}$	Input current when applying $V_{IHP}$ to P1[0] or P1[1] during programming or Verify	–	–	1.5	mA	Driving internal pull-down resistor.
$V_{OLV}$	Output low voltage during programming or verify	–	–	$V_{SS} + 0.75$	V	
$V_{OHV}$	Output high voltage during programming or verify	$V_{DD} - 1.0$	–	$V_{DD}$	V	
Flash <sub>ENP</sub> <sub>B</sub>	Flash endurance (per block)	50,000 <sup>[6]</sup>	–	–	–	Erase/write cycles per block.
Flash <sub>ENT</sub>	Flash endurance (total) <sup>[7]</sup>	1,800,000	–	–	–	Erase/write cycles.
Flash <sub>DR</sub>	Flash data retention	10	–	–	Years	

**DC I<sup>2</sup>C Specifications**

The following table lists guaranteed maximum and minimum specifications for the voltage and temperature ranges: 4.75 V to 5.25 V and  $-40\text{ }^{\circ}\text{C} \leq T_A \leq 85\text{ }^{\circ}\text{C}$ , or 3.0 V to 3.6 V and  $-40\text{ }^{\circ}\text{C} \leq T_A \leq 85\text{ }^{\circ}\text{C}$ , respectively. Typical parameters are measured at 5 V and 3.3 V at 25 °C and are for design guidance only.

**Table 17. DC I<sup>2</sup>C Specifications<sup>[8]</sup>**

Symbol	Description	Min	Typ	Max	Units	Notes
$V_{ILI2C}$	Input low level	–	–	$0.3 \times V_{DD}$	V	3.0 V £ $V_{DD}$ £ 3.6 V
		–	–	$0.25 \times V_{DD}$	V	4.75 V £ $V_{DD}$ £ 5.25 V
$V_{IHI2C}$	Input high level	$0.7 \times V_{DD}$	–	–	V	3.0 V £ $V_{DD}$ £ 5.25 V

## AC Electrical Characteristics

### AC Chip-Level Specifications

The following table lists guaranteed maximum and minimum specifications for the voltage and temperature ranges: 4.75 V to 5.25 V and  $-40\text{ }^{\circ}\text{C} \leq T_A \leq 85\text{ }^{\circ}\text{C}$ , or 3.0 V to 3.6 V and  $-40\text{ }^{\circ}\text{C} \leq T_A \leq 85\text{ }^{\circ}\text{C}$ , respectively. Typical parameters are measured at 5 V and 3.3 V at 25 °C and are for design guidance only.

**Table 18. AC Chip-Level Specifications**

Symbol	Description	Min	Typ	Max	Units	Notes
F <sub>IMO245V</sub>	Internal main oscillator frequency for 24 MHz (5 V)	23.04	24	24.96 <sup>[6,7]</sup>	MHz	Trimmed for 5 V operation using factory trim values.
F <sub>IMO243V</sub>	Internal main oscillator frequency for 24 MHz (3.3 V)	22.08	24	25.92 <sup>[7,8]</sup>	MHz	Trimmed for 3.3 V operation using factory trim values.
F <sub>IMOUSB5V</sub>	Internal main oscillator frequency with USB (5 V) Frequency locking enabled and USB traffic present.	23.94	24	24.06 <sup>[7]</sup>	MHz	$-10\text{ }^{\circ}\text{C} \leq T_A \leq 85\text{ }^{\circ}\text{C}$ $4.35 \leq V_{DD} \leq 5.15$
F <sub>IMOUSB3V</sub>	Internal main oscillator frequency with USB (3.3 V) Frequency locking enabled and USB traffic present.	23.94	24	24.06 <sup>[7]</sup>	MHz	$-0\text{ }^{\circ}\text{C} \leq T_A \leq 70\text{ }^{\circ}\text{C}$ $3.15 \leq V_{DD} \leq 3.45$
F <sub>CPU1</sub>	CPU frequency (5 V nominal)	0.093	24	24.96 <sup>[6,7]</sup>	MHz	SLIMO mode = 0.
F <sub>CPU2</sub>	CPU frequency (3.3 V nominal)	0.093	12	12.96 <sup>[7,8]</sup>	MHz	SLIMO mode = 0.
F <sub>BLK5</sub>	Digital PSoC Block frequency (5 V nominal)	0	48	49.92 <sup>[6,7,9]</sup>	MHz	Refer to the AC digital block specifications.
F <sub>BLK3</sub>	Digital PSoC block frequency (3.3 V nominal)	0	24	25.92 <sup>[7,9]</sup>	MHz	
F <sub>32K1</sub>	Internal low speed oscillator frequency	15	32	64	kHz	
F <sub>32K_U</sub>	Internal low speed oscillator untrimmed frequency	5	–	100	kHz	After a reset and before the m8c starts to run, the ILO is not trimmed. See the System Resets section of the <a href="#">PSoC Technical Reference Manual</a> for details on timing this.
DC <sub>ILO</sub>	Internal low speed oscillator duty cycle	20	50	80	%	
Step24M	24 MHz trim step size	–	50	–	kHz	
F <sub>out48M</sub>	48 MHz output frequency	46.08	48.0	49.92 <sup>[6,8]</sup>	MHz	Trimmed. Utilizing factory trim values.
F <sub>MAX</sub>	Maximum frequency of signal on row input or row output.	–	–	12.96	MHz	
SR <sub>POWER_UP</sub>	Power supply slew rate	–	–	250	V/ms	V <sub>DD</sub> slew rate during power up.
T <sub>POWERUP</sub>	Time from end of POR to CPU executing code	–	16	100	ms	Power up from 0 V. See the System Resets section of the <a href="#">PSoC Technical Reference Manual</a> .
t <sub>jitter_IMO</sub> <sup>[10]</sup>	24 MHz IMO cycle-to-cycle jitter (RMS)	–	200	1200	ps	
	24 MHz IMO long term N cycle-to-cycle jitter (RMS)	–	900	6000	ps	N=32
	24 MHz IMO period jitter (RMS)	–	200	900	ps	

#### Notes

6. 4.75 V < V<sub>DD</sub> < 5.25 V.
7. Accuracy derived from Internal Main Oscillator with appropriate trim for V<sub>DD</sub> range.
8. 3.0 V < V<sub>DD</sub> < 3.6 V.
9. See the individual user module data sheets for information on maximum frequencies for user modules.
10. Refer to Cypress Jitter Specifications application note, [Understanding Datasheet Jitter Specifications for Cypress Timing Products – AN5054](#) for more information.

AC GPIO Specifications

The following table lists guaranteed maximum and minimum specifications for the voltage and temperature ranges: 4.75 V to 5.25 V and  $-40\text{ }^{\circ}\text{C} \leq T_A \leq 85\text{ }^{\circ}\text{C}$ , or 3.0 V to 3.6 V and  $-40\text{ }^{\circ}\text{C} \leq T_A \leq 85\text{ }^{\circ}\text{C}$ , respectively. Typical parameters are measured at 5 V and 3.3 V at 25 °C and are for design guidance only.

Table 19. AC GPIO Specifications

Symbol	Description	Min	Typ	Max	Units	Notes
$F_{GPIO}$	GPIO operating frequency	0	–	12	MHz	Normal strong mode
$T_{RiseF}$	Rise time, normal strong mode, Cload = 50 pF	3	–	18	ns	$V_{DD} = 4.5$ to $5.25$ V, 10% - 90%
$T_{FallF}$	Fall time, normal strong mode, Cload = 50 pF	2	–	18	ns	$V_{DD} = 4.5$ to $5.25$ V, 10% - 90%
$T_{RiseS}$	Rise Time, Slow Strong Mode, Cload = 50 pF	10	27	–	ns	$V_{DD} = 3$ to $5.25$ V, 10% - 90%
$T_{FallS}$	Fall time, slow strong mode, Cload = 50 pF	10	22	–	ns	$V_{DD} = 3$ to $5.25$ V, 10% - 90%

Figure 5. GPIO Timing Diagram

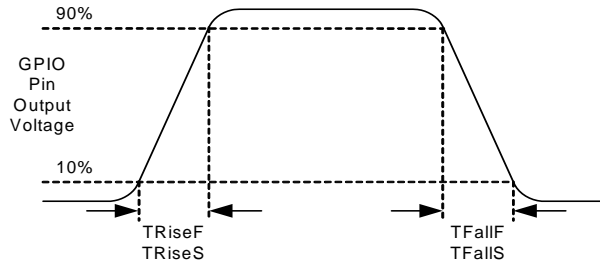

AC Full-Speed USB Specifications

The following table lists guaranteed maximum and minimum specifications for the voltage and temperature ranges: 4.75 V to 5.25 V and  $-10\text{ }^{\circ}\text{C} \leq T_A \leq 85\text{ }^{\circ}\text{C}$ , or 3.0 V to 3.6 V and  $-10\text{ }^{\circ}\text{C} \leq T_A \leq 85\text{ }^{\circ}\text{C}$ , respectively. Typical parameters are measured at 5 V and 3.3 V at 25 °C and are for design guidance only.

Table 20. AC Full-Speed (12 Mbps) USB Specifications

Symbol	Description	Min	Typ	Max	Units	Notes
$T_{RFS}$	Transition rise time	4	–	20	ns	For 50 pF load.
$T_{FSS}$	Transition fall time	4	–	20	ns	For 50 pF load.
$T_{RFMFS}$	Rise/fall time matching: ( $T_R/T_F$ )	90	–	111	%	For 50 pF load.
$T_{DRATEFS}$	Full-speed data rate	12 - 0.25%	12	12 + 0.25%	Mbps	

**AC Operational Amplifier Specifications**

The following tables list guaranteed maximum and minimum specifications for the voltage and temperature ranges: 4.75 V to 5.25 V and  $-40\text{ }^{\circ}\text{C} \leq T_A \leq 85\text{ }^{\circ}\text{C}$ , or 3.0 V to 3.6 V and  $-40\text{ }^{\circ}\text{C} \leq T_A \leq 85\text{ }^{\circ}\text{C}$ , respectively. Typical parameters are measured at 5 V and 3.3 V at 25 °C and are for design guidance only.

Settling times, slew rates, and gain bandwidth are based on the analog continuous time PSoC block.

Power = High and Opamp Bias = High is not supported at 3.3 V.

**Table 21. 5-V AC Operational Amplifier Specifications**

Symbol	Description	Min	Typ	Max	Units	Notes
T <sub>ROA</sub>	Rising settling time from 80% of DV to 0.1% of DV (10 pF load, unity gain)	–	–	3.9	ms	
	Power = Low, opamp bias = Low	–	–	0.72	ms	
	Power = Medium, opamp bias = High	–	–	0.62	ms	
	Power = High, opamp bias = High	–	–	–	–	
T <sub>SOA</sub>	Falling settling time from 20% of DV to 0.1% of DV (10 pF load, unity gain)	–	–	5.9	ms	
	Power = Low, opamp bias = Low	–	–	0.92	ms	
	Power = Medium, opamp bias = High	–	–	0.72	ms	
	Power = High, opamp bias = High	–	–	–	–	
SR <sub>ROA</sub>	Rising slew rate (20% to 80%)(10 pF load, unity gain)	0.15	–	–	V/ms	
	Power = Low, opamp bias = Low	1.7	–	–	V/ms	
	Power = Medium, opamp bias = High	6.5	–	–	V/ms	
	Power = High, opamp bias = High	–	–	–	–	
SR <sub>FOA</sub>	Falling slew rate (20% to 80%)(10 pF load, unity gain)	0.01	–	–	V/ms	
	Power = Low, opamp bias = Low	0.5	–	–	V/ms	
	Power = Medium, opamp bias = High	4.0	–	–	V/ms	
	Power = High, opamp bias = High	–	–	–	–	
BW <sub>OA</sub>	Gain bandwidth product	0.75	–	–	MHz	
	Power = Low, opamp bias = Low	3.1	–	–	MHz	
	Power = Medium, opamp bias = High	5.4	–	–	MHz	
	Power = High, opamp bias = High	–	–	–	–	
E <sub>NOA</sub>	Noise at 1 kHz (Power = Medium, opamp bias = High)	–	100	–	nV/rt-Hz	

**Table 22. 3.3-V AC Operational Amplifier Specifications**

Symbol	Description	Min	Typ	Max	Units	Notes
T <sub>ROA</sub>	Rising settling time from 80% of ΔV to 0.1% of ΔV (10 pF load, unity gain)	–	–	3.92	μs	
	Power = Low, opamp bias = Low	–	–	0.72	μs	
	Power = Medium, opamp bias = High	–	–	–	–	
T <sub>SOA</sub>	Falling settling time from 20% of ΔV to 0.1% of ΔV (10 pF load, unity gain)	–	–	5.41	μs	
	Power = Low, opamp bias = Low	–	–	0.72	μs	
	Power = Medium, Opamp Bias = High	–	–	–	–	
SR <sub>ROA</sub>	Rising slew rate (20% to 80%)(10 pF load, unity gain)	0.31	–	–	V/μs	
	Power = Low, opamp bias = Low	2.7	–	–	V/μs	
	Power = Medium, opamp bias = High	–	–	–	–	
SR <sub>FOA</sub>	Falling slew rate (20% to 80%)(10 pF load, unity gain)	0.24	–	–	V/μs	
	Power = Low, opamp bias = Low	1.8	–	–	V/μs	
	Power = Medium, opamp bias = High	–	–	–	–	
BW <sub>OA</sub>	Gain bandwidth product	0.67	–	–	MHz	
	Power = Low, opamp bias = Low	2.8	–	–	MHz	
	Power = Medium, opamp bias = High	–	–	–	–	
E <sub>NOA</sub>	Noise at 1 kHz (Power = Medium, opamp bias = High)	–	100	–	nV/rt-Hz	

When bypassed by a capacitor on P2[4], the noise of the analog ground signal distributed to each block is reduced by a factor of up to 5 (14 dB). This is at frequencies above the corner frequency defined by the on-chip 8.1k resistance and the external capacitor.

Figure 6. Typical AGND Noise with P2[4] Bypass

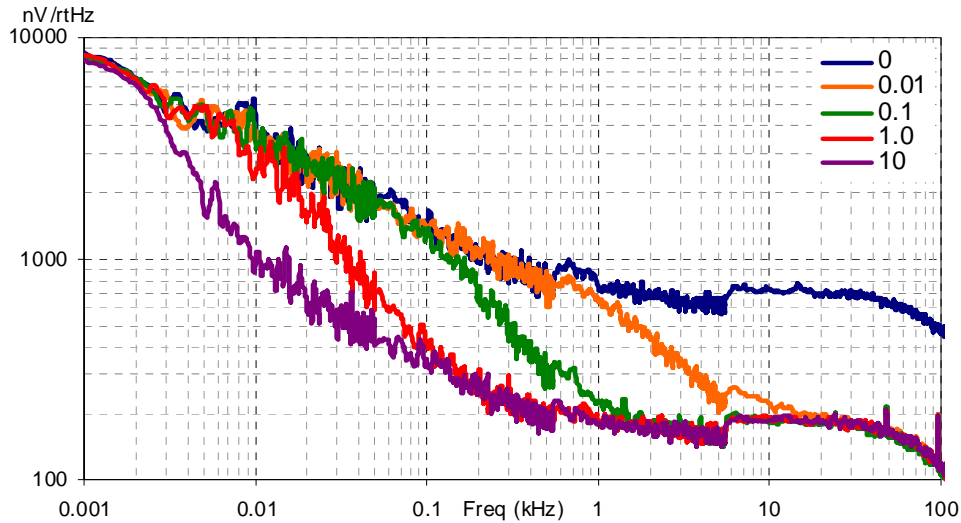

At low frequencies, the opamp noise is proportional to 1/f, power independent, and determined by device geometry. At high frequencies, increased power level reduces the noise spectrum level.

Figure 7. Typical Opamp Noise

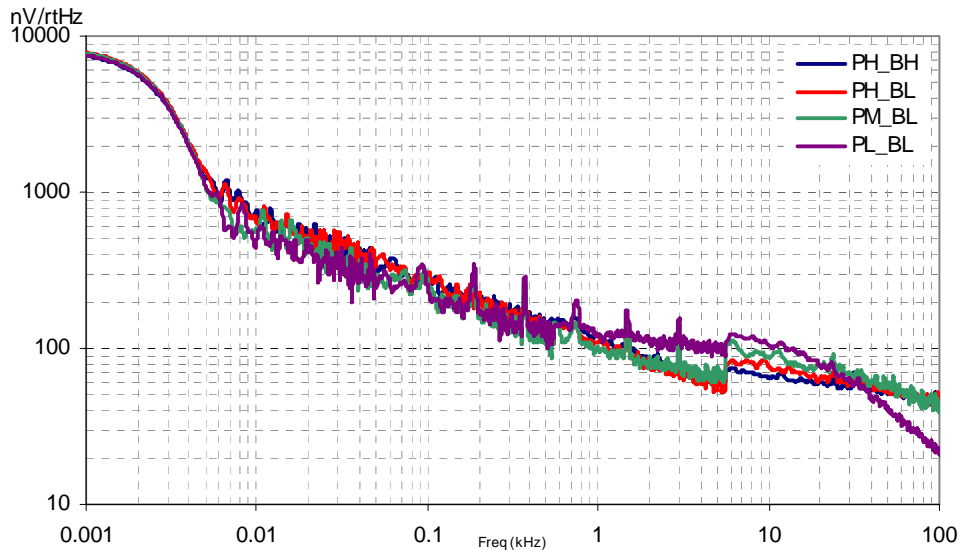

**AC Low Power Comparator Specifications**

The following table lists guaranteed maximum and minimum specifications for the voltage and temperature ranges: 4.75 V to 5.25 V and  $-40\text{ }^{\circ}\text{C} \leq T_A \leq 85\text{ }^{\circ}\text{C}$ , 3.0 V to 3.6 V and  $-40\text{ }^{\circ}\text{C} \leq T_A \leq 85\text{ }^{\circ}\text{C}$ , or 2.4 V to 3.0 V and  $-40\text{ }^{\circ}\text{C} \leq T_A \leq 85\text{ }^{\circ}\text{C}$ , respectively. Typical parameters are measured at 5 V at 25 °C and are for design guidance only.

**Table 23. AC Low Power Comparator Specifications**

Symbol	Description	Min	Typ	Max	Units	Notes
T <sub>RLPC</sub>	LPC response time	–	–	50	μs	≥ 50 mV overdrive comparator reference set within V <sub>REFLPC</sub> .

**AC Digital Block Specifications**

The following table lists guaranteed maximum and minimum specifications for the voltage and temperature ranges: 4.75 V to 5.25 V and  $-40\text{ }^{\circ}\text{C} \leq T_A \leq 85\text{ }^{\circ}\text{C}$ , or 3.0 V to 3.6 V and  $-40\text{ }^{\circ}\text{C} \leq T_A \leq 85\text{ }^{\circ}\text{C}$ , respectively. Typical parameters are measured at 5 V and 3.3 V at 25 °C and are for design guidance only.

**Table 24. AC Digital Block Specifications**

Function	Description	Min	Typ	Max	Unit	Notes
All functions	Block input clock frequency					
	V <sub>DD</sub> ≥ 4.75 V	–	–	49.92	MHz	
	V <sub>DD</sub> < 4.75 V	–	–	25.92	MHz	
Timer	Input clock frequency					
	No capture, V <sub>DD</sub> ≥ 4.75 V	–	–	49.92	MHz	
	No capture, V <sub>DD</sub> < 4.75 V	–	–	25.92	MHz	
	With capture	–	–	25.92	MHz	
	Capture pulse width	50 <sup>[11]</sup>	–	–	ns	
Counter	Input clock frequency					
	No enable input, V <sub>DD</sub> ≥ 4.75 V	–	–	49.92	MHz	
	No enable input, V <sub>DD</sub> < 4.75 V	–	–	25.92	MHz	
	With enable input	–	–	25.92	MHz	
	Enable input pulse width	50 <sup>[11]</sup>	–	–	ns	
	Kill pulse width					
	Asynchronous restart mode	20	–	–	ns	
	Synchronous restart mode	50 <sup>[11]</sup>	–	–	ns	
	Disable mode	50 <sup>[11]</sup>	–	–	ns	
	Input clock frequency					
	V <sub>DD</sub> ≥ 4.75 V	–	–	49.92	MHz	
	V <sub>DD</sub> < 4.75 V	–	–	25.92	MHz	
CRCPRS (PRS Mode)	Input clock frequency					
	V <sub>DD</sub> ≥ 4.75 V	–	–	49.92	MHz	
	V <sub>DD</sub> < 4.75 V	–	–	25.92	MHz	
CRCPRS (CRC Mode)	Input clock frequency	–	–	24.6	MHz	
SPIM	Input clock frequency	–	–	8.2	MHz	The SPI serial clock (SCLK) frequency is equal to the input clock frequency divided by 2.
SPIS	Input clock (SCLK) frequency	–	–	4.1	MHz	The input clock is the SPI SCLK in SPIS mode.
	Width of SS_negated between transmissions	50 <sup>[11]</sup>	–	–	ns	

**Note**

11. 50 ns minimum input pulse width is based on the input synchronizers running at 24 MHz (42 ns nominal period).

**Table 24. AC Digital Block Specifications** (continued)

Function	Description	Min	Typ	Max	Unit	Notes
Transmitter	Input clock frequency					The baud rate is equal to the input clock frequency divided by 8.
	$V_{DD} \geq 4.75$ V, 2 stop bits	–	–	49.92	MHz	
	$V_{DD} \geq 4.75$ V, 1 stop bit	–	–	24.6	MHz	
	$V_{DD} < 4.75$ V	–	–	24.6	MHz	
Receiver	Input clock frequency					The baud rate is equal to the input clock frequency divided by 8.
	$V_{DD} \geq 4.75$ V, 2 stop bits	–	–	49.92	MHz	
	$V_{DD} \geq 4.75$ V, 1 stop bit	–	–	24.6	MHz	
	$V_{DD} < 4.75$ V	–	–	24.6	MHz	

**AC External Clock Specifications**

The following tables list guaranteed maximum and minimum specifications for the voltage and temperature ranges: 4.75 V to 5.25 V and  $-40\text{ }^{\circ}\text{C} \leq T_A \leq 85\text{ }^{\circ}\text{C}$ , or 3.0 V to 3.6 V and  $-40\text{ }^{\circ}\text{C} \leq T_A \leq 85\text{ }^{\circ}\text{C}$ , respectively. Typical parameters are measured at 5 V and 3.3 V at 25 °C and are for design guidance only.

**Table 25. AC External Clock Specifications**

Symbol	Description	Min	Typ	Max	Units	Notes
$F_{OSCEXT}$	Frequency for USB applications	23.94	24	24.06	MHz	
–	Duty cycle	47	50	53	%	
–	Power up to IMO switch	150	–	–	$\mu\text{s}$	

**AC Analog Output Buffer Specifications**

The following tables list guaranteed maximum and minimum specifications for the voltage and temperature ranges: 4.75 V to 5.25 V and  $-40\text{ }^{\circ}\text{C} \leq T_A \leq 85\text{ }^{\circ}\text{C}$ , or 3.0 V to 3.6 V and  $-40\text{ }^{\circ}\text{C} \leq T_A \leq 85\text{ }^{\circ}\text{C}$ , respectively. Typical parameters are measured at 5 V and 3.3 V at 25 °C and are for design guidance only.

**Table 26. 5-V AC Analog Output Buffer Specifications**

Symbol	Description	Min	Typ	Max	Units	Notes
$T_{ROB}$	Rising settling time to 0.1%, 1 V Step, 100 pF load Power = Low Power = High	–	–	2.5	$\mu\text{s}$	
		–	–	2.5	$\mu\text{s}$	
$T_{SOB}$	Falling settling time to 0.1%, 1 V Step, 100 pF load Power = Low Power = High	–	–	2.2	$\mu\text{s}$	
		–	–	2.2	$\mu\text{s}$	
$SR_{ROB}$	Rising slew rate (20% to 80%), 1 V Step, 100 pF load Power = Low Power = High	0.65	–	–	$\text{V}/\mu\text{s}$	
		0.65	–	–	$\text{V}/\mu\text{s}$	
$SR_{FOB}$	Falling slew rate (80% to 20%), 1 V Step, 100 pF load Power = Low Power = High	0.65	–	–	$\text{V}/\mu\text{s}$	
		0.65	–	–	$\text{V}/\mu\text{s}$	
$BW_{OBSS}$	Small signal bandwidth, 20 mV <sub>pp</sub> , 3 dB BW, 100 pF load Power = Low Power = High	0.8	–	–	MHz	
		0.8	–	–	MHz	
$BW_{OBLs}$	Large signal bandwidth, 1 V <sub>pp</sub> , 3 dB BW, 100 pF load Power = Low Power = High	300	–	–	kHz	
		300	–	–	kHz	

**Table 27. 3.3-V AC Analog Output Buffer Specifications**

Symbol	Description	Min	Typ	Max	Units	Notes
$T_{ROB}$	Rising settling time to 0.1%, 1 V Step, 100 pF load Power = Low Power = High	– –	– –	3.8 3.8	$\mu\text{s}$ $\mu\text{s}$	
$T_{SOB}$	Falling settling time to 0.1%, 1 V Step, 100 pF load Power = Low Power = High	– –	– –	2.6 2.6	$\mu\text{s}$ $\mu\text{s}$	
$SR_{ROB}$	Rising slew rate (20% to 80%), 1 V Step, 100 pF load Power = Low Power = High	0.5 0.5	– –	– –	$\text{V}/\mu\text{s}$ $\text{V}/\mu\text{s}$	
$SR_{FOB}$	Falling slew rate (80% to 20%), 1 V Step, 100 pF load Power = Low Power = High	0.5 0.5	– –	– –	$\text{V}/\mu\text{s}$ $\text{V}/\mu\text{s}$	
$BW_{OBSS}$	Small signal bandwidth, 20 mV <sub>pp</sub> , 3 dB BW, 100 pF load Power = Low Power = High	0.7 0.7	– –	– –	MHz MHz	
$BW_{OBLs}$	Large signal bandwidth, 1 V <sub>pp</sub> , 3 dB BW, 100 pF load Power = Low Power = High	200 200	– –	– –	kHz kHz	

#### AC Programming Specifications

The following table lists guaranteed maximum and minimum specifications for the voltage and temperature ranges: 4.75 V to 5.25 V and  $-40\text{ }^{\circ}\text{C} \leq T_A \leq 85\text{ }^{\circ}\text{C}$ , or 3.0 V to 3.6 V and  $-40\text{ }^{\circ}\text{C} \leq T_A \leq 85\text{ }^{\circ}\text{C}$ , respectively. Typical parameters are measured at 5 V and 3.3 V at 25 °C and are for design guidance only.

**Table 28. AC Programming Specifications**

Symbol	Description	Min	Typ	Max	Units	Notes
$T_{RSCLK}$	Rise time of SCLK	1	–	20	ns	
$T_{FSCLK}$	Fall time of SCLK	1	–	20	ns	
$T_{SSCLK}$	Data setup time to falling edge of SCLK	40	–	–	ns	
$T_{HSCLK}$	Data hold time from falling edge of SCLK	40	–	–	ns	
$F_{SCLK}$	Frequency of SCLK	0	–	8	MHz	
$T_{ERASEB}$	Flash erase time (Block)	–	10	–	ms	
$T_{WRITE}$	Flash block write time	–	40	–	ms	
$T_{DSCLK}$	Data out delay from falling edge of SCLK	–	–	45	ns	$V_{DD} > 3.6$
$T_{DSCLK3}$	Data out delay from falling edge of SCLK	–	–	50	ns	$3.0 \leq V_{DD} \leq 3.6$
$T_{ERASEALL}$	Flash erase time (Bulk)	–	40	–	ms	Erase all blocks and protection fields at once.
$T_{PROGRAM\_HOT}$	Flash block erase + flash block write time	–	–	100 <sup>[12]</sup>	ms	$0\text{ }^{\circ}\text{C} \leq T_J \leq 100\text{ }^{\circ}\text{C}$
$T_{PROGRAM\_COLD}$	Flash block erase + flash block write time	–	–	200 <sup>[12]</sup>	ms	$-40\text{ }^{\circ}\text{C} \leq T_J \leq 0\text{ }^{\circ}\text{C}$

**Note**

12. For the full industrial range, you must employ a Temperature Sensor User Module (FlashTemp) and feed the result to the temperature argument before writing. Refer to the Flash APIs Application Note, AN2015 - PSoC® 1 - Reading and Writing PSoC Flash for more information.

AC I<sup>2</sup>C Specifications

The following table lists guaranteed maximum and minimum specifications for the voltage and temperature ranges: 4.75 V to 5.25 V and  $-40\text{ }^{\circ}\text{C} \leq T_A \leq 85\text{ }^{\circ}\text{C}$ , or 3.0 V to 3.6 V and  $-40\text{ }^{\circ}\text{C} \leq T_A \leq 85\text{ }^{\circ}\text{C}$ , respectively. Typical parameters are measured at 5 V and 3.3 V at 25 °C and are for design guidance only.

Table 29. AC Characteristics of the I<sup>2</sup>C SDA and SCL Pins for V<sub>DD</sub>

Symbol	Description	Standard-Mode		Fast-Mode		Units	Notes
		Min	Max	Min	Max		
F <sub>SCL I2C</sub>	SCL clock frequency	0	100	0	400	kHz	
T <sub>HDSTAI2C</sub>	Hold time (repeated) START condition. After this period, the first clock pulse is generated.	4.0	–	0.6	–	μs	
T <sub>LOWI2C</sub>	LOW period of the SCL clock	4.7	–	1.3	–	μs	
T <sub>HIGHI2C</sub>	HIGH period of the SCL clock	4.0	–	0.6	–	μs	
T <sub>SUSTAI2C</sub>	Setup time for a repeated START condition.	4.7	–	0.6	–	μs	
T <sub>HDDATI2C</sub>	Data hold time	0	–	0	–	μs	
T <sub>SUDATI2C</sub>	Data setup time	250	–	100 <sup>[13]</sup>	–	ns	
T <sub>SUSTOI2C</sub>	Setup time for STOP condition	4.0	–	0.6	–	μs	
T <sub>BUFI2C</sub>	Bus free time between a STOP and START condition	4.7	–	1.3	–	μs	
T <sub>SPI2C</sub>	Pulse width of spikes are suppressed by the input filter.	–	–	0	50	ns	

Figure 8. Definition for Timing for Fast-/Standard-Mode on the I<sup>2</sup>C Bus

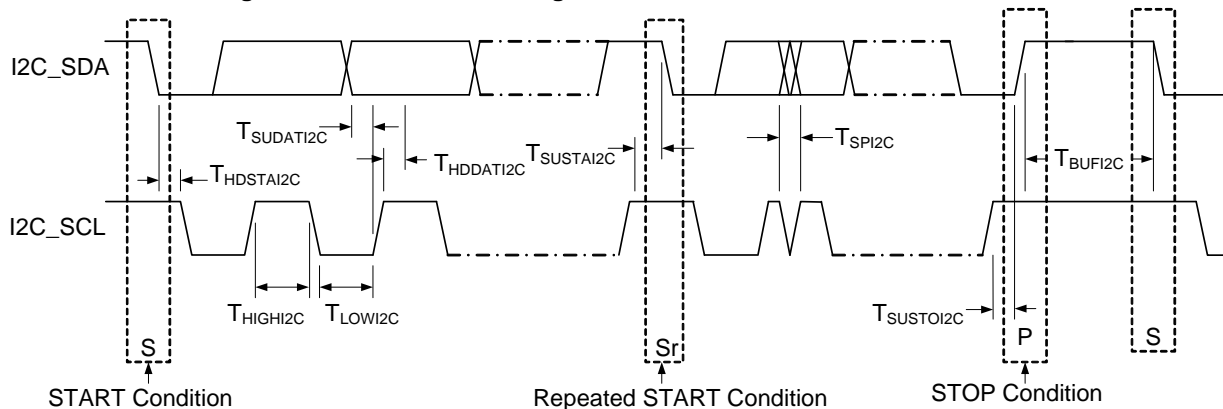

Note

13. A Fast-Mode I<sup>2</sup>C-bus device can be used in a Standard-Mode I<sup>2</sup>C-bus system, but the requirement  $t_{SU,DAT} \geq 250\text{ ns}$  must then be met. This will automatically be the case if the device does not stretch the LOW period of the SCL signal. If such device does stretch the LOW period of the SCL signal, it must output the next data bit to the SDA line  $t_{max} + t_{SU,DAT} = 1000 + 250 = 1250\text{ ns}$  (according to the Standard-Mode I<sup>2</sup>C-bus specification) before the SCL line is released.

### Packaging Information

This section illustrates the package specification for the CY8CLED04 EZ-Color device, along with the thermal impedance for the package and solder reflow peak temperatures.

**Important Note** Emulation tools may require a larger area on the target PCB than the chip's footprint. For a detailed description of the emulation tools' dimensions, refer to the document titled *PSoC Emulator Pod Dimensions* at <http://www.cypress.com/design/MR10161>.

**Figure 9. 68-Pin (8 × 8 × 0.90 mm) QFN (Sawn Type)**

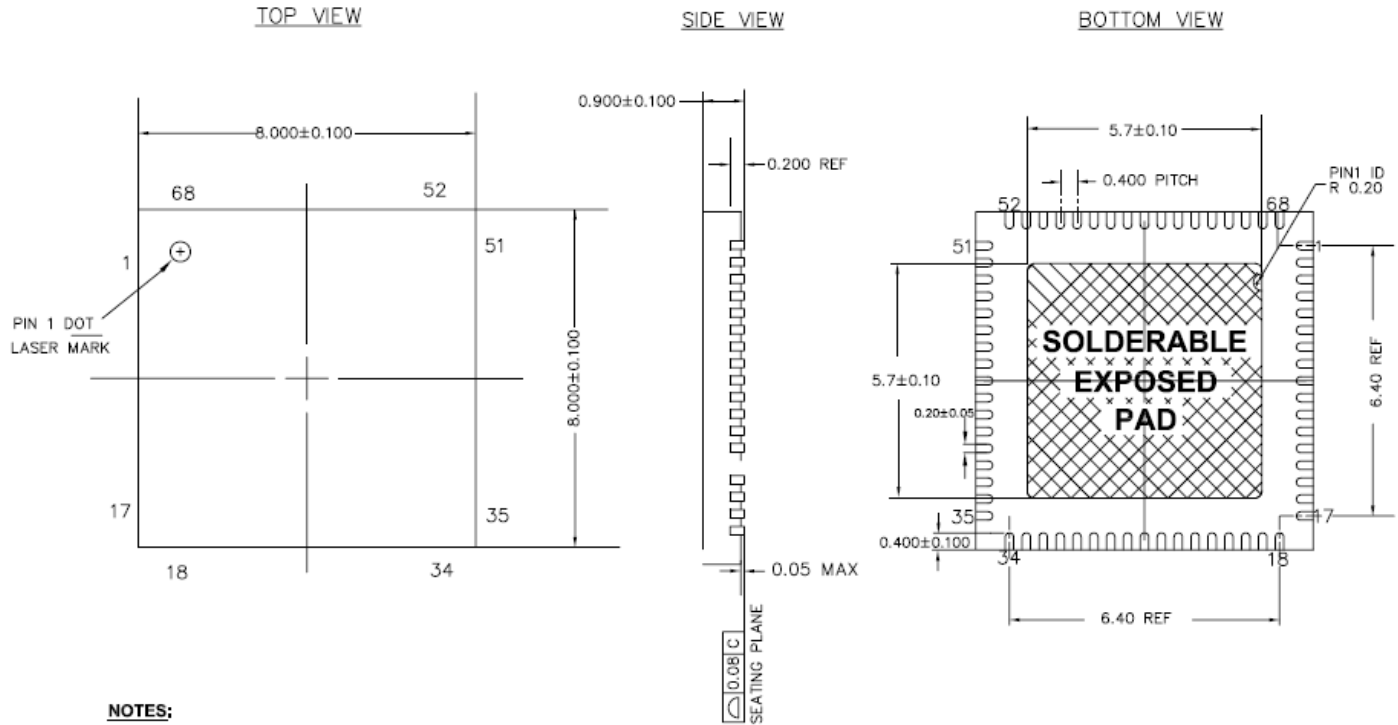

- NOTES:**
1.  HATCH AREA IS SOLDERABLE EXPOSED METAL.
  2. REFERENCE JEDEC#: MO-220
  3. PACKAGE WEIGHT: 0.17g
  4. ALL DIMENSIONS ARE IN MILLIMETERS

001-09618 °C

### Important Note

For information on the preferred dimensions for mounting QFN packages, see the following Application Note at [http://www.amkor.com/products/notes\\_papers/MLFAppNote.pdf](http://www.amkor.com/products/notes_papers/MLFAppNote.pdf).

Pinned vias for thermal conduction are not required for the low-power device.

**Thermal Impedance**

Package	Typical $\theta_{JA}$ <sup>[14, 15]</sup>
68-pin QFN	13.05 °C/W

**Solder Reflow Peak Temperature**

Following is the minimum solder reflow peak temperature to achieve good solderability.

Package	Maximum Peak Temperature	Time at Maximum Peak Temperature
68-pin QFN	260 °C	30 s

**Notes**

14.  $T_J = T_A + \text{POWER} \times \theta_{JA}$

15. To achieve the thermal impedance specified for the QFN package, the center thermal pad should be soldered to the PCB ground plane.

## Development Tools

### Software

This section presents the development tools available for all current PSoC device families including the CY8CLED04 EZ-Color.

#### *PSoC Designer™*

At the core of the PSoC development software suite is PSoC Designer, used to generate PSoC firmware applications. PSoC Designer is available free of charge at <http://www.cypress.com/psocdesigner> and includes a free C compiler.

#### *PSoC Programmer*

Flexible enough to be used on the bench in development, yet suitable for factory programming, PSoC Programmer works either as a standalone programming application or it can operate directly from PSoC Designer. PSoC Programmer software is compatible with both PSoC ICE-Cube In-Circuit Emulator and PSoC MiniProg. PSoC programmer is available free of charge at <http://www.cypress.com/psocprogrammer>.

### Evaluation Tools

All evaluation tools can be purchased from the Cypress Online Store.

#### *CY3210-MiniProg1*

The [CY3210-MiniProg1 kit](#) allows a user to program PSoC devices via the MiniProg1 programming unit. The MiniProg is a small, compact prototyping programmer that connects to the PC via a provided USB 2.0 cable. The kit includes:

- MiniProg Programming Unit
- MiniEval Socket Programming and Evaluation Board
- 28-Pin CY8C29466-24PXI PDIP PSoC Device Sample
- 28-Pin CY8C27443-24PXI PDIP PSoC Device Sample
- PSoC Designer Software CD
- Getting Started Guide
- USB 2.0 Cable

#### *CY3210-PSoCEval1*

The [CY3210-PSoCEval1 kit](#) features an evaluation board and the MiniProg1 programming unit. The evaluation board includes

an LCD module, potentiometer, LEDs, and plenty of bread-boarding space to meet all of your evaluation needs. The kit includes:

- Evaluation Board with LCD Module
- MiniProg Programming Unit
- 28-Pin CY8C29466-24PXI PDIP PSoC Device Sample (2)
- PSoC Designer Software CD
- Getting Started Guide
- USB 2.0 Cable

### Device Programmers

All device programmers can be purchased from the Cypress Online Store.

#### *CY3216 Modular Programmer*

The [CY3216 Modular Programmer kit](#) features a modular programmer and the MiniProg1 programming unit. The modular programmer includes three programming module cards and supports multiple Cypress products. The kit includes:

- Modular Programmer Base
- 3 Programming Module Cards
- MiniProg Programming Unit
- PSoC Designer Software CD
- Getting Started Guide
- USB 2.0 Cable

#### *CY3207ISSP In-System Serial Programmer (ISSP)*

The [CY3207ISSP](#) is a production programmer. It includes protection circuitry and an industrial case that is more robust than the MiniProg in a production-programming environment.

**Note** CY3207ISSP needs special software and is not compatible with PSoC Programmer. The kit includes:

- CY3207 Programmer Unit
- PSoC ISSP Software CD
- 110 ~ 240 V Power Supply, Euro-Plug Adapter
- USB 2.0 Cable
-

**Accessories (Emulation and Programming)**

**Table 30. Emulation and Programming Accessories**

Part #	Pin Package	Flex-Pod Kit <sup>[16]</sup>	Adapter <sup>[17]</sup>
CY8CLED04-68LTXI	68-pin QFN	CY3250-LED04	Adapters can be found at <a href="http://www.emulation.com">http://www.emulation.com</a> .

**Third Party Tools**

Several tools have been specially designed by the following third-party vendors to accompany PSoC devices during development and production. Specific details for each of these tools can be found at <http://www.cypress.com> under Design Support >> Development Kits/Boards.

**Build a PSoC Emulator into Your Board**

For details on how to emulate your circuit before going to volume production using an on-chip debug (OCD) non-production PSoC device, see Application Note *Debugging - Build a PSoC Emulator into Your Board* - AN2323.

## Ordering Information

### Key Device Features

The following table lists the CY8CLED04 EZ-Color device key package features and ordering codes.

**Table 31. Device Key Features and Ordering Information**

Package	Ordering Code	Flash (Bytes)	SRAM (Bytes)	Temperature Range	Digital Blocks	Analog Blocks	Digital I/O Pins	Analog Inputs	Analog Outputs	XRES Pin
68-pin (8 x 8 mm) Sawn	CY8CLED04-68LTXI	16 K	1 K	-40 °C to +85 °C	4	6	56	48	2	Yes
68-pin (8 x 8 mm) Sawn (Tape and Reel)	CY8CLED04-68LTXIT	16 K	1 K	-40 °C to +85 °C	4	6	56	48	2	Yes

### Ordering Code Definitions

CY 8 C LED xx - xx xxxx

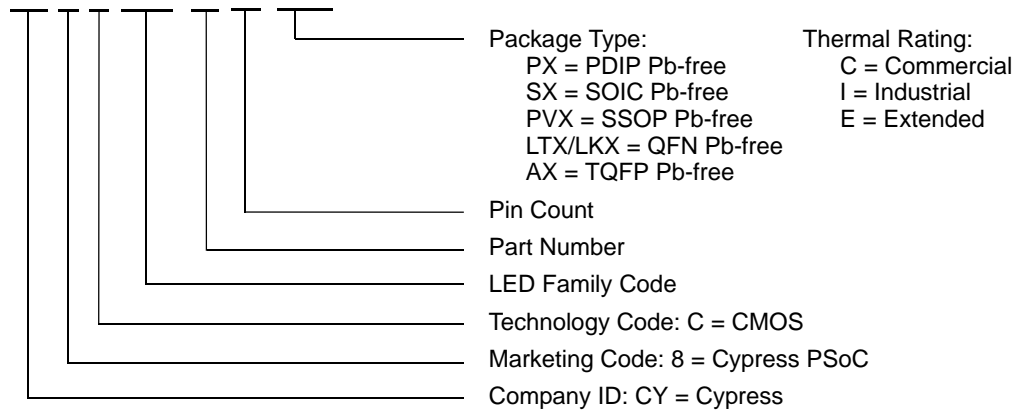

#### Notes

- 16. Flex-Pod kit includes a practice flex-pod and a practice PCB, in addition to two flex-pods.
- 17. Programming adapter converts non-DIP package to DIP footprint. Specific details and ordering information for each of the adapters can be found at <http://www.emulation.com>.

## Acronyms

### Acronyms Used

The following table lists the acronyms that are used in this document.

Acronym	Description	Acronym	Description
AC	alternating current	MAC	multiply-accumulate
ADC	analog-to-digital converter	MIPS	million instructions per second
API	application programming interface	PCB	printed circuit board
CMOS	complementary metal oxide semiconductor	PDIP	plastic dual-in-line package
CPU	central processing unit	PGA	programmable gain amplifier
CRC	cyclic redundancy check	POR	power-on reset
CT	continuous time	PPOR	precision power-on reset
DAC	digital-to-analog converter	PRS	pseudo-random sequence
DC	direct current	PrISM™	precise illumination signal modulation
DTMF	dual-tone multi-frequency	PSoC®	Programmable System-on-Chip™
EEPROM	electrically erasable programmable read-only memory	PWM	pulse-width modulator
GPIO	general purpose I/O	QFN	quad flat no leads
I/O	input/output	SAR	successive approximation register
ICE	in-circuit emulator	SRAM	static random-access memory
IDE	integrated development environment	SC	switched capacitor
ILO	internal low speed oscillator	SLIMO	slow IMO
IMO	internal main oscillator	SOIC	small-outline integrated circuit
IrDA	infrared data association	SPI™	serial peripheral interface
ISSP	In-System Serial Programming	SROM	supervisory read-only memory
LCD	liquid crystal display	UART	universal asynchronous receiver / transmitter
LED	light-emitting diode	USB	universal serial bus
LPC	low power comparator	WDT	watchdog timer
LVD	low-voltage detect	XRES	external reset

## Reference Documents

*Design Aids – Reading and Writing PSoC® Flash – AN2015* (001-40459)

*Understanding Datasheet Jitter Specifications for Cypress Timing Products – AN5054* (001-14503)

*Application Notes for Surface Mount Assembly of Amkor's MicroLeadFrame (MLF) Packages* – available at <http://www.amkor.com>

## Document Conventions

### Units of Measure

Symbol	Unit of Measure	Symbol	Unit of Measure
°C	degree Celsius	mV	millivolts
dB	decibels	mVpp	millivolts peak-to-peak
fF	femtofarads	nA	nanoamperes
kHz	kilohertz	ns	nanoseconds
kΩ	kilohm	nV	nanovolts
MHz	megahertz	pA	picoamperes
μA	microamperes	pF	picofarads
μs	microseconds	ps	picoseconds
μV	microvolts	%	percent
mA	milliamperes	rt-Hz	root hertz
mm	millimeter	V	volts
ms	milliseconds	W	watts

### Numeric Conventions

Hexadecimal numbers are represented with all letters in uppercase with an appended lowercase 'h' (for example, '14h' or '3Ah'). Hexadecimal numbers may also be represented by a '0x' prefix, the C coding convention. Binary numbers have an appended lowercase 'b' (for example, '01010100b' or '01000011b'). Numbers not indicated by an 'h' or 'b' are decimal.

### Glossary

active high	<ol style="list-style-type: none"> <li>5. A logic signal having its asserted state as the logic 1 state.</li> <li>6. A logic signal having the logic 1 state as the higher voltage of the two states.</li> </ol>
analog blocks	The basic programmable opamp circuits. These are switched capacitor (SC) and continuous time (CT) blocks. These blocks can be interconnected to provide ADCs, DACs, multi-pole filters, gain stages, and much more.
analog-to-digital (ADC)	A device that changes an analog signal to a digital signal of corresponding magnitude. Typically, an ADC converts a voltage to a digital number. The digital-to-analog (DAC) converter performs the reverse operation.
Application Programming Interface (API)	A series of software routines that comprise an interface between a computer application and lower level services and functions (for example, user modules and libraries). APIs serve as building blocks for programmers that create software applications.
asynchronous	A signal whose data is acknowledged or acted upon immediately, irrespective of any clock signal.
Bandgap reference	A stable voltage reference design that matches the positive temperature coefficient of $V_T$ with the negative temperature coefficient of $V_{BE}$ , to produce a zero temperature coefficient (ideally) reference.
bandwidth	<ol style="list-style-type: none"> <li>1. The frequency range of a message or information processing system measured in hertz.</li> <li>2. The width of the spectral region over which an amplifier (or absorber) has substantial gain (or loss); it is sometimes represented more specifically as, for example, full width at half maximum.</li> </ol>
bias	<ol style="list-style-type: none"> <li>1. A systematic deviation of a value from a reference value.</li> <li>2. The amount by which the average of a set of values departs from a reference value.</li> <li>3. The electrical, mechanical, magnetic, or other force (field) applied to a device to establish a reference level to operate the device.</li> </ol>

## Glossary (continued)

block	<ol style="list-style-type: none"><li>1. A functional unit that performs a single function, such as an oscillator.</li><li>2. A functional unit that may be configured to perform one of several functions, such as a digital PSoC block or an analog PSoC block.</li></ol>
buffer	<ol style="list-style-type: none"><li>1. A storage area for data that is used to compensate for a speed difference, when transferring data from one device to another. Usually refers to an area reserved for IO operations, into which data is read, or from which data is written.</li><li>2. A portion of memory set aside to store data, often before it is sent to an external device or as it is received from an external device.</li><li>3. An amplifier used to lower the output impedance of a system.</li></ol>
bus	<ol style="list-style-type: none"><li>1. A named connection of nets. Bundling nets together in a bus makes it easier to route nets with similar routing patterns.</li><li>2. A set of signals performing a common function and carrying similar data. Typically represented using vector notation; for example, address[7:0].</li><li>3. One or more conductors that serve as a common connection for a group of related devices.</li></ol>
clock	The device that generates a periodic signal with a fixed frequency and duty cycle. A clock is sometimes used to synchronize different logic blocks.
comparator	An electronic circuit that produces an output voltage or current whenever two input levels simultaneously satisfy predetermined amplitude requirements.
compiler	A program that translates a high level language, such as C, into machine language.
configuration space	In PSoC devices, the register space accessed when the XIO bit, in the CPU_F register, is set to '1'.
crystal oscillator	An oscillator in which the frequency is controlled by a piezoelectric crystal. Typically a piezoelectric crystal is less sensitive to ambient temperature than other circuit components.
cyclic redundancy check (CRC)	A calculation used to detect errors in data communications, typically performed using a linear feedback shift register. Similar calculations may be used for a variety of other purposes such as data compression.
data bus	A bi-directional set of signals used by a computer to convey information from a memory location to the central processing unit and vice versa. More generally, a set of signals used to convey data between digital functions.
debugger	A hardware and software system that allows the user to analyze the operation of the system under development. A debugger usually allows the developer to step through the firmware one step at a time, set break points, and analyze memory.
dead band	A period of time when neither of two or more signals are in their active state or in transition.
digital blocks	The 8-bit logic blocks that can act as a counter, timer, serial receiver, serial transmitter, CRC generator, pseudo-random number generator, or SPI.
digital-to-analog (DAC)	A device that changes a digital signal to an analog signal of corresponding magnitude. The analog-to-digital (ADC) converter performs the reverse operation.
duty cycle	The relationship of a clock period high time to its low time, expressed as a percent.

## Glossary (continued)

emulator	Duplicates (provides an emulation of) the functions of one system with a different system, so that the second system appears to behave like the first system.
external reset (XRES)	An active high signal that is driven into the PSoC device. It causes all operation of the CPU and blocks to stop and return to a pre-defined state.
flash	An electrically programmable and erasable, non-volatile technology that provides users with the programmability and data storage of EPROMs, plus in-system erasability. Non-volatile means that the data is retained when power is off.
Flash block	The smallest amount of Flash ROM space that may be programmed at one time and the smallest amount of Flash space that may be protected. A Flash block holds 64 bytes.
frequency	The number of cycles or events per unit of time, for a periodic function.
gain	The ratio of output current, voltage, or power to input current, voltage, or power, respectively. Gain is usually expressed in dB.
I <sup>2</sup> C	A two-wire serial computer bus by Philips Semiconductors (now NXP Semiconductors). I <sup>2</sup> C is an Inter-Integrated Circuit. It is used to connect low-speed peripherals in an embedded system. The original system was created in the early 1980s as a battery control interface, but it was later used as a simple internal bus system for building control electronics. I <sup>2</sup> C uses only two bi-directional pins, clock and data, both running at +5V and pulled high with resistors. The bus operates at 100 kbits/second in standard mode and 400 kbits/second in fast mode.
ICE	The in-circuit emulator that allows users to test the project in a hardware environment, while viewing the debugging device activity in a software environment (PSoC Designer).
input/output (I/O)	A device that introduces data into or extracts data from a system.
interrupt	A suspension of a process, such as the execution of a computer program, caused by an event external to that process, and performed in such a way that the process can be resumed.
interrupt service routine (ISR)	A block of code that normal code execution is diverted to when the M8C receives a hardware interrupt. Many interrupt sources may each exist with its own priority and individual ISR code block. Each ISR code block ends with the RETI instruction, returning the device to the point in the program where it left normal program execution.
jitter	<ol style="list-style-type: none"><li>1. A misplacement of the timing of a transition from its ideal position. A typical form of corruption that occurs on serial data streams.</li><li>2. The abrupt and unwanted variations of one or more signal characteristics, such as the interval between successive pulses, the amplitude of successive cycles, or the frequency or phase of successive cycles.</li></ol>
low-voltage detect (LVD)	A circuit that senses V <sub>DD</sub> and provides an interrupt to the system when V <sub>DD</sub> falls lower than a selected threshold.
M8C	An 8-bit Harvard-architecture microprocessor. The microprocessor coordinates all activity inside a PSoC by interfacing to the flash, SRAM, and register space.
master device	A device that controls the timing for data exchanges between two devices. Or when devices are cascaded in width, the master device is the one that controls the timing for data exchanges between the cascaded devices and an external interface. The controlled device is called the <i>slave device</i> .

## Glossary (continued)

microcontroller	An integrated circuit chip that is designed primarily for control systems and products. In addition to a CPU, a microcontroller typically includes memory, timing circuits, and IO circuitry. The reason for this is to permit the realization of a controller with a minimal quantity of chips, thus achieving maximal possible miniaturization. This in turn, reduces the volume and the cost of the controller. The microcontroller is normally not used for general-purpose computation as is a microprocessor.
mixed-signal	The reference to a circuit containing both analog and digital techniques and components.
modulator	A device that imposes a signal on a carrier.
noise	<ol style="list-style-type: none"><li>1. A disturbance that affects a signal and that may distort the information carried by the signal.</li><li>2. The random variations of one or more characteristics of any entity such as voltage, current, or data.</li></ol>
oscillator	A circuit that may be crystal controlled and is used to generate a clock frequency.
parity	A technique for testing transmitting data. Typically, a binary digit is added to the data to make the sum of all the digits of the binary data either always even (even parity) or always odd (odd parity).
phase-locked loop (PLL)	An electronic circuit that controls an <i>oscillator</i> so that it maintains a constant phase angle relative to a reference signal.
pinouts	The pin number assignment: the relation between the logical inputs and outputs of the PSoC device and their physical counterparts in the printed circuit board (PCB) package. Pinouts involve pin numbers as a link between schematic and PCB design (both being computer generated files) and may also involve pin names.
port	A group of pins, usually eight.
power-on reset (POR)	A circuit that forces the PSoC device to reset when the voltage is lower than a pre-set level. This is one type of hardware reset.
PSoC®	Cypress Semiconductor's PSoC® is a registered trademark and Programmable System-on-Chip™ is a trademark of Cypress.
PSoC Designer™	The software for Cypress' Programmable System-on-Chip technology.
pulse-width modulator (PWM)	An output in the form of duty cycle which varies as a function of the applied measurand
RAM	An acronym for random access memory. A data-storage device from which data can be read out and new data can be written in.
register	A storage device with a specific capacity, such as a bit or byte.
reset	A means of bringing a system back to a know state. See hardware reset and software reset.
ROM	An acronym for read only memory. A data-storage device from which data can be read out, but new data cannot be written in.
serial	<ol style="list-style-type: none"><li>1. Pertaining to a process in which all events occur one after the other.</li><li>2. Pertaining to the sequential or consecutive occurrence of two or more related activities in a single device or channel.</li></ol>

## Glossary (continued)

settling time	The time it takes for an output signal or value to stabilize after the input has changed from one value to another.
shift register	A memory storage device that sequentially shifts a word either left or right to output a stream of serial data.
slave device	A device that allows another device to control the timing for data exchanges between two devices. Or when devices are cascaded in width, the slave device is the one that allows another device to control the timing of data exchanges between the cascaded devices and an external interface. The controlling device is called the master device.
SRAM	An acronym for static random access memory. A memory device allowing users to store and retrieve data at a high rate of speed. The term static is used because, after a value has been loaded into an SRAM cell, it remains unchanged until it is explicitly altered or until power is removed from the device.
SROM	An acronym for supervisory read only memory. The SROM holds code that is used to boot the device, calibrate circuitry, and perform flash operations. The functions of the SROM may be accessed in normal user code, operating from flash.
stop bit	A signal following a character or block that prepares the receiving device to receive the next character or block.
synchronous	<ol style="list-style-type: none"><li>1. A signal whose data is not acknowledged or acted upon until the next active edge of a clock signal.</li><li>2. A system whose operation is synchronized by a clock signal.</li></ol>
tri-state	A function whose output can adopt three states: 0, 1, and Z (high-impedance). The function does not drive any value in the Z state and, in many respects, may be considered to be disconnected from the rest of the circuit, allowing another output to drive the same net.
UART	A UART or universal asynchronous receiver-transmitter translates between parallel bits of data and serial bits.
user modules	Pre-build, pre-tested hardware/firmware peripheral functions that take care of managing and configuring the lower level Analog and Digital PSoC Blocks. User Modules also provide high level <i>API</i> for the peripheral function.
user space	The bank 0 space of the register map. The registers in this bank are more likely to be modified during normal program execution and not just during initialization. Registers in bank 1 are most likely to be modified only during the initialization phase of the program.
$V_{DD}$	A name for a power net meaning "voltage drain." The most positive power supply signal. Usually 5 V or 3.3 V.
$V_{SS}$	A name for a power net meaning "voltage source." The most negative power supply signal.
watchdog timer	A timer that must be serviced periodically. If it is not serviced, the CPU resets after a specified period of time.

Document History Page

Document Title: CY8CLED04 EZ-Color™ HB LED Controller				
Document Number: 001-13108				
Rev.	ECN No.	Orig. of Change	Submission Date	Description of Change
**	1148504	SFVTMP3	See ECN	New document.
*A	2657959	DPT/PYRS	02/11/2009	Added package diagram 001-09618 and updated Ordering Information table
*B	2794355	XBM	10/28/2009	Added "Contents" on page 3. Updated "Development Tools" on page 7. Corrected FCPU1 and FCPU2 parameters in "AC Chip-Level Specifications" on page 29.
*C	2850593	FRE/DSG/HMT	01/14/2010	Removed pruned/obsolete parts (CY8CLED04-68LFXI). Updated DC GPIO, AC Chip-Level, and AC Programming Specifications as follows: Modified TWRITE specifications. Replaced TRAMP time) specification with SRPOWER_UP (slew rate) specification. Added note to Flash Endurance specification. Added IOH, IOL, DCILO, F32K_U, TPOWERUP, TERASEALL, TPROGRAM_HOT, and TPROGRAM_COLD specifications. Corrected the Pod Kit part numbers. Updated Development Tools. Updated copyright and Sales, Solutions, and Legal Information URLs. Updated 68-Pin QFN (Sawn Type) package diagram.
*D	2900748	CGX	03/31/2010	Removed inactive parts from Ordering Information table. Added active parts in Ordering Information table.
*E	3111560	NJF	12/15/10	Added DC I <sup>2</sup> C Specifications table. Added F <sub>32K_U</sub> max limit. Added Tjit_IMO specification, removed existing jitter specifications. Updated Units of Measure, Acronyms, Glossary, and References sections. Updated solder reflow specifications. No specific changes were made to AC Digital Block Specifications table and I <sup>2</sup> C Timing Diagram. They were updated for clearer understanding. Updated Figure 6 since the labelling for y-axis was incorrect. Template and styles update.
*F	3283777	DIVA	07/13/11	Updated Getting Started, Development Tools, and Designing with PSoC Designer. Removed obsolete kits. Removed reference to obsolete spec AN2012.

## Sales, Solutions, and Legal Information

### Worldwide Sales and Design Support

Cypress maintains a worldwide network of offices, solution centers, manufacturer's representatives, and distributors. To find the office closest to you, visit us at [Cypress Locations](#).

### Products

Automotive	<a href="http://cypress.com/go/automotive">cypress.com/go/automotive</a>
Clocks & Buffers	<a href="http://cypress.com/go/clocks">cypress.com/go/clocks</a>
Interface	<a href="http://cypress.com/go/interface">cypress.com/go/interface</a>
Lighting & Power Control	<a href="http://cypress.com/go/powerpsoc">cypress.com/go/powerpsoc</a> <a href="http://cypress.com/go/plc">cypress.com/go/plc</a>
Memory	<a href="http://cypress.com/go/memory">cypress.com/go/memory</a>
Optical & Image Sensing	<a href="http://cypress.com/go/image">cypress.com/go/image</a>
PSoC	<a href="http://cypress.com/go/psoc">cypress.com/go/psoc</a>
Touch Sensing	<a href="http://cypress.com/go/touch">cypress.com/go/touch</a>
USB Controllers	<a href="http://cypress.com/go/USB">cypress.com/go/USB</a>
Wireless/RF	<a href="http://cypress.com/go/wireless">cypress.com/go/wireless</a>

### PSoC® Solutions

[psoc.cypress.com/solutions](http://psoc.cypress.com/solutions)

PSoC 1 | PSoC 3 | PSoC 5

---



© Cypress Semiconductor Corporation, 2007- 2011. The information contained herein is subject to change without notice. Cypress Semiconductor Corporation assumes no responsibility for the use of any circuitry other than circuitry embodied in a Cypress product. Nor does it convey or imply any license under patent or other rights. Cypress products are not warranted nor intended to be used for medical, life support, life saving, critical control or safety applications, unless pursuant to an express written agreement with Cypress. Furthermore, Cypress does not authorize its products for use as critical components in life-support systems where a malfunction or failure may reasonably be expected to result in significant injury to the user. The inclusion of Cypress products in life-support systems application implies that the manufacturer assumes all risk of such use and in doing so indemnifies Cypress against all charges.

Any Source Code (software and/or firmware) is owned by Cypress Semiconductor Corporation (Cypress) and is protected by and subject to worldwide patent protection (United States and foreign), United States copyright laws and international treaty provisions. Cypress hereby grants to licensee a personal, non-exclusive, non-transferable license to copy, use, modify, create derivative works of, and compile the Cypress Source Code and derivative works for the sole purpose of creating custom software and or firmware in support of licensee product to be used only in conjunction with a Cypress integrated circuit as specified in the applicable agreement. Any reproduction, modification, translation, compilation, or representation of this Source Code except as specified above is prohibited without the express written permission of Cypress.





Disclaimer: CYPRESS MAKES NO WARRANTY OF ANY KIND, EXPRESS OR IMPLIED, WITH REGARD TO THIS MATERIAL, INCLUDING, BUT NOT LIMITED TO, THE IMPLIED WARRANTIES OF MERCHANTABILITY AND FITNESS FOR A PARTICULAR PURPOSE. Cypress reserves the right to make changes without further notice to the materials described herein. Cypress does not assume any liability arising out of the application or use of any product or circuit described herein. Cypress does not authorize its products for use as critical components in life-support systems where a malfunction or failure may reasonably be expected to result in significant injury to the user. The inclusion of Cypress' product in a life-support systems application implies that the manufacturer assumes all risk of such use and in doing so indemnifies Cypress

## Looking for pricing, stock, or lifecycle information?

Click below to explore more details on WIN SOURCE:

-  [View CY8CLED04-68LFXI on WIN SOURCE](#)
-  [Cypress Semiconductor Corp Information](#)

## Optimize Your Supply Chain with WIN SOURCE Solutions

-  Global Sourcing Solution
-  Obsolete Management
-  Cost Control Management
-  Shortage Management
-  Alternative Solution
-  Excess Inventory Management