



**THE DATASHEET OF
SN74ALS29854DWRE4**



SN74ALS29854 8-BIT TO 9-BIT PARITY BUS TRANSCEIVER

SDAS118C – FEBRUARY 1987 – REVISED JANUARY 1995

- Functionally Similar to AMD's AM29854
- High-Speed Bus Transceiver With Parity Generator/Checker
- Parity-Error Flag With Open-Collector Outputs
- Latch for Storing the Parity-Error Flag
- Package Options Include Plastic Small-Outline (DW) Packages and Standard Plastic (NT) 300-mil DIPs

DW OR NT PACKAGE
(TOP VIEW)

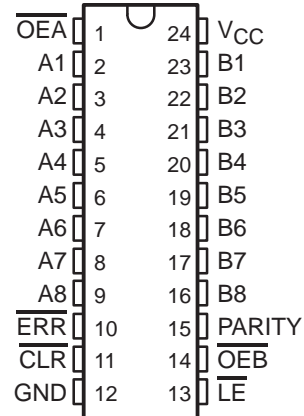

description

The SN74ALS29854 is an 8-bit to 9-bit parity transceiver designed for two-way communication between data buses. When data is transmitted from the A bus to the B bus, a parity bit is generated. When data is transmitted from the B bus to the A bus with its corresponding parity bit, the parity-error ($\overline{\text{ERR}}$) output indicates whether or not an error in the B data has occurred. The output-enable ($\overline{\text{OEA}}$, $\overline{\text{OEB}}$) inputs can be used to disable the device so that the buses are effectively isolated.

A 9-bit parity generator/checker generates a parity-odd (PARITY) output and monitors the parity of the I/O ports with an open-collector $\overline{\text{ERR}}$ flag. $\overline{\text{ERR}}$ can be either passed, sampled, stored, or cleared from the latch using the latch-enable ($\overline{\text{LE}}$) and clear (CLR) control inputs. When both $\overline{\text{OEA}}$ and $\overline{\text{OEB}}$ are low, data is transferred from the A bus to the B bus and inverted parity is generated. Inverted parity is a forced error condition that gives the designer more system diagnostic capability.

The SN74ALS29854 is characterized for operation from 0°C to 70°C.

FUNCTION TABLE

INPUTS						OUTPUT AND I/O				OPERATION
$\overline{\text{OEB}}$	$\overline{\text{OEA}}$	$\overline{\text{CLR}}$	$\overline{\text{LE}}$	Ai Σ of Hs	Bi† Σ of Ls	A	B	PARITY	$\overline{\text{ERR}}‡$	
L	H	X	X	Odd Even	NA	NA	$\overline{\text{A}}$	H L	NA	$\overline{\text{A}}$ data to B bus and generate parity
H	L	X	L	NA	Odd Even	$\overline{\text{B}}$	NA	NA	H L	$\overline{\text{B}}$ data to A bus and check parity
H	L	H	H	NA	X	X	NA	NA	N-1	Store error flag
X	X	L	H	X	X	X	NA	NA	H	Clear error-flag register
H	H	H L X X	H H L L	X X L Odd H Even	X	Z	Z	Z	NC H L H	Isolation§
L	L	X	X	Odd Even	NA	NA	$\overline{\text{A}}$	L H	NA	$\overline{\text{A}}$ data to B bus and generate inverted parity

NA = not applicable, NC = no change, X = don't care

† Summation of high-level inputs includes PARITY along with Bi inputs.

‡ Output states shown assume $\overline{\text{ERR}}$ was previously high.

§ In this mode, $\overline{\text{ERR}}$, when enabled, shows inverted parity of the A bus.

SN74ALS29854 8-BIT TO 9-BIT PARITY BUS TRANSCEIVER

SDAS118C – FEBRUARY 1987 – REVISED JANUARY 1995

logic diagram (positive logic)

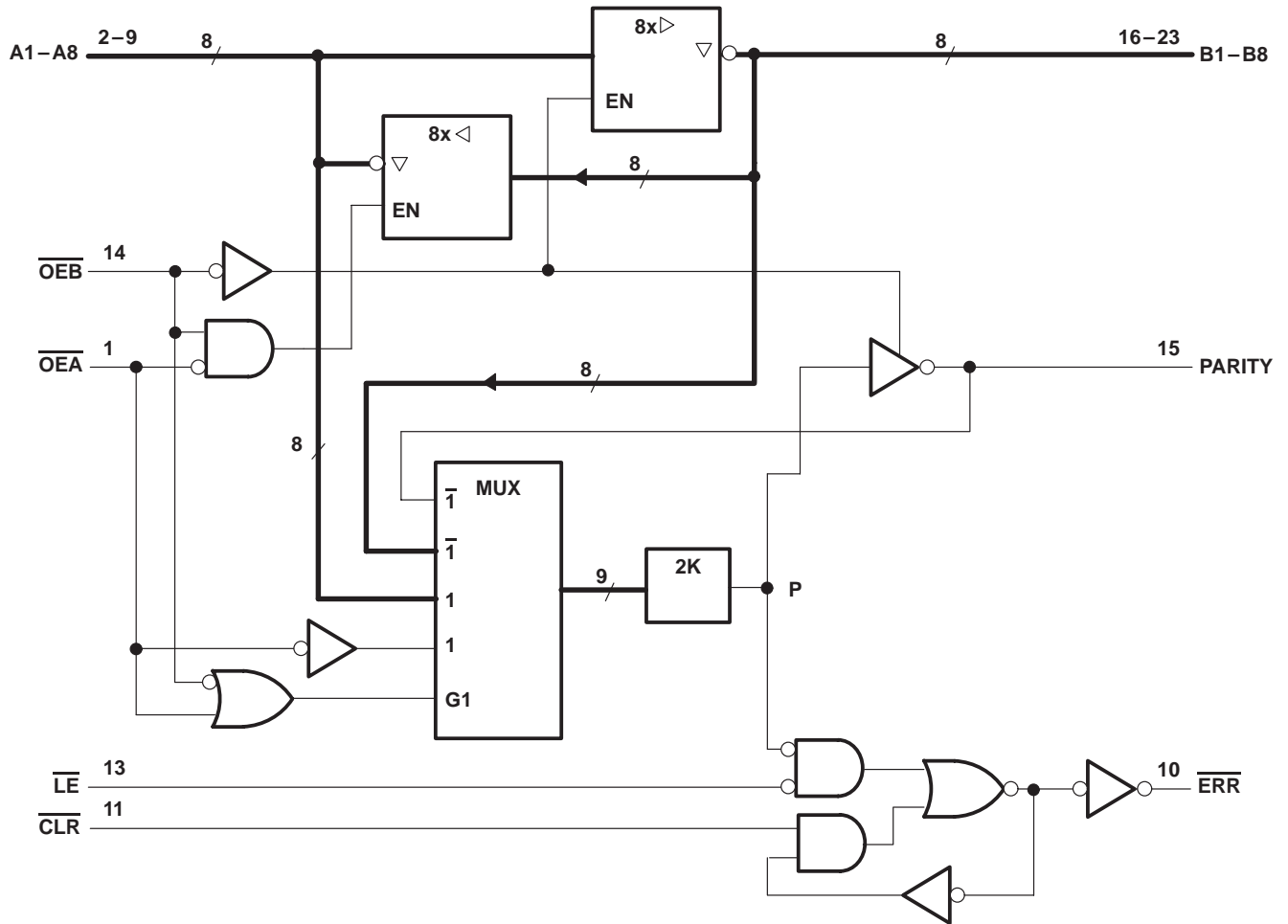

error-flag waveforms

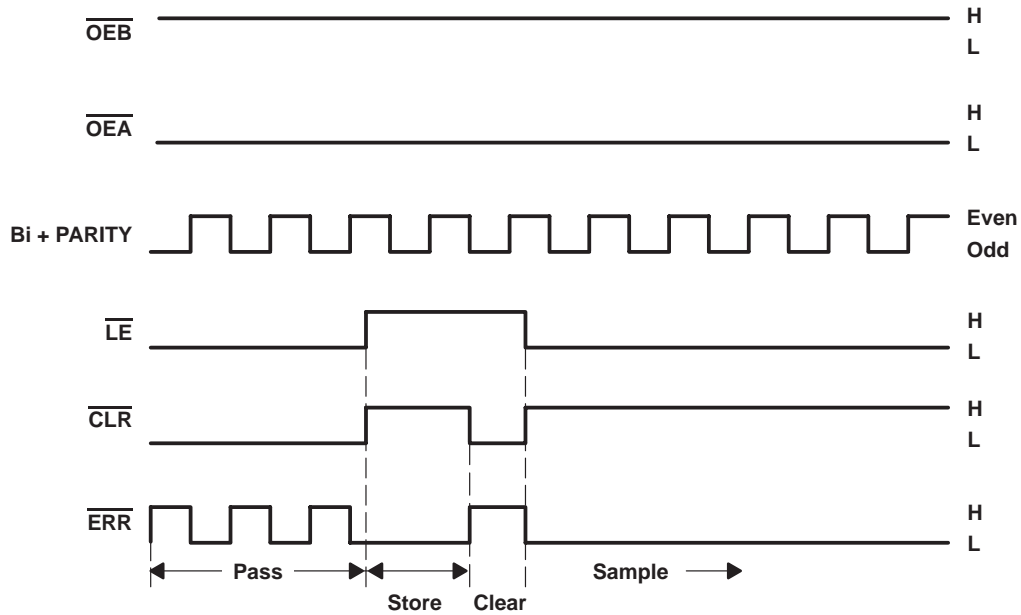

ERROR-FLAG FUNCTIONS

INPUTS		INTERNAL TO DEVICE	OUTPUT PRESTATE	OUTPUT	FUNCTION
\overline{LE}	\overline{CLR}	POINT P	$\overline{ERR}_{n-1}^\dagger$	\overline{ERR}	
L	L	L H	X	L H	Pass
L	H	L X H	X L H	L L H	Sample
H	L	X	X	H	Clear
H	H	X	L H	L H	Store

$^\dagger \overline{ERR}_{n-1}$ represents the state of \overline{ERR} before any changes at \overline{CLR} , \overline{LE} , or point P.

absolute maximum ratings over operating free-air temperature range (unless otherwise noted) ‡

- Supply voltage, V_{CC} 7 V
- Input voltage, V_I 7 V
- Voltage applied to a disabled I/O port 5.5 V
- Operating free-air temperature range, T_A 0°C to 70°C
- Storage temperature range -65°C to 150°C

‡ Stresses beyond those listed under "absolute maximum ratings" may cause permanent damage to the device. These are stress ratings only, and functional operation of the device at these or any other conditions beyond those indicated under "recommended operating conditions" is not implied. Exposure to absolute-maximum-rated conditions for extended periods may affect device reliability.

SN74ALS29854

8-BIT TO 9-BIT PARITY BUS TRANSCEIVER

SDAS118C – FEBRUARY 1987 – REVISED JANUARY 1995

recommended operating conditions

		MIN	NOM	MAX	UNIT
V _{CC}	Supply voltage	4.75	5	5.25	V
V _{IH}	High-level input voltage	2			V
V _{IL}	Low-level input voltage			0.8	V
V _{OH}	High-level output voltage, $\overline{\text{ERR}}$			5.5	V
I _{OH}	High-level output current			-24	mA
I _{OL}	Low-level output current			48	mA
t _w	Pulse duration	$\overline{\text{LE}}$ high	10		ns
		$\overline{\text{LE}}$ low	10		
		$\overline{\text{CLR}}$ low	10		
t _{su}	Setup time before $\overline{\text{LE}}\downarrow$	Bi and PARITY	10		ns
		$\overline{\text{CLR}}$ high	15		
t _h	Hold time, Bi and PARITY after $\overline{\text{LE}}\downarrow$	3			ns
T _A	Operating free-air temperature	0		70	°C

electrical characteristics over recommended operating free-air temperature range (unless otherwise noted)

PARAMETER		TEST CONDITIONS		MIN	TYP†	MAX	UNIT
V _{IK}		V _{CC} = 4.75 V,	I _I = -18 mA			-1.2	V
V _{OH}	All I/Os except $\overline{\text{ERR}}$	V _{CC} = 4.75 V	I _{OH} = -15 mA	2.4			V
			I _{OH} = -24 mA	2			
I _{OH}	$\overline{\text{ERR}}$	V _{CC} = 4.75 V,	V _{OH} = 5.5 V			0.1	mA
V _{OL}		V _{CC} = 4.75 V,	I _{OL} = 48 mA	0.35	0.5		V
I _I		V _{CC} = 5.25 V,	V _I = 5.5 V			0.1	mA
I _{IH} ‡		V _{CC} = 5.25 V,	V _I = 2.7 V			20	μA
I _{IL} ‡	Data	V _{CC} = 5.25 V,	V _I = 0.4 V			-0.2	mA
	Control					-0.75	
I _O §		V _{CC} = 5.25 V,	V _O = 0	-75		-250	mA
I _{CC}		V _{CC} = 5.25 V,	All outputs open		70	100	mA

† All typical values are at V_{CC} = 5 V, T_A = 25°C.

‡ For I/O ports, the parameters I_{IH} and I_{IL} include the off-state output current.

§ The output conditions have been chosen to produce a current that closely approximates one-half of the true short-circuit output current, I_{OS}.



SN74ALS29854 8-BIT TO 9-BIT PARITY BUS TRANSCEIVER

SDAS118C – FEBRUARY 1987 – REVISED JANUARY 1995

switching characteristics (see Figure 1)

PARAMETER	FROM (INPUT)	TO (OUTPUT)	TEST CONDITIONS	$V_{CC} = 4.75 \text{ V to } 5.25 \text{ V},$ $T_A = \text{MIN to MAX}^\dagger$		UNIT
				MIN	MAX	
t _{PLH}	A or B	B or A	$C_L = 50 \text{ pF}$	8		ns
t _{PHL}				8		
t _{PLH}	A or B	B or A	$C_L = 300 \text{ pF}$	13		ns
t _{PHL}				13		
t _{PLH}	A	PARITY	$C_L = 50 \text{ pF}$	15		ns
t _{PHL}				18		
t _{PLH}	A	PARITY	$C_L = 300 \text{ pF}$	22		ns
t _{PHL}				22		
t _{PZH}	$\overline{OE}A$ or $\overline{OE}B$	A or B	$C_L = 50 \text{ pF}$	17		ns
t _{PZL}				17		
t _{PZH}	$\overline{OE}A$ or $\overline{OE}B$	A or B	$C_L = 300 \text{ pF}$	23		ns
t _{PZL}				23		
t _{PHZ}	$\overline{OE}A$ or $\overline{OE}B$	A or B	$C_L = 5 \text{ pF}$	8		ns
t _{PLZ}				8		
t _{PHZ}	$\overline{OE}A$ or $\overline{OE}B$	A or B	$C_L = 50 \text{ pF}$	15		ns
t _{PLZ}				8		
t _{PHL}	\overline{LE}	\overline{ERR}	$C_L = 50 \text{ pF}$	12		ns
t _{PLH}	\overline{CLR}	\overline{ERR}	$C_L = 50 \text{ pF}$	12		ns
t _{PLH}	$\overline{OE}A$	PARITY	$C_L = 50 \text{ pF}$	17		ns
t _{PHL}				19		
t _{PLH}	$\overline{OE}A$	PARITY	$C_L = 300 \text{ pF}$	22		ns
t _{PHL}				25		
t _{PLH}	Bi/PARITY	\overline{ERR}	$C_L = 50 \text{ pF}$	20		ns
t _{PHL}				20		

† For conditions shown as MIN or MAX, use the appropriate value specified under recommended operating conditions.

SN74ALS29854 8-BIT TO 9-BIT PARITY BUS TRANSCEIVER

SDAS118C – FEBRUARY 1987 – REVISED JANUARY 1995

PARAMETER MEASUREMENT INFORMATION

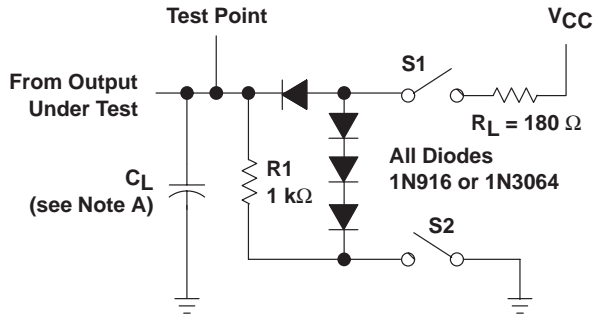

LOAD CIRCUIT 1
ALL OUTPUTS EXCEPT FOR ERROR FLAG

SWITCH POSITION TABLE		
TEST	S1	S2
t _{PLH}	Closed	Closed
t _{PHL}	Closed	Closed
t _{PZH}	Open	Closed
t _{PZL}	Closed	Open
t _{PHZ}	Closed	Closed
t _{PLZ}	Closed	Closed

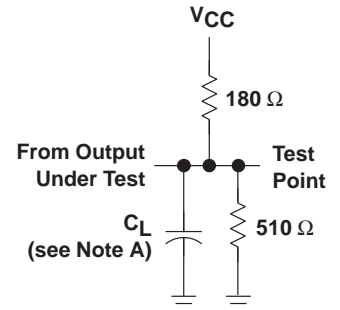

LOAD CIRCUIT 2
ERROR-FLAG OUTPUT

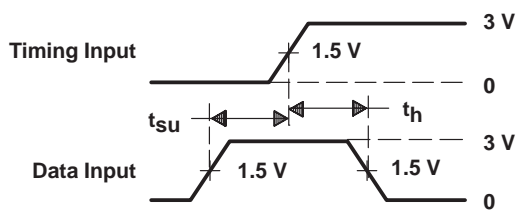

VOLTAGE WAVEFORMS
SETUP AND HOLD TIMES

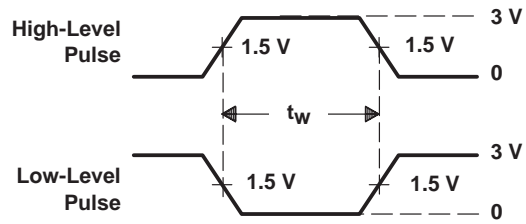

VOLTAGE WAVEFORMS
PULSE DURATIONS

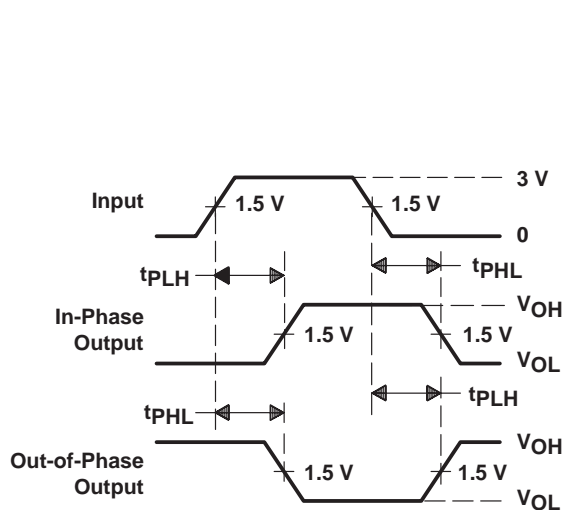

VOLTAGE WAVEFORMS
PROPAGATION DELAY TIMES

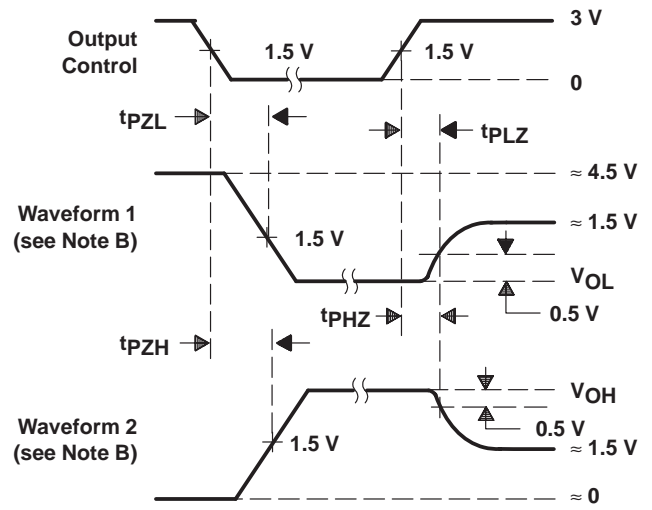

VOLTAGE WAVEFORMS
ENABLE AND DISABLE TIMES, 3-STATE OUTPUTS

- NOTES: A. C_L includes probe and jig capacitance.
 B. Waveform 1 is for an output with internal conditions such that the output is low except when disabled by the output control. Waveform 2 is for an output with internal conditions such that the output is high except when disabled by the output control.
 C. All input pulses are supplied by generators having the following characteristics: $PRR \leq 10$ MHz, $Z_O = 50 \Omega$, $t_r \leq 2.5$ ns, $t_f \leq 2.5$ ns.

Figure 1. Load Circuits and Voltage Waveforms

PACKAGING INFORMATION

Orderable Device	Status ⁽¹⁾	Package Type	Package Drawing	Pins	Package Qty	Eco Plan ⁽²⁾	Lead/Ball Finish	MSL Peak Temp ⁽³⁾
SN74ALS29854DW	ACTIVE	SOIC	DW	24	25	Green (RoHS & no Sb/Br)	CU NIPDAU	Level-1-260C-UNLIM
SN74ALS29854DWE4	ACTIVE	SOIC	DW	24	25	Green (RoHS & no Sb/Br)	CU NIPDAU	Level-1-260C-UNLIM
SN74ALS29854DWG4	ACTIVE	SOIC	DW	24	25	Green (RoHS & no Sb/Br)	CU NIPDAU	Level-1-260C-UNLIM
SN74ALS29854DWR	ACTIVE	SOIC	DW	24	2000	Green (RoHS & no Sb/Br)	CU NIPDAU	Level-1-260C-UNLIM
SN74ALS29854DWRE4	ACTIVE	SOIC	DW	24	2000	Green (RoHS & no Sb/Br)	CU NIPDAU	Level-1-260C-UNLIM
SN74ALS29854DWRG4	ACTIVE	SOIC	DW	24	2000	Green (RoHS & no Sb/Br)	CU NIPDAU	Level-1-260C-UNLIM
SN74ALS29854NT	ACTIVE	PDIP	NT	24	15	Pb-Free (RoHS)	CU NIPDAU	N / A for Pkg Type
SN74ALS29854NT3	OBSOLETE	PDIP	NT	24		TBD	Call TI	Call TI
SN74ALS29854NTE4	ACTIVE	PDIP	NT	24	15	Pb-Free (RoHS)	CU NIPDAU	N / A for Pkg Type

⁽¹⁾ The marketing status values are defined as follows:

ACTIVE: Product device recommended for new designs.

LIFEBUY: TI has announced that the device will be discontinued, and a lifetime-buy period is in effect.

NRND: Not recommended for new designs. Device is in production to support existing customers, but TI does not recommend using this part in a new design.

PREVIEW: Device has been announced but is not in production. Samples may or may not be available.

OBSOLETE: TI has discontinued the production of the device.

⁽²⁾ Eco Plan - The planned eco-friendly classification: Pb-Free (RoHS), Pb-Free (RoHS Exempt), or Green (RoHS & no Sb/Br) - please check <http://www.ti.com/productcontent> for the latest availability information and additional product content details.

TBD: The Pb-Free/Green conversion plan has not been defined.

Pb-Free (RoHS): TI's terms "Lead-Free" or "Pb-Free" mean semiconductor products that are compatible with the current RoHS requirements for all 6 substances, including the requirement that lead not exceed 0.1% by weight in homogeneous materials. Where designed to be soldered at high temperatures, TI Pb-Free products are suitable for use in specified lead-free processes.

Pb-Free (RoHS Exempt): This component has a RoHS exemption for either 1) lead-based flip-chip solder bumps used between the die and package, or 2) lead-based die adhesive used between the die and leadframe. The component is otherwise considered Pb-Free (RoHS compatible) as defined above.

Green (RoHS & no Sb/Br): TI defines "Green" to mean Pb-Free (RoHS compatible), and free of Bromine (Br) and Antimony (Sb) based flame retardants (Br or Sb do not exceed 0.1% by weight in homogeneous material)

⁽³⁾ MSL, Peak Temp. -- The Moisture Sensitivity Level rating according to the JEDEC industry standard classifications, and peak solder temperature.

Important Information and Disclaimer:The information provided on this page represents TI's knowledge and belief as of the date that it is provided. TI bases its knowledge and belief on information provided by third parties, and makes no representation or warranty as to the accuracy of such information. Efforts are underway to better integrate information from third parties. TI has taken and continues to take reasonable steps to provide representative and accurate information but may not have conducted destructive testing or chemical analysis on incoming materials and chemicals. TI and TI suppliers consider certain information to be proprietary, and thus CAS numbers and other limited information may not be available for release.

In no event shall TI's liability arising out of such information exceed the total purchase price of the TI part(s) at issue in this document sold by TI to Customer on an annual basis.

TAPE AND REEL BOX INFORMATION

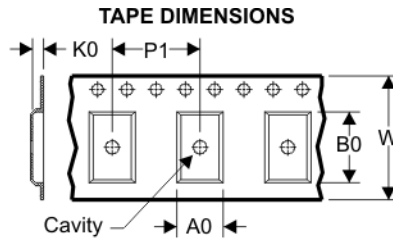

A0	Dimension designed to accommodate the component width
B0	Dimension designed to accommodate the component length
K0	Dimension designed to accommodate the component thickness
W	Overall width of the carrier tape
P1	Pitch between successive cavity centers

QUADRANT ASSIGNMENTS FOR PIN 1 ORIENTATION IN TAPE

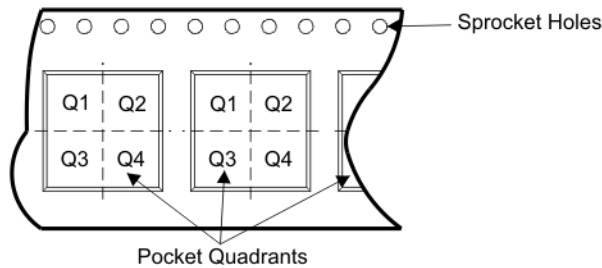

Device	Package	Pins	Site	Reel Diameter (mm)	Reel Width (mm)	A0 (mm)	B0 (mm)	K0 (mm)	P1 (mm)	W (mm)	Pin1 Quadrant
SN74ALS29854DWR	DW	24	SITE 60	330	24	10.75	15.7	2.7	12	24	Q1

TAPE AND REEL BOX DIMENSIONS



Device	Package	Pins	Site	Length (mm)	Width (mm)	Height (mm)
SN74ALS29854DWR	DW	24	SITE 60	346.0	346.0	41.0

NT (R-PDIP-T**)

PLASTIC DUAL-IN-LINE PACKAGE

24 PINS SHOWN

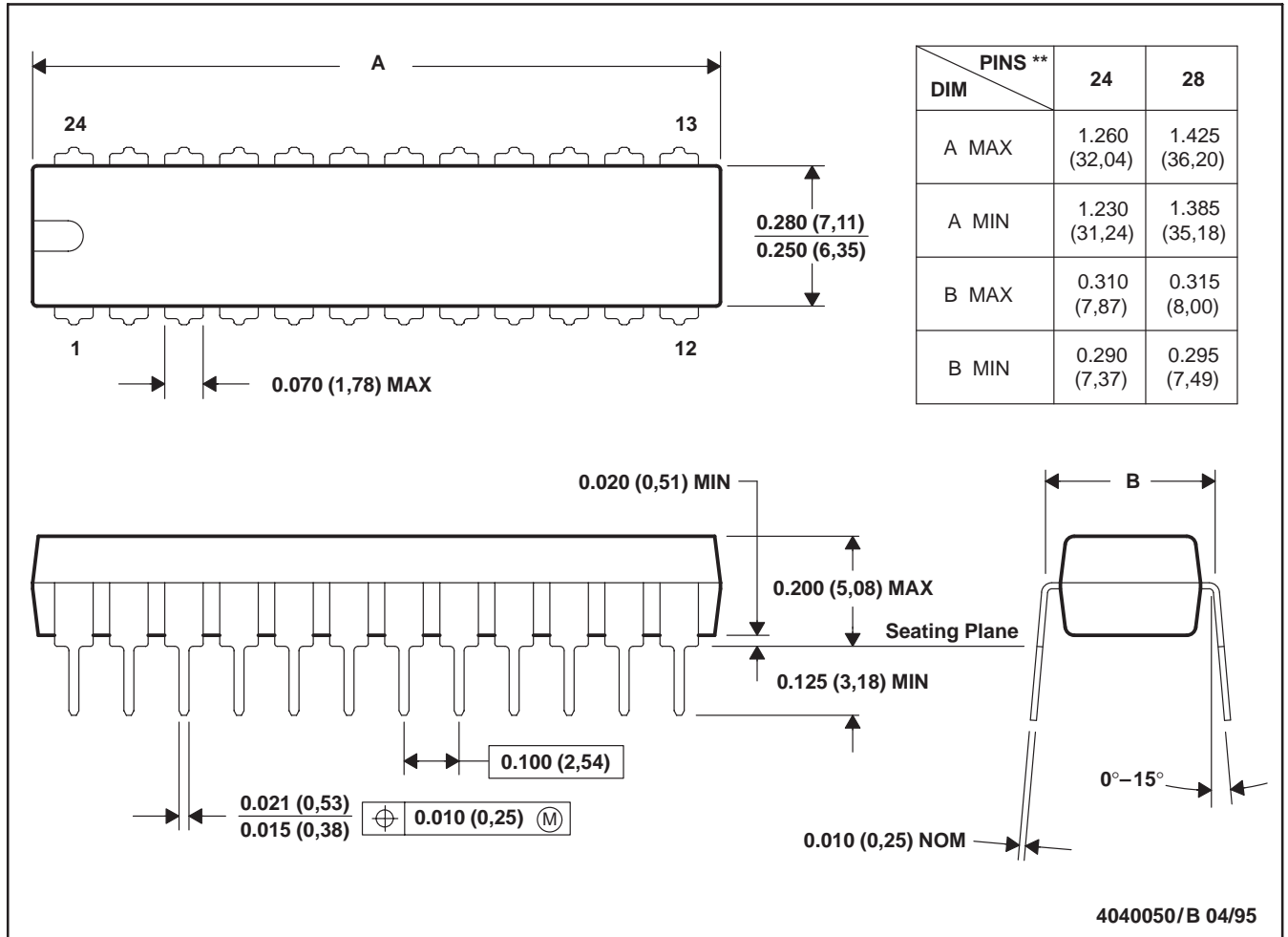

- NOTES: A. All linear dimensions are in inches (millimeters).
 B. This drawing is subject to change without notice.

DW (R-PDSO-G24)

PLASTIC SMALL-OUTLINE PACKAGE

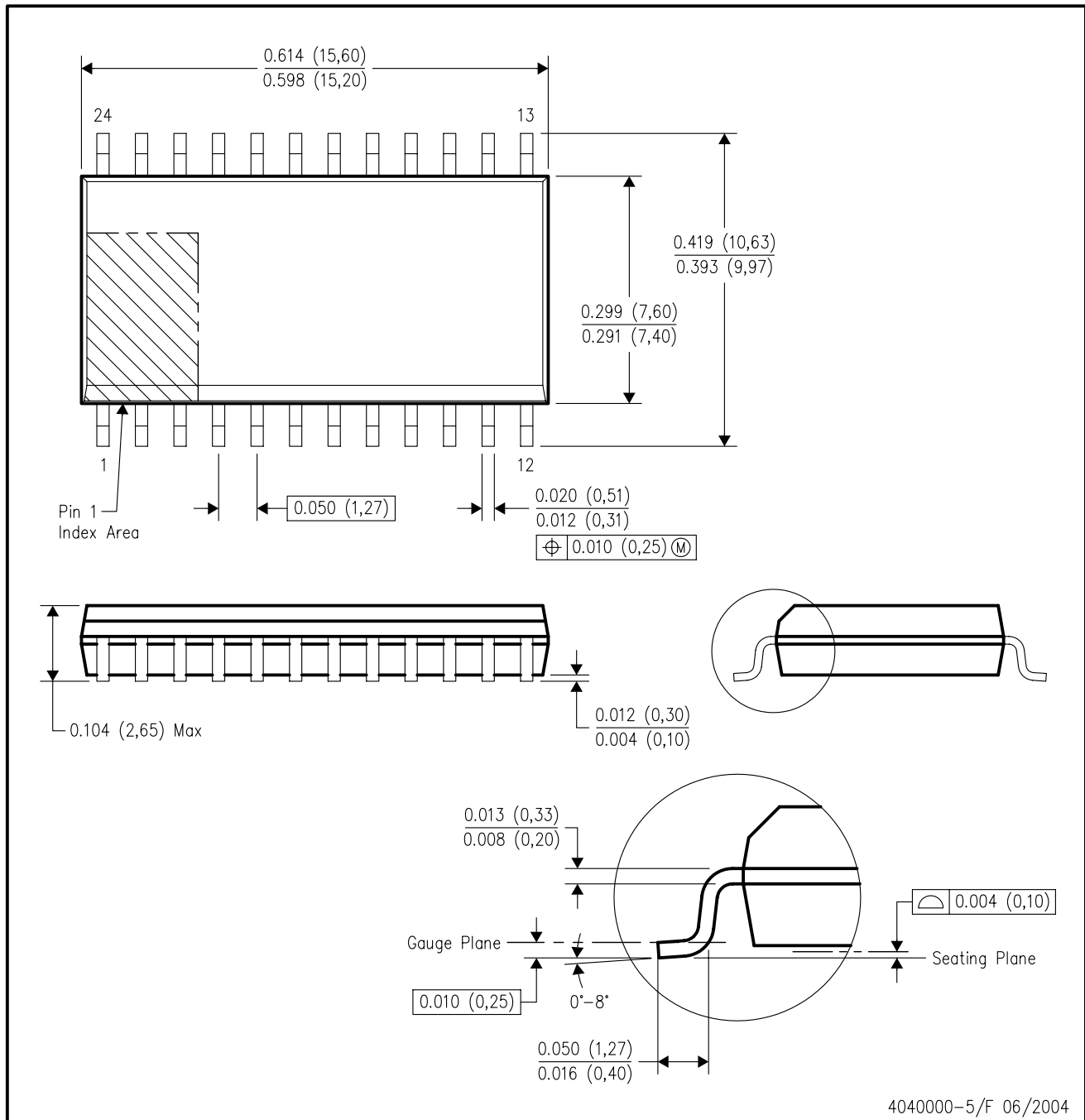

- NOTES:
- A. All linear dimensions are in inches (millimeters).
 - B. This drawing is subject to change without notice.
 - C. Body dimensions do not include mold flash or protrusion not to exceed 0.006 (0,15).
 - D. Falls within JEDEC MS-013 variation AD.

IMPORTANT NOTICE

Texas Instruments Incorporated and its subsidiaries (TI) reserve the right to make corrections, modifications, enhancements, improvements, and other changes to its products and services at any time and to discontinue any product or service without notice. Customers should obtain the latest relevant information before placing orders and should verify that such information is current and complete. All products are sold subject to TI's terms and conditions of sale supplied at the time of order acknowledgment.

TI warrants performance of its hardware products to the specifications applicable at the time of sale in accordance with TI's standard warranty. Testing and other quality control techniques are used to the extent TI deems necessary to support this warranty. Except where mandated by government requirements, testing of all parameters of each product is not necessarily performed.

TI assumes no liability for applications assistance or customer product design. Customers are responsible for their products and applications using TI components. To minimize the risks associated with customer products and applications, customers should provide adequate design and operating safeguards.

TI does not warrant or represent that any license, either express or implied, is granted under any TI patent right, copyright, mask work right, or other TI intellectual property right relating to any combination, machine, or process in which TI products or services are used. Information published by TI regarding third-party products or services does not constitute a license from TI to use such products or services or a warranty or endorsement thereof. Use of such information may require a license from a third party under the patents or other intellectual property of the third party, or a license from TI under the patents or other intellectual property of TI.

Reproduction of TI information in TI data books or data sheets is permissible only if reproduction is without alteration and is accompanied by all associated warranties, conditions, limitations, and notices. Reproduction of this information with alteration is an unfair and deceptive business practice. TI is not responsible or liable for such altered documentation. Information of third parties may be subject to additional restrictions.

Resale of TI products or services with statements different from or beyond the parameters stated by TI for that product or service voids all express and any implied warranties for the associated TI product or service and is an unfair and deceptive business practice. TI is not responsible or liable for any such statements.

TI products are not authorized for use in safety-critical applications (such as life support) where a failure of the TI product would reasonably be expected to cause severe personal injury or death, unless officers of the parties have executed an agreement specifically governing such use. Buyers represent that they have all necessary expertise in the safety and regulatory ramifications of their applications, and acknowledge and agree that they are solely responsible for all legal, regulatory and safety-related requirements concerning their products and any use of TI products in such safety-critical applications, notwithstanding any applications-related information or support that may be provided by TI. Further, Buyers must fully indemnify TI and its representatives against any damages arising out of the use of TI products in such safety-critical applications.

TI products are neither designed nor intended for use in military/aerospace applications or environments unless the TI products are specifically designated by TI as military-grade or "enhanced plastic." Only products designated by TI as military-grade meet military specifications. Buyers acknowledge and agree that any such use of TI products which TI has not designated as military-grade is solely at the Buyer's risk, and that they are solely responsible for compliance with all legal and regulatory requirements in connection with such use.

TI products are neither designed nor intended for use in automotive applications or environments unless the specific TI products are designated by TI as compliant with ISO/TS 16949 requirements. Buyers acknowledge and agree that, if they use any non-designated products in automotive applications, TI will not be responsible for any failure to meet such requirements.

Following are URLs where you can obtain information on other Texas Instruments products and application solutions:

Products

Amplifiers	amplifier.ti.com
Data Converters	dataconverter.ti.com
DSP	dsp.ti.com
Clocks and Timers	www.ti.com/clocks
Interface	interface.ti.com
Logic	logic.ti.com
Power Mgmt	power.ti.com
Microcontrollers	microcontroller.ti.com
RFID	www.ti-rfid.com
RF/IF and ZigBee® Solutions	www.ti.com/lprf

Applications

Audio	www.ti.com/audio
Automotive	www.ti.com/automotive
Broadband	www.ti.com/broadband
Digital Control	www.ti.com/digitalcontrol
Medical	www.ti.com/medical
Military	www.ti.com/military
Optical Networking	www.ti.com/opticalnetwork
Security	www.ti.com/security
Telephony	www.ti.com/telephony
Video & Imaging	www.ti.com/video
Wireless	www.ti.com/wireless

Mailing Address: Texas Instruments, Post Office Box 655303, Dallas, Texas 75265
Copyright © 2008, Texas Instruments Incorporated

Looking for pricing, stock, or lifecycle information?

Click below to explore more details on WIN SOURCE:

 [View SN74ALS29854DWRE4 on WIN SOURCE](#)

 [Texas Instruments](#) Information

Optimize Your Supply Chain with WIN SOURCE Solutions

-  Global Sourcing Solution
-  Obsolete Management
-  Cost Control Management
-  Shortage Management
-  Alternative Solution
-  Excess Inventory Management