



**THE DATASHEET OF  
LTC6362HMS8#TRPBF**



# Precision, Low Power Rail-to-Rail Input/Output Differential Op Amp/SAR ADC Driver

## FEATURES

- 1mA Supply Current
- Single 2.8V to 5.25V supply
- Fully Differential Input and Output
- 200 $\mu$ V Max Offset Voltage
- 260nA Max Input Bias Current
- Fast Settling: 550ns to 18-Bit, 8V<sub>P-P</sub> Output
- Low Distortion: -116dBc at 1kHz, 8V<sub>P-P</sub>
- Rail-to-Rail Inputs and Outputs
- 3.9nV/ $\sqrt{\text{Hz}}$  Input-Referred Noise
- 180MHz Gain-Bandwidth Product
- 34MHz -3dB Bandwidth
- Low Power Shutdown: 70 $\mu$ A
- 8-Lead MSOP and 3mm  $\times$  3mm 8-Lead DFN Packages

## APPLICATIONS

- 16-Bit and 18-Bit SAR ADC Drivers
- Single-Ended-to-Differential Conversion
- Low Power Pipeline ADC Driver
- Differential Line Drivers
- Battery-Powered Instrumentation

LT, LT, LTC, LTM, Linear Technology and the Linear logo are registered trademarks of Linear Technology Corporation. All other trademarks are the property of their respective owners.

## DESCRIPTION

The LTC<sup>®</sup>6362 is a low power, low noise differential op amp with rail-to-rail input and output swing that has been optimized to drive low power SAR ADCs. The LTC6362 draws only 1mA of supply current in active operation, and features a shutdown mode in which the current consumption is reduced to 70 $\mu$ A.

The amplifier may be configured to convert a single-ended input signal to a differential output signal, and is capable of being operated in an inverting or noninverting configuration.

Low offset voltage, low input bias current, and a stable high impedance configuration make this amplifier suitable for use not only as an ADC driver but also earlier in the signal chain, to convert a precision sensor signal to a balanced (differential) signal for processing in noisy industrial environments.

The LTC6362 is available in an 8-lead MSOP package and also in a compact 3mm  $\times$  3mm 8-pin leadless DFN package, and operates with guaranteed specifications over a -40 $^{\circ}$ C to 125 $^{\circ}$ C temperature range.

## TYPICAL APPLICATION

**DC-Coupled Interface from a Ground-Referenced Single-Ended Input to an LTC2379-18 SAR ADC**

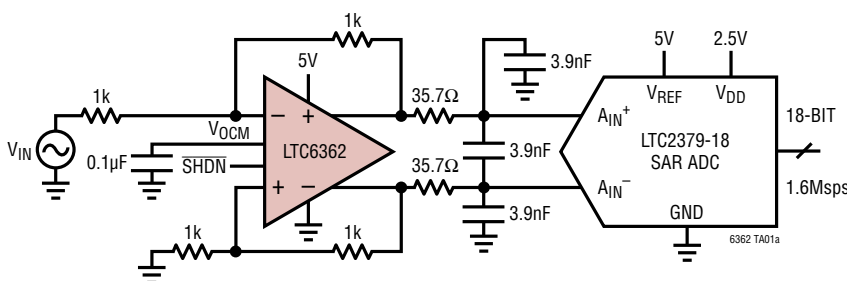

**LTC6362 Driving LTC2379-18**  
 $f_{IN} = 2\text{kHz}$ , -1dBFS, 16384-Point FFT

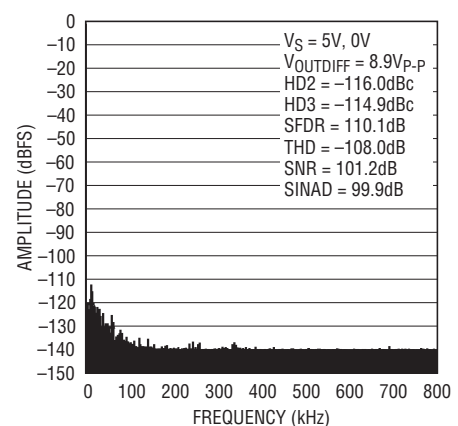

6362 TA01b

# LTC6362

## ABSOLUTE MAXIMUM RATINGS (Note 1)

|   |                   |                                      |                |
|---|-------------------|--------------------------------------|----------------|
| Total Supply Voltage ( $V^+ - V^-$ ) .....                            | 5.5V              | Specified Temperature Range (Note 5) |                |
| Input Current (+IN, -IN, $V_{OCM}$ , $\overline{SHDN}$ ) (Note 2) ... | $\pm 10\text{mA}$ | LTC6362C .....                       | 0°C to 70°C    |
| Output Short-Circuit Duration (Note 3) .....                          | Indefinite        | LTC6362I .....                       | -40°C to 85°C  |
| Operating Temperature Range (Note 4)                                  |                   | LTC6362H .....                       | -40°C to 125°C |
| LTC6362C/LTC6362I .....   | -40°C to 85°C     | Maximum Junction Temperature .....   | 150°C          |
| LTC6362H .....  | -40°C to 125°C    | Storage Temperature Range .....      | -65°C to 150°C |

## PIN CONFIGURATION

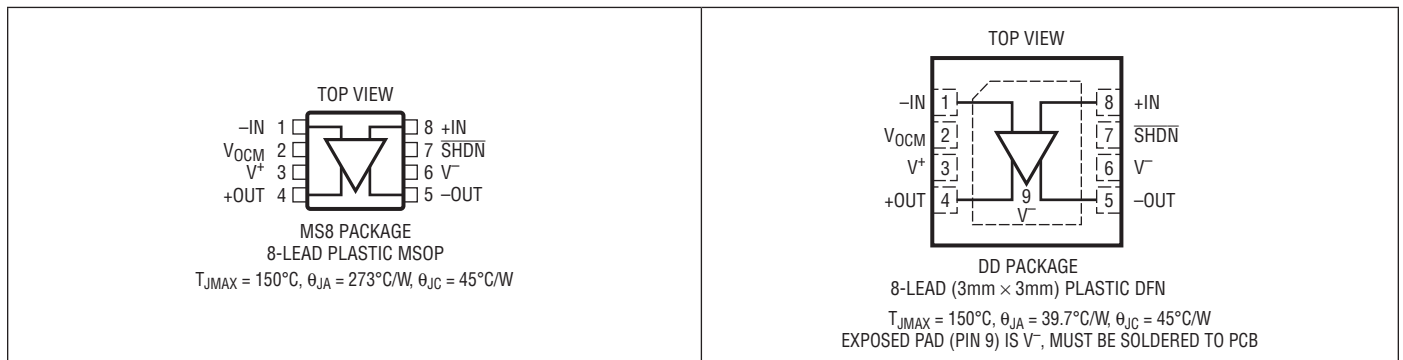

## ORDER INFORMATION

| LEAD FREE FINISH | TAPE AND REEL     | PART MARKING* | PACKAGE DESCRIPTION            | SPECIFIED TEMPERATURE RANGE |
|------------------|-------------------|---------------|--------------------------------|-----------------------------|
| LTC6362CMS8#PBF  | LTC6362CMS8#TRPBF | LTGCN         | 8-Lead Plastic MSOP            | 0°C to 70°C                 |
| LTC6362IMS8#PBF  | LTC6362IMS8#TRPBF | LTGCN         | 8-Lead Plastic MSOP            | -40°C to 85°C               |
| LTC6362HMS8#PBF  | LTC6362HMS8#TRPBF | LTGCN         | 8-Lead Plastic MSOP            | -40°C to 125°C              |
| LTC6362CDD#PBF   | LTC6362CDD#TRPBF  | LGCM          | 8-Lead (3mm × 3mm) Plastic DFN | 0°C to 70°C                 |
| LTC6362IDD#PBF   | LTC6362IDD#TRPBF  | LGCM          | 8-Lead (3mm × 3mm) Plastic DFN | -40°C to 85°C               |
| LTC6362HDD#PBF   | LTC6362HDD#TRPBF  | LGCM          | 8-Lead (3mm × 3mm) Plastic DFN | -40°C to 125°C              |

Consult LTC Marketing for parts specified with wider operating temperature ranges. \*The temperature grade is identified by a label on the shipping container. Consult LTC Marketing for information on non-standard lead based finish parts.

For more information on lead free part marking, go to: <http://www.linear.com/leadfree/>

For more information on tape and reel specifications, go to: <http://www.linear.com/tapeandree/>

**ELECTRICAL CHARACTERISTICS** The ● denotes the specifications which apply over the full operating temperature range, otherwise specifications are at  $T_A = 25^\circ\text{C}$ .  $V^+ = 5\text{V}$ ,  $V^- = 0\text{V}$ ,  $V_{\text{CM}} = V_{\text{OCM}} = V_{\text{ICM}} = 2.5\text{V}$ ,  $V_{\text{SHDN}} = \text{open}$ .  $V_S$  is defined as  $(V^+ - V^-)$ .  $V_{\text{OUTCM}}$  is defined as  $(V_{\text{+OUT}} + V_{\text{-OUT}})/2$ .  $V_{\text{ICM}}$  is defined as  $(V_{\text{+IN}} + V_{\text{-IN}})/2$ .  $V_{\text{OUTDIFF}}$  is defined as  $(V_{\text{+OUT}} - V_{\text{-OUT}})$ .

| SYMBOL                                       | PARAMETER  | CONDITIONS   | MIN | TYP       | MAX       | UNITS                        |
|--|--|--|-----|-----------|-----------|------------------------------|
| $V_{\text{OSDIFF}}$ (Note 6)                 | Differential Offset Voltage (Input Referred)   | $V_S = 3\text{V}$<br>$V_{\text{ICM}} = 1.5\text{V}$    | ●   | 50        | 200       | $\mu\text{V}$                |
|  |  | $V_{\text{ICM}} = 2.75\text{V}$                        | ●   | 65        | 350       | $\mu\text{V}$                |
|  |  | $V_S = 5\text{V}$<br>$V_{\text{ICM}} = 2.5\text{V}$    | ●   | 50        | 200       | $\mu\text{V}$                |
|  |  | $V_{\text{ICM}} = 4.5\text{V}$                         | ●   | 75        | 350       | $\mu\text{V}$                |
| $\Delta V_{\text{OSDIFF}}/\Delta T$ (Note 7) | Differential Offset Voltage Drift (Input Referred)   | $V_S = 3\text{V}$                                      | ●   | 0.9       | 2.5       | $\mu\text{V}/^\circ\text{C}$ |
|  |  | $V_S = 5\text{V}$                                      | ●   | 0.9       | 2.5       | $\mu\text{V}/^\circ\text{C}$ |
| $I_B$ (Note 8)                               | Input Bias Current   | $V_S = 3\text{V}$<br>$V_{\text{ICM}} = 1.5\text{V}$    | ●   | $\pm 100$ | $\pm 350$ | nA                           |
|  |  | $V_{\text{ICM}} = 2.5\text{V}$                         | ●   | $\pm 75$  | $\pm 500$ | nA                           |
|  |  | $V_S = 5\text{V}$<br>$V_{\text{ICM}} = 2.5\text{V}$    | ●   | $\pm 75$  | $\pm 260$ | nA                           |
|  |  | $V_{\text{ICM}} = 4.5\text{V}$                         | ●   | $\pm 75$  | $\pm 460$ | nA                           |
| $\Delta I_B/\Delta T$                        | Input Bias Current Drift   | $V_S = 3\text{V}$                                      | ●   | 1.1       |           | $\text{nA}/^\circ\text{C}$   |
|  |  | $V_S = 5\text{V}$                                      | ●   | 0.9       |           | $\text{nA}/^\circ\text{C}$   |
| $I_{\text{OS}}$ (Note 8)                     | Input Offset Current   | $V_S = 3\text{V}$<br>$V_{\text{ICM}} = 1.5\text{V}$    | ●   | $\pm 75$  | $\pm 325$ | nA                           |
|  |  | $V_{\text{ICM}} = 2.5\text{V}$                         | ●   | $\pm 125$ | $\pm 650$ | nA                           |
|  |  | $V_S = 5\text{V}$<br>$V_{\text{ICM}} = 2.5\text{V}$    | ●   | $\pm 75$  | $\pm 325$ | nA                           |
|  |  | $V_{\text{ICM}} = 4.5\text{V}$                         | ●   | $\pm 125$ | $\pm 500$ | nA                           |
| $R_{\text{IN}}$                              | Input Resistance   | Common Mode  |     | 14        |           | M $\Omega$                   |
|  |  | Differential Mode                                      |     | 32        |           | k $\Omega$                   |
| $C_{\text{IN}}$                              | Input Capacitance  | Differential Mode                                      |     | 2         |           | pF                           |
| $e_n$  | Differential Input Noise Voltage Density   | $f = 100\text{kHz}$ , Not Including $R_I/R_F$ Noise    |     | 3.9       |           | $\text{nV}/\sqrt{\text{Hz}}$ |
| $i_n$  | Input Noise Current Density  | $f = 100\text{kHz}$ , Not Including $R_I/R_F$ Noise    |     | 0.8       |           | $\text{pA}/\sqrt{\text{Hz}}$ |
| $e_{\text{nvocm}}$                           | Common Mode Noise Voltage Density  | $f = 100\text{kHz}$                                    |     | 14.3      |           | $\text{nV}/\sqrt{\text{Hz}}$ |
| $V_{\text{ICMR}}$ (Note 9)                   | Input Common Mode Range  | $V_S = 3\text{V}$                                      | ●   | 0         | 3         | V                            |
|  |  | $V_S = 5\text{V}$                                      | ●   | 0         | 5         | V                            |
| CMRRI (Note 10)                              | Input Common Mode Rejection Ratio (Input Referred) $\Delta V_{\text{ICM}}/\Delta V_{\text{OSDIFF}}$  | $V_S = 3\text{V}$ , $V_{\text{ICM}}$ from 0V to 3V     | ●   | 70        | 95        | dB                           |
|  |  | $V_S = 5\text{V}$ , $V_{\text{ICM}}$ from 0V to 5V     | ●   | 73        | 98        | dB                           |
| CMRRI (Note 10)                              | Output Common Mode Rejection Ratio (Input Referred) $\Delta V_{\text{OCM}}/\Delta V_{\text{OSDIFF}}$ | $V_S = 3\text{V}$ , $V_{\text{OCM}}$ from 0.5V to 2.5V | ●   | 75        | 100       | dB                           |
|  |  | $V_S = 5\text{V}$ , $V_{\text{OCM}}$ from 0.5V to 4.5V | ●   | 55        | 90        | dB                           |
| PSRR (Note 11)                               | Differential Power Supply Rejection ( $\Delta V_S/\Delta V_{\text{OSDIFF}}$ )                        | $V_S = 2.8\text{V}$ to 5.25V                           | ●   | 80        | 105       | dB                           |
| PSRRCM (Note 11)                             | Output Common Mode Power Supply Rejection ( $\Delta V_S/\Delta V_{\text{OSCM}}$ )                    | $V_S = 2.8\text{V}$ to 5.25V                           | ●   | 58        | 72        | dB                           |

**ELECTRICAL CHARACTERISTICS** The ● denotes the specifications which apply over the full operating temperature range, otherwise specifications are at  $T_A = 25^\circ\text{C}$ .  $V^+ = 5\text{V}$ ,  $V^- = 0\text{V}$ ,  $V_{\text{CM}} = V_{\text{OCM}} = V_{\text{ICM}} = 2.5\text{V}$ ,  $V_{\text{SHDN}} = \text{open}$ .  $V_S$  is defined as  $(V^+ - V^-)$ .  $V_{\text{OUTCM}}$  is defined as  $(V_{+\text{OUT}} + V_{-\text{OUT}})/2$ .  $V_{\text{ICM}}$  is defined as  $(V_{+\text{IN}} + V_{-\text{IN}})/2$ .  $V_{\text{OUTDIFF}}$  is defined as  $(V_{+\text{OUT}} - V_{-\text{OUT}})$ .

| SYMBOL                            | PARAMETER  | CONDITIONS  | MIN              | TYP                               | MAX                          | UNITS  |            |
|-----------------------------------|--|---|------------------|-----------------------------------|------------------------------|--|------------|
| GCM                               | Common Mode Gain ( $\Delta V_{\text{OUTCM}}/\Delta V_{\text{OCM}}$ )         | $V_S = 3\text{V}$ , $V_{\text{OCM}}$ from 0.5V to 2.5V<br>$V_S = 5\text{V}$ , $V_{\text{OCM}}$ from 0.5V to 4.5V  | ●<br>●           | 1<br>1                            |                              | V/V<br>V/V   |            |
| $\Delta\text{GCM}$                | Common Mode Gain Error $100 \cdot (\text{GCM} - 1)$                          | $V_S = 3\text{V}$ , $V_{\text{OCM}}$ from 0.5V to 2.5V<br>$V_S = 5\text{V}$ , $V_{\text{OCM}}$ from 0.5V to 4.5V  | ●<br>●           | $\pm 0.07$<br>$\pm 0.07$          | $\pm 0.16$<br>$\pm 0.4$      | %<br>%   |            |
| BAL                               | Output Balance ( $\Delta V_{\text{OUTCM}}/\Delta V_{\text{OUTDIFF}}$ )       | $\Delta V_{\text{OUTDIFF}} = 2\text{V}$<br>Single-Ended Input<br>Differential Input   | ●<br>●           | -57<br>-57                        | -35<br>-35                   | dB<br>dB   |            |
| $A_{\text{VOL}}$                  | Open-Loop Voltage Gain   |   |                  | 95                                |                              | dB   |            |
| $V_{\text{OSCM}}$                 | Common Mode Offset Voltage ( $V_{\text{OUTCM}} - V_{\text{OCM}}$ )           | $V_S = 3\text{V}$<br>$V_S = 5\text{V}$  | ●<br>●           | $\pm 6$<br>$\pm 6$                | $\pm 30$<br>$\pm 30$         | mV<br>mV   |            |
| $\Delta V_{\text{OSCM}}/\Delta T$ | Common Mode Offset Voltage Drift   |   | ●                | 45                                |                              | $\mu\text{V}/^\circ\text{C}$                           |            |
| $V_{\text{OUTCMR}}$ (Note 9)      | Output Signal Common Mode Range (Voltage Range for the $V_{\text{OCM}}$ Pin) | $V_{\text{OCM}}$ Driven Externally, $V_S = 3\text{V}$<br>$V_{\text{OCM}}$ Driven Externally, $V_S = 5\text{V}$  | ●<br>●           | 0.5<br>0.5                        | 2.5<br>4.5                   | V<br>V   |            |
| $V_{\text{OCM}}$                  | Self-Biased Voltage at the $V_{\text{OCM}}$ Pin                              | $V_{\text{OCM}}$ Not Connected, $V_S = 3\text{V}$<br>$V_{\text{OCM}}$ Not Connected, $V_S = 5\text{V}$  | ●<br>●           | 1.475<br>2.475                    | 1.5<br>2.5                   | 1.525<br>2.525   | V<br>V     |
| $R_{\text{INVOCM}}$               | Input Resistance, $V_{\text{OCM}}$ Pin                                       |   | ●                | 110                               | 170                          | 230  | k $\Omega$ |
| $V_{\text{OUT}}$                  | Output Voltage, High, Either Output Pin                                      | $I_L = 0\text{mA}$ , $V_S = 3\text{V}$<br>$I_L = -5\text{mA}$ , $V_S = 3\text{V}$<br>$I_L = 0\text{mA}$ , $V_S = 5\text{V}$<br>$I_L = -5\text{mA}$ , $V_S = 5\text{V}$        | ●<br>●<br>●<br>● | 2.85<br>2.75<br>4.8<br>4.7        | 2.93<br>2.85<br>4.93<br>4.85 | V<br>V<br>V<br>V                                       |            |
|                                   | Output Voltage, Low, Either Output Pin                                       | $I_L = 0\text{mA}$ , $V_S = 3\text{V}$<br>$I_L = 5\text{mA}$ , $V_S = 3\text{V}$<br>$I_L = 0\text{mA}$ , $V_S = 5\text{V}$<br>$I_L = 5\text{mA}$ , $V_S = 5\text{V}$          | ●<br>●<br>●<br>● | 0.05<br>0.13<br>0.05<br>0.13      | 0.15<br>0.3<br>0.2<br>0.4    | V<br>V<br>V<br>V                                       |            |
| $I_{\text{SC}}$                   | Output Short-Circuit Current, Either Output Pin                              | $V_S = 3\text{V}$<br>$V_S = 5\text{V}$  | ●<br>●           | 13<br>15                          | 25<br>35                     | mA<br>mA   |            |
| SR                                | Slew Rate  | Differential $8V_{\text{P-P}}$ Output   |                  | 45                                |                              | V/ $\mu\text{s}$                                       |            |
| GBWP                              | Gain-Bandwidth Product   | $f_{\text{TEST}} = 200\text{kHz}$   | ●                | 145<br>90                         | 180                          | MHz<br>MHz   |            |
| $f_{-3\text{dB}}$                 | -3dB Bandwidth   | $R_I = R_F = 1\text{k}$   |                  | 34                                |                              | MHz  |            |
| HD2/HD3                           | 2nd/3rd Order Harmonic Distortion Single-Ended Input                         | $f = 1\text{kHz}$ , $V_{\text{OUT}} = 8V_{\text{P-P}}$<br>$f = 10\text{kHz}$ , $V_{\text{OUT}} = 8V_{\text{P-P}}$<br>$f = 100\text{kHz}$ , $V_{\text{OUT}} = 8V_{\text{P-P}}$ |                  | -120/-116<br>-106/-103<br>-84/-76 |                              | dBc<br>dBc<br>dBc                                      |            |
| $t_s$                             | Settling Time to a $2V_{\text{P-P}}$ Output Step                             | 0.1%<br>0.01%<br>0.0015% (16-Bit)<br>4ppm (18-Bit)  |                  | 160<br>180<br>230<br>440          |                              | ns<br>ns<br>ns<br>ns                                   |            |
|                                   | Settling Time to a $8V_{\text{P-P}}$ Output Step                             | 0.1%<br>0.01%<br>0.0015% (16-Bit)<br>4ppm (18-Bit)  |                  | 230<br>300<br>460<br>550          |                              | ns<br>ns<br>ns<br>ns                                   |            |
| $V_S$ (Note 12)                   | Supply Voltage Range   |   | ●                | 2.8                               | 5.25                         | V  |            |
| $I_S$                             | Supply Current   | $V_S = 3\text{V}$ , Active<br>$V_S = 3\text{V}$ , Shutdown<br>$V_S = 5\text{V}$ , Active<br>$V_S = 5\text{V}$ , Shutdown  | ●<br>●<br>●<br>● | 0.9<br>55<br>1<br>70              | 0.96<br>1.05<br>1.06<br>1.18 | mA<br>mA<br>mA<br>mA<br>$\mu\text{A}$<br>$\mu\text{A}$ |            |

**ELECTRICAL CHARACTERISTICS** The ● denotes the specifications which apply over the full operating temperature range, otherwise specifications are at  $T_A = 25^\circ\text{C}$ .  $V^+ = 5\text{V}$ ,  $V^- = 0\text{V}$ ,  $V_{\text{CM}} = V_{\text{OCM}} = V_{\text{ICM}} = 2.5\text{V}$ ,  $V_{\text{SHDN}} = \text{open}$ .  $V_S$  is defined as  $(V^+ - V^-)$ .  $V_{\text{OUTCM}}$  is defined as  $(V_{+\text{OUT}} + V_{-\text{OUT}})/2$ .  $V_{\text{ICM}}$  is defined as  $(V_{+\text{IN}} + V_{-\text{IN}})/2$ .  $V_{\text{OUTDIFF}}$  is defined as  $(V_{+\text{OUT}} - V_{-\text{OUT}})$ .

| SYMBOL           | PARAMETER             | CONDITIONS | MIN | TYP | MAX | UNITS         |
|------------------|-----------------------|------------|-----|-----|-----|---------------|
| $V_{\text{IL}}$  | SHDN Input Logic Low  |            | ●   |     | 0.8 | V             |
| $V_{\text{IH}}$  | SHDN Input Logic High |            | ●   | 2   |     | V             |
| $t_{\text{ON}}$  | Turn-On Time          |            |     | 2   |     | $\mu\text{s}$ |
| $t_{\text{OFF}}$ | Turn-Off Time         |            |     | 2   |     | $\mu\text{s}$ |

**Note 1:** Stresses beyond those listed under Absolute Maximum Ratings may cause permanent damage to the device. Exposure to any Absolute Maximum Rating condition for extended periods may affect device reliability and lifetime.

**Note 2:** Input pins (+IN, -IN,  $V_{\text{OCM}}$  and  $\overline{\text{SHDN}}$ ) are protected by steering diodes to either supply. If the inputs should exceed either supply voltage, the input current should be limited to less than 10mA. In addition, the inputs +IN, -IN are protected by a pair of back-to-back diodes. If the differential input voltage exceeds 1.4V, the input current should be limited to less than 10mA.

**Note 3:** A heat sink may be required to keep the junction temperature below the absolute maximum rating when the output is shorted indefinitely.

**Note 4:** The LTC6362C and LTC6362I are guaranteed functional over the operating temperature range of  $-40^\circ\text{C}$  to  $85^\circ\text{C}$ . The LTC6362H is guaranteed functional over the operating temperature range of  $-40^\circ\text{C}$  to  $125^\circ\text{C}$ .

**Note 5:** The LTC6362C is guaranteed to meet specified performance from  $0^\circ\text{C}$  to  $70^\circ\text{C}$ . The LTC6362I is guaranteed to meet specified performance from  $-40^\circ\text{C}$  to  $85^\circ\text{C}$ . The LTC6362C is designed, characterized and expected to meet specified performance from  $-40^\circ\text{C}$  to  $85^\circ\text{C}$ , but is not tested or QA sampled at these temperatures. The LTC6362H is guaranteed to meet specified performance from  $-40^\circ\text{C}$  to  $125^\circ\text{C}$ .

**Note 6:** Differential input referred offset voltage includes offset due to input offset current across 1k source resistance.

**Note 7:** Maximum differential input referred offset voltage drift is determined by a large sampling of typical parts. Drift is not guaranteed by test or QA sampled at this value.

**Note 8:** Input bias current is defined as the maximum of the input currents flowing into either of the input pins (-IN and +IN). Input Offset current is defined as the difference between the input currents ( $I_{\text{OS}} = I_{\text{B}^+} - I_{\text{B}^-}$ ).

**Note 9:** Input common mode range is tested by verifying that at the limits stated in the Electrical Characteristics table, the differential offset ( $V_{\text{OSDIFF}}$ ) and common mode offset ( $V_{\text{OSCM}}$ ) have not deviated by more than  $\pm 1\text{mV}$  and  $\pm 35\text{mV}$  respectively compared to the  $V_{\text{ICM}} = 2.5\text{V}$  (at  $V_S = 5\text{V}$ ) and  $V_{\text{ICM}} = 1.5\text{V}$  (at  $V_S = 3\text{V}$ ) cases.

Output common mode range is tested by verifying that at the limits stated in the Electrical Characteristics table, the common mode offset ( $V_{\text{OSCM}}$ ) has not deviated by more than  $\pm 15\text{mV}$  compared to the  $V_{\text{OCM}} = 2.5\text{V}$  (at  $V_S = 5\text{V}$ ) and  $V_{\text{OCM}} = 1.5\text{V}$  (at  $V_S = 3\text{V}$ ) cases.

**Note 10:** Input CMRR is defined as the ratio of the change in the input common mode voltage at the pins +IN or -IN to the change in differential input referred offset voltage. Output CMRR is defined as the ratio of the change in the voltage at the  $V_{\text{OCM}}$  pin to the change in differential input referred offset voltage. This specification is strongly dependent on feedback ratio matching between the two outputs and their respective inputs and it is difficult to measure actual amplifier performance (see Effects of Resistor Pair Mismatch in the Applications Information section of this data sheet). For a better indicator of actual amplifier performance independent of feedback component matching, refer to the PSRR specification.

**Note 11:** Differential power supply rejection (PSRR) is defined as the ratio of the change in supply voltage to the change in differential input referred offset voltage. Common mode power supply rejection (PSRRCM) is defined as the ratio of the change in supply voltage to the change in the common mode offset voltage.

**Note 12:** Supply voltage range is guaranteed by power supply rejection ratio test.

TYPICAL PERFORMANCE CHARACTERISTICS

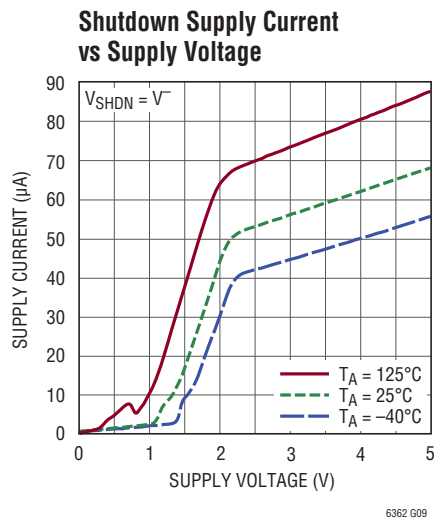
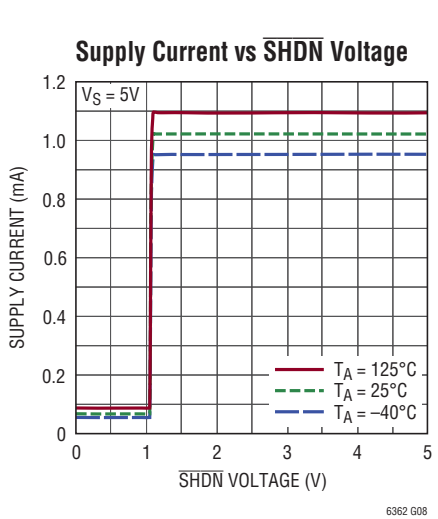
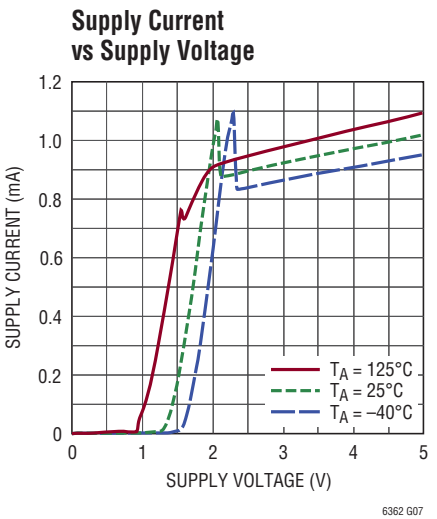
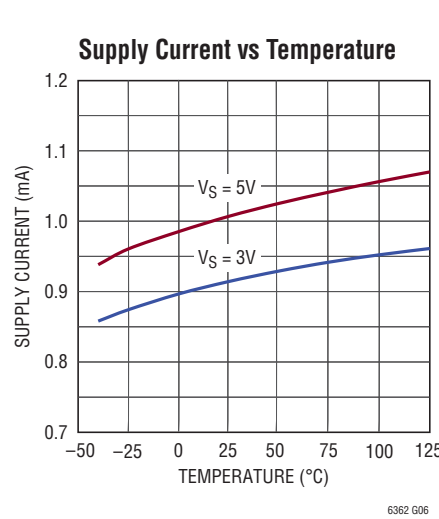
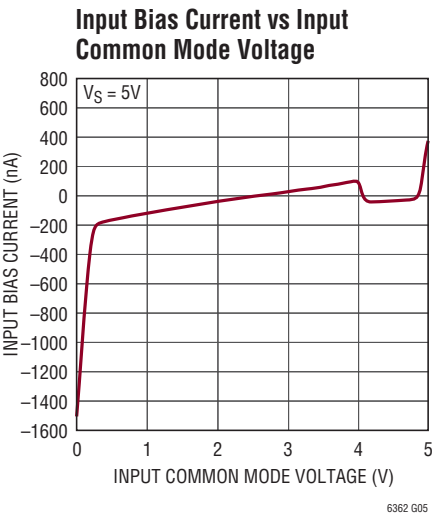
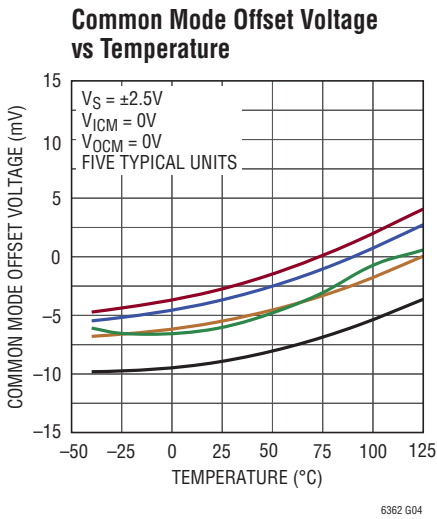
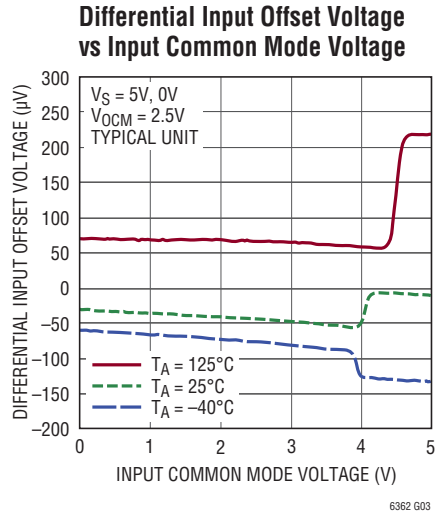
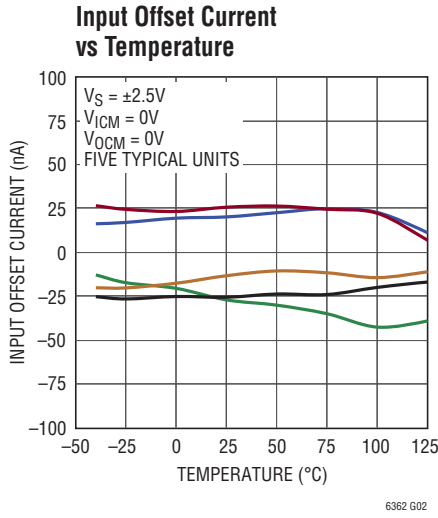
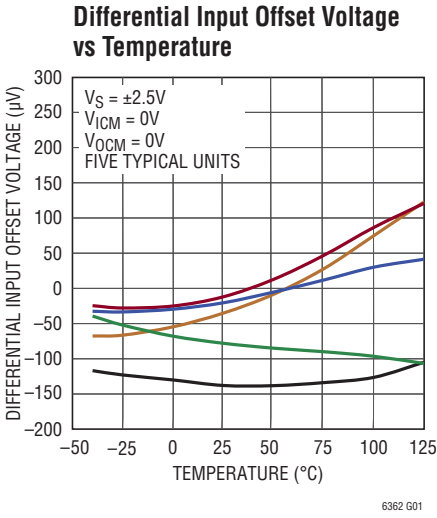

# TYPICAL PERFORMANCE CHARACTERISTICS

**Turn-On and Turn-Off Transient Response**

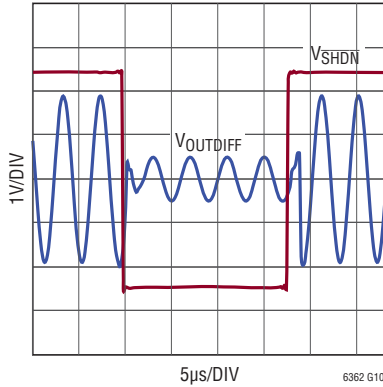

**Input Noise Density vs Frequency**

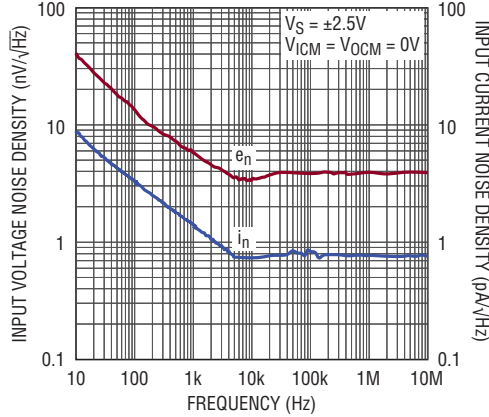

**Differential Output Impedance vs Frequency**

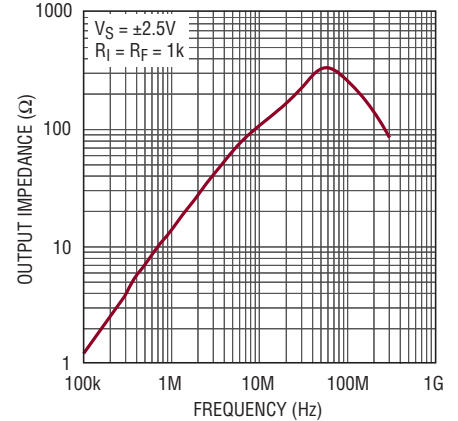

**Common Mode Rejection Ratio vs Frequency**

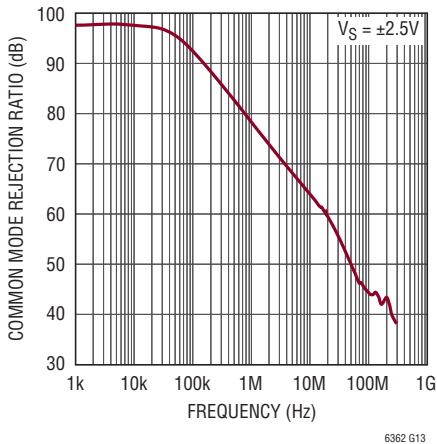

**Differential Power Supply Rejection Ratio vs Frequency**

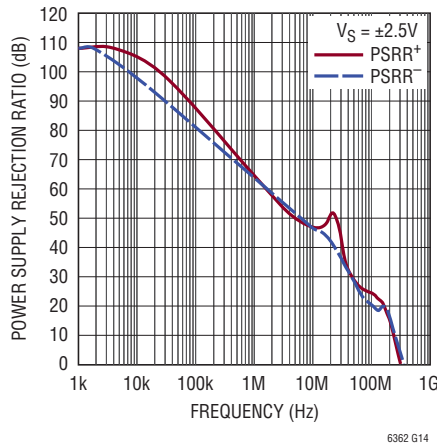

**Slew Rate vs Temperature**

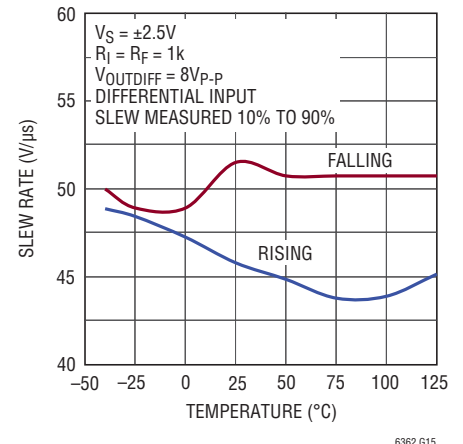

**Small-Signal Step Response**

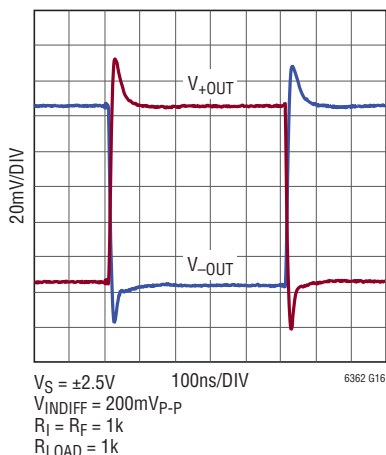

**Large-Signal Step Response**

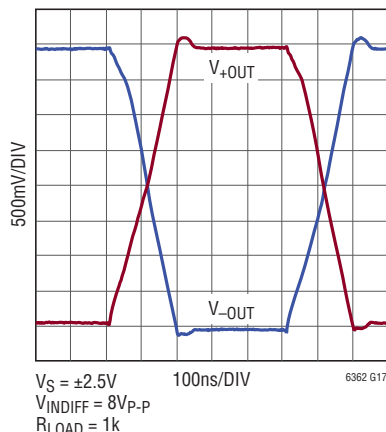

**Overdriven Output Transient Response**

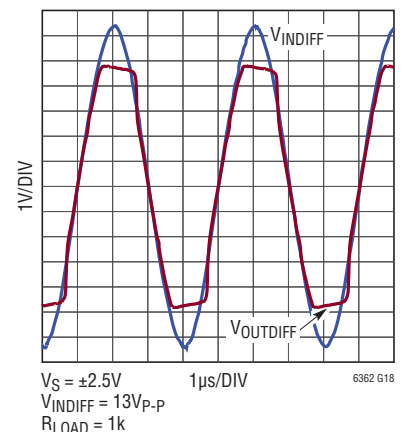

TYPICAL PERFORMANCE CHARACTERISTICS

Frequency Response vs Closed-Loop Gain

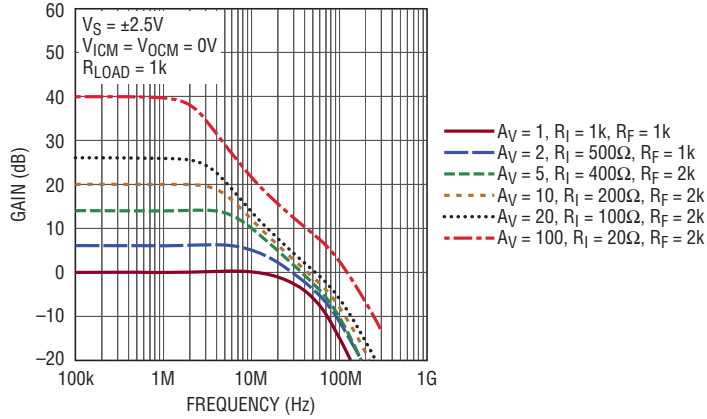

6362 G19

Frequency Peaking vs Load Capacitance

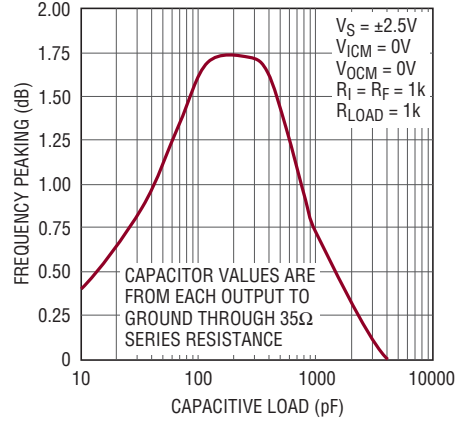

6362 G20

Settling Time vs Output Step

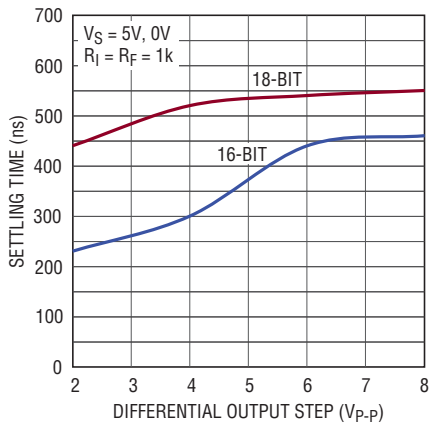

6362 G21

Settling Time to 8VP-P Output Step

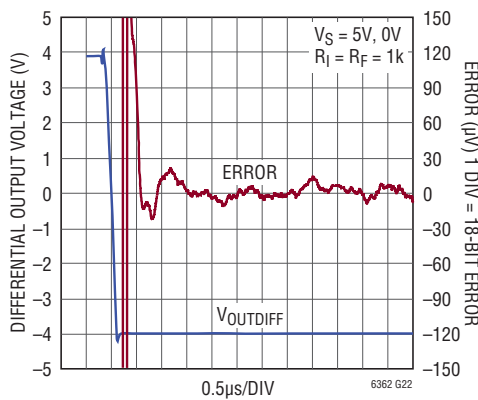

6362 G22

DC Linearity

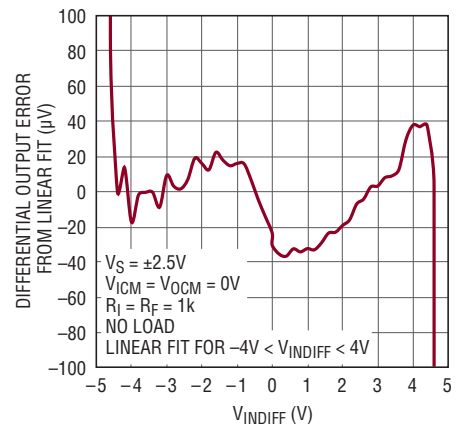

6362 G23

Harmonic Distortion vs Frequency

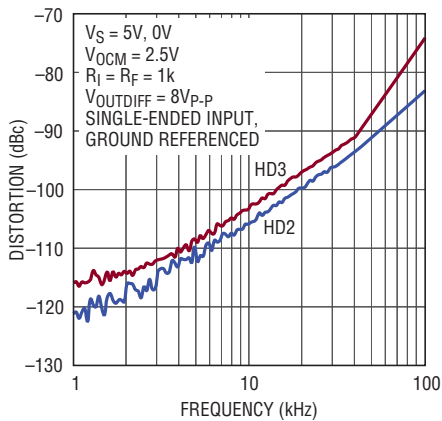

6362 G24

Harmonic Distortion vs Input Common Mode Voltage

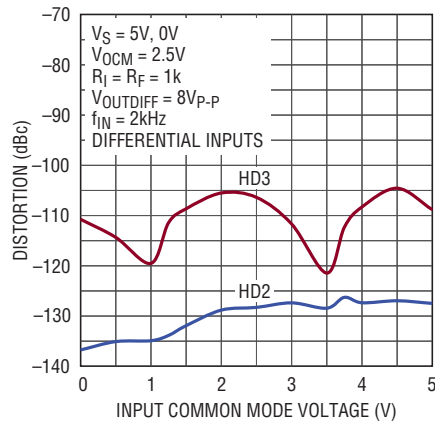

6362 G25

Harmonic Distortion vs Output Amplitude

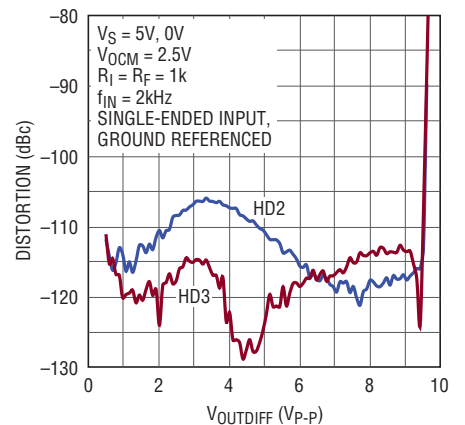

6362 G26

## PIN FUNCTIONS

**-IN (Pin 1):** Inverting Input of Amplifier. Valid input range is from  $V^-$  to  $V^+$ .

**$V_{OCM}$  (Pin 2):** Output Common Mode Reference Voltage. The voltage on this pin sets the output common mode voltage level. If left floating, an internal resistor divider develops a default voltage of 2.5V with a 5V supply.

**$V^+$  (Pin 3):** Positive Power Supply. Operational supply range is 2.8V to 5.25V when  $V^- = 0V$ .

**+OUT (Pin 4):** Positive Output Pin. Output capable of swinging rail-to-rail.

**-OUT (Pin 5):** Negative Output Pin. Output capable of swinging rail-to-rail.

**$V^-$  (Pin 6/Exposed Pad Pin 9):** Negative Power Supply, Typically 0V. Negative supply can be negative as long as  $2.8V \leq (V^+ - V^-) \leq 5.25V$  still holds.

**SHDN (Pin 7):** When SHDN is floating or directly tied to  $V^+$  the LTC6362 is in the normal (active) operating mode. When the SHDN pin is connected to  $V^-$ , the part is disabled and draws approximately 70 $\mu$ A of supply current.

**+IN (Pin 8):** Noninverting Input of Amplifier. Valid input range is from  $V^-$  to  $V^+$ .

## BLOCK DIAGRAM

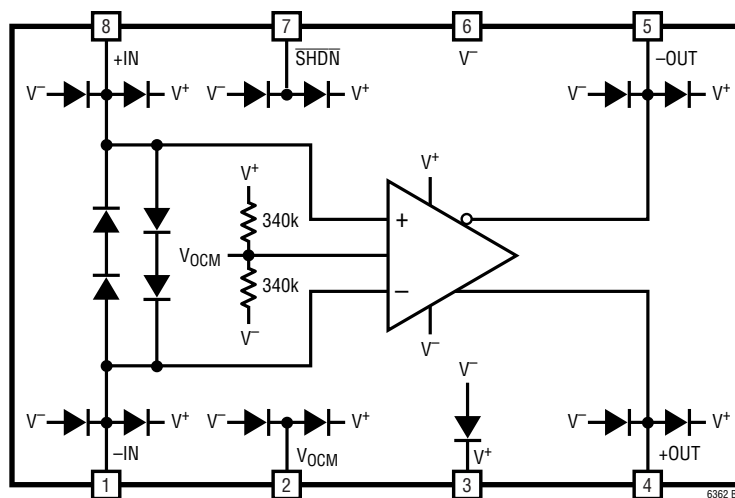

6362 BD

## APPLICATIONS INFORMATION

### Functional Description

The LTC6362 is a low power, low noise, high DC accuracy fully differential operational amplifier/ADC driver. The amplifier is optimized to convert a fully differential or single-ended signal to a low impedance, balanced differential output suitable for driving high performance, low power differential successive approximation register (SAR) ADCs. The balanced differential nature of the amplifier also provides even-order harmonic distortion cancellation, and low susceptibility to common mode noise (like power supply noise).

The outputs of the LTC6362 are capable of swinging rail-to-rail and can source or sink up to 35mA of current. The LTC6362 is optimized for high bandwidth and low power applications. Load capacitances above 10pF to ground or 5pF differentially should be decoupled with 10Ω to 100Ω of series resistance from each output to prevent oscillation or ringing. Feedback should be taken directly from the amplifier output. Higher voltage gain configurations tend to have better capacitive drive capability than lower gain configurations due to lower closed-loop bandwidth.

### Input Pin Protection

The LTC6362 input stage is protected against differential input voltages which exceed 1.4V by two pairs of series diodes connected back-to-back between +IN and -IN. Moreover, all pins have clamping diodes to both power supplies. If any pin is driven to voltages which exceed either supply, the current should be limited to under 10mA to prevent damage to the IC.

### $\overline{\text{SHDN}}$ Pin

The LTC6362 has a  $\overline{\text{SHDN}}$  pin which when driven to within 0.8V above the negative rail, will shut down amplifier operation such that only 70μA is drawn from the supplies. Pull-down circuitry should be capable of sinking at least 4μA to guarantee complete shutdown across all conditions. For normal operation, the  $\overline{\text{SHDN}}$  pin should be left floating or tied to the positive rail.

### General Amplifier Applications

In Figure 1, the gain to  $V_{\text{OUTDIFF}}$  from  $V_{\text{INP}}$  and  $V_{\text{INM}}$  is given by:

$$V_{\text{OUTDIFF}} = V_{+\text{OUT}} - V_{-\text{OUT}} \approx \left( \frac{R_F}{R_I} \right) \cdot (V_{\text{INP}} - V_{\text{INM}})$$

Note from the previous equation, the differential output voltage ( $V_{+\text{OUT}} - V_{-\text{OUT}}$ ) is completely independent of input and output common mode voltages, or the voltage at the common mode pin. This makes the LTC6362 ideally suited for pre-amplification, level shifting and conversion of single-ended signals to differential output signals for driving differential input ADCs.

### Output Common Mode and $V_{\text{OCM}}$ Pin

The output common mode voltage is defined as the average of the two outputs:

$$V_{\text{OUTCM}} = V_{\text{OCM}} = \left( \frac{V_{+\text{OUT}} + V_{-\text{OUT}}}{2} \right)$$

As the equation shows, the output common mode voltage is independent of the input common mode voltage, and is instead determined by the voltage on the  $V_{\text{OCM}}$  pin, by means of an internal common mode feedback loop.

If the  $V_{\text{OCM}}$  pin is left open, an internal resistor divider develops a default voltage of 2.5V with a 5V supply. The  $V_{\text{OCM}}$  pin can be overdriven to another voltage if desired. For example, when driving an ADC, if the ADC makes a reference available for setting the common mode voltage, it can be directly tied to the  $V_{\text{OCM}}$  pin, as long as the ADC is capable of driving the 170k input resistance presented by the  $V_{\text{OCM}}$  pin. The Electrical Characteristics table specifies the valid range that can be applied to the  $V_{\text{OCM}}$  pin ( $V_{\text{OUTCMR}}$ ).

## APPLICATIONS INFORMATION

### Input Common Mode Voltage Range

The LTC6362's input common mode voltage ( $V_{ICM}$ ) is defined as the average of the two input pins,  $V_{+IN}$  and  $V_{-IN}$ . The inputs of the LTC6362 are capable of swinging rail-to-rail and as such the valid range that can be used for  $V_{ICM}$  is  $V^-$  to  $V^+$ . However, due to external resistive divider action of the gain and feedback resistors, the effective range of signals that can be processed is even wider. The input common mode range at the op amp inputs depends on the circuit configuration (gain),  $V_{OCM}$  and  $V_{CM}$  (refer to Figure 1). For fully differential input applications, where  $V_{INP} = -V_{INM}$ , the common mode input is approximately:

$$V_{ICM} = \frac{V_{+IN} + V_{-IN}}{2} \approx V_{OCM} \cdot \frac{R_I}{R_I + R_F} + V_{CM} \cdot \frac{R_F}{R_I + R_F}$$

With single-ended inputs, there is an input signal component to the input common mode voltage. Applying only  $V_{INP}$  (setting  $V_{INM}$  to zero), the input common voltage is approximately:

$$V_{ICM} = \frac{V_{+IN} + V_{-IN}}{2} \\ \approx V_{OCM} \cdot \frac{R_I}{R_I + R_F} + V_{CM} \cdot \frac{R_F}{R_I + R_F} + \frac{V_{INP}}{2} \cdot \frac{R_F}{R_I + R_F}$$

This means that if, for example, the input signal ( $V_{INP}$ ) is a sine, an attenuated version of that sine signal also appears at the op amp inputs.

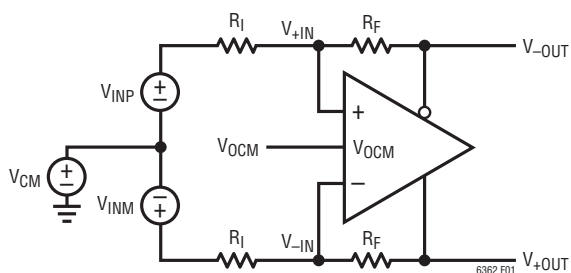

Figure 1. Definitions and Terminology

### Input Bias Current

Input bias current varies according to  $V_{ICM}$ . For common mode voltages ranging from 0.2V above the negative supply to 1.1V below the positive supply, input bias

current follows  $\Delta I_B / \Delta V_{ICM} = 75 \text{ nA/V}$ , with  $I_B$  at  $V_{ICM} = 2.5 \text{ V}$  typically below 75nA on a 5V supply. For common mode voltages ranging from 1.1V below the positive supply to 0.2V below the positive supply, input bias current follows  $\Delta I_B / \Delta V_{ICM} = 25 \text{ nA/V}$ , with  $I_B$  at  $V_{ICM} = 4.5 \text{ V}$  typically below 75nA on a 5V supply. Operating within these ranges allows the amplifier to be used in applications with high source resistances where errors due to voltage drops must be minimized. For applications where  $V_{ICM}$  is within 0.2V of either rail, input bias current may reach values over 1 $\mu\text{A}$ .

### Input Impedance and Loading Effects

The low frequency input impedance looking into the  $V_{INP}$  or  $V_{INM}$  input of Figure 1 depends on how the inputs are driven. For fully differential input sources ( $V_{INP} = -V_{INM}$ ), the input impedance seen at either input is simply:

$$R_{INP} = R_{INM} = R_I$$

For single-ended inputs, because of the signal imbalance at the input, the input impedance actually increases over the balanced differential case. The input impedance looking into either input is:

$$R_{INP} = R_{INM} = \frac{R_I}{1 - \left(\frac{1}{2}\right) \cdot \left(\frac{R_F}{R_I + R_F}\right)}$$

Input signal sources with non-zero output impedances can also cause feedback imbalance between the pair of feedback networks. For the best performance, it is recommended that the input source output impedance be compensated. If input impedance matching is required by the source, a termination resistor  $R_1$  should be chosen (see Figure 2) such that:

$$R_1 = \frac{R_{INM} \cdot R_S}{R_{INM} - R_S}$$

According to Figure 2, the input impedance looking into the differential amp ( $R_{INM}$ ) reflects the single-ended source case, given above. Also,  $R_2$  is chosen as:

$$R_2 = R_1 || R_S = \frac{R_1 \cdot R_S}{R_1 + R_S}$$

APPLICATIONS INFORMATION

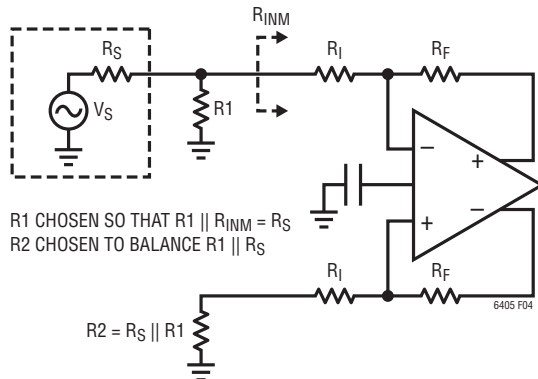

Figure 2. Optimal Compensation for Signal Source Impedance

Effects of Resistor Pair Mismatch

Figure 3 shows a circuit diagram which takes into consideration that real world resistors will not match perfectly. Assuming infinite open-loop gain, the differential output relationship is given by the equation:

$$V_{OUT(DIFF)} = V_{+OUT} - V_{-OUT}$$

$$\approx V_{INDIFF} \cdot \frac{R_F}{R_1} + V_{CM} \cdot \frac{\Delta\beta}{\beta_{AVG}} - V_{OCM} \cdot \frac{\Delta\beta}{\beta_{AVG}}$$

where  $R_F$  is the average of  $R_{F1}$  and  $R_{F2}$ , and  $R_1$  is the average of  $R_{11}$  and  $R_{12}$ .

$\beta_{AVG}$  is defined as the average feedback factor from the outputs to their respective inputs:

$$\beta_{AVG} = \frac{1}{2} \cdot \left( \frac{R_{11}}{R_{11} + R_{F1}} + \frac{R_{12}}{R_{12} + R_{F2}} \right)$$

$\Delta\beta$  is defined as the difference in the feedback factors:

$$\Delta\beta = \frac{R_{12}}{R_{12} + R_{F2}} - \frac{R_{11}}{R_{11} + R_{F1}}$$

Here,  $V_{CM}$  and  $V_{INDIFF}$  are defined as the average and the difference of the two input voltages  $V_{INP}$  and  $V_{INM}$ , respectively:

$$V_{CM} = \frac{V_{INP} + V_{INM}}{2}$$

$$V_{INDIFF} = V_{INP} - V_{INM}$$

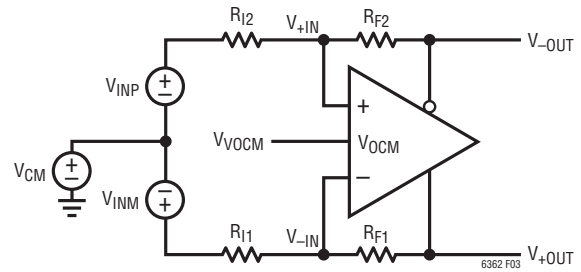

Figure 3. Real-World Application with Feedback Resistor Pair Mismatch

When the feedback ratios mismatch ( $\Delta\beta$ ), common mode to differential conversion occurs. Setting the differential input to zero ( $V_{INDIFF} = 0$ ), the degree of common mode to differential conversion is given by the equation:

$$V_{OUTDIFF} \approx (V_{CM} - V_{OCM}) \cdot \Delta\beta / \beta_{AVG}$$

In general, the degree of feedback pair mismatch is a source of common mode to differential conversion of both signals and noise. Using 0.1% resistors or better will mitigate most problems. A low impedance ground plane should be used as a reference for both the input signal source and the  $V_{OCM}$  pin.

Noise

The LTC6362's differential input referred voltage and current noise densities are  $3.9nV/\sqrt{Hz}$  and  $0.8pA/\sqrt{Hz}$ , respectively. In addition to the noise generated by the amplifier, the surrounding feedback resistors also contribute noise. A simplified noise model is shown in Figure 4. The output noise generated by both the amplifier and the feedback components is given by the equation:

$$e_{no} = \sqrt{\left[ e_{ni} \cdot \left( 1 + \frac{R_F}{R_1} \right) \right]^2 + 2 \cdot (i_n \cdot R_F)^2 + 2 \cdot \left[ e_{nR1} \cdot \frac{R_F}{R_1} \right]^2 + 2 \cdot e_{nRF}^2}$$

For example, if  $R_F = R_1 = 1k$ , the output noise of the circuit  $e_{no} = 12nV/\sqrt{Hz}$ .

If the circuits surrounding the amplifier are well balanced, common mode noise ( $e_{nvocm}$ ) does not appear in the differential output noise equation given above.

## APPLICATIONS INFORMATION

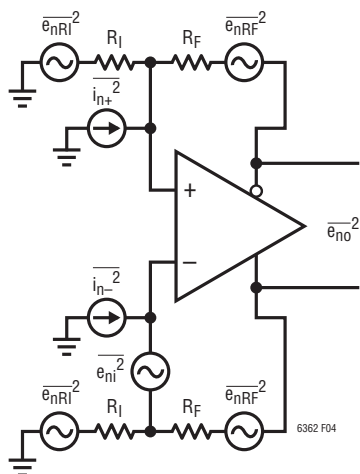

Figure 4. Simplified Noise Model

The LTC6362's input referred voltage noise contributes the equivalent noise of a 920Ω resistor. When the feedback network is comprised of resistors whose values are larger than this, the output noise is resistor noise and amplifier current noise dominant. For feedback networks consisting of resistors with values smaller than 920Ω, the output noise is voltage noise dominant.

Lower resistor values always result in lower noise at the penalty of increased distortion due to increased loading of the feedback network on the output. Higher resistor values will result in higher output noise, but typically improved distortion due to less loading on the output. For this reason, when LTC6362 is configured in a differential gain of 1, using feedback resistors of at least 1k is recommended.

### GBW vs $f_{-3dB}$

Gain-bandwidth product (GBW) and  $-3dB$  frequency ( $f_{-3dB}$ ) have been specified in the Electrical Characteristics table as two different metrics for the speed of the LTC6362. GBW is obtained by measuring the open-loop gain of the amplifier at a specific frequency ( $f_{TEST}$ ), then calculating  $gain \cdot f_{TEST}$ . GBW is a parameter that depends only on the internal design and compensation of the amplifier and is a suitable metric to specify the inherent speed capability of the amplifier.

$f_{-3dB}$ , on the other hand, is a parameter of more practical interest in different applications and is by definition the frequency at which the closed-loop gain is 3dB lower than its low frequency value. The value of  $f_{-3dB}$  depends on the

speed of the amplifier as well as the feedback factor. Since the LTC6362 is designed to be stable in a differential signal gain of 1 (where  $R_I = R_F$  or  $\beta = 1/2$ ), the maximum  $f_{-3dB}$  is obtained and measured in this gain setting, as reported in the Electrical Characteristics table.

In most amplifiers, the open-loop gain response exhibits a conventional single-pole roll-off for most of the frequencies before the unity-gain crossover frequency, and the GBW and unity-gain frequency are close to each other. However, the LTC6362 is intentionally compensated in such a way that its GBW is significantly larger than its  $f_{-3dB}$ . This means that at lower frequencies where the amplifier inputs generally operate, the amplifier's gain and thus the feedback loop gain is larger. This has the important advantage of further linearizing the amplifier and improving distortion at those frequencies.

### Feedback Capacitors

In cases where the LTC6362 is connected such that the combination of parasitic capacitances (device + PCB) at the inverting input forms a pole whose frequency lies within the closed-loop bandwidth of the amplifier, a capacitor ( $C_F$ ) can be added in parallel with the feedback resistor ( $R_F$ ) to cancel the degradation on stability.  $C_F$  should be chosen such that it generates a zero at a frequency close to the frequency of the pole.

In general, a larger value for  $C_F$  reduces the peaking (overshoot) of the amplifier in both frequency and time domains, but also decreases the closed-loop bandwidth ( $f_{-3dB}$ ).

### Board Layout and Bypass Capacitors

For single supply applications, it is recommended that high quality 0.1μF ceramic bypass capacitors be placed directly between the  $V^+$  and the  $V^-$  pin with short connections. The  $V^-$  pins (including the exposed pad in the DD8 package) should be tied directly to a low impedance ground plane with minimal routing. For dual (split) power supplies, it is recommended that additional high quality 0.1μF ceramic capacitors be used to bypass  $V^+$  to ground and  $V^-$  to ground, again with minimal routing. Small geometry (e.g., 0603) surface mount ceramic capacitors have a much higher self-resonant frequency than leaded capacitors, and perform best with LTC6362.

## APPLICATIONS INFORMATION

To prevent degradation in stability response, it is highly recommended that any stray capacitance at the input pins, +IN and -IN, be kept to an absolute minimum by keeping printed circuit connections as short as possible.

At the output, always keep in mind the differential nature of the LTC6362, because it is critical that the load impedances seen by both outputs (stray or intended), be as balanced and symmetric as possible. This will help preserve the balanced operation of the LTC6362 that minimizes the generation of even-order harmonics and maximizes the rejection of common mode signals and noise.

The  $V_{OCM}$  pin should be bypassed to the ground plane with a high quality 0.1 $\mu$ F ceramic capacitor. This will prevent common mode signals and noise on this pin from being inadvertently converted to differential signals and noise by impedance mismatches both externally and internally to the IC.

### Interfacing to ADCs

When driving an ADC, an additional passive filter should be used between the outputs of the LTC6362 and the inputs of the ADC. Depending on the application, a single-pole RC filter will often be sufficient. The sampling process of ADCs creates a charge transient that is caused by the switching in of the ADC sampling capacitor. This momentarily “shorts” the output of the amplifier as charge is transferred between amplifier and sampling capacitor. The amplifier must recover and settle from this load transient before the acquisition period has ended, for a valid representation of the input signal. The RC network between the outputs of the driver and the inputs of the ADC decouples the sampling transient of the ADC (see Figure 5). The capacitance serves to provide the bulk of the charge during the sampling process, while the two resistors at the outputs of the LTC6362 are used to dampen and attenuate any charge injected by the ADC. The RC filter gives the additional benefit of band limiting broadband output noise.

The selection of an appropriate filter depends on the specific ADC, however the following procedure is suggested for choosing filter component values. Begin by selecting an appropriate RC time constant for the input signal. Generally, longer time constants improve SNR at the expense of settling time. Output transient settling to 18-bit accuracy will typically require over twelve RC time constants. To select the resistor value, remember the resistors in the decoupling network should be at least 10 $\Omega$ . Keep in mind that these resistors also serve to decouple the LTC6362 outputs from load capacitance. Too large of a resistor will leave insufficient settling time. Too small of a resistor will not properly dampen the load transient of the sampling process, prolonging the time required for settling. For lowest distortion, choose capacitors with low dielectric absorption (such as a COG multilayer ceramic capacitor). In general, large capacitor values attenuate the fixed nonlinear charge kickback, however very large capacitor values will detrimentally load the driver at the desired input frequency and thus cause driver distortion. Smaller input swings will in general allow for larger filter capacitor values due to decreased loading demands on the driver. This property however may be limited by the particular input amplitude dependence of differential nonlinear charge kickback for the specific ADC used.

In some applications, placing series resistors at the inputs of the ADC may further improve distortion performance. These series resistors function with the ADC sampling capacitor to filter potential ground bounce or other high speed sampling disturbances. Additionally the resistors limit the rise time of residual filter glitches that manage to propagate to the driver outputs. Restricting possible glitch propagation rise time to within the small signal bandwidth of the driver enables less disturbed output settling.

For the specific application of LTC6362 driving the LTC2379-18 SAR ADC in a gain of  $A_V = -1$  configuration, the recommended component values of the RC filter for varying filter bandwidths are provided in Figure 5. These component values are chosen for optimal distortion performance. Broadband output noise will vary with filter bandwidth.

## APPLICATIONS INFORMATION

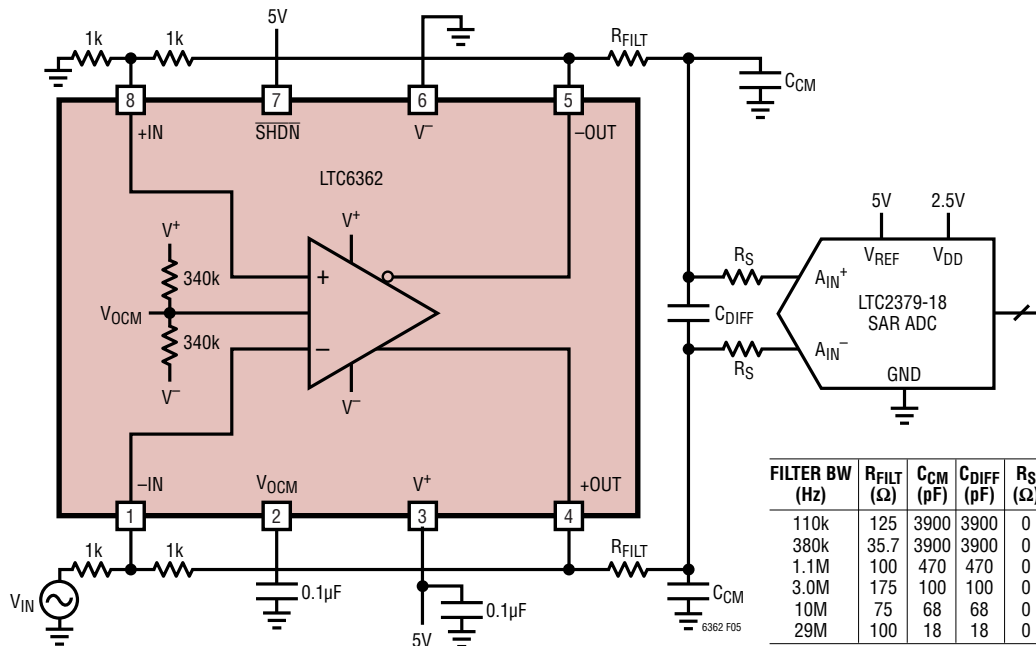
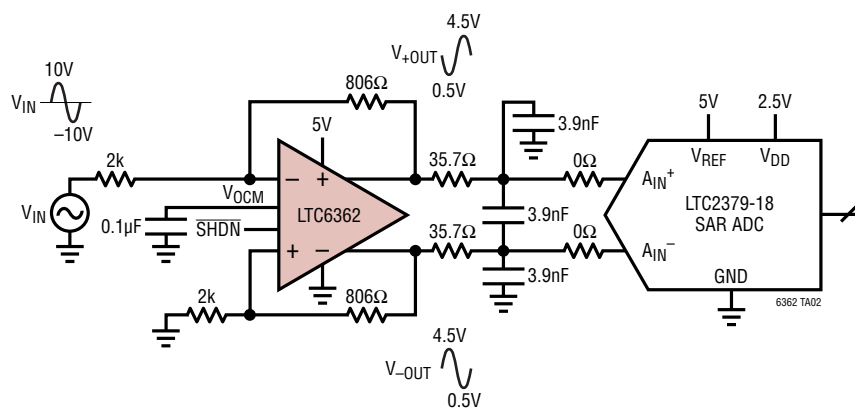

Figure 5. Recommended Interface Solutions for Driving the LTC2379-18 SAR ADC

## TYPICAL APPLICATIONS

Single-Ended-to-Differential Conversion of a 20V<sub>p-p</sub> Ground-Referenced Input with Gain of  $A_V = -0.4$  to Drive an ADC



**TYPICAL APPLICATIONS**

Single-Ended-to-Differential Conversion of a 5V<sub>P-P</sub>, 2.5V Referenced Input with Gain of  $A_V = -1.6$  to Drive an ADC

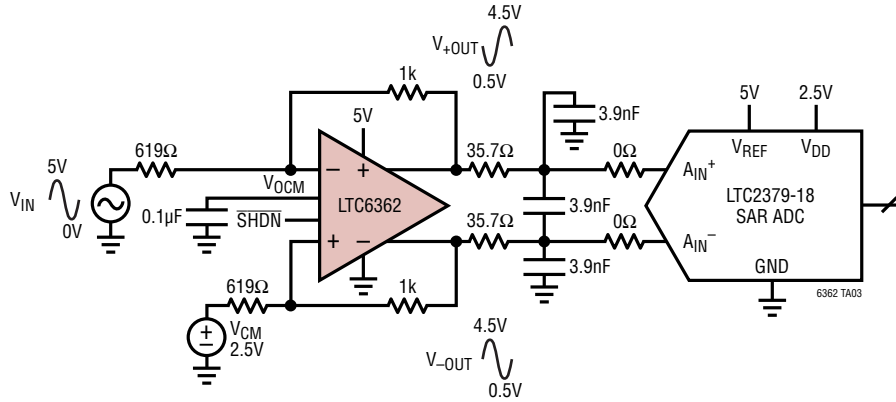

Differentially Driving an ADC with  $\Delta V_{IN} = 8V_{P-P}$  and Gain of  $A_V = 1$

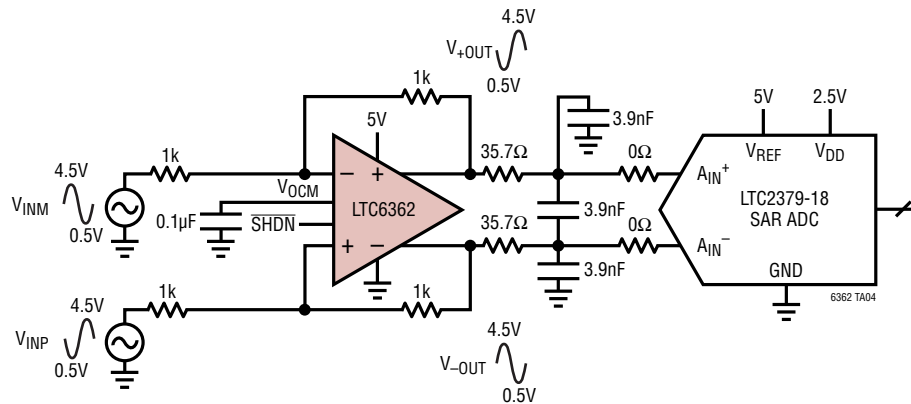

Single-Ended-to-Differential Conversion of a 4V<sub>P-P</sub> Input with Gain of  $A_V = 2$  to Drive an ADC for Applications Where the Importance of High Input Impedance Justifies Some Degradation in Distortion, Noise, and DC Accuracy. Input Is True High Impedance, However Common Mode Noise and Offset Are Present on the Output. Additionally, When the Input Signal Exceeds 2.8V<sub>P-P</sub>, a Step in Input Offset Will Occur That Will Degrade Distortion Performance

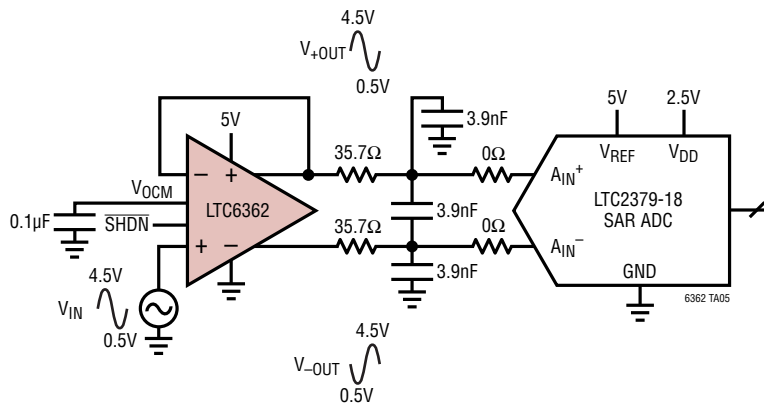

# TYPICAL APPLICATIONS

## Differentially Driving a Pipeline ADC with $A_V = 1$

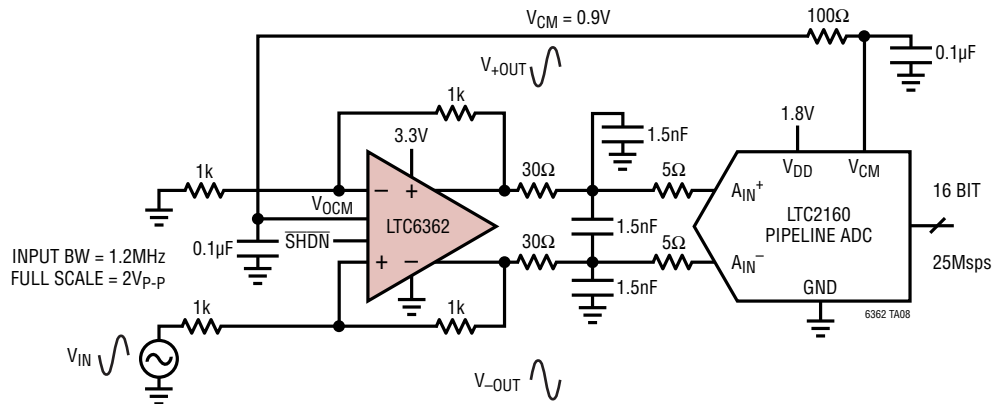

MEASURED PERFORMANCE FOR LTC6362 DRIVING LTC2160:  
 INPUT:  $f_{IN} = 2kHz, -1dBFS$   
 SNR: 77.0dB  
 HD2: -98.9dBc  
 HD3: -102.3dBc  
 THD: -96.3dB

## Differential Line Driver Connected in Gain of $A_V = -1$

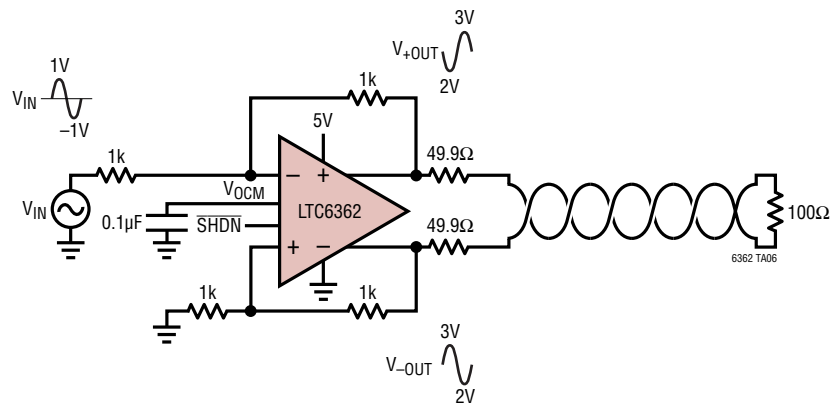

## TYPICAL APPLICATIONS

LTC6362 Used as Lowpass Filter/Driver with 10V<sub>p-p</sub> Singled-Ended Input, Driving a SAR ADC

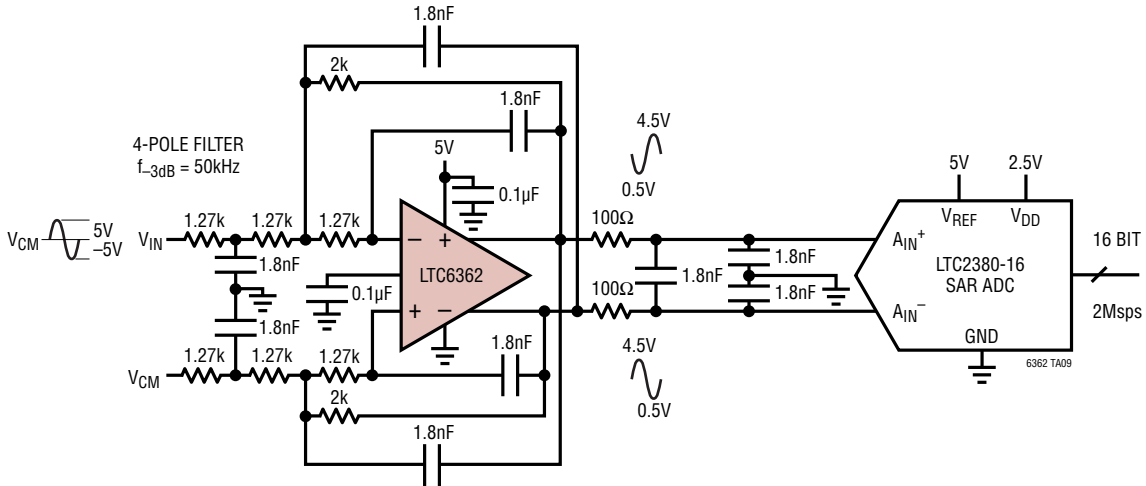

Differential A<sub>v</sub> = 1 Configuration Using an LT<sup>®</sup>5400 Quad-Matched Resistor Network

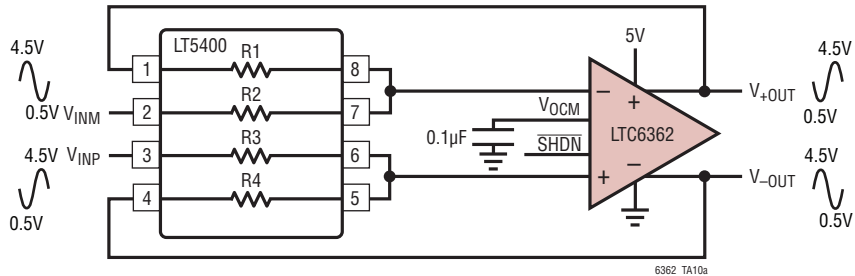

CMRR Comparison Using the LT5400 and 1% 0402 Resistors

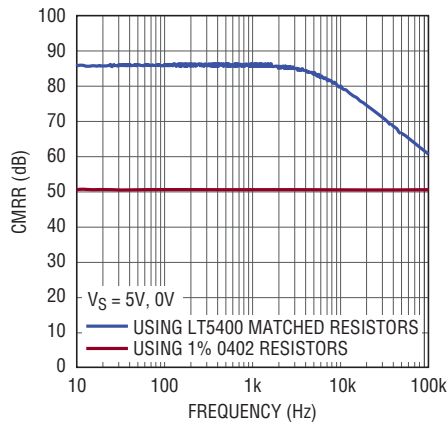

## PACKAGE DESCRIPTION

Please refer to <http://www.linear.com/designtools/packaging/> for the most recent package drawings.

### MS8 Package 8-Lead Plastic MSOP

(Reference LTC DWG # 05-08-1660 Rev F)

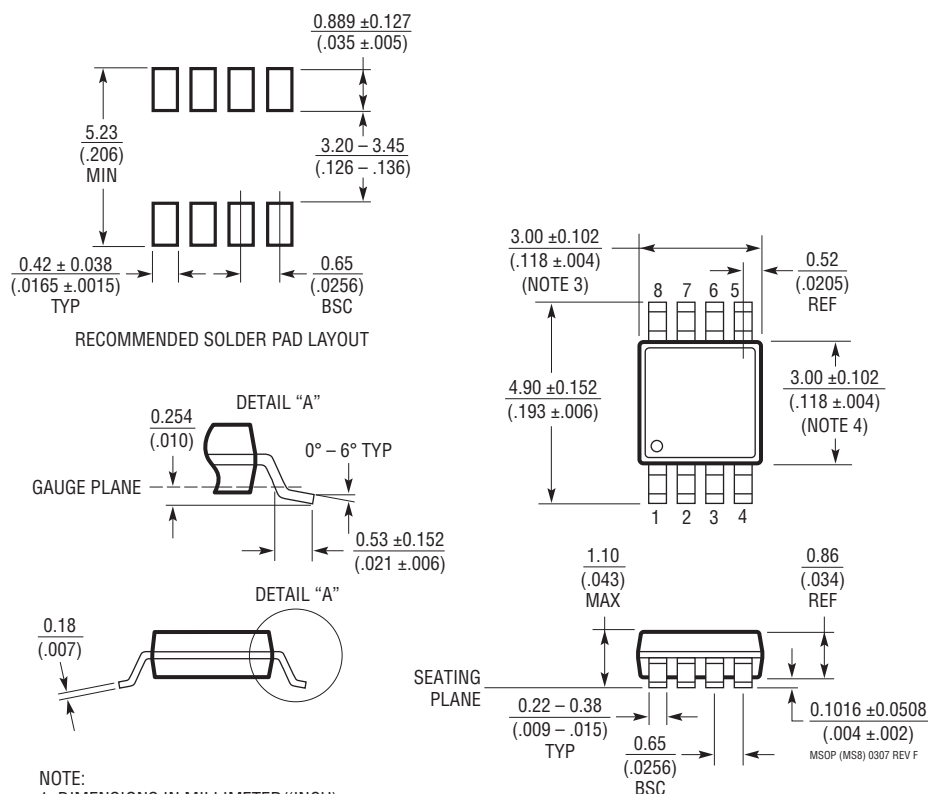

#### NOTE:

1. DIMENSIONS IN MILLIMETER/(INCH)
2. DRAWING NOT TO SCALE
3. DIMENSION DOES NOT INCLUDE MOLD FLASH, PROTRUSIONS OR GATE BURRS.  
MOLD FLASH, PROTRUSIONS OR GATE BURRS SHALL NOT EXCEED  $0.152\text{mm}$  ( $.006^\circ$ ) PER SIDE
4. DIMENSION DOES NOT INCLUDE INTERLEAD FLASH OR PROTRUSIONS.  
INTERLEAD FLASH OR PROTRUSIONS SHALL NOT EXCEED  $0.152\text{mm}$  ( $.006^\circ$ ) PER SIDE
5. LEAD COPLANARITY (BOTTOM OF LEADS AFTER FORMING) SHALL BE  $0.102\text{mm}$  ( $.004^\circ$ ) MAX

# PACKAGE DESCRIPTION

Please refer to <http://www.linear.com/designtools/packaging/> for the most recent package drawings.

**DD Package**  
**8-Lead Plastic DFN (3mm × 3mm)**  
 (Reference LTC DWG # 05-08-1698 Rev C)

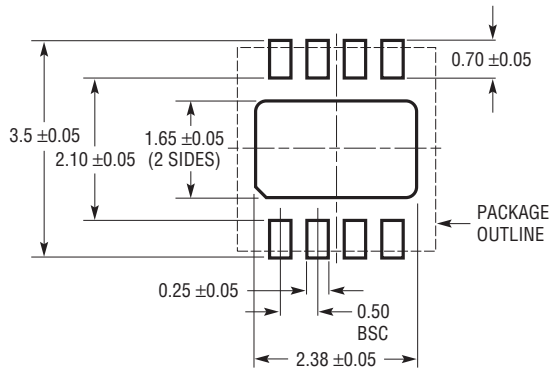

RECOMMENDED SOLDER PAD PITCH AND DIMENSIONS  
 APPLY SOLDER MASK TO AREAS THAT ARE NOT SOLDERED

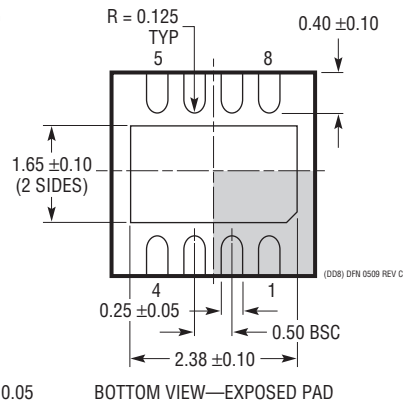
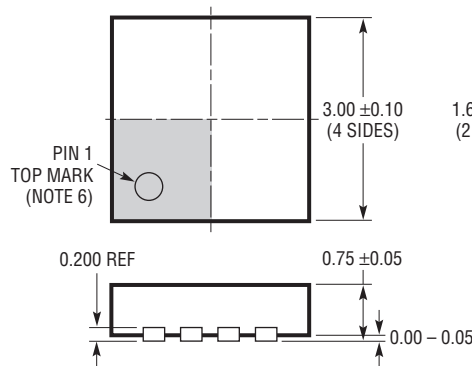

**NOTE:**

1. DRAWING TO BE MADE A JEDEC PACKAGE OUTLINE M0-229 VARIATION OF (WEED-1)
2. DRAWING NOT TO SCALE
3. ALL DIMENSIONS ARE IN MILLIMETERS
4. DIMENSIONS OF EXPOSED PAD ON BOTTOM OF PACKAGE DO NOT INCLUDE MOLD FLASH. MOLD FLASH, IF PRESENT, SHALL NOT EXCEED 0.15mm ON ANY SIDE
5. EXPOSED PAD SHALL BE SOLDER PLATED
6. SHADED AREA IS ONLY A REFERENCE FOR PIN 1 LOCATION ON TOP AND BOTTOM OF PACKAGE

## REVISION HISTORY

| REV | DATE  | DESCRIPTION  | PAGE NUMBER          |
|-----|-------|--|----------------------|
| A   | 05/12 | Added DFN package<br>Added typical spec for $2V_{P-P} t_S$ | 1, 2, 9, 13, 20<br>4 |

## TYPICAL APPLICATION

Single-Ended-to-Differential Conversion of a 10V<sub>P-P</sub> Ground-Referenced Input with Gain of  $A_V = -0.8$  to Drive a 5V Reference SAR ADC

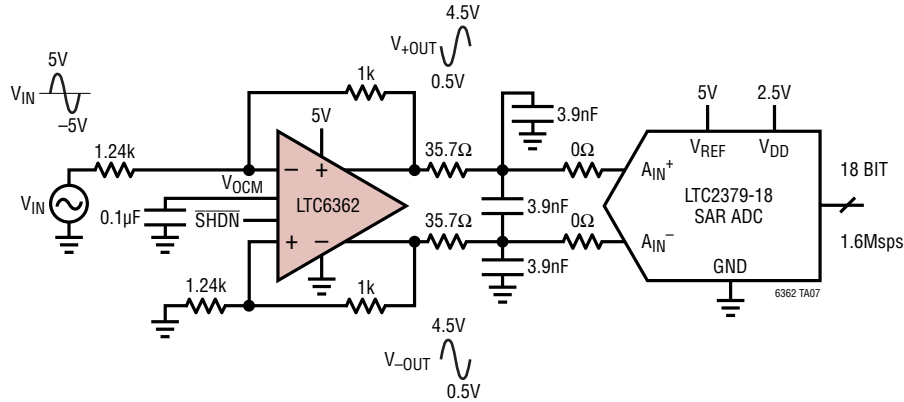

## RELATED PARTS

| PART NUMBER                                    | DESCRIPTION  | COMMENTS  |
|--|--|---|
| <b>Operational Amplifiers</b>                  |  |   |
| LT6350   | Low Noise, Single-Ended to Differential Converter/ADC Driver                     | 4.8mA, -97dBc Distortion at 100kHz, 4V <sub>P-P</sub> Output  |
| LTC6246/LTC6247/<br>LTC6248                    | Single/Dual/Quad 180MHz Rail-to-Rail Low Power Op Amps                           | 1mA/Amplifier, 4.2nV/ $\sqrt{\text{Hz}}$  |
| LTC6360  | 1GHz Very Low Noise Single-Ended SAR ADC Driver with True Zero Output            | 13.6mA, HD2/HD3 = -103dBc/-109dBc at 40kHz, 4V <sub>P-P</sub> Output  |
| LTC1992/LTC1992-X                              | 3MHz to 4MHz Fully Differential Input/Output Amplifiers                          | Internal Feedback Resistors Available (G = 1, 2, 5, 10)   |
| LT1994   | 70MHz Low Noise, Low Distortion Fully Differential Input/Output Amplifier/Driver | 13mA, -94dBc Distortion at 1MHz, 2V <sub>P-P</sub> Output   |
| <b>ADCs</b>                                    |  |   |
| LTC2379-18/LTC2378-18<br>LTC2377-18/LTC2376-18 | 18-Bit, 1.6Msp/1Msp/500ksp/250ksp Serial, Low Power ADC                          | 2.5V Supply, Differential Input, 101.2dB SNR, $\pm 5\text{V}$ Input Range, DGC, Pin Compatible Family in MSOP-16 and 4mm $\times$ 3mm DFN-16 Packages |
| LTC2380-16/LTC2378-16<br>LTC2377-16/LTC2376-16 | 16-Bit, 2Msp/1Msp/500ksp/250ksp Serial, Low Power ADC                            | 2.5V Supply, Differential Input, 96.2dB SNR, $\pm 5\text{V}$ Input Range, DGC, Pin Compatible Family in MSOP-16 and 4mm $\times$ 3mm DFN-16 Packages  |
| LTC2383-16/LTC2382-16/<br>LTC2381-16           | 16-Bit, 1Msp/500ksp/250ksp Serial, Low Power ADC                                 | 2.5V Supply, Differential Input, 92dB SNR, $\pm 2.5\text{V}$ Input Range, Pin Compatible Family in MSOP-16 and 4mm $\times$ 3mm DFN-16 Packages       |
| LTC2393-16/LTC2392-16/<br>LTC2391-16           | 16-Bit, 1Msp/500ksp/250ksp Parallel/Serial ADC                                   | 5V Supply, Differential Input, 94dB SNR, $\pm 4.096\text{V}$ Input Range, Pin Compatible Family in 7mm $\times$ 7mm LQFP-48 and QFN-48 Packages       |
| LTC2355-14/LTC2356-14                          | 14-Bit, 3.5Msp Serial ADC  | 3.3V Supply, 1-Channel, Unipolar/Bipolar, 18mW, MSOP-10 Package   |
| LTC2366  | 12-Bit, 3Msp Serial ADC  | 2.35V to 3.6V Supply 6- and 8-Lead TSOT-23 Packages   |
| LTC2162/LTC2161/<br>LTC2160                    | 16-Bit, 65/40/25Msp Low Power ADC  | 1.8V Supply, Differential Input, 77dB SNR, 2V <sub>P-P</sub> Input Range, Pipeline Converter in 7mm $\times$ 7mm QFN-48 Package                       |

## Looking for pricing, stock, or lifecycle information?

Click below to explore more details on WIN SOURCE:

 [View LTC6362HMS8#TRPBF on WIN SOURCE](#)

 [Analog Devices Inc. Information](#)

## Optimize Your Supply Chain with WIN SOURCE Solutions

-  Global Sourcing Solution
-  Obsolete Management
-  Cost Control Management
-  Shortage Management
-  Alternative Solution
-  Excess Inventory Management