



**THE DATASHEET OF  
SC16C550BIA44,512**



# SC16C550B

5 V, 3.3 V and 2.5 V UART with 16-byte FIFOs

Rev. 6 — 16 December 2014

Product data sheet

## 1. General description

The SC16C550B is a Universal Asynchronous Receiver and Transmitter (UART) used for serial data communications. Its principal function is to convert parallel data into serial data, and vice versa. The UART can handle serial data rates up to 3 Mbit/s.

The SC16C550B is pin compatible with the ST16C550, TL16C550 and PC16C550, and it will power-up to be functionally equivalent to the 16C450. The SC16C550B also provides DMA mode data transfers through FIFO trigger levels and the TXRDY and RXRDY signals (TXRDY and RXRDY are not supported in the HVQFN32 package). On-board status registers provide the user with error indications, operational status, and modem interface control. System interrupts may be tailored to meet user requirements. An internal loopback capability allows on-board diagnostics.

The SC16C550B operates at 5 V, 3.3 V and 2.5 V, and the Industrial temperature range, and is available in plastic HVQFN32, DIP40, PLCC44 and LQFP48 packages.

## 2. Features and benefits

- 5 V, 3.3 V and 2.5 V operation
- Industrial temperature range
- After reset, all registers are identical to the typical 16C450 register set
- Capable of running with all existing generic 16C450 software
- Pin compatibility with the industry-standard ST16C450/550, TL16C450/550, PC16C450/550
- Up to 3 Mbit/s transmit/receive operation at 5 V, 2 Mbit/s at 3.3 V, and 1 Mbit/s at 2.5 V
- 5 V tolerant on input only pins<sup>1</sup>
- 16 byte transmit FIFO
- 16 byte receive FIFO with error flags
- Programmable auto-RTS and auto-CTS
  - ◆ In auto-CTS mode, CTS controls transmitter
  - ◆ In auto-RTS mode, RX FIFO contents and threshold control RTS
- Automatic hardware flow control
- Software selectable baud rate generator
- Four selectable Receive FIFO interrupt trigger levels
- Standard modem interface
- Standard asynchronous error and framing bits (Start, Stop, and Parity Overrun Break)
- Independent receiver clock input
- Transmit, Receive, Line Status, and Data Set interrupts independently controlled

1. For data bus pins D7 to D0, see [Table 24 "Limiting values"](#).



- Fully programmable character formatting:
  - ◆ 5, 6, 7, or 8-bit characters
  - ◆ Even, odd, or no-parity formats
  - ◆ 1, 1½, or 2-stop bit
  - ◆ Baud generation (up to 3 Mbit/s)
- False start-bit detection
- Complete status reporting capabilities
- 3-state output TTL drive capabilities for bidirectional data bus and control bus
- Line break generation and detection
- Internal diagnostic capabilities:
  - ◆ Loopback controls for communications link fault isolation
- Prioritized interrupt system controls
- Modem control functions ( $\overline{\text{CTS}}$ ,  $\overline{\text{RI}}$ ,  $\overline{\text{DCD}}$ ,  $\overline{\text{DSR}}$ ,  $\overline{\text{DTR}}$ ,  $\overline{\text{RTS}}$ )

### 3. Ordering information

**Table 1. Ordering information**

Industrial:  $V_{DD} = 2.5\text{ V}, 3.3\text{ V}$  or  $5\text{ V} \pm 10\%$ ;  $T_{amb} = -40\text{ }^{\circ}\text{C}$  to  $+85\text{ }^{\circ}\text{C}$ .

Type number	Package		Version
	Name	Description	
SC16C550BIA44	PLCC44	plastic leaded chip carrier; 44 leads	SOT187-2
SC16C550BIBS	HVQFN32	plastic thermal enhanced very thin quad flat package; no leads; 32 terminals; body $5 \times 5 \times 0.85\text{ mm}$	SOT617-1
SC16C550BIB48	LQFP48	plastic low profile quad flat package; 48 leads; body $7 \times 7 \times 1.4\text{ mm}$	SOT313-2
SC16C550BIN40	DIP40	plastic dual in-line package; 40 leads (600 mil)	SOT129-1

4. Block diagram

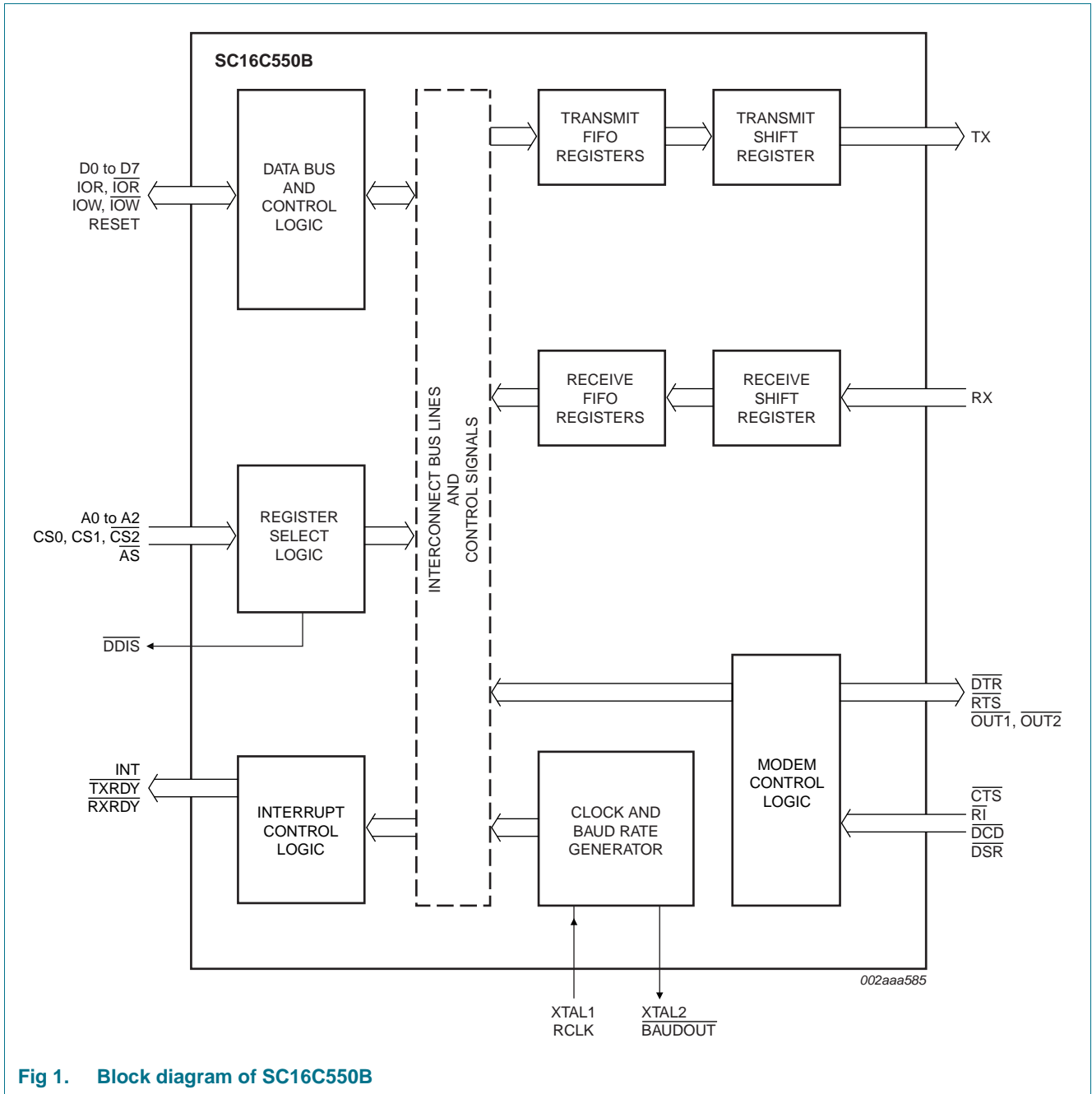

Fig 1. Block diagram of SC16C550B

## 5. Pinning information

### 5.1 Pinning

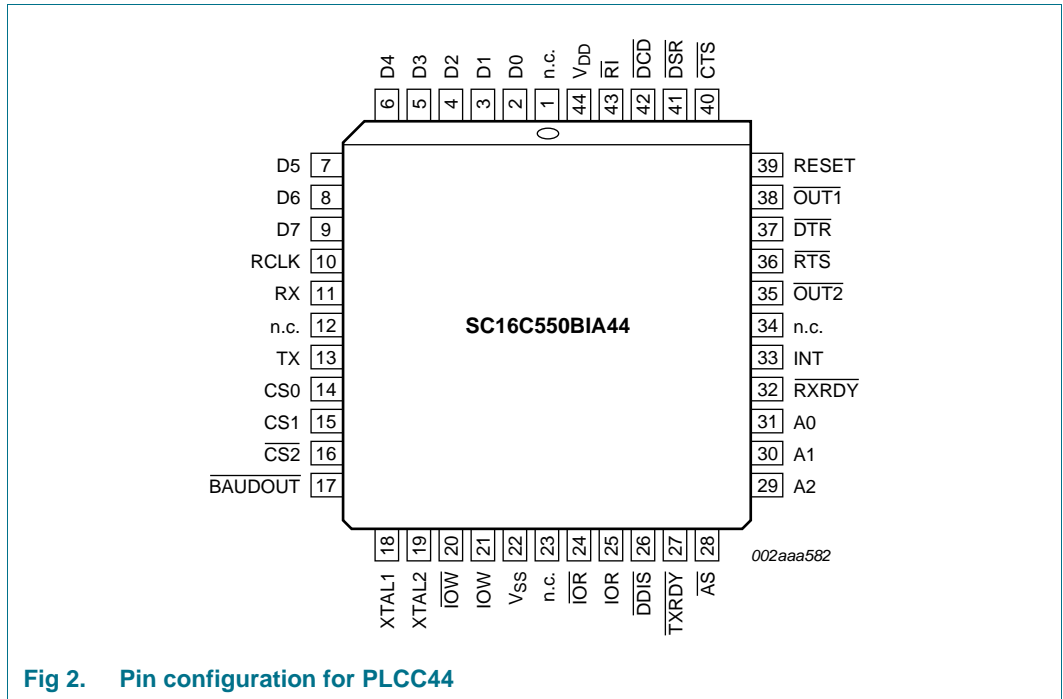

Fig 2. Pin configuration for PLCC44

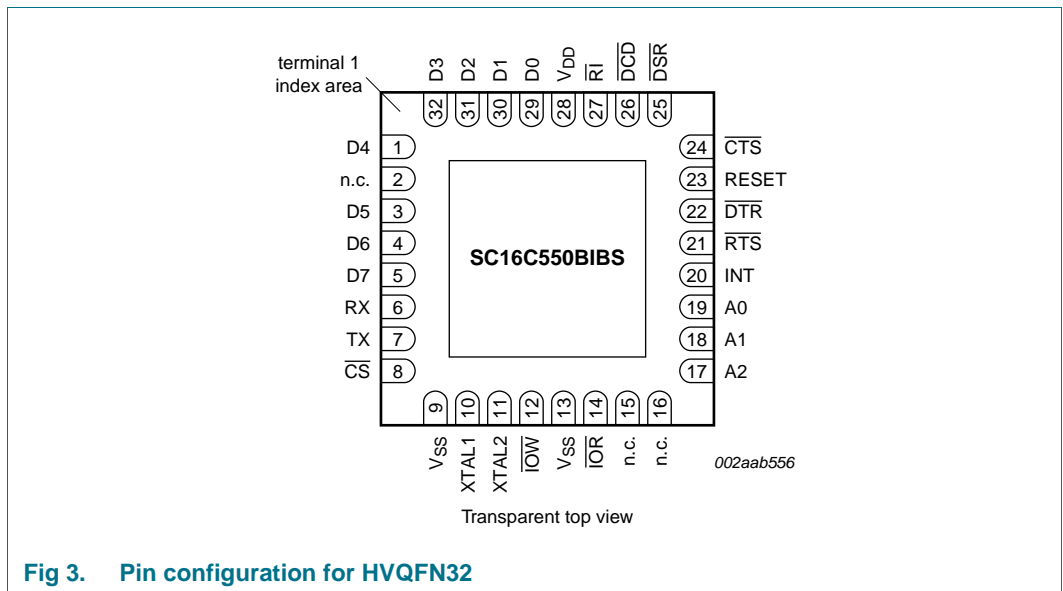
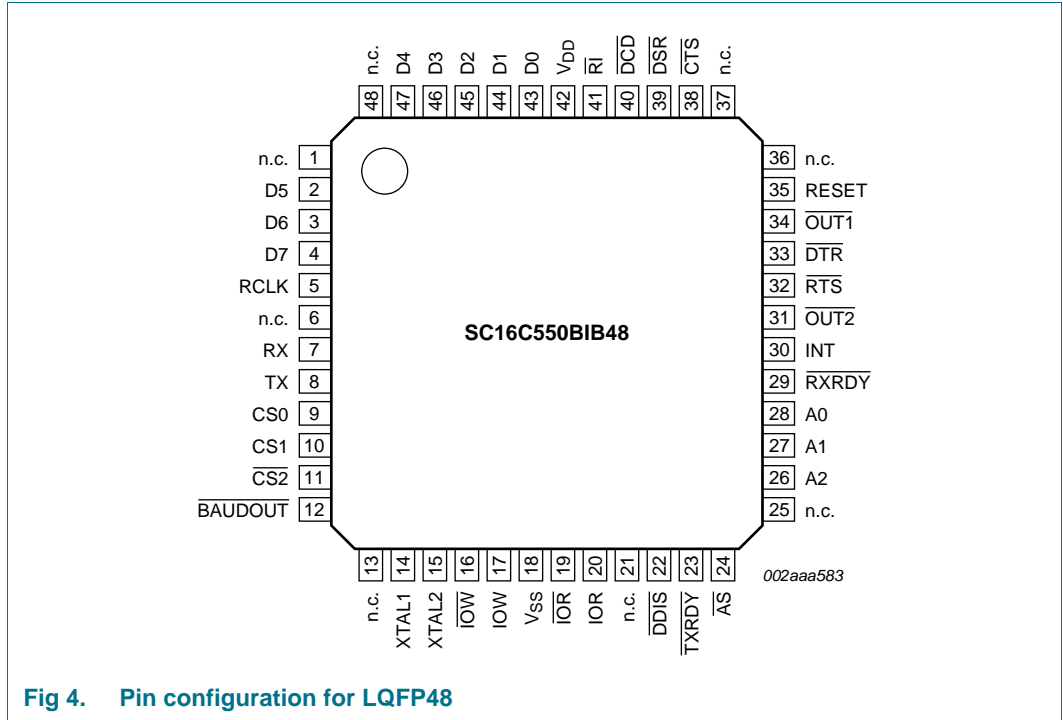
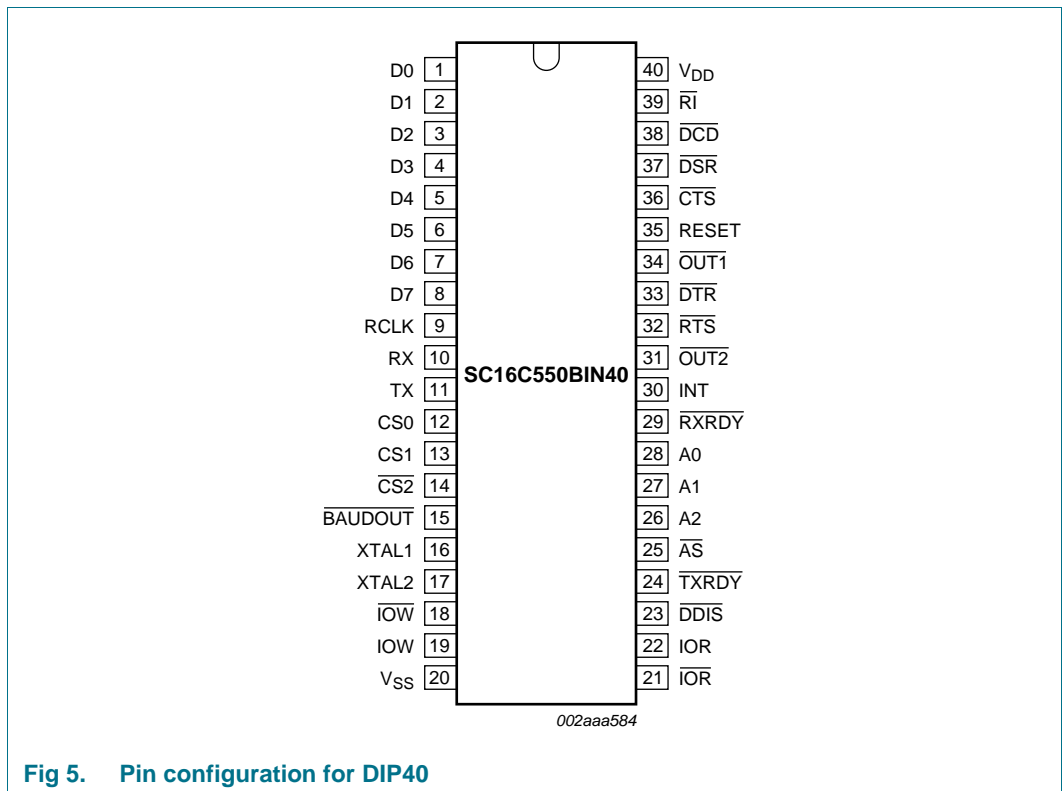

Fig 3. Pin configuration for HVQFN32



**Fig 4. Pin configuration for LQFP48**



**Fig 5. Pin configuration for DIP40**

## 5.2 Pin description

Table 2. Pin description

Symbol	Pin				Type	Description
	PLCC44	LQFP48	DIP40	HVQFN32		
A0	31	28	28	19	I	<b>Register select.</b> A2 to A0 are used during read and write operations to select the UART register to read from or write to. Refer to <a href="#">Table 3</a> for register addresses and refer to $\overline{AS}$ description.
A1	30	27	27	18		
A2	29	26	26	17		
$\overline{AS}$	28	24	25	-	I	<b>Address strobe.</b> When $\overline{AS}$ is active (LOW), A0, A1, and A2 and CS0, CS1, and $\overline{CS2}$ drive the internal select logic directly; when $\overline{AS}$ is HIGH, the register select and chip select signals are held at the logic levels they were in when the LOW-to-HIGH transition of $\overline{AS}$ occurred.
$\overline{BAUDOUT}$	17	12	15	-	O	<b>Baud out.</b> $\overline{BAUDOUT}$ is a 16× clock signal for the transmitter section of the UART. The clock rate is established by the reference oscillator frequency divided by a divisor specified in the baud generator divisor latches. $\overline{BAUDOUT}$ may also be used for the receiver section by tying this output to RCLK. In HVQFN32 package $\overline{BAUDOUT}$ and RCLK are bonded internally.
CS0 <sup>[2]</sup>	14	9	12	-	I	<b>Chip select.</b> When CS0 and CS1 are HIGH and $\overline{CS2}$ is LOW, these three inputs select the UART. When any of these inputs are inactive, the UART remains inactive (refer to $\overline{AS}$ description).
CS1 <sup>[2]</sup>	15	10	13	-		
$\overline{CS2}$ <sup>[2]</sup>	16	11	14	-		
CS <sup>[2]</sup>	-	-	-	8		
$\overline{CTS}$ <sup>[2]</sup>	40	38	36	24	I	<b>Clear to send.</b> $\overline{CTS}$ is a modem status signal. Its condition can be checked by reading bit 4 ( $\overline{CTS}$ ) of the Modem Status Register. Bit 0 ( $\overline{CTS}$ ) of the Modem Status Register indicates that $\overline{CTS}$ has changed states since the last read from the Modem Status Register. If the modem status interrupt is enabled when $\overline{CTS}$ changes levels and the auto- $\overline{CTS}$ mode is not enabled, an interrupt is generated. This pin has no effect on the UART's transmit or receive operation.
D7 to D0	9, 8, 7, 6, 5, 4, 3, 2	4, 3, 2, 47, 46, 45, 44, 43	8, 7, 6, 5, 4, 3, 2, 1	5, 4, 3, 1, 32, 31, 30, 29	I/O	<b>Data bus.</b> Eight data lines with 3-state outputs provide a bidirectional path for data, control and status information between the UART and the CPU.
$\overline{DCD}$ <sup>[2]</sup>	42	40	38	26	I	<b>Data carrier detect.</b> $\overline{DCD}$ is a modem status signal. Its condition can be checked by reading bit 7 (DCD) of the Modem Status Register. Bit 3 ( $\overline{DCD}$ ) of the Modem Status Register indicates that $\overline{DCD}$ has changed states since the last read from the Modem Status Register. If the modem status interrupt is enabled when $\overline{DCD}$ changes levels, an interrupt is generated.
$\overline{DDIS}$	26	22	23	-	O	<b>Driver disable.</b> $\overline{DDIS}$ is active (LOW) when the CPU is reading data. When inactive (HIGH), $\overline{DDIS}$ can disable an external transceiver.

Table 2. Pin description ...continued

Symbol	Pin				Type	Description
	PLCC44	LQFP48	DIP40	HVQFN32		
$\overline{\text{DSR}}$ <sup>[2]</sup>	41	39	37	25	I	<b>Data set ready.</b> $\overline{\text{DSR}}$ is a modem status signal. Its condition can be checked by reading bit 5 ( $\overline{\text{DSR}}$ ) of the Modem Status Register. Bit 1 ( $\overline{\text{DSR}}$ ) of the Modem Status Register indicates $\overline{\text{DSR}}$ has changed levels since the last read from the Modem Status Register. If the modem status interrupt is enabled when $\overline{\text{DSR}}$ changes levels, an interrupt is generated.
$\overline{\text{DTR}}$	37	33	33	22	O	<b>Data terminal ready.</b> When active (LOW), $\overline{\text{DTR}}$ informs a modem or data set that the UART is ready to establish communication. $\overline{\text{DTR}}$ is placed in the active level by setting the $\overline{\text{DTR}}$ bit of the Modem Control Register. $\overline{\text{DTR}}$ is placed in the inactive level either as a result of a Master Reset, during loopback mode operation, or clearing the $\overline{\text{DTR}}$ bit.
INT	33	30	30	20	O	<b>Interrupt.</b> When active (HIGH), INT informs the CPU that the UART has an interrupt to be serviced. Four conditions that cause an interrupt to be issued are: a receiver error, received data that is available or timed out (FIFO mode only), an empty Transmitter Holding Register or an enabled modem status interrupt. INT is reset (deactivated) either when the interrupt is serviced or as a result of a Master Reset.
n.c.	1, 12, 23, 34	1, 6, 13, 21, 25, 36, 37, 48	-	2, 15, 16	-	not connected
$\overline{\text{OUT1}}$	38	34	34	-	O	<b>Outputs 1 and 2.</b> These are user-designated output terminals that are set to the active (LOW) level by setting respective Modem Control Register (MCR) bits ( $\overline{\text{OUT1}}$ and $\overline{\text{OUT2}}$ ). $\overline{\text{OUT1}}$ and $\overline{\text{OUT2}}$ are set to inactive the (HIGH) level as a result of Master Reset, during loopback mode operations, or by clearing bit 2 ( $\overline{\text{OUT1}}$ ) or bit 3 ( $\overline{\text{OUT2}}$ ) of the MCR.
$\overline{\text{OUT2}}$	35	31	31	-		
RCLK	10	5	9	-	I	<b>Receiver clock.</b> RCLK is the 16× baud rate clock for the receiver section of the UART. In the HVQFN32 package, $\overline{\text{BAUDOUT}}$ and RCLK are bonded internally.
IOR	25	20	22	-	I	<b>Read inputs.</b> When either $\overline{\text{IOR}}$ or IOR is active (LOW or HIGH, respectively) while the UART is selected, the CPU is allowed to read status information or data from a selected UART register. Only one of these inputs is required for the transfer of data during a read operation; the other input should be tied to its inactive level (that is, IOR tied LOW or $\overline{\text{IOR}}$ tied HIGH).
$\overline{\text{IOR}}$ <sup>[2]</sup>	24	19	21	14		
RESET	39	35	35	23	I	<b>Master reset.</b> When active (HIGH), RESET clears most UART registers and sets the levels of various output signals.

Table 2. Pin description ...continued

Symbol	Pin				Type	Description
	PLCC44	LQFP48	DIP40	HVQFN32		
$\overline{\text{RI}}$ <sup>[2]</sup>	43	41	39	27	I	<b>Ring indicator.</b> $\overline{\text{RI}}$ is a modem status signal. Its condition can be checked by reading bit 6 (RI) of the Modem Status Register. Bit 2 ( $\Delta\overline{\text{RI}}$ ) of the Modem Status Register indicates that $\overline{\text{RI}}$ has changed from a LOW to a HIGH level since the last read from the Modem Status Register. If the modem status interrupt is enabled when this transition occurs, an interrupt is generated.
$\overline{\text{RTS}}$	36	32	32	21	O	<b>Request to send.</b> When active, $\overline{\text{RTS}}$ informs the modem or data set that the UART is ready to receive data. $\overline{\text{RTS}}$ is set to the active level by setting the RTS Modem Control Register bit and is set to the inactive (HIGH) level either as a result of a Master Reset or during loopback mode operations or by clearing bit 1 (RTS) of the MCR. This pin has no effect on the UART's transmit or receive operation.
$\overline{\text{RXRDY}}$	32	29	29	-	O	<b>Receiver ready.</b> Receiver Direct Memory Access (DMA) signaling is available with $\overline{\text{RXRDY}}$ . When operating in the FIFO mode, one of two types of DMA signaling can be selected using the FIFO Control Register bit 3 (FCR[3]). When operating in the 16C450 mode, only DMA mode 0 is allowed. Mode 0 supports single-transfer DMA in which a transfer is made between CPU bus cycles. Mode 1 supports multi-transfer DMA in which multiple transfers are made continuously until the receiver FIFO has been emptied. In DMA mode 0 (FCR[0] = 0 or FCR[0] = 1, FCR[3] = 0), when there is at least one character in the receiver FIFO or Receiver Holding Register, $\overline{\text{RXRDY}}$ is active (LOW). When $\overline{\text{RXRDY}}$ has been active but there are no characters in the FIFO or holding register, $\overline{\text{RXRDY}}$ goes inactive (HIGH). In DMA mode 1 (FCR[0] = 1, FCR[3] = 1), when the trigger level or the time-out has been reached, $\overline{\text{RXRDY}}$ goes active (LOW); when it has been active but there are no more characters in the FIFO or holding register, it goes inactive (HIGH). This function does not exist in the HVQFN32 package.
RX	11	7	10	6	I	<b>Serial data input.</b> RX is serial data input from a connected communications device.
TX	13	8	11	7	O	<b>Serial data output.</b> TX is composite serial data output to a connected communication device. TX is set to the marking (HIGH) level as a result of Master Reset.
$\overline{\text{TXRDY}}$	27	23	24	-	O	<b>Transmitter ready.</b> Transmitter DMA signaling is available with $\overline{\text{TXRDY}}$ . When operating in the FIFO mode, one of two types of DMA signaling can be selected using FCR[3]. When operating in the 16C450 mode, only DMA mode 0 is allowed. Mode 0 supports single-transfer DMA in which a transfer is made between CPU bus cycles. Mode 1 supports multi-transfer DMA in which multiple transfers are made continuously until the transmit FIFO has been filled. This function does not exist in the HVQFN32 package.
$V_{\text{DD}}$	44	42	40	28	power	<b>2.5 V, 3.3 V or 5 V supply voltage.</b>
$V_{\text{SS}}$	22	18	20	9, 13 <sup>[1]</sup>	power	<b>Ground voltage.</b>

Table 2. Pin description ...continued

Symbol	Pin				Type	Description
	PLCC44	LQFP48	DIP40	HVQFN32		
IOW	21	17	19	-	I	<b>Write inputs.</b> When either $\overline{\text{IOW}}$ or IOW is active (LOW or HIGH, respectively) and while the UART is selected, the CPU is allowed to write control words or data into a selected UART register. Only one of these inputs is required to transfer data during a write operation; the other input should be tied to its inactive level (that is, IOW tied LOW or $\overline{\text{IOW}}$ tied HIGH).
$\overline{\text{IOW}}$ <sup>[2]</sup>	20	16	18	12		
XTAL1	18	14	16	10	I	<b>Crystal connection or External clock input.</b>
XTAL2 <sup>[3]</sup>	19	15	17	11	O	

[1] HVQFN32 package die supply ground is connected to both the  $V_{SS}$  pin and the exposed center pad. The  $V_{SS}$  pin must be connected to supply ground for proper device operation. For enhanced thermal, electrical, and board-level performance, the exposed pad needs to be soldered to the board using a corresponding thermal pad on the board, and for proper heat conduction through the board thermal vias need to be incorporated in the Printed-Circuit Board (PCB) in the thermal pad region.

[2] This pin has a pull-up resistor.

[3] In Sleep mode, XTAL2 is left floating.

## 6. Functional description

The SC16C550B provides serial asynchronous receive data synchronization, parallel-to-serial and serial-to-parallel data conversions for both the transmitter and receiver sections. These functions are necessary for converting the serial data stream into parallel data that is required with digital data systems. Synchronization for the serial data stream is accomplished by adding start and stop bits to the transmit data to form a data character (character orientated protocol). Data integrity is insured by attaching a parity bit to the data character. The parity bit is checked by the receiver for any transmission bit errors. The SC16C550B is fabricated with an advanced CMOS process to achieve low drain power and high speed requirements.

The SC16C550B is an upward solution that provides 16 bytes of transmit and receive FIFO memory, instead of none in the 16C450. The SC16C550B is designed to work with high speed modems and shared network environments that require fast data processing time. Increased performance is realized in the SC16C550B by the larger transmit and receive FIFOs. This allows the external processor to handle more networking tasks within a given time. In addition, the four selectable levels of FIFO trigger interrupt are provided for maximum data throughput performance, especially when operating in a multi-channel environment. The combination of the above greatly reduces the bandwidth requirement of the external controlling CPU, increases performance, and reduces power consumption.

The SC16C550B is capable of operation up to 3 Mbit/s with a 48 MHz external clock input (at 5 V).

## 6.1 Internal registers

The SC16C550B provides 12 internal registers for monitoring and control. These registers are shown in [Table 3](#). These registers function as data holding registers (THR/RHR), interrupt status and control registers (IER/ISR), a FIFO Control Register (FCR), line status and control registers (LCR/LSR), modem status and control registers (MCR/MSR), programmable data rate (clock) control registers (DLL/DLM), and a user accessible scratchpad register (SPR). Register functions are more fully described in the following paragraphs.

**Table 3. Internal registers decoding**

A2	A1	A0	Read mode	Write mode
<b>General register set (THR/RHR, IER/ISR, MCR/MSR, FCR/LSR, SPR)<sup>[1]</sup></b>				
0	0	0	Receive Holding Register	Transmit Holding Register
0	0	1	Interrupt Enable Register	Interrupt Enable Register
0	1	0	Interrupt Status Register	FIFO Control Register
0	1	1	Line Control Register	Line Control Register
1	0	0	Modem Control Register	Modem Control Register
1	0	1	Line Status Register	n/a
1	1	0	Modem Status Register	n/a
1	1	1	Scratchpad Register	Scratchpad Register
<b>Baud rate register set (DLL/DLM)<sup>[2]</sup></b>				
0	0	0	LSB of Divisor Latch	LSB of Divisor Latch
0	0	1	MSB of Divisor Latch	MSB of Divisor Latch

[1] These registers are accessible only when LCR[7] is a logic 0.

[2] These registers are accessible only when LCR[7] is a logic 1.

## 6.2 FIFO operation

The 16-byte transmit and receive data FIFOs are enabled by the FIFO Control Register bit 0 (FCR[0]). With 16C550 devices, the user can set the receive trigger level, but not the transmit trigger level. The receiver FIFO section includes a time-out function to ensure data is delivered to the external CPU. An interrupt is generated whenever the Receive Holding Register (RHR) has not been read following the loading of a character or the receive trigger level has not been reached.

**Table 4. Flow control mechanism**

Selected trigger level (characters)	INT pin activation	Negate RTS	Assert RTS
1	1	1	0
4	4	4	0
8	8	8	0
14	14	14	0

### 6.3 Autoflow control

Autoflow control is comprised of auto- $\overline{\text{CTS}}$  and auto- $\overline{\text{RTS}}$  (see Figure 6). With auto- $\overline{\text{CTS}}$ , the  $\overline{\text{CTS}}$  input must be active before the transmitter FIFO can emit data. With auto- $\overline{\text{RTS}}$ ,  $\overline{\text{RTS}}$  becomes active when the receiver needs more data and notifies the sending serial device. When  $\overline{\text{RTS}}$  is connected to  $\overline{\text{CTS}}$ , data transmission does not occur unless the receiver FIFO has space for the data; thus, overrun errors are eliminated using UART 1 and UART 2 from a SC16C550B with the autoflow control enabled. If not, overrun errors occur when the transmit data rate exceeds the receiver FIFO read latency.

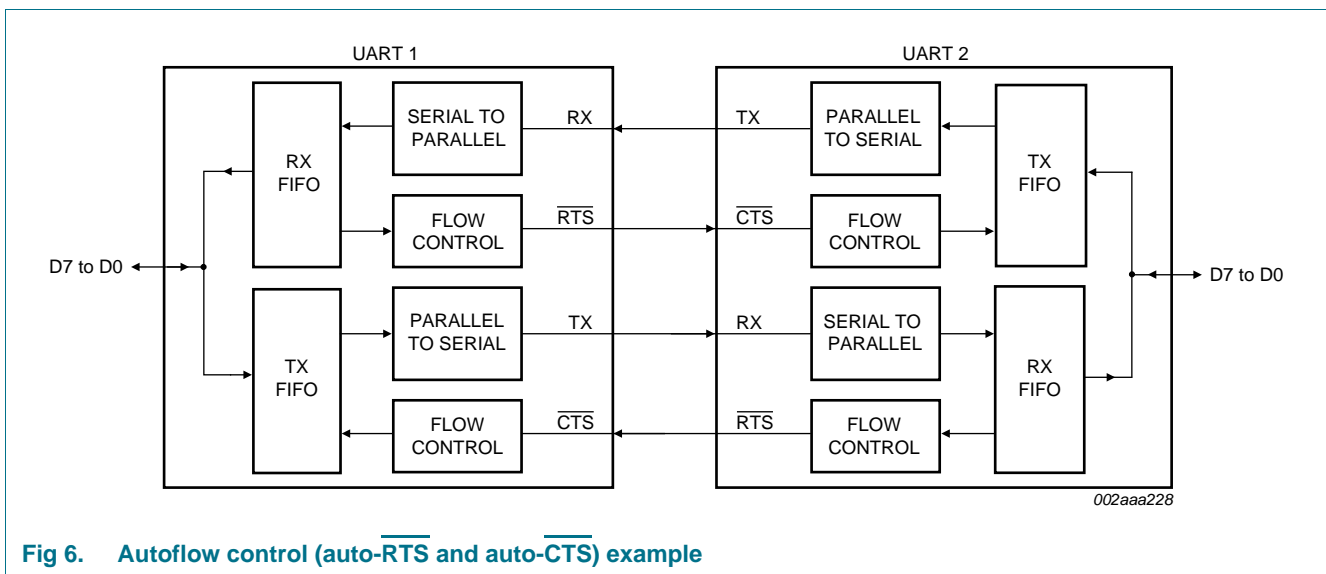

Fig 6. Autoflow control (auto- $\overline{\text{RTS}}$  and auto- $\overline{\text{CTS}}$ ) example

#### 6.3.1 Auto- $\overline{\text{RTS}}$

Auto- $\overline{\text{RTS}}$  data flow control originates in the receiver timing and control block (refer to Figure 1 “Block diagram of SC16C550B”) and is linked to the programmed receiver FIFO trigger level (see Figure 6). When the receiver FIFO level reaches a trigger level of 1, 4, or 8 (see Figure 8),  $\overline{\text{RTS}}$  is de-asserted. With trigger levels of 1, 4, and 8, the sending UART may send an additional byte after the trigger level is reached (assuming the sending UART has another byte to send) because it may not recognize the de-assertion of  $\overline{\text{RTS}}$  until after it has begun sending the additional byte.  $\overline{\text{RTS}}$  is automatically reasserted once the RX FIFO is emptied by reading the receiver buffer register. When the trigger level is 14 (see Figure 9),  $\overline{\text{RTS}}$  is de-asserted after the first data bit of the 16th character is present on the RX line.  $\overline{\text{RTS}}$  is reasserted when the RX FIFO has at least one available byte space.

#### 6.3.2 Auto- $\overline{\text{CTS}}$

The transmitter circuitry checks  $\overline{\text{CTS}}$  before sending the next data byte (see Figure 6). When  $\overline{\text{CTS}}$  is active, it sends the next byte. To stop the transmitter from sending the following byte,  $\overline{\text{CTS}}$  must be released before the middle of the last stop bit that is currently being sent (see Figure 7). The auto- $\overline{\text{CTS}}$  function reduces interrupts to the host system. When flow control is enabled,  $\overline{\text{CTS}}$  level changes do not trigger host interrupts because the device automatically controls its own transmitter. Without auto- $\overline{\text{CTS}}$ , the transmitter sends any data present in the transmit FIFO and a receiver overrun error may result.

### 6.3.3 Enabling autoflow control and auto-CTS

Autoflow control is enabled by setting MCR[5] and MCR[1].

Table 5. Enabling autoflow control and auto-CTS

MCR[5]	MCR[1]	Selection
1	1	auto $\overline{\text{RTS}}$ and $\overline{\text{CTS}}$
1	0	auto $\overline{\text{CTS}}$
0	X	disable

### 6.3.4 Auto-CTS and auto-RTS functional timing

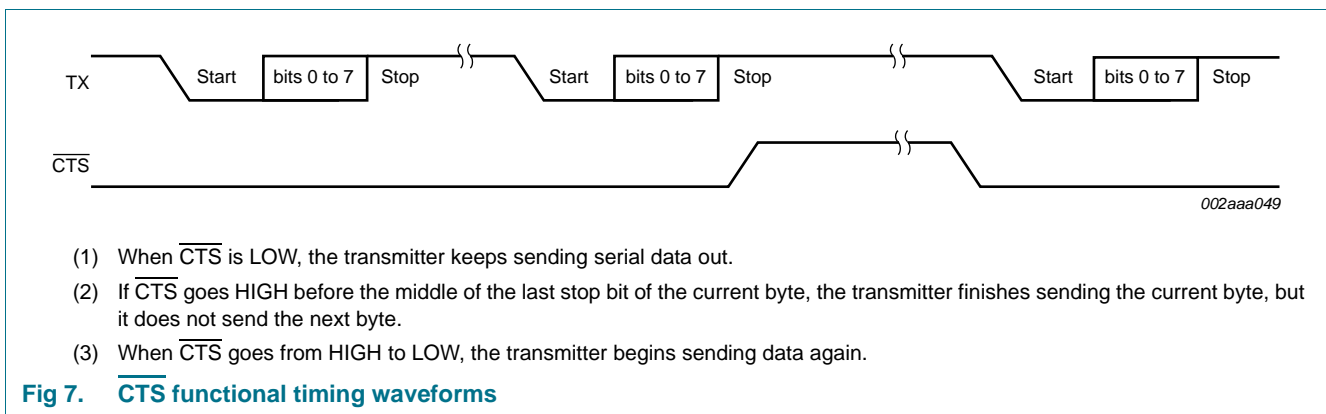

The receiver FIFO trigger level can be set to 1, 4, 8, or 14 bytes. These are described in [Figure 8](#) and [Figure 9](#).

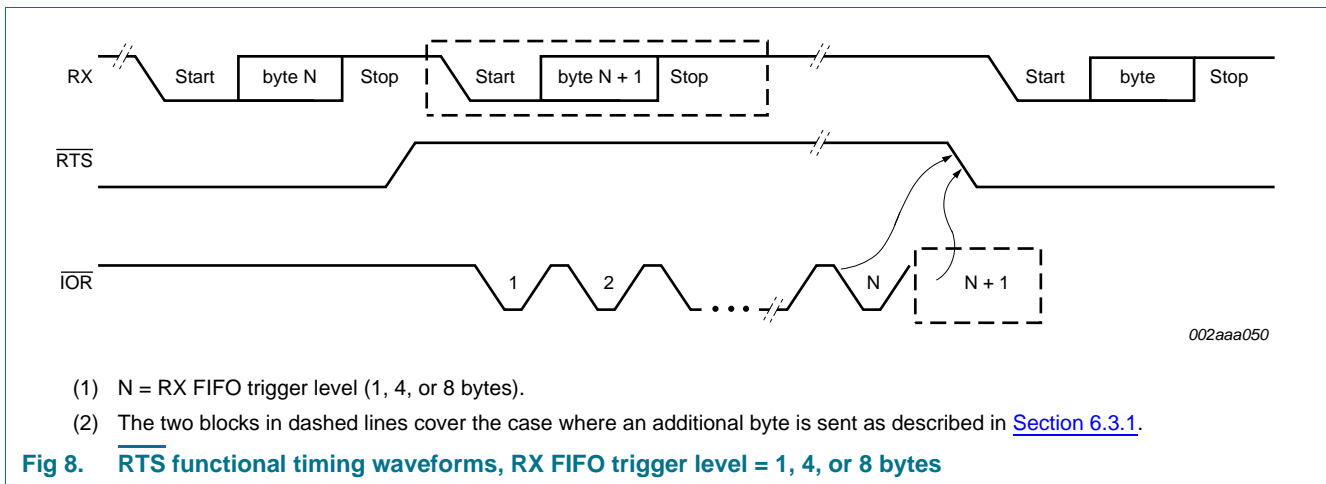

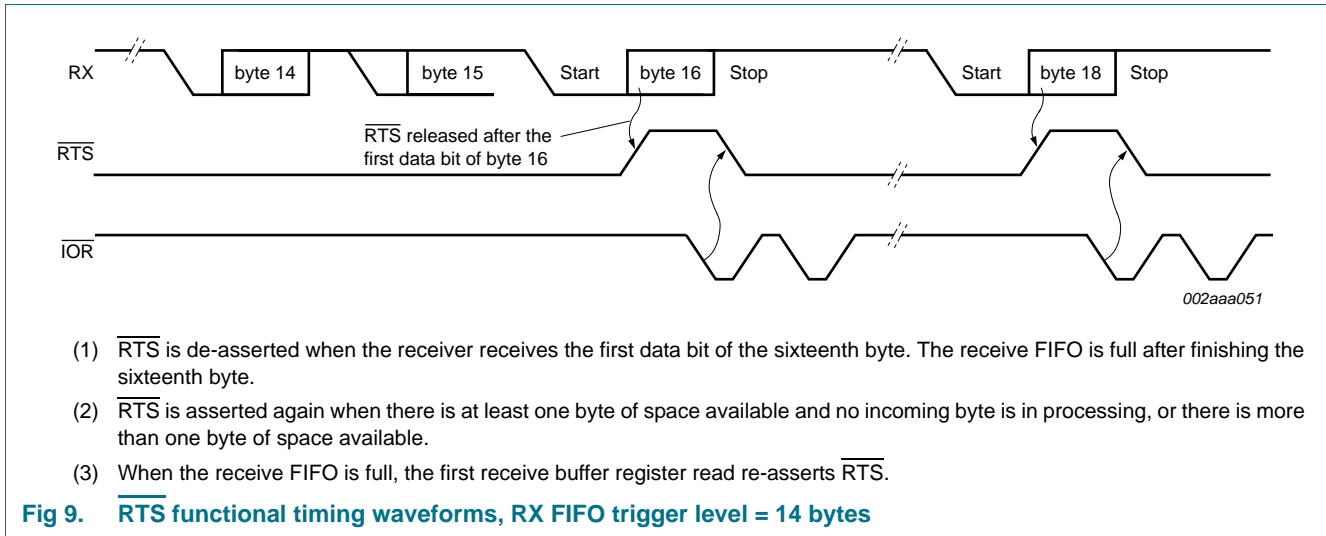

### 6.4 Hardware/software and time-out interrupts

Following a reset, the transmitter interrupt is enabled, the SC16C550B will issue an interrupt to indicate that the Transmit Holding Register is empty. This interrupt must be serviced prior to continuing operations. The ISR register provides the current singular highest priority interrupt only. Only after servicing the higher pending interrupt will the lower priority be reflected in the status register. Servicing the interrupt without investigating further interrupt conditions can result in data errors.

When two interrupt conditions have the same priority, it is important to service these interrupts correctly. Receive Data Ready and Receive Time-Out have the same interrupt priority (when enabled by IER[0]). The receiver issues an interrupt after the number of characters have reached the programmed trigger level. In this case, the SC16C550B FIFO may hold more characters than the programmed trigger level. Following the removal of a data byte, the user should re-check LSR[0] for additional characters. A Receive Time-Out will not occur if the receive FIFO is empty. The time-out counter is reset at the center of each stop bit received or each time the Receive Holding Register (RHR) is read. The actual time-out value is 4 character time, including data information length, start bit, parity bit, and the size of stop bit, that is, 1x, 1.5x, or 2x bit times.

### 6.5 Programmable baud rate generator

The SC16C550B supports high speed modem technologies that have increased input data rates by employing data compression schemes. For example, a 33.6 kbit/s modem that employs data compression may require a 115.2 kbit/s input data rate. A 128.0 kbit/s ISDN modem that supports data compression may need an input data rate of 460.8 kbit/s. The SC16C550B can support a standard data rate of 921.6 kbit/s.

A single baud rate generator is provided for the transmitter and receiver, allowing independent TX/RX channel control. The programmable baud rate generator is capable of accepting an input clock up to 48 MHz, as required for supporting a 3 Mbit/s data rate. The SC16C550B can be configured for internal or external clock operation. For internal clock oscillator operation, an industry standard microprocessor crystal is connected externally between the XTAL1 and XTAL2 pins (see [Figure 10](#)). Alternatively, an external clock can be connected to the XTAL1 pin to clock the internal baud rate generator for standard or custom rates (see [Table 6](#)).

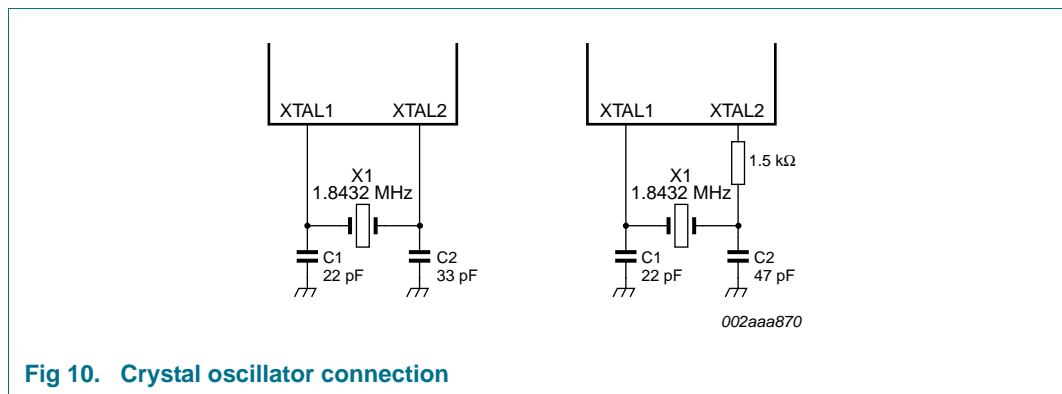

Fig 10. Crystal oscillator connection

The generator divides the input 16× clock by any divisor from 1 to (2<sup>16</sup> – 1). The SC16C550B divides the basic crystal or external clock by 16. The frequency of the BAUDOUT output pin is exactly 16× (16 times) the selected baud rate (BAUDOUT = 16 × baud rate). Customized baud rates can be achieved by selecting the proper divisor values for the MSB and LSB sections of the baud rate generator.

Programming the baud rate generator registers DLM (MSB) and DLL (LSB) provides a user capability for selecting the desired final baud rate. The examples in [Table 6](#) shows selectable baud rates when using a 1.8432 MHz crystal.

For custom baud rates, the divisor value can be calculated using the following equation:

$$divisor \text{ (in decimal)} = \frac{XTAL1 \text{ clock frequency}}{serial \text{ data rate} \times 16} \tag{1}$$

**Table 6. Baud rates using 1.8432 MHz or 3.072 MHz crystal**

Using 1.8432 MHz crystal			Using 3.072 MHz crystal		
Desired baud rate	Divisor for 16× clock	Baud rate error	Desired baud rate	Divisor for 16× clock	Baud rate error
50	2304		50	3840	
75	1536		75	2560	
110	1047	0.026	110	1745	0.026
134.5	857	0.058	134.5	1428	0.034
150	768		150	1280	
300	384		300	640	
600	192		600	320	
1200	96		1200	160	
1800	64		1800	107	0.312
2000	58	0.69	2000	96	
2400	48		2400	80	
3600	32		3600	53	0.628
4800	24		4800	40	
7200	16		7200	27	1.23
9600	12		9600	20	
19200	6		19200	10	
38400	3		38400	5	
56000	2	2.86			

## 6.6 DMA operation

The SC16C550B FIFO trigger level provides additional flexibility to the user for block mode operation. The user can optionally operate the transmit and receive FIFOs in the DMA mode (FCR[3]). The DMA mode affects the state of the  $\overline{\text{RXRDY}}$  and  $\overline{\text{TXRDY}}$  output pins. [Table 7](#) and [Table 8](#) show this.

**Remark:** DMA operation is not supported in the HVQFN32 package.

**Table 7. Effect of DMA mode on state of  $\overline{\text{RXRDY}}$  pin**

Non-DMA mode	DMA mode
1 = FIFO empty	0-to-1 transition when FIFO empties
0 = at least 1 byte in FIFO	1-to-0 transition when FIFO reaches trigger level, or time-out occurs

**Table 8. Effect of DMA mode on state of  $\overline{\text{TXRDY}}$  pin**

Non-DMA mode	DMA mode
1 = at least 1 byte in FIFO	1 = FIFO is full
0 = FIFO empty	0 = FIFO is empty

## 6.7 Loopback mode

The internal loopback capability allows on-board diagnostics. In the loopback mode, the normal modem interface pins are disconnected and reconfigured for loopback internally. MCR[3:0] register bits are used for controlling loopback diagnostic testing. In the loopback mode, OUT1 (bit 2) and OUT2 (bit 3) in the MCR register control the modem RI and DCD inputs, respectively. MCR signals DTR and RTS (bits 0:1) are used to control the modem CTS and DSR inputs, respectively. The transmitter output (TX) and the receiver input (RX) are disconnected from their associated interface pins, and instead are connected together internally (see [Figure 11](#)). The inputs CTS, DSR, DCD, and RI are disconnected from their normal modem control input pins, and instead are connected internally to DTR, RTS, OUT1 and OUT2. Loopback test data is entered into the transmit holding register via the user data bus interface, D0 to D7. The transmit UART serializes the data and passes the serial data to the receive UART via the internal loopback connection. The receive UART converts the serial data back into parallel data that is then made available at the user data interface D0 to D7. The user optionally compares the received data to the initial transmitted data for verifying error-free operation of the UART TX/RX circuits.

In this mode, the receiver and transmitter interrupts are fully operational. The Modem Control Interrupts are also operational. However, the interrupts can only be read using the lower four bits of the Modem Status Register (MSR[3:0]) instead of the four Modem Status Register bits 7:4. The interrupts are still controlled by the IER.

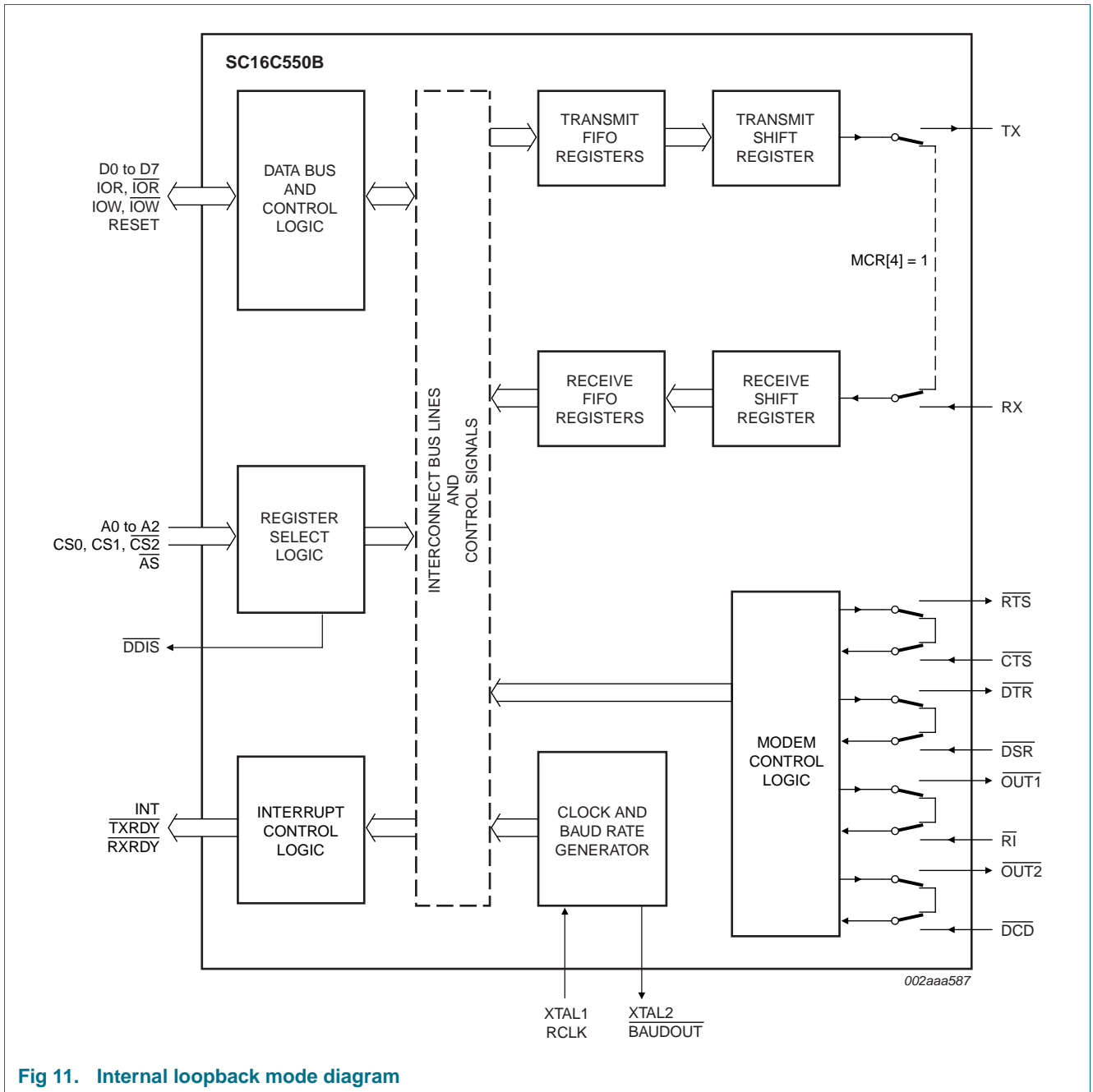

Fig 11. Internal loopback mode diagram

## 7. Register descriptions

[Table 9](#) details the assigned bit functions for the twelve SC16C550B internal registers. The assigned bit functions are more fully defined in [Section 7.1](#) through [Section 7.10](#).

**Table 9. SC16C550B internal registers**

A2	A1	A0	Register	Default <a href="#">[1]</a>	Bit 7	Bit 6	Bit 5	Bit 4	Bit 3	Bit 2	Bit 1	Bit 0
<b>General Register Set</b> <a href="#">[2]</a>												
0	0	0	RHR	XX	bit 7	bit 6	bit 5	bit 4	bit 3	bit 2	bit 1	bit 0
0	0	0	THR	XX	bit 7	bit 6	bit 5	bit 4	bit 3	bit 2	bit 1	bit 0
0	0	1	IER	00					modem status interrupt	receive line status interrupt	transmit holding register	receive holding register
0	1	0	FCR	00	RX trigger (MSB)	RX trigger (LSB)	reserved	reserved	DMA mode select <a href="#">[3]</a>	TX FIFO reset	RX FIFO reset	FIFO enable
0	1	0	ISR	01	FIFOs enabled	FIFOs enabled	0	0	INT priority bit 2	INT priority bit 1	INT priority bit 0	INT status
0	1	1	LCR	00	divisor latch enable	set break	set parity	even parity	parity enable	stop bits	word length bit 1	word length bit 0
1	0	0	MCR	00	reserved		auto flow control enable	loopback	$\overline{\text{OUT2}}$ , INT enable <a href="#">[4]</a>	$\overline{\text{OUT1}}$ <a href="#">[3]</a>	$\overline{\text{RTS}}$	$\overline{\text{DTR}}$
1	0	1	LSR	60	FIFO data error	transmit empty	transmit holding empty	break interrupt	framing error	parity error	overrun error	receive data ready
1	1	0	MSR	X0	DCD	RI	DSR	CTS	$\Delta\overline{\text{DCD}}$	$\Delta\overline{\text{RI}}$	$\Delta\overline{\text{DSR}}$	$\Delta\overline{\text{CTS}}$
1	1	1	SPR	FF	bit 7	bit 6	bit 5	bit 4	bit 3	bit 2	bit 1	bit 0
<b>Special Register Set</b> <a href="#">[5]</a>												
0	0	0	DLL	XX	bit 7	bit 6	bit 5	bit 4	bit 3	bit 2	bit 1	bit 0
0	0	1	DLM	XX	bit 15	bit 14	bit 13	bit 12	bit 11	bit 10	bit 9	bit 8

[1] The value shown represents the register's initialized hexadecimal value; X = not applicable.

[2] These registers are accessible only when LCR[7] is set to a logic 0.

[3] These functions are not supported in the HVQFN32 package, and should not be written.

[4]  $\overline{\text{OUT2}}$  pin is not supported in the HVQFN32 package. MCR3 is INT enabled in the HVQFN32 package. INT is always enabled in DIP40, PLCC44 and LQFP48 packages.

[5] The Special Register set is accessible only when LCR[7] is set to a logic 1.

### 7.1 Transmit Holding Register (THR) and Receive Holding Register (RHR)

The serial transmitter section consists of an 8-bit Transmit Holding Register (THR) and Transmit Shift Register (TSR). The status of the THR is provided in the Line Status Register (LSR). Writing to the THR transfers the contents of the data bus (D[7:0]) to the THR, providing that the THR or TSR is empty. The THR empty flag in the LSR register will be set to a logic 1 when the transmitter is empty or when data is transferred to the TSR. Note that a write operation can be performed when the THR empty flag is set (logic 0 = FIFO full; logic 1 = at least one FIFO location available).

The serial receive section also contains an 8-bit Receive Holding Register (RHR). Receive data is removed from the SC16C550B and receive FIFO by reading the RHR register. The receive section provides a mechanism to prevent false starts. On the falling edge of a start or false start bit, an internal receiver counter starts counting clocks at the 16x clock rate. After 7½ clocks, the start bit time should be shifted to the center of the start bit. At this time the start bit is sampled, and if it is still a logic 0 it is validated. Evaluating the start bit in this manner prevents the receiver from assembling a false character. Receiver status codes will be posted in the LSR.

### 7.2 Interrupt Enable Register (IER)

The Interrupt Enable Register (IER) masks the interrupts from receiver ready, transmitter empty, line status and modem status registers. These interrupts would normally be seen on the INT output pin.

**Table 10. Interrupt Enable Register bits description**

Bit	Symbol	Description
7:4	IER[7:4]	not used
3	IER[3]	Modem Status Interrupt. logic 0 = disable the modem status register interrupt (normal default condition) logic 1 = enable the modem status register interrupt
2	IER[2]	Receive Line Status interrupt. This interrupt will be issued whenever a fully assembled receive character is transferred from RSR to the RHR/FIFO, that is, data ready, LSR[0]. logic 0 = disable the receiver line status interrupt (normal default condition) logic 1 = enable the receiver line status interrupt
1	IER[1]	Transmit Holding Register interrupt. This interrupt will be issued whenever the THR is empty, and is associated with LSR[1]. logic 0 = disable the transmitter empty interrupt (normal default condition) logic 1 = enable the transmitter empty interrupt
0	IER[0]	Receive Holding Register interrupt. This interrupt will be issued when the FIFO has reached the programmed trigger level, or is cleared when the FIFO drops below the trigger level in the FIFO mode of operation. logic 0 = disable the receiver ready interrupt (normal default condition) logic 1 = enable the receiver ready interrupt

### 7.2.1 IER versus Receive FIFO interrupt mode operation

When the receive FIFO (FCR[0] = logic 1), and receive interrupts (IER[0] = logic 1) are enabled, the receive interrupts and register status will reflect the following:

- The receive data available interrupts are issued to the external CPU when the FIFO has reached the programmed trigger level. It will be cleared when the FIFO drops below the programmed trigger level.
- FIFO status will also be reflected in the user accessible ISR register when the FIFO trigger level is reached. Both the ISR register status bit and the interrupt will be cleared when the FIFO drops below the trigger level.
- The data ready bit (LSR[0]) is set as soon as a character is transferred from the shift register to the receive FIFO. It is reset when the FIFO is empty.

### 7.2.2 IER versus Receive/Transmit FIFO polled mode operation

When FCR[0] = logic 1, resetting IER[0:3] enables the SC16C550B in the FIFO polled mode of operation. Since the receiver and transmitter have separate bits in the LSR, either or both can be used in the polled mode by selecting respective transmit or receive control bit(s).

- LSR[0] will be a logic 1 as long as there is one byte in the receive FIFO.
- LSR[1:4] will provide the type of errors encountered, if any.
- LSR[5] will indicate when the transmit FIFO is empty.
- LSR[6] will indicate when both the transmit FIFO and transmit shift register are empty.
- LSR[7] will indicate any FIFO data errors.

## 7.3 FIFO Control Register (FCR)

This register is used to enable the FIFOs, clear the FIFOs, set the receive FIFO trigger levels, and select the DMA mode.

### 7.3.1 DMA mode

(DMA mode does not exist in the HVQFN32 package; see [Table 9](#).)

#### 7.3.1.1 Mode 0 (FCR bit 3 = 0)

Set and enable the interrupt for each single transmit or receive operation, and is similar to the 16C450 mode. Transmit Ready ( $\overline{\text{TXRDY}}$ ) will go to a logic 0 whenever an empty transmit space is available in the Transmit Holding Register (THR). Receive Ready ( $\overline{\text{RXRDY}}$ ) will go to a logic 0 whenever the Receive Holding Register (RHR) is loaded with a character.

#### 7.3.1.2 Mode 1 (FCR bit 3 = 1)

Set and enable the interrupt in a block mode operation. The transmit interrupt is set when the transmit FIFO is empty. The receive interrupt is set when the receive FIFO fills to the programmed trigger level. However, the FIFO continues to fill regardless of the programmed level until the FIFO is full.  $\overline{\text{RXRDY}}$  remains a logic 0 as long as the FIFO fill level is above the programmed trigger level.

### 7.3.2 FIFO mode

Table 11. FIFO Control Register bits description

Bit	Symbol	Description
7:6	FCR[7] (MSB), FCR[6] (LSB)	<p>RX trigger. These bits are used to set the trigger level for the receive FIFO interrupt.</p> <p>An interrupt is generated when the number of characters in the FIFO equals the programmed trigger level. However, the FIFO will continue to be loaded until it is full. Refer to <a href="#">Table 12</a>.</p>
5:4	FCR[5] (MSB), FCR[4] (LSB)	not used; set to 00
3	FCR[3]	<p>DMA mode select.</p> <p>logic 0 = set DMA mode '0' (normal default condition)</p> <p>logic 1 = set DMA mode '1'</p> <p><b>Transmit operation in mode '0':</b> When the SC16C550B is in the 16C450 mode (FIFOs disabled; FCR[0] = logic 0) or in the FIFO mode (FIFOs enabled; FCR[0] = logic 1; FCR[3] = logic 0), and when there are no characters in the transmit FIFO or transmit holding register, the <math>\overline{\text{TXRDY}}</math> pin will be a logic 0. Once active, the <math>\overline{\text{TXRDY}}</math> pin will go to a logic 1 after the first character is loaded into the transmit holding register.</p> <p><b>Receive operation in mode '0':</b> When the SC16C550B is in 16C450 mode, or in the FIFO mode (FCR[0] = logic 1; FCR[3] = logic 0) and there is at least one character in the receive FIFO, the <math>\overline{\text{RXRDY}}</math> pin will be a logic 0. Once active, the <math>\overline{\text{RXRDY}}</math> pin will go to a logic 1 when there are no more characters in the receiver.</p> <p><b>Transmit operation in mode '1':</b> When the SC16C550B is in FIFO mode (FCR[0] = logic 1; FCR[3] = logic 1), the <math>\overline{\text{TXRDY}}</math> pin will be a logic 1 when the transmit FIFO is completely full. It will be a logic 0 if the transmit FIFO is completely empty.</p> <p><b>Receive operation in mode '1':</b> When the SC16C550B is in FIFO mode (FCR[0] = logic 1; FCR[3] = logic 1) and the trigger level has been reached, or a Receive Time-Out has occurred, the <math>\overline{\text{RXRDY}}</math> pin will go to a logic 0. Once activated, it will go to a logic 1 after there are no more characters in the FIFO.</p>
2	FCR[2]	<p>TX FIFO reset.</p> <p>logic 0 = no FIFO transmit reset (normal default condition)</p> <p>logic 1 = clears the contents of the transmit FIFO and resets the FIFO counter logic (the transmit shift register is not cleared or altered). This bit will return to a logic 0 after clearing the FIFO.</p>
1	FCR[1]	<p>RX FIFO reset.</p> <p>logic 0 = no FIFO receive reset (normal default condition)</p> <p>logic 1 = clears the contents of the receive FIFO and resets the FIFO counter logic (the receive shift register is not cleared or altered). This bit will return to a logic 0 after clearing the FIFO.</p>
0	FCR[0]	<p>FIFO enable.</p> <p>logic 0 = disable the transmit and receive FIFO (normal default condition)</p> <p>logic 1 = enable the transmit and receive FIFO. <b>This bit must be a '1' when other FCR bits are written to, or they will not be programmed.</b></p>

Table 12. RX trigger levels

FCR[7]	FCR[6]	RX FIFO trigger level (bytes)
0	0	1
0	1	4
1	0	8
1	1	14

## 7.4 Interrupt Status Register (ISR)

The SC16C550B provides four levels of prioritized interrupts to minimize external software interaction. The Interrupt Status Register (ISR) provides the user with four interrupt status bits. Performing a read cycle on the ISR will provide the user with the highest pending interrupt level to be serviced. No other interrupts are acknowledged until the pending interrupt is serviced. Whenever the interrupt status register is read, the interrupt status is cleared. However, it should be noted that only the current pending interrupt is cleared by the read. A lower level interrupt may be seen after re-reading the interrupt status bits.

[Table 13 "Interrupt source"](#) shows the data values (bits 3:0) for the four prioritized interrupt levels and the interrupt sources associated with each of these interrupt levels.

Table 13. Interrupt source

Priority level	ISR[3]	ISR[2]	ISR[1]	ISR[0]	Source of the interrupt
1	0	1	1	0	LSR (Receiver Line Status Register)
2	0	1	0	0	RXRDY (Received Data Ready)
2	1	1	0	0	RXRDY (Receive Data time-out)
3	0	0	1	0	TXRDY (Transmitter Holding Register Empty)
4	0	0	0	0	MSR (Modem Status Register)

Table 14. Interrupt Status Register bits description

Bit	Symbol	Description
7:6	ISR[7:6]	FIFOs enabled. These bits are set to a logic 0 when the FIFO is not being used. They are set to a logic 1 when the FIFOs are enabled. logic 0 or cleared = default condition
5:4	ISR[5:4]	not used
3:1	ISR[3:1]	INT priority bits 2:0. These bits indicate the source for a pending interrupt at interrupt priority levels 1, 2, and 3 (see <a href="#">Table 13</a> ). logic 0 or cleared = default condition
0	ISR[0]	INT status. logic 0 = an interrupt is pending and the ISR contents may be used as a pointer to the appropriate interrupt service routine logic 1 = no interrupt pending (normal default condition)

## 7.5 Line Control Register (LCR)

The Line Control Register is used to specify the asynchronous data communication format. The word length, the number of stop bits, and the parity are selected by writing the appropriate bits in this register.

**Table 15. Line Control Register bits description**

Bit	Symbol	Description
7	LCR[7]	Divisor latch enable. The internal baud rate counter latch and Enhance Feature mode enable. logic 0 = divisor latch disabled (normal default condition) logic 1 = divisor latch and enhanced feature register enabled
6	LCR[6]	Set break. When enabled, the Break control bit causes a break condition to be transmitted (the TX output is forced to a logic 0 state). This condition exists until disabled by setting LCR[6] to a logic 0. logic 0 = no TX break condition (normal default condition) logic 1 = forces the transmitter output (TX) to a logic 0 for alerting the remote receiver to a line break condition
5	LCR[5]	Set parity. If the parity bit is enabled, LCR[5] selects the forced parity format. Programs the parity conditions (see <a href="#">Table 16</a> ). logic 0 = parity is not forced (normal default condition) LCR[5] = logic 1 and LCR[4] = logic 0: parity bit is forced to a logical 1 for the transmit and receive data LCR[5] = logic 1 and LCR[4] = logic 1: parity bit is forced to a logical 0 for the transmit and receive data
4	LCR[4]	Even parity. If the parity bit is enabled with LCR[3] set to a logic 1, LCR[4] selects the even or odd parity format. logic 0 = odd parity is generated by forcing an odd number of logic 1s in the transmitted data. The receiver must be programmed to check the same format (normal default condition). logic 1 = even parity is generated by forcing an even number of logic 1s in the transmitted data. The receiver must be programmed to check the same format.
3	LCR[3]	Parity enable. Parity or no parity can be selected via this bit. logic 0 = no parity (normal default condition) logic 1 = a parity bit is generated during the transmission, receiver checks the data and parity for transmission errors
2	LCR[2]	Stop bits. The length of stop bit is specified by this bit in conjunction with the programmed word length (see <a href="#">Table 17</a> ). logic 0 or cleared = default condition
1:0	LCR[1:0]	Word length bits [1:0]. These two bits specify the word length to be transmitted or received (see <a href="#">Table 18</a> ). logic 0 or cleared = default condition

**Table 16. LCR[5] parity selection**

LCR[5]	LCR[4]	LCR[3]	Parity selection
X	X	0	no parity
0	0	1	odd parity
0	1	1	even parity
1	0	1	forced parity '1'
1	1	1	forced parity '0'

**Table 17. LCR[2] stop bit length**

LCR[2]	Word length	Stop bit length (bit times)
0	5, 6, 7, 8	1
1	5	1½
1	6, 7, 8	2

**Table 18. LCR[1:0] word length**

LCR[1]	LCR[0]	Word length
0	0	5
0	1	6
1	0	7
1	1	8

## 7.6 Modem Control Register (MCR)

This register controls the interface with the modem or a peripheral device.

**Table 19. Modem Control Register bits description**

Bit	Symbol	Description
7	MCR[7]	reserved; set to '0'
6	MCR[6]	reserved; set to '0'
5	MCR[5]	Auto flow control enable.
4	MCR[4]	Loopback. Enable the local loopback mode (diagnostics). In this mode the transmitter output (TX) and the receiver input (RX), $\overline{\text{CTS}}$ , $\overline{\text{DSR}}$ , $\overline{\text{DCD}}$ , and $\overline{\text{RI}}$ are disconnected from the SC16C550B I/O pins. Internally the modem data and control pins are connected into a loopback data configuration (see <a href="#">Figure 11</a> ). In this mode, the receiver and transmitter interrupts remain fully operational. The Modem Control Interrupts are also operational, but the interrupts' sources are switched to the lower four bits of the Modem Control. Interrupts continue to be controlled by the IER register. logic 0 = disable loopback mode (normal default condition) logic 1 = enable local loopback mode (diagnostics)
3	MCR[3]	$\overline{\text{OUT2}}$ . Used to control the modem $\overline{\text{DCD}}$ signal in the loopback mode. logic 0 = $\overline{\text{OUT2}}$ is at logic 1. In the loopback mode, sets $\overline{\text{OUT2}}$ ( $\overline{\text{DCD}}$ ) internally to a logic 1. logic 1 = $\overline{\text{OUT2}}$ is at logic 0. In the loopback mode, sets $\overline{\text{OUT2}}$ ( $\overline{\text{DCD}}$ ) internally to a logic 0.
2	MCR[2]	$\overline{\text{OUT1}}$ . This bit is used in the Loopback mode only. In the loopback mode, this bit is used to write the state of the modem $\overline{\text{RI}}$ interface signal via $\overline{\text{OUT1}}$ .
1	MCR[1]	$\overline{\text{RTS}}$ logic 0 = force $\overline{\text{RTS}}$ output to a logic 1 (normal default condition) logic 1 = force $\overline{\text{RTS}}$ output to a logic 0
0	MCR[0]	$\overline{\text{DTR}}$ logic 0 = force $\overline{\text{DTR}}$ output to a logic 1 (normal default condition) logic 1 = force $\overline{\text{DTR}}$ output to a logic 0

## 7.7 Line Status Register (LSR)

This register provides the status of data transfers between the SC16C550B and the CPU.

**Table 20. Line Status Register bits description**

Bit	Symbol	Description
7	LSR[7]	FIFO data error. logic 0 = no error (normal default condition) logic 1 = at least one parity error, framing error or break indication is in the current FIFO data. This bit is cleared when LSR register is read.
6	LSR[6]	THR and TSR empty. This bit is the Transmit Empty indicator. This bit is set to a logic 1 whenever the transmit holding register and the transmit shift register are both empty. It is reset to logic 0 whenever either the THR or TSR contains a data character. In the FIFO mode, this bit is set to '1' whenever the transmit FIFO and transmit shift register are both empty.
5	LSR[5]	THR empty. This bit is the Transmit Holding Register Empty indicator. This bit indicates that the UART is ready to accept a new character for transmission. In addition, this bit causes the UART to issue an interrupt to CPU when the THR interrupt enable is set. The THR bit is set to a logic 1 when a character is transferred from the transmit holding register into the transmitter shift register. The bit is reset to a logic 0 concurrently with the loading of the transmitter holding register by the CPU. In the FIFO mode, this bit is set when the transmit FIFO is empty; it is cleared when at least 1 byte is written to the transmit FIFO.
4	LSR[4]	Break interrupt. logic 0 = no break condition (normal default condition) logic 1 = the receiver received a break signal (RX was a logic 0 for one character frame time). In the FIFO mode, only one break character is loaded into the FIFO.
3	LSR[3]	Framing error. logic 0 = no framing error (normal default condition) logic 1 = framing error. The receive character did not have a valid stop bit(s). In the FIFO mode, this error is associated with the character at the top of the FIFO.
2	LSR[2]	Parity error. logic 0 = no parity error (normal default condition) logic 1 = parity error. The receive character does not have correct parity information and is suspect. In the FIFO mode, this error is associated with the character at the top of the FIFO.
1	LSR[1]	Overrun error. logic 0 = no overrun error (normal default condition) logic 1 = overrun error. A data overrun error occurred in the receive shift register. This happens when additional data arrives while the FIFO is full. In this case, the previous data in the shift register is overwritten. Note that under this condition, the data byte in the receive shift register is not transferred into the FIFO, therefore the data in the FIFO is not corrupted by the error.
0	LSR[0]	Receive data ready. logic 0 = no data in receive holding register or FIFO (normal default condition) logic 1 = data has been received and is saved in the receive holding register or FIFO

## 7.8 Modem Status Register (MSR)

This register provides the current state of the control interface signals from the modem, or other peripheral device to which the SC16C550B is connected. Four bits of this register are used to indicate the changed information. These bits are set to a logic 1 whenever a control input from the modem changes state. These bits are set to a logic 0 whenever the CPU reads this register.

**Table 21. Modem Status Register bits description**

Bit	Symbol	Description
7	MSR[7]	<b>Data Carrier Detect.</b> DCD (active HIGH, logical 1). Normally this bit is the complement of the $\overline{\text{DCD}}$ input. In the loopback mode this bit is equivalent to the OUT2 bit in the MCR register.
6	MSR[6]	<b>Ring Indicator.</b> RI (active HIGH, logical 1). Normally this bit is the complement of the $\overline{\text{RI}}$ input. In the loopback mode this bit is equivalent to the OUT1 bit in the MCR register.
5	MSR[5]	<b>Data Set Ready.</b> DSR (active HIGH, logical 1). Normally this bit is the complement of the $\overline{\text{DSR}}$ input. In loopback mode this bit is equivalent to the DTR bit in the MCR register.
4	MSR[4]	<b>Clear To Send.</b> CTS. $\overline{\text{CTS}}$ functions as hardware flow control signal input if it is enabled via MCR[5]. The transmit holding register flow control is enabled/disabled by MSR[4]. Flow control (when enabled) allows starting and stopping the transmissions based on the external modem $\overline{\text{CTS}}$ signal. A logic 1 at the $\overline{\text{CTS}}$ pin will stop SC16C550B transmissions as soon as current character has finished transmission. Normally MSR[4] is the complement of the $\overline{\text{CTS}}$ input. However, in the loopback mode, this bit is equivalent to the RTS bit in the MCR register.
3	MSR[3]	$\Delta\overline{\text{DCD}}$ <sup>[1]</sup> logic 0 = no $\overline{\text{DCD}}$ change (normal default condition) logic 1 = the $\overline{\text{DCD}}$ input to the SC16C550B has changed state since the last time it was read. A modem Status Interrupt will be generated.
2	MSR[2]	$\Delta\overline{\text{RI}}$ <sup>[1]</sup> logic 0 = no $\overline{\text{RI}}$ change (normal default condition). logic 1 = the $\overline{\text{RI}}$ input to the SC16C550B has changed from a logic 0 to a logic 1. A modem Status Interrupt will be generated.
1	MSR[1]	$\Delta\overline{\text{DSR}}$ <sup>[1]</sup> logic 0 = no $\overline{\text{DSR}}$ change (normal default condition) logic 1 = the $\overline{\text{DSR}}$ input to the SC16C550B has changed state since the last time it was read. A modem Status Interrupt will be generated.
0	MSR[0]	$\Delta\overline{\text{CTS}}$ <sup>[1]</sup> logic 0 = no $\overline{\text{CTS}}$ change (normal default condition) logic 1 = the $\overline{\text{CTS}}$ input to the SC16C550B has changed state since the last time it was read. A modem Status Interrupt will be generated.

[1] Whenever any MSR bit 0:3 is set to logic 1, a Modem Status Interrupt will be generated.

## 7.9 Scratchpad Register (SPR)

The SC16C550B provides a temporary data register to store 8 bits of user information.

## 7.10 SC16C550B external reset conditions

Table 22. Reset state for registers

Register	Reset state
IER	IER[7:0] = 0
ISR	ISR[7:1] = 0; ISR[0] = 1
LCR	LCR[7:0] = 0
MCR	MCR[7:0] = 0
LSR	LSR[7] = 0; LSR[6:5] = 1; LSR[4:0] = 0
MSR	MSR[7:4] = input signals; MSR[3:0] = 0
FCR	FCR[7:0] = 0

Table 23. Reset state for outputs

Output	Reset state
TX	HIGH
$\overline{\text{RTS}}$	HIGH
$\overline{\text{DTR}}$	HIGH
$\overline{\text{RXRDY}}$	HIGH
$\overline{\text{TXRDY}}$	LOW

## 8. Limiting values

Table 24. Limiting values

In accordance with the Absolute Maximum Rating System (IEC 60134).

Symbol	Parameter	Conditions	Min	Max	Unit
$V_{\text{DD}}$	supply voltage		-	7	V
$V_{\text{n}}$	voltage on any other pin	at D7 to D0 pins	$V_{\text{SS}} - 0.3$	$V_{\text{DD}} + 0.3$	V
		at any input only pin	$V_{\text{SS}} - 0.3$	5.3	V
$T_{\text{amb}}$	ambient temperature	operating in free air	-40	+85	°C
$T_{\text{stg}}$	storage temperature		-65	+150	°C
$P_{\text{tot/pack}}$	total power dissipation per package		-	500	mW

## 9. Static characteristics

**Table 25. Static characteristics**

$T_{amb} = -40\text{ }^{\circ}\text{C}$  to  $+85\text{ }^{\circ}\text{C}$ ; tolerance of  $V_{DD} = \pm 10\%$ , unless otherwise specified.

Symbol	Parameter	Conditions	$V_{DD} = 2.5\text{ V}$		$V_{DD} = 3.3\text{ V}$		$V_{DD} = 5.0\text{ V}$		Unit
			Min	Max	Min	Max	Min	Max	
$V_{IL(\text{clk})}$	clock LOW-level input voltage		-0.3	+0.45	-0.3	+0.6	-0.5	+0.6	V
$V_{IH(\text{clk})}$	clock HIGH-level input voltage		1.8	$V_{DD}$	2.4	$V_{DD}$	3.0	$V_{DD}$	V
$V_{IL}$	LOW-level input voltage		-0.3	+0.65	-0.3	+0.8	-0.5	+0.8	V
$V_{IH}$	HIGH-level input voltage		1.6	-	2.0	-	2.2	$V_{DD}$	V
$V_{OL}$	LOW-level output voltage	on all outputs <a href="#">[1]</a>							
		$I_{OL} = 5\text{ mA}$ (data bus)	-	-	-	-	-	0.4	V
		$I_{OL} = 4\text{ mA}$ (other outputs)	-	-	-	0.4	-	-	V
		$I_{OL} = 2\text{ mA}$ (data bus)	-	0.4	-	-	-	-	V
$V_{OH}$	HIGH-level output voltage	$I_{OH} = -5\text{ mA}$ (data bus)	-	-	-	-	2.4	-	V
		$I_{OH} = -1\text{ mA}$ (other outputs)	-	-	2.0	-	-	-	V
		$I_{OH} = -800\text{ }\mu\text{A}$ (data bus)	1.85	-	-	-	-	-	V
		$I_{OH} = -400\text{ }\mu\text{A}$ (other outputs)	1.85	-	-	-	-	-	V
$I_{LIL}$	LOW-level input leakage current		-	$\pm 10$	-	$\pm 10$	-	$\pm 10$	$\mu\text{A}$
$I_{L(\text{clk})}$	clock leakage current		-	$\pm 30$	-	$\pm 30$	-	$\pm 30$	$\mu\text{A}$
$I_{DD(AV)}$	average supply current	$f = 5\text{ MHz}$	-	3.5	-	4.5	-	4.5	mA
$C_i$	input capacitance		-	5	-	5	-	5	pF
$R_{pu(\text{int})}$	internal pull-up resistance		500	-	500	-	500	-	k $\Omega$

[1] Except for XTAL2,  $V_{OL} = 1\text{ V}$  typically.

## 10. Dynamic characteristics

Table 26. Dynamic characteristics

$T_{amb} = -40\text{ }^{\circ}\text{C}$  to  $+85\text{ }^{\circ}\text{C}$ ; tolerance of  $V_{DD} \pm 10\%$ , unless otherwise specified.

Symbol	Parameter	Conditions	$V_{DD} = 2.5\text{ V}$		$V_{DD} = 3.3\text{ V}$		$V_{DD}$ Min	Min
			Min	Max	Min	Max		
$t_{w1}$	clock pulse duration		15	-	13	-	-	10
$t_{w2}$	clock pulse duration		15	-	13	-	-	10
$f_{XTAL}$	clock frequency	[1][2]	-	16	-	32	-	-
$t_{4w}$	address strobe width		45	-	35	-	-	25
$t_{5s}$	address setup time		5	-	5	-	-	1
$t_{5h}$	address hold time		5	-	5	-	-	5
$t_{6s}$	chip select setup time to $\overline{AS}$		10	-	5	-	-	0
$t_{6h}$	address hold time		0	-	0	-	-	0
$t_{6s'}$	address setup time	[3]	10	-	10	-	-	5
$t_{6h}$	chip select hold time		0	-	0	-	-	0
$t_{7d}$	$\overline{IOR}$ delay from chip select		10	-	10	-	-	10
$t_{7w}$	$\overline{IOR}$ strobe width	25 pF load	77	-	26	-	-	23
$t_{7h}$	chip select hold time from $\overline{IOR}$		0	-	0	-	-	0
$t_{7h'}$	address hold time	[3]	5	-	5	-	-	5
$t_{8d}$	$\overline{IOR}$ delay from address		10	-	10	-	-	10
$t_{9d}$	read cycle delay	25 pF load	20	-	20	-	-	20
$t_{11d}$	$\overline{IOR}$ to $\overline{DDIS}$ delay	25 pF load	-	100	-	35	-	-
$t_{12d}$	delay from $\overline{IOR}$ to data	25 pF load	-	77	-	26	-	-
$t_{12h}$	data disable time	25 pF load	-	15	-	15	-	-
$t_{13d}$	$\overline{IOW}$ delay from chip select		10	-	10	-	-	10
$t_{13w}$	$\overline{IOW}$ strobe width		20	-	20	-	-	15
$t_{13h}$	chip select hold time from $\overline{IOW}$		0	-	0	-	-	0
$t_{14d}$	$\overline{IOW}$ delay from address		10	-	10	-	-	10
$t_{15d}$	write cycle delay		25	-	25	-	-	20
$t_{16s}$	data setup time		20	-	20	-	-	15
$t_{16h}$	data hold time		15	-	5	-	-	5
$t_{17d}$	delay from $\overline{IOW}$ to output	25 pF load	-	100	-	33	-	-

**Table 26. Dynamic characteristics ...continued**  
 $T_{amb} = -40\text{ }^{\circ}\text{C}$  to  $+85\text{ }^{\circ}\text{C}$ ; tolerance of  $V_{DD} \pm 10\%$ , unless otherwise specified.

Symbol	Parameter	Conditions	$V_{DD} = 2.5\text{ V}$		$V_{DD} = 3.3\text{ V}$		$V_{DD}$
			Min	Max	Min	Max	
$t_{18d}$	delay to set interrupt from Modem input	25 pF load	-	100	-	24	-
$t_{19d}$	delay to reset interrupt from $\overline{\text{IOR}}$	25 pF load	-	100	-	24	-
$t_{20d}$	delay from stop to set interrupt		-	$1T_{RCLK}$	-	$1T_{RCLK}$	-
$t_{21d}$	delay from $\overline{\text{IOR}}$ to reset interrupt	25 pF load	-	100	-	29	-
$t_{22d}$	delay from start to set interrupt		-	100	-	45	-
$t_{23d}$	delay from $\overline{\text{IOW}}$ to transmit start		$8T_{RCLK}$	$24T_{RCLK}$	$8T_{RCLK}$	$24T_{RCLK}$	$8T_{RCLK}$
$t_{24d}$	delay from $\overline{\text{IOW}}$ to reset interrupt		-	100	-	45	-
$t_{25d}$	delay from stop to set $\overline{\text{RXRDY}}$		-	$1T_{RCLK}$	-	$1T_{RCLK}$	-
$t_{26d}$	delay from $\overline{\text{IOR}}$ to reset $\overline{\text{RXRDY}}$		-	100	-	45	-
$t_{27d}$	delay from $\overline{\text{IOW}}$ to set $\overline{\text{TXRDY}}$		-	100	-	45	-
$t_{28d}$	delay from start to reset $\overline{\text{TXRDY}}$		-	$8T_{RCLK}$	-	$8T_{RCLK}$	-
$t_{\text{RESET}}$	RESET pulse width		[4] 100	-	40	-	40
N	baud rate divisor		1	$2^{16} - 1$	1	$2^{16} - 1$	1

[1] Applies to external clock, crystal oscillator max 24 MHz.

[2] Maximum frequency =  $\frac{f}{f_{W,3}}$

[3] Applicable only when  $\overline{\text{AS}}$  is tied LOW.

[4] RESET pulse must happen when these signals are inactive:  $\overline{\text{CS0}}$  or  $\overline{\text{CS1}}$  or  $\overline{\text{CS2}}$  or  $\overline{\text{CS}}$ , and  $\overline{\text{IOW}}$ ,  $\overline{\text{IOR}}$ .

10.1 Timing diagrams

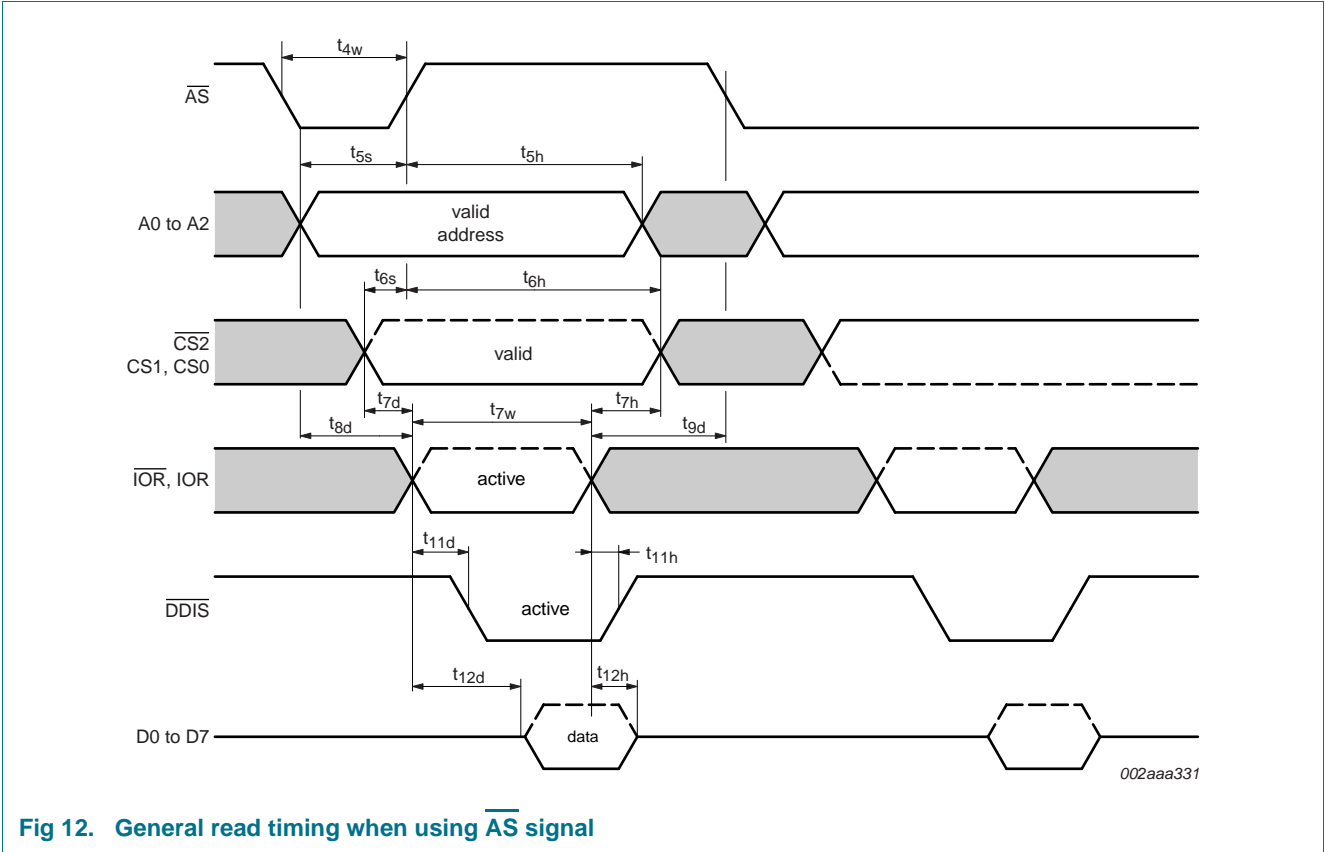

Fig 12. General read timing when using  $\overline{AS}$  signal

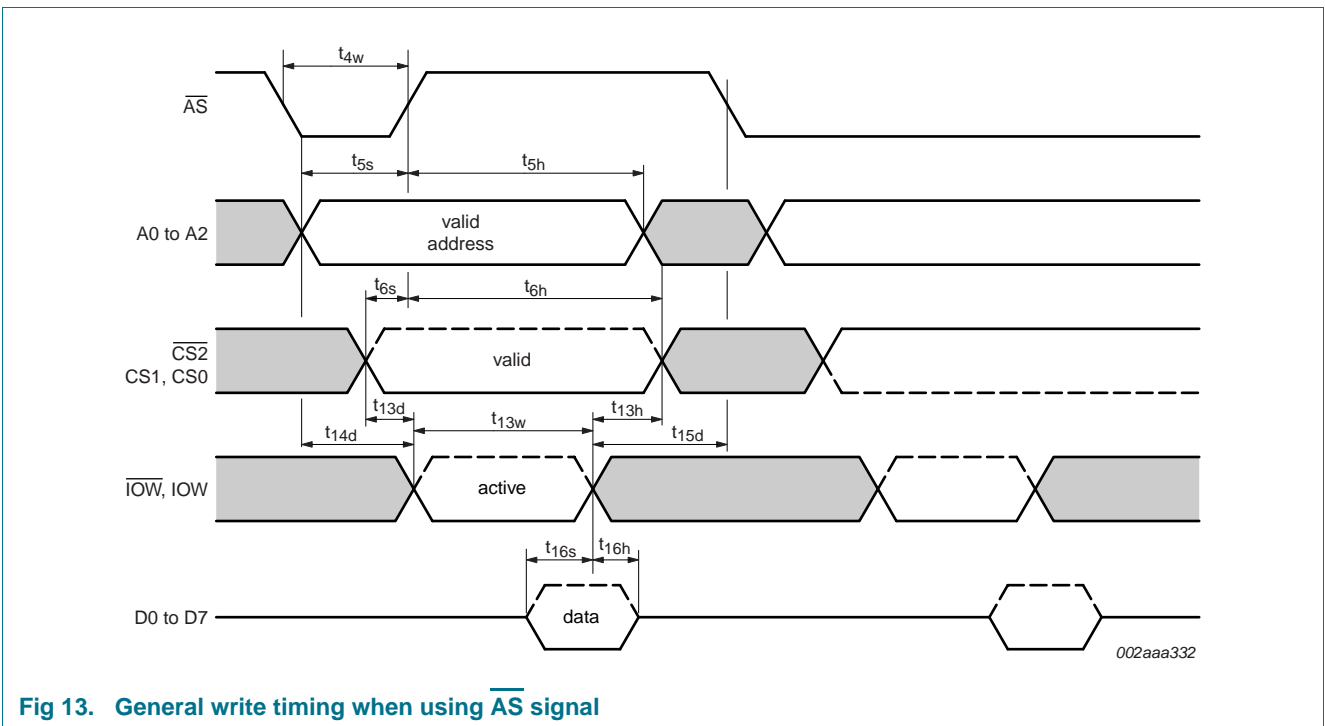

Fig 13. General write timing when using  $\overline{AS}$  signal

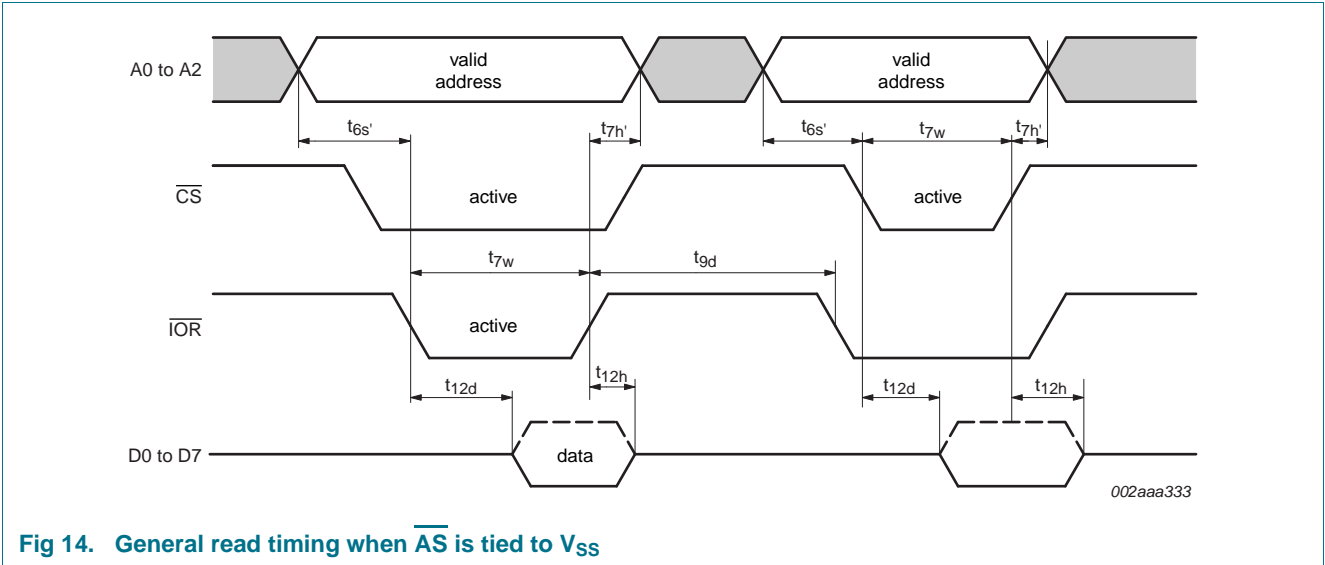

Fig 14. General read timing when  $\overline{AS}$  is tied to  $V_{SS}$

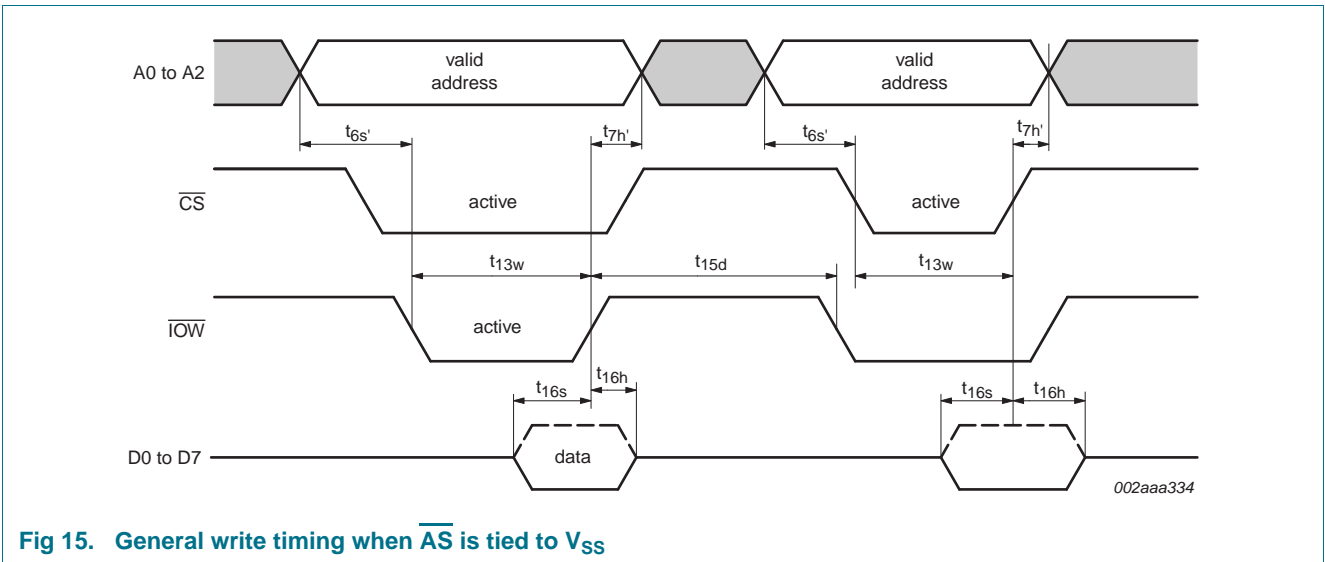

Fig 15. General write timing when  $\overline{AS}$  is tied to  $V_{SS}$

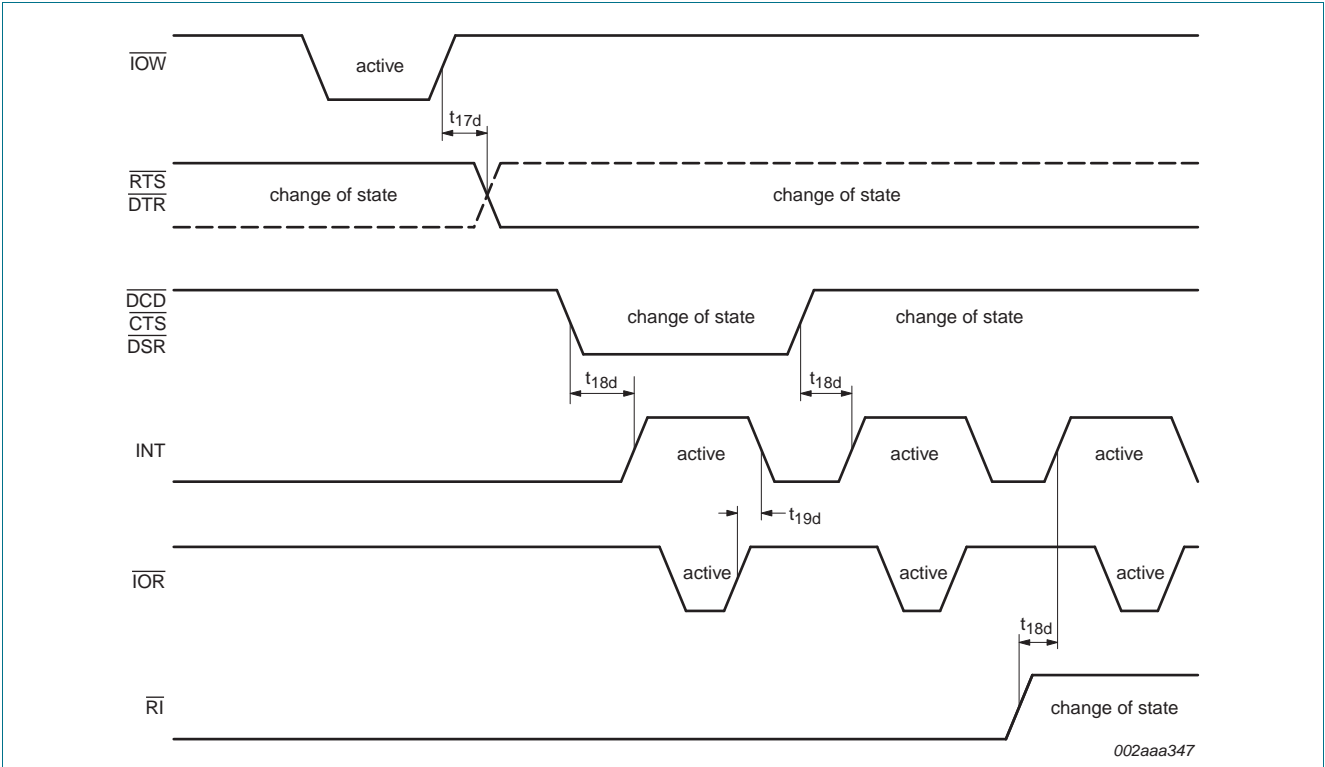

Fig 16. Modem input/output timing

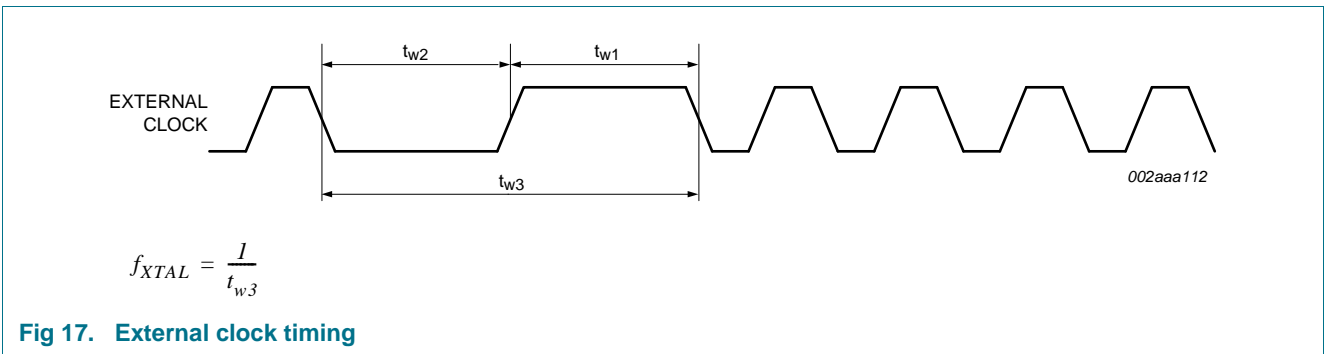

Fig 17. External clock timing

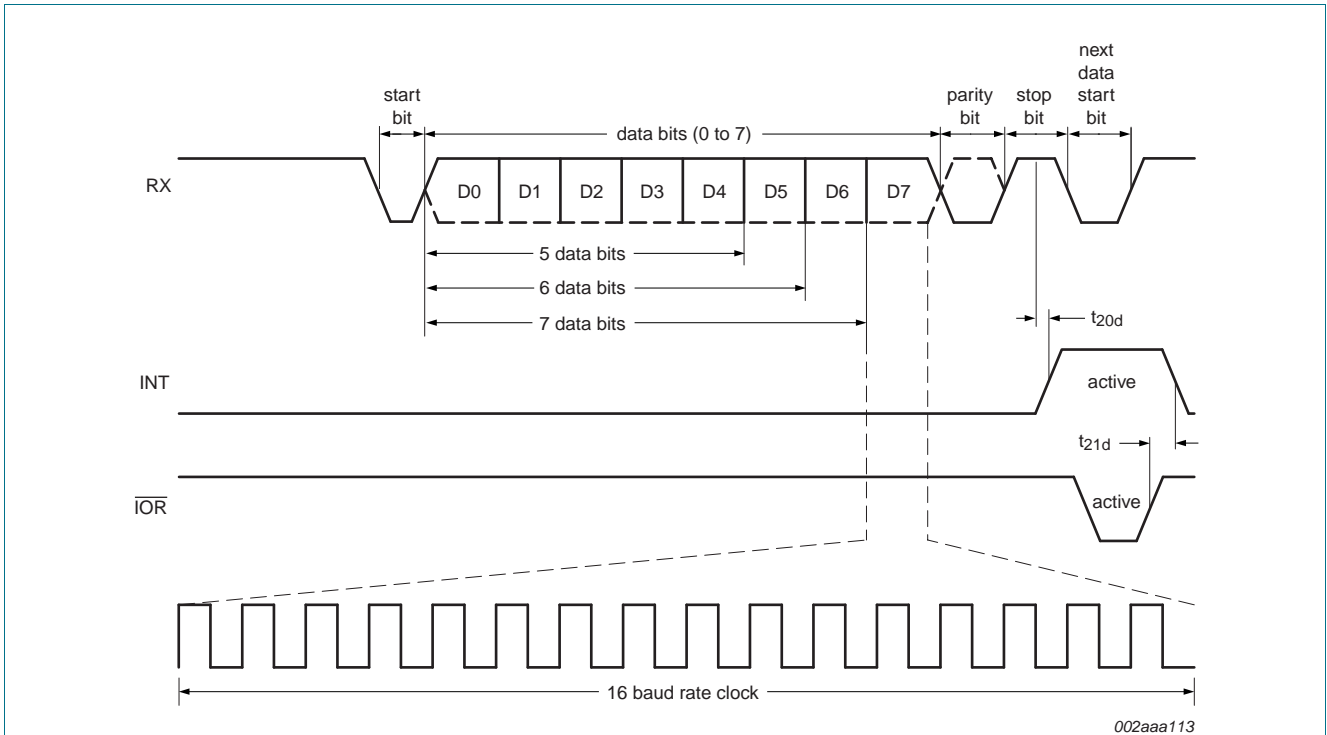

Fig 18. Receive timing

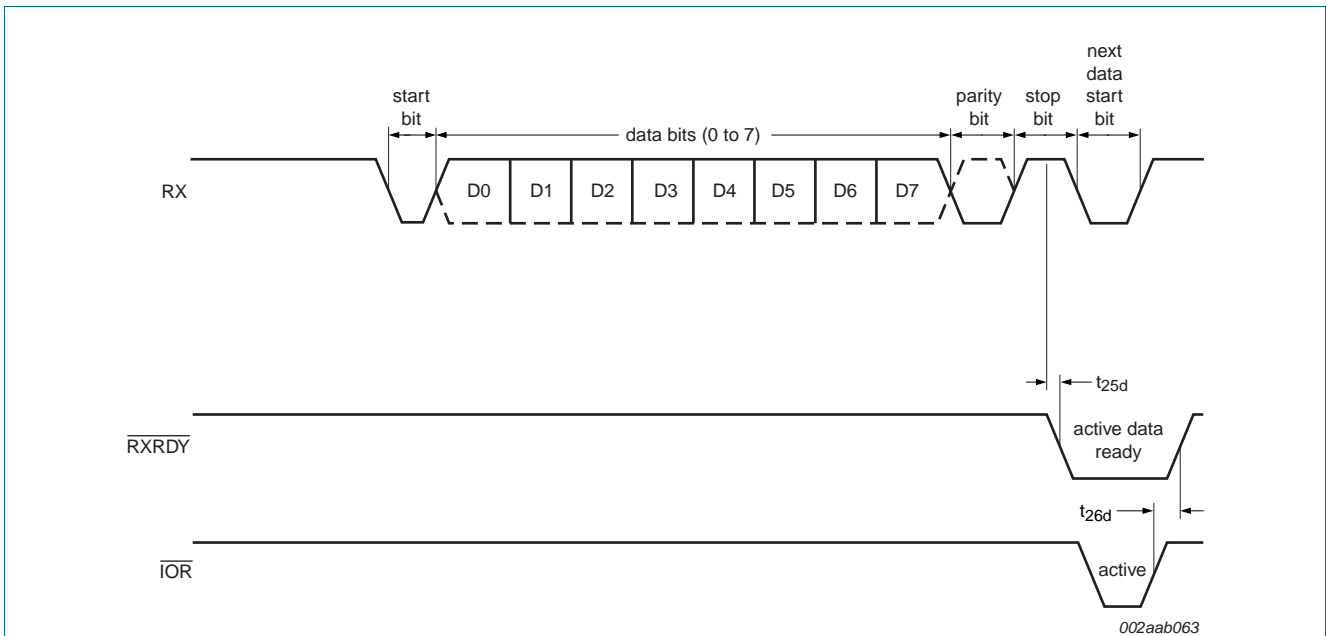

Fig 19. Receive ready timing in non-FIFO mode

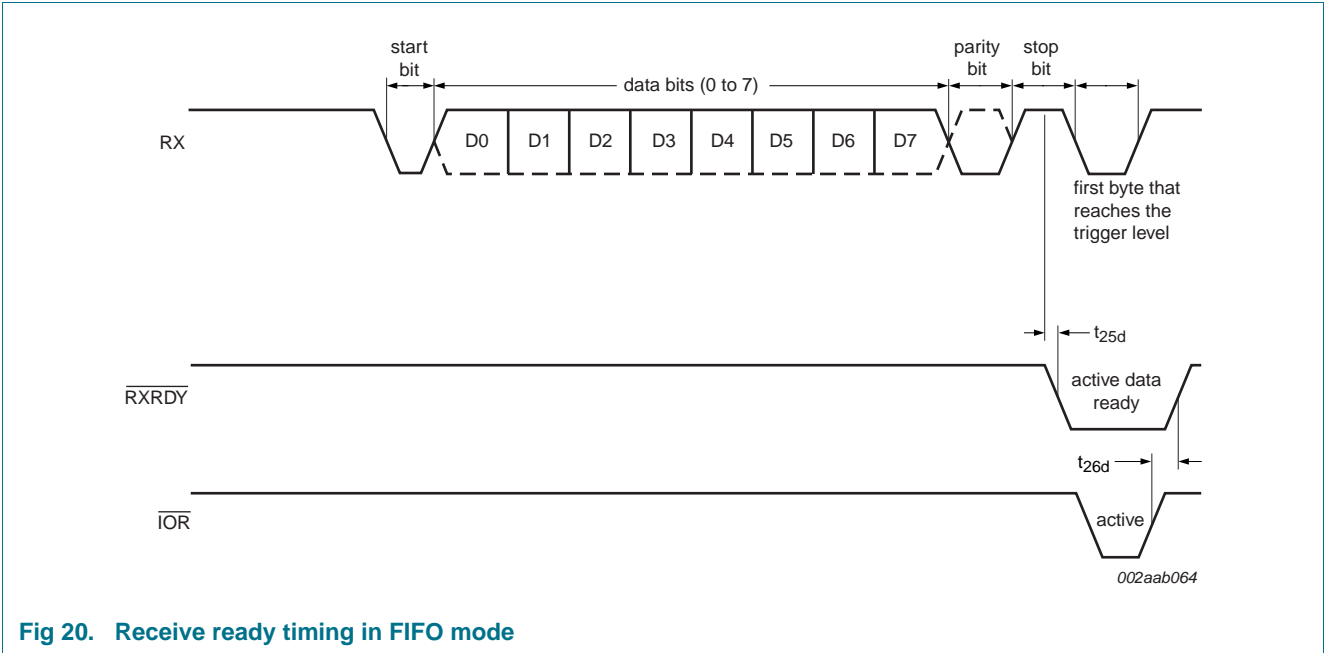

Fig 20. Receive ready timing in FIFO mode

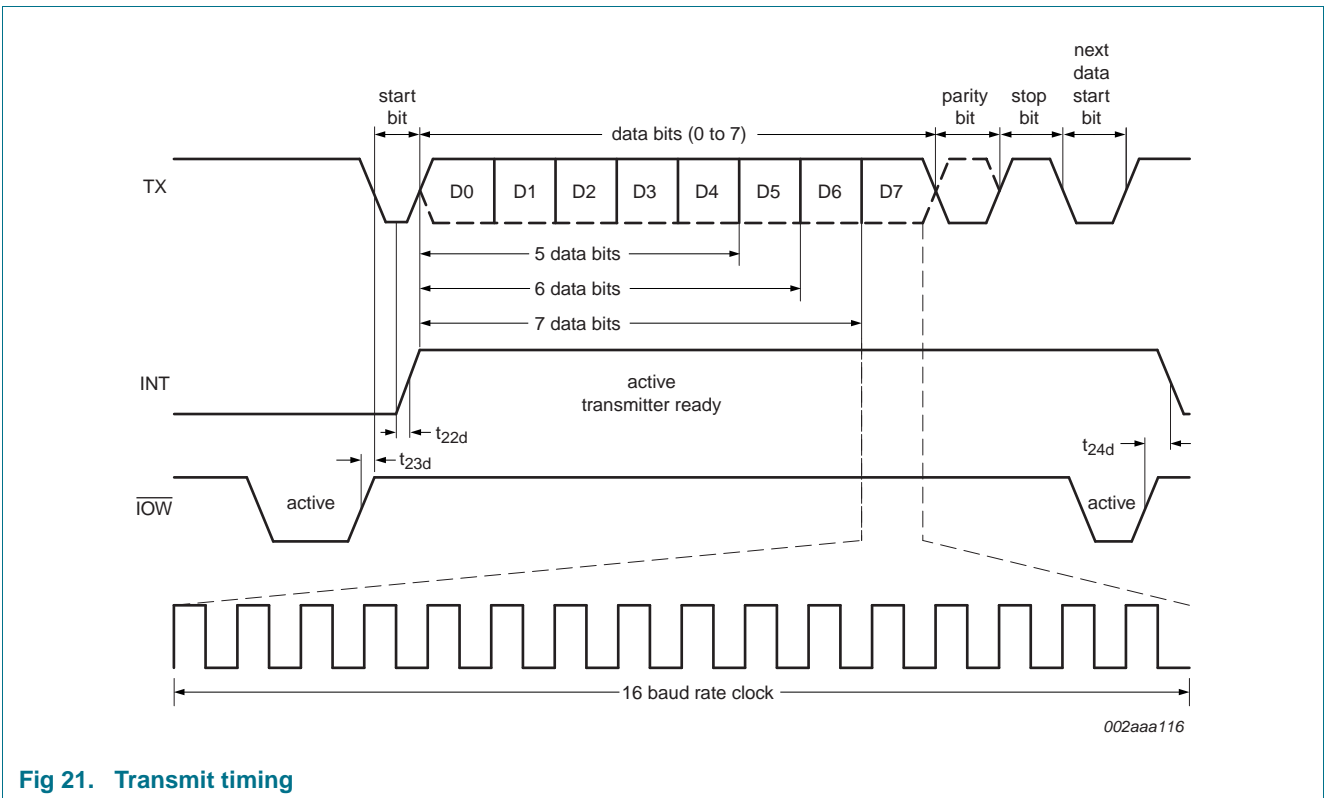

Fig 21. Transmit timing

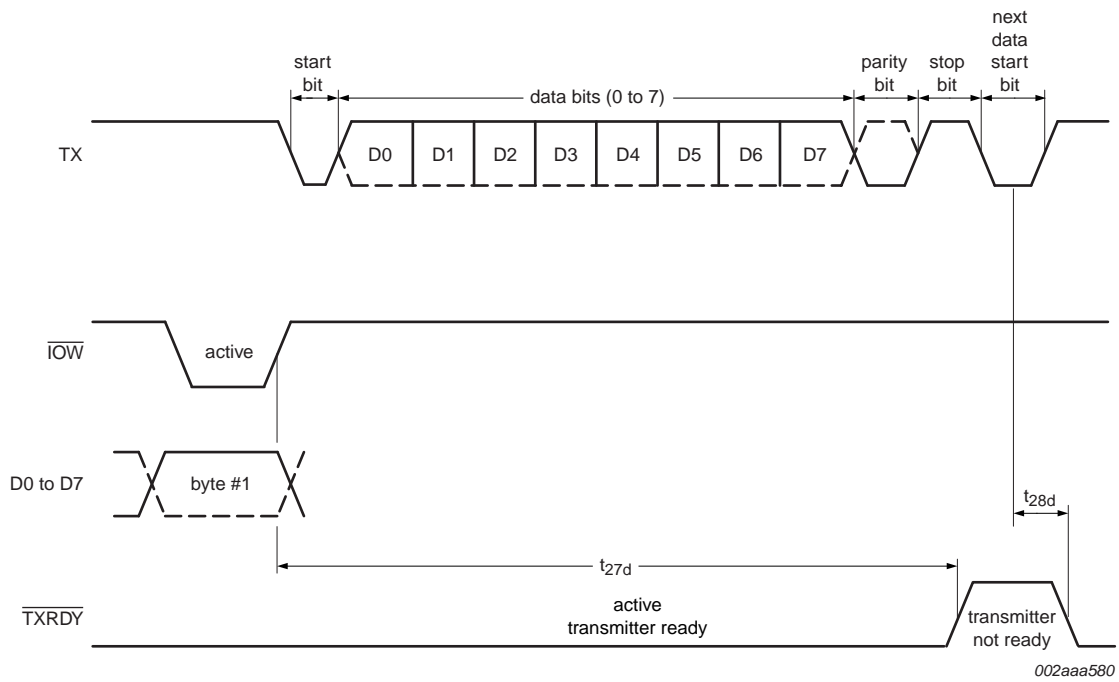

Fig 22. Transmit ready timing in non-FIFO mode

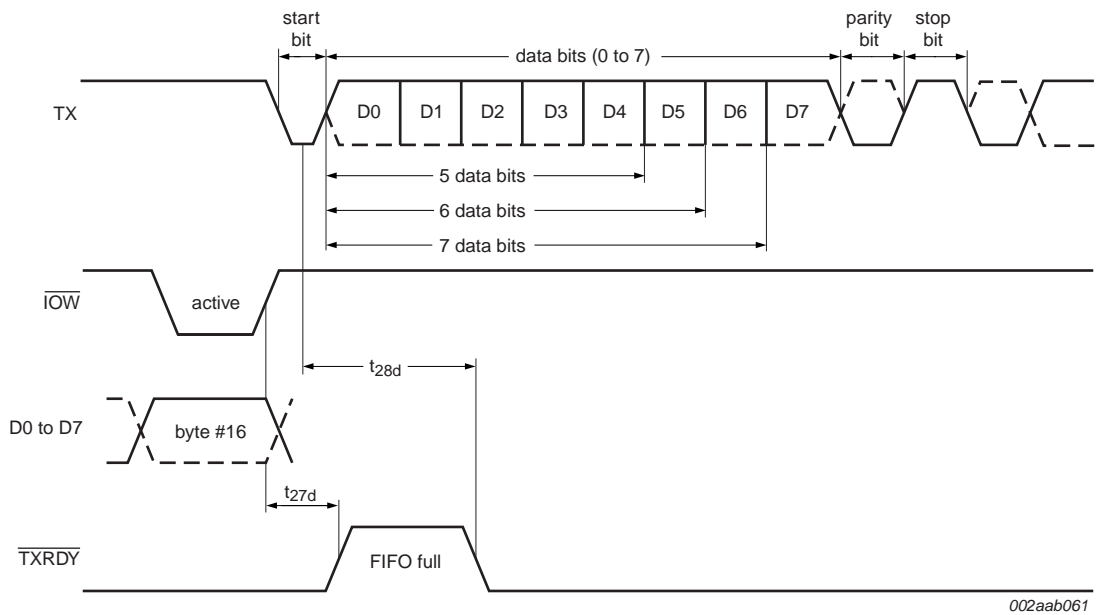

Fig 23. Transmit ready timing in FIFO mode (DMA mode '1')

11. Package outline

DIP40: plastic dual in-line package; 40 leads (600 mil)

SOT129-1

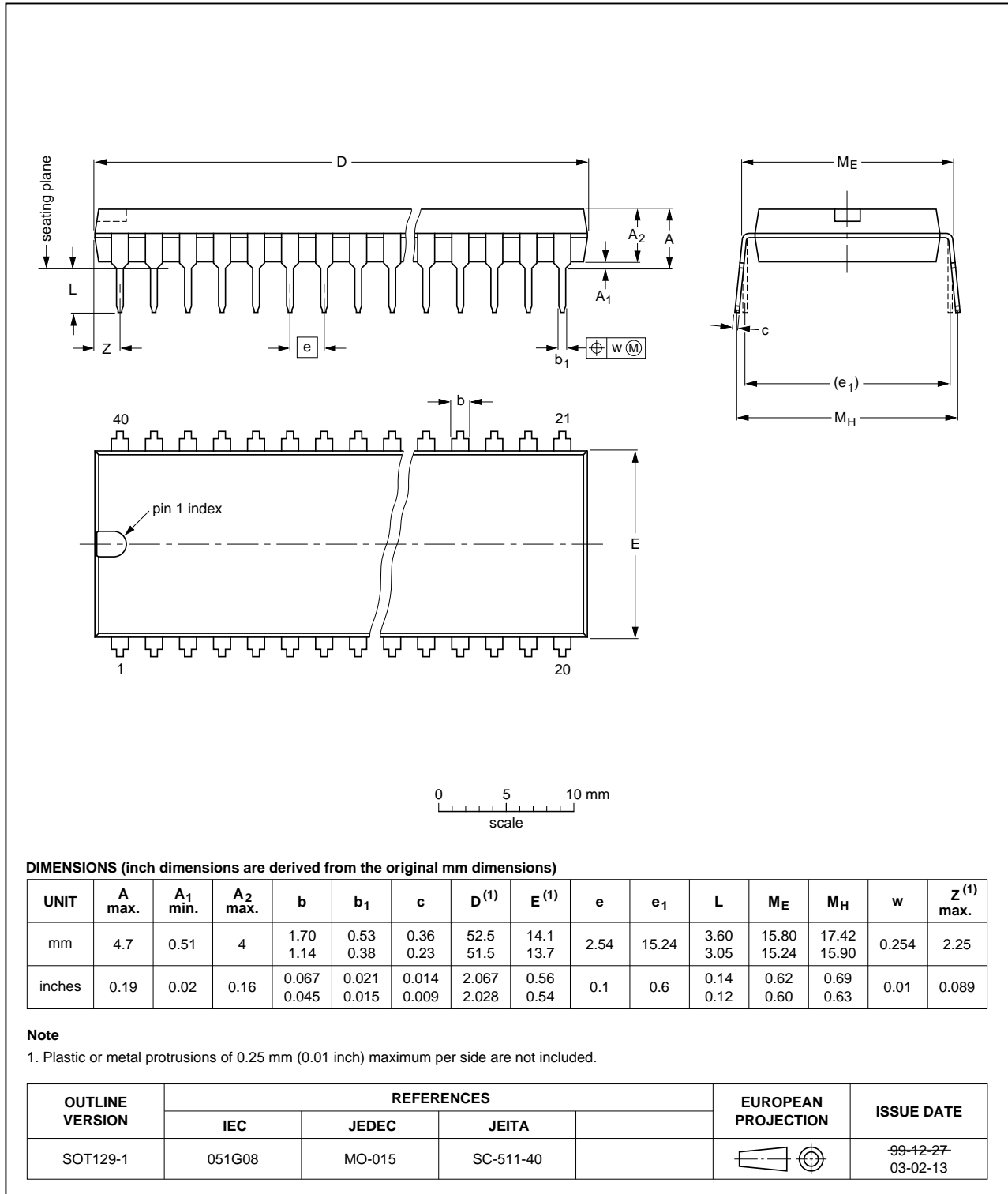

Fig 24. Package outline SOT129-1 (DIP40)

PLCC44: plastic leaded chip carrier; 44 leads

SOT187-2

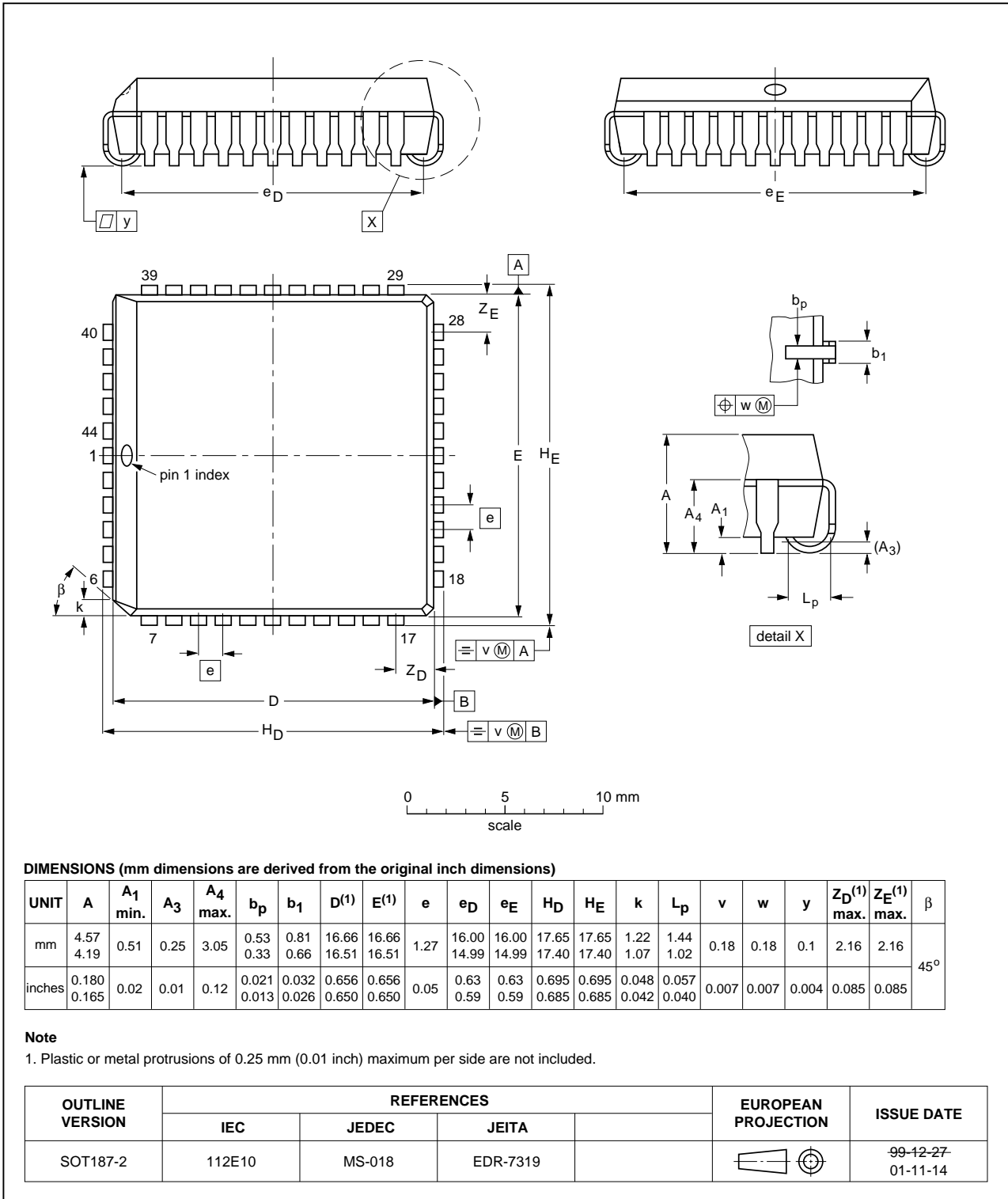

Fig 25. Package outline SOT187-2 (PLCC44)

LQFP48: plastic low profile quad flat package; 48 leads; body 7 x 7 x 1.4 mm

SOT313-2

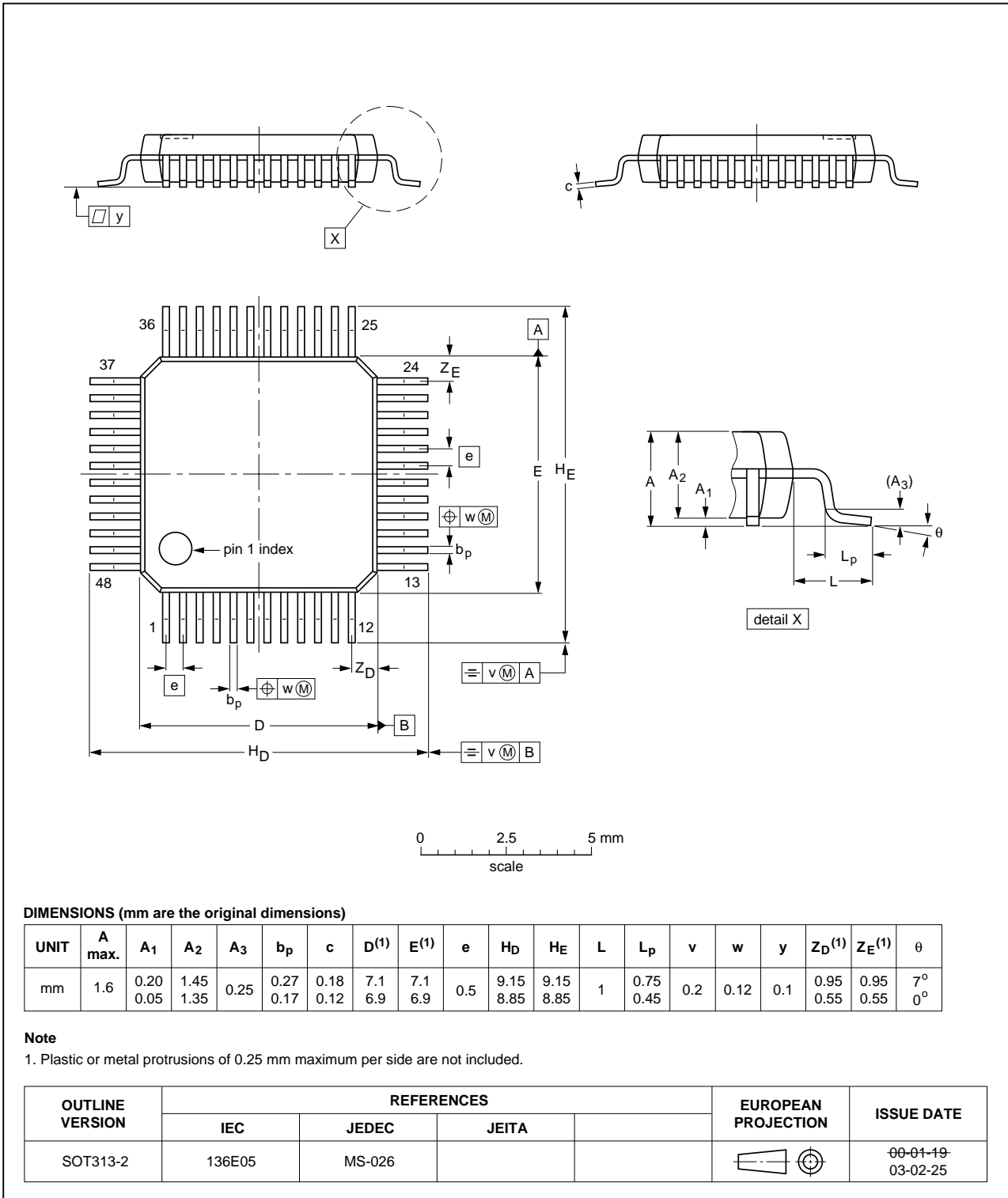

Fig 26. Package outline SOT313-2 (LQFP48)

HVQFN32: plastic thermal enhanced very thin quad flat package; no leads; 32 terminals; body 5 x 5 x 0.85 mm

SOT617-1

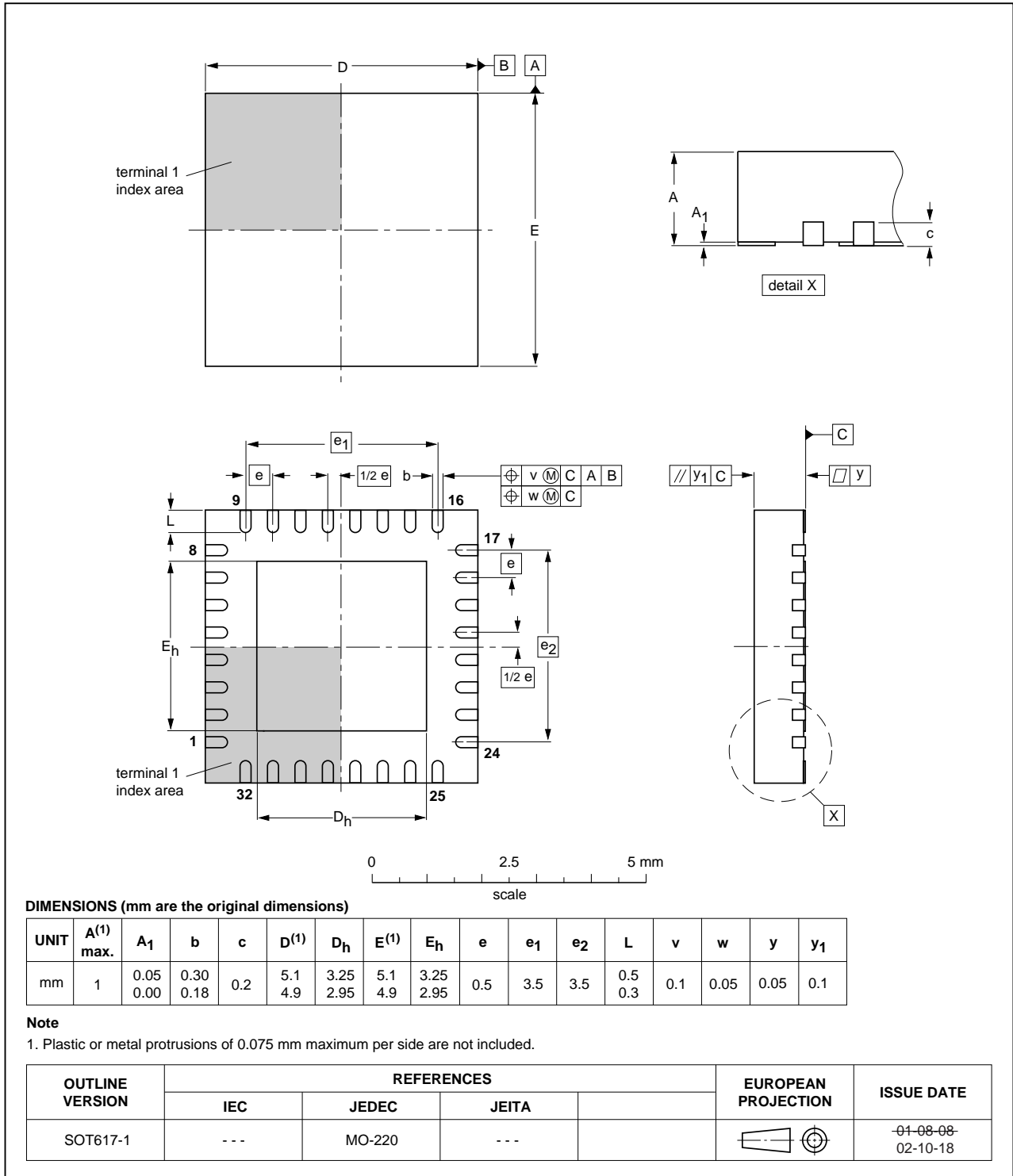

Fig 27. Package outline SOT617-1 (HVQFN32)

## 12. Soldering of SMD packages

This text provides a very brief insight into a complex technology. A more in-depth account of soldering ICs can be found in Application Note *AN10365 "Surface mount reflow soldering description"*.

### 12.1 Introduction to soldering

Soldering is one of the most common methods through which packages are attached to Printed Circuit Boards (PCBs), to form electrical circuits. The soldered joint provides both the mechanical and the electrical connection. There is no single soldering method that is ideal for all IC packages. Wave soldering is often preferred when through-hole and Surface Mount Devices (SMDs) are mixed on one printed wiring board; however, it is not suitable for fine pitch SMDs. Reflow soldering is ideal for the small pitches and high densities that come with increased miniaturization.

### 12.2 Wave and reflow soldering

Wave soldering is a joining technology in which the joints are made by solder coming from a standing wave of liquid solder. The wave soldering process is suitable for the following:

- Through-hole components
- Leaded or leadless SMDs, which are glued to the surface of the printed circuit board

Not all SMDs can be wave soldered. Packages with solder balls, and some leadless packages which have solder lands underneath the body, cannot be wave soldered. Also, leaded SMDs with leads having a pitch smaller than ~0.6 mm cannot be wave soldered, due to an increased probability of bridging.

The reflow soldering process involves applying solder paste to a board, followed by component placement and exposure to a temperature profile. Leaded packages, packages with solder balls, and leadless packages are all reflow solderable.

Key characteristics in both wave and reflow soldering are:

- Board specifications, including the board finish, solder masks and vias
- Package footprints, including solder thieves and orientation
- The moisture sensitivity level of the packages
- Package placement
- Inspection and repair
- Lead-free soldering versus SnPb soldering

### 12.3 Wave soldering

Key characteristics in wave soldering are:

- Process issues, such as application of adhesive and flux, clinching of leads, board transport, the solder wave parameters, and the time during which components are exposed to the wave
- Solder bath specifications, including temperature and impurities

### 12.4 Reflow soldering

Key characteristics in reflow soldering are:

- Lead-free versus SnPb soldering; note that a lead-free reflow process usually leads to higher minimum peak temperatures (see [Figure 28](#)) than a SnPb process, thus reducing the process window
- Solder paste printing issues including smearing, release, and adjusting the process window for a mix of large and small components on one board
- Reflow temperature profile; this profile includes preheat, reflow (in which the board is heated to the peak temperature) and cooling down. It is imperative that the peak temperature is high enough for the solder to make reliable solder joints (a solder paste characteristic). In addition, the peak temperature must be low enough that the packages and/or boards are not damaged. The peak temperature of the package depends on package thickness and volume and is classified in accordance with [Table 27](#) and [28](#)

**Table 27. SnPb eutectic process (from J-STD-020D)**

Package thickness (mm)	Package reflow temperature (°C)	
	Volume (mm <sup>3</sup> )	
	< 350	≥ 350
< 2.5	235	220
≥ 2.5	220	220

**Table 28. Lead-free process (from J-STD-020D)**

Package thickness (mm)	Package reflow temperature (°C)		
	Volume (mm <sup>3</sup> )		
	< 350	350 to 2000	> 2000
< 1.6	260	260	260
1.6 to 2.5	260	250	245
> 2.5	250	245	245

Moisture sensitivity precautions, as indicated on the packing, must be respected at all times.

Studies have shown that small packages reach higher temperatures during reflow soldering, see [Figure 28](#).

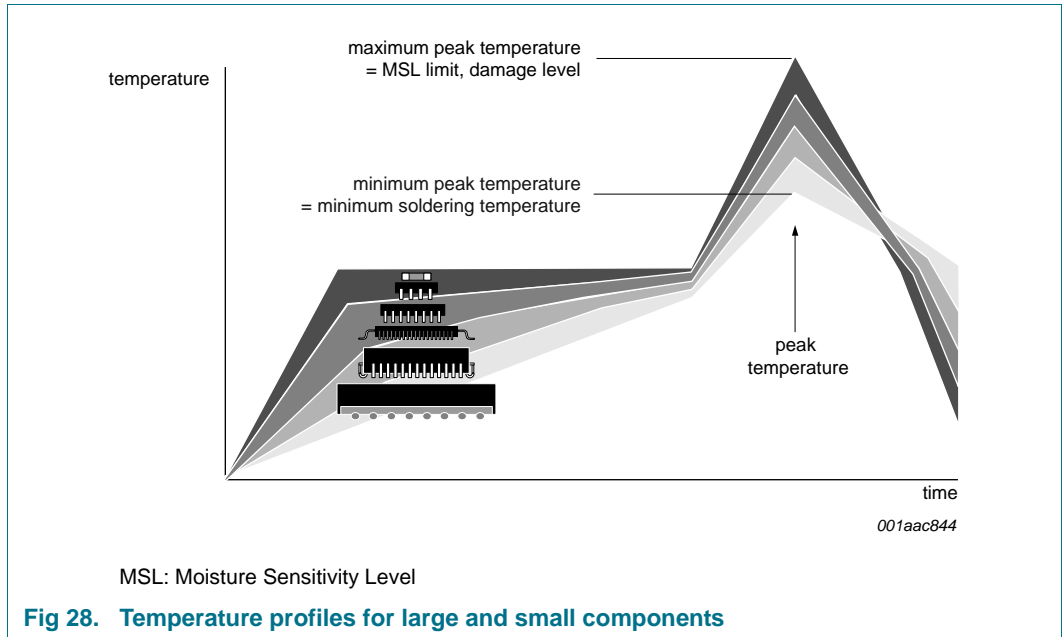

For further information on temperature profiles, refer to Application Note AN10365 “Surface mount reflow soldering description”.

## 13. Soldering of through-hole mount packages

### 13.1 Introduction to soldering through-hole mount packages

This text gives a very brief insight into wave, dip and manual soldering.

Wave soldering is the preferred method for mounting of through-hole mount IC packages on a printed-circuit board.

### 13.2 Soldering by dipping or by solder wave

Driven by legislation and environmental forces the worldwide use of lead-free solder pastes is increasing. Typical dwell time of the leads in the wave ranges from 3 seconds to 4 seconds at 250 °C or 265 °C, depending on solder material applied, SnPb or Pb-free respectively.

The total contact time of successive solder waves must not exceed 5 seconds.

The device may be mounted up to the seating plane, but the temperature of the plastic body must not exceed the specified maximum storage temperature ( $T_{stg(max)}$ ). If the printed-circuit board has been pre-heated, forced cooling may be necessary immediately after soldering to keep the temperature within the permissible limit.

### 13.3 Manual soldering

Apply the soldering iron (24 V or less) to the lead(s) of the package, either below the seating plane or not more than 2 mm above it. If the temperature of the soldering iron bit is less than 300 °C it may remain in contact for up to 10 seconds. If the bit temperature is between 300 °C and 400 °C, contact may be up to 5 seconds.

### 13.4 Package related soldering information

Table 29. Suitability of through-hole mount IC packages for dipping and wave soldering

Package	Soldering method	
	Dipping	Wave
CPGA, HCPGA	-	suitable
DBS, DIP, HDIP, RDBS, SDIP, SIL	suitable	suitable <sup>[1]</sup>
PMFP <sup>[2]</sup>	-	not suitable

[1] For SDIP packages, the longitudinal axis must be parallel to the transport direction of the printed-circuit board.

[2] For PMFP packages hot bar soldering or manual soldering is suitable.

## 14. Abbreviations

Table 30. Abbreviations

Acronym	Description
CMOS	Complementary Metal-Oxide Semiconductor
CPU	Central Processing Unit
DLL	Divisor Latch LSB
DLM	Divisor Latch MSB
DMA	Direct Memory Access
FIFO	First-In, First-Out
ISDN	Integrated Service Digital Network
LSB	Least Significant Bit
MSB	Most Significant Bit
TTL	Transistor-Transistor Logic
UART	Universal Asynchronous Receiver and Transmitter

## 15. Revision history

Table 31. Revision history

Document ID	Release date	Data sheet status	Change notice	Supersedes
SC16C550B_6	20141216	Product data sheet	-	SC16C550B_5
Modifications:	<ul style="list-style-type: none"> <li><a href="#">Table 9 “SC16C550B internal registers”</a>: changed MCR bit 3 from “OUT2” to “OUT2, INT enable”; updated <a href="#">Table note 4</a>.</li> </ul>			
SC16C550B_5	20081001	Product data sheet	-	SC16C550B_4
SC16C550B_4	20070316	Product data sheet	-	SC16C550B_3
SC16C550B_3 (9397 750 14986)	20050620	Product data sheet	-	SC16C550B-02
SC16C550B-02 (9397 750 14446)	20041214	Product data	-	SC16C550B-01
SC16C550B-01 (9397 750 11967)	20040326	Product data	-	-

## 16. Legal information

### 16.1 Data sheet status

Document status <sup>[1][2]</sup>	Product status <sup>[3]</sup>	Definition
Objective [short] data sheet	Development	This document contains data from the objective specification for product development.
Preliminary [short] data sheet	Qualification	This document contains data from the preliminary specification.
Product [short] data sheet	Production	This document contains the product specification.

[1] Please consult the most recently issued document before initiating or completing a design.

[2] The term 'short data sheet' is explained in section "Definitions".

[3] The product status of device(s) described in this document may have changed since this document was published and may differ in case of multiple devices. The latest product status information is available on the Internet at URL <http://www.nxp.com>.

### 16.2 Definitions

**Draft** — The document is a draft version only. The content is still under internal review and subject to formal approval, which may result in modifications or additions. NXP Semiconductors does not give any representations or warranties as to the accuracy or completeness of information included herein and shall have no liability for the consequences of use of such information.

**Short data sheet** — A short data sheet is an extract from a full data sheet with the same product type number(s) and title. A short data sheet is intended for quick reference only and should not be relied upon to contain detailed and full information. For detailed and full information see the relevant full data sheet, which is available on request via the local NXP Semiconductors sales office. In case of any inconsistency or conflict with the short data sheet, the full data sheet shall prevail.

**Product specification** — The information and data provided in a Product data sheet shall define the specification of the product as agreed between NXP Semiconductors and its customer, unless NXP Semiconductors and customer have explicitly agreed otherwise in writing. In no event however, shall an agreement be valid in which the NXP Semiconductors product is deemed to offer functions and qualities beyond those described in the Product data sheet.

### 16.3 Disclaimers

**Limited warranty and liability** — Information in this document is believed to be accurate and reliable. However, NXP Semiconductors does not give any representations or warranties, expressed or implied, as to the accuracy or completeness of such information and shall have no liability for the consequences of use of such information. NXP Semiconductors takes no responsibility for the content in this document if provided by an information source outside of NXP Semiconductors.

In no event shall NXP Semiconductors be liable for any indirect, incidental, punitive, special or consequential damages (including - without limitation - lost profits, lost savings, business interruption, costs related to the removal or replacement of any products or rework charges) whether or not such damages are based on tort (including negligence), warranty, breach of contract or any other legal theory.

Notwithstanding any damages that customer might incur for any reason whatsoever, NXP Semiconductors' aggregate and cumulative liability towards customer for the products described herein shall be limited in accordance with the *Terms and conditions of commercial sale* of NXP Semiconductors.

**Right to make changes** — NXP Semiconductors reserves the right to make changes to information published in this document, including without limitation specifications and product descriptions, at any time and without notice. This document supersedes and replaces all information supplied prior to the publication hereof.

**Suitability for use** — NXP Semiconductors products are not designed, authorized or warranted to be suitable for use in life support, life-critical or safety-critical systems or equipment, nor in applications where failure or malfunction of an NXP Semiconductors product can reasonably be expected to result in personal injury, death or severe property or environmental damage. NXP Semiconductors and its suppliers accept no liability for inclusion and/or use of NXP Semiconductors products in such equipment or applications and therefore such inclusion and/or use is at the customer's own risk.

**Applications** — Applications that are described herein for any of these products are for illustrative purposes only. NXP Semiconductors makes no representation or warranty that such applications will be suitable for the specified use without further testing or modification.

Customers are responsible for the design and operation of their applications and products using NXP Semiconductors products, and NXP Semiconductors accepts no liability for any assistance with applications or customer product design. It is customer's sole responsibility to determine whether the NXP Semiconductors product is suitable and fit for the customer's applications and products planned, as well as for the planned application and use of customer's third party customer(s). Customers should provide appropriate design and operating safeguards to minimize the risks associated with their applications and products.

NXP Semiconductors does not accept any liability related to any default, damage, costs or problem which is based on any weakness or default in the customer's applications or products, or the application or use by customer's third party customer(s). Customer is responsible for doing all necessary testing for the customer's applications and products using NXP Semiconductors products in order to avoid a default of the applications and the products or of the application or use by customer's third party customer(s). NXP does not accept any liability in this respect.

**Limiting values** — Stress above one or more limiting values (as defined in the Absolute Maximum Ratings System of IEC 60134) will cause permanent damage to the device. Limiting values are stress ratings only and (proper) operation of the device at these or any other conditions above those given in the Recommended operating conditions section (if present) or the Characteristics sections of this document is not warranted. Constant or repeated exposure to limiting values will permanently and irreversibly affect the quality and reliability of the device.

**Terms and conditions of commercial sale** — NXP Semiconductors products are sold subject to the general terms and conditions of commercial sale, as published at <http://www.nxp.com/profile/terms>, unless otherwise agreed in a valid written individual agreement. In case an individual agreement is concluded only the terms and conditions of the respective agreement shall apply. NXP Semiconductors hereby expressly objects to applying the customer's general terms and conditions with regard to the purchase of NXP Semiconductors products by customer.

**No offer to sell or license** — Nothing in this document may be interpreted or construed as an offer to sell products that is open for acceptance or the grant, conveyance or implication of any license under any copyrights, patents or other industrial or intellectual property rights.

**Export control** — This document as well as the item(s) described herein may be subject to export control regulations. Export might require a prior authorization from competent authorities.

**Non-automotive qualified products** — Unless this data sheet expressly states that this specific NXP Semiconductors product is automotive qualified, the product is not suitable for automotive use. It is neither qualified nor tested in accordance with automotive testing or application requirements. NXP Semiconductors accepts no liability for inclusion and/or use of non-automotive qualified products in automotive equipment or applications.

In the event that customer uses the product for design-in and use in automotive applications to automotive specifications and standards, customer (a) shall use the product without NXP Semiconductors' warranty of the product for such automotive applications, use and specifications, and (b) whenever customer uses the product for automotive applications beyond

NXP Semiconductors' specifications such use shall be solely at customer's own risk, and (c) customer fully indemnifies NXP Semiconductors for any liability, damages or failed product claims resulting from customer design and use of the product for automotive applications beyond NXP Semiconductors' standard warranty and NXP Semiconductors' product specifications.

**Translations** — A non-English (translated) version of a document is for reference only. The English version shall prevail in case of any discrepancy between the translated and English versions.

## 16.4 Trademarks

Notice: All referenced brands, product names, service names and trademarks are the property of their respective owners.

## 17. Contact information

For more information, please visit: <http://www.nxp.com>

For sales office addresses, please send an email to: [salesaddresses@nxp.com](mailto:salesaddresses@nxp.com)

## 18. Contents

<b>1</b>	<b>General description</b> . . . . .	<b>1</b>	12.2	Wave and reflow soldering . . . . .	42
<b>2</b>	<b>Features and benefits</b> . . . . .	<b>1</b>	12.3	Wave soldering . . . . .	42
<b>3</b>	<b>Ordering information</b> . . . . .	<b>2</b>	12.4	Reflow soldering . . . . .	43
<b>4</b>	<b>Block diagram</b> . . . . .	<b>3</b>	<b>13</b>	<b>Soldering of through-hole mount packages</b> . . . . .	<b>44</b>
<b>5</b>	<b>Pinning information</b> . . . . .	<b>4</b>	13.1	Introduction to soldering through-hole mount packages . . . . .	44
5.1	Pinning . . . . .	4	13.2	Soldering by dipping or by solder wave . . . . .	44
5.2	Pin description . . . . .	6	13.3	Manual soldering . . . . .	44
<b>6</b>	<b>Functional description</b> . . . . .	<b>9</b>	13.4	Package related soldering information . . . . .	45
6.1	Internal registers . . . . .	10	<b>14</b>	<b>Abbreviations</b> . . . . .	<b>45</b>
6.2	FIFO operation . . . . .	10	<b>15</b>	<b>Revision history</b> . . . . .	<b>46</b>
6.3	Autoflow control . . . . .	11	<b>16</b>	<b>Legal information</b> . . . . .	<b>47</b>
6.3.1	Auto-RTS . . . . .	11	16.1	Data sheet status . . . . .	47
6.3.2	Auto-CTS . . . . .	11	16.2	Definitions . . . . .	47
6.3.3	Enabling autoflow control and auto-CTS . . . . .	12	16.3	Disclaimers . . . . .	47
6.3.4	Auto-CTS and auto-RTS functional timing . . . . .	12	16.4	Trademarks . . . . .	48
6.4	Hardware/software and time-out interrupts . . . . .	13	<b>17</b>	<b>Contact information</b> . . . . .	<b>48</b>
6.5	Programmable baud rate generator . . . . .	14	<b>18</b>	<b>Contents</b> . . . . .	<b>49</b>
6.6	DMA operation . . . . .	15			
6.7	Loopback mode . . . . .	16			
<b>7</b>	<b>Register descriptions</b> . . . . .	<b>18</b>			
7.1	Transmit Holding Register (THR) and Receive Holding Register (RHR) . . . . .	19			
7.2	Interrupt Enable Register (IER) . . . . .	19			
7.2.1	IER versus Receive FIFO interrupt mode operation . . . . .	20			
7.2.2	IER versus Receive/Transmit FIFO polled mode operation . . . . .	20			
7.3	FIFO Control Register (FCR) . . . . .	20			
7.3.1	DMA mode . . . . .	20			
7.3.1.1	Mode 0 (FCR bit 3 = 0) . . . . .	20			
7.3.1.2	Mode 1 (FCR bit 3 = 1) . . . . .	20			
7.3.2	FIFO mode . . . . .	21			
7.4	Interrupt Status Register (ISR) . . . . .	22			
7.5	Line Control Register (LCR) . . . . .	23			
7.6	Modem Control Register (MCR) . . . . .	25			
7.7	Line Status Register (LSR) . . . . .	26			
7.8	Modem Status Register (MSR) . . . . .	27			
7.9	Scratchpad Register (SPR) . . . . .	28			
7.10	SC16C550B external reset conditions . . . . .	28			
<b>8</b>	<b>Limiting values</b> . . . . .	<b>28</b>			
<b>9</b>	<b>Static characteristics</b> . . . . .	<b>29</b>			
<b>10</b>	<b>Dynamic characteristics</b> . . . . .	<b>30</b>			
10.1	Timing diagrams . . . . .	32			
<b>11</b>	<b>Package outline</b> . . . . .	<b>38</b>			
<b>12</b>	<b>Soldering of SMD packages</b> . . . . .	<b>42</b>			
12.1	Introduction to soldering . . . . .	42			

Please be aware that important notices concerning this document and the product(s) described herein, have been included in section 'Legal information'.

© NXP Semiconductors N.V. 2014.

All rights reserved.

For more information, please visit: <http://www.nxp.com>



For sales office addresses, please send an email to: [salesaddresses@nxp.com](mailto:salesaddresses@nxp.com)

Date of release: 16 December 2014

Document identifier: SC16C550B

## Looking for pricing, stock, or lifecycle information?

Click below to explore more details on WIN SOURCE:

-  [View SC16C550BIA44,512 on WIN SOURCE](#)
-  [NXP / Nexperia Information](#)

## Optimize Your Supply Chain with WIN SOURCE Solutions

-  Global Sourcing Solution
-  Obsolete Management
-  Cost Control Management
-  Shortage Management
-  Alternative Solution
-  Excess Inventory Management