



**THE DATASHEET OF  
SI2435-A-FT**





## V.34, V.17 FAX ISOMODEM<sup>®</sup> WITH GLOBAL DAA

### Features

- Fax modem formats
  - V.29, V.27ter, V.17, V.21 channel 2
  - V.34 half duplex
  - Automatic rate negotiation
- Supports type I and II caller ID
- No external ROM or RAM required
- Distinctive ring detection
- UART or parallel interface
- Lead-free/RoHS-compliant packages available
- Integrated DAA
  - Over 6000 V capacitive isolation
  - Parallel phone detect
  - Globally-compliant line interface
  - Overcurrent detection
- Firmware upgradeable
- DTMF detection/generation
- Data/Fax discriminator
- Class1 AT command set

### Applications

- Fax machines
- Fax telephones
- Multifunctional printers
- Fax server

### Description

The Si2435 and Si2417 are complete two-chip fax modems ranging in speed from 33,600 bps to 14,400 bps. The ISOModem chipsets utilize Silicon Laboratories' third-generation direct access arrangement (DAA) to provide a globally-programmable telephone line interface with an unparalleled level of integration. Available in two small packages, the compact solutions eliminate the need for a separate DSP, modem controller, codec, isolation transformer, relay, opto-isolators, and 2–4 wire hybrid. The ISOModem provides conventional fax formats with connect rates of up to 33,600 bps over the Public Switched Telephone Network (PSTN). The Si2435 and Si2417 are ideal for fax modem applications due to their global compliance, small footprint, and minimal external component count.

### Functional Block Diagram

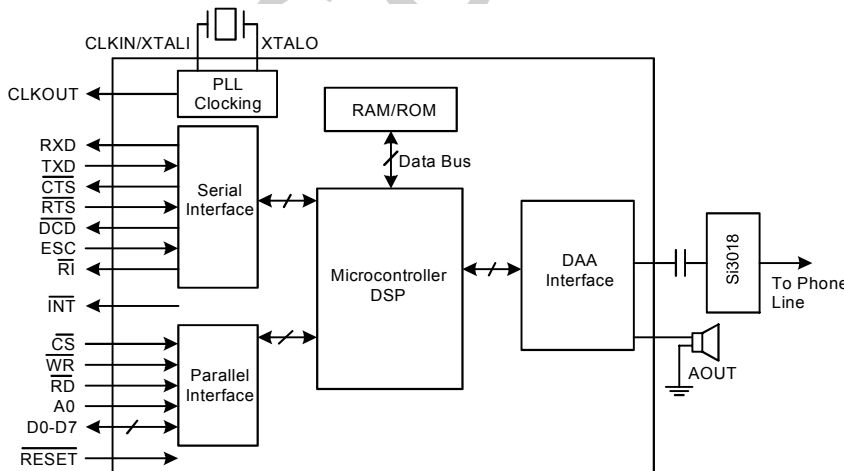
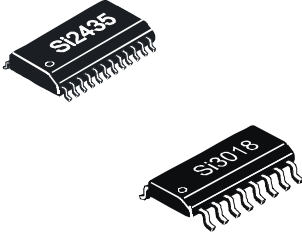
**Ordering Information**

This data sheet is valid only for those chipset combinations listed on page 61.

**Pin Assignments**

Si2435/17	
CLKIN/XTALI	1
XTALO	2
CLKOUT/A0	3
FSYNC/D6	4
VD3.3	5
GND	6
VDA	7
RTS/D7	8
RXD/RD	9
TXD/WR	10
CTS/CS	11
RESET	12
24	SDO/D5
23	DCD/D4
22	ESC/D3
21	VD3.3
20	GND
19	VDB
18	SDI/D2
17	RI/D1
16	INT/DO
15	AOUT/INT
14	C1A
13	C2A

Si3018	
QE	1
DCT	2
RX	3
IB	4
C1B	5
C2B	6
VREG	7
RNG1	8
16	DCT2
15	IGND
14	DCT3
13	QB
12	QE2
11	SC
10	VREG2
9	RNG2

U.S. Patent #5,870,046  
 U.S. Patent #6,061,009  
 Other patents pending

Confidential

---

**TABLE OF CONTENTS**

---

<b><u>Section</u></b>	<b><u>Page</u></b>
<b>1. Electrical Specifications</b> .....	<b>4</b>
<b>2. Typical Application Schematic</b> .....	<b>10</b>
<b>3. Bill of Materials: Si2435/17 Chipset</b> .....	<b>11</b>
<b>4. Functional Description</b> .....	<b>14</b>
4.1. Digital Interface .....	14
4.2. Serial Interface .....	14
4.3. Parallel Interface .....	14
4.4. Command State .....	14
4.5. Data State .....	14
4.6. Data Mode (+FCLASS = 0) .....	15
4.7. Fax Mode (+FCLASS = 1) .....	15
4.8. Voice Mode (+FCLASS = 8) .....	15
4.9. V.8 Call Establishment (Si2435 Only) .....	15
4.10. Data / Fax / Voice Discriminator .....	15
4.11. DTMF Detection / Generation .....	15
4.12. Caller ID Operation .....	15
4.13. Parallel Phone Detection .....	15
4.14. Overcurrent Detection .....	16
4.15. Global Operation .....	16
4.16. Clocking .....	16
4.17. Low-Power Modes .....	16
4.18. Firmware Upgrades .....	17
4.19. Codec Interface .....	17
4.20. AT Commands .....	17
<b>5. S-Registers</b> .....	<b>32</b>
<b>6. User-Access Registers (U-Registers)</b> .....	<b>35</b>
6.1. Bit-Mapped U-Register Detail (defaults in bold) .....	41
<b>7. Parallel Interface Registers</b> .....	<b>56</b>
<b>8. Pin Descriptions: Si2435/17</b> .....	<b>58</b>
<b>9. Pin Descriptions: Si3018</b> .....	<b>60</b>
<b>10. Ordering Guide</b> .....	<b>61</b>
<b>11. Package Outline: 24-Pin TSSOP</b> .....	<b>62</b>
<b>12. Package Outline: 16-Pin SOIC</b> .....	<b>63</b>
<b>Contact Information</b> .....	<b>64</b>

# Si2435/Si2417

## 1. Electrical Specifications

**Table 1. Recommended Operating Conditions**

Parameter <sup>1</sup>	Symbol	Test Condition	Min <sup>2</sup>	Typ	Max <sup>2</sup>	Unit
Ambient Temperature	T <sub>A</sub>	F-Grade	0	25	70	°C
Si2435/17 Supply Voltage, Digital <sup>3</sup>	V <sub>D</sub>		3.0	3.3	3.6	V

**Notes:**

- The Si2435/17 specifications are guaranteed when the typical application circuit (including component tolerance) and any Si2435/17 and any Si3018 are used. See "2. Typical Application Schematic" on page 10.
- All minimum and maximum specifications are guaranteed and apply across the recommended operating conditions. Typical values apply at nominal supply voltages and an operating temperature of 25 °C unless otherwise stated.
- The digital supply, V<sub>D</sub>, operates from 3.0 to 3.6 V. The Si2435/17 interface supports 5 V logic (CLKIN/XTALI supports 3.3 V logic only).

**Table 2. Loop Characteristics**

(V<sub>D</sub> = 3.0 to 3.6 V, T<sub>A</sub> = 0 to 70 °C for F-Grade)

Parameter	Symbol	Test Condition	Min	Typ	Max	Unit
DC Termination Voltage	V <sub>TR</sub>	I <sub>L</sub> = 20 mA, ILIM <sup>1</sup> = 0 DCV = 00, MINI = 11, DCR = 0	—	—	6.0	V
DC Termination Voltage	V <sub>TR</sub>	I <sub>L</sub> = 120 mA, ILIM = 0 DCV = 00, MINI = 11, DCR = 0	9	—	—	V
DC Termination Voltage	V <sub>TR</sub>	I <sub>L</sub> = 20 mA, ILIM = 0 DCV = 11, MINI = 00, DCR = 0	—	—	7.5	V
DC Termination Voltage	V <sub>TR</sub>	I <sub>L</sub> = 120 mA, ILIM = 0 DCV = 11, MINI = 00, DCR = 0	9	—	—	V
DC Termination Voltage	V <sub>TR</sub>	I <sub>L</sub> = 20 mA, ILIM = 1 DCV = 11, MINI = 00, DCR = 0	—	—	7.5	V
DC Termination Voltage	V <sub>TR</sub>	I <sub>L</sub> = 60 mA, ILIM = 1 DCV = 11, MINI = 00, DCR = 0	40	—	—	V
DC Termination Voltage	V <sub>TR</sub>	I <sub>L</sub> = 50 mA, ILIM = 1 DCV = 11, MINI = 00, DCR = 0	—	—	40	V
On-Hook Leakage Current	I <sub>LK</sub>	V <sub>TR</sub> = -48 V	—	—	5	μA
Operating Loop Current	I <sub>LP</sub>	MINI = 00, ILIM = 0	10	—	120	mA
Operating Loop Current	I <sub>LP</sub>	MINI = 00, ILIM = 1	10	—	60	mA
DC Ring Current		DC current flowing through ring detection circuitry	—	1.5	3	μA
Ring Detect Voltage <sup>2</sup>	V <sub>RD</sub>	RT = 0	12	15	18	V <sub>RMS</sub>
Ring Detect Voltage <sup>2</sup>	V <sub>RD</sub>	RT = 1	18	21	25	V <sub>RMS</sub>
Ring Frequency	F <sub>R</sub>		15	—	68	Hz
Ringer Equivalence Number	REN		—	—	0.2	

**Notes:**

- ILIM = U67, bit 9; DCV = U67, bits 3:2; MINI = U67, bits 13:12; DCR = U67, bit 7; RT = U67, bit 0.
- The ring signal is guaranteed to not be detected below the minimum. The ring signal is guaranteed to be detected above the maximum.

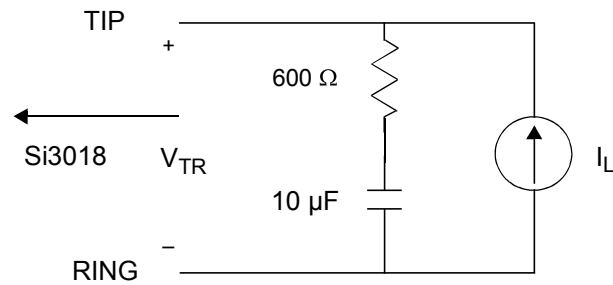

Figure 1. Test Circuit for Loop Characteristics

Table 3. DC Characteristics,  $V_D = 3.0$  to  $3.6$  V( $V_D = 3.0$  to  $3.6$  V,  $T_A = 0$  to  $70$  °C for F-Grade)

Parameter	Symbol	Test Condition	Min	Typ	Max	Unit
High Level Input Voltage	$V_{IH}$		2.0	—	—	V
Low Level Input Voltage	$V_{IL}$		—	—	0.8	V
High Level Output Voltage	$V_{OH}$	$I_O = -2$ mA	2.4	—	—	V
Low Level Output Voltage	$V_{OL}$	$I_O = 2$ mA	—	—	0.35	V
Input Leakage Current	$I_L$		-10	—	10	μA
Pullup Resistance Pins 3, 4, 9, 11, 15, 16, 17, 18, 23, 24	$R_{PU}$		50	125	200	kΩ
Total Supply Current*	$I_D$	$V_{D3.3}$ pin	—	26	35	mA
Total Supply Current, Wake-on-Ring*	$I_D$		—	6	—	mA
Total Supply Current, Powerdown*	$I_D$	PDN = 1	—	80	—	μA

\*Note: All inputs at 0 or  $V_D$ . All inputs held static except clock and all outputs unloaded (Static  $I_{OUT} = 0$  mA).

# Si2435/Si2417

**Table 4. AC Characteristics**

( $V_D = 3.0$  to  $3.6$  V,  $T_A = 0$  to  $70$  °C for F-Grade,  $F_s = 8$  kHz)

Parameter	Symbol	Test Condition	Min	Typ	Max	Unit
Clock Input Frequency	$F_{XTL}$	default	—	4.9152	—	MHz
Clock Input Frequency	$F_{XTL}$	$\leq 10$ k $\Omega$ resistor between pin 23 and GND	—	27	—	MHz
Receive Frequency Response		Low -3 dBFS Corner, FILT = 0	—	5	—	Hz
Receive Frequency Response		Low -3 dBFS Corner, FILT = 1	—	200	—	Hz
Transmit Full Scale Level <sup>1</sup>	$V_{FS}$		—	1.1	—	$V_{PEAK}$
Receive Full Scale Level <sup>1,2</sup>	$V_{FS}$		—	1.1	—	$V_{PEAK}$
Dynamic Range <sup>3</sup>	DR	ILIM = 0, DCV = 11, MINI = 00 DCR = 0, $I_L = 100$ mA	—	80	—	dB
Dynamic Range <sup>3</sup>	DR	ILIM = 0, DCV = 00, MINI = 11 DCR = 0, $I_L = 20$ mA	—	80	—	dB
Dynamic Range <sup>3</sup>	DR	ILIM = 1, DCV = 11, MINI = 00 DCR = 0, $I_L = 50$ mA	—	80	—	dB
Transmit Total Harmonic Distortion <sup>4</sup>	THD	ILIM = 0, DCV = 11, MINI = 00 DCR = 0, $I_L = 100$ mA	—	-72	—	dB
Transmit Total Harmonic Distortion <sup>4</sup>	THD	ILIM = 0, DCV = 00, MINI = 11 DCR = 0, $I_L = 20$ mA	—	-78	—	dB
Receive Total Harmonic Distortion <sup>4</sup>	THD	ILIM = 0, DCV = 00, MINI = 11 DCR = 0, $I_L = 20$ mA	—	-78	—	dB
Receive Total Harmonic Distortion <sup>4</sup>	THD	ILIM = 1, DCV = 11, MINI = 00 DCR = 0, $I_L = 50$ mA	—	-78	—	dB
Dynamic Range (Caller ID Mode)	$DR_{CID}$	$V_{IN} = 1$ kHz, -13 dBm	—	50	—	dB

**Notes:**

1. Measured at TIP and RING with 600  $\Omega$  termination at 1 kHz, as shown in Figure 1 on page 5.
2. Receive full scale level produces -0.9 dBFS at DTX.
3.  $DR = 20 \times \log |V_{in}| + 20 \times \log (\text{rms signal/rms noise})$ . Applies to both transmit and receive paths.  $V_{in} = 1$  kHz, -3 dBFS.
4.  $V_{in} = 1$  kHz, -3 dBFS.  $THD = 20 \times \log (\text{rms distortion/rms signal})$ .

Table 5. Absolute Maximum Ratings

Parameter	Symbol	Value	Unit
DC Supply Voltage	$V_D$	4.1	V
Input Current, Si2435/17 Digital Input Pins	$I_{IN}$	$\pm 10$	mA
Digital Input Voltage	$V_{IND}$	-0.3 to 5.3	V
CLKIN/XTALI Input Voltage	$V_{XIND}$	-0.3 to ( $V_D + 0.3$ )	V
Operating Temperature Range	$T_A$	-10 to 100	°C
Storage Temperature Range	$T_{STG}$	-40 to 150	°C

**Note:** Permanent device damage may occur if the above absolute maximum ratings are exceeded. Functional operation should be restricted to the conditions as specified in the operational sections of this data sheet. Exposure to absolute maximum rating conditions for extended periods may affect device reliability.

Table 6. Switching Characteristics

( $V_D = 3.0$  to  $3.6$  V,  $T_A = 0$  to  $70$  °C for F-Grade)

Parameter	Symbol	Min	Typ	Max	Unit
CLKOUT Output Clock Frequency		2.048	—	49.152	MHz
Baud Rate Accuracy	$t_{BD}$	-1	—	1	%
Start Bit $\downarrow$ to $\overline{RTS} \downarrow$	$t_{RTH}$	—	1/(2 x Baud Rate)	—	ns
$\overline{CTS}$ or $\overline{RTS} \uparrow$ High to Start Bit $\downarrow$	$t_{RTS}$	10	—	—	ns
Stop Bit $\uparrow$ to $\overline{CTS} \uparrow$	$t_{CTH}$	—	—	—	ns
$\overline{RESET} \downarrow$ to $\overline{RESET} \uparrow$	$t_{RS}$	5.0	—	—	ms
$\overline{RESET} \uparrow$ to 1st AT Command	$t_{AT}$	300	—	—	ms
Address Setup	$t_{AS}$	15	—	—	ns
Address Hold	$t_{AH}$	0	—	—	ns
$\overline{WR}$ Low Pulse Width	$t_{WL}$	50	—	—	ns
Write Data Setup Time	$t_{WDSU}$	20	—	—	ns
Write Cycle Time	$t_{WC}$	120	—	—	ns
Chip Select Setup	$t_{CSS}$	10	—	—	ns
Chip Select Hold	$t_{CSH}$	0	—	—	ns
$\overline{RD}$ Low Pulse Width	$t_{RL}$	50	—	—	ns
$\overline{RD}$ Low to Data Driven Time	$t_{RLDD}$	—	—	20	ns
Data Hold	$t_{DH}$	10	—	—	ns
$\overline{RD}$ High to Hi-Z Time	$t_{DZ}$	—	—	30	ns
Read Cycle Time	$t_{RC}$	120	—	—	ns

**Note:** All timing is referenced to the 50% level of the waveform. Input test levels are  $V_{IH} = V_D - 0.4$  V,  $V_{IL} = 0.4$  V

## UART Time for Modem Receive Path (8N1 Mode)

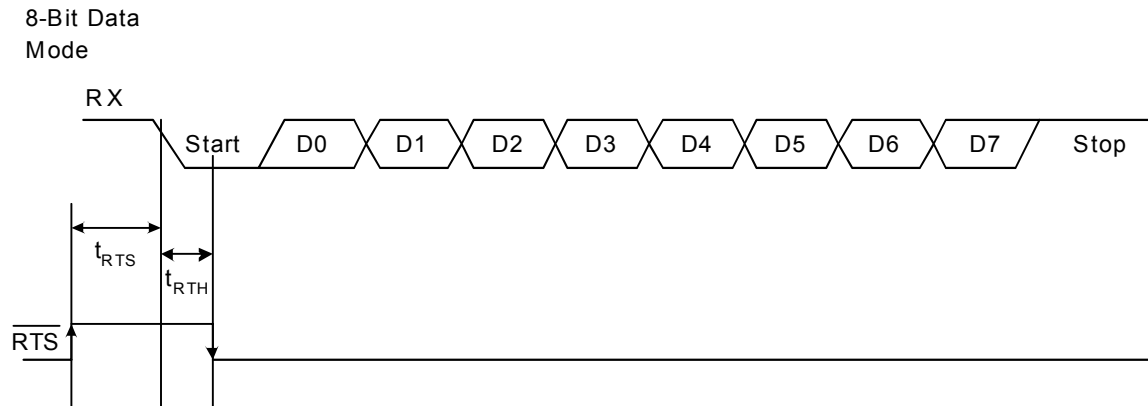

## UART Timing for Modem Transmit Path (9N1 Mode with 9th Bit Escape)

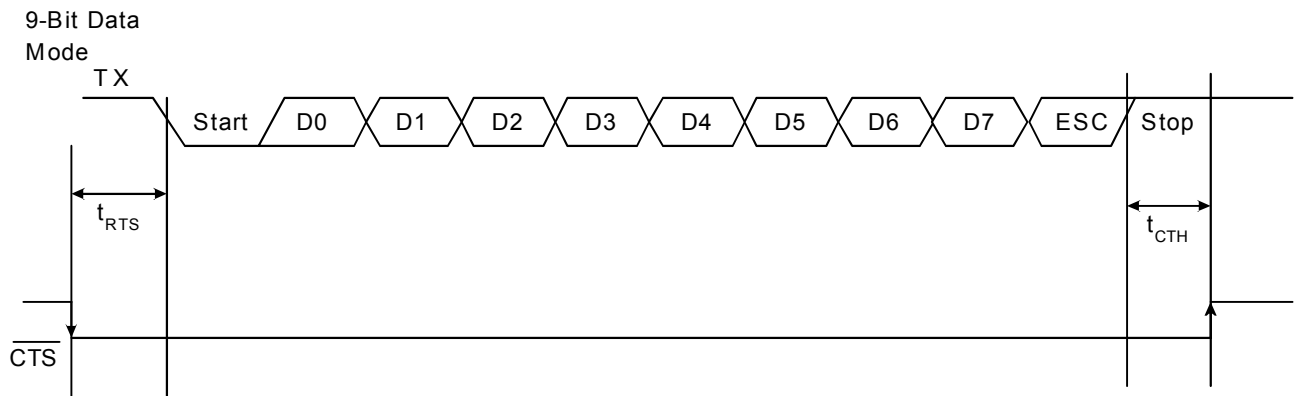

Figure 2. Asynchronous UART Serial Interface Timing Diagram

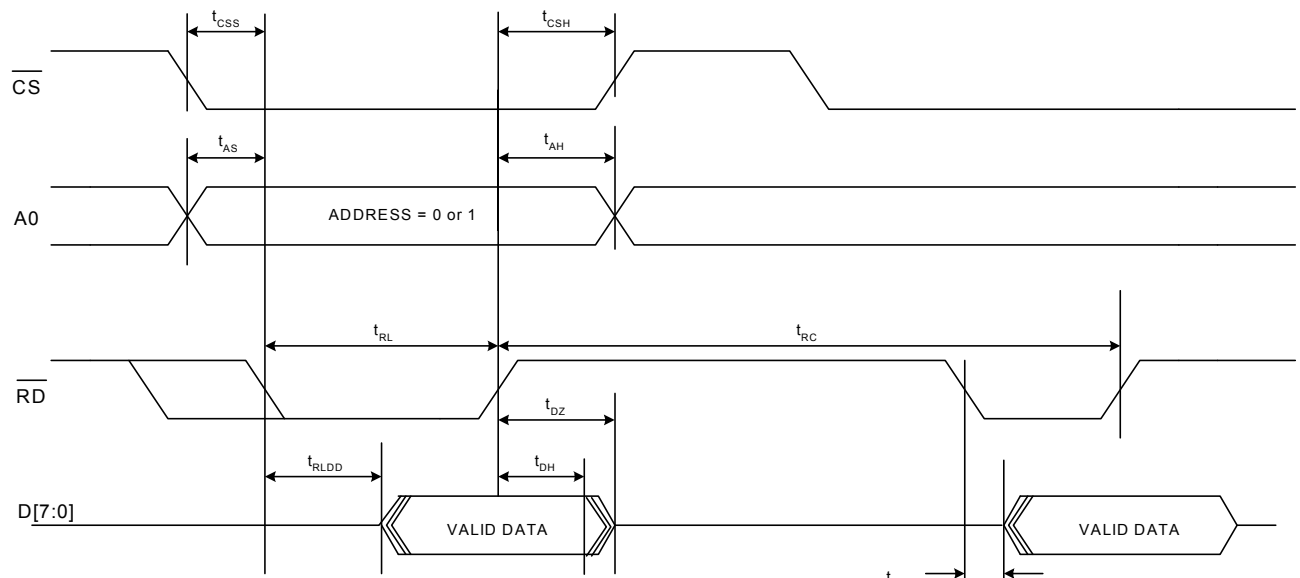

Figure 3. Parallel Interface Read Timing

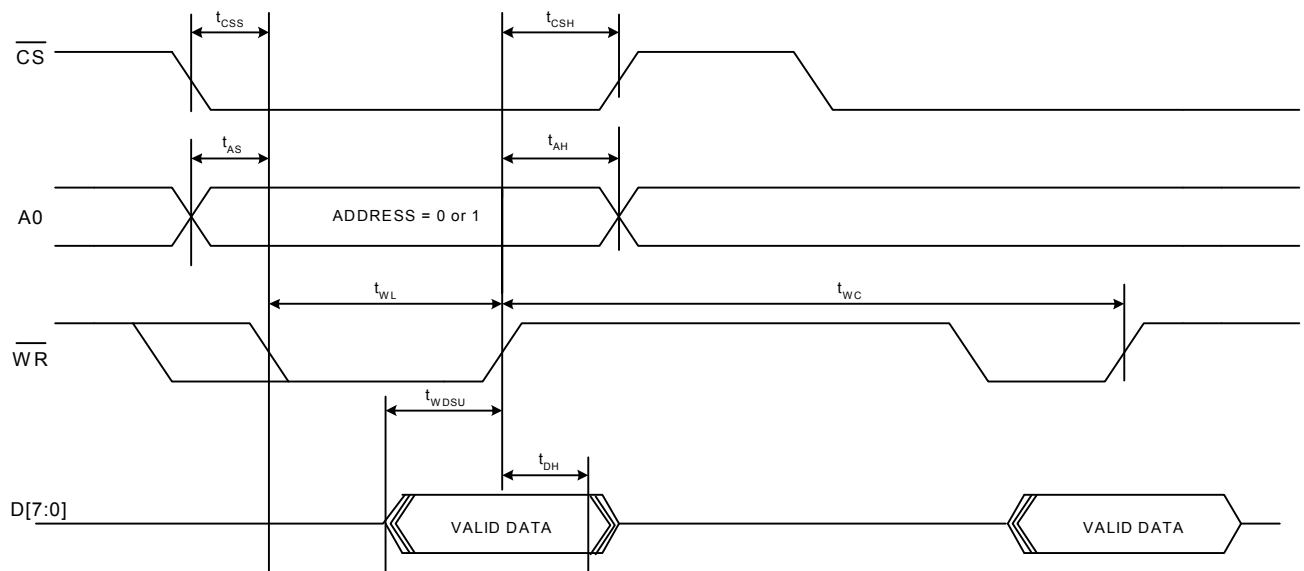
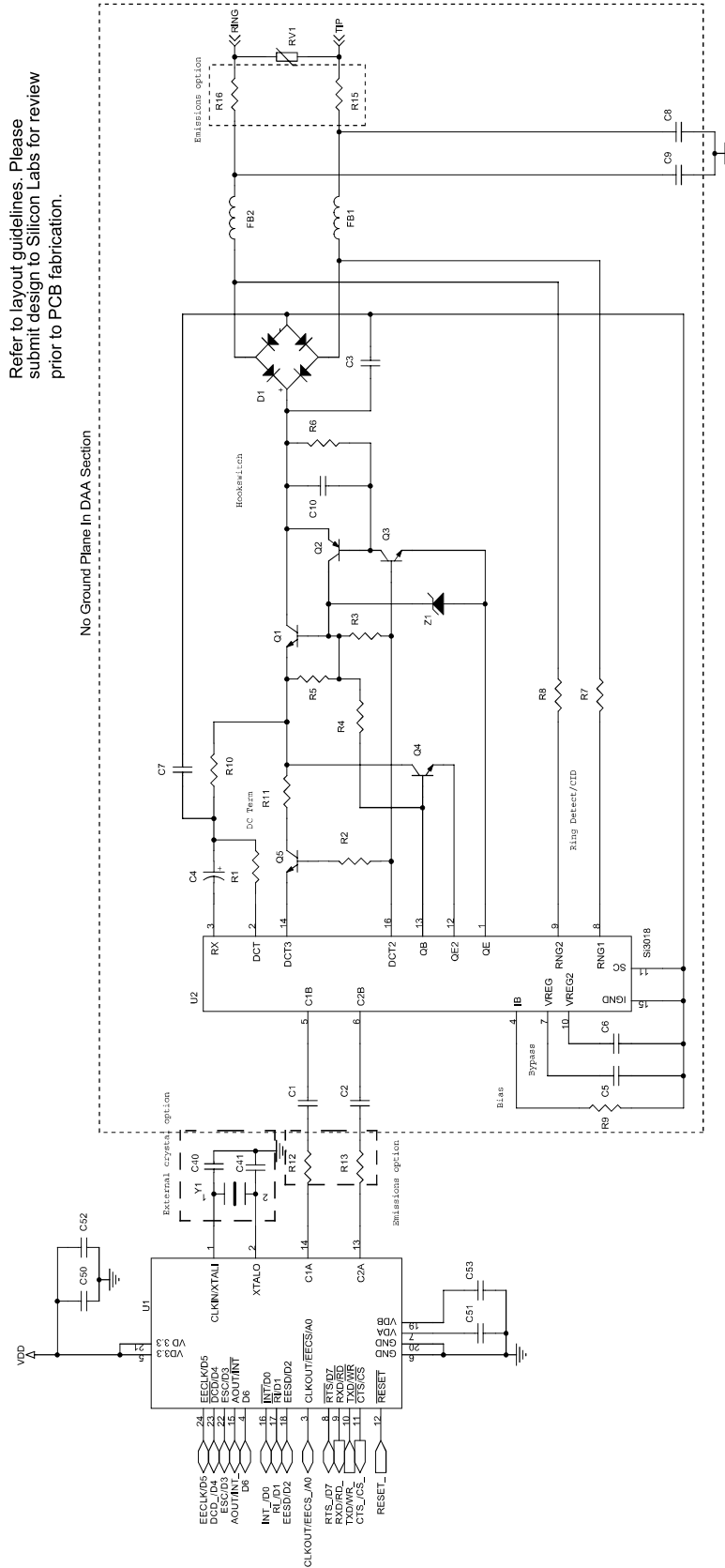

Figure 4. Parallel Interface Write Timing

## 2. Typical Application Schematic



## 3. Bill of Materials: Si2435/17 Chipset

Component	Value	Supplier(s)
C1, C2	33 pF, Y2, X7R, ±20%	Panasonic, Murata, Vishay
C3	10 nF, 250 V, X7R, ±20%	Venkel, SMEC
C4	1.0 μF, 50 V, Elec/Tant, ±20%	Panasonic
C5, C6, C50, C52	0.1 μF, 16 V, X7R, ±20%	Venkel, SMEC
C7	2.7 nF, 50 V, X7R, ±20%	Venkel, SMEC
C8, C9	680 pF, Y2, X7R, ±10%	Panasonic, Murata, Vishay
C10	0.01 μF, 16 V, X7R, ±20%	Venkel, SMEC
C40, C41 <sup>1</sup>	33 pF, 16 V, X7R, ±20%	Venkel, SMEC
C51, C53	0.22 μF, 16 V, X7R, ±20%	Venkel, SMEC
D1, D2 <sup>2</sup>	Dual Diode, 225 mA, 300 V, CMPD2004S	Central Semiconductor
FB1, FB2	Ferrite Bead, BLM21AG601SN1	Murata
Q1, Q3	NPN, 300 V, MMBTA42	OnSemi, Fairchild
Q2	PNP, 300 V, MMBTA92	OnSemi, Fairchild
Q4, Q5	NPN, 80 V, 330 mW, MMBTA06	OnSemi, Fairchild
RV1	Sidactor, 275 V, 100 A	Teccor, Protek, ST Micro
R1	1.07 kΩ, 1/2 W, 1%	Venkel, SMEC, Panasonic
R2	150 Ω, 1/16 W, 5%	Venkel, SMEC, Panasonic
R3	3.65 kΩ, 1/2 W, 1%	Venkel, SMEC, Panasonic
R4	2.49 kΩ, 1/2 W, 1%	Venkel, SMEC, Panasonic
R5, R6	100 kΩ, 1/16 W, 5%	Venkel, SMEC, Panasonic
R7, R8	20 MΩ, 1/16 W, 5%	Venkel, SMEC, Panasonic
R9	1 MΩ, 1/16 W, 1%	Venkel, SMEC, Panasonic
R10	536 Ω, 1/4 W, 1%	Venkel, SMEC, Panasonic
R11	73.2 Ω, 1/2 W, 1%	Venkel, SMEC, Panasonic
R12, R13 <sup>3</sup>	0 Ω, 1/16 W	Venkel, SMEC, Panasonic
R15, R16 <sup>4</sup>	0 Ω, 1/16 W	Venkel, SMEC, Panasonic
U1	Si2435/17	Silicon Labs
U2	Si3018	Silicon Labs
Y1 <sup>1,5</sup>	4.9152 MHz, 20 pF, 100 ppm, 150 Ω ESR	ECS Inc., Siward
Z1	Zener Diode, 43 V, 1/2 W, BZT84C43	On Semi

**Notes:**

1. In STB applications, C40, C41, and Y1 can be removed by using the 27 MHz clock input feature.
2. Several diode bridge configurations are acceptable. For example, a single DF04S or four 1N4004 diodes may be used.
3. 56 Ω, 1/16 W, 1% resistors may be substituted for R12–R13 (0 Ω) to decrease emissions.
4. Murata BLM21AG601SN1 may be substituted for R15–R16 (0 Ω) to decrease emissions.
5. To ensure compliance with ITU specifications, frequency tolerance must be less than 100 ppm including initial accuracy, 5-year aging, 0 to 70 °C, and capacitive loading. 50 ppm initial accuracy crystals typically satisfy this requirement.

**Table 7. Protocol Characteristics**

Item	Specification
<b>Fax Rate</b> 33.6 kbps* 31.2 kbps* 28.8 kbps* 26.4 kbps* 24.0 kbps* 21.6 kbps* 19.2 kbps* 16.8 kbps* 14.4 kbps 12.0 kbps 9600 bps 7200 bps 4800 bps 2400 bps	ITU-T V.34* ITU-T V.34* ITU-T V.34* ITU-T V.34* ITU-T V.34* ITU-T V.34* ITU-T V.34* ITU-T V.34* ITU-T V.34* ITU-T V.34*, or V.17 ITU-T V.34*, or V.17 ITU-T V.34*, V.29, or V.17 ITU-T V.34*, V.29, or V.17 ITU-T V.34*, or V.27ter ITU-T V.34*, V.22bis, or V.27ter
<b>Control Channel</b> 1200 bps 300 bps	ITU-T V.34bis* ITU-T V.21 channel 2
<b>Data Format</b> Bit asynchronous	Selectable 8, 9, 10, or 11 bits per character
<b>Fax Modulation</b> 2.4 to 33.6 kbps* 7.2 to 14.4 kbps 7200 to 9600 bps 2400 to 4800 bps 300 bps	V.34 as specified by ITU-T V.17 TCM as specified by ITU-T V.29 QAM as specified by ITU-T V.27 ter DPSK as specified by ITU-T V.21 channel 2 FSK as specified by ITU-T
<b>Transmit Carrier</b> V.34* ITU-T V.29 ITU-T V.22 Originate mode Answer mode ITU-T V.21 Originate mode Answer mode	As specified by ITU-T 1700 Hz ±1 Hz  1200 Hz ±0.5 Hz 2400 Hz ±1 Hz  Mark (980 Hz ±12 Hz) Space (1180 Hz ±12 Hz) Mark (1650 Hz ±12 Hz) Space (1850 Hz ±12 Hz)
<b>*Note:</b> Supported on Si2435 only.	

Table 7. Protocol Characteristics (Continued)

Item	Specification
<b>Receive Carrier</b> ITU-T V.34* ITU-T V.29 ITU-T V.22 Originate mode Answer mode ITU-T V.21 Originate mode Answer mode	As specified by ITU-T 1700 Hz $\pm$ 7 Hz  2400 Hz $\pm$ 7 Hz 1200 Hz $\pm$ 7 Hz  Mark (980 Hz $\pm$ 12 Hz) Space (1180 Hz $\pm$ 12 Hz) Mark (1650 Hz $\pm$ 12 Hz) Space (1850 Hz $\pm$ 12 Hz)
DTE Interface	EIA/TIA-232-E (ITU-T V.24/V.28/ISO 2110)
Line Equalization	Automatic Adaptive
Dialing	Pulse and Tone
<b>*Note:</b> Supported on Si2435 only.	

Confidential

## 4. Functional Description

The Si2435/17 ISModem<sup>®</sup> is a complete embedded fax modem chipset with integrated direct access arrangement (DAA) that provides a programmable line interface to meet global telephone line requirements. Available in two small packages, this solution includes a DSP data pump, modem controller, on-chip RAM and ROM, codec, DAA, analog output, and 27 MHz clock input.

The Si2435/17 ISModem is a full-featured fax modem chipset offering ITU-T T.31 compliant class 1 commands with fax connect rates up to 33.6/14.4 kbps over the Public Switched Telephone Network (PSTN).

The ISModem provides numerous additional features for fax modem applications. The modem includes full type I caller ID and type II caller ID in snoop mode for global standards, a data/fax call discriminator, DTMF tone generation and detection, and call progress monitoring. The modem is also programmable to meet global settings. Because the Si2435/17 ISModem integrates the DAA, analog features, such as parallel phone detect, overcurrent detection, and global PTT compliance with a single design, are included.

This device is ideal for fax modem applications due to its small board space, low power consumption, and global compliance. The Si2435/17 solution includes a silicon DAA using Silicon Laboratories' proprietary third-generation DAA technology. This highly-integrated DAA can be programmed to meet worldwide PTT specifications for ac termination, dc termination, ringer impedance, and ringer threshold. In addition, the Si2435/17 has been designed to meet the most stringent worldwide requirements for out-of-band energy, billing-tone immunity, surge immunity, and safety requirements.

The Si2435/17 provides a serial interface that can directly communicate to either a microcontroller via a UART interface or a PC via an RS-232 port. This interface allows for PC evaluation of the modem immediately upon powerup via the AT commands using standard terminal software. The Si2435/17 also provides an 8-bit parallel port.

### 4.1. Digital Interface

The Si2435/17 digital I/O can communicate via either a serial UART interface with flow control or via a parallel 8-bit interface.

Selection of a serial or parallel I/O interface is determined by the state of AOUT/ $\overline{\text{INT}}$  (Si2435/17, pin 15) during the rising edge of  $\overline{\text{RESET}}$ . An internal pullup resistor forces the default state to serial mode operation. An external 10 k $\Omega$  pulldown resistor can be

connected to AOUT/ $\overline{\text{INT}}$  to force selection of parallel mode (see Table 8). Configuration of pins 3, 4, 8–11, 15–18, and 22–24 is determined by this interface selection.

### 4.2. Serial Interface

The Si2435/17 supports asynchronous serial communication with data terminal equipment (DTE) at rates up to 307.2 kbps with the standard serial UART format. Upon powerup, the UART baud rate is automatically detected using the autobaud feature.

The serial interface also provides a hardware pin,  $\overline{\text{DCD}}$  (data carrier detect), which remains low as long as the ISModem is connected.

The  $\overline{\text{INT}}$  interrupt pin can be programmed to alert the host of changes to the interrupts listed in I/O Control 0 (U70).

#### 4.2.1. Autobaud

The Si2435/17 includes an automatic baud rate detection feature that allows the host to start transmitting data at any standard DTE rate from 300 bps to 307.2 kbps.

### 4.3. Parallel Interface

The parallel interface is an 8-bit data bus with a single bit address. Figure 3 on page 9 shows the required timing for the parallel interface.

If A0 = 0, the data bus represents a read/write to the "Parallel Interface 0 (0x00)" register on page 56. If A0 = 1, the data bus represents a read/write to the "Parallel Interface 1 (0x01)" register on page 57). See "AN60: Si2493/57/34/15/04 Parallel Interface Software" for details.

### 4.4. Command State

In command state, the ISModem is ready to accept commands from the host and is not communicating with a remote modem. Data signals from the host are treated as command lines, processed by the ISModem, and then, if appropriate, responses are sent back to the host. The command state is entered upon power-up and when a call is disconnected and is available in data mode, fax mode, or voice mode.

### 4.5. Data State

In data state, the ISModem is communicating with a remote modem. Data signals sent from the host are treated as data and transmitted to the remote modem via the ISModem, and data received from the remote modem are delivered via the ISModem to the host. Data and control signals are monitored by the ISModem to detect events, such as loss of the remote

connection and requests for disconnection or switching to command state. The data state is entered by successful completion of a command to originate or answer a call. For the Si2435/17 ISModem, data state is only operational in fax mode.

## 4.6. Data Mode (+FCLASS = 0)

The Si2435/17 has limited data mode support. In data mode, the Si2435/17 ISModem can be used for modem initialization and to detect incoming signals such as ringing and caller ID. The Si2435/17 does not support data modulations. If data modes are required, use the Si2457/34/15/04/01 ISModem family of devices. Data mode is enabled by the AT command, +FCLASS = 0, and is the default mode of operation.

## 4.7. Fax Mode (+FCLASS = 1)

The Si2435/17 fax ISModem supports super G3 (Si2435 only) and G3 fax communication. In fax mode, the Si2435 and Si2417 ISModem can answer or originate fax calls for speeds up to 33.6 kbps and 14.4 kbps respectively. Fax communication is supported through standard EIA/TIA 578 and ITU-T T.31 Class 1 AT commands, such as +FTM, +FRM, +FTH, +FRH, and +F34 (see Table 10 on page 18). Fax mode is enabled by the AT command +FCLASS = 1.

## 4.8. Voice Mode (+FCLASS = 8)

The Si2435/17 supports a voice mode. In voice mode, the ISModem monitors the telephone line for several events, such as DTMF detection, caller ID, and ringing tone. Once these events are detected, the ISModem will send either a simple event code (a single character) or a complex event code (multiple characters) preceded by a <DLE> character to the host. For a full list event reporting see Table 9. In voice mode, the ISModem can also generate DTMF and single tones using the +VTS command.

Voice mode is enabled by the AT command +FCLASS = 8. In voice mode, the +VLS command is used to enable event reporting and tone generation and to control the on/off hook state. Table 9 lists the events that are supported based on the +VLS state.

## 4.9. V.8 Call Establishment (Si2435 Only)

The Si2435 supports V.8 call establishment. Using the V.8 protocol, the Si2435 fax ISModem automatically negotiates with the remote modem for the best possible operational mode and speed. Upon successful V.34HD call establishment, the Si2435 will echo a "+F34: <rate>" response code prior to the CONNECT message.

To ensure interoperability with legacy G3 Fax Machines, if the remote modem does not support V.8, the Si2435 fax ISModem enters the command state to allow the host to initiate G3 operation as described in T.30. The Si2435 echoes an "OK" response code signifying the entrance to the command state. If enabled, the +A8 response codes can be sent to assist the host in determining the appropriate action.

If a fallback to G3 occurs, the host can optionally command the Si2435 to perform a V.8 retry via the AT+FTH=FSKL or AT+FRH=FSKL command. A V.8 retry allows for a possible transition back to V34HD Fax operation if V.8 negotiation fails, for instance, due to an ANSam misdetection during a manual call establishment described in the T.30 standard.

## 4.10. Data / Fax / Voice Discriminator

The Si2435/17 supports data/fax/voice discrimination via tone detection. In voice mode (+FCLASS = 8), if tone detection is enabled, the ISModem will report a "c" when fax calling tones are detected (1100 Hz). The ISModem will report an "e" when data calling tones are detected (1300 Hz). A "q" is reported when no tones are present for a preset amount of time. This "quiet" detection is generally perceived as a voice call. Using these event reports, the host can distinguish between a voice, data, or fax call.

## 4.11. DTMF Detection / Generation

The Si2435/17 provides comprehensive DTMF tone generation and detection. The ISModem can generate single tones or DTMF tones using the +VTS command. DTMF tones may also be generated during dialing using the "ATDT" command. DTMF detection is only available in voice mode (FCLASS = 8). DTMF digits are reported from the modem to the host using <DLE> shielding.

## 4.12. Caller ID Operation

The Si2435/17 fax ISModem supports global caller ID decode including US Bellcore, European ETSI, UK, Japanese, and DTMF protocols. The caller ID type is set using the +VCDT command. For example, +VCDT = 0 is Bellcore, +VCDT = 2 is UK and +VCDT = 3 is Japan caller ID mode. In addition, the Si2435/17 has an "always on" caller ID mode (+VCDT = 1), which snoops the line for data. This mode can be used for type II caller ID or non-standard caller ID implementations. The +VCID command is used to enable or disable caller ID formatting (see Table 10 on page 18 for more details).

## 4.13. Parallel Phone Detection

In voice mode, the Si2435/17 ISModem will automatically and unobtrusively detect when another telephone, modem, or other device is using the phone line. The ISModem will echo a <DLE>"P" if a remote device goes off-hook and will echo a <DLE>"p" when the remote device goes back on-hook. This allows the host to avoid interrupting another phone call when the phone line is already in use and to intelligently handle an interruption when the ISModem is utilizing the phone line.

## 4.14. Overcurrent Detection

The Si2435/17 includes an overcurrent detection feature that measures the loop current at a programmable time after the Si2435/17 goes off-hook. This allows the Si2435/17 to detect if it is connected to an improper telephone line. The overcurrent detection feature may be enabled by setting the OCDM bit (U70, bit 11). OHT (U77, bits 8:0) sets the delay after off-hook until the loop current is measured.

## 4.15. Global Operation

The Si2435/17 chipset contains an integrated silicon direct access arrangement (DAA) that provides a programmable line interface to meet international telephone line interface requirements.

Additionally, the user-access registers (via the AT:U and AT:R commands) may be programmed for country-specific settings, such as dial tone, ring, ringback, and busy tone.

## 4.16. Clocking

The Si2435/17 contains an on-chip phase-locked loop (PLL) and clock generator. Using either a single crystal or master clock input, the Si2435/17 can generate all the internal clocks required to support the featured modem protocols. Either a 27 MHz or 4.9152 MHz clock (3.3 V max input—see Table 5 on page 7) on XTALI or a 4.9152 MHz crystal across XTALI and XTALO form the master clock ( $\pm 100$  ppm max) for the ISModem. This

clock source is sent to an internal PLL that generates all necessary internal system clocks including the DSP clock.

By default, the Si2435/17 assumes a 4.9152 MHz clock input. If a 27 MHz clock on XTALI is used with the serial (UART) interface, a pulldown resistor  $\leq 10$  k $\Omega$  must be placed between DCD (pin 23) and GND. If a 27 MHz clock on XTALI is used with the parallel interface, a pulldown resistor  $\leq 10$  k $\Omega$  must be placed between CTS/CS (pin 11) and GND and AOUT/INT and GND (see Table 8).

Table 8. Pulldown Selector

Mode	Serial I/O	Parallel I/O
4.9152 MHz CLK	Default	Pin 15
27 MHz CLK	Pin 23	Pin 11, 15

## 4.17. Low-Power Modes

In order to reduce power consumption, the Si2435/17 fax ISModem may be placed in a wake-on-ring/sleep mode, or a complete powerdown mode. The sleep mode may be entered via the AT&Z command. Once the AT&Z command is issued, the ISModem will remain in sleep mode until either a ring is detected (triggering the INT pin and toggling the Ring Indicator (RI) bit low in U70) or a write to the TX FIFO. The ISModem may also be wakened out of sleep mode by a caller ID event.

Alternately, using the S24 S-register, the Si2435/17 can be set to automatically enter sleep mode after a pre-programmed time of inactivity with either the DTE or the remote modem. The sleep mode is entered after (S24) seconds have passed since the TX FIFO has been empty. Complete powerdown is accomplished via U65[13] (PDN). Once the PDN bit is written, the Si2435/17 completely powers down and can only be powered back on via the RESET pin.

Table 9. V.253 Event Reporting in Voice Mode

Event Description	Reporting	+VLS
Caller Id Report	Complex	0,4,20,21
Distinctive Ringing	Complex	0,4,20,21
RING	R	0,4,20,21
DTMF Received	1-9,A-D,*,#	1,5,20,21
Facsimile Calling (e.g. 1100 Hz)	c	1,5,20,21
Data Calling (e.g. 1300 Hz)	e	1,5,20,21
Presumed End of Message (QUIET) Time-out	q	1,5,20,21
Loop Current Interruption	l	1,5,20,21
Ringing Tone	r	1,5,20,21
BUSY	b	1,5,20,21
DIALTONE	d	1,5,20,21
Extension Phone On-hook	p	0,1,4,5,20,21
Extension Phone Off-hook	P	0,1,4,5,20,21
Facsimile or Data Answer (e.g. 2100 Hz)	a	1,5,20,21
Data Answer (e.g. 2225 Hz)	f	1,5,20,21

#### 4.18. Firmware Upgrades

The Si2435/17 contains an on-chip program ROM that includes the firmware required for the features listed in this data sheet. In addition, the Si2435/17 contains on-chip program RAM to accommodate minor changes to the firmware. This allows Silicon Labs to provide future firmware updates to optimize the characteristics of new modem designs and those already deployed in the field.

#### 4.19. Codec Interface

The Si2435/17 includes an optional serial interface that connects to an external voice codec (Si3000) for handset support.

#### 4.20. AT Commands

At powerup, the Si2435/17 is in the AT command mode. In command mode, the modem monitors the input (serial or parallel) checking constantly for a valid command (AT commands are described in Table 10.)

**Table 10. Basic AT Command Set (Command Defaults in Bold)**

Command	Action																		
\$	Display AT command mode settings.																		
A	Answer incoming call																		
A/	Re-execute last command. This is the only command not preceded by “AT” or followed by a <CR>.																		
Dn	<p>Dial</p> <p>The dial command, followed by 1 or more dial command modifiers, manually dials a phone number:</p> <table border="1"> <thead> <tr> <th>Modifier</th> <th>Function</th> </tr> </thead> <tbody> <tr> <td>! or &amp;</td> <td>Flash hook switch for FHT (U4F) ms (default: 500 ms)</td> </tr> <tr> <td>, or &lt;</td> <td>Pause before continuing for S8 seconds (default: 2 seconds)</td> </tr> <tr> <td>;</td> <td>Return to AT command mode</td> </tr> <tr> <td>@</td> <td>Wait for silence.</td> </tr> <tr> <td>L</td> <td>Redial last number.</td> </tr> <tr> <td>P</td> <td>Pulse (rotary) dialing—pulse digits: 0, 1, 2, 3, 4, 5, 6, 7, 8, 9</td> </tr> <tr> <td>T</td> <td>Tone (DTMF) dialing—DTMF digits: *, #, A, B, C, D, 0, 1, 2, 3, 4, 5, 6, 7, 8, 9.</td> </tr> <tr> <td>W</td> <td> <p>Wait for dial tone before continuing for S14 seconds (default: 12 seconds). Blind dialing modes X0, X1 and X3 do not affect the W command.</p> <p>If the DOP bit (U7A, bit 7) is set, the “ATDTW” command will cause the ISModem® to pause dialing and either report an “OK” if a dialtone is detected or “NO DIALTONE” if a dial tone is not detected.</p> </td> </tr> </tbody> </table>	Modifier	Function	! or &	Flash hook switch for FHT (U4F) ms (default: 500 ms)	, or <	Pause before continuing for S8 seconds (default: 2 seconds)	;	Return to AT command mode	@	Wait for silence.	L	Redial last number.	P	Pulse (rotary) dialing—pulse digits: 0, 1, 2, 3, 4, 5, 6, 7, 8, 9	T	Tone (DTMF) dialing—DTMF digits: *, #, A, B, C, D, 0, 1, 2, 3, 4, 5, 6, 7, 8, 9.	W	<p>Wait for dial tone before continuing for S14 seconds (default: 12 seconds). Blind dialing modes X0, X1 and X3 do not affect the W command.</p> <p>If the DOP bit (U7A, bit 7) is set, the “ATDTW” command will cause the ISModem® to pause dialing and either report an “OK” if a dialtone is detected or “NO DIALTONE” if a dial tone is not detected.</p>
Modifier	Function																		
! or &	Flash hook switch for FHT (U4F) ms (default: 500 ms)																		
, or <	Pause before continuing for S8 seconds (default: 2 seconds)																		
;	Return to AT command mode																		
@	Wait for silence.																		
L	Redial last number.																		
P	Pulse (rotary) dialing—pulse digits: 0, 1, 2, 3, 4, 5, 6, 7, 8, 9																		
T	Tone (DTMF) dialing—DTMF digits: *, #, A, B, C, D, 0, 1, 2, 3, 4, 5, 6, 7, 8, 9.																		
W	<p>Wait for dial tone before continuing for S14 seconds (default: 12 seconds). Blind dialing modes X0, X1 and X3 do not affect the W command.</p> <p>If the DOP bit (U7A, bit 7) is set, the “ATDTW” command will cause the ISModem® to pause dialing and either report an “OK” if a dialtone is detected or “NO DIALTONE” if a dial tone is not detected.</p>																		
En	Local DTE echo																		
E0	Disable																		
<b>E1</b>	<b>Enable</b>																		
Hn	Hook switch.																		
H0	Go on-hook (hang up modem).																		
H1	Go off-hook.																		
In	Identification and checksum.																		
I0	<p>Display Si2435/17 revision code.</p> <p>A: Revision A</p> <p>B: Revision B, etc.</p>																		
I1	Display Si2435/17 firmware revision code (numeric).																		
I3	<p>Display line-side revision code.</p> <p>18F = Si3018 revision F</p>																		
I6	<p>Display the ISModem® model number.</p> <p>“2417” = Si2417</p> <p>“2435” = Si2435</p>																		
I7	Diagnostic results 1.																		
<p><b>*Note:</b> This command should only be issued when the Si2435/17 is off-hook.</p>																			

Table 10. Basic AT Command Set (Command Defaults in Bold) (Continued)

Command	Action
I8	Diagnostic results 2.
Ln	Speaker volume operation
L1	Low speaker volume
L2	Medium speaker volume
L3	High speaker volume
Mn	Speaker operation (via AOUT).
<b>M0</b>	<b>Speaker is always off.</b>
M1	Speaker is on while dialing and handshaking; off in data mode.
M2	Speaker is always on.
M3	Speaker is off while dialing, on during handshaking and retraining.
Qn	Response mode.
<b>Q0</b>	<b>Enable result codes (see Table 12 on page 30)</b>
Q1	Disable result codes (enable quiet mode).
Sn	S-register operation (see Table 13 on page 32).
S\$	List contents of all S registers.
Sn?	Display contents of S-register n.
Sn=x	Set S-register n to value x (where n and x are decimal values).
Vn	Result code type (see Table 12 on page 30).
V0	Numeric result codes.
<b>V1</b>	<b>Verbal result codes</b>
Xn	Call Progress Monitor (CPM)—This command controls which CPM signals are monitored and reported to the host from the Si2435/17. (See Table 12 on page 30.)
X0	Basic results; disable CPM—Blind dial (does not wait for dial tone). CONNECT message does not include speed.
X1	Extended results; disable CPM—Blind dial. CONNECT message includes speed.
X2	Extended results and detect dial tone only—Add dial tone detection to X1 mode. Does not blind dial.
X3	Extended results and detect busy only—Add busy tone detection to X1 mode.
<b>X4</b>	<b>Extended results, full CPM—Full CPM enabled, CONNECT message includes speed.</b>
X5	Extended results—Full CPM enabled including ringback detection. Adds ringback detection to X4 mode.
Z	Hard Reset—This command is functionally equivalent to pulsing the $\overline{\text{RESET}}$ pin low. (See $t_{AT}$ in Table 6 on page 7.)
&\$	Display AT& current settings.
&D0	ESC (pin 22) is not used
&D1	<b>ESC (pin 22) escapes to command mode from data mode if also enabled by HES U70, bit 15.</b>
&D2	ESC (pin 22) assertion during a modem connection causes the modem to go on-hook and return to command mode.
<b>*Note:</b> This command should only be issued when the Si2435/17 is off-hook.	

**Table 10. Basic AT Command Set (Command Defaults in Bold) (Continued)**

Command	Action
&D3	ESC (pin 22) assertion causes ATZ command (reset and return OK result code).
&F	Restore factory default settings.
&Pn	Japan pulse dialing
&P0	Configure Si2435/17 for 10 pulse-per-second pulse dialing. For Japan.
&P1	Configure Si2435/17 for 20 pulse-per-second pulse dialing. For Japan.
&Tn	Test mode
&T0	Cancel test mode (Escape to command mode to issue AT&T0). This command will also report the number of bit errors encountered on the previous &T4 or &T5 test.
&T2	Initiate ITU-T V.54 (ANALOO) test. Modulation set by +MS AT command. Test loop is through the DSP (Si2435/17 device) only. ISModem® echoes data from TX pin (Register 0 in parallel mode) back to RX pin (Register 0 in parallel mode).
&T3	Initiate ITU-T V.54 (ANALOO) test. Modulation set by +MS AT command. Test loop is through the DSP (Si2435/17), DAA interface section (Si2435/17), DAA interface (Si3018), and analog hybrid circuit (Si3018). ISModem echoes data from TX pin (Register 0 in parallel mode) back to RX pin (Register 0 in parallel mode). Phone line termination required as in Figure 1. To test only the link operation, the hybrid and AFE codec can be removed from the test loop by setting the DL bit (U62, bit 1).
&T4	Initiate transmit as originating modem with automatic data generation. Modulation, data rate, and symbol rate are set by +MS and S41. Data pattern is set by the S40 register. Continues until the ATH command is sent after an escape into command mode. Data is also demodulated as in ANALOO, and any bit errors are counted to be displayed after the test using &T0.
&T5	Initiate transmit as answering modem with automatic data generation. Modulation, data rate, and symbol rate are set by +MS and S41. Data pattern is set by the S40 register. Continues until the ATH command is sent after an escape into command mode. Data is also demodulated as in ANALOO, and any bit errors are counted to be displayed after the test using &T0.
&T6	Compute checksum for firmware-upgradeable section of program memory. If no firmware upgrade is installed, &T6 returns 0x4474.
&Z	Enter low-power wake-on-ring mode.
\\$	Display AT\ command settings.
\Bn	Character length will be automatically set in autobaud mode
\B0	6N1—six data bits, no parity, one stop bit, one start bit, eight bits total (\N0 only) <sup>1</sup>
\B1	7N1—seven data bits, no parity, one stop bit, one start bit, nine bits total (\N0 only) <sup>1</sup>
\B2	7P1—seven data bits, parity optioned by \P, one stop bit, one start bit, 10 bits total
<b>\B3</b>	<b>8N1—eight data bits, no parity, one stop bit, one start bit, 10 bits total</b>
\B5	8P1—eight data bits, parity optioned by \P, one stop bit, one start bit, 11 bits total (\N0 only)
\B6	8X1—eight data bits, one escape bit, one stop bit, one start bit, 11 bits total (enables ninth-bit escape mode)
\Pn	Parity type will be automatically set in autobaud mode
<b>\P0</b>	<b>Even</b>
*Note: This command should only be issued when the Si2435/17 is off-hook.	

Table 10. Basic AT Command Set (Command Defaults in Bold) (Continued)

Command	Action								
\P1	Space <sup>1</sup>								
\P2	Odd								
\P3	Mark <sup>1</sup>								
\U	Serial mode—causes a low pulse (25 ms) on $\overline{RI}$ and $\overline{DCD}$ . $\overline{INT}$ to be the inverse of ESC. $\overline{RTS}$ to be inverse of $\overline{CTS}$ . Parallel mode—causes a low pulse (25 ms) on $\overline{INT}$ . This command terminates with a $\overline{RESET}$ .								
\Vn	Connect message type								
<b>\V0</b>	<b>Report connect message and protocol message</b>								
\V2	Report connect message only (exclude protocol message)								
\V4	Report connect and protocol message with both upstream and downstream connect rates.								
%%\$	Display AT% command settings.								
%Vn	Automatic Line Status Detection. After the %V1 and %V2 commands are issued, the Si2435/17 will automatically check the telephone connection for whether or not a line is present. If a line is present, the Si2435/17 will automatically check if the line is already in use. Finally, the Si2435/17 will check line status both before going off-hook and again before dialing.								
%V0	<b>Disable automatic line-in-use detection.</b>								
%V1	Automatic Line Status Detection. Description: Before going off-hook with the ATD, ATO, or ATA commands, the Si2435/17 compares the line voltage (via LVS) to registers NOLN (U83) and LIUS (U84):  <table border="0"> <tr> <td><u>Loop Voltage</u></td> <td><u>Action</u></td> </tr> <tr> <td><math>0 \leq LVS \leq NOLN</math></td> <td>Report “NO LINE” and remain on-hook.</td> </tr> <tr> <td><math>NOLN \leq LVS \leq LIUS</math></td> <td>Report “LINE IN USE” and remain on-hook.</td> </tr> <tr> <td><math>LIUS \leq LVS</math></td> <td>Go off-hook and establish a modem connection.</td> </tr> </table> Once the call has begun, the off-hook intrusion algorithm operates normally. In addition, the Si2435/17 will report “NO LINE” if the telephone line is completely disconnected. If the HOI bit (U77, bit 11) is set, “LINE IN USE” is reported upon intrusion.	<u>Loop Voltage</u>	<u>Action</u>	$0 \leq LVS \leq NOLN$	Report “NO LINE” and remain on-hook.	$NOLN \leq LVS \leq LIUS$	Report “LINE IN USE” and remain on-hook.	$LIUS \leq LVS$	Go off-hook and establish a modem connection.
<u>Loop Voltage</u>	<u>Action</u>								
$0 \leq LVS \leq NOLN$	Report “NO LINE” and remain on-hook.								
$NOLN \leq LVS \leq LIUS$	Report “LINE IN USE” and remain on-hook.								
$LIUS \leq LVS$	Go off-hook and establish a modem connection.								
:I	Interrupt Read—This command causes the ISOmodem® to report the lower 8 bits of the interrupt register I/O Control 0 (U70). The CID, OCD, PPD, and RI bits also are cleared, and the INT pin (INT bit in parallel mode) is deactivated on this read.								
:P	Program RAM Write—This command is used to upload firmware supplied by Silicon Labs to the Si2435/17. The format for this command is AT:Paaaa,xxxx,yyy,.... where aaaa is the first address in hexadecimal and xxxx,yyy,.... is data in hexadecimal. Only one :P command is allowed per AT command line. No other commands can be concatenated in the :P command line. This command is <i>only</i> for use with special files provided by Silicon Laboratories. Do not attempt to use this command for any other purpose.								
:R	User-Access Register Read—This command allows the user to read from the user-access registers. (See pages 35–55.) The format is “AT:Raa”, where aa = user-access address in hexadecimal. The “AT:R” command causes all the U- registers to be displayed.								
<b>*Note:</b> This command should only be issued when the Si2435/17 is off-hook.									

Table 10. Basic AT Command Set (Command Defaults in Bold) (Continued)

Command	Action
:U	User-Access Register Write—This command allows the user to write to the 16-bit user-access registers. (See page 35.) The format is “AT:Uaa,xxx,yyy,zzz,...” where aa = user-access address in hexadecimal. xxx = Data in hexadecimal to be written to location aa. yyy = Data in hexadecimal to be written to location (aa + 1). zzz = Data in hexadecimal to be written to location (aa + 2). etc.
+A8A : <value>	Answer signal indication <u>&lt;value&gt;</u> <u>Description</u> 0            Indicates that the ISModem timed out waiting for an answering signal 1            Indicates V.8 ANSam signal (2100 Hz with amplitude modulation) 2            Indicates V.25 answer tone (2100 Hz) 5            Indicates sigA signal: V.22bis USB1 signal 6            Indicates sigA signal: V.32bis AC signal
+A8C : <value>	Calling tone indication <u>&lt;value&gt;</u> <u>Description</u> 0            Indicates that the ISModem concluded answer tone transmission without reporting detection of any calling tone 1            Indicates a CNG tone (1100 Hz) 2            Indicates 1300 Hz V.25 data modem calling tone
+A8E = <v8o>,<v8a>	V.8 operation control <u>&lt;v8o&gt;</u> <u>Description</u> <b>1</b> <b>Enable ISModem controlled V.8 origination negotiation</b> 6        Enable ISModem controlled V.8 origination negotiation, issue +A8x indications  <u>&lt;v8a&gt;</u> <u>Description</u> <b>1</b> <b>Enable ISModem controlled V.8 answer negotiation</b> 5        Enable ISModem controlled V.8 answer negotiation, issue +A8x indications
+A8J: <value>	V.8 negotiation complete <u>&lt;value&gt;</u> <u>Description</u> 0            Indicates that the ISModem timed out waiting for a CJ signal 1            Indicates a CJ signal has been received by the remote modem
+A8M: <value>	V.8 menu report <u>&lt;value&gt;</u> <u>Description</u> 0            Indicates that the ISModem timed out waiting for a CM or JM signal <CM/JM hex string> This string is issued by either modem to indicate the contents of a valid received CM or JM signal.
+FCLASS = n	Fax mode select <u>n</u> <u>Mode</u> <b>0</b> <b>Data mode</b> 1        Fax class 1 / 1.0 mode 1.0      Fax class 1 / 1.0 mode 8        Voice mode
<b>*Note:</b> This command should only be issued when the Si2435/17 is off-hook.	

Table 10. Basic AT Command Set (Command Defaults in Bold) (Continued)

Command	Action
+FMI?	Report manufacturer ID. "Silicon Laboratories"
+FMM?	Report ISModem chipset model. <system-side> / <line-side> For example – "Si2435 / Si3018"
+FMR?	Report ISModem chipset revision. <system-side rev> / <line-side rev> For example – "A / F"
+FRH = n*	Receive Data with HDLC framing and carrier n. Only mandatory carrier, n = 3, supported.
+FRM = n*	Receive Data with carrier n. (See Table 11)
+FRS = n*	Report back to the DTE with an OK result code after n 10 ms intervals of silence have been detected on the line.
+FTH = n*	Transmit Data with HDLC framing and carrier n. Only mandatory carrier, n = 3, supported.
+FTM = n*	Transmit Data with carrier n. (See Table 11)
+FTS = n*	Stop transition and wait for n 10 ms intervals before responding with the OK result code.
+F34 options +F34 = A +F34 = A,B	Initial V.34 rate control This command is used to transmit or receive V.34 half-duplex data. V.34 full-duplex is not supported. The control channel remains fixed at 1200 bps. Upon a successful negotiation, a "+F34: <rate>" response code will be echoed. A Max rate for the primary channel in half-duplex operation. Values range from 1 (2400 bps) to 14 (33.6 kbps) in 2400 bps increments. The default value <b>0</b> selects a max rate of 33.6 kbps. B Min rate for the primary channel in half-duplex operation. Values range from 1 (2400 bps) to 14 (33.6 kbps) in 2400 bps increments. The default value <b>0</b> selects a min rate of 2400 bps.
<b>*Note:</b> This command should only be issued when the Si2435/17 is off-hook.	

**Table 10. Basic AT Command Set (Command Defaults in Bold) (Continued)**

Command	Action																																																																																						
+GCI = n	<p>Country settings - Automatically configure all registers for a particular country.</p> <table border="0"> <tr> <td><b>n</b></td> <td><b>Country</b></td> </tr> <tr> <td>0</td> <td>Japan</td> </tr> <tr> <td>9</td> <td>Australia</td> </tr> <tr> <td>A</td> <td>Austria</td> </tr> <tr> <td>F</td> <td>Belgium</td> </tr> <tr> <td>16</td> <td>Brazil</td> </tr> <tr> <td>1B</td> <td>Bulgaria</td> </tr> <tr> <td>20</td> <td>Canada</td> </tr> <tr> <td>26</td> <td>China</td> </tr> <tr> <td>27</td> <td>Columbia</td> </tr> <tr> <td>2E</td> <td>Czech Republic</td> </tr> <tr> <td>31</td> <td>Denmark</td> </tr> <tr> <td>35</td> <td>Ecuador</td> </tr> <tr> <td>3C</td> <td>Finland</td> </tr> <tr> <td>3D</td> <td>France</td> </tr> <tr> <td>42</td> <td>Germany</td> </tr> <tr> <td>46</td> <td>Greece</td> </tr> <tr> <td>50</td> <td>Hong Kong</td> </tr> <tr> <td>51</td> <td>Hungary</td> </tr> <tr> <td>53</td> <td>India</td> </tr> <tr> <td>57</td> <td>Ireland</td> </tr> <tr> <td>58</td> <td>Israel</td> </tr> <tr> <td>59</td> <td>Italy</td> </tr> <tr> <td>61</td> <td>South Korea</td> </tr> <tr> <td>69</td> <td>Luxembourg</td> </tr> <tr> <td>6C</td> <td>Malaysia</td> </tr> <tr> <td>73</td> <td>Mexico</td> </tr> <tr> <td>7B</td> <td>Netherlands</td> </tr> <tr> <td>7E</td> <td>New Zealand</td> </tr> <tr> <td>82</td> <td>Norway</td> </tr> <tr> <td>87</td> <td>Paraguay</td> </tr> <tr> <td>89</td> <td>Philippines</td> </tr> <tr> <td>8A</td> <td>Poland</td> </tr> <tr> <td>8B</td> <td>Portugal</td> </tr> <tr> <td>9C</td> <td>Singapore</td> </tr> <tr> <td>9F</td> <td>South Africa</td> </tr> <tr> <td>A0</td> <td>Spain</td> </tr> <tr> <td>A5</td> <td>Sweden</td> </tr> <tr> <td>A6</td> <td>Switzerland</td> </tr> <tr> <td>B8</td> <td>Russia</td> </tr> <tr> <td>B4</td> <td>United Kingdom</td> </tr> <tr> <td><b>B5</b></td> <td><b>United States</b></td> </tr> <tr> <td>FE</td> <td>Taiwan</td> </tr> </table> <p><b>Note:</b> U-registers are configured to Silicon Laboratories' recommended values. The +GCI command resets the U-registers and the S7 and S6 S-registers to default values before setting country-specific values. Changes may be made by writing individual registers after sending the AT+GCI command.</p>	<b>n</b>	<b>Country</b>	0	Japan	9	Australia	A	Austria	F	Belgium	16	Brazil	1B	Bulgaria	20	Canada	26	China	27	Columbia	2E	Czech Republic	31	Denmark	35	Ecuador	3C	Finland	3D	France	42	Germany	46	Greece	50	Hong Kong	51	Hungary	53	India	57	Ireland	58	Israel	59	Italy	61	South Korea	69	Luxembourg	6C	Malaysia	73	Mexico	7B	Netherlands	7E	New Zealand	82	Norway	87	Paraguay	89	Philippines	8A	Poland	8B	Portugal	9C	Singapore	9F	South Africa	A0	Spain	A5	Sweden	A6	Switzerland	B8	Russia	B4	United Kingdom	<b>B5</b>	<b>United States</b>	FE	Taiwan
<b>n</b>	<b>Country</b>																																																																																						
0	Japan																																																																																						
9	Australia																																																																																						
A	Austria																																																																																						
F	Belgium																																																																																						
16	Brazil																																																																																						
1B	Bulgaria																																																																																						
20	Canada																																																																																						
26	China																																																																																						
27	Columbia																																																																																						
2E	Czech Republic																																																																																						
31	Denmark																																																																																						
35	Ecuador																																																																																						
3C	Finland																																																																																						
3D	France																																																																																						
42	Germany																																																																																						
46	Greece																																																																																						
50	Hong Kong																																																																																						
51	Hungary																																																																																						
53	India																																																																																						
57	Ireland																																																																																						
58	Israel																																																																																						
59	Italy																																																																																						
61	South Korea																																																																																						
69	Luxembourg																																																																																						
6C	Malaysia																																																																																						
73	Mexico																																																																																						
7B	Netherlands																																																																																						
7E	New Zealand																																																																																						
82	Norway																																																																																						
87	Paraguay																																																																																						
89	Philippines																																																																																						
8A	Poland																																																																																						
8B	Portugal																																																																																						
9C	Singapore																																																																																						
9F	South Africa																																																																																						
A0	Spain																																																																																						
A5	Sweden																																																																																						
A6	Switzerland																																																																																						
B8	Russia																																																																																						
B4	United Kingdom																																																																																						
<b>B5</b>	<b>United States</b>																																																																																						
FE	Taiwan																																																																																						
+GCI?	List current country code setting (response is: + GCI:<setting>)																																																																																						
<p><b>*Note:</b> This command should only be issued when the Si2435/17 is off-hook.</p>																																																																																							

Table 10. Basic AT Command Set (Command Defaults in Bold) (Continued)

Command	Action
+GCI = ?	List all possible country code settings.
+GMI	Report manufacturer ID. "Silicon Laboratories"
+GMM	Report ISOmodem chipset number. <system-side> / <line-side> For example – "Si2435 / Si3018"
+GMR	Report ISOmodem chipset revision. <system-side rev> / <line-side rev> For example – "A / F"
+IFC Options +IFC = A +IFC = A,B	Specifies the flow control to be implemented. A Specifies the flow control method used by the host to control data from the modem 0 None 2 Hardware flow control (RTS) B Specifies the flow control method used by the modem to control data from the host 0 None 2 Hardware flow control (CTS).
+IPR = n	Select DTE rate <u>n</u> <u>Description</u> <b>0</b> <b>Automatically detect baud rate</b> 2400 DTE rate of 2400 bits/s 9600 DTE rate of 9600 bits/s 19200 DTE rate of 19.2 kbits/s 115200 DTE rate of 115.2 kbits/s Other DTE rates supported include: n = 300, 600, 1200, 4800, 7200, 12000, 14400, 38400, 57600, 230400, 245760, 307200
+ITF Options +ITF = A +ITF = A,B +ITF = A,B,C	Transmit flow control threshold. A Threshold above which the modem will generate a flow off signal <0 to 511> bytes B Threshold below which the modem will generate a flow on signal <0 to 511> bytes C Polling interval for <EM><BNUM> indicator 0 to 300 in 10 msec units.
+MR = n	Modulation reporting control. <u>n</u> <u>Mode</u> <b>0</b> <b>Disabled</b> 1 Enabled If enabled, the intermediate result code is transmitted at the point during connect negotiation. The format of this result code is as follows: +MCR: <carrier> e.g. +MCR: V34 +MRR: <rate> e.g. +MRR: 33600
<b>*Note:</b> This command should only be issued when the Si2435/17 is off-hook.	

**Table 10. Basic AT Command Set (Command Defaults in Bold) (Continued)**

Command	Action
+MS Options +MS = A +MS = A,B +MS = A,B,C +MS = A,B,C,D +MS = A,B,C,D,E +MS = A,B,C,D,E,F	<p>Modulation Selection.</p> <p>To be used in conjunction with &amp;Tn to set up loop back test modes at the appropriate modulation.</p> <p>A Preferred modem carrier</p> <p>V21 ITU-T V.21</p> <p>V22 ITU-T V.22</p> <p>V22B ITU-T V.22bis</p> <p>V32 ITU-T V.32</p> <p>V32B ITU-T V.32bis</p> <p>V34 ITU-T V.34</p> <p>B Automatic modulation negotiation</p> <p>0 Disabled</p> <p><b>1 Enabled</b></p> <p>C,D Min TX rate/Max TX rate are optional numeric values that specify the lowest value at which the DCE may establish a connection. If unspecified (set to 0), they are determined by the carrier and automode settings.</p> <p>E,F Min RX rate/Max RX rate are optional numeric values which specify the highest value at which the DCE may establish a connection. If unspecified (set to 0), they are determined by the carrier and automode settings.</p>
+VCDT = n	<p>Caller ID Type.</p> <p><u>n</u> <u>Mode</u></p> <p><b>0 After ring only</b></p> <p>1 Always on</p> <p>2 UK</p> <p>3 Japan</p> <p>4 DTMF after polarity reversal</p> <p>5 DTMF after polarity reversal (off-hook reception)</p> <p>6 Always on DTMF</p> <p>7 DTMF after ring</p>
+VCID = n	<p>Caller ID Enable.</p> <p><u>n</u> <u>Mode</u></p> <p><b>0 Off</b></p> <p>1 On—formatted</p> <p>2 On—raw data format</p>
+VDR = n	<p>Distinctive ring</p> <p><u>n</u> <u>Mode</u></p> <p><b>0 Disable distinctive ring</b></p> <p>1,0 Enable distinctive ring. The ISModem will report DROF and DRON result codes only. DROF and DRON are reported in 100 ms units.</p> <p>1,x Enable distinctive ring. The ISModem will report DROF and DRON result codes as well as well as a RING result code x/10 seconds after the falling edge of a ring pulse. DROF and DRON are reported in 100 ms units.</p>
+VIP	Load voice factory defaults
<p><b>*Note:</b> This command should only be issued when the Si2435/17 is off-hook.</p>	

Table 10. Basic AT Command Set (Command Defaults in Bold) (Continued)

Command	Action
+VLS = n	Analog source / destination select <u>n</u> <u>Description</u> <b>0</b> <b>ISModem on-hook. AOUT disabled. Tone detectors disabled.</b> 1    ISModem off-hook. AOUT disabled. Tone detectors disabled. 4    ISModem on-hook. AOUT connected to ISModem tone generators. Tone detectors disabled. 5    ISModem off-hook. AOUT connected to PSTN. Tone detectors enabled. 20   ISModem on-hook. AOUT disabled. Tone detectors enabled. 21   ISModem on-hook. AOUT connected to ISModem tone generators. Tone detectors enabled.
+VNH = <hook>	Automatic hangup control <u>&lt;hook&gt;</u> <u>Hook control description</u> <b>0</b> <b>The ISModem retains automatic hangups as is normal in the other modes (such as hanging up the phone when the ISModem does not detect a data carrier with a given time interval).</b> 1    The ISModem shall disable automatic hangups in the other non-voice modes. 2    The ISModem shall disable all hang-ups in other non-voice modes. The ISModem shall only perform a "logical" hangup (return the OK result code).
+VRA = n	Ringing tone goes away timer The ISModem only uses this command in call origination transactions. This command sets the amount of time in 0.1 second units the ISModem shall wait between Ringing Tone before it can assume that the remote modem has gone off-hook. Default time is 5 seconds.
+VRID = n	Repeat caller ID <u>n</u> <u>Description</u> 0    Display Caller ID information of the last incoming call in formatted form. 1    Display Caller ID information of the last incoming call in unformatted form.
+VRN = n	Ringing tone never appeared timer This command sets the amount of time in seconds the ISModem will wait looking for Ringing Tone. If the ISModem does not detect Ringing Tone in this time period, the ISModem shall assume that the remote station has gone off-hook, and return a OK result code. Default time is 0 seconds.
+VSD = <sds>, <sdi>	Silence detection <u>&lt;sds&gt;</u> Noise level sensitivity 127    Less aggressive [more sensitive, lower noise levels considered to be silence]. <b>128</b> <b>Nominal level of sensitivity.</b> 129    More aggressive [less sensitive, higher noise levels considered to be silence]. <u>&lt;sdi&gt;</u> sets the length of a time interval in 0.1 second units, which must contain no or little activity, before the ISModem will report (QUIET) (<DLE><q>). Default is five seconds.
<b>*Note:</b> This command should only be issued when the Si2435/17 is off-hook.	

**Table 10. Basic AT Command Set (Command Defaults in Bold) (Continued)**

<b>Command</b>	<b>Action</b>
+VTD = n	DTMF / Tone duration timer This command sets the default DTMF / tone generation duration in 10 ms units for the +VTS command. Default time is 1 second (n = 100).
+VTS = <string>	DTMF and tone generation This command can be used to produce DTMF tones, single-frequency tones, and double-frequency tones.
<b>*Note:</b> This command should only be issued when the Si2435/17 is off-hook.	

Confidential

Table 11. Carrier n

n	Modulation	Train time	Rate (bps)
3	V.21 ch 2	—	300
24	V.27 ter	—	2400
48	V.27 ter	—	4800
72	V.29	—	7200
73	V.17	Long	7200
74	V.17	Short	7200
96	V.29	—	9600
97	V.17	Long	9600
98	V.17	Short	9600
121	V.17	Long	12000
122	V.17	Short	12000
145	V.17	Long	14400
146	V.17	Short	14400
FSKL	V.8 retry	—	—

Confidential

**Table 12. Result Codes<sup>1</sup>**

Numeric	Meaning	Verbal Response	X0	X1	X2	X3	X4	X5
0	Command was successful	OK	X	X	X	X	X	X
1	Link established at 300 bps or higher	CONNECT	X	X	X	X	X	X
2	Incoming ring detected	RING	X	X	X	X	X	X
3	Link dropped	NO CARRIER	X	X	X	X	X	X
4	Command failed	ERROR	X	X	X	X	X	X
5	Link establish at 1200	CONNECT 1200		X	X	X	X	X
6	Dial tone not present	NO DIALTONE			X		X	X
7	Line busy	BUSY				X	X	X
8	Remote not answering	NO ANSWER	X	X	X	X	X	X
9	Ringback detected	RINGING						X
10	Link established at 2400	CONNECT 2400		X	X	X	X	X
11	Link established at 4800	CONNECT 4800		X	X	X	X	X
12	Link established at 9600	CONNECT 9600		X	X	X	X	X
14	Link established at 19200	CONNECT 19200 <sup>2</sup>		X	X	X	X	X
15	Link established at 7200	CONNECT 7200		X	X	X	X	X
16	Link established at 12000	CONNECT 12000		X	X	X	X	X
17	Link established at 14400	CONNECT 14400		X	X	X	X	X
18	Link established at 16800	CONNECT 16800 <sup>2</sup>		X	X	X	X	X
19	Link established at 21600	CONNECT 21600 <sup>2</sup>		X	X	X	X	X
20	Link established at 24000	CONNECT 24000 <sup>2</sup>		X	X	X	X	X
21	Link established at 26400	CONNECT 26400 <sup>2</sup>		X	X	X	X	X
22	Link established at 28800	CONNECT 28800 <sup>2</sup>		X	X	X	X	X
23	Link established at 31200	CONNECT 31200 <sup>2</sup>		X	X	X	X	X
24	Link established at 33600	CONNECT 33600 <sup>2</sup>		X	X	X	X	X
30	Caller ID mark detected	CIDM	X	X	X	X	X	X
31	Hookswitch flash detected	FLASH	X	X	X	X	X	X
32	UK CID State Tone Alert Signal detected	STAS	X	X	X	X	X	X
33	Overcurrent condition	X <sup>3</sup>	X	X	X	X	X	X
42	No phone line present	NO LINE (enabled via %Vn commands)	X	X	X	X	X	X
43	Telephone line is in use	LINE IN USE (enabled via %Vn commands)	X	X	X	X	X	X
44	A polarity reversal was detected	POLARITY REVERSAL (enabled via G modifier)	X	X	X	X	X	X

**Notes:**

1. The connect messages shown in this table are sent when link negotiation is complete.
2. This message is only supported on the Si2435.
3. X is the only verbal response code that does not follow the <CR><LF>Result Code<CR><LF> standard. There is no leading <CR><LF>.

Table 12. Result Codes<sup>1</sup> (Continued)

Numeric	Meaning	Verbal Response	X0	X1	X2	X3	X4	X5
45	A polarity reversal was NOT detected	NO POLARITY REVERSAL (enabled via G modifier)	X	X	X	X	X	X
75	Link established at 75	CONNECT 75		X	X	X	X	X
102	DTMF dial attempted on a pulse dial only line	UN-OBTAINABLE NUMBER	X	X	X	X	X	X

**Notes:**

1. The connect messages shown in this table are sent when link negotiation is complete.
2. This message is only supported on the Si2435.
3. X is the only verbal response code that does not follow the <CR><LF>Result Code<CR><LF> standard. There is no leading <CR><LF>.

Confidential

## 5. S-Registers

The S command allows reading (Sn?) or writing (Sn = x) the S-registers. The S-registers store values for functions that typically are rarely changed, such as timers or counters, and the ASCII values of control characters, such as carriage return. Table 13 summarizes the S-register set.

**Table 13. S-Register Description**

Definition				
S-Register (Decimal)	Function	Default (Decimal)	Range	Units
0	Automatic answer—Number of rings the Si2435/17 must detect before answering a call. 0 disables auto answer.	0	0–255	Rings
1	Ring counter.	0	0–255	Rings
2	ESC code character.	43 (+)	0–255	ASCII
3	Carriage return character.	13 (CR)	0–255	ASCII
4	Linefeed character.	10 (LF)	0–255	ASCII
5	Backspace character.	08 (BS)	0–255	ASCII
6	Dial tone wait timer—Number of seconds the Si2435/17 waits before blind dialing. Only applicable if blind dialing is enabled (X0, X1, X3).	02	0–255	seconds
7	Carrier wait timer—Number of seconds the Si2435/17 waits for carrier before timing out. This register also sets the number of seconds the modem waits for ring-back when originating a call before hanging up. This register also sets the number of seconds the answer tone will continue while using the AT*Y2A command.	80	0–255	seconds
8	Dial pause timer for , and < dial command modifiers.	02	0–255	seconds
9	Carrier presence timer—Time after a loss of carrier that a carrier must be detected before reactivating DCD. S9 is referred to as “carrier loss debounce time.”	06	1–255	0.1 second
10	Carrier loss timer—Time the carrier must be lost before the Si2435/17 disconnects. Setting 255 disables disconnect entirely. If S10 is less than S9, even a momentary loss of carrier causes a disconnect.	14	1–255	0.1 second
12	Escape code guard timer—Minimum guard time required before and after “+++” for the Si2435/17 to recognize a valid escape sequence.	50	1–255	0.02 second
14	Wait for dial tone delay value (in relation to the W dial modifier). Starts when “W” is executed in the dial string.	12	0–255	seconds

Table 13. S-Register Description (Continued)

Definition				
S-Register (Decimal)	Function	Default (Decimal)	Range	Units
24	Sleep Inactivity Time—Sets the time that the modem operates in normal power mode with no activity on the serial port, parallel port, or telephone line before entering low-power sleep mode. This feature is disabled if the timer is set to 0.	0	0–255	seconds
30	Disconnect Activity Timer—Sets the length of time that the modem stays online before disconnecting with no activity on the serial port, parallel port, or telephone line (Ring, hookswitch flash, or caller ID). This feature is disabled if set to 0.	0	0–255	minutes
38	Hang Up Delay Time—Maximum delay between receipt of ATH0 command and hang up. If time out occurs before all data can be sent, the NO CARRIER (3) result code is sent (operates in V.42 mode only). “OK” response is sent if all data is transmitted before timeout. S38 = 255 disables timeout and modem disconnects only if data is successfully sent or carrier is lost.	20	0–255	seconds
40	Data Pattern—Data pattern generated during &T4 and &T5 transmit tests. <b>0 = All spaces (0s)</b> 1 = All marks (1s) 2 = Random data	0	0–2	

**Table 13. S-Register Description (Continued)**

Definition																
S-Register (Decimal)	Function	Default (Decimal)	Range	Units												
41	<p>V.34 symbol rate - Symbol rate for V.34 when using the &amp;T4 and &amp;T5 commands.</p> <p><b>0 = 2400 symbols/second</b>                      1 = 2743 symbols/second                      2 = 2800 symbols/second                      3 = 3000 symbols/second                      4 = 3200 symbols/second                      5 = 3429 symbols/second</p> <p>A valid combination of symbol rate (S41) and data rate (&amp;G) must be selected.</p> <p><b><u>Symbol Rate</u>    <u>Allowable Data Rates</u></b></p> <table> <tr> <td>2400</td> <td>2400–21600</td> </tr> <tr> <td>2743</td> <td>4800–26400</td> </tr> <tr> <td>2800</td> <td>4800–26400</td> </tr> <tr> <td>3000</td> <td>4800–28800</td> </tr> <tr> <td>3200</td> <td>4800–31200</td> </tr> <tr> <td>3429</td> <td>4800–33600</td> </tr> </table>	2400	2400–21600	2743	4800–26400	2800	4800–26400	3000	4800–28800	3200	4800–31200	3429	4800–33600	0	0–5	
2400	2400–21600															
2743	4800–26400															
2800	4800–26400															
3000	4800–28800															
3200	4800–31200															
3429	4800–33600															
50	<p>Minimum on-hook time—Modem will remain on-hook for S50 seconds. Any attempt to go off-hook will be delayed until this timer expires.</p>	3	0–255	seconds												

## 6. User-Access Registers (U-Registers)

The :U AT command is used to write these 16-bit U-registers, and the :R command is used to read them. U-registers are identified by a hexadecimal (hex) address.

**Table 14. U-Register Description**

Register	Name	Description	Default
U00	DT1A0	DT1 registers set the coefficients for stage 1 of the Dial Tone Detect filter. Default is for FCC countries.	0x0800
U01	DT1B1		0x0000
U02	DT1B2		0x0000
U03	DT1A2		0x0000
U04	DT1A1		0x0000
U05	DT2A0	Dial tone detect filters stage 2 biquad coefficients.	0x00A0
U06	DT2B1		0x6EF1
U07	DT2B2		0xC4F4
U08	DT2A2		0xC000
U09	DT2A1		0x0000
U0A	DT3A0	Dial tone detect filters stage 3 biquad coefficients.	0x00A0
U0B	DT3B1		0x78B0
U0C	DT3B2		0xC305
U0D	DT3A2		0x4000
U0E	DT3A1		0xB50A
U0F	DT4A0	Dial tone detect filters stage 4 biquad coefficients.	0x0400
U10	DT4B1		0x70D2
U11	DT4B2		0xC830
U12	DT4A2		0x4000
U13	DT4A1		0x80E2
U14	DTK	Dial tone detect filter output scaler.	0x0009
U15	DTON	Dial tone detect ON threshold.	0x00A0
U16	DTOF	Dial tone detect OFF threshold.	0x0070

**Table 14. U-Register Description (Continued)**

Register	Name	Description	Default
U17	BT1A0	BT1 registers set the coefficients for stage 1 of the Busy Tone Detect filter. Default is for FCC countries.	0x0800
U18	BT1B1		0x0000
U19	BT1B2		0x0000
U1A	BT1A2		0x0000
U1B	BT1A1		0x0000
U1C	BT2A0	Busy tone detect filter stage 2 biquad coefficients.	0x00A0
U1D	BT2B1		0x6EF1
U1E	BT2B2		0xC4F4
U1F	BT2A2		0xC000
U20	BT2A1		0x0000
U21	BT3A0	Busy tone detect filter stage 3 biquad coefficients.	0x00A0
U22	BT3B1		0x78B0
U23	BT3B2		0xC305
U24	BT3A2		0x4000
U25	BT3A1		0xB50A
U26	BT4A0	Busy tone detect filter stage 4 biquad coefficients.	0x0400
U27	BT4B1		0x70D2
U28	BT4B2		0xC830
U29	BT4A2		0x4000
U2A	BT4A1		0x80E2
U2B	BTK	Busy tone detect filter output scaler.	0x0009
U2C	BTON	Busy tone detect ON threshold.	0x00A0
U2D	BTOF	Busy tone detect OFF threshold.	0x0070
U2E	BMTT	Busy cadence minimum total time in seconds multiplied by 7200.	0x0870
U2F	BDLT	Busy cadence delta in seconds multiplied by 7200.	0x25F8
U30	BMOT	Busy cadence minimum on time in seconds multiplied by 7200.	0x0438
U31	RMTT	Ringback cadence minimum total time in seconds multiplied by 7200.	0x4650
U32	RDLT	Ringback cadence delta in seconds multiplied by 7200.	0xEF10
U33	RMOT	Ringback cadence minimum on time in seconds multiplied by 7200.	0x1200

Table 14. U-Register Description (Continued)

Register	Name	Description	Default
U34	DTWD	Window to look for dialtone in seconds multiplied by 1000.	0x1B58
U35	DMOT	Minimum dialtone on time in seconds multiplied by 7200.	0x2D00
U37	PD0	Number of pulses to dial 0.	0x000A
U38	PD1	Number of pulses to dial 1.	0x0001
U39	PD2	Number of pulses to dial 2.	0x0002
U3A	PD3	Number of pulses to dial 3.	0x0003
U3B	PD4	Number of pulses to dial 4.	0x0004
U3C	PD5	Number of pulses to dial 5.	0x0005
U3D	PD6	Number of pulses to dial 6.	0x0006
U3E	PD7	Number of pulses to dial 7.	0x0007
U3F	PD8	Number of pulses to dial 8.	0x0008
U40	PD9	Number of pulses to dial 9.	0x0009
U42	PDBT	Pulse dial break time (ms units).	0x003D
U43	PDMT	Pulse dial make time (ms units).	0x0027
U45	PDIT	Pulse dial interdigit time (ms units).	0x0320
U46	DTPL	DTMF power level—16-bit format is 0x0(H)(L)0 where H is the (–)dBm level of the high-frequency DTMF tone and L is the (–)dBm level of the low-frequency DTMF tone. Note that twist may be specified here.	0x09B0
U47	DTNT	DTMF on time (ms units).	0x0064
U48	DTFT	DTMF off time (ms units).	0x0064
U49	RGFH	Ring frequency high—Maximum frequency ring to be considered a valid ring. RGFH = 2400/(maximum ring frequency).	0x0022
U4A	RGFD	Ring delta $RGFD = 2400 \text{ Hz} \times \left( \frac{1}{\text{min ring freq (Hz)}} \right) - \left( \frac{1}{\text{max ring freq (Hz)}} \right)$	0x007A
U4B	RGMN	Ring cadence minimum ON time in seconds multiplied by 2400.	0x0258
U4C	RGNX	Ring cadence maximum total time in seconds multiplied by 2400.	0x6720
U4D	MOD1	This is a bit-mapped register.	0x0000
U4E	PRDD	Pre-dial delay-time after ATD command that modem waits to dial (ms units). The Si2435/17 stays on-hook during this time.	0x0000

**Table 14. U-Register Description (Continued)**

Register	Name	Description	Default
U4F	FHT	Flash Hook Time. Time corresponding with “!” or “&” dial modifier that the Si2435/17 goes on-hook during a flash hook (ms units).	0x01F4
U50	LCDN	Loop current debounce on time (ms units).	0x015E
U51	LCDF	Loop current debounce off time (ms units).	0x00C8
U52	XMTL	Transmit level (1 dB units)—Sets the modem data pump transmitter level. Default level of 0 corresponds to $-9.85$ dBm. Transmit level = $-(9.85 + XMTL)$ dBm. Range = $-9.85$ to $-48$ .	0x0000
U62	DAAC1	This is a bit-mapped register.	0x0804
U63	DAAC3	This is a bit-mapped register.	
U65	DAAC4	This is a bit-mapped register.	0x00E0
U66	DAAC5	This is a bit-mapped register.	0x0040
U67	ITC1	This is a bit-mapped register.	0x0008
U68	ITC2	This is a bit-mapped register.	0x0000
U6A	ITC4	This is a bit-mapped register.	N/A
U6C	LVS	This is a bit-mapped register.	0x0000
U6E	CK1	This is a bit-mapped register.	0x1F20
U6F	PTMR	This is a bit-mapped register.	0x00FF
U70	IO0	This is a bit-mapped register.	0x2700
U71	IO1	This is a bit-mapped register.	0x0000
U76	GEN1	This is a bit-mapped register.	0x3240
U77	GEN2	This is a bit-mapped register.	0x401E
U78	GEN3	This is a bit-mapped register.	0x0000
U7A	GENA	This is a bit-mapped register.	0x0000
U7C	GENC	This is a bit-mapped register.	0x0000
U7D	GEND	This is a bit-mapped register.	0x0000
U83	NOLN	No-Line threshold. If %V1 is set, NOLN sets the threshold for determination of line present vs. line not present.	0x0001
U84	LIUS	Line-in-use threshold. If %V1 is set, LIUS sets the threshold for determination of line in use vs. line not in use.	0x0007
U85	NLIU	Line-in-use/No line threshold. If %V2 is set, NLIU sets the threshold reference for the adaptive algorithm (see %V2).	0x0000
U87	SAM	This is a bit-mapped register	0x0000

Table 14. U-Register Description (Continued)

Register	Name	Description	Default
U9F	SASF	SAS frequency detection.	0x0000
UA0	SC0	SAS cadence 0. Sets the duration of the first SAS tone (ms).	0x01E0
UA1	SC1	SAS cadence 1. Sets the duration of the first SAS silence (ms).	0x0000
UA2	SC2	SAS cadence 2. Sets the duration of the second SAS tone (ms).	0x0000
UA3	SC3	SAS cadence 3. Sets the duration of the second SAS silence (ms).	0x0000
UA4	SC4	SAS cadence 4. Sets the duration of the third SAS tone (ms).	0x0000
UA5	SC5	SAS cadence 5. Sets the duration of the third SAS silence (ms).	0x0000
UA6	SC6	SAS cadence 6. Sets the duration of the fourth SAS tone (ms).	0x0000
UA7	SC7	SAS cadence 7. Sets the duration of the fourth SAS silence (ms).	0x0000
UA8	SC8	SAS cadence 8. Sets the duration of the fifth SAS tone (ms).	0x0000
UA9	SC9	SAS cadence 9. Sets the duration of the fifth SAS silence (ms).	0x0000

Confidential



**Table 15. Bit-Mapped U-Register Summary**

Reg.	Name	Bit 15	Bit 14	Bit 13	Bit 12	Bit 11	Bit 10	Bit 9	Bit 8	Bit 7	Bit 6	Bit 5	Bit 4	Bit 3	Bit 2	Bit 1	Bit 0
U4D	MOD1		TOCT		NHFP	NHFD	CLPD		FTP	SPDM		GT18	GT55	CTE			
U62	DAAC1								OHS2						FOH	DL	
U63	DAAC3	LCS[7:0]							ACT[3:0]								
U65	DAAC4		PWMG	PDN									PDL				
U66	DAAC5										FDT						
U67	ITC1			MINI[1:0]				ILIM		DCR	OHS			DCV[1:0]		RZ	RT
U68	ITC2														BTE	ROV	BTD
U6A	ITC4													OVL			
U6C	LVS	LVS[7:0]															
U6E	CK1				R1[4:0]												
U6F	PTME										PTMR[7:0]						
U70	IO0	HES		TES	CIDM	OCDM	PPDM	RIM	DCDM				CID	OCD	PPD	RI	DCD
U71	IO1												COMP				PRT
U76	GEN1	OHSR[6:0]							FACL	DCL[2:0]			ACL[4:0]				
U77	GEN2	IST[3:0]				HOI		AOC	OHT[8:0]								
U78	GEN3	IB[1:0]							IS[7:0]								
U7A	GENA								DOP	ADD							
U7C	GENC											RIGPO					RIG-POEN
U7D	GEND		NLM													ATZD	FDP
U87	SAM						MINT	SERM	FSMS	XMTT							

## 6.1. Bit-Mapped U-Register Detail (defaults in bold)

## U4D MOD1

Bit	D15	D14	D13	D12	D11	D10	D9	D8	D7	D6	D5	D4	D3	D2	D1	D0
Name		TOCT		NHFP	NHFD	CLPD		FTP	SPDM		GT18	GT55	CTE			
Type	R/W			R/W	R/W	R/W		R/W	R/W		R/W	R/W	R/W			

Reset settings = 0x0000

Bit	Name	Function
15	Reserved	Read returns zero.
14	TOCT	<b>Turn Off Calling Tone.</b> <b>0 = Disable.</b> 1 = Enable.
13	Reserved	Read returns zero.
12	NHFP	<b>No Hook Flash Pulse.</b> <b>0 = Disable.</b> 1 = Enable.
11	NHFD	<b>No Hook Flash Dial.</b> <b>0 = Disable.</b> 1 = Enable.
10	CLPD	<b>Check Loop Current Before Dialing.</b> <b>0 = Ignore.</b> 1 = Check.
9	Reserved	Read returns zero.
8	FTP	<b>Force Tone or Pulse.</b> <b>0 = Disable.</b> 1 = Enable.
7	SPDM	<b>Skip Pulse Dial Modifier.</b> <b>0 = No.</b> 1 = Yes.
6	Reserved	Read returns zero.
5	GT18	<b>1800 Hz Guard Tone Enable.</b> <b>0 = Disable.</b> 1 = Enable.
4	GT55	<b>550 Hz Guard Tone Enable.</b> <b>0 = Disable.</b> 1 = Enable.
3	CTE	<b>Calling Tone Enable.</b> <b>0 = Disable.</b> 1 = Enable.
2:0	Reserved	Read returns zero.



# Si2435/Si2417

## U62 DAAC1

Bit	D15	D14	D13	D12	D11	D10	D9	D8	D7	D6	D5	D4	D3	D2	D1	D0
Name	0	0	0	0	1	0	0	OHS2	0	0	0	0	0	FOH	DL	0
Type	R/W											R/W	R/W			

Reset settings = 0x0804

Bit	Name	Function												
15:12	Reserved	Must be set to 0.												
11	Reserved	Must be set to 1.												
10:9	Reserved	Must be set to 0.												
8	OHS2	<b>On-Hook Speed 2.</b> This bit works in combination with the OHS bit (U67, bit 6) to set the on-hook speed. The on-hook speeds are measured from the time the OH bit is cleared until loop current equals zero. <table border="1"> <thead> <tr> <th>OHS</th> <th>OHS2</th> <th>Mean On-Hook Speed</th> </tr> </thead> <tbody> <tr> <td>0</td> <td>0</td> <td>Less than 0.5 ms</td> </tr> <tr> <td>0</td> <td>1</td> <td>3 ms <math>\pm</math>10% (meets ETSI standard)</td> </tr> <tr> <td>1</td> <td>X</td> <td>26 ms <math>\pm</math>10% (meets Australia spark quenching spec)</td> </tr> </tbody> </table>	OHS	OHS2	Mean On-Hook Speed	0	0	Less than 0.5 ms	0	1	3 ms $\pm$ 10% (meets ETSI standard)	1	X	26 ms $\pm$ 10% (meets Australia spark quenching spec)
OHS	OHS2	Mean On-Hook Speed												
0	0	Less than 0.5 ms												
0	1	3 ms $\pm$ 10% (meets ETSI standard)												
1	X	26 ms $\pm$ 10% (meets Australia spark quenching spec)												
7:3	Reserved	Must be set to 0.												
2	FOH	<b>Fast Off-Hook.</b> 0 = Automatic Calibration Time set to 426 ms. 1 = <b>Automatic Calibration Time set to 106 ms.</b>												
1	DL	<b>Isolation Digital Loopback (see the AT&amp;T commands).</b> 0 = Loopback occurs beyond the DAA interface, out to and including the analog hybrid circuit. 1 = Enables digital loopback mode across isolation barrier only.												
0	Reserved	Must be set to 0.												

**U63 DAAC3**

Bit	D15	D14	D13	D12	D11	D10	D9	D8	D7	D6	D5	D4	D3	D2	D1	D0
Name	LCS[7:0]							ACT[3:0]								
Type	R/W															

Reset settings = 0x0003

Bit	Name	Function
15:8	LCS[7:0]	Off-Hook Loop Current (1.1 mA/bit).
7:4	ACT[3:0]	<b>AC Termination Select.</b> <b>ACT[3:0] AC Termination</b> <b>0000 Real 600 <math>\Omega</math></b> 0011 220 $\Omega$ + (820 $\Omega$    120 nF) and 220 $\Omega$ + (820 $\Omega$    115 nF) 0100 370 $\Omega$ + (620 $\Omega$    310 nF) 1111 Global complex impedance
3:0	Reserved	Read returns 0x3.

**U65 DAAC4**

Bit	D15	D14	D13	D12	D11	D10	D9	D8	D7	D6	D5	D4	D3	D2	D1	D0
Name		PWMG	PDN									PDL				
Type		R/W	R/W									R/W				

Reset settings = 0x00E0

Bit	Name	Function
15	Reserved	Read returns zero.
14	PWMG	<b>PWM Gain.</b> <b>0 = No gain.</b> 1 = 6 dB gain applied to AOUT.
13	PDN	<b>Powerdown.</b> Completely powerdown the Si2435/17 and Si3018. Once set to 1, the Si2435/17 must be reset to power on. <b>0 = Normal.</b> 1 = Powerdown.
12:8	Reserved	Read returns zero.
7:5	Reserved	Must not change in a read-modify-write.
4	PDL*	<b>Powerdown Line-Side Chip.</b> <b>0 = Normal operation.</b> 1 = Places the Si3018 in powerdown mode.
3:0	Reserved	Must not change in a read-modify-write.

\*Note: Typically used only for board-level debug.

# Si2435/Si2417

## U66 DAAC5

Bit	D15	D14	D13	D12	D11	D10	D9	D8	D7	D6	D5	D4	D3	D2	D1	D0
Name										FDT						
Type	R															

Reset settings = 0x0040

Bit	Name	Function
15:7	Reserved	Read returns zero.
6	FDT*	<b>Frame Detect.</b> 0 = Indicates ISModem has not established frame lock. 1 = Indicates ISModem frame lock has been established.
5:4	Reserved	Read returns zero.
3:0	Reserved	Do not modify.

**\*Note:** Typically used only for board-level debug.

Confidential

## U67 ITC1

Bit	D15	D14	D13	D12	D11	D10	D9	D8	D7	D6	D5	D4	D3	D2	D1	D0
Name			MINI[1:0]				ILIM		DCR	OHS			DCV[1:0]		RZ	RT
Type	R/W			R/W			R/W	R/W	R/W	R/W	R/W		R/W	R/W	R/W	R/W

Reset settings = 0x0008

Bit	Name	Function												
15:14	Reserved	Read returns zero.												
13:12	MINI[1:0]	<p><b>Minimum Operational Loop Current.</b> Adjusts the minimum loop current at which the DAA can operate. Increasing the minimum operational loop current can improve signal headroom at a lower TIP/RING voltage.</p> <table border="1"> <thead> <tr> <th>MINI[1:0]</th> <th>Min Loop Current</th> </tr> </thead> <tbody> <tr> <td>00</td> <td>10 mA</td> </tr> <tr> <td>01</td> <td>12 mA</td> </tr> <tr> <td>10</td> <td>14 mA</td> </tr> <tr> <td>11</td> <td>16 mA</td> </tr> </tbody> </table>	MINI[1:0]	Min Loop Current	00	10 mA	01	12 mA	10	14 mA	11	16 mA		
MINI[1:0]	Min Loop Current													
00	10 mA													
01	12 mA													
10	14 mA													
11	16 mA													
11:10	Reserved	Read returns zero												
9	ILIM	<p><b>Current Limiting Enable.</b> <b>0 = Current limiting mode disabled.</b> 1 = Current limiting mode enabled. This mode limits loop current to a maximum of 60 mA per the TBR21 standard.</p>												
8	Reserved	Read returns zero.												
7	DCR	<p><b>DC Impedance Selection.</b> <b>0 = Normal dc impedance. This mode should be used for all standard applications.</b> 1 = 800 <math>\Omega</math> dc termination.</p>												
6	OHS	<p><b>On-Hook Speed.</b> This bit works in combination with the OHS2 bit (U62, bit 8) to set the on-hook speed. The on-hook speeds are measured from the time the OH bit is cleared until loop current equals zero.</p> <table border="1"> <thead> <tr> <th>OHS</th> <th>OHS2</th> <th>Mean On-Hook Speed</th> </tr> </thead> <tbody> <tr> <td>0</td> <td>0</td> <td>Less than 0.5 ms</td> </tr> <tr> <td>0</td> <td>1</td> <td>3 ms <math>\pm</math>10% (meets ETSI standard)</td> </tr> <tr> <td>1</td> <td>X</td> <td>26 ms <math>\pm</math>10% (meets Australia spark quenching spec)</td> </tr> </tbody> </table>	OHS	OHS2	Mean On-Hook Speed	0	0	Less than 0.5 ms	0	1	3 ms $\pm$ 10% (meets ETSI standard)	1	X	26 ms $\pm$ 10% (meets Australia spark quenching spec)
OHS	OHS2	Mean On-Hook Speed												
0	0	Less than 0.5 ms												
0	1	3 ms $\pm$ 10% (meets ETSI standard)												
1	X	26 ms $\pm$ 10% (meets Australia spark quenching spec)												
5:4	Reserved	Read returns zero.												
3:2	DCV[1:0]	<p><b>TIP/RING Voltage Adjust.</b> These bits adjust the voltage on the DCT pin of the line-side device, which affects the TIP/RING voltage on the line. Low voltage countries should use a lower TIP/RING voltage. Raising the TIP/RING voltage can improve signal headroom.</p> <table border="1"> <thead> <tr> <th>DCV[1:0]</th> <th>DCT Pin Voltage</th> </tr> </thead> <tbody> <tr> <td>00</td> <td>3.1 V</td> </tr> <tr> <td>01</td> <td>3.2 V</td> </tr> <tr> <td><b>10</b></td> <td><b>3.35 V</b></td> </tr> <tr> <td>11</td> <td>3.5 V</td> </tr> </tbody> </table>	DCV[1:0]	DCT Pin Voltage	00	3.1 V	01	3.2 V	<b>10</b>	<b>3.35 V</b>	11	3.5 V		
DCV[1:0]	DCT Pin Voltage													
00	3.1 V													
01	3.2 V													
<b>10</b>	<b>3.35 V</b>													
11	3.5 V													

# Si2435/Si2417

Bit	Name	Function
1	RZ	<b>Ringer Impedance.</b> <b>0 = Maximum (high) ringer impedance.</b> 1 = Synthesize ringer impedance. C15, R14, Z2, and Z3 must not be installed when setting this bit.
0	RT	<b>Ringer Threshold Select.</b> Used to satisfy country requirements on ring detection. Signals below the lower level does not generate a ring detection; signals above the upper level are guaranteed to generate a ring detection. <b>0 = 11 to 22 V<sub>rms</sub>.</b> <b>1 = 17 to 33 V<sub>rms</sub>.</b>

## U68 ITC2

Bit	D15	D14	D13	D12	D11	D10	D9	D8	D7	D6	D5	D4	D3	D2	D1	D0
Name														BTE	ROV	BTD
Type														R/W	R/W	R/W

Reset settings = 0x0000

Bit	Name	Function
15:3	Reserved	Do not modify.
2	BTE	<b>Billing Tone Protect Enable.</b> <b>0 = Disabled.</b> 1 = Enabled. When set, the DAA responds automatically to a collapse of the line-derived power supply during a billing tone event. When off-hook, if BTE = 1 and BTD goes high, the dc termination is released (800 Ω presented to line). If BTE and RIM (U70, bit 9) are set, an RI (U70, bit 1) interrupt also occurs when BTD goes high.
1	ROV	<b>Receive Overload.</b> The bit is set when the receive input (i.e., receive pin goes below ground) has an excessive input level. This bit is cleared by writing a 0 to this location. <b>0 = Normal receive input level.</b> 1 = Excessive receive input level.
0	BTD	<b>Billing Tone Detected.</b> This bit is set if a billing tone is detected. This bit is cleared by writing a 0 to this location. 0 = No billing tone. 1 = Billing tone detected.

**U6A ITC4**

Bit	D15	D14	D13	D12	D11	D10	D9	D8	D7	D6	D5	D4	D3	D2	D1	D0
Name														OVL		
Type	R															

Reset settings = N/A

Bit	Name	Function
15:3	Reserved	Read returns zero.
2	OVL	<b>Overload Detected.</b> This bit has the same function as ROV, but clears itself after the overload has been removed. This bit is not affected by the BTE bit.
1:0	Reserved	Do not modify.

**U6C LVS**

Bit	D15	D14	D13	D12	D11	D10	D9	D8	D7	D6	D5	D4	D3	D2	D1	D0
Name	LVS[7:0]															
Type	R															

Reset settings = 0x0000

Bit	Name	Function
15:8	LVS[7:0]	<b>Line Voltage Status.</b> Eight bit signed, twos complement number representing the tip-ring voltage. Each bit represents 1 V. Polarity of the voltage is represented by the MSB (sign bit). 0000_0000 = Measured voltage is < 3 V.
7:0	Reserved	Read returns zero.

# Si2435/Si2417

## U6E CK1

Bit	D15	D14	D13	D12	D11	D10	D9	D8	D7	D6	D5	D4	D3	D2	D1	D0
Name				R1[4:0]												
Type	R/W															

Reset settings = 0x1F20

Bit	Name	Function
15:13	Reserved	Do not modify.
12:8	R1[4:0]	<b>R1 CLKOUT Divider.</b>
7:0	Reserved	Read returns zero.

## U6F PTMR

Bit	D15	D14	D13	D12	D11	D10	D9	D8	D7	D6	D5	D4	D3	D2	D1	D0
Name												PTMR[7:0]				
Type	R/W															

Reset settings = 0x00FF

Bit	Name	Function
15:8	Reserved	Do not modify
7:0	PTMR[7:0]	<b>Parallel Port Receive FIFO Interrupt Timer.</b>

## U70 IO0

Bit	D15	D14	D13	D12	D11	D10	D9	D8	D7	D6	D5	D4	D3	D2	D1	D0
Name	HES		TES	CIDM	OCDM	PPDM	RIM	DCDM	0			CID	OCD	PPD	RI	DCD
Type	R/W		R/W	R/W	R/W	R/W	R/W	R/W				R/W	R/W	R/W	R/W	R/W

Reset settings = 0x2700

Bit	Name	Function
15	HES	<b>Hardware Escape Pin.</b> 0 = Disable. 1 = Enable.
14	Reserved	Read returns zero.
13	TES	<b>Enable “+++” Escape.</b> 0 = Disable. 1 = Enable.
12	CIDM	<b>Caller ID Mask.</b> 0 = Change in CID will not affect INT. 1 = A low to high transition in CID activates $\overline{\text{INT}}$ .
11	OCDM	<b>Overcurrent Detect Mask.</b> 0 = Change in OCD does not affect INT. (“X” result code is not generated in command mode.) 1 = A low to high transition in OCD will activate INT. (“X” result code is generated in command mode.)
10	PPDM	<b>Parallel Phone Detect Mask.</b> 0 = Change in PPD does not affect $\overline{\text{INT}}$ . 1 = A low to high transition in PPD will activate INT.
9	RIM	<b>Ring Indicator.</b> 0 = Change in RI does not affect $\overline{\text{INT}}$ . 1 = A low to high transition in RI activates INT.
8	DCDM	<b>Data Carrier Detect Mask.</b> 0 = Change in DCD does not affect $\overline{\text{INT}}$ . 1 = A high to low transition in DCD (U70, bit 0), which indicates loss of carrier, activates INT.
7	Reserved	Must be set to zero.
6:5	Reserved	Read returns zero.
4	CID	<b>Caller ID (sticky).</b> Caller ID preamble has been detected; data will soon follow. Clears on :I read.
3	OCD	<b>Overcurrent Detect (sticky).</b> Overcurrent condition has occurred. Clears on :I read.
2	PPD	<b>Parallel Phone Detect (sticky).</b> Parallel phone detected since last off-hook event. Clears on :I read.
1	RI	<b>Ring Indicator.</b> Active high bit when the Si2435/17 is on-hook, indicates ring event has occurred. Clears on :I read.
0	DCD	<b>Data Carrier Detect (status).</b> Active high bit indicates carrier detected (equivalent to inverse of $\overline{\text{DCD}}$ pin).



# Si2435/Si2417

## U71 IO1

Bit	D15	D14	D13	D12	D11	D10	D9	D8	D7	D6	D5	D4	D3	D2	D1	D0
Name												COMP				PRT
Type												R/W				R/W

Reset settings = 0x0000

Bit	Name	Function
15:5	Reserved	Read returns zero.
4	COMP	<b>0 = Disables compression (PCM mode).</b> 1 = Enables linear compression.
3:1	Reserved	Read returns zero.
0	PRT	<b>0 = Disables PCM mode.</b> 1 = Enables PCM mode.

## U76 GEN1

Bit	D15	D14	D13	D12	D11	D10	D9	D8	D7	D6	D5	D4	D3	D2	D1	D0
Name	OHSR[6:0]						FACL	DCL[2:0]			ACL[4:0]					
Type	R/W							R/W			R/W					

Reset settings = 0x3240

Bit	Name	Function
15:9	OHSR[6:0]	<b>Off-Hook Sample Rate (40 ms units).</b> Sets the sample rate for the off-hook intrusion algorithms (1 second default).
8	FACL	<b>Force ACL.</b> <b>0 = While off-hook, ACL is automatically updated with LCS.</b> 1 = While off-hook, ACL does not change from the value written to it while on-hook.
7:5	DCL[2:0]	<b>Differential Current Level (3 mA units).</b> Sets the differential level between ACL and LCS that will trigger an off-hook PPD interrupt (default = 2).
4:0	ACL[4:0]	<b>Absolute Current Level (3 mA units).</b> ACL represents the value of LCS current when the ISOmodem® is off-hook and all parallel phones are on-hook. If ACL = 0, it is ignored by the off-hook intrusion algorithm. The ISOmodem will also write ACL with the contents of LCS before an intrusion and before going on-hook (default = 0).

## U77 GEN2

Bit	D15	D14	D13	D12	D11	D10	D9	D8	D7	D6	D5	D4	D3	D2	D1	D0
Name	IST[3:0]				HOI		AOC	OHT[8:0]								
Type	R/W				R/W		R/W			R/W						

Reset settings = 0x401E

Bit	Name	Function
15:12	IST[3:0]	<b>Intrusion Settling Time (250 ms units).</b> Delay between when the ISModem goes off-hook and the off-hook intrusion algorithm begins. Default is 1 s.
11	HOI	<b>Hang-Up On Intrusion.</b> <b>0 = ISModem will not automatically hang up when an off-hook PPD interrupt occurs.</b> 1 = ISModem automatically hangs up on a PPD interrupt. If %Vn commands are set, HOI also causes the "LINE IN USE" result code upon PPD interrupt.
10	Reserved	Read returns zero.
9	AOC	<b>Auto Overcurrent.</b> <b>0 = Disable.</b> 1 = Enable. <b>Note:</b> AOC may falsely detect an overcurrent condition in the presence of line reversals or other transients. Therefore, this feature should not be used in applications or locations (such as Japan) where line reversals are common or may be expected.
8:0	OHT[8:0]	<b>Off-Hook Time (1 ms units).</b> Time before LCS is checked for overcurrent condition after going off-hook (30 ms default).

# Si2435/Si2417

## U78 GEN3

Bit	D15	D14	D13	D12	D11	D10	D9	D8	D7	D6	D5	D4	D3	D2	D1	D0
Name	IB[1:0]											IS[7:0]				
Type	R/W										R/W					

Reset settings = 0x0000

Bit	Name	Function
15:14	IB[1:0]	<p><b>Intrusion Blocking.</b>                      Defines the method used to block the off-hook intrusion algorithm from operation after dialing has begun.</p> <p><b>0 = No intrusion blocking.</b>                      1 = Intrusion disabled from start of dial to end of dial.                      2 = Intrusion disabled from start of dial to IS register time-out.                      3 = Intrusion disabled from start of dial to connect (“CONNECT XXX”, “NO DIALTONE”, or “NO CARRIER”).</p>
13:8	Reserved	Read returns zero.
7:0	IS[7:0]	<p><b>Intrusion Suspend (500 ms units).</b>                      When IB = 2, this register sets the length of time from when dialing begins that the off-hook intrusion algorithm is blocked (suspended) (default = 00000000<sub>b</sub>).</p>

## U7A GENA

Bit	D15	D14	D13	D12	D11	D10	D9	D8	D7	D6	D5	D4	D3	D2	D1	D0
Name									DOP	ADD						
Type									R/W	R/W						

Reset settings = 0x0000

Bit	Name	Function
15:8	Reserved	Read returns to zero.
7	DOP	<b>Dial or Pulse.</b> <b>0 = Normal ATDTW operation</b> 1 = Use ATDTW for Pulse/Tone Dial Detection (see also ATDW command)
6	ADD	<b>Adaptive Dialing</b> 1 = Enable <b>0 = Disable</b> Attempt DTMF dial, then fall back to pulse dialing if unsuccessful. First digit is dialed as DTMF. If a dialtone is still present after two seconds, the Si2435/17 will redial the first digit and remaining digits as pulse. If a dialtone is not present after two seconds, the Si2435/17 will dial the remaining digits as DTMF.
5:0	Reserved	Read returns to zero.

Confidential

# Si2435/Si2417

## U7C GENC

Bit	D15	D14	D13	D12	D11	D10	D9	D8	D7	D6	D5	D4	D3	D2	D1	D0
Name												RIGPO				RIGPIOEN
Type	R											R/W				

Reset settings = 0x0000

Bit	Name	Function
15:5	Reserved	Reads returns to zero.
4	RIGPO	$\overline{RI}$ $\overline{RI}$ (Pin 17), follows this bit when RIGPIOEN = 1 <sub>b</sub> .
3:1	Reserved	Reads returns to zero.
0	RIGPIOEN	<b>0 = <math>\overline{RI}</math> indicates valid ring signal. (Normal ring-indicator mode)</b> 1 = $\overline{RI}$ (Pin 17) can be used as a general purpose output and follows U7C[4] (RIGPO).

## U7D GEND

Bit	D15	D14	D13	D12	D11	D10	D9	D8	D7	D6	D5	D4	D3	D2	D1	D0
Name		NLM													ATZD	FDP
Type	R/W														R/W	R/W

Reset settings = 0x0000

Bit	Name	Function
15	Reserved	Reads returns to zero.
14	NLM	<b>0 = Enables “No Loop Current” detect.</b> 1 = Disables “No Loop Current” detect.
13:2	Reserved	Reads returns to zero.
1	ATZD	<b>ATZ Disable.</b> <b>0 = ATZ functions normally.</b> 1 = Disable ATZ command.
0	FDP	<b>FSK Data Processing.</b> <b>0 = FSK data processing stops when carrier is lost.</b> 1 = FSK data processing continued for 2 bytes after carrier is lost.

## U87 SAM

Bit	D15	D14	D13	D12	D11	D10	D9	D8	D7	D6	D5	D4	D3	D2	D1	D0
Name						MINT	SERM	FSMS	XMTT[7:0]							
Type	R/W						R/W	R/W	R/W							

Reset settings = 0x0000

Bit	Name	Function
15:11	Reserved	Reads returns to zero.
10	MINT	<p><b>Minimal Transparency</b></p> <p><b>0 = Generates two-byte &lt;EM&gt; transparency sequences.</b> This option will use codes &lt;EM&gt;&lt;T5&gt; through &lt;EM&gt;&lt;T20&gt;, if possible, for received data containing two back-to-back bytes requiring transparency.</p> <p><b>1 = Generates one-byte &lt;EM&gt; transparency sequences.</b> This option will only use codes &lt;EM&gt;&lt;T1&gt; through &lt;EM&gt;&lt;T4&gt; for received data.</p>
9	SERM	<p><b>Special Error Reporting Mode</b></p> <p><b>0 = Ignore unrecognized in-band commands.</b></p> <p><b>1 = Generate &lt;EM&gt;&lt;0x45&gt; ("E" for error) in response to any unrecognized in-band commands.</b></p>
8	FSMS	<p><b>Framed Sub-Mode Startup</b></p> <p><b>0 = Upon successful connection, enter Transport Sub-Mode.</b> An &lt;EM&gt;&lt;FLAG&gt; is required to enter Framed Sub-Mode.</p> <p><b>1 = Upon successful connection, immediately enter Framed Sub-Mode.</b> The first received &lt;EM&gt;&lt;err&gt; from a successful hunt is transformed into an &lt;EM&gt;&lt;flag&gt;.</p>
7:0	XMTT	<p><b>Transmitter Threshold</b></p> <p>This value represents the number of bytes before a transmission is started.</p> <p>The following values are special:</p> <p>0     The same as ten. Upon receipt of ten bytes, data is transferred. The DTE must supply a closing flag within the required time or an underrun will occur.</p> <p>255   The same as infinity, e.g. never start a packet until the closing flag is received.</p>

## 7. Parallel Interface Registers

### Parallel Interface 0 (0x00)

Bit	D7	D6	D5	D4	D3	D2	D1	D0
Name	TX/RX[7:0]							
Type	R/W							

Reset settings = 0x00

Bit	Name	Function
7:0	TX/RX[7:0]	<b>Parallel Interface Transmit/Receive.</b> This register functions similarly to the serial port TX pin on writes to the parallel port, and similarly to the serial port RX pin on reads from the parallel port.

Confidential

**Parallel Interface 1 (0x01)**

Bit	D7	D6	D5	D4	D3	D2	D1	D0
Name	RXF	TXE	REM	INTM	INT	ESC	$\overline{\text{RTS}}$	$\overline{\text{CTS}}$
Type	R	R	R	R/W	R	R/W	R/W	R

Reset settings = 0110\_0011

Bit	Name	Function
7	RXF	<b>Receive FIFO Almost Full (status).</b> 0 = Receive FIFO (12 deep) contains three or more empty locations ( $\text{RXF} \leq 9$ ). The host can clear the RXF interrupt without emptying the RX FIFO by writing a 0 to the RXF bit. This will disable the RXF interrupt until the host has emptied the FIFO. 1 = Receive FIFO contains two or less empty locations ( $\text{RXF} \geq 10$ ).
6	TXE	<b>Transmit FIFO Almost Empty (status).</b> 0 = Transmit FIFO (14 deep) contains three or more characters ( $\text{TXF} \geq 3$ ). 1 = Transmit FIFO contains two or less characters ( $\text{TXF} \leq 2$ ). <b>Note:</b> TXE interrupt will not trigger if the CTS bit is inactive. Therefore, the host does not need to poll CTS while waiting for transmit FIFO to empty. TXE can be cleared by writing it to 0.
5	REM	<b>Receive FIFO Empty.</b> 0 = Receive FIFO has valid data. 1 = Receive FIFO empty. <b>Note:</b> If the interim timer (see PTMR - U6F, bits 7:0) set by PTMR expires, it will cause an interrupt. This interrupt will not set RXF, TXE, or INT. The interrupt handler on the host should then verify that $\text{REM} = 0$ and begin to empty the receive FIFO (Parallel Interface 0 register) until $\text{REM} = 1$ .
4	INTM	<b>Interrupt Mask.</b> 0 = In parallel mode, the $\overline{\text{INT}}$ pin is triggered by a rising edge on RXF or TXE only (default). 1 = In parallel mode, the $\overline{\text{INT}}$ pin is triggered by a rising edge on RXF, TXE, or INT.
3	INT	<b>Interrupt.</b> 0 = No interrupt has occurred. 1 = Indicates that an interrupt (CID, OCD, PPD, RI, or DCD from U70) has occurred. This bit is cleared via the AT:I command.
2	ESC	<b>Escape.</b> Operation of this bit in parallel mode is functionally equivalent to the ESC pin in serial mode.
1	$\overline{\text{RTS}}$	<b>Request-to-Send.</b> Operation of this bit in parallel mode is functionally equivalent to the $\overline{\text{RTS}}$ pin in serial mode. Use of the $\overline{\text{CTS}}$ and $\overline{\text{RTS}}$ bits (as opposed to the TXE and RXF bits) allows the flow control between the host and the ISModem® to operate 1 byte at a time, rather than in blocks.
0	$\overline{\text{CTS}}$	<b>Clear-to-Send.</b> Operation of this bit in parallel mode is functionally equivalent to the $\overline{\text{CTS}}$ pin in serial mode. Use of the $\overline{\text{CTS}}$ and $\overline{\text{RTS}}$ bits (as opposed to the TXE and RXF bits) allows the flow control between the host and the ISModem to operate 1 byte at a time, rather than in blocks.

# Si2435/Si2417

## 8. Pin Descriptions: Si2435/17

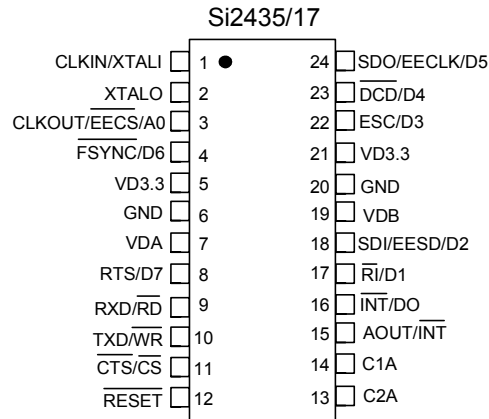

Pin #	Pin Name	Description
1	CLKIN/XTALI	<b>Clock Input/Crystal Oscillator Pin.</b> This pin provides support for parallel-resonant, AT cut crystals. XTALI also acts as an input in the event that an external clock source is used in place of a crystal. A 4.9152 MHz crystal or 4.9152/27 MHz clock is required.
2	XTALO	<b>Crystal Oscillator Pin.</b> This pin provides support for parallel-resonant AT-cut crystals. XTALO serves as the output of the crystal amplifier.
3	CLKOUT/A0	<b>Clock Output/Address Bit 0.</b> Clock output in serial mode. Address Enable in parallel mode.
4	FSYNC/D6	<b>Frame Sync/Data Bit.</b> Frame Sync output to codec in serial mode. Bidirectional parallel bus data bit 6 in parallel mode.
5, 21	VD3.3	<b>Digital Supply Voltage.</b> Provides the 3.3 V digital supply voltage to the Si2435/17.
6, 20	GND	<b>Ground.</b> Connects to the system digital ground.
7, 19	VDA, VDB	<b>Digital Rail.</b> Pin provides additional power supply voltage to the Si2435/17.
8	RTS/D7	<b>Request-to-Send/Data Bit.</b> Request-to-send (for flow control) in serial mode. Bidirectional parallel bus data bit 7 in parallel mode.
9	RXD/RD	<b>Receive Data/Read Enable.</b> Data output to DTE RXD pin in serial mode. Active low read enable pin in parallel mode.

Pin #	Pin Name	Description
10	TXD/ $\overline{\text{WR}}$	<b>Transmit Data/Write Enable.</b> Data input from DTE TXD pin in serial mode. Active low write enable pin in parallel mode.
11	$\overline{\text{CTS}}/\overline{\text{CS}}$	<b>Clear-to-Send/Chip Select.</b> Active low clear-to-send (for flow control) in serial mode. Active low chip select in parallel mode.
12	$\overline{\text{RESET}}$	<b>Reset Input.</b> An active low input that is used to reset all control registers to a defined initialized state.
13	C2A	<b>Isolation Capacitor 2A.</b> Connects to one side of the isolation capacitor, C2.
14	C1A	<b>Isolation Capacitor 1A.</b> Connects to one side of the isolation capacitor, C1.
15	AOUT/ $\overline{\text{INT}}$	<b>Analog Output/Interrupt Output.</b> Analog output in serial mode. Active low interrupt output in parallel mode.
16	$\overline{\text{INT}}/\text{D0}$	<b>Interrupt Output/Data Bit.</b> Active low interrupt output in serial mode. Bidirectional parallel bus data bit 0 in parallel mode.
17	$\overline{\text{RI}}/\text{D1}$	<b>Ring Indicator/Data Bit.</b> The $\overline{\text{RI}}$ on (active low) indicates the presence of an ON segment of a ring signal on the telephone line. Bidirectional parallel bus data bit 1 in parallel mode.
18	SDI/D2	<b>Serial Data In/Data Bit.</b> Serial Data In (to codec) output in serial mode. Bidirectional parallel bus data bit 2 in parallel mode.
22	ESC/D3	<b>Escape/Data Bit.</b> Hardware escape in serial mode. Bidirectional parallel bus data bit 3 in parallel mode.
23	$\overline{\text{DCD}}/\text{D4}$	<b>Carrier Detect/Data Bit.</b> Active low carrier detect in serial mode. Bidirectional parallel bus data bit 4 in parallel mode.
24	SDO/D5	<b>Serial Data Out/Data Bit 5.</b> Serial Data Out (from codec) input in serial mode. Bidirectional parallel bus data bit 5 in parallel mode.

## 9. Pin Descriptions: Si3018

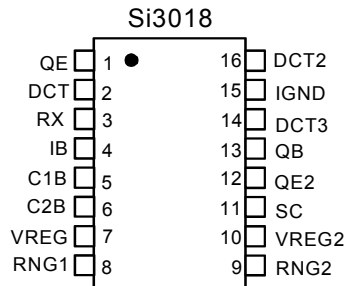

**Table 16. Si3018 Pin Descriptions**

Pin #	Pin Name	Description
1	QE	<b>Transistor Emitter.</b> Connects to the emitter of Q3.
2	DCT	<b>DC Termination.</b> Provides dc termination to the telephone network.
3	RX	<b>Receive Input.</b> Serves as the receive side input from the telephone network.
4	IB	<b>Internal Bias.</b> Provides a bias voltage to the device.
5	C1B	<b>Isolation Capacitor 1B.</b> Connects to one side of isolation capacitor C1 and communicates with the Si2435/17.
6	C2B	<b>Isolation Capacitor 2B.</b> Connects to one side of isolation capacitor C2 and communicates with the Si2435/17.
7	VREG	<b>Voltage Regulator.</b> Connects to an external capacitor to provide bypassing for an internal power supply.
8	RNG1	<b>Ring 1.</b> Connects through a resistor to the RING lead of the telephone line. Provides the ring and caller ID signals to the Si2435/17.
9	RNG2	<b>Ring 2.</b> Connects through a resistor to the TIP lead of the telephone line. Provides the ring and caller ID signals to the Si2435/17.
10	VREG2	<b>Voltage Regulator 2.</b> Connects to an external capacitor to provide bypassing for an internal power supply.
11	SC	<b>SC Connection.</b> Enables external transistor network. Should be tied through a 0 Ω resistor to I <sub>GND</sub> .
12	QE2	<b>Transistor Emitter 2.</b> Connects to the emitter of Q4.
13	QB	<b>Transistor Base.</b> Connects to the base of transistor Q4.
14	DCT3	<b>DC Termination 3.</b> Provides the dc termination to the telephone network.
15	IGND	<b>Isolated Ground.</b> Connects to ground on the line-side interface.
16	DCT2	<b>DC Termination 2.</b> Provides dc termination to the telephone network.

10. Ordering Guide<sup>1,2</sup>

System Side			
Part Number	Package	Lead-Free	Temp Range
Si2435-X-FT	TSSOP-24	Yes	0 to 70 °C
Si2417-X-FT	TSSOP-24	Yes	0 to 70 °C
Line Side			
Part Number	Package	Lead-Free	Temp Range
Si3018-X-FS	SOIC-16	Yes	0 to 70 °C
<b>Notes:</b>			
1. "X" denotes product revision.			
2. Add an "R" at the end of the device to denote tape and reel option; 2500 quantity per reel.			

Confidential

## 11. Package Outline: 24-Pin TSSOP

Figure 5 illustrates the package details for the Si2435/17. Table 17 lists the values for the dimensions shown in the illustration.

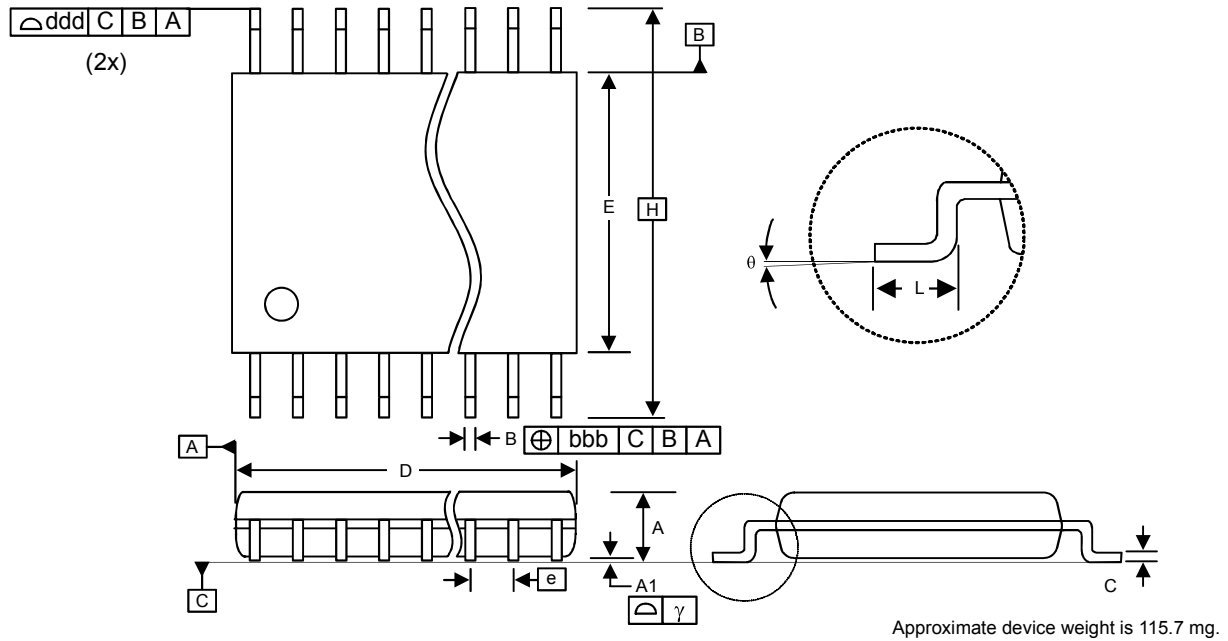

Figure 5. 24-Pin Thin Shrink Small Outline Package (TSSOP)

Table 17. Package Diagram Dimensions

Symbol	Millimeters	
	Min	Max
A	—	1.20
A1	0.05	0.15
B	0.19	0.30
C	0.09	0.20
D	7.70	7.90
E	4.30	4.50
e	0.65 BSC	
H	6.40 BSC	
L	0.45	0.75
$\theta$	0°	8°
$\gamma$	0.10	
bbb	0.10	
ddd	0.20	

## 12. Package Outline: 16-Pin SOIC

Figure 6 illustrates the package details for the Si3018. Table 18 lists the values for the dimensions shown in the illustration.

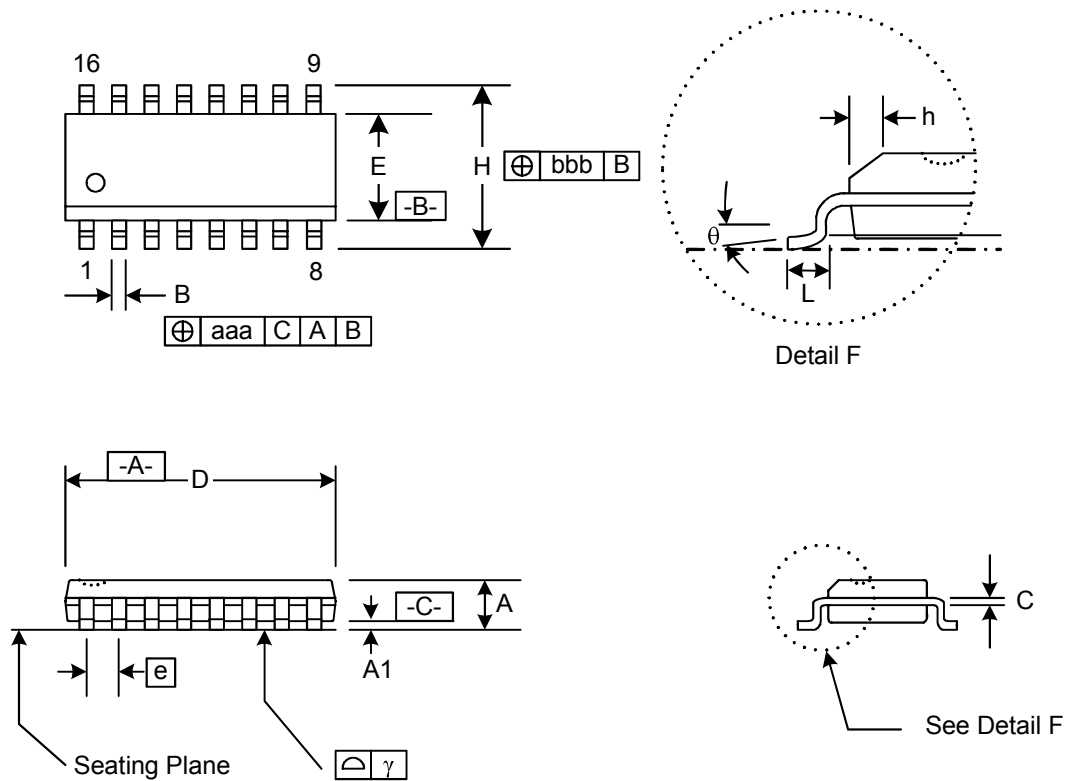

Figure 6. 16-pin Small Outline Integrated Circuit (SOIC) Package

Table 18. Package Diagram Dimensions

Symbol	Millimeters	
	Min	Max
A	1.35	1.75
A1	.10	.25
B	.33	.51
C	.19	.25
D	9.80	10.00
E	3.80	4.00
e	1.27 BSC	
H	5.80	6.20
h	.25	.50
L	.40	1.27
$\gamma$	0.10	
$\theta$	0°	8°
aaa	0.25	
bbb	0.25	

## CONTACT INFORMATION

### Silicon Laboratories Inc.

4635 Boston Lane  
Austin, TX 78735  
Tel: 1+(512) 416-8500  
Fax: 1+(512) 416-9669  
Toll Free: 1+(877) 444-3032  
Email: ISOinfo@silabs.com  
Internet: www.silabs.com

Confidential

The information in this document is believed to be accurate in all respects at the time of publication but is subject to change without notice. Silicon Laboratories assumes no responsibility for errors and omissions, and disclaims responsibility for any consequences resulting from the use of information included herein. Additionally, Silicon Laboratories assumes no responsibility for the functioning of undescribed features or parameters. Silicon Laboratories reserves the right to make changes without further notice. Silicon Laboratories makes no warranty, representation or guarantee regarding the suitability of its products for any particular purpose, nor does Silicon Laboratories assume any liability arising out of the application or use of any product or circuit, and specifically disclaims any and all liability, including without limitation consequential or incidental damages. Silicon Laboratories products are not designed, intended, or authorized for use in applications intended to support or sustain life, or for any other application in which the failure of the Silicon Laboratories product could create a situation where personal injury or death may occur. Should Buyer purchase or use Silicon Laboratories products for any such unintended or unauthorized application, Buyer shall indemnify and hold Silicon Laboratories harmless against all claims and damages.

Silicon Laboratories, Silicon Labs, and ISModem are registered trademarks of Silicon Laboratories Inc.  
Other products or brandnames mentioned herein are trademarks or registered trademarks of their respective holders.

## Looking for pricing, stock, or lifecycle information?

Click below to explore more details on WIN SOURCE:

- [View SI2435-A-FT on WIN SOURCE](#)
- [Skyworks Solutions Inc. Information](#)

## Optimize Your Supply Chain with WIN SOURCE Solutions

- ✓ Global Sourcing Solution
- ✓ Obsolete Management
- ✓ Cost Control Management
- ✓ Shortage Management
- ✓ Alternative Solution
- ✓ Excess Inventory Management