



**THE DATASHEET OF
CYUSB3314-88LTXC**



General Description

HX3 is a family of USB 3.0 hub controllers compliant with the USB 3.0 specification revision 1.0. HX3 supports SuperSpeed (SS), Hi-Speed (HS), Full-Speed (FS), and Low-Speed (LS) on all the ports. It has integrated termination, pull-up, and pull-down resistors, and supports configuration options through pin-straps to reduce the overall BOM of the system.

HX3 includes the following Cypress-proprietary features:

Shared Link™: Enables extra downstream (DS) ports for on-board connections in embedded applications

Ghost Charge™: Enables charging of devices connected to the DS ports when no host is connected on the upstream (US) port

Features

- USB-IF Certified Hub, TID# 330000060, 30000074
- Supports up to Four USB 3.0-Compliant DS ports
 - All ports support SS (5 Gbps), and are backward-compatible with HS (480 Mbps), FS (12 Mbps), and LS (1.5 Mbps)
 - SS and USB 2.0 Link Power Management (LPM)
 - Dedicated Hi-Speed Transaction Translators (Multi-TT)
 - LED status indicators – suspend, SS, and USB 2.0 operation
- Shared Link™ for Embedded Applications
 - Each DS port can simultaneously connect to an embedded SS device and a removable USB 2.0 device
 - Enables up to eight device connections
- Enhanced Battery Charging
 - Each DS port complies with the USB Battery Charging v1.2 (BC v1.2) specification
 - Ghost Charge™: Each DS port can emulate a Dedicated Charging Port (DCP) when the host is not connected to the US port
 - Accessory Charger Adapter Dock (ACA-Dock): Enables charging and simultaneous data transfer for a smart phone or a tablet acting as a host compliant to BC v1.2
 - Apple charging supported on all DS ports
- Integrated ARM® Cortex™-M0 CPU
 - 16 KB RAM, 32 KB ROM
 - Configure GPIOs for overcurrent protection, power enable, and LEDs
 - Upgrade firmware using (a) I²C EEPROM or (b) an external I²C master
- Vendor-Command Support to Implement a USB-to-I²C Bridge
 - Firmware upgrade of an external ASSP connected to HX3 through USB
 - In-System Programming (ISP) of the EEPROM connected to HX3 through USB
- Extensive Configuration Support
 - Pin-strap configuration for the following functions:
 - Vendor ID (VID)
 - Charging support for each DS port
 - Number of active ports
 - Number of non-removable devices
 - Ganged or individual power switch enables for DS ports
 - Power switch polarity selection
 - Custom configuration modes supported with eFuse, I²C EEPROM, or I²C slave
 - SS and USB 2.0 PHY parameters
 - Product ID (PID)/VID, manufacturer, and product string descriptors
 - Swap DP/DM signals for flexible PCB routing
- Software Features
 - Microsoft WHQL-certified for Windows XP/Vista/7/8/8.1
 - Compatible with Mac OS 10.9 and Linux kernel version 3.11
 - Customize configuration parameters with the easy-to-use Cypress's "Blaster Plus" software tool
- Flexible Packaging Options
 - 68-pin QFN (8 × 8 × 1.0 mm)
 - 88-pin QFN (10 × 10 × 1.0 mm)
 - 100-ball BGA (6 × 6 × 1.0 mm)
 - Industrial temperature range (–40 °C to +85 °C)

Block Diagram

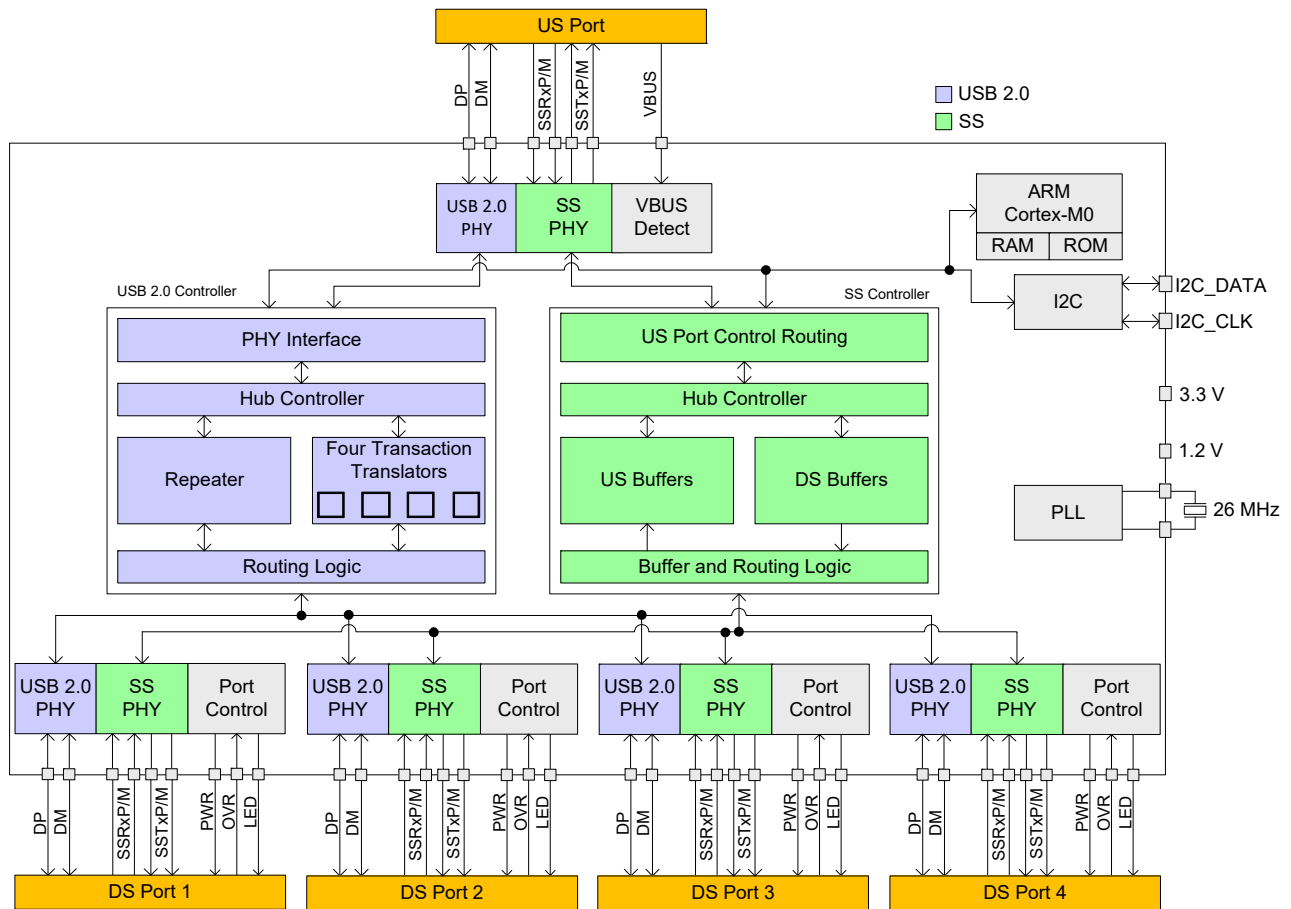

Contents

Architecture Overview	4	EMI	33
SS Hub Controller	4	ESD	33
USB 2.0 Hub Controller	4	Absolute Maximum Ratings	34
CPU	4	Electrical Specifications	34
I2C Interface	4	DC Electrical Characteristics	34
Port Controller	4	Power Consumption	35
Applications	4	Ordering Information	36
HX3 Product Options	5	Ordering Code Definitions	37
Product Features	6	Packaging	38
Shared Link	6	Package Diagrams	39
Ghost Charge	6	Acronyms	41
Vendor-Command Support	7	Reference Documents	41
ACA-Dock Support	7	Document Conventions	41
Pin Information	8	Units of Measure	41
System Interfaces	24	Silicon Revision History	42
Upstream Port (US)	24	Method of Identification	42
Downstream Ports (DS1, 2, 3, 4)	24	Document History Page	43
Communication Interfaces (I2C)	24	Sales, Solutions, and Legal Information	45
Oscillator	24	Worldwide Sales and Design Support	45
GPIOs	24	Products	45
Power Control	24	PSoC® Solutions	45
Reset	24	Cypress Developer Community	45
Configuration Mode Select	24	Technical Support	45
Configuration Options	25		

Architecture Overview

The [Block Diagram on page 2](#) shows the HX3 architecture. HX3 consists of two independent hub controllers (SS and USB 2.0), the Cortex-M0 CPU subsystem, an I²C interface, and port controller blocks.

SS Hub Controller

This block supports the SS hub functionality based on the USB 3.0 specification. The SS hub controller supports the following:

- SS link power management (U0, U1, U2, U3 states)
- Full-duplex data transmission

USB 2.0 Hub Controller

This block supports the LS, FS, and HS hub functionalities. It includes the repeater, frame timer, and four transaction translators.

The USB 2.0 hub controller block supports the following:

- USB 2.0 link power management (L0, L1, L2, L3 states)
- Suspend, resume, and remote wake-up signaling
- Multi-TT (one TT for each DS port)

CPU

The ARM Cortex-M0 CPU subsystem is used for the following functions:

- System configuration and initialization
- Battery charging control
- Vendor-specific commands for the USB-to-I²C bridge
- String-descriptor support
- Suspend status indicator
- Shared Link support in embedded systems

I²C Interface

The I²C interface in HX3 supports the following:

- I²C Slave, Master, and Multi-master configurations
 - Configure HX3 by an external I²C master in I²C slave mode
 - Configure HX3 from an I²C EEPROM
 - Multi-master mode to share EEPROM with other I²C masters
- In-System Programming of the I²C EEPROM from HX3's US port

Port Controller

The port controller block controls DS port power to comply with the BC v1.2 and USB 3.0 specifications. This block also controls the US port power in the ACA-Dock mode. Control signals for external power switches are implemented within the chip. HX3 controls the external power switches at power-on to reduce in-rush current.

The port controller block supports the following:

- Overcurrent detection
- SS and USB 2.0 port indicators for each DS port
- Ganged and individual power control modes
- Automatic port numbering based on active ports

Applications

- Standalone hubs
- PC and tablet motherboards
- Docking station
- Hand-held cradles
- Monitors
- Digital TVs
- Set-top boxes
- Printers

HX3 Product Options

Table 1. HX3 Product Options

Features	CYUSB3302	CYUSB3304	CYUSB3312	CYUSB3314	CYUSB3324	CYUSB3326	CYUSB3328	CYUSB2302	CYUSB2304
Number of DS ports	2 (USB 3.0)	4 (USB 3.0)	2 (USB 3.0)	4 (USB 3.0)	4 (USB 3.0)	6 (2 USB 3.0, 2 SS, 2 USB 2.0)	8 (4 SS, 4 USB 2.0)	2 (USB 2.0)	4 (USB 2.0)
Number of Shared Link ports	0	0	0	0	0	2 ^[1]	4	0	0
BC v1.2	Yes	Yes	Yes	Yes	Yes	Yes	Yes	Yes	Yes
ACA-Dock	No	No	No	No	Yes	No	Yes	No	No
External Power Switch Control	Ganged	Ganged	Individual and Ganged	Individual and Ganged	Individual and Ganged	Individual	Individual	Ganged	Ganged
Pin-Strap support	No	No	Yes	Yes	Yes	Yes	Yes	No	No
I ² C	Yes	Yes	Yes	Yes	Yes	Yes	Yes	Yes	Yes
Vendor command	Yes	Yes	Yes	Yes	Yes	Yes	Yes	Yes	Yes
Port indicators	No	No	Yes	Yes	Yes	No	No	No	No
Packages ^[2]	68-QFN, 100-ball BGA	68-QFN, 100-ball BGA	88-QFN, 100-ball BGA	88-QFN, 100-ball BGA	88-QFN, 100-ball BGA	88-QFN, 100-ball BGA	88-QFN, 100-ball BGA	68-QFN, 100-ball BGA	68-QFN, 100-ball BGA
Temperature range	Industrial and Commercial	Industrial and Commercial	Industrial and Commercial	Industrial and Commercial	Industrial and Commercial	Industrial and Commercial	Industrial (88-QFN only) and Commercial	Industrial and Commercial	Industrial and Commercial

Notes

1. DS1 and DS2 are Shared link Ports.
2. BGA Industrial Grade packages are limited to 1 W of active power. For power calculations refer to [Table 12](#) on page 35.

Product Features

Shared Link

Figure 1. Application of Shared Link in a Notebook

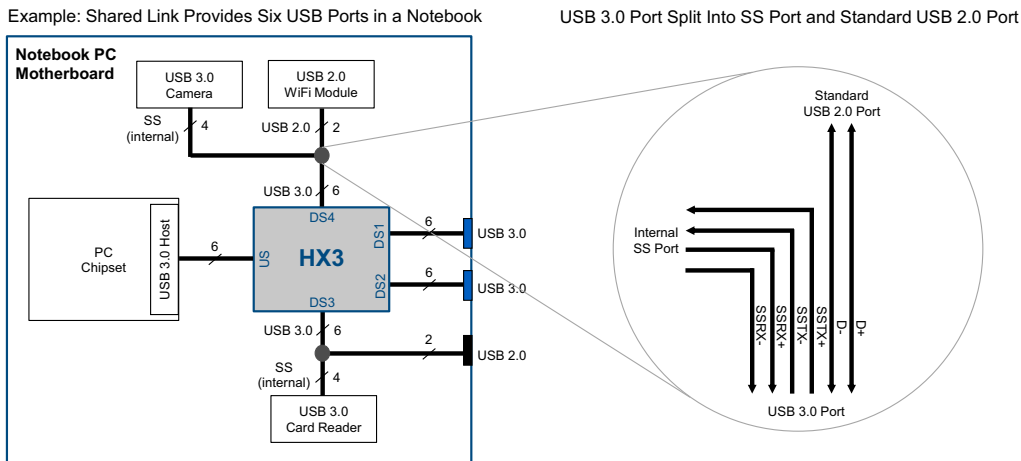

Shared Link is a Cypress-proprietary feature that enables a USB 3.0 port to be split into an embedded SS port and a standard USB 2.0 port. Shared Link enables a maximum of eight DS ports from a four-port USB 3.0 hub.

For example, if one of the DS ports is connected to an embedded SS device, such as a USB 3.0 camera, HX3 enables the system designer to reuse the USB 2.0 signals of that specific port to connect to a standard USB 2.0 port. Figure 1 shows how Shared Link can be used in an application.

DSx_PWREN is another output signal generated by HX3 and controls VBUS for the removable USB 2.0 device. For example, when an overcurrent condition occurs, DSx_PWREN turns off the port power.

Ghost Charge

Ghost Charge is a Cypress-proprietary feature for charging USB devices on the DS port when the US port is not connected to a host. For example, in a docking station with HX3 as shown in Figure 3, when the laptop is undocked, HX3 will emulate a dedicated charging port (DCP) to provide charge to a phone connected on a DS port.

Figure 2. DS Port VBUS Control in Shared Link

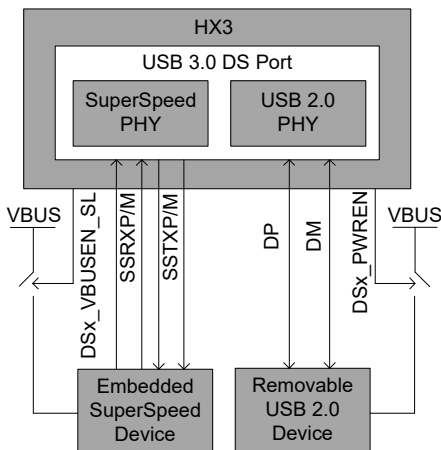

The Shared Link mode requires a separate VBUS control for the removable USB 2.0 device and the embedded SS device. Figure 2 shows the VBUS control implementation.

To ensure that the embedded SS device does not fall back to USB 2.0 operation, an external power switch is required. This switch is controlled by HX3, which generates an output signal called DSx_VBUSEN_SL. This signal controls the VBUS for the embedded device.

Figure 3. Ghost Charge



Charge a smartphone without docking the notebook

When the US port is disconnected from the host, HX3 detects if any of the DS ports are connected to a device requesting charging. It determines the charging method and then switches to the appropriate signaling based on the detected charging specification as shown in Figure 4. The hub either emulates a USB-compliant dedicated charging port by connecting DP and DM (see the BC v1.2 specification) or other supported proprietary charging schemes.

Figure 4. Ghost Charge Implementation in HX3

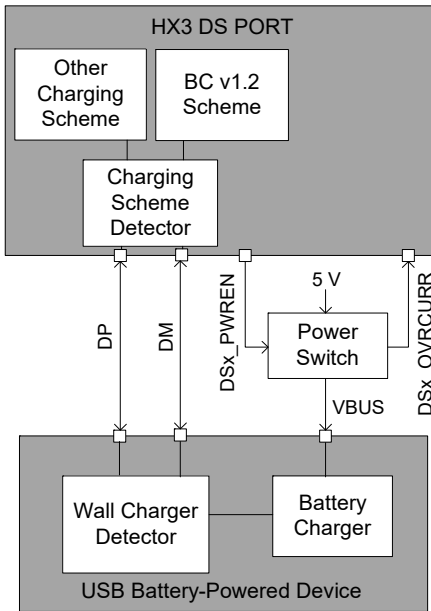

Ghost Charge is enabled by default and can be disabled through configuration. Refer to Configuration Options on page 25.

Vendor-Command Support

HX3 supports vendor-specific requests and can also enumerate as a vendor-specific device. The vendor-specific request can be used to (a) bridge USB and I²C and (b) configure HX3. This feature can be used for the following applications:

- Firmware upgrade of an external ASSP connected to HX3 through USB
- In-System programming (ISP) of an EEPROM connected to HX3 through USB

Note

3. 124 kΩ is the recommended RID_A value as per BC v1.2 specification, but some portable devices use custom RID_A values.

ACA-Dock Support

In traditional USB topologies, the host provides VBUS to enable and charge the connected devices. For OTG hosts, however, an ACA-Dock provides VBUS and a method to charge the host. HX3 supports the ACA-Dock standard (see BC v1.2 specification) by integrating the functions of the adapter controller.

Figure 5 shows the ACA-Dock system. If the ACA-Dock feature is enabled, HX3 turns on the external power switch to drive VBUS on the US port. To inform the OTG host that it is connected to an ACA-Dock, the ID pin is tied to ground using a resistor RID_A³ as shown in Figure 5. The ACA-Dock feature can be disabled using the Configuration Options on page 25.

For example, a BC v1.2 compliant phone such as a Sony Xperia (neo V) can be docked to a HX3-based ACA-Dock system. The phone acts as an OTG host and the ACA-Dock charges the phone connected to the US port while also powering the four DS ports.

Figure 5. ACA-Dock Support

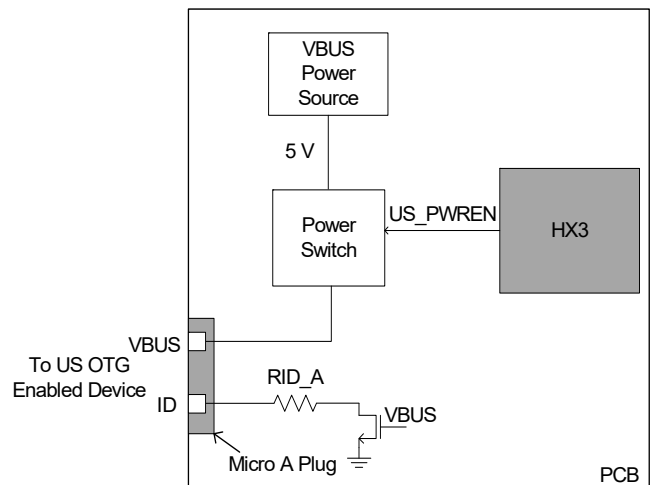

Pin Information

Figure 6. HX3 68-Pin QFN 2-Port Pinout

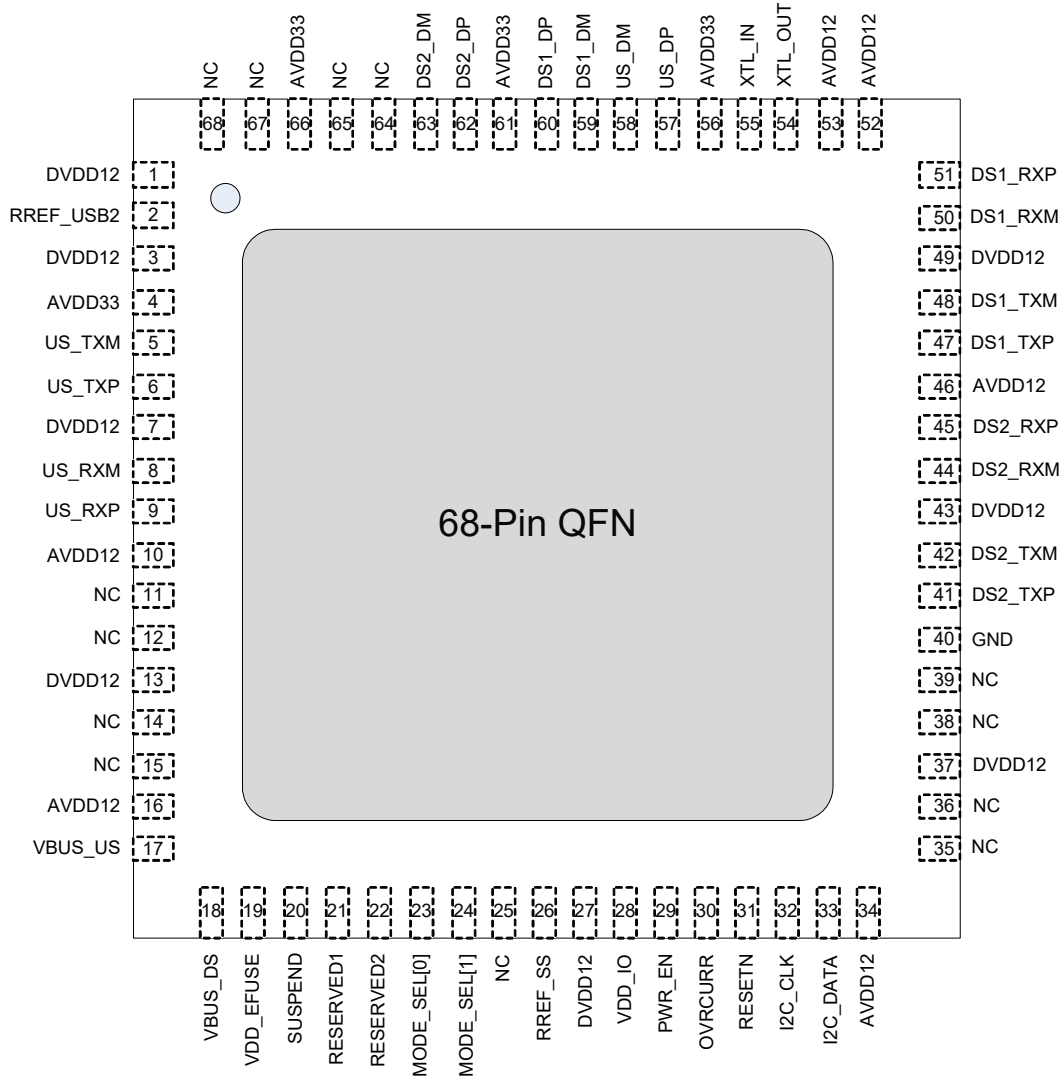

Figure 7. HX3 68-Pin QFN 4-Port Pinout

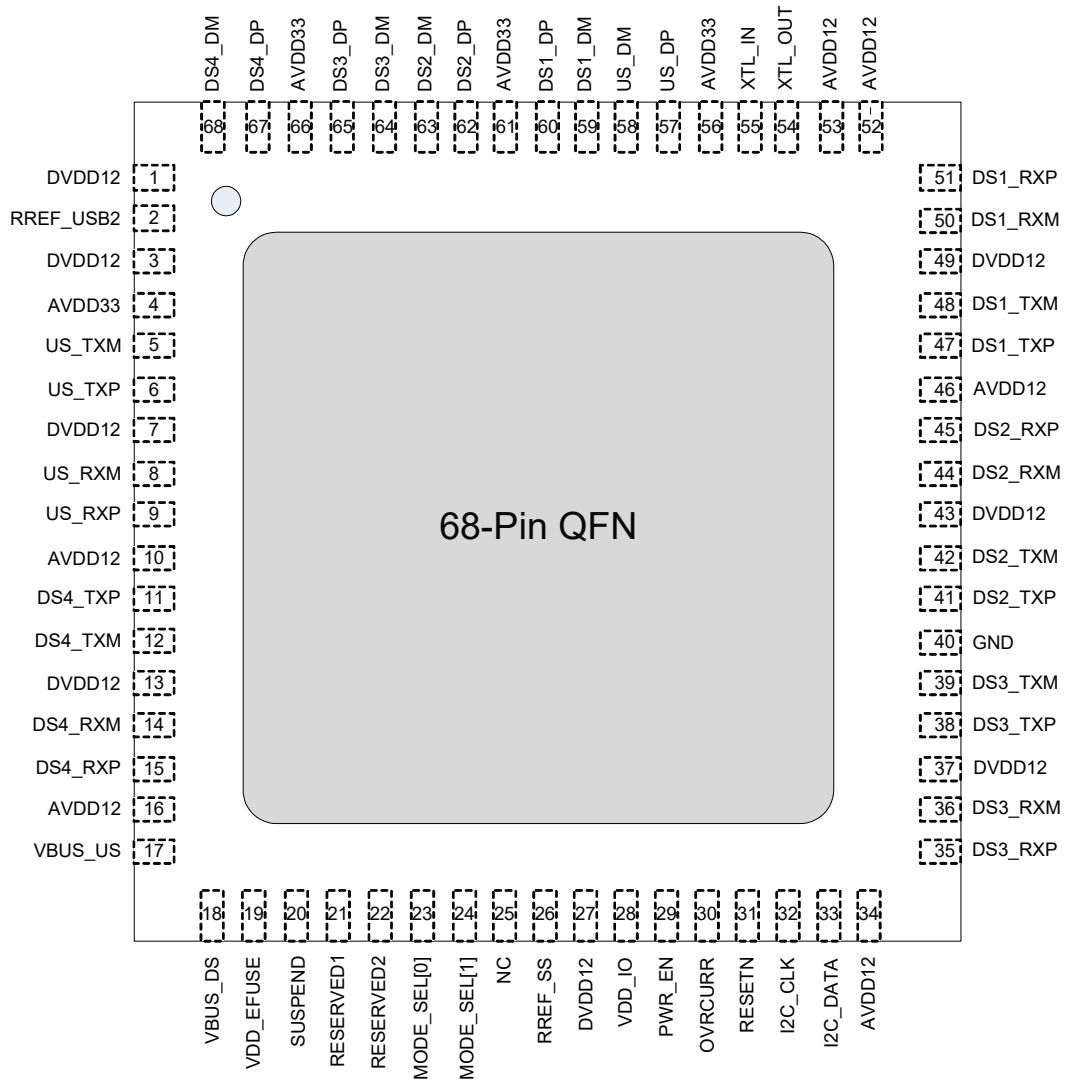

Figure 8. HX3 100-Ball BGA Pinout for CYUSB3302

A1	A2	A3	A4	A5	A6	A7	A8	A9	A10
NC	NC	NC	AVDD33	DS2_DM	DS2_DP	AVDD33	US_DM	US_DP	AVDD12
B1	B2	B3	B4	B5	B6	B7	B8	B9	B10
NC	NC	NC	VDD_IO	VSS	AVDD33	NC	NC	NC	DVDD12
C1	C2	C3	C4	C5	C6	C7	C8	C9	C10
US_TXM	NC	NC	NC	NC	VSS	DS1_DP	DS1_DM	AVDD12	DS1_RXM
D1	D2	D3	D4	D5	D6	D7	D8	D9	D10
US_TXP	NC	NC	DVDD12	VSS	DVDD12	VSS	DVDD12	VSS	DS1_RXP
E1	E2	E3	E4	E5	E6	E7	E8	E9	E10
DVDD12	RREF_US B2	NC	NC	XTL_IN	XTL_OUT	VDD_IO	DS1_TXM	VSS	DVDD12
F1	F2	F3	F4	F5	F6	F7	F8	F9	F10
US_RXM	VSS	AVDD33	MODE_SE L[1]	DVDD12	OVRCUR R	RESETN	DS1_TXP	AVDD12	DS2_RXP
G1	G2	G3	G4	G5	G6	G7	G8	G9	G10
US_RXP	VBUS_DS	SUSPEND	RESERVE D1	MODE_SE L[0]	VDD_IO	PWR_EN	I2C_DATA	VSS	DS2_RXM
H1	H2	H3	H4	H5	H6	H7	H8	H9	H10
AVDD12	VBUS_US	VDD_EFU SE	RESERVE D2	RREF_SS	VSS	DS2_TXM	DS2_TXP	NC	AVDD12
J1	J2	J3	J4	J5	J6	J7	J8	J9	J10
VSS	AVDD12	VSS	GPIO	NC	I2C_CLK	NC	NC	VSS	NC
K1	K2	K3	K4	K5	K6	K7	K8	K9	K10
NC	NC	DVDD12	NC	NC	NC	NC	NC	DVDD12	NC

Figure 9. HX3 100-Ball BGA Pinout for CYUSB3304

A1	A2	A3	A4	A5	A6	A7	A8	A9	A10
NC	DS4_DM	DS4_DP	AVDD33	DS2_DM	DS2_DP	AVDD33	US_DM	US_DP	AVDD12
B1	B2	B3	B4	B5	B6	B7	B8	B9	B10
NC	NC	NC	VDD_IO	VSS	AVDD33	NC	NC	NC	DVDD12
C1	C2	C3	C4	C5	C6	C7	C8	C9	10
US_TXM	NC	NC	DS3_DP	DS3_DM	VSS	DS1_DP	DS1_DM	AVDD12	DS1_RXM
D1	D2	D3	D4	D5	D6	D7	D8	D9	D10
US_TXP	NC	NC	DVDD12	VSS	DVDD12	VSS	DVDD12	VSS	DS1_RXP
E1	E2	E3	E4	E5	E6	E7	E8	E9	E10
DVDD12	RREF_US B2	NC	NC	XTL_IN	XTL_OUT	VDD_IO	DS1_TXM	VSS	DVDD12
F1	F2	F3	F4	F5	F6	F7	F8	F9	F10
US_RXM	VSS	AVDD33	MODE_SE L[1]	DVDD12	OVRCUR R	RESETN	DS1_TXP	AVDD12	DS2_RXP
G1	G2	G3	G4	G5	G6	G7	G8	G9	G10
US_RXP	VBUS_DS	SUSPEND	RESERVE D1	MODE_SE L[0]	VDD_IO	PWR_EN	I2C_DATA	VSS	DS2_RXM
H1	H2	H3	H4	H5	H6	H7	H8	H9	H10
AVDD12	VBUS_US	VDD_EFU SE	RESERVE D2	RREF_SS	VSS	DS2_TXM	DS2_TXP	NC	AVDD12
J1	J2	J3	J4	J5	J6	J7	J8	J9	J10
VSS	AVDD12	VSS	GPIO	NC	I2C_CLK	NC	NC	VSS	DS3_RXM
K1	K2	K3	K4	K5	K6	K7	K8	K9	K10
DS4_TXP	DS4_TXM	DVDD12	DS4_RXP	DS4_RXM	NC	DS3_TXP	DS3_TXM	DVDD12	DS3_RXP

Table 2. 68-Pin QFN, 100-Ball BGA Pinout for CYUSB3302 and CYUSB3304

Pin Name		Type	68-QFN Pin#	100-BGA Ball #	Description
CYUSB3302	CYUSB3304				
US Port					
	US_RXP	I	9	G1	SuperSpeed receive plus
	US_RXM	I	8	F1	SuperSpeed receive minus
	US_TXP	O	6	D1	SuperSpeed transmit plus
	US_TXM	O	5	C1	SuperSpeed transmit minus
	US_DP	I/O	57	A9	USB 2.0 data plus
	US_DM	I/O	58	A8	USB 2.0 data minus
DS1 Port					
	DS1_RXP	I	51	D10	SuperSpeed receive plus
	DS1_RXM	I	50	C10	SuperSpeed receive minus
	DS1_TXP	O	47	F8	SuperSpeed transmit plus
	DS1_TXM	O	48	E8	SuperSpeed transmit minus
	DS1_DP	I/O	60	C7	USB 2.0 data plus
	DS1_DM	I/O	59	C8	USB 2.0 data minus
DS2 Port					
	DS2_RXP	I	45	F10	SuperSpeed receive plus
	DS2_RXM	I	44	G10	SuperSpeed receive minus
	DS2_TXP	O	41	H8	SuperSpeed transmit plus
	DS2_TXM	O	42	H7	SuperSpeed transmit minus
	DS2_DP	I/O	62	A6	USB 2.0 data plus
	DS2_DM	I/O	63	A5	USB 2.0 data minus
DS3 Port					
NC	DS3_RXP	I	35	K10	SuperSpeed receive plus
NC	DS3_RXM	I	36	J10	SuperSpeed receive minus
NC	DS3_TXP	O	38	K7	SuperSpeed transmit plus
NC	DS3_TXM	O	39	K8	SuperSpeed transmit minus
NC	DS3_DP	I/O	65	C4	USB 2.0 data plus
NC	DS3_DM	I/O	64	C5	USB 2.0 data minus
DS4 Port					
NC	DS4_RXP	I	15	K4	SuperSpeed receive plus
NC	DS4_RXM	I	14	K5	SuperSpeed receive minus
NC	DS4_TXP	O	11	K1	SuperSpeed transmit plus
NC	DS4_TXM	O	12	K2	SuperSpeed transmit minus
NC	DS4_DP	I/O	67	A3	USB 2.0 data plus
NC	DS4_DM	I/O	68	A2	USB 2.0 data minus
	OVRCURR	I	30	F6	Ganged overcurrent input
	PWR_EN	I/O	29	G7	Ganged power enable output

Table 2. 68-Pin QFN, 100-Ball BGA Pinout for CYUSB3302 and CYUSB3304 (continued)

Pin Name		Type	68-QFN Pin#	100-BGA Ball #	Description
CYUSB3302	CYUSB3304				
NC		I/O	25	NA	NC
RESERVED1		I/O	21	G4	This pin must be pulled HIGH using a 10 k Ω to VDD_IO.
RESERVED2		I	22	H4	This pin must be pulled HIGH using a 10 k Ω to VDD_IO.
Mode Select, Clock, and Reset					
MODE_SEL[0]		I	23	G5	Device operation mode select bit 0; refer to Table 5 on page 24
MODE_SEL[1]		I	24	F4	Device operation mode select bit 1; refer to Table 5 on page 24
XTL_OUT		A	54	E6	Crystal out
XTL_IN		A	55	E5	Crystal in
RESETN		I	31	F7	Active LOW reset input
I2C_CLK		I/O	32	J6	I ² C clock
I2C_DATA		I/O	33	G8	I ² C data
SUSPEND		I/O	20	G3	Hub suspend status indicator. This pin is asserted if both the SS and USB 2.0 hubs are in the suspend state and is de-asserted when either of the hubs comes out of the suspend state.
Power and Ground					
VDD_EFUSE		PWR	19	H3	1.2 V normal operation, 2.5 V for programming. Customers should connect to 1.2 V.
AVDD12		PWR	10, 16, 34, 46, 52, 53	A10, C9, F9, H1, H10, J2	1.2 V analog supply
GND		PWR	40	B5, C6, D5, D7, D9, E9, F2, G9, H6, J1, J3, J9	GND pin
DVDD12		PWR	1, 3, 7, 13, 27, 37, 43, 49,	B10, D4, D6, D8, E1, E10, F5, K3, K9	1.2 V core supply
VBUS_US		PWR	17	H2	This pin must be connected to VBUS from US port
VBUS_DS		PWR	18	G2	This pin is used to power the Apple-charging circuit in HX3. For normal operation, connect pin to local 5 V supply to enable Apple charging and BC v1.2 charging modes (enable multi-charger mode). For BC v1.2 compliance testing or when Apple charging is not required, connect pin to GND to enable BC v1.2 charging mode (disable multi-charger mode).
AVDD33		PWR	4, 56, 61, 66	A4, A7, B6, F3	3.3 V analog supply
VDD_IO		PWR	28	B4, E7, G6	3.3 V I/O supply
USB Precision Resistors					
RREF_USB2		A	2	E2	Connect pin to a precision resistor (6.04 k Ω \pm 1%) to generate a current reference for USB 2.0 PHY.
RREF_SS		A	26	H5	Connect pin to a precision resistor (200 Ω \pm 1%) for SS PHY termination impedance calibration.

Note

4. These pins are Do Not Use (DNU); they must be left floating.

Table 3. 68-Pin QFN, 100-Ball BGA Pinout for CYUSB2302 and CYUSB2304

Pin Name		Type	68-QFN Pin#	100-BGA Ball #	Description
CYUSB2302	CYUSB2304				
US Port					
	NC	I	9	G1	SuperSpeed receive plus
	NC	I	8	F1	SuperSpeed receive minus
	NC	O	6	D1	SuperSpeed transmit plus
	NC	O	5	C1	SuperSpeed transmit minus
	US_DP	I/O	57	A9	USB 2.0 data plus
	US_DM	I/O	58	A8	USB 2.0 data minus
DS1 Port					
	NC	I	51	D10	SuperSpeed receive plus
	NC	I	50	C10	SuperSpeed receive minus
	NC	O	47	F8	SuperSpeed transmit plus
	NC	O	48	E8	SuperSpeed transmit minus
	DS1_DP	I/O	60	C7	USB 2.0 data plus
	DS1_DM	I/O	59	C8	USB 2.0 data minus
DS2 Port					
	NC	I	45	F10	SuperSpeed receive plus
	NC	I	44	G10	SuperSpeed receive minus
	NC	O	41	H8	SuperSpeed transmit plus
	NC	O	42	H7	SuperSpeed transmit minus
	DS2_DP	I/O	62	A6	USB 2.0 data plus
	DS2_DM	I/O	63	A5	USB 2.0 data minus
DS3 Port					
	NC	I	35	K10	SuperSpeed receive plus
	NC	I	36	J10	SuperSpeed receive minus
	NC	O	38	K7	SuperSpeed transmit plus
	NC	O	39	K8	SuperSpeed transmit minus
	NC	I/O	65	C4	USB 2.0 data plus
	NC	I/O	64	C5	USB 2.0 data minus
DS4 Port					
	NC	I	15	K4	SuperSpeed receive plus
	NC	I	14	K5	SuperSpeed receive minus
	NC	O	11	K1	SuperSpeed transmit plus
	NC	O	12	K2	SuperSpeed transmit minus
	NC	I/O	67	A3	USB 2.0 data plus
	NC	I/O	68	A2	USB 2.0 data minus
	OVRCURR	I	30	F6	Ganged overcurrent input
	PWR_EN	I/O	29	G7	Ganged power enable output

Table 3. 68-Pin QFN, 100-Ball BGA Pinout for CYUSB2302 and CYUSB2304 (continued)

Pin Name		Type	68-QFN Pin#	100-BGA Ball #	Description
CYUSB2302	CYUSB2304				
NC		I/O	25	NA	NC
RESERVED1		I/O	21	G4	This pin must be pulled HIGH using a 10 k Ω to VDD_IO.
RESERVED2		I	22	H4	This pin must be pulled HIGH using a 10 k Ω to VDD_IO.
Mode Select, Clock, and Reset					
MODE_SEL[0]		I	23	G5	Device operation mode select bit 0; refer to Table 5 on page 24
MODE_SEL[1]		I	24	F4	Device operation mode select bit 1; refer to Table 5 on page 24
XTL_OUT		A	54	E6	Crystal out
XTL_IN		A	55	E5	Crystal in
RESETN		I	31	F7	Active LOW reset input
I2C_CLK		I/O	32	J6	I ² C clock
I2C_DATA		I/O	33	G8	I ² C data
SUSPEND		I/O	20	G3	Hub suspend status indicator. This pin is asserted if both the SS and USB 2.0 hubs are in the suspend state and is de-asserted when either of the hubs comes out of the suspend state.
Power and Ground					
VDD_EFUSE		PWR	19	H3	1.2 V normal operation, 2.5 V for programming. Customers should connect to 1.2 V.
AVDD12		PWR	10, 16, 34, 46, 52, 53	A10, C9, F9, H1, H10, J2	1.2 V analog supply
GND		PWR	40	B5, C6, D5, D7, D9, E9, F2, G9, H6, J1, J3, J9	GND pin
DVDD12		PWR	1, 3, 7, 13, 27, 37, 43, 49,	B10, D4, D6, D8, E1, E10, F5, K3, K9	1.2 V core supply
VBUS_US		PWR	17	H2	This pin must be connected to VBUS from US port
VBUS_DS		PWR	18	G2	This pin is used to power the Apple-charging circuit in HX3. For normal operation, connect pin to local 5 V supply to enable Apple charging and BC v1.2 charging modes (enable multi-charger mode). For BC v1.2 compliance testing or when Apple charging is not required, connect pin to GND to enable BC v1.2 charging mode (disable multi-charger mode).
AVDD33		PWR	4, 56, 61, 66	A4, A7, B6, F3	3.3 V analog supply
VDD_IO		PWR	28	B4, E7, G6	3.3 V I/O supply
USB Precision Resistors					
RREF_USB2		A	2	E2	Connect pin to a precision resistor (6.04 k Ω \pm 1%) to generate a current reference for USB 2.0 PHY.
RREF_SS		A	26	H5	Connect pin to a precision resistor (200 Ω \pm 1%) for SS PHY termination impedance calibration.

Figure 10. HX3 88-Pin QFN 2-Port Pinout

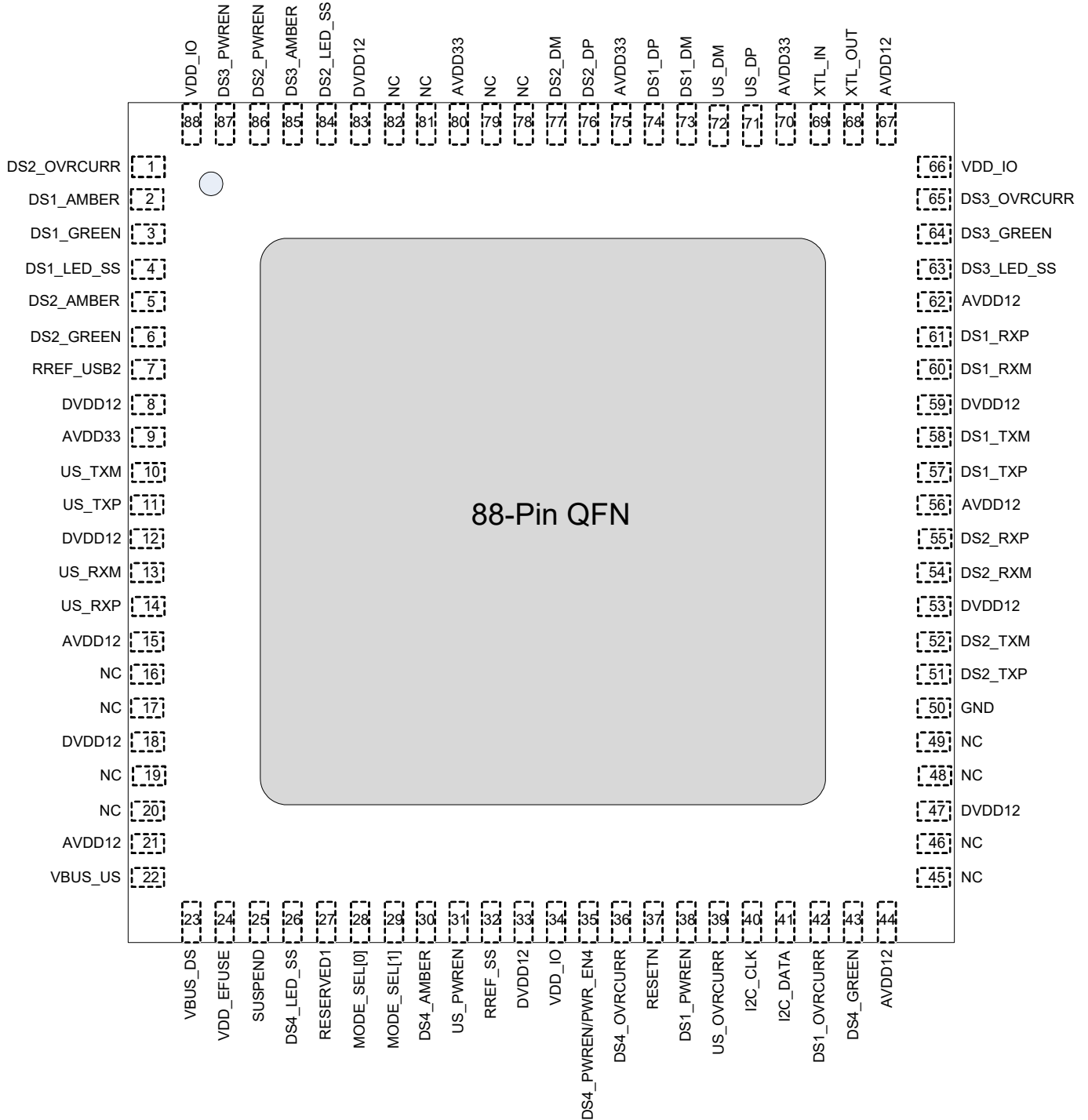

Figure 11. HX3 88-Pin QFN 4-Port Pinout

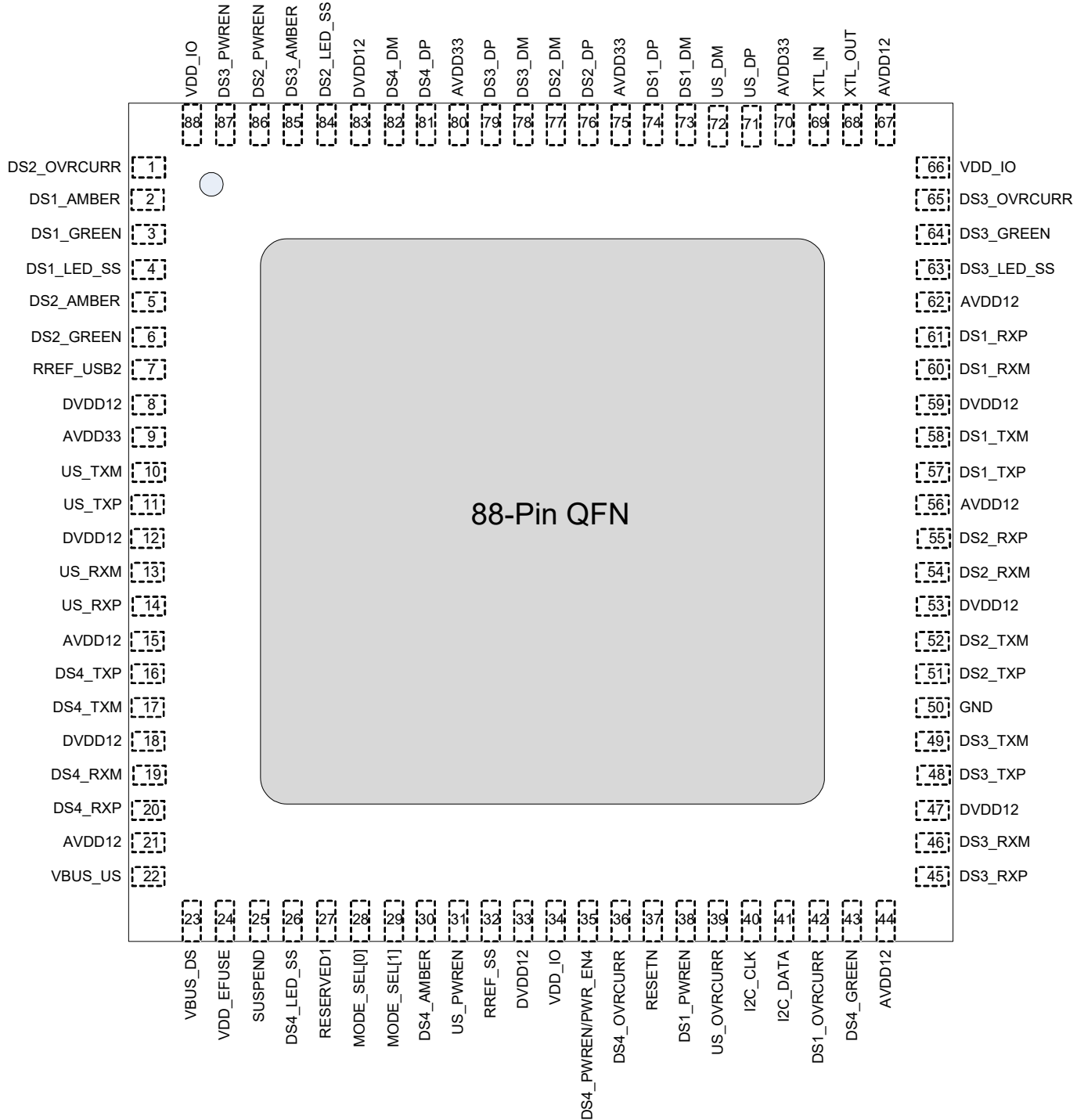

Figure 12. HX3 100-Ball BGA Pinout for CYUSB3312

A1	A2	A3	A4	A5	A6	A7	A8	A9	A10
DS3_PWR EN	NC	NC	AVDD33	DS2_DM	DS2_DP	AVDD33	US_DM	US_DP	AVDD12
B1	B2	B3	B4	B5	B6	B7	B8	B9	B10
DS2_OVR CURR	DS2_PWR EN	DS3_AMBE R	VDD_IO	VSS	AVDD33	DS3_OVR CURR	DS3_GREE N	DS3_LED_ SS	DVDD12
C1	C2	C3	C4	C5	C6	C7	C8	C9	C10
US_TXM	DS1_AMBE R	DS2_LED_ SS	NC	NC	VSS	DS1_DP	DS1_DM	AVDD12	DS1_RXM
D1	D2	D3	D4	D5	D6	D7	D8	D9	D10
US_TXP	DS1_LED_ SS	DS1_GREE N	DVDD12	VSS	DVDD12	VSS	DVDD12	VSS	DS1_RXP
E1	E2	E3	E4	E5	E6	E7	E8	E9	E10
DVDD12	RREF_USB 2	DS2_GREE N	DS2_AMBE R	XTL_IN	XTL_OUT	VDD_IO	DS1_TXM	VSS	DVDD12
F1	F2	F3	F4	F5	F6	F7	F8	F9	F10
US_RXM	VSS	AVDD33	MODE_SE L[1]	DVDD12	DS4_OVR CURR	RESETN	DS1_TXP	AVDD12	DS2_RXP
G1	G2	G3	G4	G5	G6	G7	G8	G9	G10
US_RXP	VBUS_DS	SUSPEND	RESERVE D1	MODE_SE L[0]	VDD_IO	DS4_PWR EN	I2C_DATA	VSS	DS2_RXM
H1	H2	H3	H4	H5	H6	H7	H8	H9	H10
AVDD12	VBUS_US	VDD_EFUS E	DS4_LED_ SS	RREF_SS	VSS	DS2_TXM	DS2_TXP	DS4_GREE N	AVDD12
J1	J2	J3	J4	J5	J6	J7	J8	J9	J10
VSS	AVDD12	VSS	DS4_AMBE R	US_PWRE N	I2C_CLK	DS1_PWR EN	DS1_OVR CURR	VSS	NC
K1	K2	K3	K4	K5	K6	K7	K8	K9	K10
NC	NC	DVDD12	NC	NC	US_OVRC URR	NC	NC	DVDD12	NC

Figure 13. HX3 100-Ball BGA Pinout for CYUSB3314, CYUSB332x

A1	A2	A3	A4	A5	A6	A7	A8	A9	A10
DS3_PWR EN	DS4_DM	DS4_DP	AVDD33	DS2_DM	DS2_DP	AVDD33	US_DM	US_DP	AVDD12
B1	B2	B3	B4	B5	B6	B7	B8	B9	B10
DS2_OVR CURR	DS2_PWR EN	DS3_AMB ER	VDD_IO	VSS	AVDD33	DS3_OVR CURR	DS3_GRE EN	DS3_LED _SS	DVDD12
C1	C2	C3	C4	C5	C6	C7	C8	C9	C10
US_TXM	DS1_AMB ER	DS2_LED _SS	DS3_DP	DS3_DM	VSS	DS1_DP	DS1_DM	AVDD12	DS1_RXM
D1	D2	D3	D4	D5	D6	D7	D8	D9	D10
US_TXP	DS1_LED _SS	DS1_GRE EN	DVDD12	VSS	DVDD12	VSS	DVDD12	VSS	DS1_RXP
E1	E2	E3	E4	E5	E6	E7	E8	E9	E10
DVDD12	RREF_US B2	DS2_GRE EN	DS2_AMB ER	XTL_IN	XTL_OUT	VDD_IO	DS1_TXM	VSS	DVDD12
F1	F2	F3	F4	F5	F6	F7	F8	F9	F10
US_RXM	VSS	AVDD33	MODE_SE L[1]	DVDD12	DS4_OVR CURR	RESETN	DS1_TXP	AVDD12	DS2_RXP
G1	G2	G3	G4	G5	G6	G7	G8	G9	G10
US_RXP	VBUS_DS	SUSPEND	RESERVE D1	MODE_SE L[0]	VDD_IO	DS4_PWR EN	I2C_DATA	VSS	DS2_RXM
H1	H2	H3	H4	H5	H6	H7	H8	H9	H10
AVDD12	VBUS_US	VDD_EFU SE	DS4_LED _SS	RREF_SS	VSS	DS2_TXM	DS2_TXP	DS4_GRE EN	AVDD12
J1	J2	J3	J4	J5	J6	J7	J8	J9	J10
VSS	AVDD12	VSS	DS4_AMB ER	US_PWR EN	I2C_CLK	DS1_PWR EN	DS1_OVR CURR	VSS	DS3_RXM
K1	K2	K3	K4	K5	K6	K7	K8	K9	K10
DS4_TXP	DS4_TXM	DVDD12	DS4_RXP	DS4_RXM	US_OVRC URR	DS3_TXP	DS3_TXM	DVDD12	DS3_RXP

Table 4. 88-Pin QFN, 100-Ball BGA Pinout for CYUSB331X and CYUSB332X

Pin Name		Type	Pin#	Ball#	Description
CYUSB3312	CYUSB3314				
	CYUSB3324				
	CYUSB3326				
	CYUSB3328				
US Port					
US_RXP	I	14	G1	SuperSpeed receive plus	
US_RXM	I	13	F1	SuperSpeed receive minus	
US_TXP	O	11	D1	SuperSpeed transmit plus	
US_TXM	O	10	C1	SuperSpeed transmit minus	
US_DP	I/O	71	A9	USB 2.0 data plus	
US_DM	I/O	72	A8	USB 2.0 data minus	
US_OVRCURR	I	39	K6	CYUSB3324/3328: Overcurrent detect input for US port in ACA-Dock mode. If ACA-Dock mode is disabled using Configuration Options on page 25 , this pin must be pulled HIGH using a 10 kΩ to VDD_IO. Other part numbers: This pin must be pulled HIGH using a 10 kΩ to VDD_IO.	
US_PWREN ^[5]	I/O	31	J5	CYUSB3324/3328: VBUS power enable output for US port in ACA-Dock mode. If ACA-Dock mode is disabled using Configuration Options on page 25 , this pin can be left floating if Pin-Strap is not enabled. Other part numbers: This pin can be left floating if Pin-Strap (Pin# 63) is not enabled.	
PWR_SW_POL ^[6]				This pin is called PWR_SW_POL in pin-strap configuration mode.	
DS1 Port					
DS1_RXP	I	61	D10	SuperSpeed receive plus	
DS1_RXM	I	60	C10	SuperSpeed receive minus	
DS1_TXP	O	57	F8	SuperSpeed transmit plus	
DS1_TXM	O	58	E8	SuperSpeed transmit minus	
DS1_DP	I/O	74	C7	USB 2.0 data plus	
DS1_DM	I/O	73	C8	USB 2.0 data minus	
DS1_OVRCURR	I	42	J8	Overcurrent detect input for DS1 port	
DS1_PWREN ^[5]	I/O	38	J7	VBUS power enable output for DS1 port. When the port is disabled, this pin is in tristate.	
DS1_CDP_EN ^[6]				This pin is called DS1_CDP_EN in pin-strap configuration mode.	
DS1_AMBER ^[5]	I/O	2	C2	LED_AMBER output for DS1 port	
ACA_DOCK ^[6]				This pin is called ACA-DOCK in pin-strap configuration mode.	
DS1_GREEN ^[5]	I/O	3	D3	CYUSB3312/3314/3324: LED_GREEN output for DS1 port	
DS1_VBUSEN_SL ^[5]				CYUSB3326/3328: VBUS power enable output for SS port 1	
PORT_DISABLE[0] ^[6]				This pin is called PORT_DISABLE[0] in pin-strap configuration mode.	
DS1_LED_SS ^[5]	I/O	4	D2	LED_SS output for DS1 port	
PORT_DISABLE[1] ^[6]				This pin is called PORT_DISABLE[1] in pin-strap configuration mode.	

Notes

- This pin can be configured as a GPIO using custom firmware. For information contact www.cypress.com/support.
- For pin-strap configuration details, refer to [Table 6](#) on page 26.

Table 4. 88-Pin QFN, 100-Ball BGA Pinout for CYUSB331X and CYUSB332X (continued)

Pin Name		Type	Pin#	Ball#	Description
CYUSB3312	CYUSB3314				
		CYUSB3324			
		CYUSB3326			
		CYUSB3328			
DS2 Port					
	DS2_RXP	I	55	F10	SuperSpeed receive plus
	DS2_RXM	I	54	G10	SuperSpeed receive minus
	DS2_TXP	O	51	H8	SuperSpeed transmit plus
	DS2_TXM	O	52	H7	SuperSpeed transmit minus
	DS2_DP	I/O	76	A6	USB 2.0 data plus
	DS2_DM	I/O	77	A5	USB 2.0 data minus
	DS2_OVRCURR	I	1	B1	Overcurrent detect input for DS2 port
	DS2_PWREN ^[7]	I/O	86	B2	VBUS power enable output for DS2 port. When the port is disabled, this pin is in tristate.
	DS2_CDP_EN ^[8]				This pin is called DS2_CDP_EN in the pin-strap configuration mode.
	DS2_AMBER ^[7]	I/O	5	E4	LED_AMBER output for DS2 port
	NON_REMOVABLE[0] ^[8]				This pin is called NON_REMOVABLE[0] in the pin-strap configuration mode.
	DS2_GREEN ^[7]	I/O	6	E3	CYUSB3312/3314/3324: LED_GREEN output for DS2 port
	DS2_VBUSEN_SL ^[7]				CYUSB3326/3328: VBUS power enable output for SS port 2
	NON_REMOVABLE[1] ^[8]				This pin is called NON_REMOVABLE[1] in the pin-strap configuration mode.
	DS2_LED_SS ^[7]	I/O	84	C3	LED_SS output for DS2 port
	PWR_EN_SEL ^[8]				This pin is called PWR_EN_SEL in the pin-strap configuration mode.
DS3 Port					
NC	DS3_RXP	I	45	K10	SuperSpeed receive plus
NC	DS3_RXM	I	46	J10	SuperSpeed receive minus
NC	DS3_TXP	O	48	K7	SuperSpeed transmit plus
NC	DS3_TXM	O	49	K8	SuperSpeed transmit minus
NC	DS3_DP	I/O	79	C4	USB 2.0 data plus
NC	DS3_DM	I/O	78	C5	USB 2.0 data minus
	DS3_OVRCURR	I	65	B7	CYUSB3314/3324/3326/3328: Overcurrent detect input for DS3 port CYUSB3312: This pin must be pulled HIGH using a 10 kΩ to VDD_IO.
	DS3_PWREN ^[7]	I/O	87	A1	VBUS power enable output for DS3 port. When the port is disabled, this pin is in tristate.
	DS3_CDP_EN ^[8]				This pin is called DS3_CDP_EN in the pin-strap configuration mode.
	DS3_AMBER ^[7]	I/O	85	B3	LED_AMBER output for DS3 port
	VID_SEL[2] ^[8]				This pin is called VID_SEL[2] in the pin-strap configuration mode.

Notes

7. This pin can be configured as a GPIO using custom firmware. For information contact www.cypress.com/support.
 8. For pin-strap configuration details, refer to [Table 6](#) on page 26.

Table 4. 88-Pin QFN, 100-Ball BGA Pinout for CYUSB331X and CYUSB332X (continued)

Pin Name		Type	Pin#	Ball#	Description
CYUSB3312	CYUSB3314				
	CYUSB3324				
	CYUSB3326				
	CYUSB3328				
DS3_GREEN ^[9]		I/O	64	B8	CYUSB3312/3314/3324: LED_GREEN output for DS3 port
DS3_VBUSEN_SL ^[9]					CYUSB3328: VBUS power enable output for SS port 3
VID_SEL[1] ^[10]					This pin is called VID_SEL[1] in the pin-strap configuration mode. For pin-strap configuration details, refer to Table 6 on page 26.
DS3_LED_SS ^[9]		I/O	63	B9	LED_SS output for DS3 port
PIN_STRAP ^[10]					This pin is called PIN_STRAP in pin-strap configuration mode. When connected to VDD_IO through a 10-kΩ resistor, this pin enables pin-strap configuration mode for HX3.
DS4 Port					
NC	DS4_RXP	I	20	K4	SuperSpeed receive plus
NC	DS4_RXM	I	19	K5	SuperSpeed receive minus
NC	DS4_TXP	O	16	K1	SuperSpeed transmit plus
NC	DS4_TXM	O	17	K2	SuperSpeed transmit minus
NC	DS4_DP	I/O	81	A3	USB 2.0 data plus
NC	DS4_DM	I/O	82	A2	USB 2.0 data minus
DS4_OVRCURR		I	36	F6	CYUSB3314/3324/3326/3328: Overcurrent detect input for DS4 port. CYUSB3312: This pin must be pulled HIGH using a 10 kΩ to VDD_IO.
DS4_PWREN/PWR_EN4		I/O	35	G7	VBUS power enable output for DS4 port. This pin is also used as power enable output when configured in ganged power mode using the Blaster Plus tool. When the port is disabled, this pin is in tristate.
DS4_CDP_EN ^[10]					This pin is called DS4_CDP_EN in the pin-strap configuration mode.
DS4_AMBER ^[9]		I/O	30	J4	LED_AMBER output for DS4 port
I2C_DEV_ID ^[10]					This pin is called I2C_DEV_ID in the pin-strap configuration mode.
DS4_GREEN ^[9]		I/O	43	H9	CYUSB3312/3314/3324: LED_GREEN output for DS4 port
DS4_VBUSEN_SL					CYUSB3328: VBUS power enable output for SS port 4
VID_SEL[0] ^[10]					This pin is called VID_SEL[0] in the pin-strap configuration mode.
DS4_LED_SS		I/O	26	H4	LED_SS output for DS4 port. The LED must be connected to GND as shown in Figure 16 on page 25. If LED is not used, this pin must be pulled HIGH using a 10 kΩ to VDD_IO.
RESERVED1		I	27	G4	This pin must be pulled HIGH using a 10 kΩ to VDD_IO.
Mode Select, Clock, and Reset					
MODE_SEL[0]		I	28	G5	Device operation mode select bit 0; refer to Table 5 on page 24
MODE_SEL[1]		I	29	F4	Device operation mode select bit 1; refer to Table 5 on page 24
XTL_OUT		A	68	E6	Crystal out
XTL_IN		A	69	E5	Crystal in
RESETN		I	37	F7	Active LOW reset input
I2C_CLK		I/O	40	J6	I ² C clock
I2C_DATA		I/O	41	G8	I ² C data

Notes

- 9. This pin can be configured as a GPIO using custom firmware. For information contact www.cypress.com/support.
- 10. For pin-strap configuration details, refer to [Table 6](#) on page 26.

Table 4. 88-Pin QFN, 100-Ball BGA Pinout for CYUSB331X and CYUSB332X (continued)

Pin Name		Type	Pin#	Ball#	Description
CYUSB3312	CYUSB3314				
	CYUSB3324				
	CYUSB3326				
	CYUSB3328				
SUSPEND		I/O	25	G3	Hub suspend status indicator. This pin is asserted if both the SS and USB 2.0 hubs are in the suspend state and is de-asserted when either of the hubs comes out of the suspend state.
Power and Ground					
VDD_EFUSE		PWR	24	H3	1.2 V normal operation, 2.5 V for programming. Customers should connect to 1.2 V
AVDD12		PWR	15, 21, 44, 56, 62, 67	A10, C9, F9, H1, H10, J2	1.2 V analog supply
GND		PWR	50	B5, C6, D5, D7, D9, E9, F2, G9, H6, J1, J3, J9	GND pin
DVDD12		PWR	8, 12, 18, 33, 47, 53, 59, 83	B10, D4, D6, D8, E1, E10, F5, K3, K9	1.2 V core supply
VBUS_US		PWR	22	H2	CYUSB3324/3328: Connect the VBUS_US pin to the local 5 V supply. If ACA-Dock mode is disabled using Configuration Options on page 25 , this pin must be connected to VBUS from US port. Other part numbers: This pin must be connected to VBUS from US port.
VBUS_DS		PWR	23	G2	This pin is used to power the Apple-charging circuit in HX3. For normal operation, connect pin to local 5 V supply to enable Apple charging and BC v1.2 charging modes (enable multi-charger mode). For BC v1.2 compliance testing or when Apple charging is not required, connect pin to GND to enable BC v1.2 charging mode (disable multi-charger mode).
AVDD33		PWR	9, 70, 75, 80	A4, A7, B6, F3	3.3 V analog supply
VDD_IO		PWR	34, 66, 88	B4, E7, G6	3.3 V I/O supply
USB Precision Resistors					
RREF_USB2		A	7	E2	Connect pin to a precision resistor (6.04 kΩ ±1%) to generate a current reference for USB 2.0 PHY.
RREF_SS		A	32	H5	Connect pin to a precision resistor (200 Ω ±1%) for SS PHY termination impedance calibration.

System Interfaces

Upstream Port (US)

This port is compliant with the USB 3.0 specification and includes an integrated 1.5 kΩ pull-up and termination resistors. It also supports ACA-Dock to enable charging an OTG host connected on the US port.

Downstream Ports (DS1, 2, 3, 4)

DS ports are compliant with the USB 3.0 specification and integrate 15 kΩ pull-down and termination resistors. Ports can be disabled or enabled, and can be set to removable or non-removable options. BC v1.2 charging is enabled by default and can be disabled on each DS port using the configuration options (see [Configuration Options](#)).

Communication Interfaces (I²C)

The interface follows the Inter-IC Bus specification, version 3.0, with support for the standard mode (100 kHz) and the fast mode (400 kHz) frequencies. HX3 supports I²C in the slave and master modes. The I²C interface supports the multi-master mode of operation. Both the SCL and SDA signals require external pull-up resistors based on the specification. VDD_IO for HX3 is 3.3 V and it is expected that the I²C pull-up resistors will be connected to the same supply.

Oscillator

HX3 requires an external crystal with a frequency of 26 MHz and an accuracy of ±150 ppm in parallel resonant, fundamental mode. The crystal drive circuit is capable of a low-power drive level (<200 μW). The crystal connection to the XTL_OUT and XTL_IN pins is shown in [Figure 14](#).

Figure 14. Crystal Connection

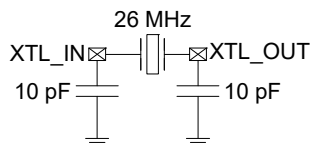

GPIOs

HX3 GPIOs are used for overcurrent sensing, controlling external power switches, and driving LEDs. These pins can sink up to 4 mA current each. GPIOs also enable pin-straps for input configuration. Refer to [Table 6](#) for more details.

Power Control

The PWR_EN[1-4] and OV_CURR[1-4] pins interface HX3 to external power switches. These pins are used to control power

switches for DS port power and monitor overcurrent conditions. The power switch polarity and the power control mode (individual and ganged) can be changed using the configuration options.

Reset

HX3 operates with two external power supplies, 3.3 V and 1.2 V. There is no power sequencing requirement between these two supplies. However, the RESETN pin should be held LOW until both these supplies become stable.

The RESETN pin can be tied to VDD_IO through an external resistor and to ground (GND) through an external capacitor (minimum 5 ms time constant), as shown in [Figure 15](#). This creates a clean reset signal for power-on reset (POR).

HX3 does not support internal brown-out detection. If the system requires this feature, an external reset should be provided on the RESETN pin when supplies are below their valid operating ranges.

Figure 15. Reset Connection

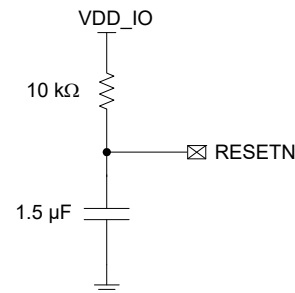

Configuration Mode Select

Configuration options are selected through the MODE_SEL pins and the pin-strap enable pin (PIN_STRAP). After power-up, these pins are sampled by an on-chip bootloader to determine the configuration options (see [Table 5](#)).

Table 5. HX3 Boot Sequence

MODE SEL[1]	MODE SEL[0]	HX3 Configuration Modes
0	0	Reserved. Do not use this mode.
1	1	Internal ROM configuration
0	1	I ² C Master, read configuration from I ² C EEPROM*
1	0	I ² C Slave, configure from an external I ² C Master*

* Download Cypress-provided firmware from www.cypress.com/hx3.

Configuration Options

HX3 can be configured by using one of the following:

- eFuse (one-time programmable memory)
- Pin-Strap (read configuration from dedicated pins at power on)
- External I²C slave such as an EEPROM
- External I²C master

The I²C master/slave configuration overrides the pin-strap configuration. Pin-straps override the eFuse configuration, and the eFuse configuration overrides the internal ROM configuration.

eFuse Configuration

HX3 contains eFuses, which are OTP elements on the chip that can be electrically blown. The eFuses are read by the bootloader to determine the customer-specific configurations. eFuse programming is supported only at factory and distributor locations where programming conditions can be controlled. eFuse programming is supported under the following conditions: Temperature range of 25 °C–70 °C and programming voltage of 2.5 V–2.7 V.

Pin-Strap Configuration

Pin-straps are supported for select product options (see [Table 1](#) on page 5) to provide reconfigurability without an additional EEPROM. The pin-strap configuration is enabled by pulling the Pin #63 of 88-pin QFN HIGH. [Table 6](#) on page 26 shows the configuration options supported through pin-straps and the GPIOs used for this purpose. [Figure 16](#) and [Figure 17](#) show how

the GPIOs need to be connected if pin-strap and LED connection are required or only pin-strap is required.

HX3 samples pin-strap GPIOs at power-up. Floating straps are considered as invalid and the default configuration is used. If PIN_STRAP (Pin #63 of 88-pin QFN) is floating, all strap inputs are considered invalid. A GPIO is considered strapped “1” or “0” when connected with a weak pull-up (10 kΩ) or pull-down (10 kΩ) respectively. After the initial sampling at power-up and reset, the GPIOs are used in their normal functions.

Figure 16. Pin-Strap With LED or LED-Only Connection

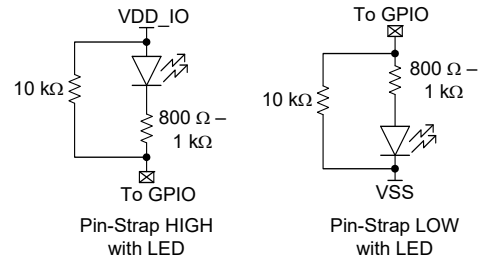

Figure 17. Pin-Strap Connection

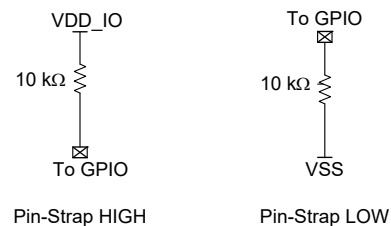

Table 6. Pin-Strap Configuration

88-pin QFN Pin #	Pin-Strap Name	Strapped '0' ^[11]		Strapped '1' ^[11]	
30	I2C_DEV_ID ^[12]	ID 0: HX3 I ² C slave address (7 bits) is 0x60. This is also the default I ² C slave address for the 68-pin QFN package.		ID 1: HX3 I ² C slave address (7 bits) is 0x58	
31	PWR_SW_POL	Power enable and overcurrent will be active LOW		Power enable and overcurrent will be active HIGH	
2	ACA_DOCK	Disabled		Enabled	
84	PWR_EN_SEL	Individual		Gang	
63	PIN_STRAP ^[13]	No pin-straping		Pin-straping configuration enabled	
4	PORT_DISABLE[1]	PORT_DISABLE[1:0] = b'00: DS1, DS2, DS3, DS4 active b'01: DS1, DS2, DS3 active b'10: DS1, DS2 active b'11: DS1 active Pin-straps cannot enable ports disabled by factory setting.			
3	PORT_DISABLE[0]				
6	NON_REMOVABLE[1] ^[14]	NON_REMOVABLE[1:0] = b'00: DS1, DS2, DS3, DS4 removable b'01: DS1, DS2, DS3 removable b'10: DS1, DS2 removable b'11: DS1 removable			
5	NON_REMOVABLE[0] ^[14]				
85	VID[2]	Reserved. If PIN_STRAP is enabled and CY VID is required, strap VID[2:0] to '1'.			
64	VID[1]				
43	VID[0]				
38	DS1_CDP_EN ^[15]	strapped '0'	strapped '1'	strapped '0'	strapped '1'
		DS1 CDP enabled	DS1 CDP disabled	DS1 CDP disabled	DS1 CDP enabled
86	DS2_CDP_EN ^[15]	DS2 CDP enabled	DS2 CDP disabled	DS2 CDP disabled	DS2 CDP enabled
87	DS3_CDP_EN ^[15]	DS3 CDP enabled	DS3 CDP disabled	DS3 CDP disabled	DS3 CDP enabled
35	DS4_CDP_EN ^[15]	DS4 CDP enabled	DS4 CDP disabled	DS4 CDP disabled	DS4 CDP enabled

Notes

11. See [Figure 16 on page 25](#) and [Figure 17 on page 25](#).
12. I2C_DEV_ID is valid only when HX3 is in I²C slave mode.
13. VID, PORT_DISABLE, NON_REMOVABLE are group straps. If one of the pins in a group strap is floating (INVALID), that group input will be INVALID and the default will not be overwritten.
14. These DS ports are exposed ports and the connected devices can be removed.
15. DS_x_CDP_EN will be active LOW input when PWR_SW_POL is set to active LOW; similarly DS_x_CDP_EN will be active HIGH input when PWR_SW_POL is set to active HIGH.

I²C Configuration

When enabled for I²C configuration through the MODE_SEL pins (See Table 5 on page 24), HX3 can be configured as an I²C master or as an I²C slave. HX3's configuration data is a maximum of 197 bytes and HX3's firmware is 10 KB. Note that HX3's firmware also includes configuration settings.

HX3 as I²C Master

HX3 reads configurations from an external I²C EEPROM with sizes ranging from 16 to 64 KB. An example of a supported EEPROM is 24LC128. Based on the contents of the bSignature and bImageType fields in Table 8 on page 27, HX3 performs one of the following actions:

- Loads custom configuration settings from the EEPROM when bSignature is "CY" and bImageType is 0xD4.
- Loads the Cypress-provided firmware from the EEPROM when bSignature is "CY" and bImageType is 0xB0. This firmware also includes configuration settings.
- If bSignature ≠ "CY", HX3 enumerates in the vendor-specific mode.

The contents of the EEPROM can be updated with the easy-to-use [Cypress Blaster Plus](#) tool. Blaster Plus is a GUI-based tool to configure HX3. This tool allows to do the following:

- Download the Cypress-provided firmware from a PC via HX3's US port and store it on an EEPROM connected to HX3's I²C port.

Table 8. EEPROM Map

I ² C Offset	Bits	Name	Default	Description
0	7:0	bSignature LSB ("C")	0x43	The first byte of the 2-byte signature initialized with "CY" ASCII text. When the signature is not valid, the hub enumerates as a vendor-specific device.
1	7:0	bSignature MSB ("Y")	0x59	The second byte of the 2-byte signature initialized with "CY" ASCII text. When the signature is not valid, the hub enumerates as a vendor-specific device.
2	7:6	bImageCTL	b'00	Reserved
	5:4	I ² C Speed	b'11	b'01: 400 kHz b'11: 100 kHz
	3:1	bImageCTL	b'000	Reserved
	0	bImageCTL	0	0: Execution binary file 1: Data file
3	7:0	bImageType	0xD4	0xD4: Load only configuration 0xB0: Load firmware boot image All other bImageType will return an error code.

- Read the configuration settings from the EEPROM. These settings are displayed in the Blaster Plus GUI. Modify settings as required.
- Write back the updated settings on to the EEPROM. In addition, an image file can be created for external use.

The EEPROM addresses for small and large EEPROM is shown in Table 7.

Small EEPROM refers to one-byte address I²C EEPROM with size ranging from 128-byte to 2K-byte while Large EEPROM refers to two-byte address I²C EEPROM with size ranging from 4K-byte to 256K-byte.

Table 7. EEPROM Addresses

EEPROM Type	EEPROM Address	Blaster Plus I ² C Address
Small EEPROM	0x50	0xA0
Large EEPROM	0x51	0xA2

The Blaster Plus tool, user guide, and the Cypress-provided firmware are available at www.cypress.com/hx3.

HX3 as I²C Slave

An external I²C master can program the configuration settings into HX3 according to the EEPROM map in Table 8. Alternatively, the HX3 firmware (<10 KB), which includes configuration settings, can also be programmed. It is recommended to use the Blaster Plus tool to create the HX3 firmware or configuration image file. HX3's I²C slave address needs to be provided while creating the image file. Refer to Table 6 on page 26 for HX3's I²C slave address.

Table 8. EEPROM Map (continued)

I ² C Offset	Bits	Name	Default	Description
4	7:0	bD4Length	40	bD4Length is defined in bytes as the length from offset 5. I ² C offset bytes 0–4 are the header bytes. bD4Length = 6: Only update VID, PID, and DID bD4Length = 18: Configuration options (no PHY trim) bD4Length = 40: Configuration options with PHY trim options bD4Length > 40: User must provide valid string descriptors bD4Length > 192: Error
5	7:0	VID [7:0]	0xB4	Custom Vendor ID - LSB
6	7:0	VID [15:8]	0x04	Custom Vendor ID - MSB
7	7:0	PID [7:0]	0x04	Custom Product ID (PID)
8	7:0	PID [15:8]	0x65	Default: 0x6504 If separate PID is used for USB 2.0, the USB 2.0 PID will be read from offset 35 and 36. Else, USB 2.0 PID = PID+2; Default: 0x6506 Refer to Table 9 on page 33 for other default PID values for different parts.
9	7:0	DID [7:0]	00 - 88-pin QFN, 10 - 68-pin QFN	Custom Device ID - revision - LSB
10	7:0	DID [15:8]	50	Custom Device ID - revision - MSB
11	7:0	Reserved	0	Reserved
12	7:4	SHARED_LINK_EN	b'0000	Enable Shared Link on DS port bit[7:4]=DS4, DS3, DS2, DS1 0: Shared Link not enabled 1: Shared Link enabled
	3:0	SHC_ACTIVE_PORTS [3:0]	b'1111	Indicates if a SuperSpeed port is active. bit[3:0] = DS4, DS3, DS2, DS1 0: Not active 1: Active
13	7:0	POWER_ON_TIME	0x32	Time (in 2-ms intervals) from the time the power-on sequence begins on a port until power is good on that port (bPwron2PwrGood)
14	7:4	REMOVABLE_PORTS [3:0]	b'1111	Indicates if the port is removable. bit[7:4]=DS4, DS3, DS2, DS1 0: Non-removable 1: Removable
	3:0	UHC_ACTIVE_PORTS [3:0]	b'1111	Indicates if a USB 2.0 port is active. bit[3:0]=DS4, DS3, DS2, DS1 0: Not active 1: Active

Table 8. EEPROM Map (continued)

I ² C Offset	Bits	Name	Default	Description
15	7	SS_LED_PIN_CONTROL	0	Port 1–4: SS LED disable 0: DS[1:4]_LED_SS are LEDs. The LED glows when the SS port is active and not in disabled state. 1: DS[1:4]_LED_SS are not LEDs
	6	GREEN_LED_PIN_CONTROL	0	Port 1–4: USB 2.0 Green LED disable 0: DS[1:4]_GREEN are LEDs 1: DS[1:4]_GREEN are not LEDs
	5	AMBER_LED_PIN_CONTROL	0	Port 1–4: USB 2.0 Amber LED disable 0: DS[1:4]_AMBER are LEDs 1: DS[1:4]_AMBER are not LEDs
	4	PORT_INDICATORS	1	Port indicators supported 0: Port indicators are not supported on its DS-facing ports and the USB 2.0 PORT_INDICATOR request has no effect. 1: Port indicators are supported on its DS-facing ports and the USB 2.0 PORT_INDICATOR request controls the indicators.
	3	COMPOUND_HUB	0	Identifies a compound device. 0: Hub is not part of a compound device. 1: Hub is part of a compound device.
	2:1	Reserved	0	Reserved
	0	GANG	0	1: Ganged power switch enable for all DS ports 0: Individual port power switch enable for each DS port
16	7	SUSPEND_INDICATOR_DISABLE	0	0: Suspend indicator enabled 1: Suspend indicator disabled
	6	SS_US_DISABLE	0	Hub mode of operation (USB 3.0 or USB 2.0) 0: USB 3.0 hub and USB 2.0 hub enabled 1: USB 3.0 hub disabled and USB 2.0 hub enabled
	5	PWR_EN_POLARITY	0	Power switch control output polarity 0: Active LOW 1: Active HIGH
	4:0	PORT_POLARITY	b'00000	USB 2.0 DP and DM swapped bit[4:0]=DS4, DS3, DS2, DS1, US 1: Port polarity swapped 0: Port polarity not swapped
17	7:5	Reserved	0	Reserved
	4	BC_ENABLE	1	0: BC v1.2 disabled 1: BC v1.2 enabled
	3	ACA_DOCK	0	If this bit is set, enable ACA-Dock on the US port
	2	APPLE_XA	0	0: Max limit for Apple charging 2.1 A 1: Max limit for Apple charging 1 A
	1	Reserved	0	Reserved
	0	GHOST_CHARGE_EN	1	0: Ghost Charging disabled 1: Ghost Charging enabled
18	7:4	CDP_EN[3:0]	b'1111	Per-port charging setting bit[7:4]=DS4, DS3, DS2, DS1 0: CDP disabled 1: CDP enabled
	3:0	DCP_EN[3:0]	b'0000	Per-port charging setting bit[3:0]=DS4, DS3, DS2, DS1 0: DCP disabled 1: DCP enabled

Table 8. EEPROM Map (continued)

I ² C Offset	Bits	Name	Default	Description
19	7	EMBEDDED_HUB	0	If this bit is set, the US is as an embedded port and VBUS connected to VBUS_US pin is ignored.
	6	ILLEGAL_DESCRIPTOR	1	If this bit is set, the USB 2.0 hub controller will accept both 0x00 and 0x29 as valid descriptor types. If '0', only 0x29 will be accepted as a valid descriptor type.
	5	Reserved	1	Reserved
	4	OC_POLARITY	0	Overcurrent input polarity 0: Active LOW 1: Active HIGH
	3:0	OC_TIMER	b'1000	Time in milliseconds for which the overcurrent inputs will be filtered
20	7:0	Reserved	0	Reserved
21	7:4	Reserved	0	Reserved
	3	STRING_DESCRIPTOR_ENABLE ^[16]	0	0: String descriptor support is disabled 1: String descriptor support is enabled When string descriptors are not supported, the hub controller returns a non-zero index (compile-time programmable) for each string which is supported, and 0x00 for each string not supported, as indicated by this field.
	2:0	Reserved	0	Reserved
22	7:0	Reserved	0	Reserved
23	7:6	HS_AMPLITUDE_DS4	b'00	HS driver amplitude control; HS driver current: +0% to +7.5% b'00: Default b'01: +2.5% b'10: +5% b'11: +7.5%
	5:4	HS_AMPLITUDE_DS3	b'00	
	3:2	HS_AMPLITUDE_DS2	b'00	
	1:0	HS_AMPLITUDE_DS2	b'00	
24	7:6	HS_AMPLITUDE_US	b'00	HS driver slope control for all ports b'0000: +15% b'0001: +5% b'0100: Default b'0101: -5% b'1111: -7.5%
	5:2	HS_SLOPE	b'0100	
	1:0	HS_TX_VREF	b'10	

Note

16. When the string descriptor supports LangID, Manufacturer, Product and Serial Number, the serial number must be unique for each device.

Table 8. EEPROM Map (continued)

I ² C Offset	Bits	Name	Default	Description
25	7:3	HS_PREEMP_EN[4:0]	b'00000	HS driver pre-emphasis enable – for ports DS4, DS3, DS2, DS1, and US 0: pre-emphasis is disabled 1: pre-emphasis is enabled
	2	HS_PREEMP_DEPTH_DS4 ^[17]	0	HS driver pre-emphasis depth 0: +10% 1: +20%
	1	HS_PREEMP_DEPTH_DS3 ^[17]	0	
	0	HS_PREEMP_DEPTH_DS2 ^[17]	0	
26	7	HS_PREEMP_DEPTH_DS1 ^[17]	0	
	6	HS_PREEMP_DEPTH_US ^[17]	0	
	5	Reserved	1	Reserved
	4:1	PCS_TX_DEEMPH_DS4	0x6	USB 3.0 Tx driver de-emphasis value 0x3: -2.75 dB 0x6: -3.4 dB (Default) 0x9: -4.0 dB
27	7:4	PCS_TX_DEEMPH_DS3	0x6	USB 3.0 Tx driver de-emphasis value 0x3: -2.75 dB 0x6: -3.4 dB (Default) 0x9: -4.0 dB
	3:0	PCS_TX_DEEMPH_DS2	0x6	
28	7:4	PCS_TX_DEEMPH_DS1	0x6	USB 3.0 Tx driver de-emphasis value 0x3: -2.75 dB 0x6: -3.4 dB (Default) 0x9: -4.0 dB
	3:0	PCS_TX_DEEMPH_US	0x6	
29	7	Reserved	0	Reserved
	6	Reserved	1	Reserved
	5:0	PCS_TX_SWING_FULL_DS4	0x29	Adjust launch amplitude of the transmitter 0x1F – 0.9 V 0x29 – 1.0 V (Default) 0x35 – 1.1 V 0x3F – 1.2 V
30	7:6	Reserved	0	Reserved
	5:0	PCS_TX_SWING_FULL_DS3	0x29	Adjust launch amplitude of the transmitter 0x1F – 0.9 V 0x29 – 1.0 V (Default) 0x35 – 1.1 V 0x3F – 1.2 V
31	7:6	Reserved	0	Reserved
	5:0	PCS_TX_SWING_FULL_DS2	0x29	Adjust launch amplitude of the transmitter 0x1F – 0.9 V 0x29 – 1.0 V (Default) 0x35 – 1.1 V 0x3F – 1.2 V
32	7:6	Reserved	0	Reserved
	5:0	PCS_TX_SWING_FULL_DS1	0x29	Adjust launch amplitude of the transmitter 0x1F – 0.9 V 0x29 – 1.0 V (Default) 0x35 – 1.1 V 0x3F – 1.2 V

Note

17. HS_PREEMP_DEPTH is valid only when corresponding HS_PREEMP_EN is set for that port.

Table 8. EEPROM Map (continued)

I ² C Offset	Bits	Name	Default	Description
33	7:6	Reserved	0	Reserved
	5:0	PCS_TX_SWING_FULL_US	0x29	Adjust launch amplitude of the transmitter 0x1F – 0.9 V 0x29 – 1.0 V (Default) 0x35 – 1.1 V 0x3F – 1.2 V
34	7:0	Reserved	0	Reserved
35	7:0	UHC_PID [7:0]_LSB	0x06	USB 2.0 PID. If bD4Length ≥ 40, USB 2.0 PID will be read from this location.
36	7:0	UHC_PID [15:8]_MSB	0x65	
37–44	7:0	Reserved	0	Eight bytes reserved for future expansion
45	7:0	bLength: LangID	4	Size of LangID (defined by spec as N+2)
46	7:0	DescType	3	String descriptor type (constant value)
47	7:0	LangID - MSB	9	String language ID - MSB of wLangID
48	7:0	LangID - LSB	4	String language ID - MSB of wLangID
49	7:0	bLength: Manufacturer (X)	54	Manufacturer string length (“bLength: LangID + bLength: Manufacturer + bLength: Product + bLength: Serial Number” should be less than or equal to 152 bytes). X ≤ 66.
50	7:0	DescType	3	String descriptor type (constant value)
51	7:0	bString: Manufacturer	'2', 0, '0', 0, '1', 0, '4', 0, ' ', 0, 'C', 0, 'y', 0, 'p', 0, 'r', 0, 'e', 0, 's', 0, 's', 0, ' ', 0, 'S', 0, 'e', 0, 'm', 0, 'i', 0, 'c', 0, 'o', 0, 'n', 0, 'd', 0, 'u', 0, 'c', 0, 't', 0, 'o', 0, 'r', 0	Manufacturer string: UNICODE UTF-16LE per USB 2.0 specification: “2014 Cypress Semiconductor”
49 + X	7:0	bLength: Product (Y)	22	Product string length (“bLength: LangID + bLength: Manufacturer + bLength: Product + bLength: Serial Number” should be less than or equal to 152 bytes). Y ≤ 66.
50 + X	7:0	DescType	3	String descriptor type (constant value)
51 + X	7:0	bString: Product	'C', 0, 'Y', 0, '-', 0, 'H', 0, 'X', 0, '3', 0, ' ', 0, 'H', 0, 'U', 0, 'B', 0	Product string: UNICODE UTF-16LE per USB 2.0 specification: “CY-HX3 HUB”
49 + X + Y	7:0	bLength: Serial Number (Z)	22	Serial number string length (“bLength: LangID + bLength: Manufacturer + bLength: Product + bLength: Serial Number” should be less than or equal to 152 bytes). Z ≤ 66.
50 + X + Y	7:0	DescType	3	String descriptor type (constant value)
51 + X + Y	7:0	bString: Serial Number	'1', 0, '2', 0, '3', 0, '4', 0, '5', 0, '6', 0, '7', 0, '8', 0, '9', 0, 'A', 0	Serial number string: UNICODE UTF-16LE per USB 2.0 specification: “123456789A”

Table 9 contains example values of PID for different parts.

Table 9. PID Values

Part Number	VID	PID (USB 3.0)	PID (USB 2.0)	Vendor Mode PID (USB 2.0)
CYUSB3304-68LTXC, CYUSB3302-68LTXC	0x04B4	0x6500	0x6502	0x6503
CYUSB3314-88LTXC, CYUSB3312-88LTXC	0x04B4	0x6504	0x6506	0x6503
CYUSB3328-88LTXC, CYUSB3326-88LTXC	0x04B4	0x6508	0x650A	0x6507

Note: In I²C Master boot mode, if the connected EEPROM contains invalid signature or is blank, the hub will come up in Vendor mode in 2.0 configuration with a default Vendor Mode PID as mentioned in [Table 9](#).

EMI

HX3 meets the EMI requirements outlined by FCC 15B (USA) and EN55022 (Europe) for consumer electronics. HX3 tolerates EMI conducted by aggressors outlined by the above specifications and continues to function as expected.

ESD

HX3 has a built-in ESD protection on all pins. The ESD protection level provided on these ports is 2.2 kV Human Body Model (HBM) based on the JESD22-A114 specification.

Absolute Maximum Ratings

Exceeding maximum ratings may shorten the useful life of the device. User guidelines are not tested.

Storage temperature..... -65 °C to +150 °C
 Operating temperature -40 °C to +85 °C

Electrostatic discharge voltage 2200 V
 Oscillator or crystal frequency 26 MHz ±150 ppm
 I/O voltage supply 3 V to 3.6 V
 Maximum input sink current per I/O 4 mA

Electrical Specifications

HX3 meets all USB-IF Electrical Compliance specifications.

DC Electrical Characteristics

Table 10. DC Electrical Characteristics

Parameter	Description	Conditions	Min	Typ	Max	Units
DVDD12	1.2 V core supply	–	1.14	1.2	1.26	V
VDD_EFUSE	eFuse supply	Normal operation	1.14	1.2	1.26	V
		Programming	2.5	2.6	2.7	V
AVDD12	1.2 V analog supply	–	1.14	1.2	1.26	V
VDD_IO	3.3 V I/O supply	–	3	3.3	3.6	V
AVDD33	3.3 V analog supply	–	3	3.3	3.6	V
V _{IH}	Input HIGH voltage	–	0.7 × VDD_IO	–	VDD_IO	V
V _{IL}	Input LOW voltage	–	0	–	0.3 × VDD_IO	V
V _{OH}	Output HIGH voltage	Output HIGH voltage at I _{OH} ≤ +4 mA	2.4	–	–	V
V _{OL}	Output LOW voltage	Output LOW voltage at I _{OL} ≥ -4 mA	–	–	0.4	V
I _{OS}	Input sink current	LED GPIO usage	–	–	4	mA
I _{IX}	Input leakage current	All I/O signals held at VDD_IO or GND	-1	–	1	µA
I _{OZ}	Output HI-Z leakage current	–	–	–	10	µA
I _{CC}	1.2 V supplies combined operating current	–	–	410	526	mA
I _{CC}	3.3 V supplies combined operating current	–	–	260	286	mA
V _{RAMP}	Voltage ramp rate on core and I/O supplies	Voltage ramp must be monotonic	0.2	–	50	V/ms
V _N	Noise level permitted on core and I/O supplies	Max p-p noise level permitted on all supplies except AVDD	–	–	100	mV
V _{N_USB}	Noise level permitted on AVDD12 and AVDD33 supply	Max p-p noise level permitted USB supply	–	–	20	mV

Power Consumption

Table 11 provides the power consumption estimates for HX3 under different conditions. Table 12 summarizes the power consumption for various combinations of devices connected to DS ports.

For example, to calculate the HX3 power consumption for three SS devices connected to DS ports (and no device connected to one DS port), and a US port connected to a USB 3.0 host:

$$\text{Power consumption} = [a] + 2*[g] = 492.5 + 2*76 = 644 \text{ mW}$$

[a] is the active power consumption for the US port connected to a USB 3.0 host and the SS device connected to the DS port.

[g] is the incremental power consumption for an additional SS device connected to the DS port.

Table 11. Power Consumption Estimates for Various Usage Scenarios

Device Condition	Number and Speed of DS Ports Connected	Typical Consumption			Comments
		Supply Current (mA)		Power (mW)	
		1.2 V	3.3 V		
Suspend ^[18]	NA	12.0	7.1	37.8	–
Active power with USB 3.0 host ^[19]	1 SS	204.1	75.0	492.5	[a]
	1 HS	51.2	45.2	210.7	[b]
	1 FS	51.2	34.0	173.7	[c]
	1 SS + 1 HS	218.0	103.4	602.9	[d]
Active power with USB 2.0 host ^[19, 20]	1 HS	51.2	45.2	210.7	[e]
	1 FS	51.2	34.0	173.7	[f]
Incremental active power for additional DS port	SS	39.4	8.7	76.0	[g]
	HS	7.0	19.8	73.7	[h]
	FS	7.0	14.2	55.2	[i]
Active power saving per disabled DS port ^[21]	–	10.6	9.6	44.4	[j]

Table 12. Power Consumption Under Various Configurations

Configuration	Number of DS Devices Connected With Data Transfer	Typical Consumption			Comments
		Supply Current (mA)		Power (mW)	
		1.2 V	3.3 V		
USB 3.0 4-Port Hub (USB 3.0 host)	4 SS devices	322	101	720	[a] + 3*[g]
	3 SS + 1 HS devices	297	121	755	[d] + 2*[g]
	3 SS devices	283	92	644	[a] + 2*[g]
USB 3.0 4-Port Hub with one port disabled (USB 3.0 host)	3 SS devices	272	83	600	[a] + 2*[g] - [j]
	2 SS + 1 HS devices	247	103	634	[d] + [g] - [j]
Shared Link with eight DS ports	4 SS + 4 HS devices	357	189	1052	[d] + 3*([g] + [h])
USB 2.0 4-Port Hub (USB 2.0 host)	4 HS devices	72	105	432	[e] + 3*[h]
	3 HS + 1 FS devices	72	99	413	[e] + 2*[h] + [i]

Notes

18. US port in low-power state (SS in U3 and USB 2.0 in L2).

19. All four DS ports are enabled.

20. US SS disabled using configuration options. Refer to Table 8 on page 27 for I²C configuration options.

21. Power saving applicable only with a USB 3.0 host. DS ports can be disabled through configuration options. Refer to Table 6 on page 26 for pin-strapping and Table 8 on page 27 for I²C configuration options.

Ordering Information

Table 13 lists HX3's ordering information. The table contains only the part numbers that are currently available for order. Additional part numbers for industrial temperature range can be made available on request. For more information, visit the Cypress [website](#) or contact the local sales representative.

Table 13. Ordering Information

Serial No.	Ordering Part Number	Number of DS Ports	Number of Shared Link Ports	Ghost Charge	ACA-Dock	Temperature	Package
1.	CYUSB3302-68LTXC	2 (USB 3.0)	0	Yes	No	0 °C–70 °C	68-pin QFN
2.	CYUSB3302-68LTXI	2 (USB 3.0)	0	Yes	No	–40 °C–85 °C	68-pin QFN
3.	CYUSB3304-68LTXC	4 (USB 3.0)	0	Yes	No	0 °C–70 °C	68-pin QFN
4.	CYUSB3304-68LTXI	4 (USB 3.0)	0	Yes	No	–40 °C–85 °C	68-pin QFN
5.	CYUSB3312-88LTXC	2 (USB 3.0)	0	Yes	No	0 °C–70 °C	88-pin QFN
6.	CYUSB3312-88LTXCT	2 (USB 3.0)	0	Yes	No	0 °C–70 °C	88-pin QFN
7.	CYUSB3312-88LTXI	2 (USB 3.0)	0	Yes	No	–40 °C–85 °C	88-pin QFN
8.	CYUSB3312-88LTXIT	2 (USB 3.0)	0	Yes	No	–40 °C–85 °C	88-pin QFN
9.	CYUSB3314-88LTXC	4 (USB 3.0)	0	Yes	No	0 °C–70 °C	88-pin QFN
10.	CYUSB3314-88LTXCT	4 (USB 3.0)	0	Yes	No	0 °C–70 °C	88-pin QFN
11.	CYUSB3314-88LTXI	4 (USB 3.0)	0	Yes	No	–40 °C–85 °C	88-pin QFN
12.	CYUSB3314-88LTXIT	4 (USB 3.0)	0	Yes	No	–40 °C–85 °C	88-pin QFN
13.	CYUSB3324-88LTXC	4 (USB 3.0)	0	Yes	Yes	0 °C–70 °C	88-pin QFN
14.	CYUSB3324-88LTXCT	4 (USB 3.0)	0	Yes	Yes	0 °C–70 °C	88-pin QFN
15.	CYUSB3324-88LTXI	4 (USB 3.0)	0	Yes	Yes	–40 °C–85 °C	88-pin QFN
16.	CYUSB3324-88LTXIT	4 (USB 3.0)	0	Yes	Yes	–40 °C–85 °C	88-pin QFN
17.	CYUSB3326-88LTXC	6 (2 USB 3.0, 2 SS, 2 USB 2.0)	2	Yes	No	0 °C–70 °C	88-pin QFN
18.	CYUSB3326-88LTXCT	6 (2 USB 3.0, 2 SS, 2 USB 2.0)	2	Yes	No	0 °C–70 °C	88-pin QFN
19.	CYUSB3326-88LTXI	6 (2 USB 3.0, 2 SS, 2 USB 2.0)	2	Yes	No	–40 °C–85 °C	88-pin QFN
20.	CYUSB3326-88LTXIT	6 (2 USB 3.0, 2 SS, 2 USB 2.0)	2	Yes	No	–40 °C–85 °C	88-pin QFN
21.	CYUSB3328-88LTXC	8 (4 SS, 4 USB 2.0)	4	Yes	Yes	0 °C–70 °C	88-pin QFN
22.	CYUSB3328-88LTXCT	8 (4 SS, 4 USB 2.0)	4	Yes	Yes	0 °C–70 °C	88-pin QFN
23.	CYUSB3328-88LTXI	8 (4 SS, 4 USB 2.0)	4	Yes	Yes	–40 °C–85 °C	88-pin QFN
24.	CYUSB3328-88LTXIT	8 (4 SS, 4 USB 2.0)	4	Yes	Yes	–40 °C–85 °C	88-pin QFN
25.	CYUSB3302-BVXC	2 (USB 3.0)	0	Yes	No	0 °C–70 °C	100-ball BGA
26.	CYUSB3302-BVXI	2 (USB 3.0)	0	Yes	No	–40–85 °C	100-ball BGA
27.	CYUSB3304-BVXC	4 (USB 3.0)	0	Yes	No	0 °C–70 °C	100-ball BGA
28.	CYUSB3304-BVXI	4 (USB 3.0)	0	Yes	No	–40 °C–85 °C	100-ball BGA
29.	CYUSB3312-BVXC	2 (USB 3.0)	0	Yes	No	0 °C–70 °C	100-ball BGA
30.	CYUSB3312-BVXI	2 (USB 3.0)	0	Yes	No	–40 °C–85 °C	100-ball BGA
31.	CYUSB3314-BVXC	4 (USB 3.0)	0	Yes	No	0 °C–70 °C	100-ball BGA
32.	CYUSB3314-BVXI	4 (USB 3.0)	0	Yes	No	–40 °C–85 °C	100-ball BGA
33.	CYUSB3324-BVXC	4 (USB 3.0)	0	Yes	Yes	0 °C–70 °C	100-ball BGA
34.	CYUSB3324-BVXI	4 (USB 3.0)	0	Yes	Yes	–40 °C–85 °C	100-ball BGA

Table 13. Ordering Information (continued)

Serial No.	Ordering Part Number	Number of DS Ports	Number of Shared Link Ports	Ghost Charge	ACA-Dock	Temperature	Package
35.	CYUSB3326-BVXC	6 (2 USB 3.0, 2 SS, 2 USB 2.0)	2	Yes	No	0 °C–70 °C	100-ball BGA
36.	CYUSB3326-BVXI	6 (2 USB 3.0, 2 SS, 2 USB 2.0)	2	Yes	No	–40 °C–85 °C	100-ball BGA
37.	CYUSB3328-BVXC	8 (4 SS, 4 USB 2.0)	4	Yes	Yes	0 °C–70 °C	100-ball BGA
38.	CYUSB2302-68LTXI	2 (USB 2.0)	0	Yes	No	–40 °C–85 °C	68-pin QFN
39.	CYUSB2304-68LTXI	4 (USB 2.0)	0	Yes	No	–40 °C–85 °C	68-pin QFN

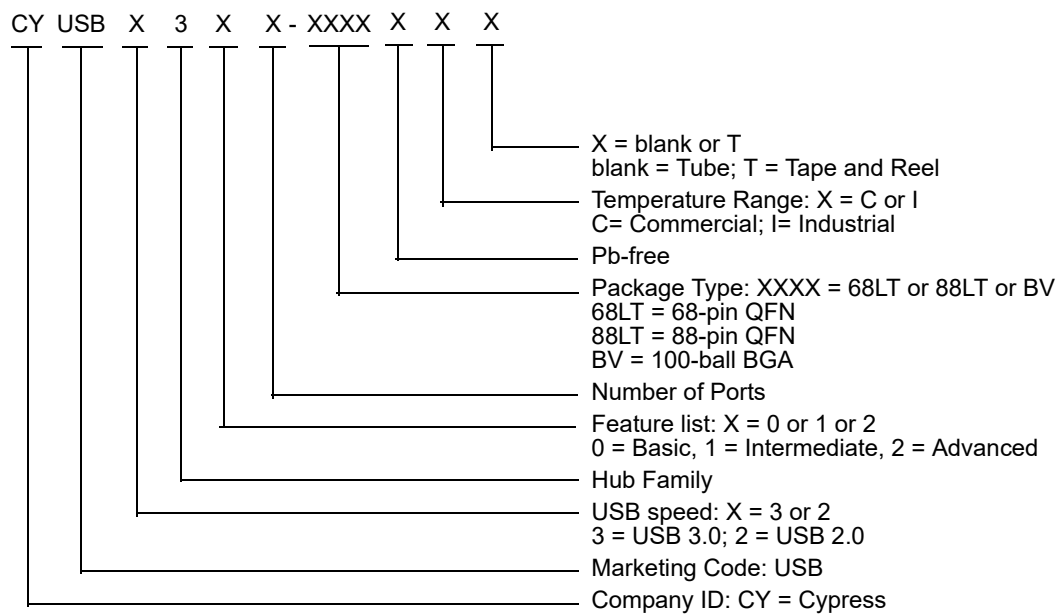
Ordering Code Definitions

Packaging

Table 14. Package Characteristics

Parameter	Description	Min	Typ	Max	Units
T _A	Operating ambient temperature	-40	-	85	°C
T _J	Operating junction temperature	-40	-	125	°C
T _{JA}	Package J _A (68-pin QFN)	-	16.2	-	°C/W
T _{JA}	Package J _A (88-pin QFN)	-	15.7	-	°C/W
T _{JA}	Package J _A (100-ball BGA)	-	35	-	°C/W
T _{JC}	Package J _C (68-pin QFN)	-	23.8	-	°C/W
T _{JC}	Package J _C (88-pin QFN)	-	18.9	-	°C/W
T _{JC}	Package J _C (100-ball BGA)	-	12	-	°C/W

Table 15. Solder Reflow Peak Temperature

Package	Maximum Peak Temperature	Maximum Time at Peak Temperature
68-pin QFN	260 °C	30 seconds
88-pin QFN	260 °C	30 seconds
100-ball BGA	260 °C	30 seconds

Table 16. Package Moisture Sensitivity Level (MSL), IPC/JEDEC J-STD-2

Package	MSL
68-pin QFN	MSL 3
88-pin QFN	MSL 3
100-ball BGA	MSL 3

Package Diagrams

Figure 18. 68-pin QFN (8 × 8 × 1.0 mm) LT68B 5.1 × 5.1 mm EPAD (Sawn) Package Outline

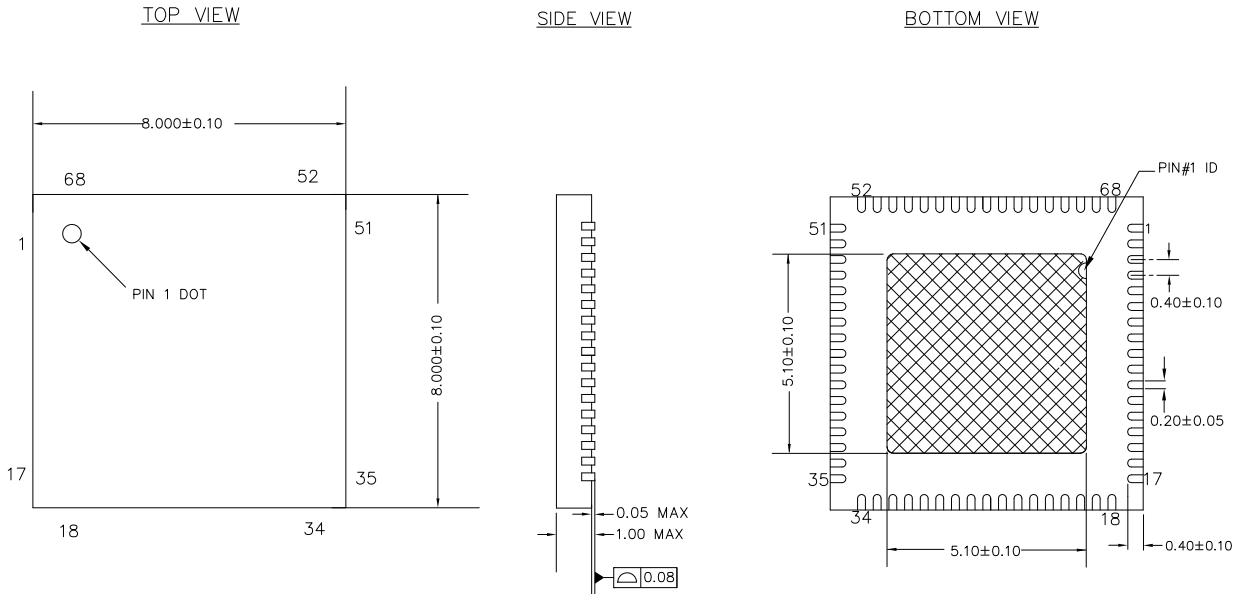

NOTES:

1. HATCH AREA IS SOLDERABLE EXPOSED PAD
2. REFERENCE JEDEC#: MO-220
3. ALL DIMENSIONS ARE IN MILLIMETERS

001-78925 *B

Figure 19. 88-pin QFN (10 × 10 × 1.0 mm) LT88B 5.3 × 5.3 EPAD (Sawn) Package Outline

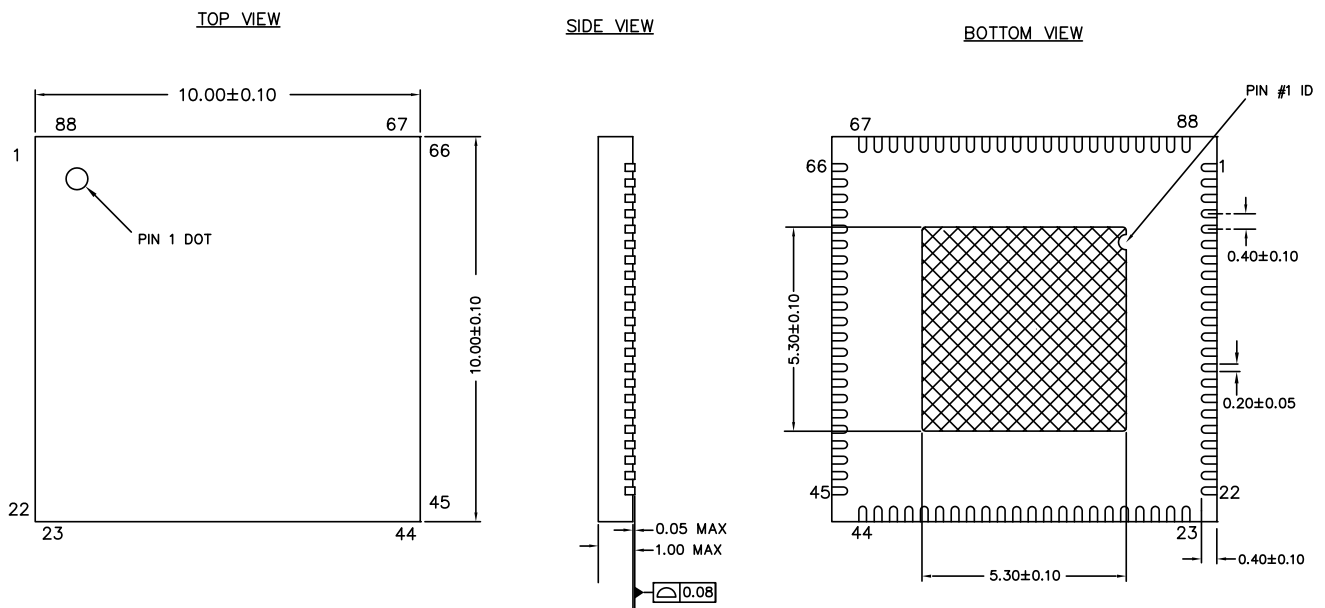

001-76569 *B

Figure 20. 100-Ball BGA (6.0 × 6.0 × 1.0 mm) BZ100 Package Outline

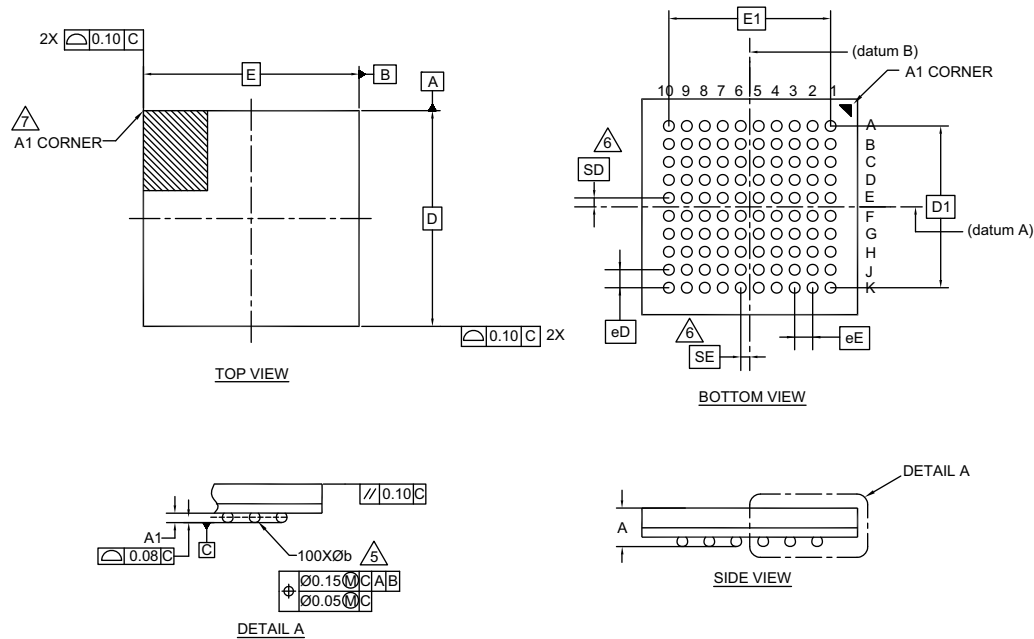

SYMBOL	DIMENSIONS		
	MIN.	NOM.	MAX.
A	-	-	1.00
A1	0.16	-	-
D	6.00 BSC		
E	6.00 BSC		
D1	4.50 BSC		
E1	4.50 BSC		
MD	10		
ME	10		
N	100		
Ø b	0.25	0.30	0.35
eD	0.50 BSC		
eE	0.50 BSC		
SD	0.25 BSC		
SE	0.25 BSC		

NOTES:

- ALL DIMENSIONS ARE IN MILLIMETERS.
- SOLDER BALL POSITION DESIGNATION PER JEP95, SECTION 3, SPP-020.
- "e" REPRESENTS THE SOLDER BALL GRID PITCH.
- SYMBOL "MD" IS THE BALL MATRIX SIZE IN THE "D" DIRECTION. SYMBOL "ME" IS THE BALL MATRIX SIZE IN THE "E" DIRECTION. N IS THE NUMBER OF POPULATED SOLDER BALL POSITIONS FOR MATRIX SIZE MD X ME.
- DIMENSION "b" IS MEASURED AT THE MAXIMUM BALL DIAMETER IN A PLANE PARALLEL TO DATUM C.
- "SD" AND "SE" ARE MEASURED WITH RESPECT TO DATUMS A AND B AND DEFINE THE POSITION OF THE CENTER SOLDER BALL IN THE OUTER ROW. WHEN THERE IS AN ODD NUMBER OF SOLDER BALLS IN THE OUTER ROW "SD" OR "SE" = 0. WHEN THERE IS AN EVEN NUMBER OF SOLDER BALLS IN THE OUTER ROW, "SD" = eD/2 AND "SE" = eE/2.
- A1 CORNER TO BE IDENTIFIED BY CHAMFER, LASER OR INK MARK METALIZED MARK, INDENTATION OR OTHER MEANS.
- "+" INDICATES THE THEORETICAL CENTER OF DEPOPULATED SOLDER BALLS.
- JEDEC SPECIFICATION NO. REF. : MO-195C.

51-85209 *F

Acronyms

Table 17. Acronyms Used in this Document

Acronym	Description
ACA	Accessory Charging Adapter
ASSP	Application-Specific Standard Product
BC	Battery Charging
CDP	Charging Downstream Port
DS	DownStream
DCP	Dedicated Charging Port
DNU	Do Not Use
DWG	Device Working Group
EEPROM	Electrically Erasable Programmable Read-Only Memory
FS	Full-Speed
FW	FirmWare
GND	GrouND
GPIO	General-Purpose Input/Output
HS	Hi-Speed
ISP	In-System Programming
I/O	Input/Output
LS	Low-Speed
NC	No Connect
OTG	On-The-Go
PID	Product ID
POR	Power-On Reset
ROM	Read-Only Memory
SCL	Serial CLock
SDA	Serial DATa
SS	SuperSpeed
TT	Transaction Translator
US	UpStream
VID	Vendor ID

Reference Documents

[USB 2.0 Specification](#)

[USB 3.0 Specification](#)

[Battery Charging Specification](#)

Document Conventions

Units of Measure

Table 18. Units of Measure

Symbol	Unit of Measure
°C	degree celsius
Ω	ohm
Gbps	gigabit per second
KB	kilobyte
kHz	kilohertz
kΩ	kiloohm
Mbps	megabit per second
MHz	megahertz
μA	microampere
mA	milliampere
ms	millisecond
mW	milliwatt
ns	nanosecond
ppm	parts per million
V	volt

Silicon Revision History

This datasheet is applicable for the USB-IF certified (TID# 330000060) HX3 Rev. *D and Rev. *C Silicon.

Rev. *D: This Silicon revision improves the yield of HX3, and is drop-in compatible for all the part numbers. There is no need to change the board design or layout to use the HX3 Rev. *D Silicon. Products are completely compatible with the HX3 Rev. *C Silicon.

Rev. *C: This Silicon revision fixes the errata applicable to the Rev. *A Silicon.

The following table defines the changes between Rev. *A, Rev. *C, and Rev. *D Silicon.

No.	Items	Part Numbers	Rev. *A	Rev. *C	Rev. *D
1	USB-IF Compliance	All	Requires firmware on external EEPROM	No external EEPROM required	No external EEPROM required
2	FS-only hub or host connected to HX3 Upstream Port	All	Not supported	Supported	Supported
3	Suspend Power	All	90 mW	37.8 mW	37.8 mW

Method of Identification

Markings on row 3 of the HX3 package differentiate Rev. *D Silicon from Rev. *C Silicon and Rev. *A Silicon as indicated in the example below. Cypress maintains traceability of product to wafer level, including wafer fabrication location, through the lot number marked on the package.

HX3 REV *A SILICON



HX3 REV *C SILICON

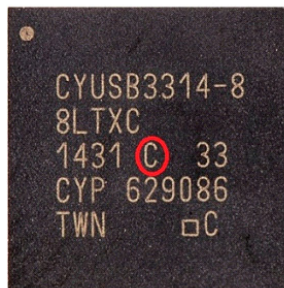

HX3 REV *D SILICON

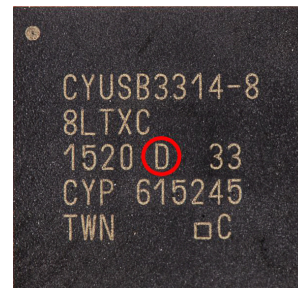

Document History Page

Document Title: CYUSB330x/CYUSB331x/CYUSB332x/CYUSB230x, HX3 USB 3.0 Hub				
Document Number: 001-73643				
Revision	ECN	Orig. of Change	Submission Date	Description of Change
*E	4271496	MURT	02/21/2014	Changed status from Preliminary to Final.
*F	4291210	MURT	02/25/2014	Post to external web.
*G	4308926	MURT	03/14/2014	Updated System Interfaces : Updated Configuration Options : Updated HX3 as I2C Slave : Updated Table 8 .
*H	4463533	MURT	08/01/2014	Updated Features : Replaced "USB 3.0-Certified Hub, TID# 330000047" with "USB 3.0-Certified Hub, TID# 330000060". Updated Electrical Specifications : Updated Power Consumption : Updated Table 11 : Removed "Host not attached", "Suspend with host attached" Device Conditions and their corresponding details. Added "Suspend" Device Condition and its corresponding details. Removed Errata.
*I	4483117	RAJM	08/22/2014	Added Silicon Revision History .
*J	4499514	RAJM	09/15/2014	Added 100-ball BGA Package related information in all instances across the document. Updated Ordering Information : Updated Table 13 : Updated part numbers. Updated Package Diagrams : Added spec 51-85209 *D.
*K	4582512	PRJI	11/28/2014	Updated HX3 Product Options : Updated Table 1 . Updated Pin Information : Updated Table 4 .
*L	4632890	HBM	01/20/2015	Updated Pin Information : Updated Figure 12 . Updated Figure 13 . Updated Table 4 . Added Packaging . Updated Package Diagrams : spec 51-85209 – Changed revision from *D to *E.
*M	4669639	HBM	02/24/2015	No technical updates.
*N	4764583	HBM	05/13/2015	Updated Package Diagrams : spec 001-76569 – Changed revision from *A to *B. Updated Silicon Revision History : Updated description and table below. Updated Method of Identification : Updated description and figure below.

Document History Page *(continued)*

Document Title: CYUSB330x/CYUSB331x/CYUSB332x/CYUSB230x, HX3 USB 3.0 Hub				
Document Number: 001-73643				
Revision	ECN	Orig. of Change	Submission Date	Description of Change
*O	4941772	HBM	11/25/2015	Updated HX3 Product Options : Updated Table 1 : Added CYUSB2302-68LTXI and CYUSB2304-68LTXI part numbers related information. Updated Ordering Information : Updated Table 13 : Updated part numbers. Completing Sunset Review.
*P	5466603	HBM	10/20/2016	Updated Features : Replaced "USB 3.0-Certified Hub, TID# 330000060" with "USB-IF Certified Hub, TID# 330000060, 30000074". Updated Package Diagrams : spec 51-85209 – Changed revision from *E to *F. Updated to new template. Completing Sunset Review.
*Q	5725383	GNKK	05/03/2017	Updated Cypress Logo and Copyright.
*R	6045135	HBM	01/25/2018	Updated HX3 Product Options : Updated Table 1 : Replaced "CYUSB2302-68LTXI" with "CYUSB2302" in column heading. Replaced "CYUSB2304-68LTXI" with "CYUSB2304" in column heading. Updated Ordering Information : Updated Table 13 : Updated part numbers. Updated Ordering Code Definitions . Updated to new template.
*S	6288337	MKRS	03/13/2019	Updated Pin Information : Updated Table 2 . Updated Table 3 . Updated Table 4 . Updated System Interfaces : Updated Configuration Options : Updated HX3 as I2C Master : Updated description. Added Table 7 . Updated HX3 as I2C Slave : Updated description. Updated Table 8 . Added Table 9 .
*T	6562235	HBM	04/30/2019	Updated to new template.

Sales, Solutions, and Legal Information

Worldwide Sales and Design Support

Cypress maintains a worldwide network of offices, solution centers, manufacturer's representatives, and distributors. To find the office closest to you, visit us at [Cypress Locations](#).

Products

Arm® Cortex® Microcontrollers	cypress.com/arm
Automotive	cypress.com/automotive
Clocks & Buffers	cypress.com/clocks
Interface	cypress.com/interface
Internet of Things	cypress.com/iot
Memory	cypress.com/memory
Microcontrollers	cypress.com/mcu
PSoC	cypress.com/psoc
Power Management ICs	cypress.com/pmic
Touch Sensing	cypress.com/touch
USB Controllers	cypress.com/usb
Wireless Connectivity	cypress.com/wireless

PSoC® Solutions

[PSoC 1](#) | [PSoC 3](#) | [PSoC 4](#) | [PSoC 5LP](#) | [PSoC 6 MCU](#)

Cypress Developer Community

[Community](#) | [Projects](#) | [Video](#) | [Blogs](#) | [Training](#) | [Components](#)

Technical Support

cypress.com/support



© Cypress Semiconductor Corporation, 2011–2019. This document is the property of Cypress Semiconductor Corporation and its subsidiaries ("Cypress"). This document, including any software or firmware included or referenced in this document ("Software"), is owned by Cypress under the intellectual property laws and treaties of the United States and other countries worldwide. Cypress reserves all rights under such laws and treaties and does not, except as specifically stated in this paragraph, grant any license under its patents, copyrights, trademarks, or other intellectual property rights. If the Software is not accompanied by a license agreement and you do not otherwise have a written agreement with Cypress governing the use of the Software, then Cypress hereby grants you a personal, non-exclusive, nontransferable license (without the right to sublicense) (1) under its copyright rights in the Software (a) for Software provided in source code form, to modify and reproduce the Software solely for use with Cypress hardware products, only internally within your organization, and (b) to distribute the Software in binary code form externally to end users (either directly or indirectly through resellers and distributors), solely for use on Cypress hardware product units, and (2) under those claims of Cypress's patents that are infringed by the Software (as provided by Cypress, unmodified) to make, use, distribute, and import the Software solely for use with Cypress hardware products. Any other use, reproduction, modification, translation, or compilation of the Software is prohibited.

TO THE EXTENT PERMITTED BY APPLICABLE LAW, CYPRESS MAKES NO WARRANTY OF ANY KIND, EXPRESS OR IMPLIED, WITH REGARD TO THIS DOCUMENT OR ANY SOFTWARE OR ACCOMPANYING HARDWARE, INCLUDING, BUT NOT LIMITED TO, THE IMPLIED WARRANTIES OF MERCHANTABILITY AND FITNESS FOR A PARTICULAR PURPOSE. No computing device can be absolutely secure. Therefore, despite security measures implemented in Cypress hardware or software products, Cypress shall have no liability arising out of any security breach, such as unauthorized access to or use of a Cypress product. CYPRESS DOES NOT REPRESENT, WARRANT, OR GUARANTEE THAT CYPRESS PRODUCTS, OR SYSTEMS CREATED USING CYPRESS PRODUCTS, WILL BE FREE FROM CORRUPTION, ATTACK, VIRUSES, INTERFERENCE, HACKING, DATA LOSS OR THEFT, OR OTHER SECURITY INTRUSION (collectively, "Security Breach"). Cypress disclaims any liability relating to any Security Breach, and you shall and hereby do release Cypress from any claim, damage, or other liability arising from any Security Breach. In addition, the products described in these materials may contain design defects or errors known as errata which may cause the product to deviate from published specifications. To the extent permitted by applicable law, Cypress reserves the right to make changes to this document without further notice. Cypress does not assume any liability arising out of the application or use of any product or circuit described in this document. Any information provided in this document, including any sample design information or programming code, is provided only for reference purposes. It is the responsibility of the user of this document to properly design, program, and test the functionality and safety of any application made of this information and any resulting product. "High-Risk Device" means any device or system whose failure could cause personal injury, death, or property damage. Examples of High-Risk Devices are weapons, nuclear installations, surgical implants, and other medical devices. "Critical Component" means any component of a High-Risk Device whose failure to perform can be reasonably expected to cause, directly or indirectly, the failure of the High-Risk Device, or to affect its safety or effectiveness. Cypress is not liable, in whole or in part, and you shall and hereby do release Cypress from any claim, damage, or other liability arising from any use of a Cypress product as a Critical Component in a High-Risk Device. You shall indemnify and hold Cypress, its directors, officers, employees, agents, affiliates, distributors, and assigns harmless from and against all claims, costs, damages, and expenses, arising out of any claim, including claims for product liability, personal injury or death, or property damage arising from any use of a Cypress product as a Critical Component in a High-Risk Device. Cypress products are not intended or authorized for use as a Critical Component in any High-Risk Device except to the limited extent that (i) Cypress's published data sheet for the product explicitly states Cypress has qualified the product for use in a specific High-Risk Device, or (ii) Cypress has given you advance written authorization to use the product as a Critical Component in the specific High-Risk Device and you have signed a separate indemnification agreement.

Cypress, the Cypress logo, Spansion, the Spansion logo, and combinations thereof, WICED, PSoC, CapSense, EZ-USB, F-RAM, and Traveo are trademarks or registered trademarks of Cypress in the United States and other countries. For a more complete list of Cypress trademarks, visit cypress.com. Other names and brands may be claimed as property of their respective owners.

Looking for pricing, stock, or lifecycle information?

Click below to explore more details on WIN SOURCE:

-  [View CYUSB3314-88LTXC on WIN SOURCE](#)
-  [Cypress Semiconductor Corp Information](#)

Optimize Your Supply Chain with WIN SOURCE Solutions

-  Global Sourcing Solution
-  Obsolete Management
-  Cost Control Management
-  Shortage Management
-  Alternative Solution
-  Excess Inventory Management