



## FEATURES

- Meets or Exceeds the Requirements of IBM® 360/370 Input/Output Interface Specification for 4.5-Mb/s Operation
- Single 5-V Supply
- Uncommitted Emitter-Follower Output Structure for Party-Line Operation
- Driver Output Short-Circuit Protection
- Driver Input/Receiver Output Compatible With TTL
- Receiver Input Resistance . . . 7.4 kΩ to 20 kΩ
- Ratio Specification for Propagation Delay Time, Low to High/High to Low

## DESCRIPTION/ ORDERING INFORMATION

The SN751730 triple line driver/receiver is specifically designed to meet the input/output interface specifications for IBM System 360/370. It also is compatible with standard TTL logic and supply voltage levels.

The low-impedance emitter-follower driver outputs of the SN751730 drive terminated lines, such as coaxial cable or twisted pair. Having the outputs uncommitted allows wired-OR logic to be performed in party-line applications. Output short-circuit protection is provided by an internal clamping network that turns on when the output voltage drops below approximately 2.5 V.

An open line affects the receiver input as does a low-level input voltage.

All the driver inputs and receiver outputs are in conventional TTL configuration and the gating can be used during power-up and power-down sequences to ensure that no noise is introduced to the line by pulling either DE1 or DE2 to a low level.

**D OR N PACKAGE**  
**(TOP VIEW)**

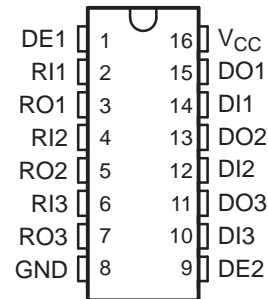

**DW PACKAGE**  
**(TOP VIEW)**

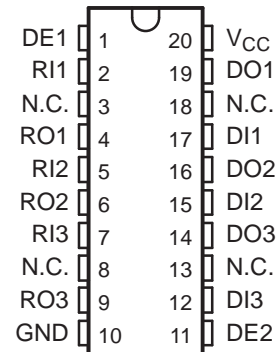

**NS PACKAGE**  
**(TOP VIEW)**

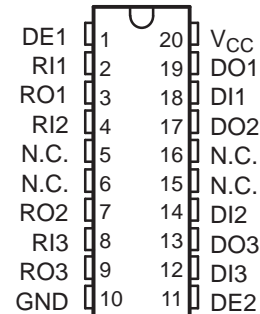

N.C. – No internal connection



Please be aware that an important notice concerning availability, standard warranty, and use in critical applications of Texas Instruments semiconductor products and disclaimers thereto appears at the end of this data sheet.

IBM is a registered trademark of International Business Machines Corporation.

**ORDERING INFORMATION**

T <sub>A</sub>	PACKAGE <sup>(1)(2)</sup>		ORDERABLE PART NUMBER	TOP-SIDE MARKING
0°C to 70°C	PDIP – N	Tube	SN751730N	SN751730N
	SOIC – D	Tube	SN751730D	SN751730
		Tape and reel	SN751730DR	
	SOIC – DW	Tube	SN751730DW	SN751730
		Tape and reel	SN751730DWR	
	SOP – NS	Tape and reel	SN751730NSR	SN751730

- (1) Package drawings, thermal data, and symbolization are available at [www.ti.com/packaging](http://www.ti.com/packaging).  
(2) For the most current package and ordering information, see the Package Option Addendum at the end of this document, or see the TI website at [www.ti.com](http://www.ti.com).

**FUNCTION TABLES**

**EACH DRIVER**

INPUTS			OUTPUT DO
DI	DE1	DE2	
L	X	X	L
X	L	X	L
X	X	L	L
H	H	H	H

**EACH DRIVER<sup>(1)</sup>**

INPUT RI	OUTPUT RO
L	H
H	L
Open	H

- (1) H = high level, L = low level, X = irrelevant

**LOGIC DIAGRAM (POSITIVE LOGIC)**

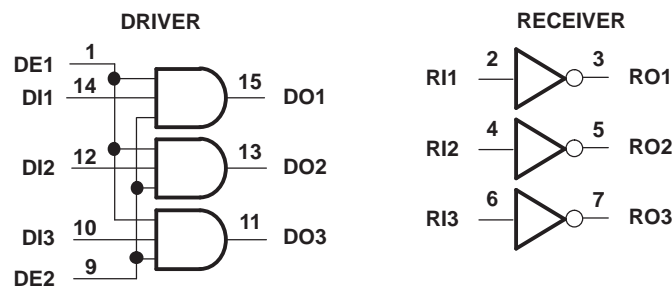

Pin numbers shown are for the D and N package only.

**EQUIVALENT SCHEMATICS OF DRIVER AND RECEIVER<sup>(1)</sup>**

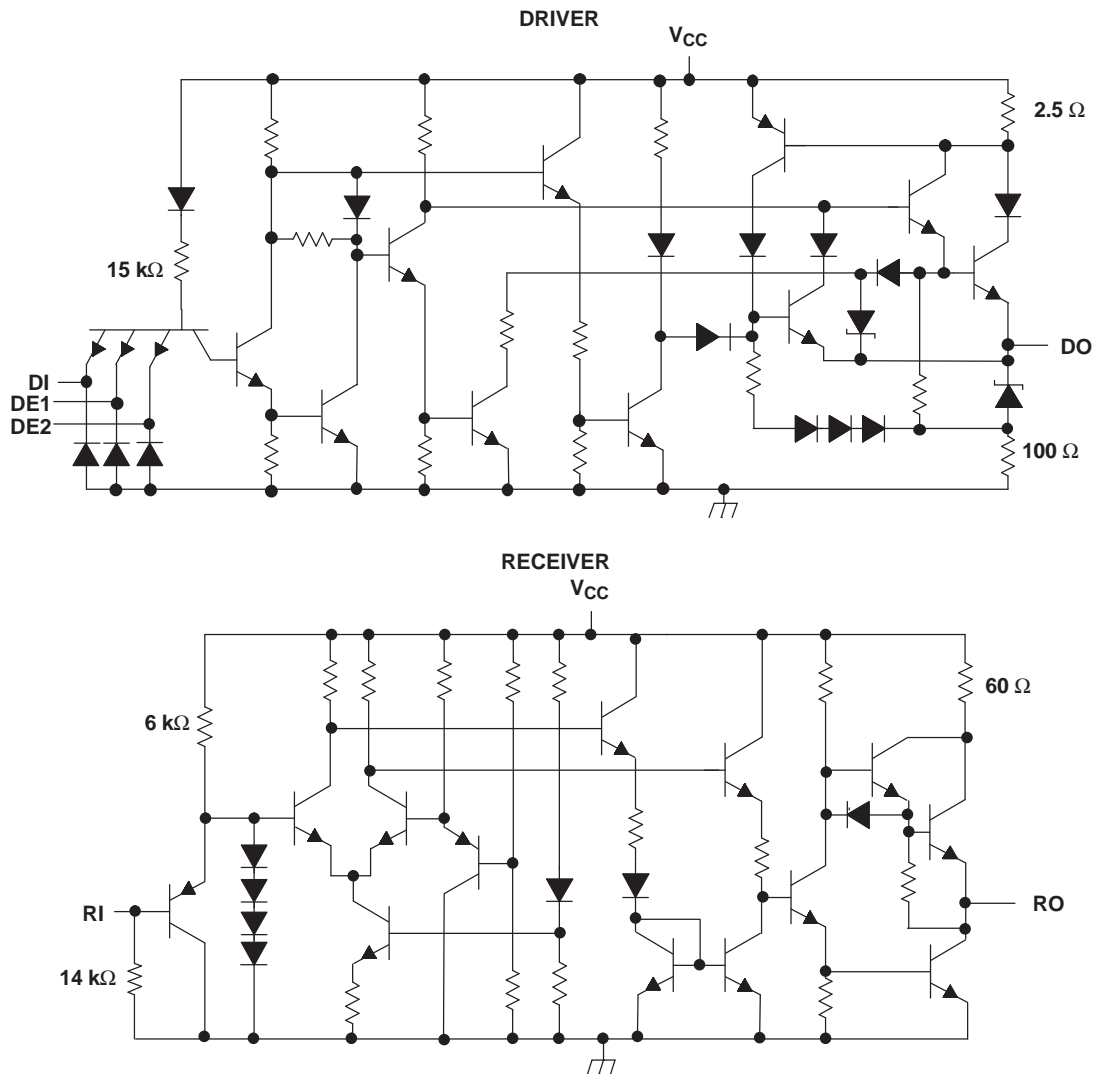

(1) All resistor values are nominal.

# SN751730 TRIPLE LINE DRIVER/RECEIVER

SLLS062E – MAY 1990 – REVISED AUGUST 2007

## Absolute Maximum Ratings<sup>(1)</sup>

over operating free-air temperature range (unless otherwise noted)

		MIN	MAX	UNIT	
V <sub>CC</sub>	Supply voltage <sup>(2)</sup>		7	V	
V <sub>I</sub>	Input voltage range	Driver	-0.5	7	V
		Receiver	-0.5	7	V
V <sub>O</sub>	Output voltage range	Driver	-0.5	7	V
	Enable input voltage range		-0.5	7	V
θ <sub>JA</sub>	Package thermal impedance <sup>(3)</sup>	D package		73	°C/W
		DW package		58	
		N package		67	
		NS package		60	
T <sub>J</sub>	Operating virtual junction temperature		150	°C	
	Lead temperature 1,6 mm (1/16 inch) from case for 10 s		260	°C	
T <sub>stg</sub>	Storage temperature range	-65	150	°C/W	

- (1) Stresses beyond those listed under "absolute maximum ratings" may cause permanent damage to the device. These are stress ratings only, and functional operation of the device at these or any other conditions beyond those indicated under "recommended operating conditions" is not implied. Exposure to absolute-maximum-rated conditions for extended periods may affect device reliability.
- (2) All voltage values are with respect to network ground terminal.
- (3) The package thermal impedance is calculated in accordance with JESD 51-7.

## Recommended Operating Conditions

		MIN	NOM	MAX	UNIT
V <sub>CC</sub>	Supply voltage	4.75	5	5.25	V
V <sub>IH</sub>	High-level input voltage	Driver, Enable	2		V
		Receiver	1.55		
V <sub>IL</sub>	Low-level input voltage	Driver, Enable		0.8	V
		Receiver		1.15	
T <sub>A</sub>	Operating free-air temperature	0		70	°C

## DRIVER SECTION

### Electrical Characteristics

over recommended ranges of supply voltage and operating free-air temperature (unless otherwise noted)

PARAMETER		TEST CONDITIONS		MIN	MAX	UNIT	
$V_{IK}$	Input clamp voltage	$V_{CC} = 4.75\text{ V}$ ,	$I_{IL} = -18\text{ mA}$		-1.5	V	
$V_{OH}$	High-level output voltage	$V_{CC} = 4.75\text{ V}$ ,	$I_{OH} = -59.3\text{ mA}$	$V_{IH} = 2\text{ V}$ ,	$T_A = 25^\circ\text{C}$	3.11	V
		$V_{CC} = 5.25\text{ V}$ ,	$I_{OH} = -78.1\text{ mA}$	$V_{IH} = 2\text{ V}$ ,		4.1	
		$V_{CC} = 4.75\text{ V}$ ,	$R_L = 51.4\ \Omega$	$V_{IH} = 2\text{ V}$ ,		3.05	
		$V_{CC} = 5.25\text{ V}$ ,	$R_L = 56.9\ \Omega$	$V_{IH} = 2\text{ V}$ ,		4.2	
$V_{ODH}$	Differential high-level output voltage	$R_L = 46.3\ \Omega$ or $56.9\ \Omega$			0.5	V	
$V_{OL}$	Low-level output voltage	$V_{CC} = 5.25\text{ V}$ ,	$V_{IL} = 0.8\text{ V}$ ,	$V_{IH} = 4.5\text{ V}$	$I_{OL} = -0.24\text{ mA}$	0.15	V
					$R_L = 56.9\ \Omega$	0.15	
$I_{IH}$	High-level input current	$V_{CC} = 5.25\text{ V}$ ,	$V_{IH} = 2.7\text{ V}$	DI	20	$\mu\text{A}$	
				DE	60		
$I_{IL}$	Low-level input current	$V_{CC} = 5.25\text{ V}$ ,	$V_{IH} = 0.4\text{ V}$	DI	-400	$\mu\text{A}$	
				DE	-1200		
$I_{OH}$	High-level output current	$V_{CC} = 4.75\text{ V}$ ,	$V_{OH} = 5\text{ V}$	$V_{IL} = 0$	100	$\mu\text{A}$	
				$V_{IH} = 4.5\text{ V}$	100		
$I_{OS}$	Short-circuit output current <sup>(1)</sup>	$V_{CC} = 5.25\text{ V}$	$V_{IH} = 4.5\text{ V}$		-30	mA	
$I_{CCH}$	Supply current (total package)	$V_{CC} = 5.25\text{ V}$ ,	No load	$V_{I(D)} = 4.5\text{ V}$ ,	$V_{I(R)} = 0$	47	mA
$I_{CCL}$				$V_{I(D)} = 0$ ,	$V_{I(R)} = 4.5\text{ V}$	80	

(1) Not more than one output should be shorted at a time, and duration of the short circuit should not exceed one second.

### Switching Characteristics

$V_{CC} = 5\text{ V} + 5\%$ ,  $T_A = 25^\circ\text{C}$

PARAMETER		TEST CONDITIONS		MIN	TYP	MAX	UNIT
$t_{PLH}$	Propagation delay time, low- to high-level output	$R_L = 47.5\ \Omega$ ,	See <a href="#">Figure 1</a>	6.5	12	18.5	ns
$t_{PHL}$	Propagation delay time, high- to low-level output			6.5	12	18.5	ns
$\Delta t_{pd}$	Differential propagation delay time <sup>(1)</sup>					10	ns
$t_r$	Output rise time	$V_{CC} = 5\text{ V}$ ,	$V_O = 0.15\text{ V}$ to $3.05\text{ V}$ ,	5	10		ns
$t_f$	Output fall time	$R_L = 47.5\ \Omega$ ,	$V_i$	5	13		ns
		See <a href="#">Figure 1</a>	$C_L = 10.2\text{ pF}$ ,				
SR	Slew rate	$V_O = 1\text{ V}$ to $3\text{ V}$ average,	$C_L = 10.2\text{ pF}$ ,			0.65	V/ns
		$R_L = 47.5\ \Omega$ ,	See <a href="#">Figure 1</a>				

(1)  $\Delta t_{pd} = |t_{PLH} - t_{PHL}|$

## RECEIVER SECTION

### Electrical Characteristics

over operating free-air temperature range (unless otherwise noted)

PARAMETER		TEST CONDITIONS		MIN	MAX	UNIT
$V_{OH}$	High-level output voltage	$V_{CC} = 4.75\text{ V}$ , $I_{OH} = -400\ \mu\text{A}$	$V_I = 1.15\text{ V}$ ,	2.7		V
$V_{OL}$	Low-level output voltage	$V_{CC} = 4.75\text{ V}$ , $V_{IH} = 1.55\text{ V}$	$I_{OL} = 8\text{ mA}$		0.5	V
			$I_{OL} = 4\text{ mA}$		0.4	
$r_i$	Input resistance	$V_{CC} = 0$ ,	$V_I = 0.15\text{ V to } 3.9\text{ V}$	7.4	20	k $\Omega$
$I_{IH}$	High-level input current	$V_{CC} = 4.75\text{ V}$ ,	$V_{IH} = 3.11\text{ V}$		0.42	mA
$I_{IL}$	Low-level input current	$V_{CC} = 5.25\text{ V}$ ,	$V_{IL} = 0.15\text{ V}$	-0.24	0.04	mA
$I_{OS}^{(1)}$	Short-circuit output current	$V_{CC} = 5.25\text{ V}$ ,	$V_{IL} = 0$	-20	-100	mA
$I_{CCH}$	Supply current (total package)	$V_{CC} = 5.25\text{ V}$ , No load	$V_{I(D)} = 4.5\text{ V}$ , $V_{I(R)} = 0$		47	mA
$I_{CCL}$			$V_{I(D)} = 0$ , $V_{I(R)} = 4.5\text{ V}$		80	

(1) Not more than one output should be shorted at a time, and duration of the short circuit should not exceed one second.

### Switching Characteristics

$V_{CC} = 5\text{ V} + 5\%$ ,  $T_A = 25^\circ\text{C}$

PARAMETER		TEST CONDITIONS	MIN	TYP	MAX	UNIT
$t_{PLH}$	Propagation delay time, low- to high-level output	$R_L = 2\text{ k}\Omega$ , $C_L = 15\text{ pF}$ , See <a href="#">Figure 2</a>	7.5	12	19.5	ns
$t_{PHL}$	Propagation delay time, high- to low-level output		7.5	12	19.5	ns
$\Delta t_{pd}^{(1)}$	Differential propagation delay time				10	ns

(1)  $\Delta t_{pd} = |t_{PLH} - t_{PHL}|$

PARAMETER MEASUREMENT INFORMATION

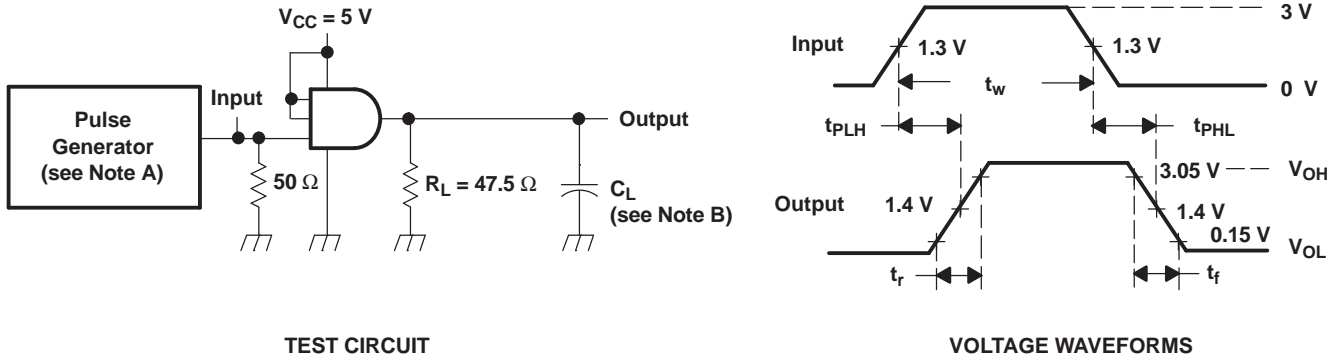

NOTES: A. The pulse generator has the following characteristics:  $Z_O \approx 50 \Omega$ ,  $t_w \leq 500$  ns,  $PRR \leq 1$  MHz,  $t_f \leq 6$  ns,  $t_r \leq 15$  ns.  
B.  $C_L$  includes probe and jig capacitance.

Figure 1. Driver Test Circuit and Voltage Waveforms

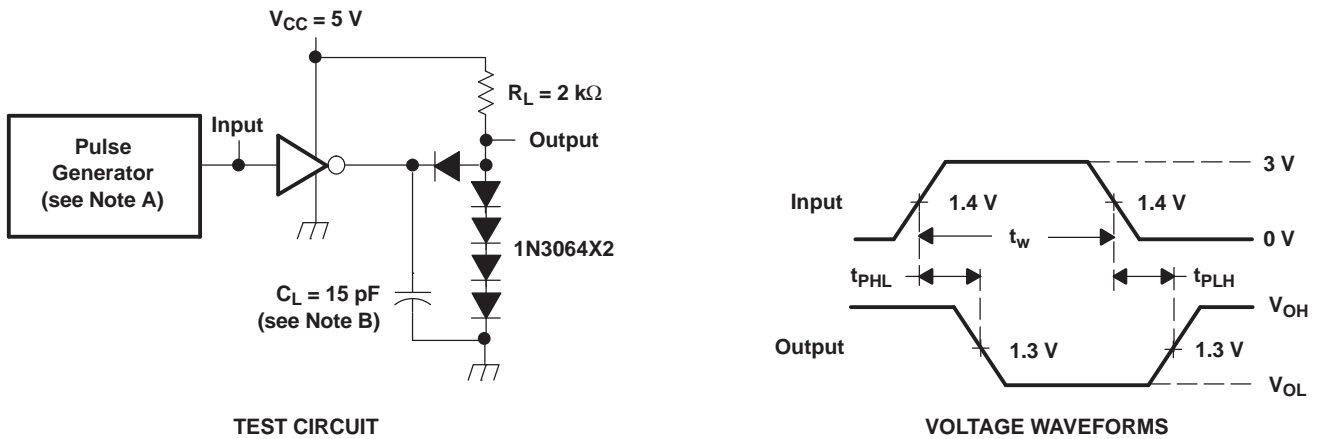

NOTES: A. The pulse generator has the following characteristics:  $Z_O \approx 50 \Omega$ ,  $t_w \leq 500$  ns,  $PRR \leq 1$  MHz,  $t_f \leq 10$  ns,  $t_r \leq 10$  ns.  
B.  $C_L$  includes probe and jig capacitance.

Figure 2. Receiver Test Circuit and Voltage Waveforms

**PACKAGING INFORMATION**

Orderable Device	Status (1)	Package Type	Package Drawing	Pins	Package Qty	Eco Plan (2)	Lead finish/ Ball material (6)	MSL Peak Temp (3)	Op Temp (°C)	Device Marking (4/5)	Samples
SN751730D	ACTIVE	SOIC	D	16	40	RoHS & Green	NIPDAU	Level-1-260C-UNLIM	0 to 70	SN751730	Samples
SN751730DE4	ACTIVE	SOIC	D	16	40	RoHS & Green	NIPDAU	Level-1-260C-UNLIM	0 to 70	SN751730	Samples
SN751730DWR	ACTIVE	SOIC	DW	20	2000	RoHS & Green	NIPDAU	Level-1-260C-UNLIM		SN751730	Samples
SN751730N	ACTIVE	PDIP	N	16	25	RoHS & Green	NIPDAU	N / A for Pkg Type	0 to 70	SN751730N	Samples

(1) The marketing status values are defined as follows:

**ACTIVE:** Product device recommended for new designs.

**LIFEBUY:** TI has announced that the device will be discontinued, and a lifetime-buy period is in effect.

**NRND:** Not recommended for new designs. Device is in production to support existing customers, but TI does not recommend using this part in a new design.

**PREVIEW:** Device has been announced but is not in production. Samples may or may not be available.

**OBSELETE:** TI has discontinued the production of the device.

(2) **RoHS:** TI defines "RoHS" to mean semiconductor products that are compliant with the current EU RoHS requirements for all 10 RoHS substances, including the requirement that RoHS substance do not exceed 0.1% by weight in homogeneous materials. Where designed to be soldered at high temperatures, "RoHS" products are suitable for use in specified lead-free processes. TI may reference these types of products as "Pb-Free".

**RoHS Exempt:** TI defines "RoHS Exempt" to mean products that contain lead but are compliant with EU RoHS pursuant to a specific EU RoHS exemption.

**Green:** TI defines "Green" to mean the content of Chlorine (Cl) and Bromine (Br) based flame retardants meet JS709B low halogen requirements of <=1000ppm threshold. Antimony trioxide based flame retardants must also meet the <=1000ppm threshold requirement.

(3) MSL, Peak Temp. - The Moisture Sensitivity Level rating according to the JEDEC industry standard classifications, and peak solder temperature.

(4) There may be additional marking, which relates to the logo, the lot trace code information, or the environmental category on the device.

(5) Multiple Device Markings will be inside parentheses. Only one Device Marking contained in parentheses and separated by a "-" will appear on a device. If a line is indented then it is a continuation of the previous line and the two combined represent the entire Device Marking for that device.

(6) Lead finish/Ball material - Orderable Devices may have multiple material finish options. Finish options are separated by a vertical ruled line. Lead finish/Ball material values may wrap to two lines if the finish value exceeds the maximum column width.

**Important Information and Disclaimer:**The information provided on this page represents TI's knowledge and belief as of the date that it is provided. TI bases its knowledge and belief on information provided by third parties, and makes no representation or warranty as to the accuracy of such information. Efforts are underway to better integrate information from third parties. TI has taken and

continues to take reasonable steps to provide representative and accurate information but may not have conducted destructive testing or chemical analysis on incoming materials and chemicals. TI and TI suppliers consider certain information to be proprietary, and thus CAS numbers and other limited information may not be available for release.

In no event shall TI's liability arising out of such information exceed the total purchase price of the TI part(s) at issue in this document sold by TI to Customer on an annual basis.

**TAPE AND REEL INFORMATION**

**QUADRANT ASSIGNMENTS FOR PIN 1 ORIENTATION IN TAPE**

\*All dimensions are nominal

Device	Package Type	Package Drawing	Pins	SPQ	Reel Diameter (mm)	Reel Width W1 (mm)	A0 (mm)	B0 (mm)	K0 (mm)	P1 (mm)	W (mm)	Pin1 Quadrant
SN751730DWR	SOIC	DW	20	2000	330.0	24.4	10.8	13.3	2.7	12.0	24.0	Q1

**TAPE AND REEL BOX DIMENSIONS**

\*All dimensions are nominal

Device	Package Type	Package Drawing	Pins	SPQ	Length (mm)	Width (mm)	Height (mm)
SN751730DWR	SOIC	DW	20	2000	367.0	367.0	45.0

**TUBE**

\*All dimensions are nominal

Device	Package Name	Package Type	Pins	SPQ	L (mm)	W (mm)	T (μm)	B (mm)
SN751730D	D	SOIC	16	40	507	8	3940	4.32
SN751730DE4	D	SOIC	16	40	507	8	3940	4.32
SN751730N	N	PDIP	16	25	506	13.97	11230	4.32

D (R-PDSO-G16)

PLASTIC SMALL OUTLINE



- NOTES:
- A. All linear dimensions are in inches (millimeters).
  - B. This drawing is subject to change without notice.
  - C. Body length does not include mold flash, protrusions, or gate burrs. Mold flash, protrusions, or gate burrs shall not exceed 0.006 (0,15) each side.
  - D. Body width does not include interlead flash. Interlead flash shall not exceed 0.017 (0,43) each side.
  - E. Reference JEDEC MS-012 variation AC.

N (R-PDIP-T\*\*)

PLASTIC DUAL-IN-LINE PACKAGE

16 PINS SHOWN



- NOTES:
- A. All linear dimensions are in inches (millimeters).
  - B. This drawing is subject to change without notice.
  - Falls within JEDEC MS-001, except 18 and 20 pin minimum body length (Dim A).
  - The 20 pin end lead shoulder width is a vendor option, either half or full width.

# DW0020A



# PACKAGE OUTLINE

## SOIC - 2.65 mm max height

SOIC



**NOTES:**

1. All linear dimensions are in millimeters. Dimensions in parenthesis are for reference only. Dimensioning and tolerancing per ASME Y14.5M.
2. This drawing is subject to change without notice.
3. This dimension does not include mold flash, protrusions, or gate burrs. Mold flash, protrusions, or gate burrs shall not exceed 0.15 mm per side.
4. This dimension does not include interlead flash. Interlead flash shall not exceed 0.43 mm per side.
5. Reference JEDEC registration MS-013.

# EXAMPLE BOARD LAYOUT

DW0020A

SOIC - 2.65 mm max height

SOIC



LAND PATTERN EXAMPLE  
SCALE:6X



SOLDER MASK DETAILS

4220724/A 05/2016

NOTES: (continued)

- 6. Publication IPC-7351 may have alternate designs.
- 7. Solder mask tolerances between and around signal pads can vary based on board fabrication site.

# EXAMPLE STENCIL DESIGN

DW0020A

SOIC - 2.65 mm max height

SOIC

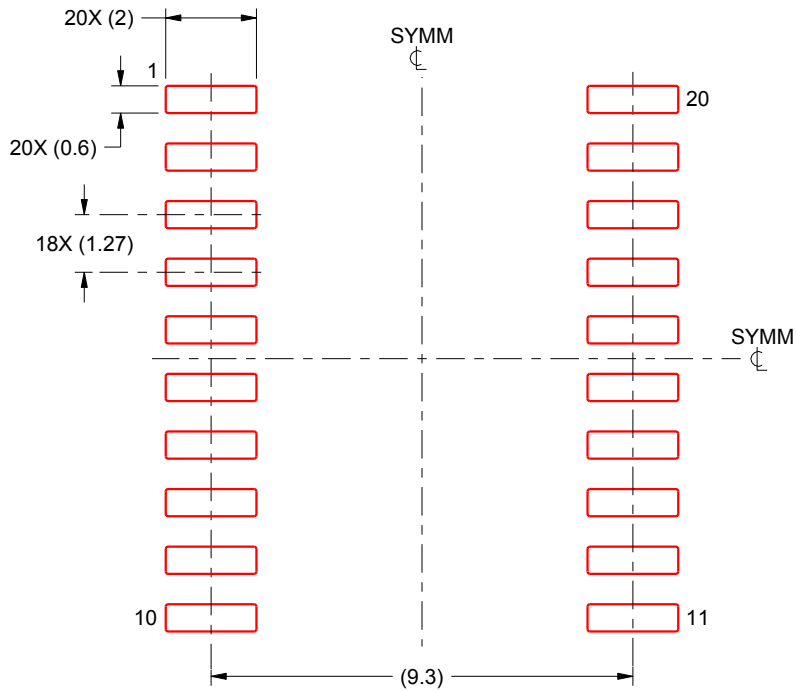

SOLDER PASTE EXAMPLE  
BASED ON 0.125 mm THICK STENCIL  
SCALE:6X

4220724/A 05/2016

NOTES: (continued)

8. Laser cutting apertures with trapezoidal walls and rounded corners may offer better paste release. IPC-7525 may have alternate design recommendations.
9. Board assembly site may have different recommendations for stencil design.

## IMPORTANT NOTICE AND DISCLAIMER

TI PROVIDES TECHNICAL AND RELIABILITY DATA (INCLUDING DATA SHEETS), DESIGN RESOURCES (INCLUDING REFERENCE DESIGNS), APPLICATION OR OTHER DESIGN ADVICE, WEB TOOLS, SAFETY INFORMATION, AND OTHER RESOURCES "AS IS" AND WITH ALL FAULTS, AND DISCLAIMS ALL WARRANTIES, EXPRESS AND IMPLIED, INCLUDING WITHOUT LIMITATION ANY IMPLIED WARRANTIES OF MERCHANTABILITY, FITNESS FOR A PARTICULAR PURPOSE OR NON-INFRINGEMENT OF THIRD PARTY INTELLECTUAL PROPERTY RIGHTS.

These resources are intended for skilled developers designing with TI products. You are solely responsible for (1) selecting the appropriate TI products for your application, (2) designing, validating and testing your application, and (3) ensuring your application meets applicable standards, and any other safety, security, regulatory or other requirements.

These resources are subject to change without notice. TI grants you permission to use these resources only for development of an application that uses the TI products described in the resource. Other reproduction and display of these resources is prohibited. No license is granted to any other TI intellectual property right or to any third party intellectual property right. TI disclaims responsibility for, and you will fully indemnify TI and its representatives against, any claims, damages, costs, losses, and liabilities arising out of your use of these resources.

TI's products are provided subject to [TI's Terms of Sale](#) or other applicable terms available either on [ti.com](https://www.ti.com) or provided in conjunction with such TI products. TI's provision of these resources does not expand or otherwise alter TI's applicable warranties or warranty disclaimers for TI products.

TI objects to and rejects any additional or different terms you may have proposed.

Mailing Address: Texas Instruments, Post Office Box 655303, Dallas, Texas 75265  
Copyright © 2024, Texas Instruments Incorporated

## Looking for pricing, stock, or lifecycle information?

Click below to explore more details on WIN SOURCE:

 [View SN751730DRG4 on WIN SOURCE](#)

 [Texas Instruments](#) Information

## Optimize Your Supply Chain with WIN SOURCE Solutions

-  Global Sourcing Solution
-  Obsolete Management
-  Cost Control Management
-  Shortage Management
-  Alternative Solution
-  Excess Inventory Management