



THE DATASHEET OF SN75LVDS31PWRG4



SN75LVDS31, SN75LVDS9638 HIGH-SPEED DIFFERENTIAL LINE DRIVERS

SLLS359C – JUNE 1999 – REVISED JUNE 2001

- Meets or Exceeds the Requirements of ANSI TIA/EIA-644 Standard
- Low-Voltage Differential Signaling With Typical Output Voltage of 350 mV and a 100-Ω Load
- Signaling Rates up to 155 Mbps
- Operates From a Single 3.3-V Supply
- Driver at High Impedance When Disabled or With $V_{CC} = 0$
- Low-Voltage TTL (LVTTTL) Logic Input Levels
- Characterized For Operation From 0°C to 70°C

description

The SN75LVDS31 and SN75LVDS9638 are differential line drivers that implement the electrical characteristics of low-voltage differential signaling (LVDS). This signaling technique lowers the output voltage levels of 5-V differential standard levels (such as TIA/EIA-422B) to reduce the power, increase the switching speeds, and allow operation with a 3.3-V supply rail. Any of the four current-mode drivers will deliver a minimum differential output voltage magnitude of 247 mV into a 100-Ω load when enabled.

The intended application of these devices and signaling technique is for point-to-point baseband data transmission over controlled impedance media of approximately 100 Ω. The transmission media may be printed-circuit board traces, backplanes, or cables. The ultimate rate and distance of data transfer is dependent upon the attenuation characteristics of the media and the noise coupling to the environment.

The SN75LVDS31 and SN75LVDS9638 are characterized for operation from 0°C to 70°C.

SN75LVDS31D (Marked as 75LVDS31)
SN75LVDS31PW (Marked as DS31)
(TOP VIEW)

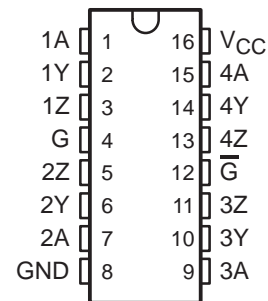

SN75LVDS9638D (Marked as DF638 or 7L9638)
SN75LVDS9638DGK (Marked as AXK)
(TOP VIEW)

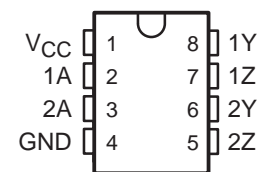

Please be aware that an important notice concerning availability, standard warranty, and use in critical applications of Texas Instruments semiconductor products and disclaimers thereto appears at the end of this data sheet.

PRODUCTION DATA information is current as of publication date. Products conform to specifications per the terms of Texas Instruments standard warranty. Production processing does not necessarily include testing of all parameters.

 **TEXAS
INSTRUMENTS**

POST OFFICE BOX 655303 • DALLAS, TEXAS 75265

Copyright © 2001, Texas Instruments Incorporated

SN75LVDS31, SN75LVDS9638 HIGH-SPEED DIFFERENTIAL LINE DRIVERS

SLLS359C – JUNE 1999 – REVISED JUNE 2001

logic symbol†

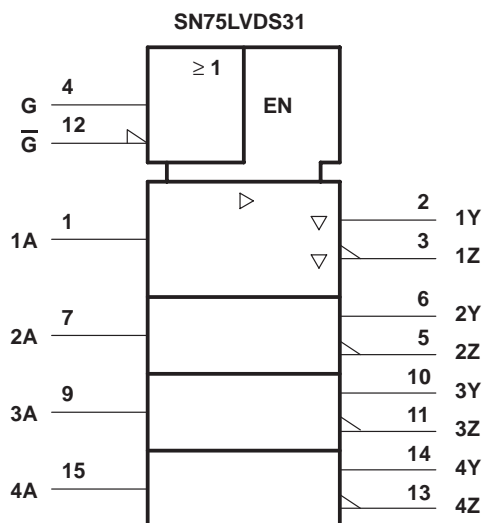

'LVDS31 logic diagram (positive logic)

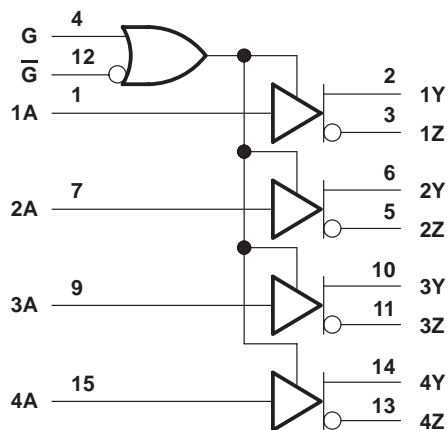

† This symbol is in accordance with ANSI/IEEE Std 91-1984 and IEC Publication 617-12.

logic symbol†

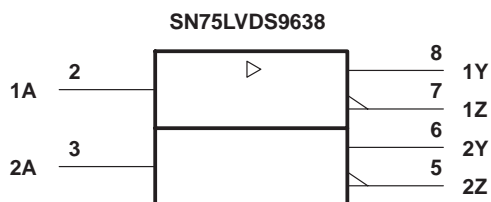

'LVDS9638 logic diagram (positive logic)

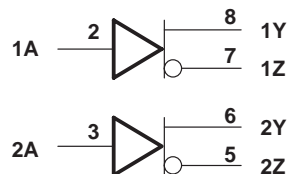

† This symbol is in accordance with ANSI/IEEE Std 91-1984 and IEC Publication 617-12.

Function Tables

SN75LVDS31

INPUT A	ENABLES		OUTPUTS	
	G	\bar{G}	Y	Z
H	H	X	H	L
L	H	X	L	H
H	X	L	H	L
L	X	L	L	H
X	L	H	Z	Z
Open	H	X	L	H
Open	X	L	L	H

H = high level, L = low level, X = irrelevant, Z = high impedance (off)

SN75LVDS9638

INPUT A	OUTPUTS	
	Y	Z
H	H	L
L	L	H
OPEN	L	H

H = high level, L = low level

equivalent input and output schematic diagrams

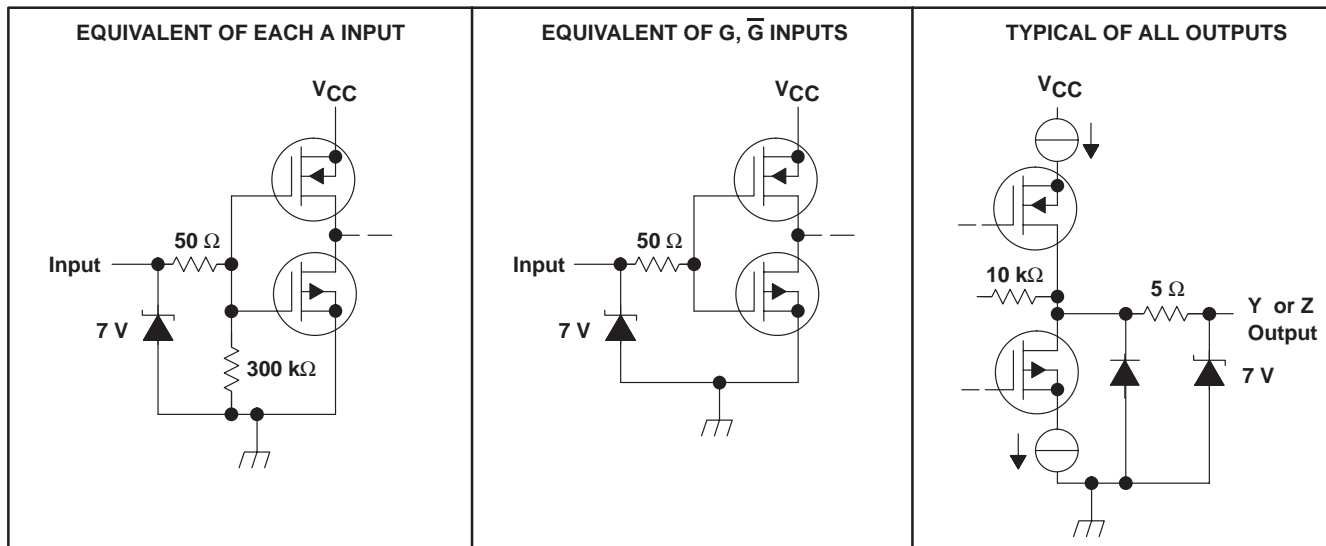

SN75LVDS31, SN75LVDS9638 HIGH-SPEED DIFFERENTIAL LINE DRIVERS

SLLS359C – JUNE 1999 – REVISED JUNE 2001

absolute maximum ratings over operating free-air temperature range (unless otherwise noted)†

Supply voltage range, V_{CC} (see Note 1)	-0.5 V to 4 V
Input voltage range: Inputs	-0.5 V to $V_{CC} + 0.5$ V
Y or Z	-0.5 V to 4 V
Continuous total power dissipation	See Dissipation Rating Table
Storage temperature range, T_{stg}	-65°C to 150°C
Lead temperature 1,6 mm (1/16 inch) from case for 10 seconds	260°C

† Stresses beyond those listed under “absolute maximum ratings” may cause permanent damage to the device. These are stress ratings only, and functional operation of the device at these or any other conditions beyond those indicated under “recommended operating conditions” is not implied. Exposure to absolute-maximum-rated conditions for extended periods may affect device reliability.

NOTE 1: All voltages, except differential I/O bus voltages, are with respect to the network ground terminal.

DISSIPATION RATING TABLE

PACKAGE	$T_A \leq 25^\circ\text{C}$ POWER RATING	DERATING FACTOR‡ ABOVE $T_A = 25^\circ\text{C}$	$T_A = 70^\circ\text{C}$ POWER RATING
D (8)	725 mW	5.8 mW/°C	464 mW
D (16)	950 mW	7.6 mW/°C	608 mW
PW	774 mW	6.2 mW/°C	496 mW
DGK	425 mW	3.4 mW/°C	272 mW

‡ This is the inverse of the junction-to-ambient thermal resistance when board-mounted and with no air flow.

recommended operating conditions

	MIN	NOM	MAX	UNIT
Supply voltage, V_{CC}	3	3.3	3.6	V
High-level input voltage, V_{IH}	2			V
Low-level input voltage, V_{IL}			0.8	V
Operating free-air temperature, T_A	0		70	°C



SN75LVDS31, SN75LVDS9638 HIGH-SPEED DIFFERENTIAL LINE DRIVERS

SLLS359C – JUNE 1999 – REVISED JUNE 2001

electrical characteristics over recommended operating conditions (unless otherwise noted)

PARAMETER		TEST CONDITIONS	SN75LVDS31, SN75LVDS9638			UNIT	
			MIN	TYP†	MAX		
V _{OD}	Differential output voltage magnitude	R _L = 100 Ω, See Figure 2	247	340	454	mV	
ΔV _{OD}	Change in differential output voltage magnitude between logic states		-50		50	mV	
ΔV _{OC(SS)}	Change in steady-state common-mode output voltage between logic states	See Figure 3	1.125	1.2	1.375	V	
V _{OC(SS)}	Steady-state common-mode output voltage		-50		50	mV	
V _{OC(PP)}	Peak-to-peak common-mode output voltage			50	150	mV	
I _{CC}	Supply current	V _I = 0.8 V or 2 V, Enabled, No load	SN75LVDS31		9	20	mA
			SN75LVDS9638		25	35	mA
		V _I = 0 or V _{CC} , Disabled	SN75LVDS31		0.25	1	mA
			SN75LVDS9638		4.7	8	mA
			SN75LVDS9638		9	13	mA
I _{IH}	High-level input current	V _{IH} = 2		4	20	μA	
I _{IL}	Low-level input current	V _{IL} = 0.8 V		0.1	10	μA	
I _{OS}	Short-circuit output current	V _{O(Y)} or V _{O(Z)} = 0		-4	-24	mA	
		V _{OD} = 0			±12	mA	
I _{OZ}	High-impedance output current	V _O = 0 or 2.4 V			±1	μA	
I _{O(OFF)}	Power-off output current	V _{CC} = 0, V _O = 2.4 V			±1	μA	
C _I	Input capacitance			3		pF	

† All typical values are at T_A = 25°C and with V_{CC} = 3.3 V.

switching characteristics over recommended operating conditions (unless otherwise noted)

PARAMETER		TEST CONDITIONS	SN75LVDS31, SN75LVDS9638			UNIT
			MIN	TYP†	MAX	
t _{pLH}	Propagation delay time, low-to-high-level output	R _L = 100 Ω, C _L = 10 pF, See Figure 2			6	ns
t _{pHL}	Propagation delay time, high-to-low-level output				6	ns
t _r	Differential output signal rise time (20% to 80%)		0.5	1.2		ns
t _f	Differential output signal fall time (80% to 20%)		0.5	1.2		ns
t _{sk(p)}	Pulse skew ((t _{pHL} - t _{pLH}))‡				0.6	ns
t _{sk(o)}	Channel-to-channel output skew§				0.6	ns
t _{sk(pp)}	Part-to-part skew¶				1	ps
t _{pZH}	Propagation delay time, high-impedance-to-high-level output	See Figure 4			25	ns
t _{pZL}	Propagation delay time, high-impedance-to-low-level output				25	ns
t _{pHZ}	Propagation delay time, high-level-to-high-impedance output				25	ns
t _{pLZ}	Propagation delay time, low-level-to-high-impedance output				25	ns

† All typical values are at T_A = 25°C and with V_{CC} = 3.3 V.

‡ t_{sk(p)} is the magnitude of the time difference between the high-to-low and low-to-high propagation delay times at an output.

§ t_{sk(o)} is the magnitude of the time difference between the outputs of a single device with all of their inputs connected together.

¶ t_{sk(pp)} is the magnitude of the difference in propagation delay times between any specified terminals of two devices when both devices operate with the same supply voltages, same temperature, and have identical packages and test circuits.



SN75LVDS31, SN75LVDS9638 HIGH-SPEED DIFFERENTIAL LINE DRIVERS

SLLS359C – JUNE 1999 – REVISED JUNE 2001

PARAMETER MEASUREMENT INFORMATION

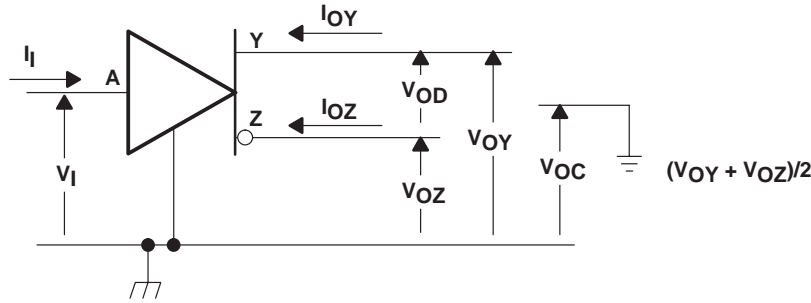
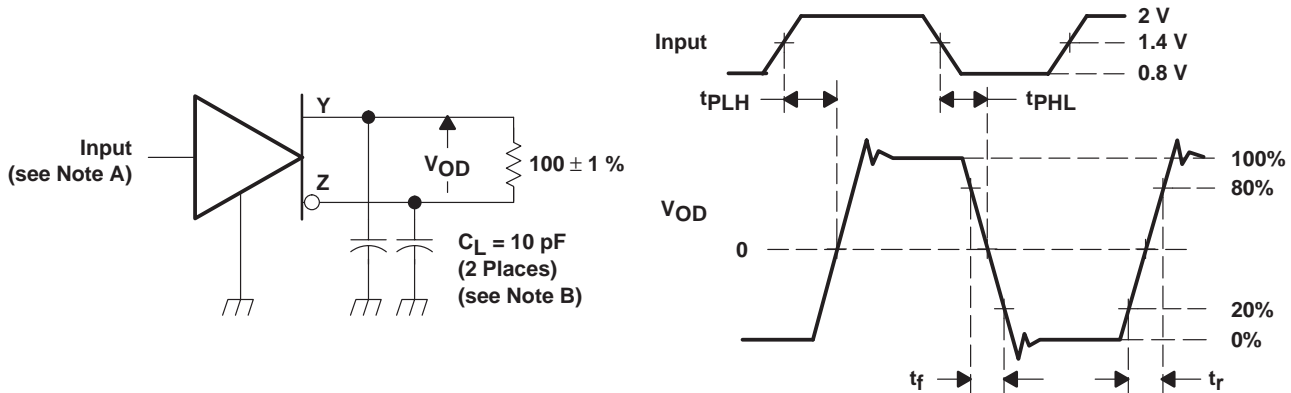
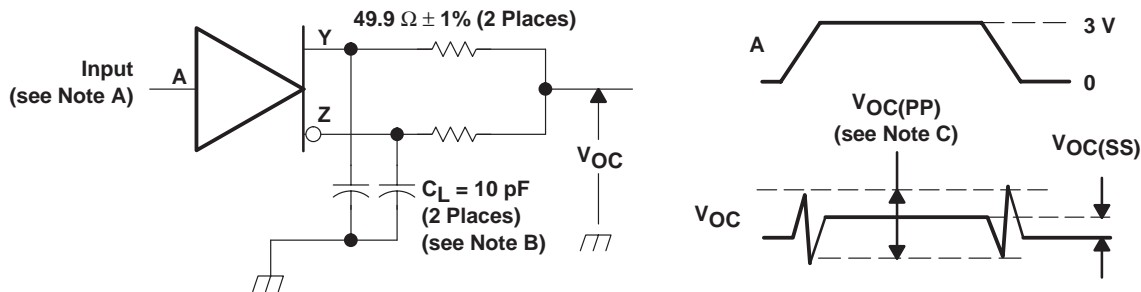

Figure 1. Voltage and Current Definitions



- NOTES: A. All input pulses are supplied by a generator having the following characteristics: t_r or $t_f \leq 1$ ns, pulse repetition rate (PRR) = 50 Mpps, pulse width = 10 ± 0.2 ns.
B. C_L includes instrumentation and fixture capacitance within 6 mm of the D.U.T.

Figure 2. Test Circuit, Timing, and Voltage Definitions for the Differential Output Signal



- NOTES: A. All input pulses are supplied by a generator having the following characteristics: t_r or $t_f \leq 1$ ns, pulse repetition rate (PRR) = 50 Mpps, pulse width = 10 ± 0.2 ns.
B. C_L includes instrumentation and fixture capacitance within 6 mm of the D.U.T.
C. The measurement of $V_{OC(PP)}$ is made on test equipment with a -3 dB bandwidth of at least 300 MHz.

Figure 3. Test Circuit and Definitions for the Driver Common-Mode Output Voltage

PARAMETER MEASUREMENT INFORMATION

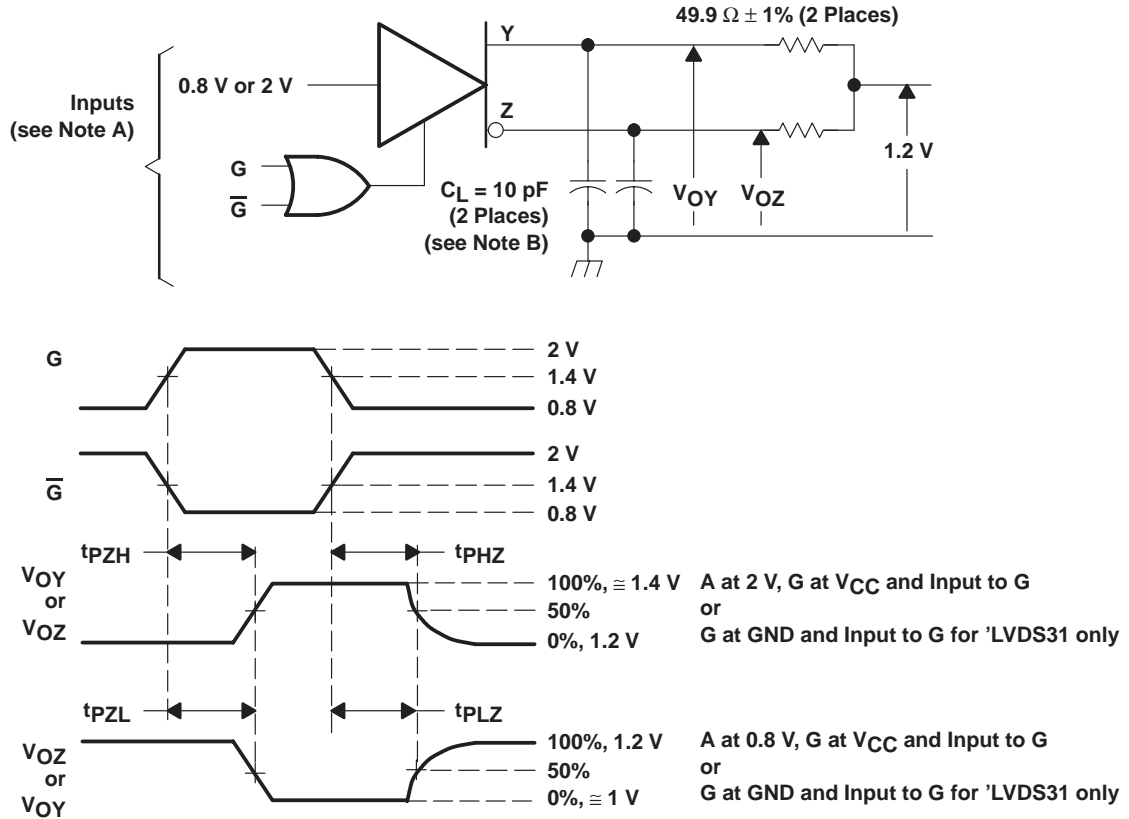

- NOTES: A. All input pulses are supplied by a generator having the following characteristics: t_r or $t_f < 1 \text{ ns}$, pulse repetition rate (PRR) = 0.5 Mpps , pulse width = $500 \pm 10 \text{ ns}$.
B. C_L includes instrumentation and fixture capacitance within 6 mm of the D.U.T.

Figure 4. Enable and Disable Time Circuit and Definitions

SN75LVDS31, SN75LVDS9638 HIGH-SPEED DIFFERENTIAL LINE DRIVERS

SLLS359C – JUNE 1999 – REVISED JUNE 2001

APPLICATIONS INFORMATION

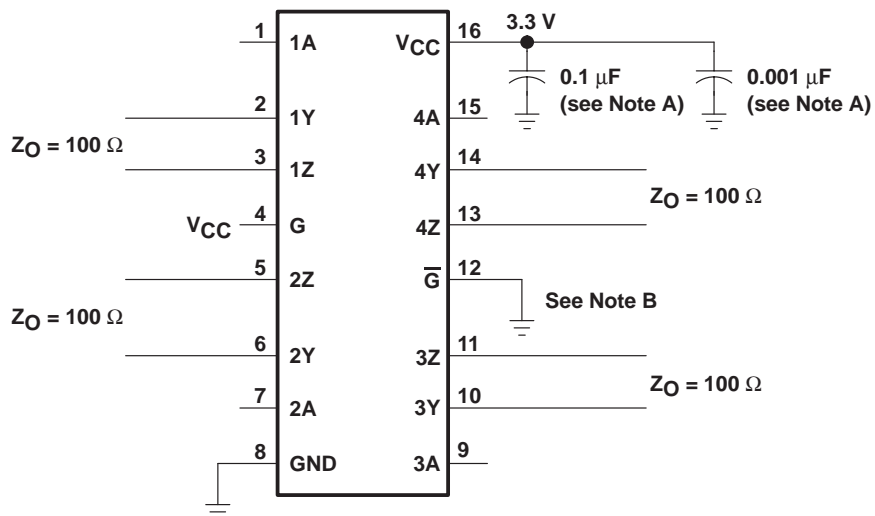

- NOTES: A. Place a 0.1 μF and a 0.001 μF Z5U ceramic, mica or polystyrene dielectric, 0805 size, chip capacitor between V_{CC} and the ground plane. The capacitors should be located as close as possible to the device terminals.
B. Unused enable inputs should be tied to V_{CC} or GND as appropriate.

Figure 5. Typical Application Circuit Schematic

APPLICATIONS INFORMATION

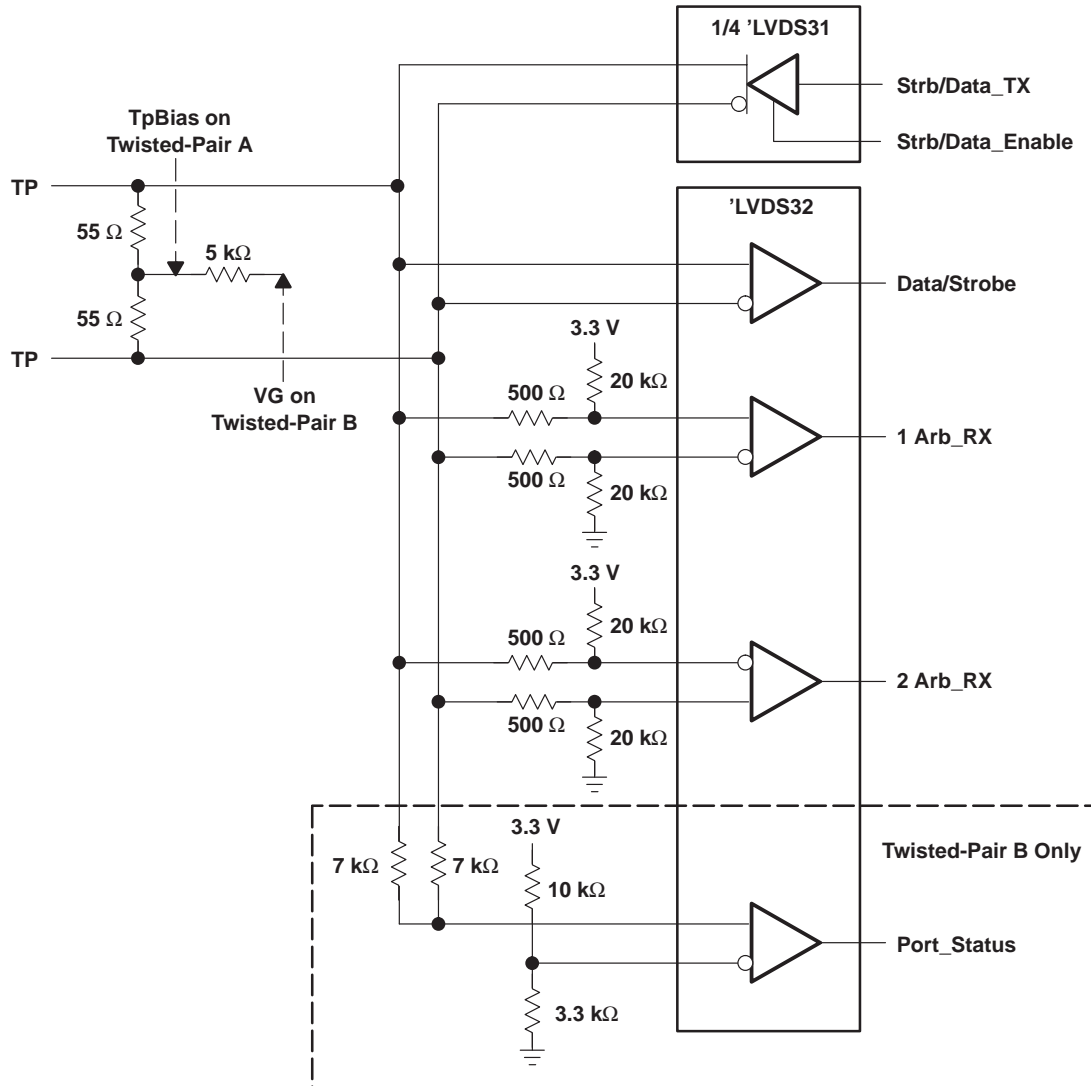

- NOTES: A. Resistors are leadless thick-film (0603) 5% tolerance.
 B. Decoupling capacitance is not shown but recommended.
 C. V_{CC} is 3 V to 3.6 V.
 D. The differential output voltage of the 'LVDS31 can exceed that specified by IEEE1394.

Figure 6. 100 Mbps IEEE1394 Transceiver

SN75LVDS31, SN75LVDS9638 HIGH-SPEED DIFFERENTIAL LINE DRIVERS

SLLS359C – JUNE 1999 – REVISED JUNE 2001

APPLICATIONS INFORMATION

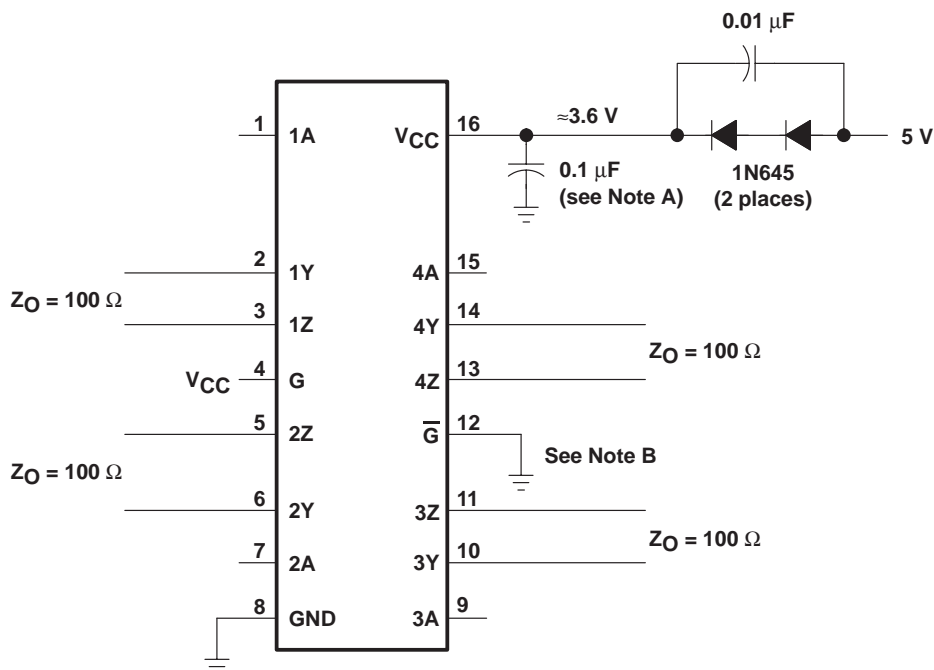

NOTE A: Place a 0.1 μF Z5U ceramic, mica or polystyrene dielectric, 0805 size, chip capacitor between V_{CC} and the ground plane. The capacitor should be located as close as possible to the device terminals.

Figure 7. Operation With a 5-V Supply

related information

IBIS modeling is available for this device. Please contact the local TI sales office or the TI Web site at www.ti.com for more information.

For more application guidelines, please see the following documents:

- *Low-Voltage Differential Signalling Design Notes* (TI literature number SLLA014)
- *Interface Circuits for TIA/EIA-644 (LVDS)* (TI literature number SLLA038)
- *Reducing EMI With LVDS* (TI literature number SLLA030)
- *Slew Rate Control of LVDS Circuits* (TI literature number SLLA034)
- *Using an LVDS Receiver With RS-422 Data* (TI literature number SLLA031)
- *Evaluating the LVDS EVM* (TI literature number SLLA033)

SN75LVDS31, SN75LVDS9638 HIGH-SPEED DIFFERENTIAL LINE DRIVERS

SLLS359C – JUNE 1999 – REVISED JUNE 2001

MECHANICAL INFORMATION

D (R-PDSO-G**)

PLASTIC SMALL-OUTLINE PACKAGE

14 PIN SHOWN

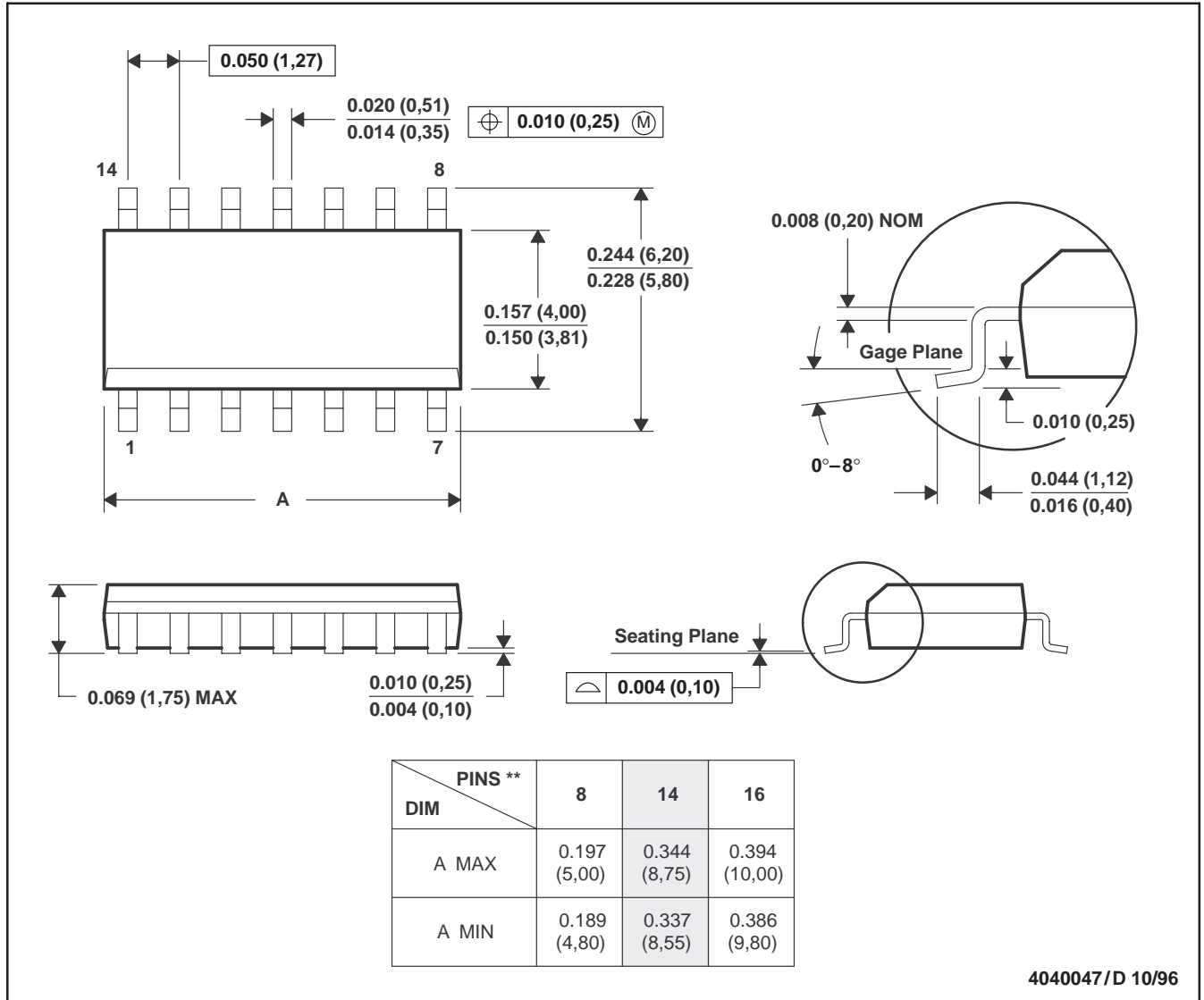

- NOTES: A. All linear dimensions are in inches (millimeters).
 B. This drawing is subject to change without notice.
 C. Body dimensions do not include mold flash or protrusion, not to exceed 0.006 (0,15).
 D. Falls within JEDEC MS-012

SN75LVDS31, SN75LVDS9638 HIGH-SPEED DIFFERENTIAL LINE DRIVERS

SLLS359C – JUNE 1999 – REVISED JUNE 2001

MECHANICAL INFORMATION

DGK (R-PDSO-G8)

PLASTIC SMALL-OUTLINE PACKAGE

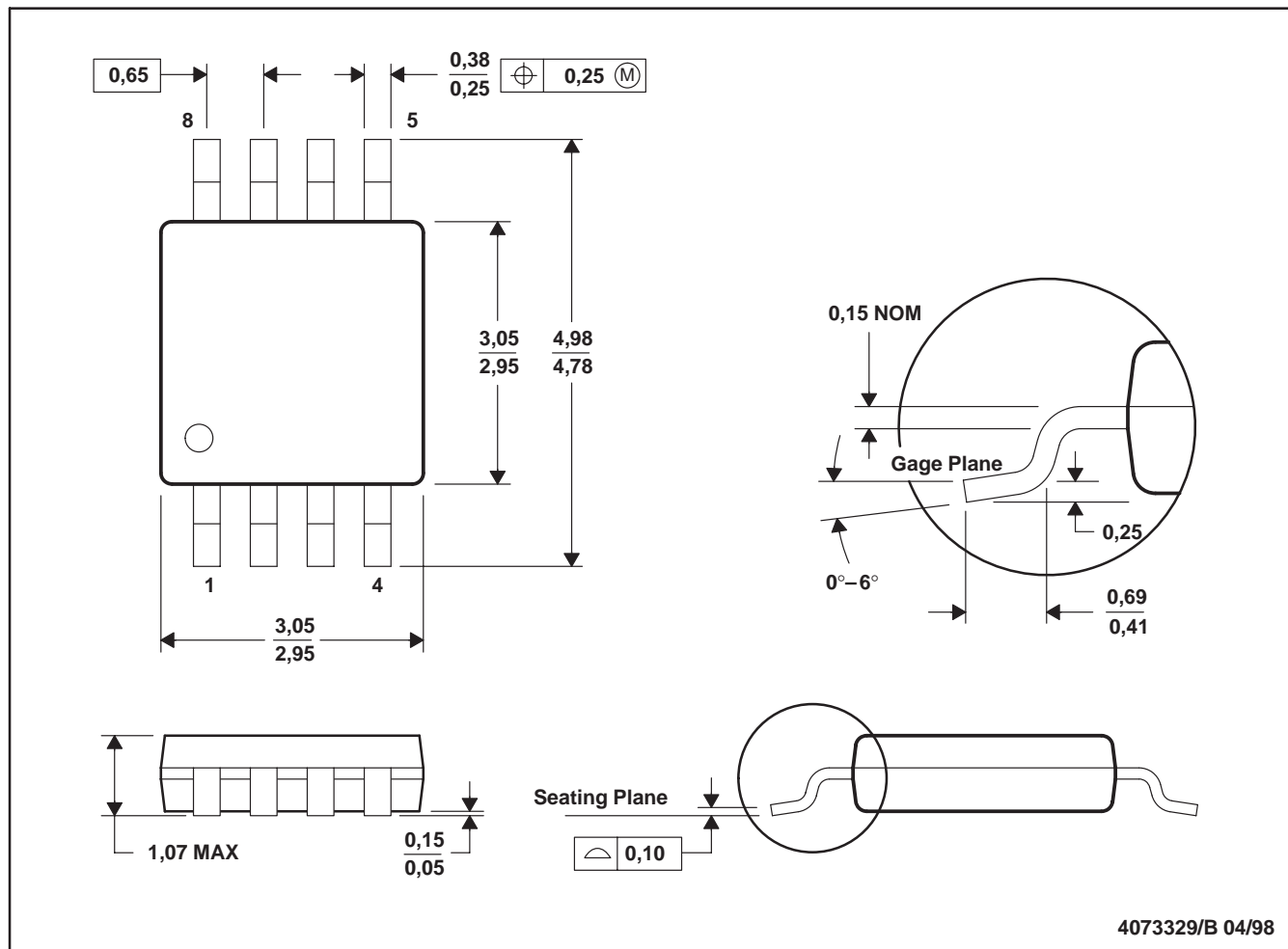

4073329/B 04/98

- NOTES:
- A. All linear dimensions are in millimeters.
 - B. This drawing is subject to change without notice.
 - C. Body dimensions do not include mold flash or protrusion.
 - D. Falls within JEDEC MO-187



POST OFFICE BOX 655303 • DALLAS, TEXAS 75265

MECHANICAL INFORMATION

PW (R-PDSO-G**)

PLASTIC SMALL-OUTLINE PACKAGE

14 PINS SHOWN

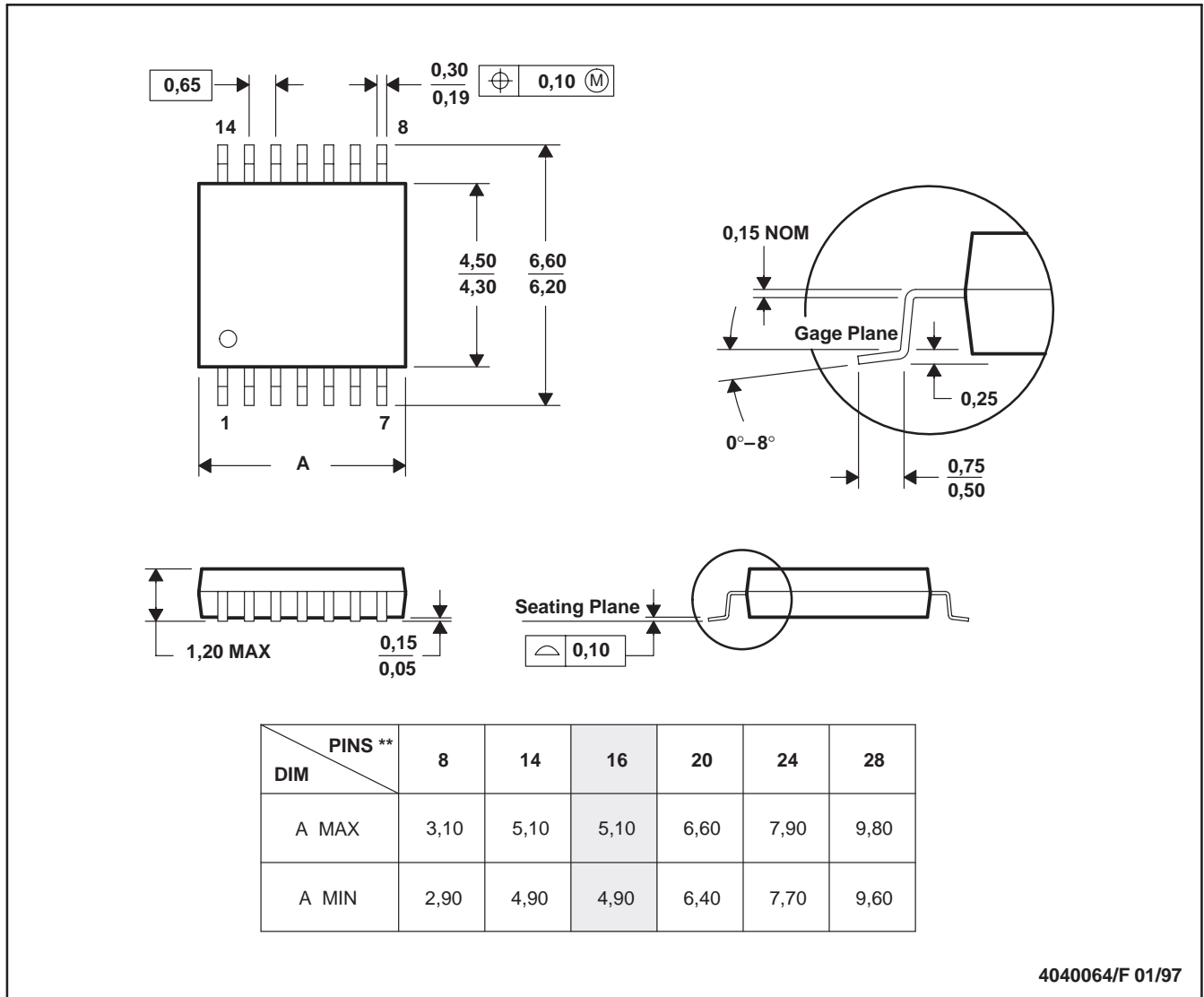

- NOTES: A. All linear dimensions are in millimeters.
 B. This drawing is subject to change without notice.
 C. Body dimensions do not include mold flash or protrusion not to exceed 0,15.
 D. Falls within JEDEC MO-153

PACKAGING INFORMATION

Orderable Device	Status (1)	Package Type	Package Drawing	Pins	Package Qty	Eco Plan (2)	Lead finish/ Ball material (6)	MSL Peak Temp (3)	Op Temp (°C)	Device Marking (4/5)	Samples
SN75LVDS31D	ACTIVE	SOIC	D	16	40	RoHS & Green	NIPDAU	Level-1-260C-UNLIM	0 to 70	75LVDS31	Samples
SN75LVDS31DR	ACTIVE	SOIC	D	16	2500	RoHS & Green	NIPDAU	Level-1-260C-UNLIM	0 to 70	75LVDS31	Samples
SN75LVDS31PW	ACTIVE	TSSOP	PW	16	90	RoHS & Green	NIPDAU	Level-1-260C-UNLIM	0 to 70	DS31	Samples
SN75LVDS9638D	ACTIVE	SOIC	D	8	75	RoHS & Green	NIPDAU	Level-1-260C-UNLIM	0 to 70	DF638	Samples
SN75LVDS9638DGK	ACTIVE	VSSOP	DGK	8	80	RoHS & Green	NIPDAU	Level-1-260C-UNLIM	0 to 70	AXK	Samples

(1) The marketing status values are defined as follows:

ACTIVE: Product device recommended for new designs.

LIFEBUY: TI has announced that the device will be discontinued, and a lifetime-buy period is in effect.

NRND: Not recommended for new designs. Device is in production to support existing customers, but TI does not recommend using this part in a new design.

PREVIEW: Device has been announced but is not in production. Samples may or may not be available.

OBSOLETE: TI has discontinued the production of the device.

(2) **RoHS:** TI defines "RoHS" to mean semiconductor products that are compliant with the current EU RoHS requirements for all 10 RoHS substances, including the requirement that RoHS substance do not exceed 0.1% by weight in homogeneous materials. Where designed to be soldered at high temperatures, "RoHS" products are suitable for use in specified lead-free processes. TI may reference these types of products as "Pb-Free".

RoHS Exempt: TI defines "RoHS Exempt" to mean products that contain lead but are compliant with EU RoHS pursuant to a specific EU RoHS exemption.

Green: TI defines "Green" to mean the content of Chlorine (Cl) and Bromine (Br) based flame retardants meet JS709B low halogen requirements of <=1000ppm threshold. Antimony trioxide based flame retardants must also meet the <=1000ppm threshold requirement.

(3) MSL, Peak Temp. - The Moisture Sensitivity Level rating according to the JEDEC industry standard classifications, and peak solder temperature.

(4) There may be additional marking, which relates to the logo, the lot trace code information, or the environmental category on the device.

(5) Multiple Device Markings will be inside parentheses. Only one Device Marking contained in parentheses and separated by a "~" will appear on a device. If a line is indented then it is a continuation of the previous line and the two combined represent the entire Device Marking for that device.

(6) Lead finish/Ball material - Orderable Devices may have multiple material finish options. Finish options are separated by a vertical ruled line. Lead finish/Ball material values may wrap to two lines if the finish value exceeds the maximum column width.

Important Information and Disclaimer: The information provided on this page represents TI's knowledge and belief as of the date that it is provided. TI bases its knowledge and belief on information provided by third parties, and makes no representation or warranty as to the accuracy of such information. Efforts are underway to better integrate information from third parties. TI has taken and continues to take reasonable steps to provide representative and accurate information but may not have conducted destructive testing or chemical analysis on incoming materials and chemicals. TI and TI suppliers consider certain information to be proprietary, and thus CAS numbers and other limited information may not be available for release.

In no event shall TI's liability arising out of such information exceed the total purchase price of the TI part(s) at issue in this document sold by TI to Customer on an annual basis.

OTHER QUALIFIED VERSIONS OF SN75LVDS31 :

- Military: [SN55LVDS31](#)

NOTE: Qualified Version Definitions:

- Military - QML certified for Military and Defense Applications

TAPE AND REEL INFORMATION

QUADRANT ASSIGNMENTS FOR PIN 1 ORIENTATION IN TAPE

*All dimensions are nominal

Device	Package Type	Package Drawing	Pins	SPQ	Reel Diameter (mm)	Reel Width W1 (mm)	A0 (mm)	B0 (mm)	K0 (mm)	P1 (mm)	W (mm)	Pin1 Quadrant
SN75LVDS31DR	SOIC	D	16	2500	330.0	16.4	6.5	10.3	2.1	8.0	16.0	Q1

TAPE AND REEL BOX DIMENSIONS

*All dimensions are nominal

Device	Package Type	Package Drawing	Pins	SPQ	Length (mm)	Width (mm)	Height (mm)
SN75LVDS31DR	SOIC	D	16	2500	340.5	336.1	32.0

TUBE

*All dimensions are nominal

Device	Package Name	Package Type	Pins	SPQ	L (mm)	W (mm)	T (μm)	B (mm)
SN75LVDS31D	D	SOIC	16	40	507	8	3940	4.32
SN75LVDS31PW	PW	TSSOP	16	90	530	10.2	3600	3.5
SN75LVDS9638D	D	SOIC	8	75	505.46	6.76	3810	4

IMPORTANT NOTICE AND DISCLAIMER

TI PROVIDES TECHNICAL AND RELIABILITY DATA (INCLUDING DATA SHEETS), DESIGN RESOURCES (INCLUDING REFERENCE DESIGNS), APPLICATION OR OTHER DESIGN ADVICE, WEB TOOLS, SAFETY INFORMATION, AND OTHER RESOURCES "AS IS" AND WITH ALL FAULTS, AND DISCLAIMS ALL WARRANTIES, EXPRESS AND IMPLIED, INCLUDING WITHOUT LIMITATION ANY IMPLIED WARRANTIES OF MERCHANTABILITY, FITNESS FOR A PARTICULAR PURPOSE OR NON-INFRINGEMENT OF THIRD PARTY INTELLECTUAL PROPERTY RIGHTS.

These resources are intended for skilled developers designing with TI products. You are solely responsible for (1) selecting the appropriate TI products for your application, (2) designing, validating and testing your application, and (3) ensuring your application meets applicable standards, and any other safety, security, regulatory or other requirements.

These resources are subject to change without notice. TI grants you permission to use these resources only for development of an application that uses the TI products described in the resource. Other reproduction and display of these resources is prohibited. No license is granted to any other TI intellectual property right or to any third party intellectual property right. TI disclaims responsibility for, and you will fully indemnify TI and its representatives against, any claims, damages, costs, losses, and liabilities arising out of your use of these resources.

TI's products are provided subject to [TI's Terms of Sale](#) or other applicable terms available either on [ti.com](https://www.ti.com) or provided in conjunction with such TI products. TI's provision of these resources does not expand or otherwise alter TI's applicable warranties or warranty disclaimers for TI products.

TI objects to and rejects any additional or different terms you may have proposed.

Mailing Address: Texas Instruments, Post Office Box 655303, Dallas, Texas 75265
Copyright © 2024, Texas Instruments Incorporated

Looking for pricing, stock, or lifecycle information?

Click below to explore more details on WIN SOURCE:

 [View SN75LVDS31PWRG4 on WIN SOURCE](#)

 [Texas Instruments](#) Information

Optimize Your Supply Chain with WIN SOURCE Solutions

-  Global Sourcing Solution
-  Obsolete Management
-  Cost Control Management
-  Shortage Management
-  Alternative Solution
-  Excess Inventory Management