



**THE DATASHEET OF
ISL84051IAZ-T**



ISL84051, ISL84052, ISL84053

Low Voltage, Single and Dual Supply, 8-to-1 Multiplexer, Dual 4-to-1 Multiplexer and a Triple SPDT Analog Switch

FN6047
Rev.10.00
May 16, 2011

The Intersil ISL84051, ISL84052, ISL84053 devices are precision, bidirectional, analog switches configured as a 8-Channel multiplexer/demultiplexer (ISL84051), a dual differential 4-Channel multiplexer/demultiplexer (ISL84052) and a triple single pole/double throw (SPDT) switch (ISL84053) designed to operate from a single +2V to +1.2V supply or from a ±2V to ±6V supply. All devices have an inhibit pin to simultaneously open all signal paths.

ON-resistance is 60Ω with a ±5V supply and 125Ω with a single +5V supply. Each switch can handle rail to rail analog signals. The off-leakage current is only 5nA at +85°C with a ±5V supply.

All digital inputs have 0.8V to 2.4V logic thresholds, ensuring TTL/CMOS logic compatibility when using a single +3.3V and +5V supply or dual ±5V supplies.

The ISL84051 is a 8-to-1 multiplexer device. The ISL84052 is a dual 4-to-1 multiplexer device. The ISL84053 is a committed triple SPDT, which is perfect for use in 2-to-1 multiplexer applications.

Table 1 summarizes the performance of this family.

TABLE 1. FEATURES AT A GLANCE

CONFIGURATION	ISL84051	ISL84052	ISL84053
	8:1 Mux	DUAL 4:1 Mux	TRIPLE SPDT
±5V r_{ON}	60Ω	60Ω	60Ω
±5V t_{ON}/t_{OFF}	50ns/40ns	50ns/40ns	50ns/40ns
5V r_{ON}	125Ω	125Ω	125Ω
5V t_{ON}/t_{OFF}	90ns/60ns	90ns/60ns	90ns/60ns
3V r_{ON}	250Ω	250Ω	250Ω
3V t_{ON}/t_{OFF}	180ns/100ns	180ns/100ns	180ns/100ns
Packages	16 Ld SOIC	16 Ld SOIC	16 Ld SOIC
	16 Ld QSOP	16 Ld QSOP	16 Ld QSOP
	16 Ld TSSOP	16 Ld TSSOP	16 Ld TSSOP

Related Literature

- Technical Brief [TB363](#) "Guidelines for Handling and Processing Moisture Sensitive Surface Mount Devices (SMDs)"
- Application Note [AN557](#) "Recommended Test Procedures for Analog Switches"

Features

- Drop-in Replacements for MAX4051/MAX4051A, MAX4052/MAX4052A and MAX4053/MAX4053A
- Pin Compatible with MAX4581, MAX4582, MAX4583 and with Industry Standard 74HC4051, 74HC4052 and 74HC4053
- ON-Resistance (r_{ON}) Max, $V_S = \pm 5V$ 100Ω
- ON-Resistance (r_{ON}) Max, $V_S = +5V$ 225Ω
- r_{ON} Matching Between Channels <6Ω
- Low Charge Injection 2pC
- Single Supply Operation +2V to +1.2V
- Dual Supply Operation ±2V to ±6
- Fast Switching Action ($V_S = +5V$)
 - t_{ON} 90ns
 - t_{OFF} 60ns
- Guaranteed Max Off-leakage @ $V_S = \pm 5V$ 5nA
- Break-Before-Make
- TTL, CMOS Compatible
- Pb-Free Available (RoHS Compliant)

Applications

- Portable Equipment
- Communications Systems
 - Radios
 - Telecom Infrastructure
 - ADSL, VDSL Modems
- Test Equipment
 - Medical Ultrasound
 - Magnetic Resonance Image
 - CT and PET Scanners (MRI)
 - ATE
 - Electrocardiograph
- Audio and Video Signal Routing
- Various Circuits
 - +3V/+5V DACs and ADCs
 - Sample and Hold Circuits
 - Operational Amplifier Gain Switching Networks
 - High Frequency Analog Switching
 - High Speed Multiplexing
 - Integrator Reset Circuits

Pin Configurations

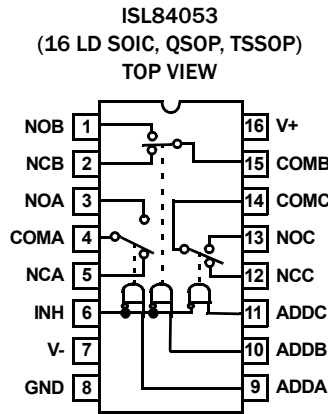
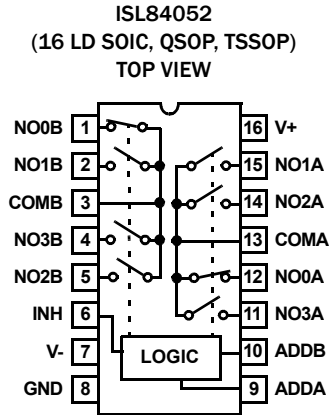
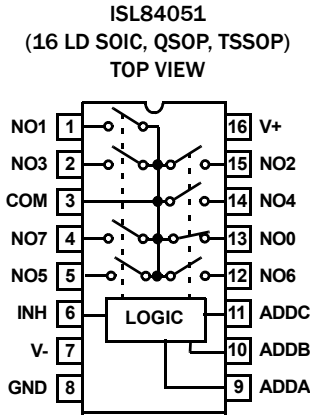

NOTE:

1. Switches Shown for Logic "0" Inputs.

Pin Description

PIN NAME	PIN NUMBER			FUNCTION
	ISL84051	ISL84052	ISL84053	
V+	16	16	16	Positive Power Supply Input
V-	7	7	7	Negative Power Supply Input. Connect to GND for Single Supply Configurations.
GND	8	8	8	Ground Connection
INH	6	6	6	Digital Control Input. Connect to GND for Normal Operation. Connect to V+ to turn all switches off.
COM	3	-	-	Analog Switch Common Pin
COMA	-	13	4	
COMB	-	3	15	
COMC	-	-	14	
NO1, NO3, NO7, NO5, NO6, NO4, NO2	1, 2, 4, 5, 12, 14, 15	-	-	Analog Switch Normally Open Pin

Pin Description (Continued)

PIN NAME	PIN NUMBER			FUNCTION
	ISL84051	ISL84052	ISL84053	
NO0B, NO1B, NO3B, NO2B, NO3A, NO0A, NO2A, NO1A	-	1, 2, 4, 5, 11, 12, 14, 15	-	Analog Switch Normally Open Pin
NOB, NOA, NOC	-	-	1, 3, 13	
NCB, NCA, NCC	-	-	2, 5, 12	Analog Switch Normally Closed Pin
ADDA, ADDB, ADDC	9, 10 11	9, 10 -	9, 10 11	Address Input Pin

Ordering Information

PART NUMBER	PART MARKING	TEMP. RANGE (°C)	PACKAGE (Pb-free)	PKG. DWG. #
ISL84051IAZ	84051 IAZ	-40 to +85	16 Ld QSOP	M16.15A
ISL84051IBZ	84051IBZ	-40 to +85	16 Ld SOIC	M16.15
ISL84051IVZ	84051 IVZ	-40 to +85	16 Ld TSSOP	M16.173
ISL84052IAZ	84052 IAZ	-40 to +85	16 Ld QSOP	M16.15A
ISL84052IBZ	84052IBZ	-40 to +85	16 Ld SOIC	M16.15
ISL84052IVZ	84052 IVZ	-40 to +85	16 Ld TSSOP	M16.173
ISL84053IAZ	84053 IAZ	-40 to +85	16 Ld QSOP	M16.15A
ISL84053IBZ	84053IBZ	-40 to +85	16 Ld SOIC	M16.15
ISL84053IVZ	84053 IVZ	-40 to +85	16 Ld TSSOP	M16.173

NOTES:

- Add "-T*" suffix for tape and reel. Please refer to [TB347](#) for details on reel specifications.
- These Intersil Pb-free plastic packaged products employ special Pb-free material sets, molding compounds/die attach materials, and 100% matte tin plate plus anneal (e3 termination finish, which is RoHS compliant and compatible with both SnPb and Pb-free soldering operations). Intersil Pb-free products are MSL classified at Pb-free peak reflow temperatures that meet or exceed the Pb-free requirements of IPC/JEDEC J STD-020
- For Moisture Sensitivity Level (MSL), please see device information page for [ISL84051](#), [ISL84052](#), [ISL84053](#). For more information on MSL please see techbrief [TB363](#).

Truth Tables

ISL84051

INH	ADDC	ADDB	ADDA	SWITCH ON
1	X	X	X	None
0	0	0	0	NO0
0	0	0	1	NO1
0	0	1	0	NO2
0	0	1	1	NO3
0	1	0	0	NO4
0	1	0	1	NO5
0	1	1	0	NO6
0	1	1	1	NO7

ISL84052

INH	ADDB	ADDA	SWITCH ON
1	X	X	None
0	0	0	NO0
0	0	1	NO1
0	1	0	NO2
0	1	1	NO3

ISL84053

INH	ADD _C	ADD _B	ADD _A	SWITCH ON
1	X	X	X	None
0	X	X	0	NC _A
0	X	X	1	NO _A
0	X	0	X	NC _B
0	X	1	X	NO _B
0	0	X	X	NC _C
0	1	X	X	NO _C

NOTE: Logic "0" ≤ 0.8V. Logic "1" ≥ 2.4V, with V+ between 2.7V and 10V. X = Don't Care.

Absolute Maximum Ratings

V+ to V-	-0.3V to 15V
V+ to GND	-0.3V to 15V
V- to GND	-15V to 0.3V
Input Voltages	
INH, NO, NC, ADD (Note 5)	((V-) - 0.3) to ((V+) + 0.3V)
Output Voltages	
COM (Note 5)	((V-) - 0.3) to ((V+) + 0.3V)
Continuous Current (Any Terminal)	±30mA
Peak Current NO, NC, or COM	
(Pulsed 1ms, 10% Duty Cycle, Max)	±100mA
ESD Rating	
Human Body Model (Per MIL-STD-883, Method 3015.7)	>2kV

Thermal Information

Thermal Resistance (Typical, Notes 6, 7)	θ_{JA} (°C/W)	θ_{JC} (°C/W)
16 Ld SOIC Package	75	39
16 Ld QSOP Package	95	56
16 Ld TSSOP Package	110	33
Maximum Junction Temperature (Plastic Package)	+150°C	
Maximum Storage Temperature Range	-65°C to +150°C	
Pb-Free Reflow Profile	see link below	
	http://www.intersil.com/pbfree/Pb-FreeReflow.asp	

Operating Conditions

Temperature Range	-40°C to +85°C
-------------------------	----------------

CAUTION: Do not operate at or near the maximum ratings listed for extended periods of time. Exposure to such conditions may adversely impact product reliability and result in failures not covered by warranty.

NOTES:

- Signals on NC, NO, COM, ADD, or INH exceeding V+ or V- are clamped by internal diodes. Limit forward diode current to maximum current ratings.
- θ_{JA} is measured with the component mounted on a high effective thermal conductivity test board in free air. See Tech Brief TB379 for details.
- For θ_{JC} , the "case temp" location is taken at the package top center.

Electrical Specifications 5V Supply Test Conditions: $V_{SUPPLY} = \pm 4.5V$ to $\pm 5.5V$, $V_{GND} = 0V$, $V_{INH} = 2.4V$, $V_{INL} = 0.8V$ (Note 8), Unless Otherwise Specified. **Boldface limits apply over the operating temperature range, -40°C to +85°C.**

PARAMETER	TEST CONDITIONS	TEMP (°C)	MIN (Notes 9, 10)	TYP	MAX (Notes 9, 10)	UNITS
ANALOG SWITCH CHARACTERISTICS						
Analog Signal Range, V_{ANALOG}		Full	V-	-	V+	V
ON-Resistance, r_{ON}	$V_S = \pm 5V$, $I_{COM} = 1mA$, V_{NO} or $V_{NC} = \pm 3V$ (see Figure 5)	+25	-	60	100	Ω
		Full	-	-	125	Ω
r_{ON} Matching Between Channels, Δr_{ON}	$V_S = \pm 5V$, $I_{COM} = 1mA$, V_{NO} or $V_{NC} = \pm 3V$ (Note 11)	+25	-	-	6	Ω
		Full	-	-	12	Ω
r_{ON} Flatness, $r_{FLAT(ON)}$	$V_S = \pm 5V$, $I_{COM} = 1mA$, V_{NO} or $V_{NC} = \pm 3V$, 0V (Note 12)	+25	-	-	10	Ω
		Full	-	-	15	Ω
NO or NC OFF Leakage Current, $I_{NO(OFF)}$ or $I_{NC(OFF)}$	$V_S = \pm 5.5V$, $V_{COM} = \pm 4.5V$, V_{NO} or $V_{NC} = \pm 4.5V$ (Note 12)	+25	-	0.002	-	nA
		Full	-5	-	5	nA
COM OFF Leakage Current, $I_{COM(OFF)}$, (ISL84051)	$V_S = \pm 5.5V$, $V_{COM} = \pm 4.5V$, V_{NO} or $V_{NC} = \pm 4.5V$ (Note 12)	+25	-	0.002	-	nA
		Full	-5	-	5	nA
COM OFF Leakage Current, $I_{COM(OFF)}$, (ISL84052, ISL84053)	$V_S = \pm 5.5V$, $V_{COM} = \pm 4.5V$, V_{NO} or $V_{NC} = \pm 4.5V$ (Note 12)	+25	-	0.002	-	nA
		Full	-2.5	-	2.5	nA
COM ON Leakage Current, $I_{COM(ON)}$, (ISL84051)	$V_S = \pm 5.5V$, $V_{COM} = V_{NO}$ or $V_{NC} = \pm 4.5V$ (Note 12)	+25	-	0.002	-	nA
		Full	-5	-	5	nA
COM ON Leakage Current, $I_{COM(ON)}$, (ISL84052, ISL84053)	$V_S = \pm 5.5V$, $V_{COM} = V_{NO}$ or $V_{NC} = \pm 4.5V$ (Note 12)	+25	-	0.002	-	nA
		Full	-2.5	-	2.5	nA
DIGITAL INPUT CHARACTERISTICS						
Input Voltage High, V_{INH} , V_{ADDH}		Full	2.4	-	-	V
Input Voltage Low, V_{INL} , V_{ADDL}		Full	-	-	0.8	V
Input Current, I_{INH} , I_{INL} , I_{ADDH} , I_{ADDL}	$V_S = \pm 5.5V$, V_{INH} , $V_{ADD} = 0V$ or $V+$	Full	-1	0.03	1	μA

Electrical Specifications 5V Supply Test Conditions: $V_{SUPPLY} = \pm 4.5V$ to $\pm 5.5V$, $GND = 0V$, $V_{INH} = 2.4V$, $V_{INL} = 0.8V$ (Note 8), Unless Otherwise Specified. **Boldface limits apply over the operating temperature range, $-40^{\circ}C$ to $+85^{\circ}C$.** (Continued)

PARAMETER	TEST CONDITIONS	TEMP (°C)	MIN (Notes 9, 10)	TYP	MAX (Notes 9, 10)	UNITS	
DYNAMIC CHARACTERISTICS							
Inhibit Turn-ON Time, t_{ON}	$V_S = \pm 4.5V$, V_{NO} or $V_{NC} = \pm 3V$, $R_L = 300\Omega$, $C_L = 35pF$, $V_{IN} = 0V$ to $3V$ (see Figure 1)	+25	-	50	-	ns	
		Full	-	60	-	ns	
Inhibit Turn-OFF Time, t_{OFF}	$V_S = \pm 4.5V$, V_{NO} or $V_{NC} = \pm 3V$, $R_L = 300\Omega$, $C_L = 35pF$, $V_{IN} = 0V$ to $3V$ (see Figure 1)	+25	-	40	-	ns	
		Full	-	50	-	ns	
Address Transition Time, t_{TRANS}	$V_S = \pm 4.5V$, V_{NO} or $V_{NC} = \pm 3V$, $R_L = 300\Omega$, $C_L = 35pF$, $V_{IN} = 0V$ to $3V$ (see Figure 1)	+25	-	75	-	ns	
Break-Before-Make Time, t_{BBM}	$V_S = \pm 5.5V$, V_{NO} or $V_{NC} = 3V$, $R_L = 300\Omega$, $C_L = 35pF$, $V_{IN} = 0V$ to $3V$ (see Figure 3)	+25	-	10	-	ns	
Charge Injection, Q	$C_L = 1.0nF$, $V_G = 0V$, $R_G = 0\Omega$ (see Figure 2)	+25	-	2	-	pC	
NO/NC OFF-Capacitance, C_{OFF}	$f = 1MHz$, V_{NO} or $V_{NC} = V_{COM} = 0V$ (see Figure 7)	+25	-	3	-	pF	
COM OFF-Capacitance, C_{OFF}	$f = 1MHz$, V_{NO} or $V_{NC} = V_{COM} = 0V$ (see Figure 7)	ISL84051	+25	-	21	-	pF
		ISL84052	+25	-	12	-	pF
		ISL84053	+25	-	9	-	pF
COM ON-Capacitance, $C_{COM(ON)}$	$f = 1MHz$, V_{NO} or $V_{NC} = V_{COM} = 0V$ (see Figure 7)	ISL84051	+25	-	26	-	pF
		ISL84052	+25	-	18	-	pF
		ISL84053	+25	-	14	-	pF
OFF Isolation	$R_L = 50\Omega$, $C_L = 15pF$, $f = 100kHz$ V_{NO} or $V_{NC} = 1V_{RMS}$ (see Figures 4 and 6)	+25	-	<90	-	dB	
Crosstalk, (Note 9) (ISL84052, ISL84053 Only)		+25	-	< -90	-	dB	
POWER SUPPLY CHARACTERISTICS							
Power Supply Range		Full	± 2	-	± 6	V	
Positive Supply Current, I_+	$V_S = \pm 5.5V$, V_{INH} , $V_{ADD} = 0V$ or V_+ , Switch On or Off	+25	-1	0.1	1	μA	
		Full	-10	-	10	μA	
Negative Supply Current, I_-		25	-1	0.1	1	μA	
		Full	-10	-	10	μA	

Electrical Specifications 5V Supply Test Conditions: $V_+ = +4.5V$ to $+5.5V$, $V_- = GND = 0V$, $V_{INH} = 2.4V$, $V_{INL} = 0.8V$ (Note 8), Unless Otherwise Specified. **Boldface limits apply over the operating temperature range, $-40^{\circ}C$ to $+85^{\circ}C$.**

PARAMETER	TEST CONDITIONS	TEMP (°C)	MIN (Notes 9, 10)	TYP	MAX (Notes 9, 10)	UNITS
ANALOG SWITCH CHARACTERISTICS						
Analog Signal Range, V_{ANALOG}		Full	0	-	V+	V
ON-Resistance, r_{ON}	$V_+ = 5V$, $I_{COM} = 1.0mA$, V_{NO} or $V_{NC} = 3.5V$ (see Figure 5)	+25	-	125	225	Ω
		Full	-	-	280	Ω
NO or NC OFF Leakage Current, $I_{NO(OFF)}$ or $I_{NC(OFF)}$	$V_+ = 5.5V$, $V_{COM} = 0V$, $4.5V$, V_{NO} or $V_{NC} = 4.5V$, $0V$ (Note 12)	+25	-	0.002	-	nA
		Full	-10	-	10	nA
COM OFF Leakage Current, $I_{COM(OFF)}$, (ISL84051)	$V_+ = 5.5V$, $V_{COM} = 0V$, $4.5V$, V_{NO} or $V_{NC} = 4.5V$, $0V$ (Note 12)	+25	-	0.002	-	nA
		Full	-10	-	10	nA
COM OFF Leakage Current, $I_{COM(OFF)}$, (ISL84052, ISL84053)	$V_+ = 5.5V$, $V_{COM} = 0V$, $4.5V$, V_{NO} or $V_{NC} = 4.5V$, $0V$ (Note 12)	+25	-	0.002	-	nA
		Full	-5	-	5	nA

Electrical Specifications 5V Supply Test Conditions: $V_+ = +4.5V$ to $+5.5V$, $V_- = GND = 0V$, $V_{INH} = 2.4V$, $V_{INL} = 0.8V$
 (Note 8), Unless Otherwise Specified. **Boldface limits apply over the operating temperature range, $-40^\circ C$ to $+85^\circ C$.** (Continued)

PARAMETER	TEST CONDITIONS	TEMP ($^\circ C$)	MIN (Notes 9, 10)	TYP	MAX (Notes 9, 10)	UNITS
COM ON Leakage Current, $I_{COM(ON)}$	$V_+ = 5.5V$, $V_{COM} = V_{NO}$ or $V_{NC} = 4.5V$ (Note 12)	+25	-	0.002	-	nA
		Full	-10	-	10	nA
DIGITAL INPUT CHARACTERISTICS						
Input Voltage High, V_{INH} , V_{ADDH}		Full	2.4	-	-	V
Input Voltage Low, V_{INL} , V_{ADDL}		Full	-	-	0.8	V
Input Current, I_{INH} , I_{INL} , I_{ADDH} , I_{ADDL}	$V_+ = 5.5V$, V_{INH} , $V_{ADD} = 0V$ or V_+	Full	-1	0.03	1	μA
DYNAMIC CHARACTERISTICS						
Inhibit Turn-ON Time, t_{ON}	$V_+ = 4.5V$, V_{NO} or $V_{NC} = 3V$, $R_L = 300\Omega$, $C_L = 35pF$, $V_{IN} = 0$ to $3V$ (see Figure 1)	+25	-	90	-	ns
		Full	-	100	-	ns
Inhibit Turn-OFF Time, t_{OFF}	$V_+ = 4.5V$, V_{NO} or $V_{NC} = 3V$, $R_L = 300\Omega$, $C_L = 35pF$, $V_{IN} = 0V$ to $3V$ (see Figure 1)	+25	-	60	-	ns
		Full	-	70	-	ns
Break-Before-Make Time, t_{BBM}	$V_+ = 5.5V$, V_{NO} or $V_{NC} = 3V$, $R_L = 300\Omega$, $C_L = 35pF$, $V_{IN} = 0V$ to $3V$ (see Figure 3)	+25	-	30	-	ns
Charge Injection, Q	$C_L = 1.0nF$, $V_G = 0V$, $R_G = 0\Omega$ (see Figure 2)	+25	-	2	-	pC
OFF Isolation	$R_L = 50\Omega$, $C_L = 15pF$, $f = 100kHz$, V_{NO} or $V_{NC} = 1V_{RMS}$ (see Figures 4 and 6)	+25	-	<90	-	dB
Crosstalk, (Note 9) (ISL84052, ISL840533 Only)		+25	-	<-90	-	dB
POWER SUPPLY CHARACTERISTICS						
Power Supply Range		Full	2	-	12	V
Positive Supply Current, I_+	$V_+ = 5.5V$, $V_- = 0V$, V_{INH} , $V_{ADD} = 0V$ or V_+ , Switch On or Off	+25	-1	-	1	μA
		Full	-10	-	10	μA

Electrical Specifications 3.3V Supply Test Conditions: $V_+ = +3.0V$ to $+3.6V$, $V_- = GND = 0V$, $V_{INH} = 2.4V$, $V_{INL} = 0.8V$
 (Note 8), Unless Otherwise Specified. **Boldface limits apply over the operating temperature range, $-40^\circ C$ to $+85^\circ C$.**

PARAMETER	TEST CONDITIONS	TEMP ($^\circ C$)	MIN (Notes 9, 10)	TYP	MAX (Notes 9, 10)	UNITS
ANALOG SWITCH CHARACTERISTICS						
Analog Signal Range, V_{ANALOG}		Full	0	-	V+	V
ON-Resistance, r_{ON}	$V_+ = 3V$, $I_{COM} = 1.0mA$, V_{NO} or $V_{NC} = 1.5V$	+25	-	250	-	Ω
		Full	-	270	-	Ω
NO or NC OFF Leakage Current, $I_{NO(OFF)}$ or $I_{NC(OFF)}$	$V_+ = 3.6V$, $V_{COM} = 0V$, $3V$, V_{NO} or $V_{NC} = 3V$, $0V$ (Note 12)	+25	-	0.002	-	nA
		Full	-10	-	10	nA
COM OFF Leakage Current, $I_{COM(OFF)}$, (ISL84051)	$V_+ = 3.6V$, $V_{COM} = 0V$, $3V$, V_{NO} or $V_{NC} = 3V$, $0V$ (Note 12)	+25	-	0.002	-	nA
		Full	-10	-	10	nA
COM OFF Leakage Current, $I_{COM(OFF)}$, (ISL84052, ISL84053)	$V_+ = 3.6V$, $V_{COM} = 0V$, $3V$, V_{NO} or $V_{NC} = 3V$, $0V$ (Note 12)	+25	-	0.002	-	nA
		Full	-5	-	5	nA
COM ON Leakage Current, $I_{COM(ON)}$	$V_+ = 3.6V$, $V_{COM} = V_{NO}$ or $V_{NC} = 3V$ (Note 12)	+25	-	0.002	-	nA
		Full	-10	-	10	nA
DIGITAL INPUT CHARACTERISTICS						
Input Voltage High, V_{INH} , V_{ADDH}		Full	2.4	-	-	V

Electrical Specifications 3.3V Supply Test Conditions: $V+ = +3.0V$ to $+3.6V$, $V- = GND = 0V$, $V_{INH} = 2.4V$, $V_{INL} = 0.8V$ (Note 8), Unless Otherwise Specified. **Boldface limits apply over the operating temperature range, $-40^{\circ}C$ to $+85^{\circ}C$.** (Continued)

PARAMETER	TEST CONDITIONS	TEMP (°C)	MIN (Notes 9, 10)	TYP	MAX (Notes 9, 10)	UNITS
Input Voltage Low, V_{INL} , V_{ADDL}		Full	-	-	0.8	V
Input Current, I_{INH} , I_{INL} , I_{ADDH} , I_{ADDL}	$V+ = 3.6V$, V_{INH} , $V_{ADD} = 0V$ or $V+$	Full	-1	0.03	1	μA
DYNAMIC CHARACTERISTICS						
Inhibit Turn-ON Time, t_{ON}	$V+ = 3V$, V_{NO} or $V_{NC} = 1.5V$, $R_L = 300\Omega$, $C_L = 35pF$, $V_{IN} = 0V$ to $3V$ (see Figure 1)	+25	-	180	-	ns
		Full	-	280	-	ns
Inhibit Turn-OFF Time, t_{OFF}	$V+ = 3V$, V_{NO} or $V_{NC} = 1.5V$, $R_L = 300\Omega$, $C_L = 35pF$, $V_{IN} = 0V$ to $3V$ (see Figure 1)	+25	-	100	-	ns
		Full	-	200	-	ns
Break-Before-Make Time, t_{BBM}	$V+ = 3.6V$, V_{NO} or $V_{NC} = 1.5V$, $R_L = 300\Omega$, $C_L = 35pF$, $V_{IN} = 0V$ to $3V$ (see Figure 3)	+25	-	90	-	ns
Charge Injection, Q	$C_L = 1.0nF$, $V_G = 0V$, $R_G = 0\Omega$ (see Figure 2)	+25	-	1	-	pC
OFF Isolation	$R_L = 50\Omega$, $C_L = 15pF$, $f = 100kHz$ V_{NO} or $V_{NC} = 1V_{RMS}$, (see Figures 4 and 6)	+25	-	<90	-	dB
Crosstalk, (Note 9) (ISL84052, ISL84053 Only)		+25	-	<-90	-	dB
POWER SUPPLY CHARACTERISTICS						
Power Supply Range		Full	2	-	12	V
Positive Supply Current, $I+$	$V+ = 3.6V$, $V- = 0V$, V_{INH} , $V_{ADD} = 0V$ or $V+$ Switch On or Off	+25	-1	-	1	μA
		Full	-10	-	10	μA

NOTES:

8. V_{IN} = Input voltage to perform proper function.
9. The algebraic convention, whereby the most negative value is a minimum and the most positive a maximum, is used in this data sheet.
10. Compliance to datasheet limits is assured by one or more methods: production test, characterization and/or design.
11. $\Delta r_{ON} = r_{ON} (MAX) - r_{ON} (MIN)$.
12. Flatness is defined as the difference between maximum and minimum value of on-resistance over the specified analog signal range.
13. Between any two switches.

Test Circuits and Waveforms

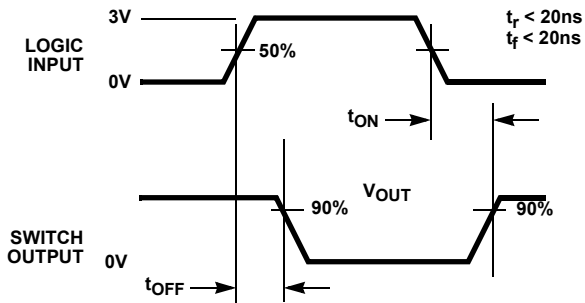

Logic input waveform is inverted for switches that have the opposite logic sense.

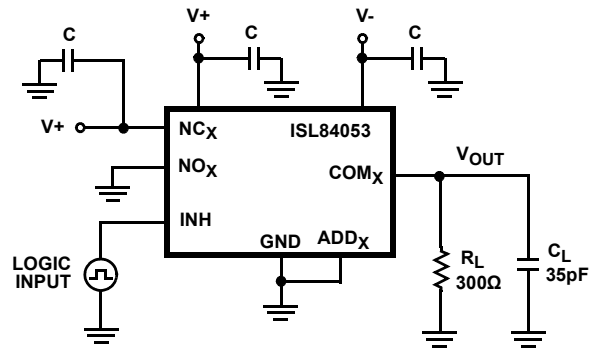
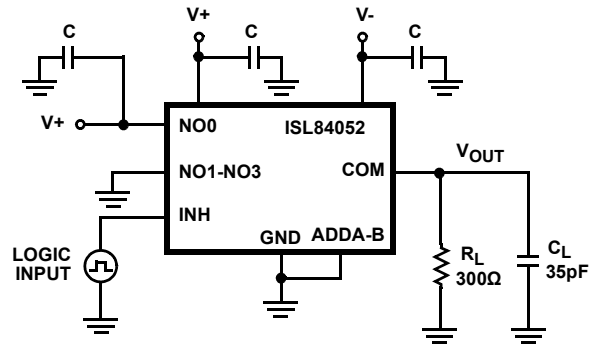
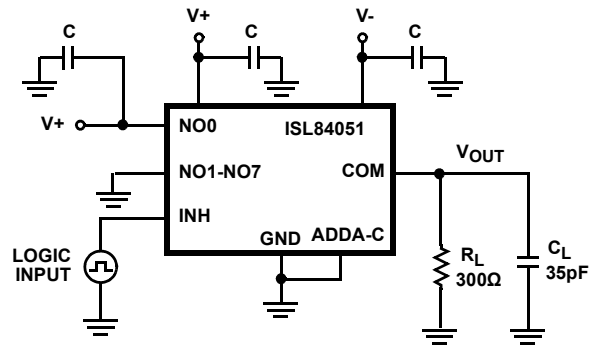

Repeat test for other switches. C_L includes fixture and stray capacitance.

$$V_{OUT} = V_{(NO \text{ or } NC)} \frac{R_L}{R_L + r_{ON}}$$

FIGURE 1A. INHIBIT t_{ON}/t_{OFF} MEASUREMENT POINTS

FIGURE 1B. INHIBIT t_{ON}/t_{OFF} TEST CIRCUIT

FIGURE 1. SWITCHING TIMES

Test Circuits and Waveforms (Continued)

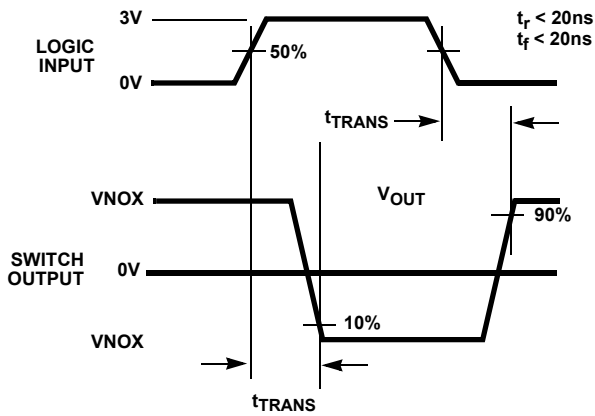

Logic input waveform is inverted for switches that have the opposite logic sense.

FIGURE 1C. ADDRESS t_{TRANS} MEASUREMENT POINTS

FIGURE 1. SWITCHING TIMES (Continued)

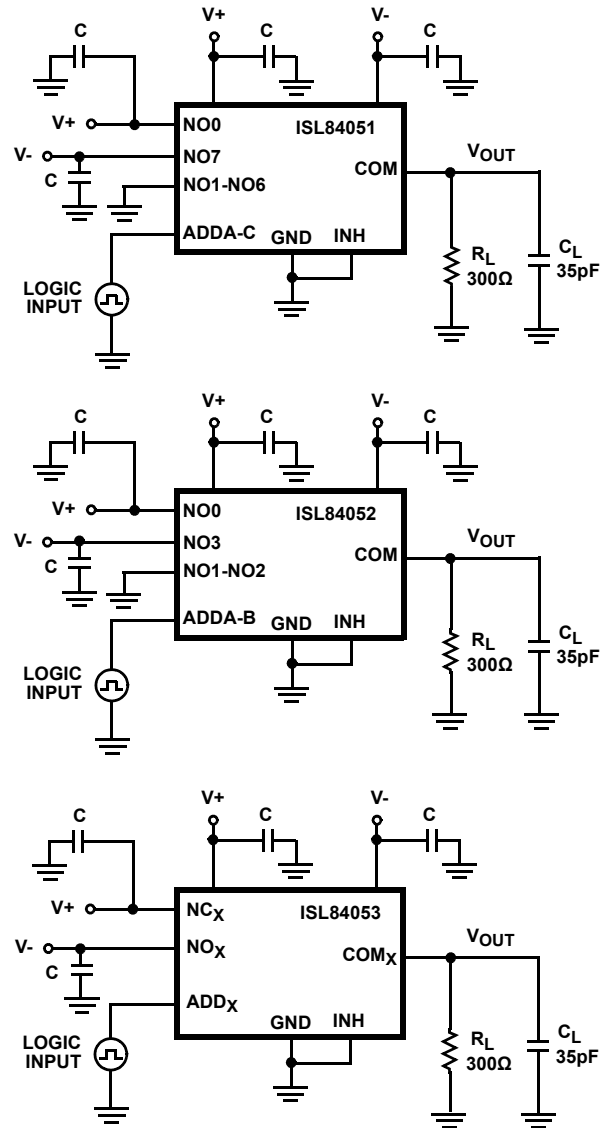

Repeat test for other switches. C_L includes fixture and stray capacitance.

$$V_{OUT} = V_{(NO \text{ or } NC)} \frac{R_L}{R_L + r_{ON}}$$

FIGURE 1D. ADDRESS t_{TRANS} TEST CIRCUIT

Test Circuits and Waveforms (Continued)

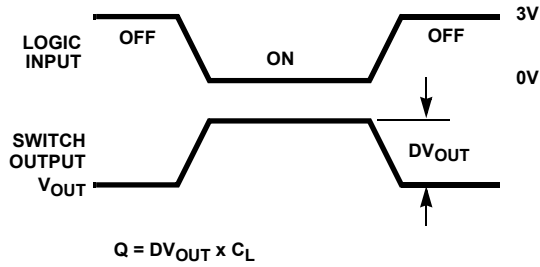

FIGURE 2A. Q MEASUREMENT POINTS

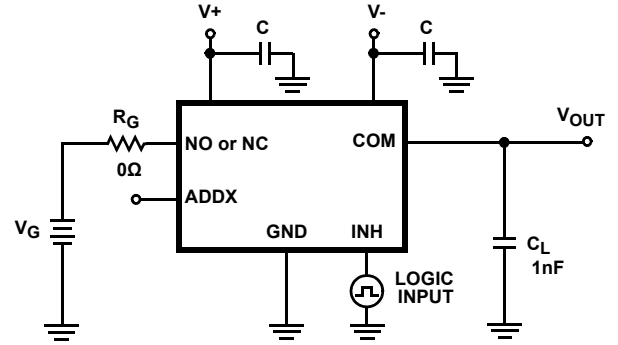

FIGURE 2B. Q TEST CIRCUIT

FIGURE 2. CHARGE INJECTION

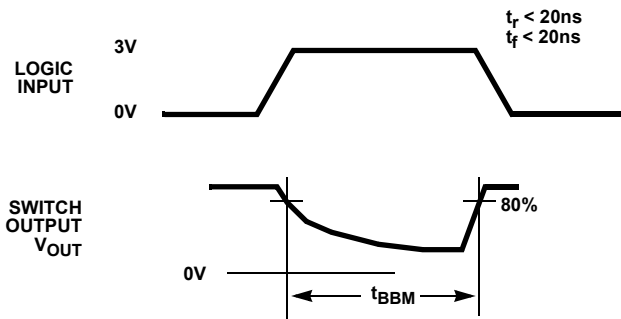
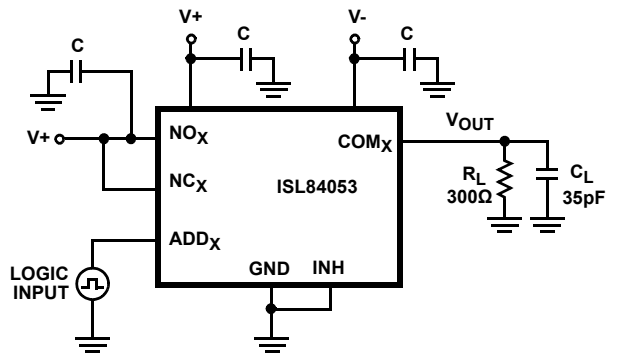
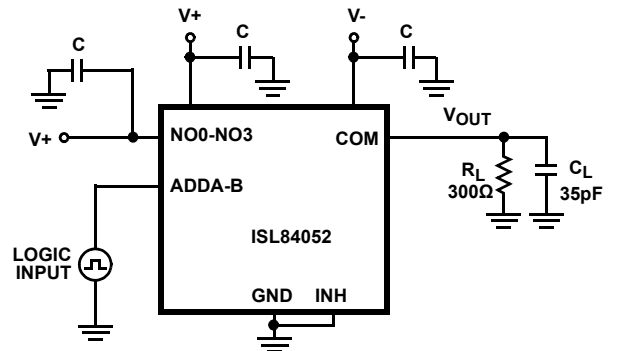
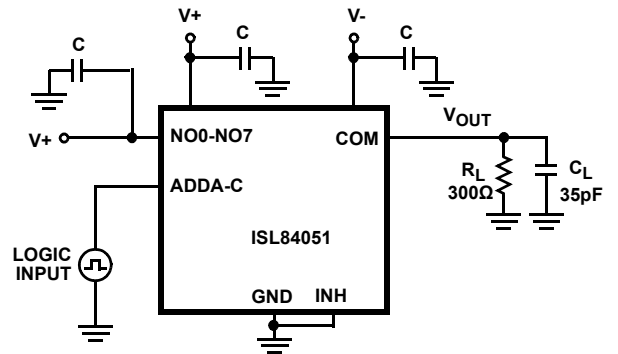

FIGURE 3A. t_{BBM} MEASUREMENT POINTS



Repeat test for other switches. C_L includes fixture and stray capacitance.

FIGURE 3B. t_{BBM} TEST CIRCUIT

FIGURE 3. BREAK-BEFORE-MAKE TIME

Test Circuits and Waveforms (Continued)

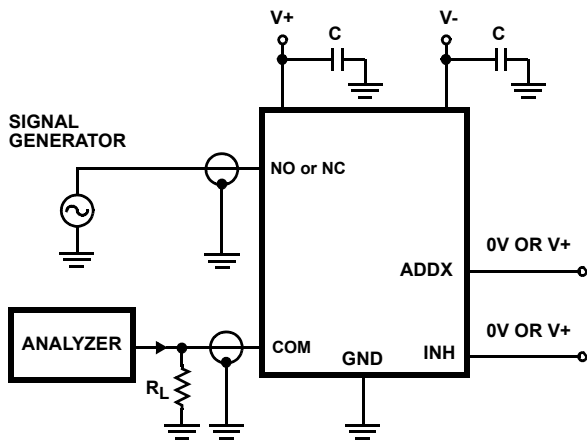

FIGURE 4. OFF ISOLATION TEST CIRCUIT

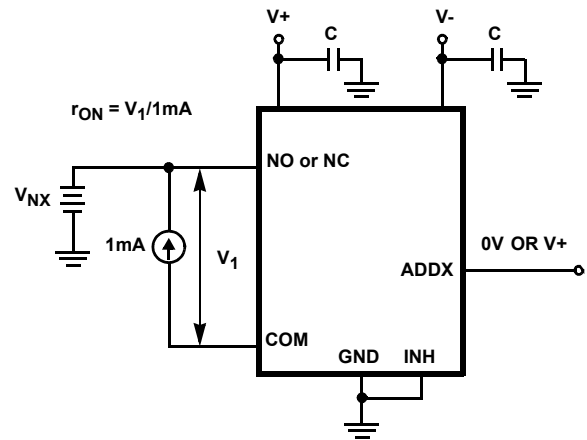

FIGURE 5. r_{ON} TEST CIRCUIT

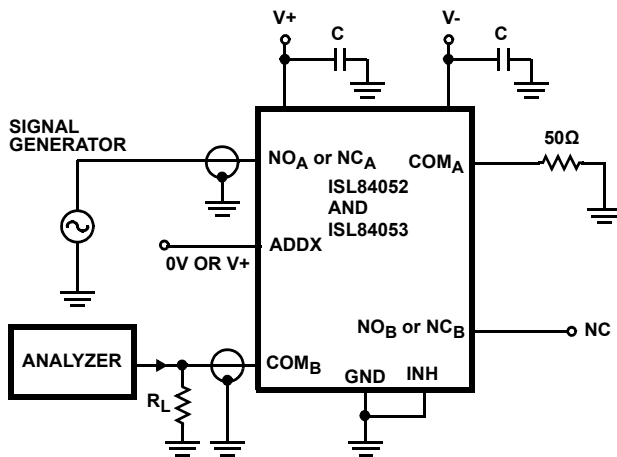

FIGURE 6. CROSSTALK TEST CIRCUIT

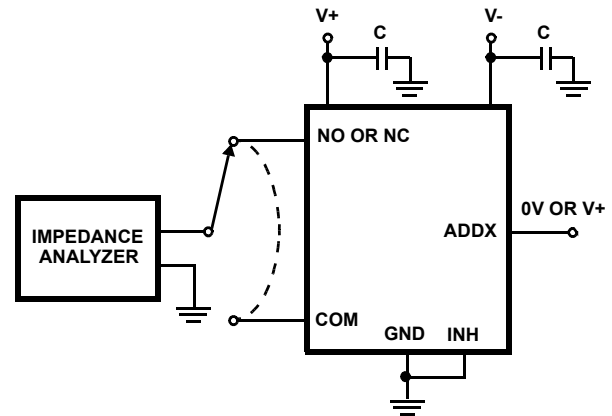

FIGURE 7. CAPACITANCE TEST CIRCUIT

Detailed Description

The ISL84051, ISL84052, ISL84053 analog switches offer precise switching capability from a bipolar $\pm 2V$ to $\pm 6V$ or a single 2V to 12V supply with low on-resistance (60Ω) and high speed operation ($t_{ON} = 50ns$, $t_{OFF} = 40ns$). The devices are especially well suited to portable battery powered equipment thanks to the low operating supply voltage (2V), low power consumption ($3\mu W$), low leakage currents (5nA max). High frequency applications also benefit from the wide bandwidth, and the very high off isolation and crosstalk rejection.

Supply Sequencing And Overvoltage Protection

With any CMOS device, proper power supply sequencing is required to protect the device from excessive input currents

which might permanently damage the IC. All I/O pins contain ESD protection diodes from the pin to V+ and to V- (see Figure 8). To prevent forward biasing these diodes, V+ and V- must be applied before any input signals, and input signal voltages must remain between V+ and V-. If these conditions cannot be guaranteed, then one of the following two protection methods should be employed.

Logic inputs can easily be protected by adding a $1k\Omega$ resistor in series with the input (see Figure 8). The resistor limits the input current below the threshold that produces permanent damage, and the sub-microamp input current produces an insignificant voltage drop during normal operation.

This method is not applicable for the signal path inputs. Adding a series resistor to the switch input defeats the purpose of using a low r_{ON} switch, so two small signal diodes can be

added in series with the supply pins to provide overvoltage protection for all pins (see Figure 8). These additional diodes limit the analog signal from 1V below $V+$ to 1V above $V-$. The low leakage current performance is unaffected by this approach, but the switch resistance may increase, especially at low supply voltages.

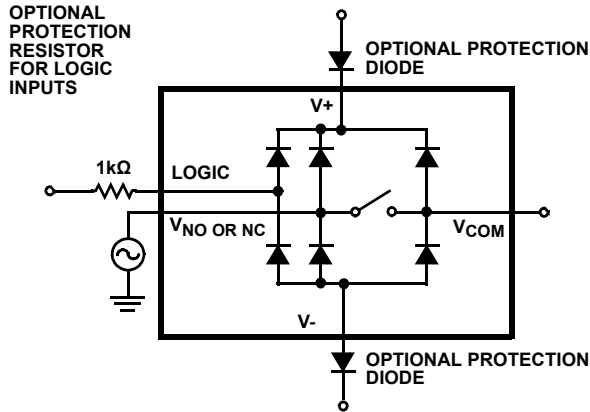

FIGURE 8. INPUT OVERVOLTAGE PROTECTION

Power-Supply Considerations

The ISL8405x construction is typical of most CMOS analog switches, in that they have three supply pins: $V+$, $V-$, and GND. $V+$ and $V-$ drive the internal CMOS switches and set their analog voltage limits, so there are no connections between the analog signal path and GND. Unlike switches with a 13V maximum supply voltage, the ISL8405x 1.5V maximum supply voltage provides plenty of room for the 10% tolerance of 12V supplies ($\pm 6V$ or 12V single supply), as well as room for overshoot and noise spikes.

This family of switches performs equally well when operated with bipolar or single voltage supplies. The minimum recommended supply voltage is 2V or $\pm 2V$. It is important to note that the input signal range, switching times, and ON-resistance degrade at lower supply voltages. Refer to the “Electrical Specification” tables beginning on page 5 and “Typical Performance Curves” beginning on page 14 for details.

$V+$ and GND power the internal logic (thus setting the digital switching point) and level shifters. The level shifters convert the logic levels to switched $V+$ and $V-$ signals to drive the analog switch gate terminals.

Logic-Level Thresholds

$V+$ and GND power the internal logic stages, so $V-$ has no effect on logic thresholds. This switch family is TTL compatible (0.8V and 2.4V) over a $V+$ supply range of 2.7V to 10V. At 12V the V_{IH} level is about 3.5V. This is still below the CMOS guaranteed high output minimum level of 4V, but noise margin is reduced. For best results with a 12V supply, use a logic family that provides a V_{OH} greater than 4V.

The digital input stages draw supply current whenever the digital input voltage is not at one of the supply rails. Driving the digital input signals from GND to $V+$ with a fast transition time minimizes power dissipation.

High-Frequency Performance

In 50 Ω systems, signal response is reasonably flat even past 100MHz (see Figure 17). Figure 17 also illustrates that the frequency response is very consistent over varying analog signal levels.

An OFF switch acts like a capacitor and passes higher frequencies with less attenuation, resulting in signal feed through from a switch’s input to its output. Off isolation is the resistance to this feed through, while crosstalk indicates the amount of feed through from one switch to another. Figure 18 details the high off isolation and crosstalk rejection provided by this family. At 10MHz, off isolation is about 55dB in 50 Ω systems, decreasing approximately 20dB per decade as frequency increases. Higher load impedances decrease off isolation and crosstalk rejection due to the voltage divider action of the switch OFF impedance and the load impedance.

Leakage Considerations

Reverse ESD protection diodes are internally connected between each analog-signal pin and both $V+$ and $V-$. One of these diodes conducts if any analog signal exceeds $V+$ or $V-$.

Virtually all the analog leakage current comes from the ESD diodes to $V+$ or $V-$. Although the ESD diodes on a given signal pin are identical and therefore fairly well balanced, they are reverse biased differently. Each is biased by either $V+$ or $V-$ and the analog signal. This means their leakages will vary as the signal varies. The difference in the two diode leakages to the $V+$ and $V-$ pins constitutes the analog-signal-path leakage current. All analog leakage current flows between each pin and one of the supply terminals, not to the other switch terminal. This is why both sides of a given switch can show leakage currents of the same or opposite polarity. There is no connection between the analog signal paths and GND.

Typical Performance Curves $T_A = +25^\circ\text{C}$, Unless Otherwise Specified

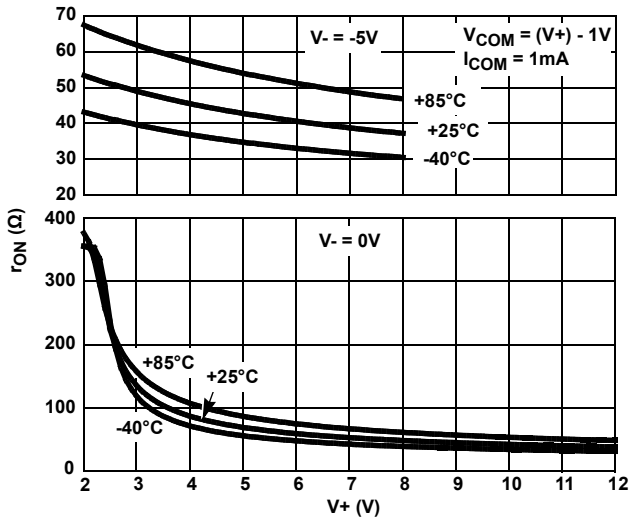

FIGURE 9. ON-RESISTANCE vs SUPPLY VOLTAGE

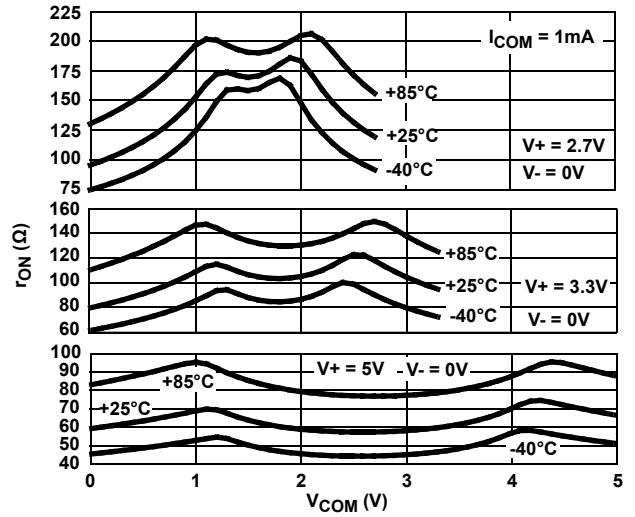

FIGURE 10. ON-RESISTANCE vs SWITCH VOLTAGE

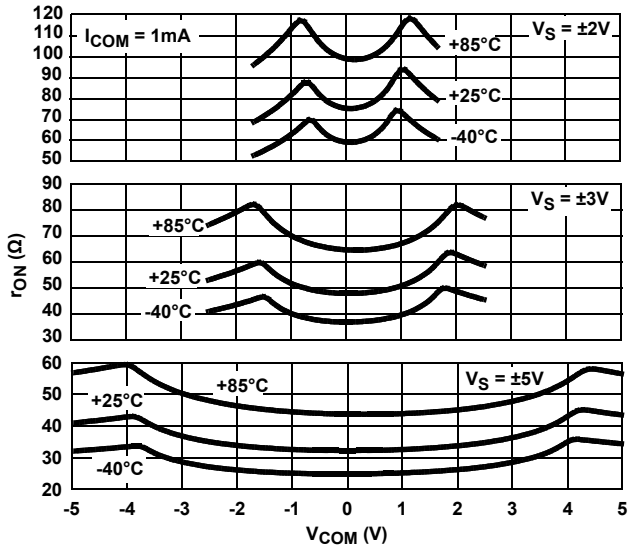

FIGURE 11. ON-RESISTANCE vs SWITCH VOLTAGE

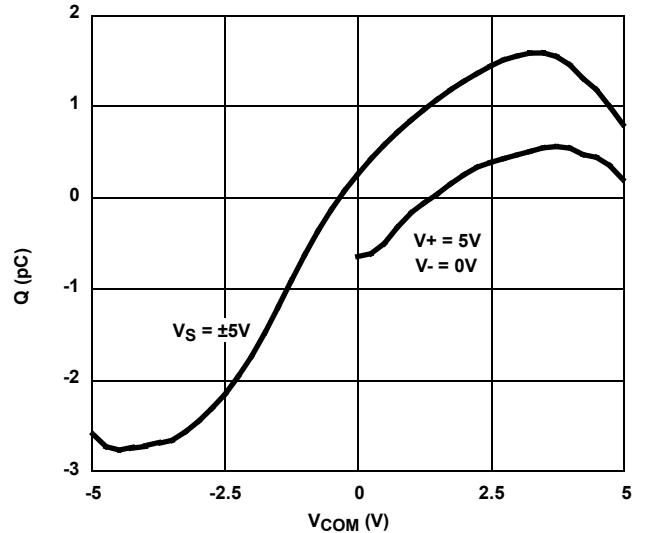

FIGURE 12. CHARGE INJECTION vs SWITCH VOLTAGE

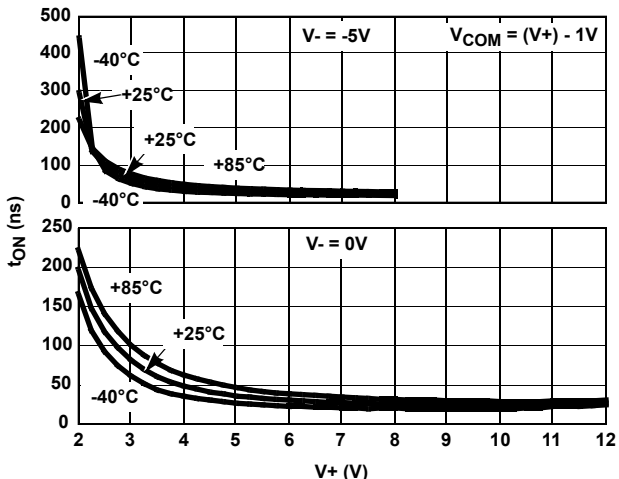

FIGURE 13. INHIBIT TURN-ON TIME vs SUPPLY VOLTAGE

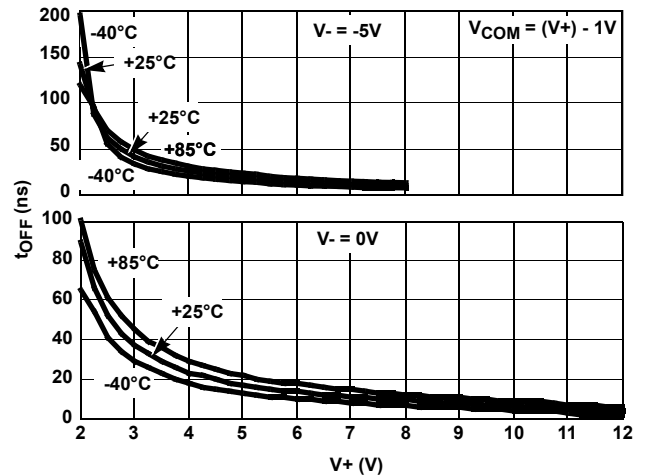

FIGURE 14. INHIBIT TURN-OFF TIME vs SUPPLY VOLTAGE

Typical Performance Curves $T_A = +25^\circ\text{C}$, Unless Otherwise Specified (Continued)

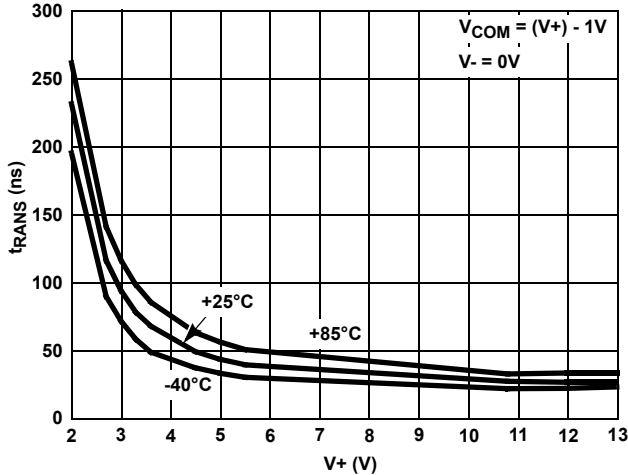

FIGURE 15. ADDRESS TRANS TIME vs SINGLE SUPPLY VOLTAGE

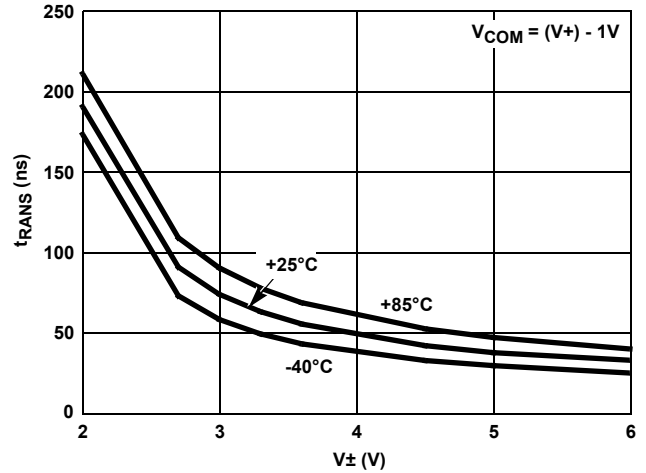

FIGURE 16. ADDRESS TRANS TIME vs DUAL SUPPLY VOLTAGE

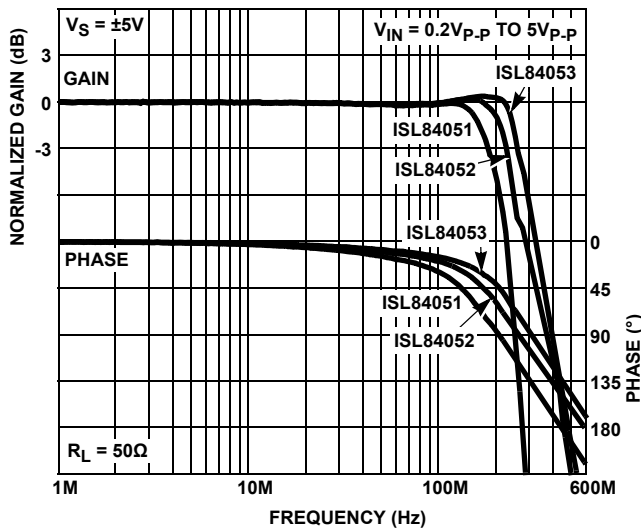

FIGURE 17. FREQUENCY RESPONSE

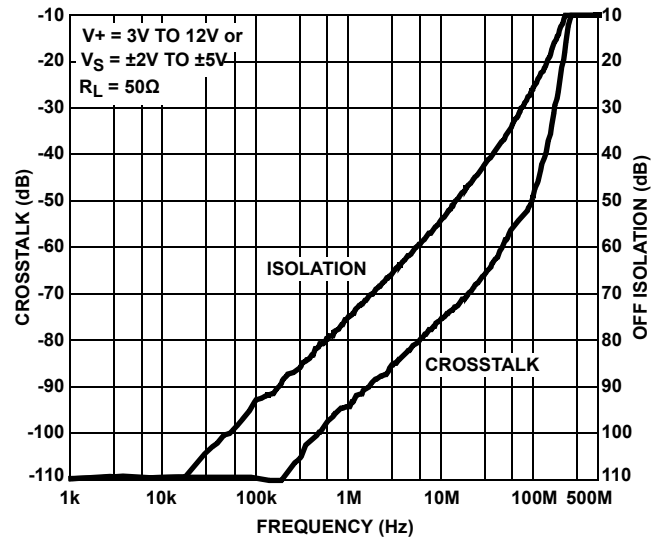

FIGURE 18. CROSSTALK AND OFF ISOLATION

Die Characteristics

SUBSTRATE POTENTIAL (POWERED UP):

V-

TRANSISTOR COUNT:

- ISL84051: 193
- ISL84052: 193
- ISL84053: 193

PROCESS:

Si Gate CMOS

Revision History

The revision history provided is for informational purposes only and is believed to be accurate, but not warranted. Please go to web to make sure you have the latest revision.

DATE	REVISION	CHANGE
05/02/11	FN6047.10	<ul style="list-style-type: none"> -Converted to new datasheet template. -Updated Intersil Trademark statement at bottom of page 1 per directive from Legal. -Added TSSOP Package option to ISL84053 in Pin Configuration and ordering information. -Updated ordering information by removing withdrawn and obsolete non pb-free parts: ISL84051IA, ISL84051IA-T, ISL84051IB, ISL84051IB-T, ISL84052IA, ISL84051IB, ISL84053IA-T Updated notes in ordering information -Updated "Parameters..." note in Electrical Specifications tables to new "Compliance..." note according to standards -M16.173 - Converted to new POD format by moving dimensions from table onto drawing and adding land pattern. No dimension changes. -Added Revision History and Products Information.

Products

Intersil Corporation is a leader in the design and manufacture of high-performance analog semiconductors. The Company's products address some of the industry's fastest growing markets, such as, flat panel displays, cell phones, handheld products, and notebooks. Intersil's product families address power management and analog signal processing functions. Go to www.intersil.com/products for a complete list of Intersil product families.

*For a complete listing of Applications, Related Documentation and Related Parts, please see the respective device information page on intersil.com: [ISL84051](http://www.intersil.com/products), [ISL84052](http://www.intersil.com/products), [ISL84053](http://www.intersil.com/products)

To report errors or suggestions for this datasheet, please go to: www.intersil.com/askourstaff

FITs are available from our website at: <http://rel.intersil.com/reports/search.php>

Small Outline Plastic Packages (SOIC)

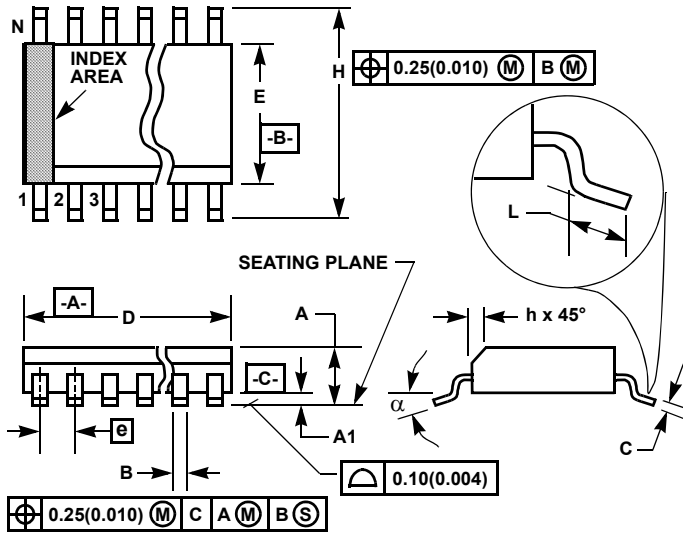

M16.15 (JEDEC MS-012-AC ISSUE C)
16 LEAD NARROW BODY SMALL OUTLINE PLASTIC PACKAGE

SYMBOL	INCHES		MILLIMETERS		NOTES
	MIN	MAX	MIN	MAX	
A	0.0532	0.0688	1.35	1.75	-
A1	0.0040	0.0098	0.10	0.25	-
B	0.013	0.020	0.33	0.51	9
C	0.0075	0.0098	0.19	0.25	-
D	0.3859	0.3937	9.80	10.00	3
E	0.1497	0.1574	3.80	4.00	4
e	0.050 BSC		1.27 BSC		-
H	0.2284	0.2440	5.80	6.20	-
h	0.0099	0.0196	0.25	0.50	5
L	0.016	0.050	0.40	1.27	6
N	16		16		7
alpha	0°	8°	0°	8°	-

NOTES:

1. Symbols are defined in the "MO Series Symbol List" in Section 2.2 of Publication Number 95.
2. Dimensioning and tolerancing per ANSI Y14.5M-1982.
3. Dimension "D" does not include mold flash, protrusions or gate burrs. Mold flash, protrusion and gate burrs shall not exceed 0.15mm (0.006 inch) per side.
4. Dimension "E" does not include interlead flash or protrusions. Interlead flash and protrusions shall not exceed 0.25mm (0.010 inch) per side.
5. The chamfer on the body is optional. If it is not present, a visual index feature must be located within the crosshatched area.
6. "L" is the length of terminal for soldering to a substrate.
7. "N" is the number of terminal positions.
8. Terminal numbers are shown for reference only.
9. The lead width "B", as measured 0.36mm (0.014 inch) or greater above the seating plane, shall not exceed a maximum value of 0.61mm (0.024 inch).
10. Controlling dimension: MILLIMETER. Converted inch dimensions are not necessarily exact.

Rev. 1 6/05

Package Outline Drawing

M16.173

16 LEAD THIN SHRINK SMALL OUTLINE PACKAGE (TSSOP)

Rev 2, 5/10

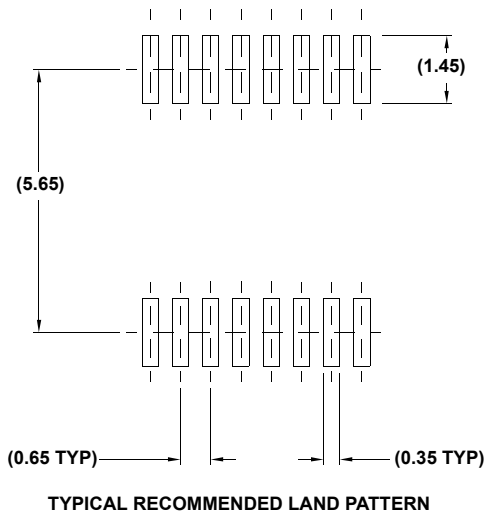
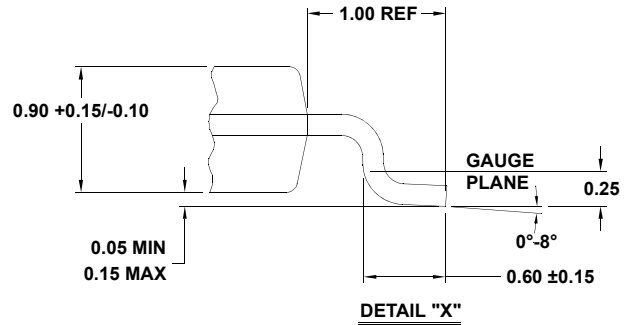
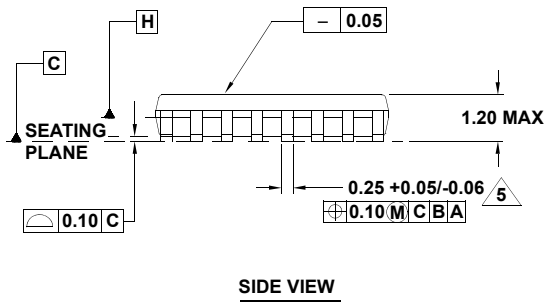
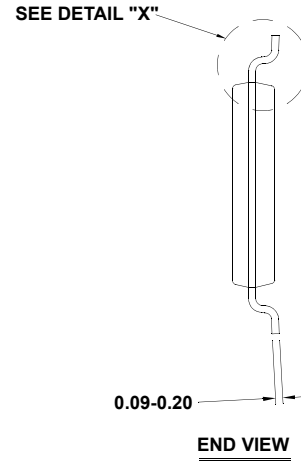
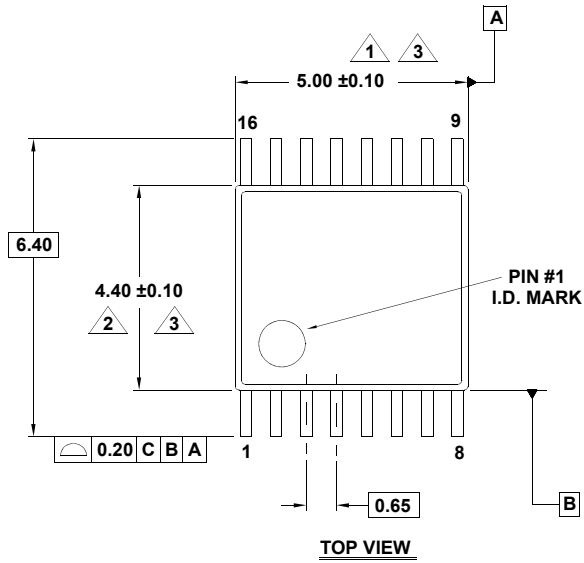

NOTES:

1. Dimension does not include mold flash, protrusions or gate burrs. Mold flash, protrusions or gate burrs shall not exceed 0.15 per side.
2. Dimension does not include interlead flash or protrusion. Interlead flash or protrusion shall not exceed 0.25 per side.
3. Dimensions are measured at datum plane H.
4. Dimensioning and tolerancing per ASME Y14.5M-1994.
5. Dimension does not include dambar protrusion. Allowable protrusion shall be 0.08mm total in excess of dimension at maximum material condition. Minimum space between protrusion and adjacent lead is 0.07mm.
6. Dimension in () are for reference only.
7. Conforms to JEDEC MO-153.

**Shrink Small Outline Plastic Packages (SSOP)
Quarter Size Outline Plastic Packages (QSOP)**

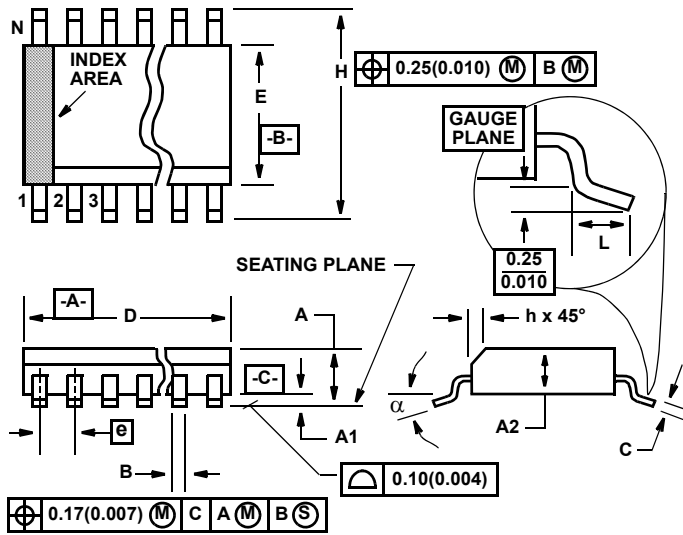

M16.15A
16 LEAD SHRINK SMALL OUTLINE PLASTIC PACKAGE
(0.150" WIDE BODY)

SYMBOL	INCHES		MILLIMETERS		NOTES
	MIN	MAX	MIN	MAX	
A	0.061	0.068	1.55	1.73	-
A1	0.004	0.0098	0.102	0.249	-
A2	0.055	0.061	1.40	1.55	-
B	0.008	0.012	0.20	0.31	9
C	0.0075	0.0098	0.191	0.249	-
D	0.189	0.196	4.80	4.98	3
E	0.150	0.157	3.81	3.99	4
e	0.025 BSC		0.635 BSC		-
H	0.230	0.244	5.84	6.20	-
h	0.010	0.016	0.25	0.41	5
L	0.016	0.035	0.41	0.89	6
N	16		16		7
α	0°	8°	0°	8°	-

NOTES:

1. Symbols are defined in the "MO Series Symbol List" in Section 2.2 of Publication Number 95.
2. Dimensioning and tolerancing per ANSI Y14.5M-1982.
3. Dimension "D" does not include mold flash, protrusions or gate burrs. Mold flash, protrusion and gate burrs shall not exceed 0.15mm (0.006 inch) per side.
4. Dimension "E" does not include interlead flash or protrusions. Interlead flash and protrusions shall not exceed 0.25mm (0.010 inch) per side.
5. The chamfer on the body is optional. If it is not present, a visual index feature must be located within the crosshatched area.
6. "L" is the length of terminal for soldering to a substrate.
7. "N" is the number of terminal positions.
8. Terminal numbers are shown for reference only.
9. Dimension "B" does not include dambar protrusion. Allowable dambar protrusion shall be 0.10mm (0.004 inch) total in excess of "B" dimension at maximum material condition.
10. Controlling dimension: INCHES. Converted millimeter dimensions are not necessarily exact.

Rev. 2 6/04

© Copyright Intersil Americas LLC 2003-2011. All Rights Reserved.
All trademarks and registered trademarks are the property of their respective owners.

For additional products, see www.intersil.com/en/products.html

Intersil products are manufactured, assembled and tested utilizing ISO9001 quality systems as noted in the quality certifications found at www.intersil.com/en/support/qualandreliability.html

Intersil products are sold by description only. Intersil may modify the circuit design and/or specifications of products at any time without notice, provided that such modification does not, in Intersil's sole judgment, affect the form, fit or function of the product. Accordingly, the reader is cautioned to verify that datasheets are current before placing orders. Information furnished by Intersil is believed to be accurate and reliable. However, no responsibility is assumed by Intersil or its subsidiaries for its use; nor for any infringements of patents or other rights of third parties which may result from its use. No license is granted by implication or otherwise under any patent or patent rights of Intersil or its subsidiaries.

For information regarding Intersil Corporation and its products, see www.intersil.com

Looking for pricing, stock, or lifecycle information?

Click below to explore more details on WIN SOURCE:

-  [View ISL84051IAZ-T on WIN SOURCE](#)
-  [Renesas Electronics America](#) Information

Optimize Your Supply Chain with WIN SOURCE Solutions

-  Global Sourcing Solution
-  Obsolete Management
-  Cost Control Management
-  Shortage Management
-  Alternative Solution
-  Excess Inventory Management