



**THE DATASHEET OF
MK22FN512VLL12R**



Kinetis K22F 512KB Flash

120 MHz Arm® Cortex®-M4 Based Microcontroller with FPU

The Kinetis K22 product family members are optimized for cost-sensitive applications requiring low-power, USB connectivity, and processing efficiency and high peripheral integration with a floating point unit. These devices share the comprehensive enablement and scalability of the Kinetis family.

This product offers:

- Run power consumption down to 156 μ A/MHz and static power consumption down to 3.8 μ A, full state retention and 6 μ S wakeup. Lowest static mode down to 140 nA.
- USB LS/FS OTG 2.0 with embedded 3.3 V, 120 mA LDO voltage regulator. USB FS device crystal-less functionality.

MK22FN512VDC12
MK22FN512VLL12
MK22FN512VLH12
MK22FN512VMP12
MK22FN512VFX12

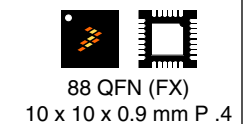
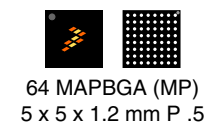
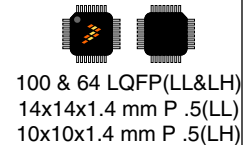
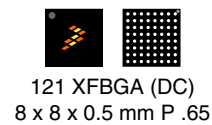

Performance

- 120 MHz Arm Cortex-M4 core with DSP instructions delivering 1.25 Dhrystone MIPS per MHz

Memories and memory interfaces

- 512 KB of embedded flash and 128 KB of RAM
- FlexBus external bus interface ¹
- Serial programming interface (EzPort)
- Preprogrammed Kinetis flashloader for one-time, in-system factory programming

Timers

- Two 8-ch general purpose/PWM timers
- Two 2-ch general purpose timers with quadrature decoder functionality
- Periodic interrupt timers
- 16-bit low-power timer
- Real-time clock with independent power domain
- Programmable delay block

Security and integrity modules

- Hardware CRC module
- 128-bit unique identification (ID) number per chip
- Hardware random-number generator
- Flash access control to protect proprietary software

Operating Characteristics

- Voltage range (including flash writes): 1.71 to 3.6 V
- Temperature range (ambient): -40 to 105°C

Analog modules

- Two 16-bit SAR ADCs (1.2 MS/s in 12bit mode)
- Two 12-bit DACs ²
- Two analog comparators (CMP) with 6-bit DAC
- Accurate internal voltage reference

System peripherals

- Flexible low-power modes, multiple wake-up sources
- 16-channel DMA controller
- Independent external and software watchdog monitor

Clocks

- Two crystal oscillators: 32 kHz (RTC) and 32-40 kHz or 3-32 MHz
- Three internal oscillators: 32 kHz, 4 MHz, & 48 MHz
- Multipurpose clock generator with PLL and FLL

Communication interfaces

- USB full/low-speed On-the-Go controller
- USB full-speed device crystal-less operation
- Two SPI modules and I2S module
- Three UART modules and one low-power UART
- Two I2C: Support for up to 1 Mbps operation

Human-machine interface

- Up to 81 general-purpose I/O (GPIO)

1. MK22FN512VFX12 (88QFN) does not support the FlexBus function.
2. Only MK22FN512VDC12 (121BGA) supports DAC0 and DAC1 function.

Ordering Information

Orderable Part Number	Part Number Marking	Memory Configuration	Package	Maximum number of I/O's
MK22FN512VDC12	M22J9VDC	<ul style="list-style-type: none"> • 512 KB Flash • 128 KB SRAM 	121 XFBGA (8x8x0.5mm)	81
MK22FN512VLL12	MK22FN512VLL12	<ul style="list-style-type: none"> • 512 KB Flash • 128 KB SRAM 	100 LQFP (14x14x1.7mm)	66
MK22FN512VLH12	MK22FN512VLH12	<ul style="list-style-type: none"> • 512 KB Flash • 128 KB SRAM 	64 LQFP (10x10x1.6mm)	40
MK22FN512VMP12	M22J9V	<ul style="list-style-type: none"> • 512 KB Flash • 128 KB SRAM 	64 MAPBGA (5x5x1.23mm)	40
MK22FN512VFX12	MK22FN512VFX12	<ul style="list-style-type: none"> • 512 KB Flash • 128 KB SRAM 	88 QFN (10x10x0.9mm)	60

Device Revision Number

Device Mask Set Number	SIM_SDID[REVID]	JTAG ID Register[PRN]
ON50M	0001	0001

Related Resources

Type	Description	Document
Selector Guide	The NXP Solution Advisor is a web-based tool that features interactive application wizards and a dynamic product selector	KINETISKMCUSELGD
Product Brief	The Product Brief contains concise overview/summary information to enable quick evaluation of a device for design suitability.	K22FPB
Reference Manual	The Reference Manual contains a comprehensive description of the structure and function (operation) of a device.	K22P121M120SF7RM
Data Sheet	The Data Sheet is this document. It includes electrical characteristics and signal connections.	K22P121M120SF7
Chip Errata	The chip mask set Errata provides additional or corrective information for a particular device mask set.	KINETIS_K_xN50M
Package drawing	Package dimensions are provided by part number: <ul style="list-style-type: none"> • MK22FN512VDC12 • MK22FN512VLL12 • MK22FN512VLH12 • MK22FN512VMP12 • MK22FN512VFX12 	Package drawing: <ul style="list-style-type: none"> • 98ASA00595D • 98ASS23308W • 98ASS23234W • 98ASA00420D • 98ASA00935D
Engineering Bulletin	This engineering bulletin gives connection recommendations specifically for microcontrollers in DFN and QFN packages.	Electrical Connection Recommendations for the Exposed Pad on QFN and DFN Packages.

Figure 1 shows the functional modules in the chip.

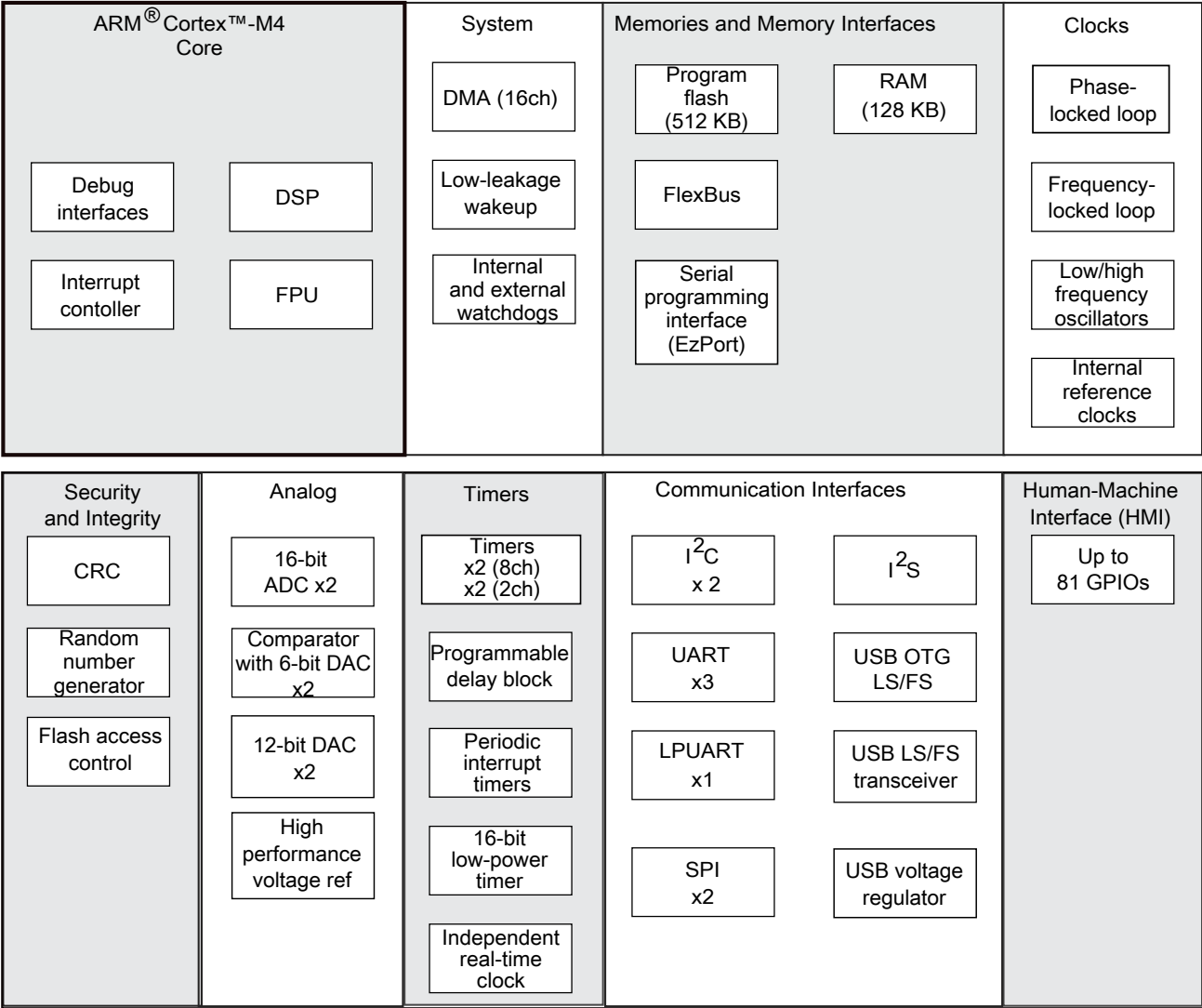

Figure 1. Functional block diagram

Table of Contents

1	Ratings.....	5	3.5	Security and integrity modules.....	38
1.1	Thermal handling ratings.....	5	3.6	Analog.....	38
1.2	Moisture handling ratings.....	5	3.6.1	ADC electrical specifications.....	39
1.3	ESD handling ratings.....	5	3.6.2	CMP and 6-bit DAC electrical specifications.....	44
1.4	Voltage and current operating ratings.....	5	3.6.3	12-bit DAC electrical characteristics.....	46
2	General.....	6	3.6.4	Voltage reference electrical specifications.....	49
2.1	AC electrical characteristics.....	6	3.7	Timers.....	50
2.2	Nonswitching electrical specifications.....	6	3.8	Communication interfaces.....	50
2.2.1	Voltage and current operating requirements.....	6	3.8.1	USB electrical specifications.....	51
2.2.2	LVD and POR operating requirements.....	7	3.8.2	USB VREG electrical specifications.....	51
2.2.3	Voltage and current operating behaviors.....	8	3.8.3	DSPI switching specifications (limited voltage range).....	52
2.2.4	Power mode transition operating behaviors.....	9	3.8.4	DSPI switching specifications (full voltage range)..	54
2.2.5	Power consumption operating behaviors.....	10	3.8.5	Inter-Integrated Circuit Interface (I2C) timing.....	55
2.2.6	EMC radiated emissions operating behaviors.....	17	3.8.6	UART switching specifications.....	57
2.2.7	Designing with radiated emissions in mind.....	18	3.8.7	I2S/SAI switching specifications.....	57
2.2.8	Capacitance attributes.....	18	4	Dimensions.....	63
2.3	Switching specifications.....	18	4.1	Obtaining package dimensions.....	63
2.3.1	Device clock specifications.....	18	5	Pinout.....	64
2.3.2	General switching specifications.....	19	5.1	K22F Signal Multiplexing and Pin Assignments.....	64
2.4	Thermal specifications.....	20	5.2	Recommended connection for unused analog and digital pins.....	70
2.4.1	Thermal operating requirements.....	20	5.3	K22 Pinouts.....	71
2.4.2	Thermal attributes.....	20	6	Part identification.....	76
2.4.3	Thermal attributes for 88 QFN.....	21	6.1	Description.....	76
3	Peripheral operating requirements and behaviors.....	22	6.2	Format.....	76
3.1	Core modules.....	22	6.3	Fields.....	77
3.1.1	SWD electricals	22	6.4	Example.....	77
3.1.2	JTAG electricals.....	23	6.5	Package Markings.....	78
3.2	System modules.....	26	7	Terminology and guidelines.....	79
3.3	Clock modules.....	26	7.1	Definitions.....	79
3.3.1	MCG specifications.....	26	7.2	Examples.....	79
3.3.2	IRC48M specifications.....	29	7.3	Typical-value conditions.....	80
3.3.3	Oscillator electrical specifications.....	29	7.4	Relationship between ratings and operating requirements.	80
3.3.4	32 kHz oscillator electrical characteristics.....	32	7.5	Guidelines for ratings and operating requirements.....	81
3.4	Memories and memory interfaces.....	32	8	Revision History.....	81
3.4.1	Flash electrical specifications.....	32			
3.4.2	EzPort switching specifications.....	34			
3.4.3	Flexbus switching specifications.....	35			

1 Ratings

1.1 Thermal handling ratings

Symbol	Description	Min.	Max.	Unit	Notes
T _{STG}	Storage temperature	-55	150	°C	1
T _{SDR}	Solder temperature, lead-free	—	260	°C	2

1. Determined according to JEDEC Standard JESD22-A103, *High Temperature Storage Life*.
2. Determined according to IPC/JEDEC Standard J-STD-020, *Moisture/Reflow Sensitivity Classification for Nonhermetic Solid State Surface Mount Devices*.

1.2 Moisture handling ratings

Symbol	Description	Min.	Max.	Unit	Notes
MSL	Moisture sensitivity level	—	3	—	1

1. Determined according to IPC/JEDEC Standard J-STD-020, *Moisture/Reflow Sensitivity Classification for Nonhermetic Solid State Surface Mount Devices*.

1.3 ESD handling ratings

Symbol	Description	Min.	Max.	Unit	Notes
V _{HBM}	Electrostatic discharge voltage, human body model	-2000	+2000	V	1
V _{CDM}	Electrostatic discharge voltage, charged-device model	-500	+500	V	2
I _{LAT}	Latch-up current at ambient temperature of 105°C	-100	+100	mA	3

1. Determined according to JEDEC Standard JESD22-A114, *Electrostatic Discharge (ESD) Sensitivity Testing Human Body Model (HBM)*.
2. Determined according to JEDEC Standard JESD22-C101, *Field-Induced Charged-Device Model Test Method for Electrostatic-Discharge-Withstand Thresholds of Microelectronic Components*.
3. Determined according to JEDEC Standard JESD78, *IC Latch-Up Test*.

1.4 Voltage and current operating ratings

General

Symbol	Description	Min.	Max.	Unit
V_{DD}	Digital supply voltage	-0.3	3.8	V
I_{DD}	Digital supply current	—	169	mA
V_{IN}^1	Input voltage (except VBAT domain pins, and USB0)	-0.3	3.8	V
I_D	Maximum current single pin limit (digital output)	-25	25	mA
V_{DDA}	Analog supply voltage	-0.3	3.8	V
V_{USB0_DP}	USB0_DP input voltage	-0.3	3.63	V
V_{USB0_DM}	USB0_DM input voltage	-0.3	3.63	V
VREGIN	USB regulator input	-0.3	6.0	V
V_{BAT}	RTC supply voltage	-0.3	3.8	V
$V_{IO_BAT}^2$	VBAT domain input voltage	-0.3	3.8	V

1. Includes ADC, CMP, and RESET_b inputs
2. VBAT domain pins include EXTAL32, XTAL32, and RTC_WAKEUP_b

2 General

2.1 AC electrical characteristics

Unless otherwise specified, propagation delays are measured from the 50% to the 50% point, and rise and fall times are measured at the 20% and 80% points, as shown in the following figure.

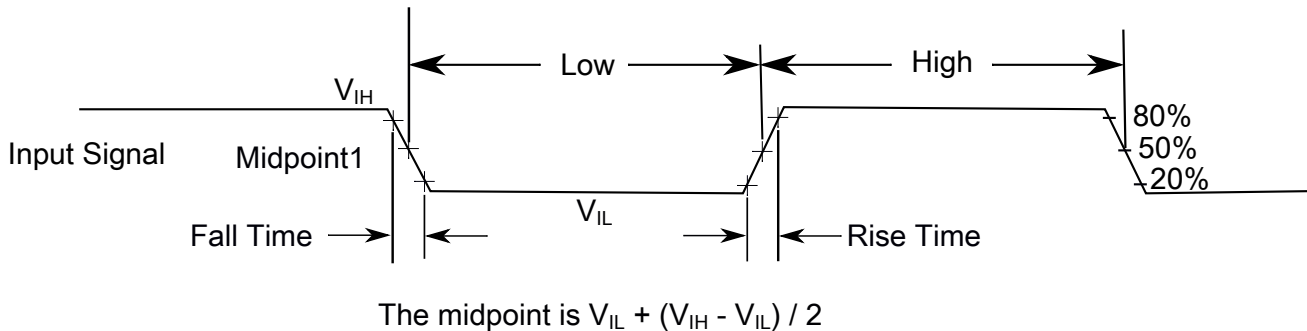

Figure 2. Input signal measurement reference

2.2 Nonswitching electrical specifications

2.2.1 Voltage and current operating requirements

Table 1. Voltage and current operating requirements

Symbol	Description	Min.	Max.	Unit	Notes
V _{DD}	Supply voltage	1.71	3.6	V	
V _{DDA}	Analog supply voltage	1.71	3.6	V	
V _{DD} – V _{DDA}	V _{DD} -to-V _{DDA} differential voltage	-0.1	0.1	V	
V _{SS} – V _{SSA}	V _{SS} -to-V _{SSA} differential voltage	-0.1	0.1	V	
V _{BAT}	RTC battery supply voltage	1.71	3.6	V	
V _{BAT} :SR _{PWR}	Power Slew Rate	—	500	V/ms	1
V _{IH}	Input high voltage <ul style="list-style-type: none"> • 2.7 V ≤ V_{DD} ≤ 3.6 V • 1.7 V ≤ V_{DD} ≤ 2.7 V 	0.7 × V _{DD} 0.75 × V _{DD}	— —	V V	
V _{IL}	Input low voltage <ul style="list-style-type: none"> • 2.7 V ≤ V_{DD} ≤ 3.6 V • 1.7 V ≤ V_{DD} ≤ 2.7 V 	— —	0.35 × V _{DD} 0.3 × V _{DD}	V V	
V _{HYS}	Input hysteresis	0.06 × V _{DD}	—	V	
I _{ICIO}	Analog and I/O pin DC injection current — single pin <ul style="list-style-type: none"> • V_{IN} < V_{SS}-0.3V (Negative current injection) 	-3	—	mA	2
I _{ICcont}	Contiguous pin DC injection current —regional limit, includes sum of negative injection currents or sum of positive injection currents of 16 contiguous pins <ul style="list-style-type: none"> • Negative current injection 	-25	—	mA	
V _{ODPU}	Open drain pullup voltage level	V _{DD}	V _{DD}	V	3
V _{RAM}	V _{DD} voltage required to retain RAM	1.2	—	V	
V _{RFVBAT}	V _{BAT} voltage required to retain the VBAT register file	V _{POR_VBAT}	—	V	

1. Applies to all voltages. Slew rate starts at 0 V
2. All analog and I/O pins are internally clamped to V_{SS} through ESD protection diodes. If V_{IN} is less than -0.3 V, a current limiting resistor is required. The negative DC injection current limiting resistor is calculated as R=-0.3V - V_{IN}/I_{ICIO}. The actual resistor value should be an order of magnitude higher to tolerate transient voltages.
3. Open drain outputs must be pulled to VDD.

2.2.2 LVD and POR operating requirements

Table 2. V_{DD} supply LVD and POR operating requirements

Symbol	Description	Min.	Typ.	Max.	Unit	Notes
V _{POR}	Falling VDD POR detect voltage	0.8	1.1	1.5	V	
V _{LVDH}	Falling low-voltage detect threshold — high range (LVDV=01)	2.48	2.56	2.64	V	

Table continues on the next page...

Table 2. V_{DD} supply LVD and POR operating requirements (continued)

Symbol	Description	Min.	Typ.	Max.	Unit	Notes
V _{LVW1H}	Low-voltage warning thresholds — high range <ul style="list-style-type: none"> Level 1 falling (LVWV=00) Level 2 falling (LVWV=01) Level 3 falling (LVWV=10) Level 4 falling (LVWV=11) 	2.62	2.70	2.78	V	1
V _{LVW2H}		2.72	2.80	2.88	V	
V _{LVW3H}		2.82	2.90	2.98	V	
V _{LVW4H}		2.92	3.00	3.08	V	
V _{HYSH}	Low-voltage inhibit reset/recover hysteresis — high range	—	80	—	mV	
V _{LVDL}	Falling low-voltage detect threshold — low range (LVDV=00)	1.54	1.60	1.66	V	
V _{LVW1L}	Low-voltage warning thresholds — low range <ul style="list-style-type: none"> Level 1 falling (LVWV=00) Level 2 falling (LVWV=01) Level 3 falling (LVWV=10) Level 4 falling (LVWV=11) 	1.74	1.80	1.86	V	1
V _{LVW2L}		1.84	1.90	1.96	V	
V _{LVW3L}		1.94	2.00	2.06	V	
V _{LVW4L}		2.04	2.10	2.16	V	
V _{HYSL}	Low-voltage inhibit reset/recover hysteresis — low range	—	60	—	mV	
V _{BG}	Bandgap voltage reference	0.97	1.00	1.03	V	
t _{LPO}	Internal low power oscillator period — factory trimmed	900	1000	1100	μs	

1. Rising threshold is the sum of falling threshold and hysteresis voltage.

Table 3. VBAT power operating requirements

Symbol	Description	Min.	Typ.	Max.	Unit	Notes
V _{POR_VBAT}	Falling VBAT supply POR detect voltage	0.8	1.1	1.5	V	

2.2.3 Voltage and current operating behaviors

Table 4. Voltage and current operating behaviors

Symbol	Description	Min.	Typ.	Max.	Unit	Notes
V _{OH}	Output high voltage — Normal drive pad except RESET_B 2.7 V ≤ V _{DD} ≤ 3.6 V, I _{OH} = -5 mA	V _{DD} - 0.5	—	—	V	1
		V _{DD} - 0.5	—	—	V	
V _{OH}	Output high voltage — High drive pad except RESET_B 2.7 V ≤ V _{DD} ≤ 3.6 V, I _{OH} = -20 mA	V _{DD} - 0.5	—	—	V	1
		V _{DD} - 0.5	—	—	V	

Table continues on the next page...

Table 4. Voltage and current operating behaviors (continued)

Symbol	Description	Min.	Typ.	Max.	Unit	Notes
	$1.71\text{ V} \leq V_{DD} \leq 2.7\text{ V}$, $I_{OH} = -10\text{ mA}$	$V_{DD} - 0.5$	—	—	V	
I_{OHT}	Output high current total for all ports	—	—	100	mA	
V_{OL}	Output low voltage — Normal drive pad except RESET_B $2.7\text{ V} \leq V_{DD} \leq 3.6\text{ V}$, $I_{OL} = 5\text{ mA}$ $1.71\text{ V} \leq V_{DD} \leq 2.7\text{ V}$, $I_{OL} = 2.5\text{ mA}$	— —	— —	0.5 0.5	V V	1
V_{OL}	Output low voltage — High drive pad except RESET_B $2.7\text{ V} \leq V_{DD} \leq 3.6\text{ V}$, $I_{OL} = 20\text{ mA}$ $1.71\text{ V} \leq V_{DD} \leq 2.7\text{ V}$, $I_{OL} = 10\text{ mA}$	— —	— —	0.5 0.5	V V	1
V_{OL}	Output low voltage — RESET_B $2.7\text{ V} \leq V_{DD} \leq 3.6\text{ V}$, $I_{OL} = 3\text{ mA}$ $1.71\text{ V} \leq V_{DD} \leq 2.7\text{ V}$, $I_{OL} = 1.5\text{ mA}$	— —	— —	0.5 0.5	V V	
I_{OLT}	Output low current total for all ports	—	—	100	mA	
I_{IN}	Input leakage current (per pin) for full temperature range All pins other than high drive port pins High drive port pins	— —	0.002 0.004	0.5 0.5	μA μA	1, 2
I_{IN}	Input leakage current (total all pins) for full temperature range	—	—	1.0	μA	2
R_{PU}	Internal pullup resistors	20	—	50	k Ω	3
R_{PD}	Internal pulldown resistors	20	—	50	k Ω	4

1. PTB0, PTB1, PTC3, PTC4, PTD4, PTD5, PTD6, and PTD7 I/O have both high drive and normal drive capability selected by the associated PTx_PCRn[DSE] control bit. All other GPIOs are normal drive only.
2. Measured at $V_{DD}=3.6\text{ V}$
3. Measured at V_{DD} supply voltage = V_{DD} min and $V_{input} = V_{SS}$
4. Measured at V_{DD} supply voltage = V_{DD} min and $V_{input} = V_{DD}$

2.2.4 Power mode transition operating behaviors

All specifications except t_{POR} , and $V_{LLSx} \rightarrow \text{RUN}$ recovery times in the following table assume this clock configuration:

- CPU and system clocks = 80 MHz
- Bus clock = 40 MHz
- FlexBus clock = 20 MHz
- Flash clock = 20 MHz
- MCG mode: FEI

Table 5. Power mode transition operating behaviors

Symbol	Description	Min.	Typ.	Max.	Unit	Notes
t _{POR}	After a POR event, amount of time from the point V _{DD} reaches 1.71 V to execution of the first instruction across the operating temperature range of the chip.	—	—	300	μs	1
	• VLLS0 → RUN	—	—	140	μs	
	• VLLS1 → RUN	—	—	140	μs	
	• VLLS2 → RUN	—	—	80	μs	
	• VLLS3 → RUN	—	—	80	μs	
	• LLS2 → RUN	—	—	6	μs	
	• LLS3 → RUN	—	—	6	μs	
	• VLPS → RUN	—	—	5.7	μs	
	• STOP → RUN	—	—	5.7	μs	

1. Normal boot (FTFA_OPT[LPBOOT]=1)

2.2.5 Power consumption operating behaviors

The current parameters in the table below are derived from code executing a while(1) loop from flash, unless otherwise noted.

The IDD typical values represent the statistical mean at 25°C, and the IDD maximum values for RUN, WAIT, VLPR, and VLPW represent data collected at 125°C junction temperature unless otherwise noted. The maximum values represent characterized results equivalent to the mean plus three times the standard deviation (mean + 3 sigma).

Table 6. Power consumption operating behaviors

Symbol	Description	Min.	Typ.	Max.	Unit	Notes
I _{DDA}	Analog supply current	—	—	See note	mA	1

Table continues on the next page...

Table 6. Power consumption operating behaviors (continued)

Symbol	Description	Min.	Typ.	Max.	Unit	Notes
I _{DD_HSRUN}	High Speed Run mode current - all peripheral clocks disabled, CoreMark benchmark code executing from flash @ 1.8V @ 3.0V	—	28.0	29.33	mA	2, 3, 4
		—	28.0	29.33	mA	
I _{DD_HSRUN}	High Speed Run mode current - all peripheral clocks disabled, code executing from flash @ 1.8V @ 3.0V	—	25.6	26.93	mA	2
		—	25.7	27.03	mA	
I _{DD_HSRUN}	High Speed Run mode current — all peripheral clocks enabled, code executing from flash @ 1.8V @ 3.0V	—	35.5	36.83	mA	5
		—	35.6	36.93	mA	
I _{DD_RUN}	Run mode current in Compute operation — CoreMark benchmark code executing from flash @ 1.8V @ 3.0V	—	17.5	18.83	mA	3, 4, 6
		—	17.5	18.83	mA	
I _{DD_RUN}	Run mode current in Compute operation — code executing from flash @ 1.8V @ 3.0V	—	15.10	17.10	mA	6
		—	15.10	17.33	mA	
I _{DD_RUN}	Run mode current — all peripheral clocks disabled, code executing from flash @ 1.8V @ 3.0V	—	16.6	17.93	mA	7
		—	16.8	18.13	mA	
I _{DD_RUN}	Run mode current — all peripheral clocks enabled, code executing from flash @ 1.8V @ 3.0V • @ 25°C • @ 70°C • @ 85°C • @ 105°C	—	22.8	24.13	mA	8
		—	22.9	24.23	mA	
		—	23.1	24.43	mA	
		—	23.5	24.83	mA	
		—	23.8	25.13	mA	
I _{DD_RUN}	Run mode current — Compute operation, code executing from flash @ 1.8V @ 3.0V • @ 25°C • @ 70°C	—	15.1	16.43	mA	9
		—	15.1	16.43	mA	
		—	15.4	16.73	mA	
		—	15.4	16.73	mA	

Table continues on the next page...

Table 6. Power consumption operating behaviors (continued)

Symbol	Description	Min.	Typ.	Max.	Unit	Notes
	<ul style="list-style-type: none"> @ 85°C @ 105°C 	—	15.6	16.93	mA	
I _{DD_WAIT}	Wait mode high frequency current at 3.0 V — all peripheral clocks disabled	—	9.3	10.63	mA	7
I _{DD_WAIT}	Wait mode reduced frequency current at 3.0 V — all peripheral clocks disabled	—	5.4	6.73	mA	10
I _{DD_VLPR}	Very-low-power run mode current in Compute operation — CoreMark benchmark code executing from flash					
	@ 1.8V	—	0.88	1.02	mA	3, 4, 11
	@ 3.0V	—	0.89	1.03	mA	
I _{DD_VLPR}	Very-low-power run mode current in Compute operation, code executing from flash					
	@ 1.8V	—	0.62	0.77	mA	11
	@ 3.0V	—	0.63	0.77	mA	
I _{DD_VLPR}	Very-low-power run mode current at 3.0 V — all peripheral clocks disabled	—	0.76	0.90	mA	12
I _{DD_VLPR}	Very-low-power run mode current at 3.0 V — all peripheral clocks enabled	—	1.2	1.34	mA	13
I _{DD_VLPW}	Very-low-power wait mode current at 3.0 V — all peripheral clocks disabled	—	0.45	0.59	mA	14
I _{DD_STOP}	Stop mode current at 3.0 V					
	@ -40°C to 25°C	—	0.28	0.37	mA	
	@ 70°C	—	0.34	0.51	mA	
	@ 85°C	—	0.38	0.55	mA	
	@ 105°C	—	0.50	0.80	mA	
I _{DD_VLPS}	Very-low-power stop mode current at 3.0 V					
	@ -40°C to 25°C	—	8.7	18.10	μA	
	@ 70°C	—	31.1	79.55	μA	
	@ 85°C	—	50.3	110.15	μA	
	@ 105°C	—	98.6	238.30	μA	
I _{DD_LLS3}	Low leakage stop mode 3 current at 3.0 V					
	@ -40°C to 25°C	—	3.8	5.65	μA	
	@ 70°C	—	12.5	28.75	μA	
	@ 85°C	—	20.2	47.60	μA	
	@ 105°C	—	39.5	91.25	μA	
I _{DD_LLS2}	Low leakage stop mode 2 current at 3.0 V					
	@ -40°C to 25°C	—	3.0	4.10	μA	
	@ 70°C	—	7.8	16.40	μA	
	@ 85°C	—	12.3	30.15	μA	

Table continues on the next page...

Table 6. Power consumption operating behaviors (continued)

Symbol	Description	Min.	Typ.	Max.	Unit	Notes
	@ 105°C	—	23.6	55.30	μA	
I _{DD_VLLS3}	Very low-leakage stop mode 3 current at 3.0 V @ -40°C to 25°C @ 70°C @ 85°C @ 105°C	— — — —	2.8 9.5 15.3 30.1	3.95 21.25 34.65 66.05	μA μA μA μA	
I _{DD_VLLS2}	Very low-leakage stop mode 2 current at 3.0 V @ -40°C to 25°C @ 70°C @ 85°C @ 105°C	— — — —	1.9 4.5 6.8 13.0	2.45 8.50 12.15 25.50	μA μA μA μA	
I _{DD_VLLS1}	Very low-leakage stop mode 1 current at 3.0 V @ -40°C to 25°C @ 70°C @ 85°C @ 105°C	— — — —	0.73 1.8 3.0 5.9	1.42 3.90 5.25 10.80	μA μA μA μA	
I _{DD_VLLS0}	Very low-leakage stop mode 0 current at 3.0 V with POR detect circuit enabled @ -40°C to 25°C @ 70°C @ 85°C @ 105°C	— — — —	0.43 1.4 2.6 5.4	0.55 2.45 4.00 9.30	μA μA μA μA	
I _{DD_VLLS0}	Very low-leakage stop mode 0 current at 3.0 V with POR detect circuit disabled @ -40°C to 25°C @ 70°C @ 85°C @ 105°C	— — — —	0.14 1.1 2.3 5.1	0.24 2.15 3.85 9.00	μA μA μA μA	
I _{DD_VBAT}	Average current with RTC and 32kHz disabled at 3.0 V @ -40°C to 25°C @ 70°C @ 85°C @ 105°C	— — — —	0.18 0.66 1.52 2.92	0.21 0.86 2.24 4.30	μA μA μA μA	
I _{DD_VBAT}	Average current when CPU is not accessing RTC registers @ 1.8V • @ -40°C to 25°C • @ 70°C	— — —	0.59 1.00 1.76	0.70 1.3 2.59	μA μA μA	15

Table 6. Power consumption operating behaviors

Symbol	Description	Min.	Typ.	Max.	Unit	Notes
	<ul style="list-style-type: none"> • @ 85°C • @ 105°C 	—	3.00	4.42	μA	
	@ 3.0 V	—	0.71	0.84	μA	
	<ul style="list-style-type: none"> • @ -40°C to 25°C • @ 70°C • @ 85°C • @ 105°C 	—	1.22	1.59	μA	
		—	2.08	3.06	μA	
		—	3.50	5.15	μA	

1. The analog supply current is the sum of the active or disabled current for each of the analog modules on the device. See each module's specification for its supply current.
2. 120MHz core and system clock, 60MHz bus clock, 24MHz FlexBus clock, and 24MHz flash clock. MCG configured for PEE mode. All peripheral clocks disabled.
3. Cache on and prefetch on, low compiler optimization.
4. Coremark benchmark compiled using IAR 7.2 with optimization level low.
5. 120MHz core and system clock, 60MHz bus clock, 24MHz FlexBus clock, and 24MHz flash clock. MCG configured for PEE mode. All peripheral clocks enabled.
6. 80 MHz core and system clock, 40 MHz bus clock, and 26.67 MHz flash clock. MCG configured for PEE mode. Compute operation.
7. 80MHz core and system clock, 40MHz bus clock, 20MHz FlexBus clock, and 26.67MHz flash clock. MCG configured for FEI mode. All peripheral clocks disabled.
8. 80MHz core and system clock, 40MHz bus clock, 20MHz FlexBus clock, and 26.67MHz flash clock. MCG configured for FEI mode. All peripheral clocks enabled.
9. 80MHz core and system clock, 40MHz bus clock, and 26.67MHz flash clock. MCG configured for FEI mode. Compute operation.
10. 25MHz core and system clock, 25MHz bus clock, and 25MHz FlexBus and flash clock. MCG configured for FEI mode.
11. 4 MHz core, system, FlexBus, and bus clock and 1MHz flash clock. MCG configured for BLPE mode. Compute operation. Code executing from flash.
12. 4 MHz core, system, FlexBus, and bus clock and 1MHz flash clock. MCG configured for BLPE mode. All peripheral clocks disabled. Code executing from flash.
13. 4 MHz core, system, FlexBus, and bus clock and 1MHz flash clock. MCG configured for BLPE mode. All peripheral clocks enabled but peripherals are not in active operation. Code executing from flash.
14. 4 MHz core, system, FlexBus, and bus clock and 1MHz flash clock. MCG configured for BLPE mode. All peripheral clocks disabled.
15. Includes 32kHz oscillator current and RTC operation.

Table 7. Low power mode peripheral adders—typical value

Symbol	Description	Temperature (°C)						Unit
		-40	25	50	70	85	105	
I _{REFSTEN4MHz}	4 MHz internal reference clock (IRC) adder. Measured by entering STOP or VLPS mode with 4 MHz IRC enabled.	56	56	56	56	56	56	μA
I _{REFSTEN32KHz}	32 kHz internal reference clock (IRC) adder. Measured by entering STOP mode with the 32 kHz IRC enabled.	52	52	52	52	52	52	μA
I _{REFSTEN4MHz}	External 4 MHz crystal clock adder. Measured by entering STOP or VLPS mode with the crystal enabled.	206	228	237	245	251	258	uA

Table continues on the next page...

Table 7. Low power mode peripheral adders—typical value (continued)

Symbol	Description	Temperature (°C)						Unit
		-40	25	50	70	85	105	
I _{EREFSTEN32KHZ}	External 32 kHz crystal clock adder by means of the OSC0_CR[EREFSTEN and EREFSTEN] bits. Measured by entering all modes with the crystal enabled.							
	VLLS1	440	490	540	560	570	580	nA
	VLLS3	440	490	540	560	570	580	
	LLS	490	490	540	560	570	680	
	VLPS	510	560	560	560	610	680	
	STOP	510	560	560	560	610	680	
I _{48MIRC}	48 Mhz internal reference clock	350	350	350	350	350	350	μA
I _{CMP}	CMP peripheral adder measured by placing the device in VLLS1 mode with CMP enabled using the 6-bit DAC and a single external input for compare. Includes 6-bit DAC power consumption.	22	22	22	22	22	22	μA
I _{RTC}	RTC peripheral adder measured by placing the device in VLLS1 mode with external 32 kHz crystal enabled by means of the RTC_CR[OSCE] bit and the RTC ALARM set for 1 minute. Includes ERCLK32K (32 kHz external crystal) power consumption.	432	357	388	475	532	810	nA
I _{UART}	UART peripheral adder measured by placing the device in STOP or VLPS mode with selected clock source waiting for RX data at 115200 baud rate. Includes selected clock source power consumption.							
	MCGIRCLK (4 MHz internal reference clock)	66	66	66	66	66	66	μA
	>OSCERCLK (4 MHz external crystal)	214	237	246	254	260	268	
I _{BG}	Bandgap adder when BGEN bit is set and device is placed in VLPx, LLS, or VLLSx mode.	45	45	45	45	45	45	μA
I _{ADC}	ADC peripheral adder combining the measured values at V _{DD} and V _{DDA} by placing the device in STOP or VLPS mode. ADC is configured for low power mode using the internal clock and continuous conversions.	42	42	42	42	42	42	μA

2.2.5.1 Diagram: Typical IDD_RUN operating behavior

The following data was measured under these conditions:

- MCG in FBE mode for 50 MHz and lower frequencies. MCG in FEE mode at frequencies between 50 MHz and 100MHz. MCG in PEE mode at frequencies greater than 100 MHz.
- USB regulator disabled
- No GPIOs toggled
- Code execution from flash with cache enabled
- For the ALLOFF curve, all peripheral clocks are disabled except FTFA

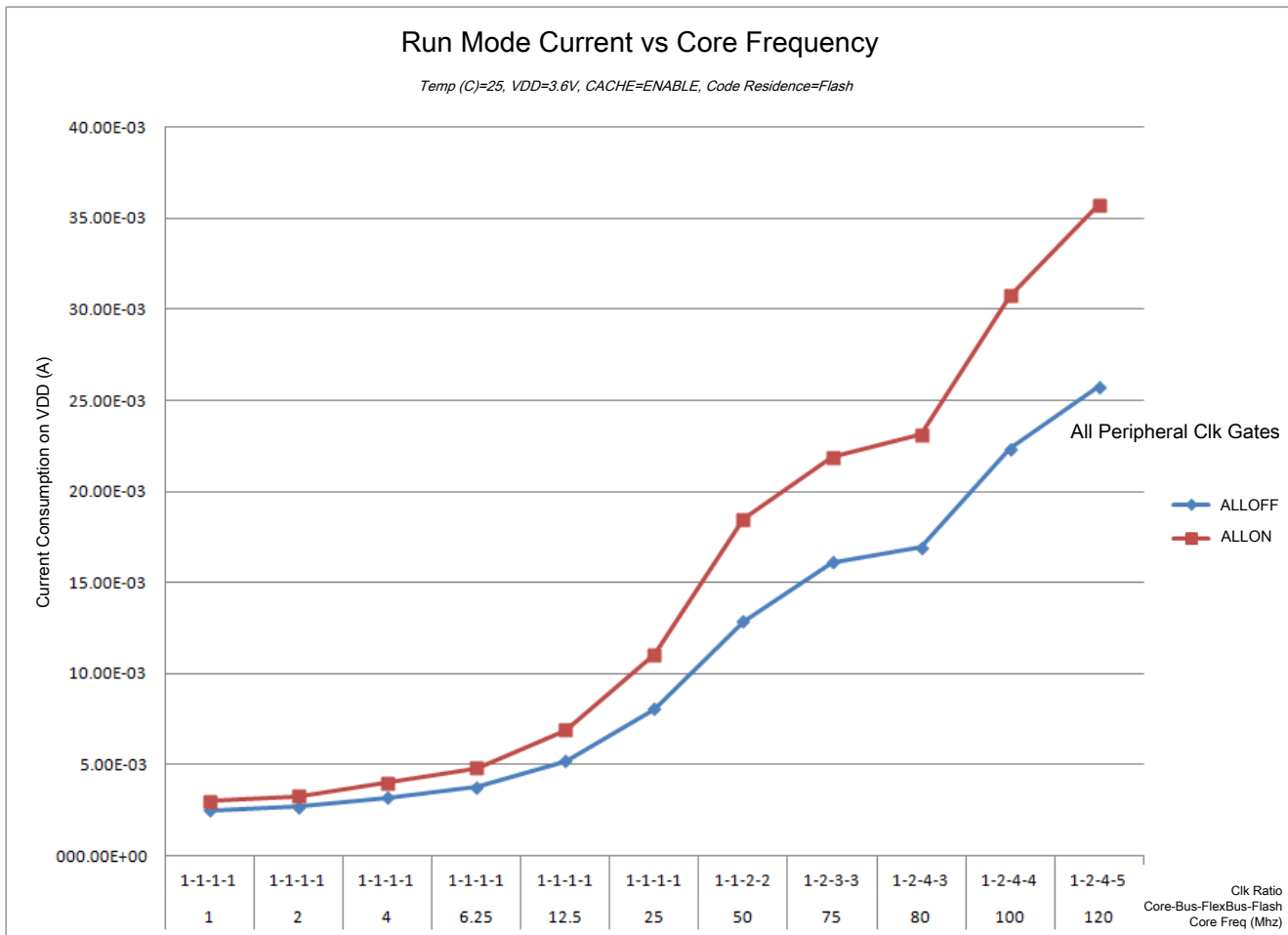

Figure 3. Run mode supply current vs. core frequency

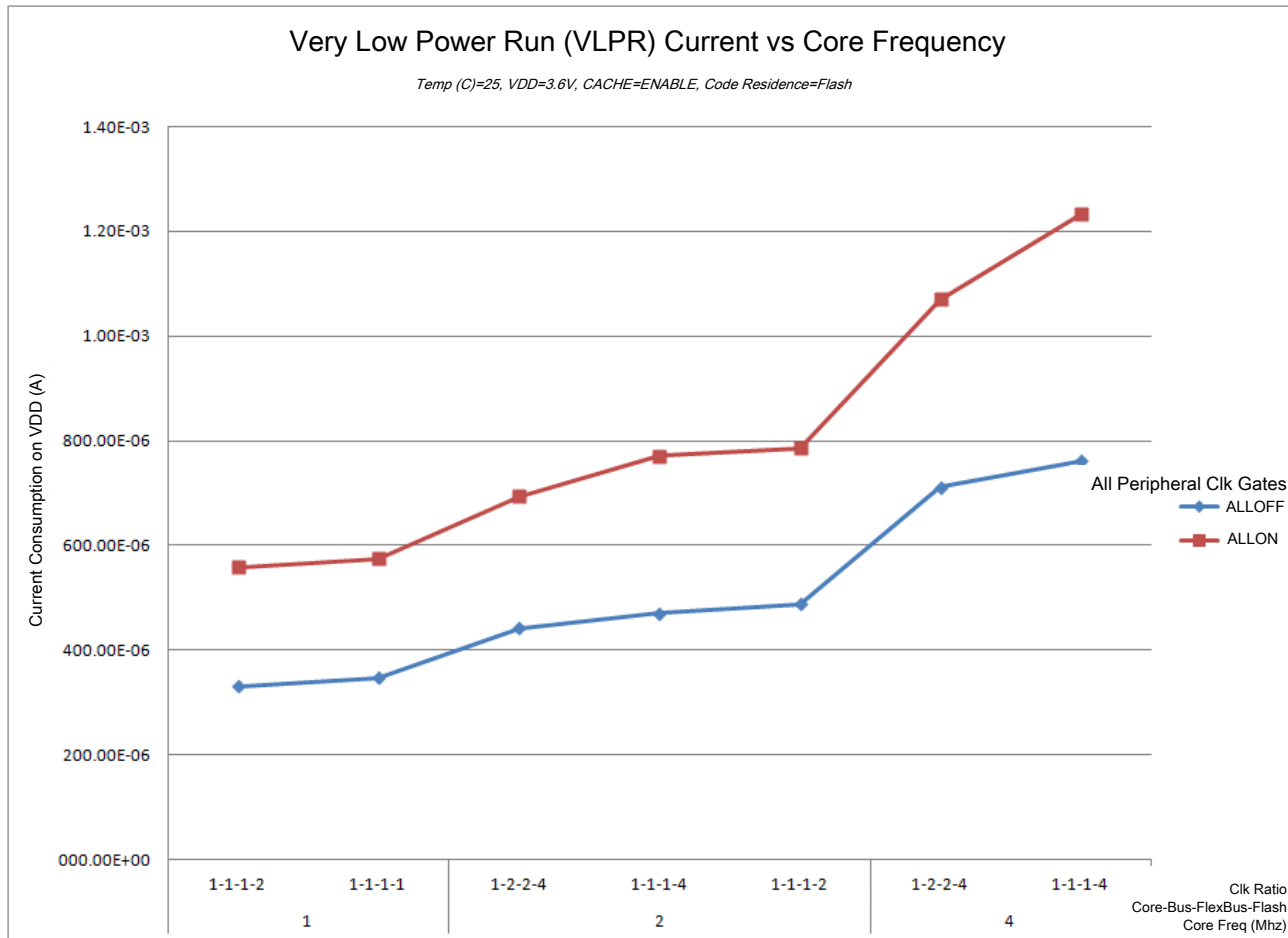

Figure 4. VLPR mode supply current vs. core frequency

2.2.6 EMC radiated emissions operating behaviors

Table 8. EMC radiated emissions operating behaviors for 64 LQFP package

Parameter	Conditions	Clocks	Frequency range	Level (Typ.)	Unit	Notes
V _{EME}	Device configuration, test conditions and EM testing per standard IEC 61967-2. Supply voltages: <ul style="list-style-type: none"> VREGIN (USB) = 5.0 V VDD = 3.3 V Temp = 25°C	FSYS = 120 MHz FBUS = 60 MHz External crystal = 8 MHz	150 kHz–50 MHz	14	dBuV	1, 2, 3
			50 MHz–150 MHz	23		
			150 MHz–500 MHz	23		
			500 MHz–1000 MHz	9		
			IEC level	L		4

1. Measurements were made per IEC 61967-2 while the device was running typical application code.
2. Measurements were performed on the 64LQFP device, MK22FN512VLH12 .

General

- The reported emission level is the value of the maximum measured emission, rounded up to the next whole number, from among the measured orientations in each frequency range.
- IEC Level Maximums: $M \leq 18\text{dBmV}$, $L \leq 24\text{dBmV}$, $K \leq 30\text{dBmV}$, $I \leq 36\text{dBmV}$, $H \leq 42\text{dBmV}$.

2.2.7 Designing with radiated emissions in mind

To find application notes that provide guidance on designing your system to minimize interference from radiated emissions:

- Go to nxp.com
- Perform a keyword search for “EMC design.”

2.2.8 Capacitance attributes

Table 9. Capacitance attributes

Symbol	Description	Min.	Max.	Unit
C_{IN_A}	Input capacitance: analog pins	—	7	pF
C_{IN_D}	Input capacitance: digital pins	—	7	pF

2.3 Switching specifications

2.3.1 Device clock specifications

Table 10. Device clock specifications

Symbol	Description	Min.	Max.	Unit	Notes
High Speed run mode					
f_{SYS}	System and core clock	—	120	MHz	
f_{BUS}	Bus clock	—	60	MHz	
Normal run mode (and High Speed run mode unless otherwise specified above)					
f_{SYS}	System and core clock	—	80	MHz	
f_{SYS_USB}	System and core clock when Full Speed USB in operation	20	—	MHz	
f_{BUS}	Bus clock	—	50	MHz	
FB_CLK	FlexBus clock	—	30	MHz	
f_{FLASH}	Flash clock	—	26.67	MHz	
f_{LPTMR}	LPTMR clock	—	25	MHz	
VLPR mode ¹					

Table continues on the next page...

Table 10. Device clock specifications (continued)

Symbol	Description	Min.	Max.	Unit	Notes
f_{SYS}	System and core clock	—	4	MHz	
f_{BUS}	Bus clock	—	4	MHz	
FB_CLK	FlexBus clock	—	4	MHz	
f_{FLASH}	Flash clock	—	1	MHz	
f_{ERCLK}	External reference clock	—	16	MHz	
f_{LPTMR_pin}	LPTMR clock	—	25	MHz	
f_{LPTMR_ERCLK}	LPTMR external reference clock	—	16	MHz	
f_{I2S_MCLK}	I2S master clock	—	12.5	MHz	
f_{I2S_BCLK}	I2S bit clock	—	4	MHz	

1. The frequency limitations in VLPR mode here override any frequency specification listed in the timing specification for any other module.

2.3.2 General switching specifications

These general purpose specifications apply to all signals configured for GPIO, UART, and timers.

Table 11. General switching specifications

Symbol	Description	Min.	Max.	Unit	Notes
	GPIO pin interrupt pulse width (digital glitch filter disabled) — Synchronous path	1.5	—	Bus clock cycles	1, 2
	External RESET and NMI pin interrupt pulse width — Asynchronous path	100	—	ns	3
	GPIO pin interrupt pulse width (digital glitch filter disabled, passive filter disabled) — Asynchronous path	50	—	ns	4
	Mode select ($\overline{EZP_CS}$) hold time after reset deassertion	2	—	Bus clock cycles	
	Port rise and fall time <ul style="list-style-type: none"> • Slew disabled <ul style="list-style-type: none"> • $1.71 \leq V_{DD} \leq 2.7V$ • $2.7 \leq V_{DD} \leq 3.6V$ • Slew enabled <ul style="list-style-type: none"> • $1.71 \leq V_{DD} \leq 2.7V$ • $2.7 \leq V_{DD} \leq 3.6V$ 	—	—	ns	5

1. This is the minimum pulse width that is guaranteed to pass through the pin synchronization circuitry. Shorter pulses may or may not be recognized. In Stop, VLPS, LLS, and VLLSx modes, the synchronizer is bypassed so shorter pulses can be recognized in that case.

General

- The greater of synchronous and asynchronous timing must be met.
- These pins have a passive filter enabled on the inputs. This is the shortest pulse width that is guaranteed to be recognized.
- These pins do not have a passive filter on the inputs. This is the shortest pulse width that is guaranteed to be recognized.
- 25 pF load

2.4 Thermal specifications

2.4.1 Thermal operating requirements

Table 12. Thermal operating requirements

Symbol	Description	Min.	Max.	Unit	Notes
T _J	Die junction temperature	-40	125	°C	
T _A	Ambient temperature	-40	105	°C	1

- Maximum T_A can be exceeded only if the user ensures that T_J does not exceed maximum T_J. The simplest method to determine T_J is: $T_J = T_A + R_{\theta JA} \times \text{chip power dissipation}$.

2.4.2 Thermal attributes

Board type	Symbol	Description	121 XFBGA	100 LQFP	64 LQFP	64 MAPB GA	Unit	Notes
Single-layer (1s)	R _{θJA}	Thermal resistance, junction to ambient (natural convection)	44.4	61	67	95.7	°C/W	1
Four-layer (2s2p)	R _{θJA}	Thermal resistance, junction to ambient (natural convection)	27.0	48	48	48.8	°C/W	2
Single-layer (1s)	R _{θJMA}	Thermal resistance, junction to ambient (200 ft./min. air speed)	37.2	51	55	74.4	°C/W	3
Four-layer (2s2p)	R _{θJMA}	Thermal resistance, junction to ambient (200 ft./min. air speed)	23.7	42	42	44.0	°C/W	3
—	R _{θJB}	Thermal resistance, junction to board	23.5	34	31	30.3	°C/W	4
—	R _{θJC}	Thermal resistance, junction to case	17.4	16	16	28.0	°C/W	5
—	Ψ _{JT}	Thermal characterization parameter, junction to package top outside	0.2	3	3	1.0	°C/W	6

Board type	Symbol	Description	121 XFBGA	100 LQFP	64 LQFP	64 MAPB GA	Unit	Notes
		center (natural convection)						

1. Determined according to JEDEC Standard JESD51-2, *Integrated Circuits Thermal Test Method Environmental Conditions—Natural Convection (Still Air)* with the single layer board horizontal. Board meets JESD51-9 specification.
2. Determined according to JEDEC Standard JESD51-2, *Integrated Circuits Thermal Test Method Environmental Conditions—Natural Convection (Still Air)*.
3. Determined according to JEDEC Standard JESD51-6, *Integrated Circuits Thermal Test Method Environmental Conditions—Forced Convection (Moving Air)* with the board horizontal.
4. Determined according to JEDEC Standard JESD51-8, *Integrated Circuit Thermal Test Method Environmental Conditions—Junction-to-Board*.
5. Thermal resistance between the die and the case top surface as measured by the cold plate method (MIL SPEC-883 Method 1012.1).
6. Thermal characterization parameter indicating the temperature difference between package top and the junction temperature per JEDEC JESD51-2.

2.4.3 Thermal attributes for 88 QFN

Board type	Symbol	Description	88 QFN	Unit	Notes
Single-layer (1s)	$R_{\theta JA}$	Thermal resistance, junction to ambient (natural convection)	55	°C/W	1, 2
Four-layer (2s2p)	$R_{\theta JA}$	Thermal resistance, junction to ambient (natural convection)	20	°C/W	1, 2
Single-layer (1s)	$R_{\theta JMA}$	Thermal resistance, junction to ambient (200 ft./min. air speed)	50	°C/W	1, 3
Four-layer (2s2p)	$R_{\theta JMA}$	Thermal resistance, junction to ambient (200 ft./min. air speed)	15	°C/W	1,3
—	$R_{\theta JB}$	Thermal resistance, junction to board	7	°C/W	4
—	$R_{\theta JC}$	Thermal resistance, junction to case	1	°C/W	5
—	Ψ_{JT}	Thermal characterization	1	°C/W	6

Peripheral operating requirements and behaviors

Board type	Symbol	Description	88 QFN	Unit	Notes
		parameter, junction to package top outside center (natural convection)			

1. Junction temperature is a function of die size, on-chip power dissipation, package thermal resistance, mounting site (board) temperature, ambient temperature, air flow, power dissipation of other components on the board, and board thermal resistance.
2. Per JEDEC JESD51-2 with natural convection for horizontally oriented board. Board meets JESD51-9 specification for 1s or 2s2p board, respectively.
3. Per JEDEC JESD51-6 with forced convection for horizontally oriented board. Board meets JESD51-9 specification for 1s or 2s2p board, respectively.
4. Thermal resistance between the die and the printed circuit board per JEDEC JESD51-8. Board temperature is measured on the top surface of the board near the package.
5. Thermal resistance between the die and the solder pad on the bottom of the package. Interface resistance is ignored.
6. Thermal characterization parameter indicating the temperature difference between package top and the junction temperature per JEDEC JESD51-2. When Greek letters are not available, the thermal characterization parameter is written as Psi-JT.

3 Peripheral operating requirements and behaviors

3.1 Core modules

3.1.1 SWD electricals

Table 13. SWD full voltage range electricals

Symbol	Description	Min.	Max.	Unit
	Operating voltage	1.71	3.6	V
S1	SWD_CLK frequency of operation <ul style="list-style-type: none"> • Serial wire debug 	0	33	MHz
S2	SWD_CLK cycle period	1/S1	—	ns
S3	SWD_CLK clock pulse width <ul style="list-style-type: none"> • Serial wire debug 	15	—	ns
S4	SWD_CLK rise and fall times	—	3	ns
S9	SWD_DIO input data setup time to SWD_CLK rise	8	—	ns
S10	SWD_DIO input data hold time after SWD_CLK rise	1.4	—	ns
S11	SWD_CLK high to SWD_DIO data valid	—	25	ns
S12	SWD_CLK high to SWD_DIO high-Z	5	—	ns

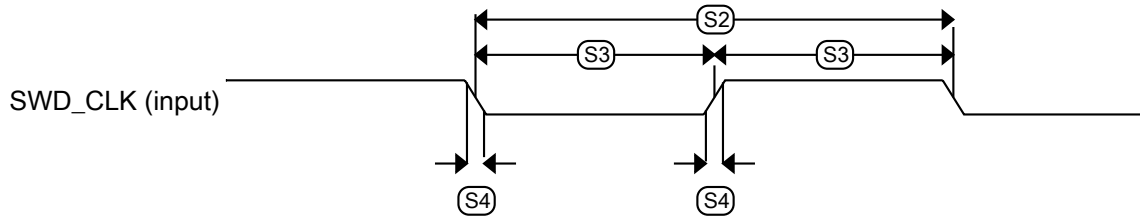

Figure 5. Serial wire clock input timing

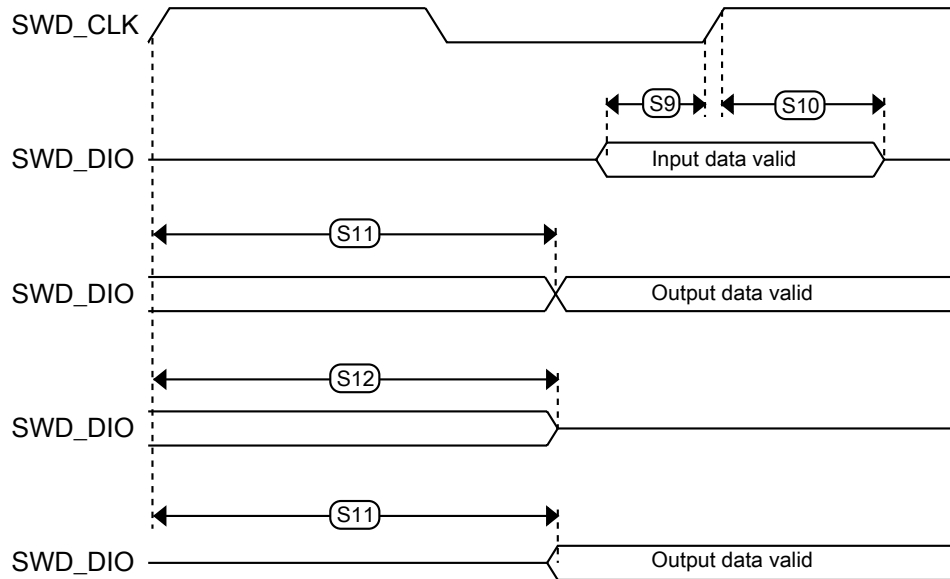

Figure 6. Serial wire data timing

3.1.2 JTAG electricals

Table 14. JTAG limited voltage range electricals

Symbol	Description	Min.	Max.	Unit
	Operating voltage	2.7	3.6	V
J1	TCLK frequency of operation <ul style="list-style-type: none"> • Boundary Scan • JTAG and CJTAG 	0 0	10 20	MHz
J2	TCLK cycle period	1/J1	—	ns
J3	TCLK clock pulse width	50	—	ns

Table continues on the next page...

Table 14. JTAG limited voltage range electricals (continued)

Symbol	Description	Min.	Max.	Unit
	<ul style="list-style-type: none"> Boundary Scan JTAG and CJTAG 	25	—	ns
J4	TCLK rise and fall times	—	3	ns
J5	Boundary scan input data setup time to TCLK rise	20	—	ns
J6	Boundary scan input data hold time after TCLK rise	1	—	ns
J7	TCLK low to boundary scan output data valid	—	25	ns
J8	TCLK low to boundary scan output high-Z	—	25	ns
J9	TMS, TDI input data setup time to TCLK rise	8	—	ns
J10	TMS, TDI input data hold time after TCLK rise	1	—	ns
J11	TCLK low to TDO data valid	—	19	ns
J12	TCLK low to TDO high-Z	—	19	ns
J13	$\overline{\text{TRST}}$ assert time	100	—	ns
J14	$\overline{\text{TRST}}$ setup time (negation) to TCLK high	8	—	ns

Table 15. JTAG full voltage range electricals

Symbol	Description	Min.	Max.	Unit
	Operating voltage	1.71	3.6	V
J1	TCLK frequency of operation			MHz
	<ul style="list-style-type: none"> Boundary Scan JTAG and CJTAG 	0	10	
		0	15	
J2	TCLK cycle period	1/J1	—	ns
J3	TCLK clock pulse width			
	<ul style="list-style-type: none"> Boundary Scan JTAG and CJTAG 	50	—	ns
		33	—	ns
J4	TCLK rise and fall times	—	3	ns
J5	Boundary scan input data setup time to TCLK rise	20	—	ns
J6	Boundary scan input data hold time after TCLK rise	1.4	—	ns
J7	TCLK low to boundary scan output data valid	—	27	ns
J8	TCLK low to boundary scan output high-Z	—	27	ns
J9	TMS, TDI input data setup time to TCLK rise	8	—	ns
J10	TMS, TDI input data hold time after TCLK rise	1.4	—	ns
J11	TCLK low to TDO data valid	—	26.2	ns
J12	TCLK low to TDO high-Z	—	26.2	ns
J13	$\overline{\text{TRST}}$ assert time	100	—	ns
J14	$\overline{\text{TRST}}$ setup time (negation) to TCLK high	8	—	ns

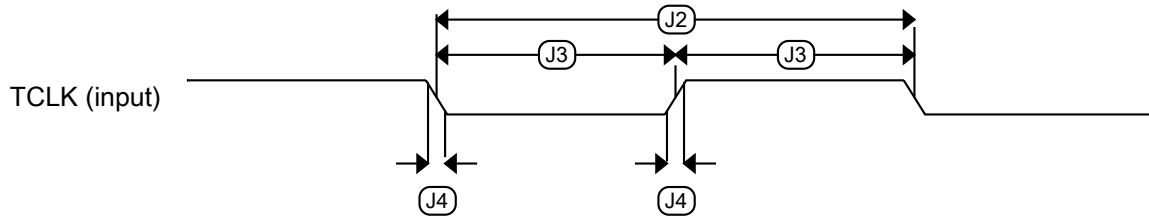

Figure 7. Test clock input timing

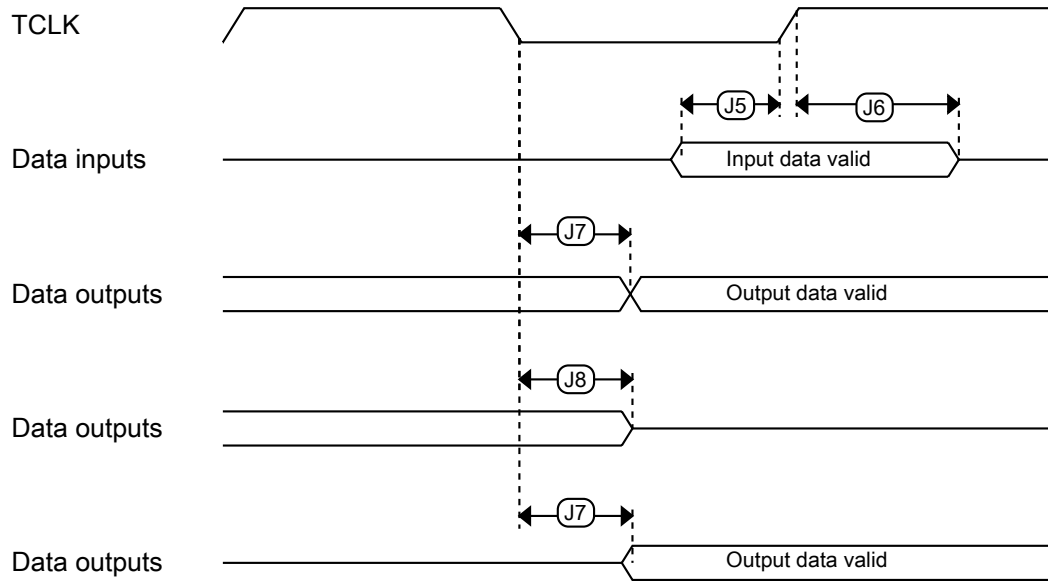

Figure 8. Boundary scan (JTAG) timing

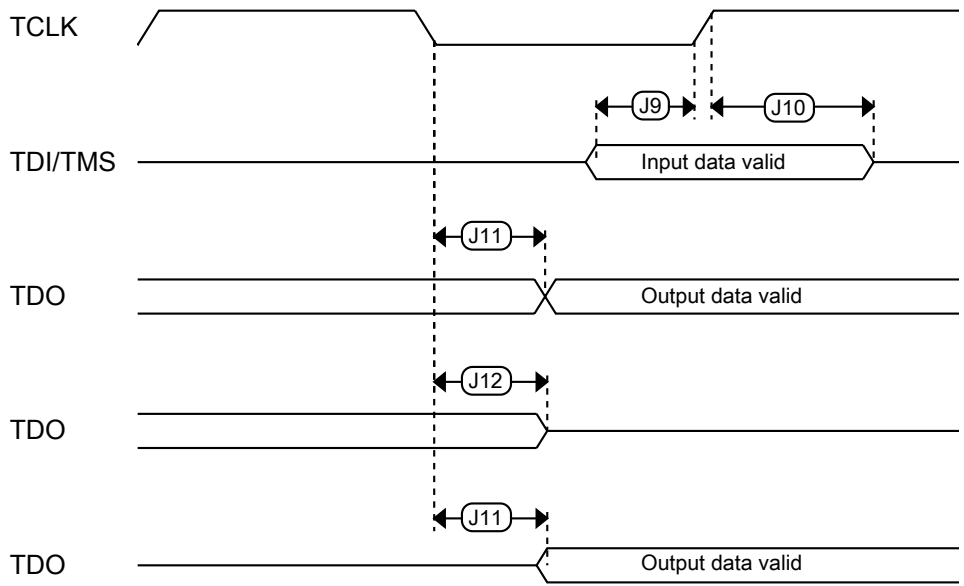

Figure 9. Test Access Port timing

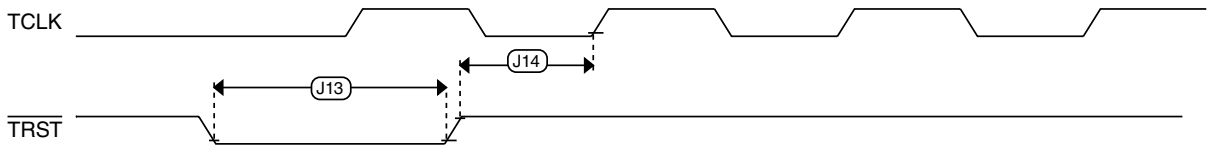

Figure 10. TRST timing

3.2 System modules

There are no specifications necessary for the device's system modules.

3.3 Clock modules

3.3.1 MCG specifications

Table 16. MCG specifications

Symbol	Description	Min.	Typ.	Max.	Unit	Notes	
$f_{\text{ints_ft}}$	Internal reference frequency (slow clock) — factory trimmed at nominal VDD and 25 °C	—	32.768	—	kHz		
$\Delta f_{\text{ints_t}}$	Total deviation of internal reference frequency (slow clock) over voltage and temperature	—	+0.5/-0.7	± 2	%		
$f_{\text{ints_t}}$	Internal reference frequency (slow clock) — user trimmed	31.25	—	39.0625	kHz		
$\Delta f_{\text{dco_res_t}}$	Resolution of trimmed average DCO output frequency at fixed voltage and temperature — using SCTRIM and SCFTRIM	—	± 0.3	± 0.6	% f_{dco}	1	
$\Delta f_{\text{dco_t}}$	Total deviation of trimmed average DCO output frequency over voltage and temperature	—	+0.5/-0.7	± 2	% f_{dco}	1, 2	
$\Delta f_{\text{dco_t}}$	Total deviation of trimmed average DCO output frequency over fixed voltage and temperature range of 0–70°C	—	± 0.3	± 1.5	% f_{dco}	1	
$f_{\text{intf_ft}}$	Internal reference frequency (fast clock) — factory trimmed at nominal VDD and 25°C	—	4	—	MHz		
$\Delta f_{\text{intf_ft}}$	Frequency deviation of internal reference clock (fast clock) over temperature and voltage — factory trimmed at nominal VDD and 25 °C	—	+1/-2	± 5	% $f_{\text{intf_ft}}$		
$f_{\text{intf_t}}$	Internal reference frequency (fast clock) — user trimmed at nominal VDD and 25 °C	3	—	5	MHz		
$f_{\text{loc_low}}$	Loss of external clock minimum frequency — RANGE = 00	$(3/5) \times f_{\text{ints_t}}$	—	—	kHz		
$f_{\text{loc_high}}$	Loss of external clock minimum frequency — RANGE = 01, 10, or 11	$(16/5) \times f_{\text{ints_t}}$	—	—	kHz		
FLL							
$f_{\text{fill_ref}}$	FLL reference frequency range	31.25	—	39.0625	kHz		
f_{dco}	DCO output frequency range	Low range (DRS=00) $640 \times f_{\text{fill_ref}}$	20	20.97	25	MHz	3, 4
		Mid range (DRS=01) $1280 \times f_{\text{fill_ref}}$	40	41.94	50	MHz	
		Mid-high range (DRS=10) $1920 \times f_{\text{fill_ref}}$	60	62.91	75	MHz	
		High range (DRS=11) $2560 \times f_{\text{fill_ref}}$	80	83.89	100	MHz	
$f_{\text{dco_t_DMX3}_2}$	DCO output frequency	Low range (DRS=00) $732 \times f_{\text{fill_ref}}$	—	23.99	—	MHz	5, 6
		Mid range (DRS=01) $1464 \times f_{\text{fill_ref}}$	—	47.97	—	MHz	
		Mid-high range (DRS=10)	—	71.99	—	MHz	

Table continues on the next page...

Table 16. MCG specifications (continued)

Symbol	Description	Min.	Typ.	Max.	Unit	Notes
J_{cyc_fll}	FLL period jitter <ul style="list-style-type: none"> $f_{VCO} = 48$ MHz $f_{VCO} = 98$ MHz 	—	—	—	ps	
$t_{fll_acquire}$	FLL target frequency acquisition time	—	—	1	ms	7
PLL						
f_{vco}	VCO operating frequency	48.0	—	120	MHz	
I_{pll}	PLL operating current <ul style="list-style-type: none"> PLL @ 96 MHz ($f_{osc_hi_1} = 8$ MHz, $f_{pll_ref} = 2$ MHz, VDIV multiplier = 48) 	—	1060	—	μ A	8
I_{pll}	PLL operating current <ul style="list-style-type: none"> PLL @ 48 MHz ($f_{osc_hi_1} = 8$ MHz, $f_{pll_ref} = 2$ MHz, VDIV multiplier = 24) 	—	600	—	μ A	8
f_{pll_ref}	PLL reference frequency range	2.0	—	4.0	MHz	
J_{cyc_pll}	PLL period jitter (RMS) <ul style="list-style-type: none"> $f_{vco} = 48$ MHz $f_{vco} = 100$ MHz 	—	120	—	ps	9
J_{acc_pll}	PLL accumulated jitter over 1 μ s (RMS) <ul style="list-style-type: none"> $f_{vco} = 48$ MHz $f_{vco} = 100$ MHz 	—	1350	—	ps	9
D_{lock}	Lock entry frequency tolerance	± 1.49	—	± 2.98	%	
D_{unl}	Lock exit frequency tolerance	± 4.47	—	± 5.97	%	
t_{pll_lock}	Lock detector detection time	—	—	$150 \times 10^{-6} + 1075(1/f_{pll_ref})$	s	10

1. This parameter is measured with the internal reference (slow clock) being used as a reference to the FLL (FEI clock mode).
2. $2.0\text{ V} \leq VDD \leq 3.6\text{ V}$.
3. These typical values listed are with the slow internal reference clock (FEI) using factory trim and DMX32=0.
4. The resulting system clock frequencies should not exceed their maximum specified values. The DCO frequency deviation (Δf_{dco_t}) over voltage and temperature should be considered.
5. These typical values listed are with the slow internal reference clock (FEI) using factory trim and DMX32=1.
6. The resulting clock frequency must not exceed the maximum specified clock frequency of the device.
7. This specification applies to any time the FLL reference source or reference divider is changed, trim value is changed, DMX32 bit is changed, DRS bits are changed, or changing from FLL disabled (BLPE, BLPI) to FLL enabled (FEI, FEE, FBE, FBI). If a crystal/resonator is being used as the reference, this specification assumes it is already running.
8. Excludes any oscillator currents that are also consuming power while PLL is in operation.
9. This specification was obtained using a NXP developed PCB. PLL jitter is dependent on the noise characteristics of each PCB and results will vary.
10. This specification applies to any time the PLL VCO divider or reference divider is changed, or changing from PLL disabled (BLPE, BLPI) to PLL enabled (PBE, PEE). If a crystal/resonator is being used as the reference, this specification assumes it is already running.

3.3.2 IRC48M specifications

Table 17. IRC48M specifications

Symbol	Description	Min.	Typ.	Max.	Unit	Notes
V_{DD}	Supply voltage	1.71	—	3.6	V	
I_{DD48M}	Supply current	—	400	500	μ A	
f_{irc48m}	Internal reference frequency	—	48	—	MHz	
$\Delta f_{irc48m_ol_hv}$	Open loop total deviation of IRC48M frequency at high voltage ($V_{DD}=1.89V-3.6V$) over $0^{\circ}C$ to $70^{\circ}C$ Regulator enable ($USB_CLK_RECOVER_IRC_EN[REG_EN]=1$)	—	± 0.2	± 0.5	$\%f_{irc48m}$	1
$\Delta f_{irc48m_ol_hv}$	Open loop total deviation of IRC48M frequency at high voltage ($V_{DD}=1.89V-3.6V$) over full temperature Regulator enable ($USB_CLK_RECOVER_IRC_EN[REG_EN]=1$)	—	± 0.4	± 1.0	$\%f_{irc48m}$	1
$\Delta f_{irc48m_ol_lv}$	Open loop total deviation of IRC48M frequency at low voltage ($V_{DD}=1.71V-1.89V$) over full temperature Regulator disable ($USB_CLK_RECOVER_IRC_EN[REG_EN]=0$) Regulator enable ($USB_CLK_RECOVER_IRC_EN[REG_EN]=1$)	—	± 0.4 ± 0.5	± 1.0 ± 1.5	$\%f_{irc48m}$	1
Δf_{irc48m_cl}	Closed loop total deviation of IRC48M frequency over voltage and temperature	—	—	± 0.1	$\%f_{host}$	2
J_{cyc_irc48m}	Period Jitter (RMS)	—	35	150	ps	
$t_{irc48mst}$	Startup time	—	2	3	μ s	3

- The maximum value represents characterized results equivalent to the mean plus or minus three times the standard deviation (mean ± 3 sigma).
- Closed loop operation of the IRC48M is only feasible for USB device operation; it is not usable for USB host operation. It is enabled by configuring for USB Device, selecting IRC48M as USB clock source, and enabling the clock recover function ($USB_CLK_RECOVER_IRC_CTRL[CLOCK_RECOVER_EN]=1$, $USB_CLK_RECOVER_IRC_EN[IRC_EN]=1$).
- IRC48M startup time is defined as the time between clock enablement and clock availability for system use. Enable the clock by one of the following settings:
 - $USB_CLK_RECOVER_IRC_EN[IRC_EN]=1$ or
 - MCG operating in an external clocking mode and $MCG_C7[OSCSSEL]=10$ or $MCG_C5[PLLCLKEN0]=1$, or
 - $SIM_SOPT2[PLLFLSEL]=11$

3.3.3 Oscillator electrical specifications

3.3.3.1 Oscillator DC electrical specifications

Table 18. Oscillator DC electrical specifications

Symbol	Description	Min.	Typ.	Max.	Unit	Notes
V_{DD}	Supply voltage	1.71	—	3.6	V	
I_{DDOSC}	Supply current — low-power mode (HGO=0) <ul style="list-style-type: none"> 32 kHz 4 MHz 8 MHz (RANGE=01) 16 MHz 24 MHz 32 MHz 	—	500	—	nA	1
		—	200	—	μ A	
		—	300	—	μ A	
		—	950	—	μ A	
		—	1.2	—	mA	
		—	1.5	—	mA	
I_{DDOSC}	Supply current — high-gain mode (HGO=1) <ul style="list-style-type: none"> 32 kHz 4 MHz 8 MHz (RANGE=01) 16 MHz 24 MHz 32 MHz 	—	25	—	μ A	1
		—	400	—	μ A	
		—	500	—	μ A	
		—	2.5	—	mA	
		—	3	—	mA	
		—	4	—	mA	
C_x	EXTAL load capacitance	—	—	—		2, 3
C_y	XTAL load capacitance	—	—	—		2, 3
R_F	Feedback resistor — low-frequency, low-power mode (HGO=0)	—	—	—	M Ω	2, 4
	Feedback resistor — low-frequency, high-gain mode (HGO=1)	—	10	—	M Ω	
	Feedback resistor — high-frequency, low-power mode (HGO=0)	—	—	—	M Ω	
	Feedback resistor — high-frequency, high-gain mode (HGO=1)	—	1	—	M Ω	
R_S	Series resistor — low-frequency, low-power mode (HGO=0)	—	—	—	k Ω	
	Series resistor — low-frequency, high-gain mode (HGO=1)	—	200	—	k Ω	
	Series resistor — high-frequency, low-power mode (HGO=0)	—	—	—	k Ω	
	Series resistor — high-frequency, high-gain mode (HGO=1)	—	0	—	k Ω	
V_{pp}^5	Peak-to-peak amplitude of oscillation (oscillator mode) — low-frequency, low-power mode (HGO=0)	—	0.6	—	V	

Table continues on the next page...

Table 18. Oscillator DC electrical specifications (continued)

Symbol	Description	Min.	Typ.	Max.	Unit	Notes
	Peak-to-peak amplitude of oscillation (oscillator mode) — low-frequency, high-gain mode (HGO=1)	—	V _{DD}	—	V	
	Peak-to-peak amplitude of oscillation (oscillator mode) — high-frequency, low-power mode (HGO=0)	—	0.6	—	V	
	Peak-to-peak amplitude of oscillation (oscillator mode) — high-frequency, high-gain mode (HGO=1)	—	V _{DD}	—	V	

1. V_{DD}=3.3 V, Temperature =25 °C
2. See crystal or resonator manufacturer's recommendation.
3. C_x and C_y can be provided by using either integrated capacitors or external components.
4. When low-power mode is selected, R_F is integrated and must not be attached externally.
5. The EXTAL and XTAL pins should only be connected to required oscillator components and must not be connected to any other device.

3.3.3.2 Oscillator frequency specifications

Table 19. Oscillator frequency specifications

Symbol	Description	Min.	Typ.	Max.	Unit	Notes
f _{osc_lo}	Oscillator crystal or resonator frequency — low-frequency mode (MCG_C2[RANGE]=00)	32	—	40	kHz	
f _{osc_hi_1}	Oscillator crystal or resonator frequency — high-frequency mode (low range) (MCG_C2[RANGE]=01)	3	—	8	MHz	
f _{osc_hi_2}	Oscillator crystal or resonator frequency — high frequency mode (high range) (MCG_C2[RANGE]=1x)	8	—	32	MHz	
f _{ec_extal}	Input clock frequency (external clock mode)	—	—	50	MHz	1, 2
t _{dc_extal}	Input clock duty cycle (external clock mode)	40	50	60	%	
t _{cst}	Crystal startup time — 32 kHz low-frequency, low-power mode (HGO=0)	—	750	—	ms	3, 4
	Crystal startup time — 32 kHz low-frequency, high-gain mode (HGO=1)	—	250	—	ms	
	Crystal startup time — 8 MHz high-frequency (MCG_C2[RANGE]=01), low-power mode (HGO=0)	—	0.6	—	ms	
	Crystal startup time — 8 MHz high-frequency (MCG_C2[RANGE]=01), high-gain mode (HGO=1)	—	1	—	ms	

1. Other frequency limits may apply when external clock is being used as a reference for the FLL or PLL.
2. When transitioning from FEI or FBI to FBE mode, restrict the frequency of the input clock so that, when it is divided by FRDIV, it remains within the limits of the DCO input clock frequency.
3. Proper PC board layout procedures must be followed to achieve specifications.

Peripheral operating requirements and behaviors

- Crystal startup time is defined as the time between the oscillator being enabled and the OSCINIT bit in the MCG_S register being set.

3.3.4 32 kHz oscillator electrical characteristics

3.3.4.1 32 kHz oscillator DC electrical specifications

Table 20. 32 kHz oscillator DC electrical specifications

Symbol	Description	Min.	Typ.	Max.	Unit
V_{BAT}	Supply voltage	1.71	—	3.6	V
R_F	Internal feedback resistor	—	100	—	$M\Omega$
C_{para}	Parasitical capacitance of EXTAL32 and XTAL32	—	5	7	pF
V_{pp}^1	Peak-to-peak amplitude of oscillation	—	0.6	—	V

- When a crystal is being used with the 32 kHz oscillator, the EXTAL32 and XTAL32 pins should only be connected to required oscillator components and must not be connected to any other devices.

3.3.4.2 32 kHz oscillator frequency specifications

Table 21. 32 kHz oscillator frequency specifications

Symbol	Description	Min.	Typ.	Max.	Unit	Notes
f_{osc_lo}	Oscillator crystal	—	32.768	—	kHz	
t_{start}	Crystal start-up time	—	1000	—	ms	1
$f_{ec_extal32}$	Externally provided input clock frequency	—	32.768	—	kHz	2
$V_{ec_extal32}$	Externally provided input clock amplitude	700	—	V_{BAT}	mV	2, 3

- Proper PC board layout procedures must be followed to achieve specifications.
- This specification is for an externally supplied clock driven to EXTAL32 and does not apply to any other clock input. The oscillator remains enabled and XTAL32 must be left unconnected.
- The parameter specified is a peak-to-peak value and V_{IH} and V_{IL} specifications do not apply. The voltage of the applied clock must be within the range of V_{SS} to V_{BAT} .

3.4 Memories and memory interfaces

3.4.1 Flash electrical specifications

This section describes the electrical characteristics of the flash memory module.

3.4.1.1 Flash timing specifications — program and erase

The following specifications represent the amount of time the internal charge pumps are active and do not include command overhead.

Table 22. NVM program/erase timing specifications

Symbol	Description	Min.	Typ.	Max.	Unit	Notes
t_{hvpgm4}	Longword Program high-voltage time	—	7.5	18	μ s	—
$t_{hversscr}$	Sector Erase high-voltage time	—	13	113	ms	1
$t_{hversblk256k}$	Erase Block high-voltage time for 256 KB	—	104	904	ms	1

1. Maximum time based on expectations at cycling end-of-life.

3.4.1.2 Flash timing specifications — commands

Table 23. Flash command timing specifications

Symbol	Description	Min.	Typ.	Max.	Unit	Notes
$t_{rd1blk256k}$	Read 1s Block execution time • 256 KB program flash	—	—	1.7	ms	1
$t_{rd1sec2k}$	Read 1s Section execution time (flash sector)	—	—	60	μ s	1
t_{pgmchk}	Program Check execution time	—	—	45	μ s	1
t_{rdsrc}	Read Resource execution time	—	—	30	μ s	1
t_{pgm4}	Program Longword execution time	—	65	145	μ s	—
$t_{ersblk256k}$	Erase Flash Block execution time • 256 KB program flash	—	250	1500	ms	2
t_{ersscr}	Erase Flash Sector execution time	—	14	114	ms	2
t_{rd1all}	Read 1s All Blocks execution time	—	—	1.8	ms	1
t_{rdonce}	Read Once execution time	—	—	30	μ s	1
$t_{pgmonce}$	Program Once execution time	—	100	—	μ s	—
t_{ersall}	Erase All Blocks execution time	—	500	3000	ms	2
t_{vfykey}	Verify Backdoor Access Key execution time	—	—	30	μ s	1

1. Assumes 25 MHz flash clock frequency.
2. Maximum times for erase parameters based on expectations at cycling end-of-life.

3.4.1.3 Flash high voltage current behaviors

Table 24. Flash high voltage current behaviors

Symbol	Description	Min.	Typ.	Max.	Unit
I_{DD_PGM}	Average current adder during high voltage flash programming operation	—	2.5	6.0	mA

Table continues on the next page...

Table 24. Flash high voltage current behaviors (continued)

Symbol	Description	Min.	Typ.	Max.	Unit
I _{DD_ERS}	Average current adder during high voltage flash erase operation	—	1.5	4.0	mA

3.4.1.4 Reliability specifications

Table 25. NVM reliability specifications

Symbol	Description	Min.	Typ. ¹	Max.	Unit	Notes
Program Flash						
t _{nvmretp10k}	Data retention after up to 10 K cycles	5	50	—	years	—
t _{nvmretp1k}	Data retention after up to 1 K cycles	20	100	—	years	—
n _{nvmcycp}	Cycling endurance	10 K	50 K	—	cycles	2

1. Typical data retention values are based on measured response accelerated at high temperature and derated to a constant 25 °C use profile. Engineering Bulletin EB618 does not apply to this technology. Typical endurance defined in Engineering Bulletin EB619.
2. Cycling endurance represents number of program/erase cycles at $-40\text{ °C} \leq T_j \leq 125\text{ °C}$.

3.4.2 EzPort switching specifications

Table 26. EzPort switching specifications

Num	Description	Min.	Max.	Unit
	Operating voltage	1.71	3.6	V
EP1	EZP_CK frequency of operation (all commands except READ)	—	f _{sys} /2	MHz
EP1a	EZP_CK frequency of operation (READ command)	—	f _{sys} /8	MHz
EP2	$\overline{\text{EZP_CS}}$ negation to next $\overline{\text{EZP_CS}}$ assertion	2 x t _{EZP_CK}	—	ns
EP3	$\overline{\text{EZP_CS}}$ input valid to EZP_CK high (setup)	5	—	ns
EP4	EZP_CK high to $\overline{\text{EZP_CS}}$ input invalid (hold)	5	—	ns
EP5	EZP_D input valid to EZP_CK high (setup)	2	—	ns
EP6	EZP_CK high to EZP_D input invalid (hold)	5	—	ns
EP7	EZP_CK low to EZP_Q output valid	—	25	ns
EP8	EZP_CK low to EZP_Q output invalid (hold)	0	—	ns
EP9	$\overline{\text{EZP_CS}}$ negation to EZP_Q tri-state	—	12	ns

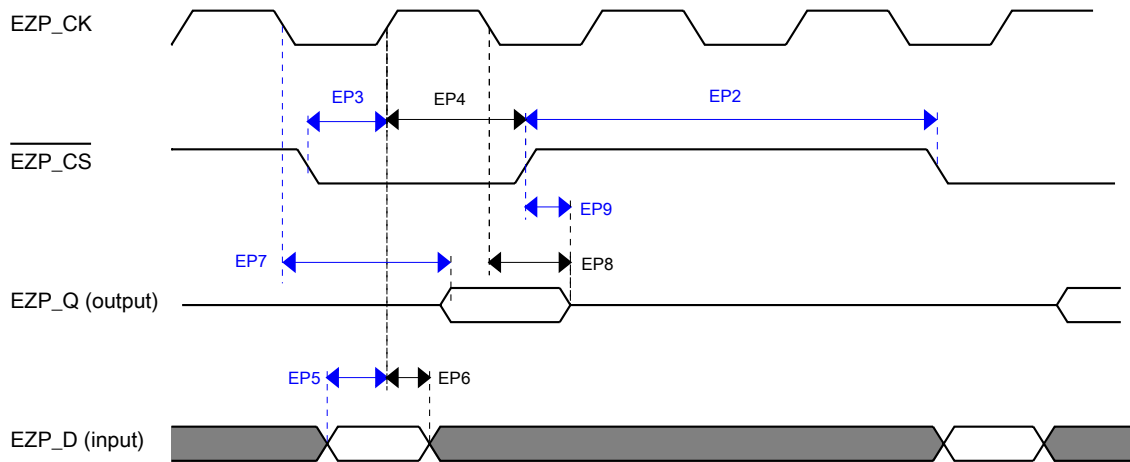

Figure 11. EzPort Timing Diagram

3.4.3 Flexbus switching specifications

All processor bus timings are synchronous; input setup/hold and output delay are given in respect to the rising edge of a reference clock, FB_CLK. The FB_CLK frequency may be the same as the internal system bus frequency or an integer divider of that frequency.

The following timing numbers indicate when data is latched or driven onto the external bus, relative to the Flexbus output clock (FB_CLK). All other timing relationships can be derived from these values.

Table 27. Flexbus limited voltage range switching specifications

Num	Description	Min.	Max.	Unit	Notes
	Operating voltage	2.7	3.6	V	
	Frequency of operation	—	30	MHz	
FB1	Clock period	33.3	—	ns	
FB2	Address, data, and control output valid	—	15	ns	
FB3	Address, data, and control output hold	0.5	—	ns	1
FB4	Data and $\overline{\text{FB_TA}}$ input setup	14.5	—	ns	
FB5	Data and $\overline{\text{FB_TA}}$ input hold	0.5	—	ns	2

1. Specification is valid for all FB_AD[31:0], $\overline{\text{FB_BE/BWE}n}$, $\overline{\text{FB_CS}n}$, $\overline{\text{FB_OE}}$, $\overline{\text{FB_R/W}}$, $\overline{\text{FB_TBST}}$, $\overline{\text{FB_TSIZ}}[1:0]$, $\overline{\text{FB_ALE}}$, and $\overline{\text{FB_TS}}$.

Peripheral operating requirements and behaviors

- Specification is valid for all FB_AD[31:0] and $\overline{\text{FB_TA}}$.

Table 28. Flexbus full voltage range switching specifications

Num	Description	Min.	Max.	Unit	Notes
	Operating voltage	1.71	3.6	V	
	Frequency of operation	—	30	MHz	
FB1	Clock period	33.3	—	ns	
FB2	Address, data, and control output valid	—	21.5	ns	
FB3	Address, data, and control output hold	-1.0	—	ns	1
FB4	Data and $\overline{\text{FB_TA}}$ input setup	20.0	—	ns	
FB5	Data and $\overline{\text{FB_TA}}$ input hold	0.5	—	ns	2

- Specification is valid for all FB_AD[31:0], $\overline{\text{FB_BE/BWEn}}$, $\overline{\text{FB_CSn}}$, $\overline{\text{FB_OE}}$, FB_R/W, FB_TBST, FB_TSIZ[1:0], FB_ALE, and FB_TS.
- Specification is valid for all FB_AD[31:0] and $\overline{\text{FB_TA}}$.

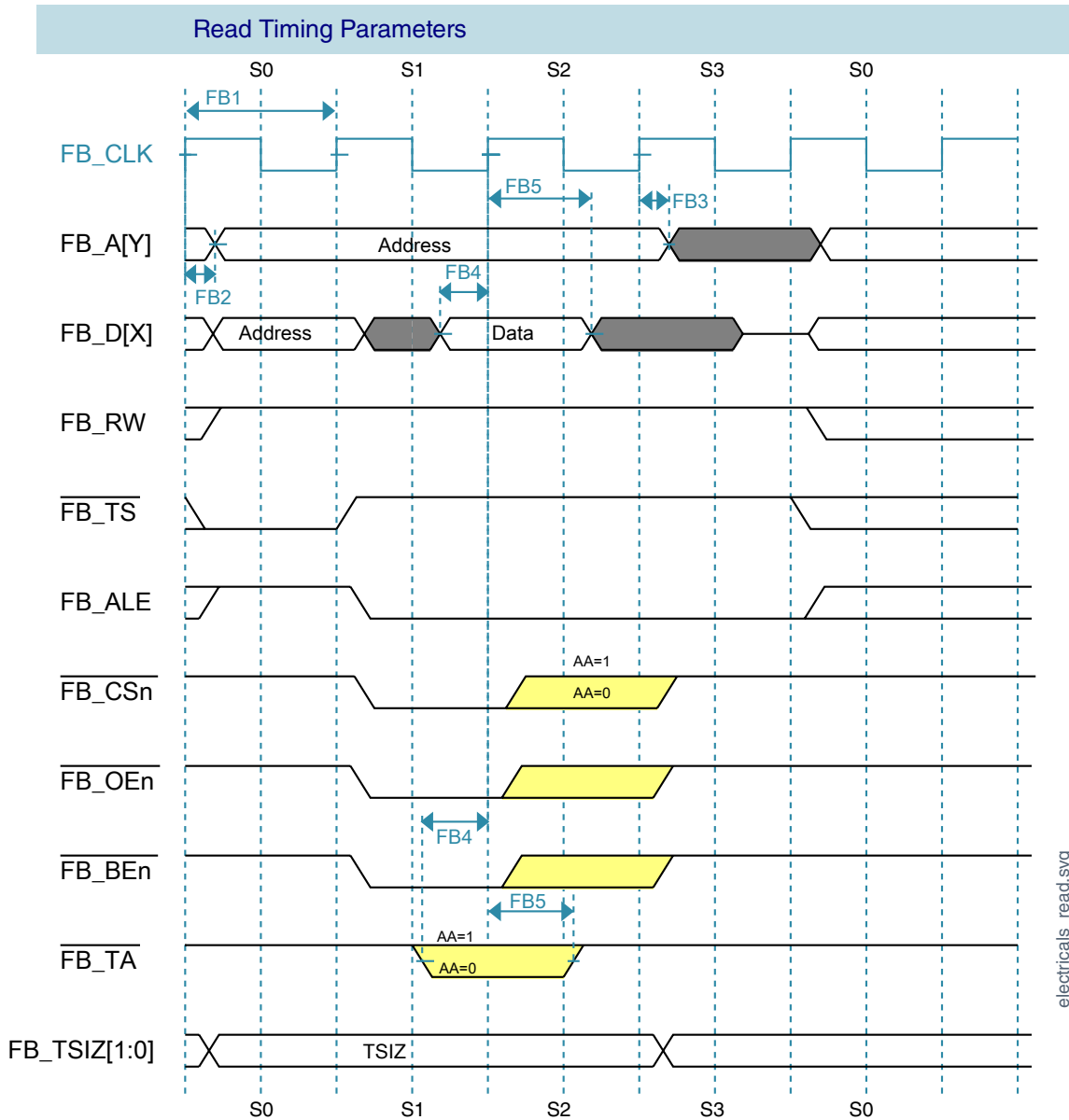

Figure 12. FlexBus read timing diagram

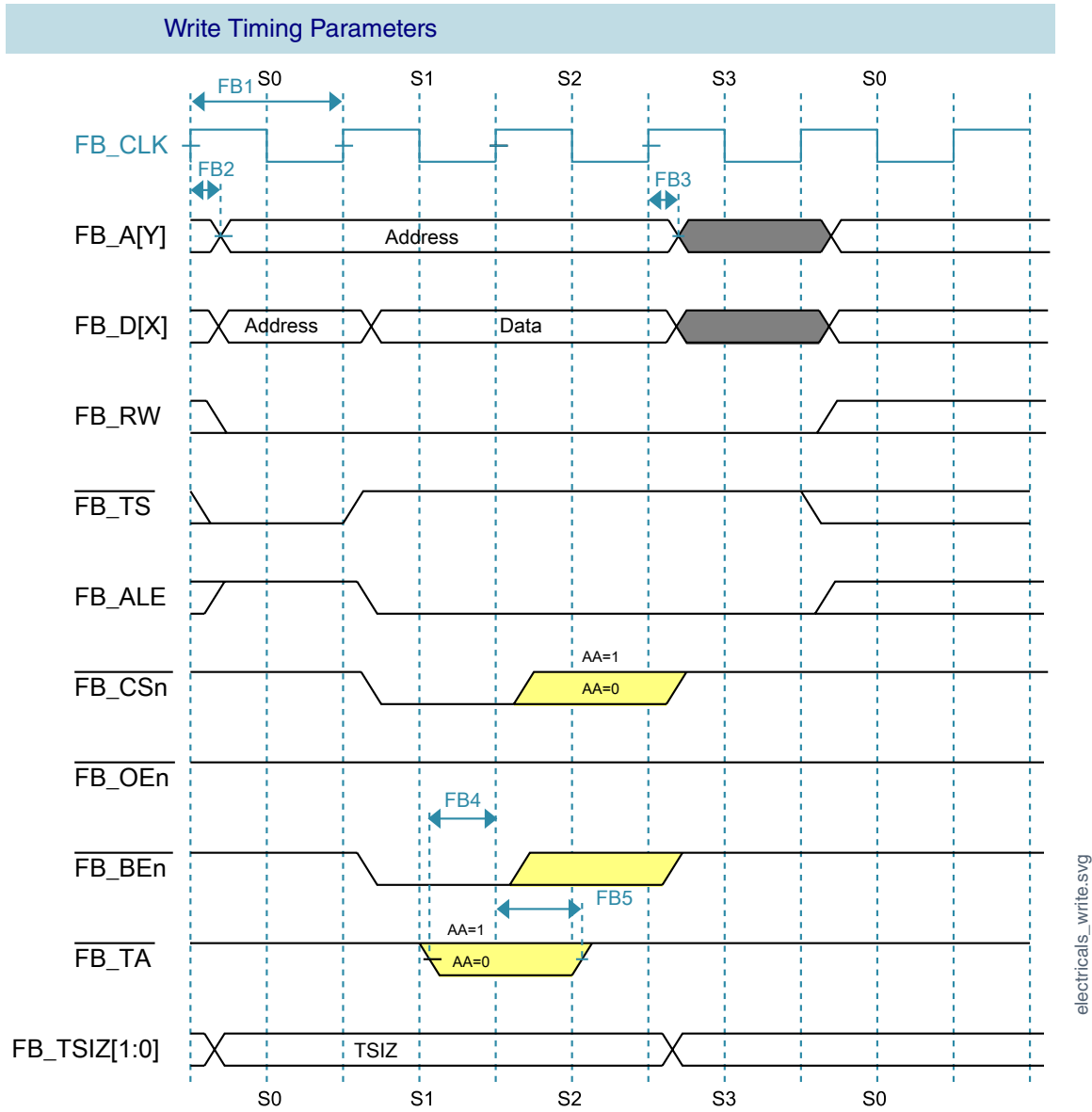

Figure 13. FlexBus write timing diagram

3.5 Security and integrity modules

There are no specifications necessary for the device's security and integrity modules.

3.6 Analog

3.6.1 ADC electrical specifications

The 16-bit accuracy specifications listed in [Table 29](#) and [Table 30](#) are achievable on the differential pins ADCx_DPx, ADCx_DMx.

All other ADC channels meet the 13-bit differential/12-bit single-ended accuracy specifications.

3.6.1.1 16-bit ADC operating conditions

Table 29. 16-bit ADC operating conditions

Symbol	Description	Conditions	Min.	Typ. ¹	Max.	Unit	Notes
V _{DDA}	Supply voltage	Absolute	1.71	—	3.6	V	
ΔV _{DDA}	Supply voltage	Delta to V _{DD} (V _{DD} – V _{DDA})	-100	0	+100	mV	2
ΔV _{SSA}	Ground voltage	Delta to V _{SS} (V _{SS} – V _{SSA})	-100	0	+100	mV	2
V _{REFH}	ADC reference voltage high		1.13	V _{DDA}	V _{DDA}	V	
V _{REFL}	ADC reference voltage low		V _{SSA}	V _{SSA}	V _{SSA}	V	
V _{ADIN}	Input voltage	<ul style="list-style-type: none"> 16-bit differential mode All other modes 	V _{REFL} V _{REFL}	— —	31/32 * V _{REFH} V _{REFH}	V	
C _{ADIN}	Input capacitance	<ul style="list-style-type: none"> 16-bit mode 8-bit / 10-bit / 12-bit modes 	— —	8 4	10 5	pF	
R _{ADIN}	Input series resistance		—	2	5	kΩ	
R _{AS}	Analog source resistance (external)	13-bit / 12-bit modes f _{ADCK} < 4 MHz	—	—	5	kΩ	3
f _{ADCK}	ADC conversion clock frequency	<13-bit mode	1.0	—	4.0	MHz	4
f _{ADCK}	ADC conversion clock frequency	16-bit mode	—	—	2.0	MHz	4
f _{ADCK}	ADC conversion clock frequency	<13-bit mode	1.0	—	8.0	MHz	5
f _{ADCK}	ADC conversion clock frequency	16-bit mode	2	—	4.0	MHz	5
f _{ADCK}	ADC conversion clock frequency	<13-bit mode	1.0	—	16.0	MHz	6
f _{ADCK}	ADC conversion clock frequency	16-bit mode	2	—	8.0	MHz	6

Table continues on the next page...

Table 29. 16-bit ADC operating conditions (continued)

Symbol	Description	Conditions	Min.	Typ. ¹	Max.	Unit	Notes
f _{ADCK}	ADC conversion clock frequency	<13-bit mode	1.0	—	24.0	MHz	7
f _{ADCK}	ADC conversion clock frequency	16-bit mode	2	—	12.0	MHz	7
C _{rate}	ADC conversion rate	≤ 13-bit modes No ADC hardware averaging Continuous conversions enabled, subsequent conversion time	20	—	1200	Ksps	8
C _{rate}	ADC conversion rate	16-bit mode No ADC hardware averaging Continuous conversions enabled, subsequent conversion time	37	—	461	Ksps	8

1. Typical values assume V_{DDA} = 3.0 V, Temp = 25 °C, f_{ADCK} = 1.0 MHz, unless otherwise stated. Typical values are for reference only, and are not tested in production.
2. DC potential difference.
3. This resistance is external to MCU. To achieve the best results, the analog source resistance must be kept as low as possible. The results in this data sheet were derived from a system that had < 8 Ω analog source resistance. The R_{AS}/C_{AS} time constant should be kept to < 1 ns.
4. To use the maximum ADC conversion clock frequency, CFG2[ADHSC] must be clear and CFG1[ADLPC] must be set.
5. To use the maximum ADC conversion clock frequency, both CFG2[ADHSC] and CFG1[ADLPC] must be set.
6. To use the maximum ADC conversion clock frequency, both CFG2[ADHSC] and CFG1[ADLPC] must be cleared.
7. To use the maximum ADC conversion clock frequency, both CFG2[ADHSC] must be set and CFG1[ADLPC] must be clear.
8. For guidelines and examples of conversion rate calculation, download the [ADC calculator tool](#).

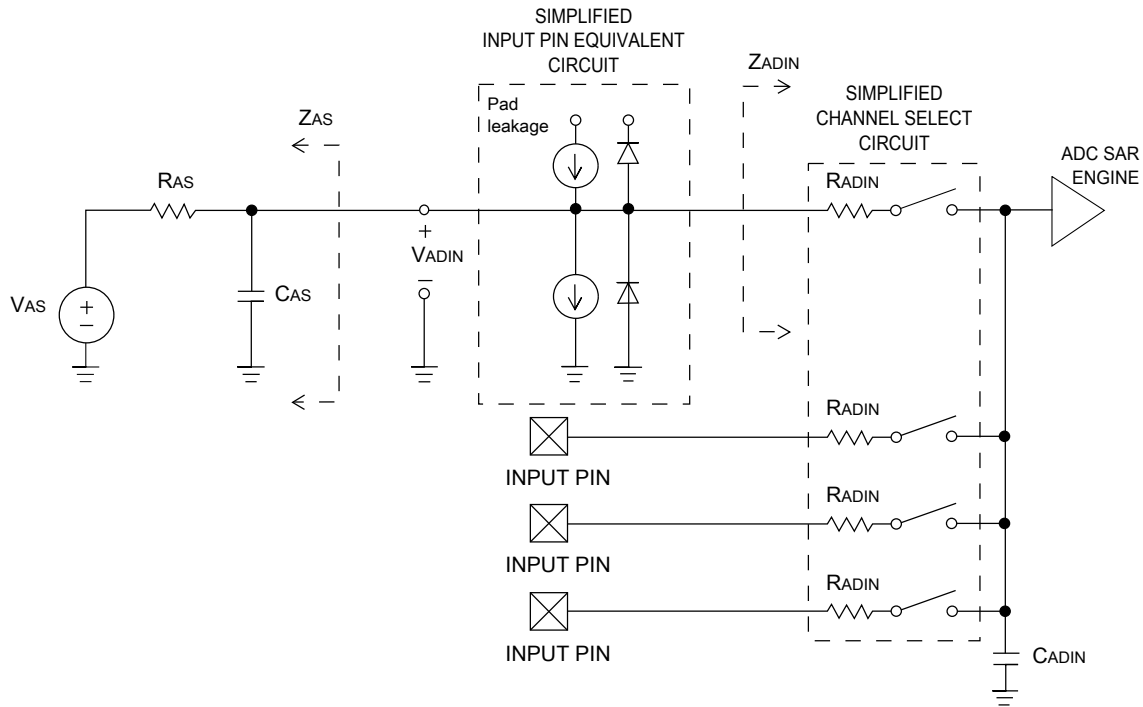

Figure 14. ADC input impedance equivalency diagram

3.6.1.2 16-bit ADC electrical characteristics

Table 30. 16-bit ADC characteristics ($V_{REFH} = V_{DDA}$, $V_{REFL} = V_{SSA}$)

Symbol	Description	Conditions ¹	Min.	Typ. ²	Max.	Unit	Notes
I_{DDA_ADC}	Supply current		0.215	—	1.7	mA	3
f_{ADACK}	ADC asynchronous clock source	• ADLPC = 1, ADHSC = 0	1.2	2.4	3.9	MHz	$t_{ADACK} = 1/f_{ADACK}$
		• ADLPC = 1, ADHSC = 1	2.4	4.0	6.1	MHz	
		• ADLPC = 0, ADHSC = 0	3.0	5.2	7.3	MHz	
		• ADLPC = 0, ADHSC = 1	4.4	6.2	9.5	MHz	
	Sample Time	See Reference Manual chapter for sample times					
TUE	Total unadjusted error	• 12-bit modes • <12-bit modes	—	±4 ±1.4	±6.8 ±2.1	LSB ⁴	5
DNL	Differential non-linearity	• 12-bit modes • <12-bit modes	—	±0.7 ±0.2	-1.1 to +1.9 -0.3 to 0.5	LSB ⁴	5
INL	Integral non-linearity	• 12-bit modes	—	±1.0	-2.7 to +1.9	LSB ⁴	5

Table continues on the next page...

Table 30. 16-bit ADC characteristics ($V_{REFH} = V_{DDA}$, $V_{REFL} = V_{SSA}$) (continued)

Symbol	Description	Conditions ¹	Min.	Typ. ²	Max.	Unit	Notes
		<ul style="list-style-type: none"> <12-bit modes 	—	±0.5	-0.7 to +0.5		
E_{FS}	Full-scale error	<ul style="list-style-type: none"> 12-bit modes <12-bit modes 	—	-4	-5.4	LSB ⁴	$V_{ADIN} = V_{DDA}$ ⁵
E_Q	Quantization error	<ul style="list-style-type: none"> 16-bit modes ≤13-bit modes 	—	-1 to 0	—	LSB ⁴	
ENOB	Effective number of bits	16-bit differential mode					6
		<ul style="list-style-type: none"> Avg = 32 Avg = 4 	12.8	14.5	—	bits	
			11.9	13.8	—	bits	
		16-bit single-ended mode					
<ul style="list-style-type: none"> Avg = 32 Avg = 4 	12.2	13.9	—	bits			
			11.4	13.1	—	bits	
SINAD	Signal-to-noise plus distortion	See ENOB	6.02 × ENOB + 1.76			dB	
THD	Total harmonic distortion	16-bit differential mode				dB	7
		<ul style="list-style-type: none"> Avg = 32 	—	-94	—	dB	
		16-bit single-ended mode					
		<ul style="list-style-type: none"> Avg = 32 	—	-85	—		
SFDR	Spurious free dynamic range	16-bit differential mode				dB	7
		<ul style="list-style-type: none"> Avg = 32 	82	95	—	dB	
		16-bit single-ended mode					
		<ul style="list-style-type: none"> Avg = 32 	78	90			
E_{IL}	Input leakage error		$I_{in} \times R_{AS}$			mV	I_{in} = leakage current (refer to the MCU's voltage and current operating ratings)
	Temp sensor slope	Across the full temperature range of the device	1.55	1.62	1.69	mV/°C	8
V_{TEMP25}	Temp sensor voltage	25 °C	706	716	726	mV	8

1. All accuracy numbers assume the ADC is calibrated with $V_{REFH} = V_{DDA}$

2. Typical values assume $V_{DDA} = 3.0$ V, Temp = 25 °C, $f_{ADCK} = 2.0$ MHz unless otherwise stated. Typical values are for reference only and are not tested in production.

3. The ADC supply current depends on the ADC conversion clock speed, conversion rate and ADC_CFG1[ADLPC] (low power). For lowest power operation, ADC_CFG1[ADLPC] must be set, the ADC_CFG2[ADHSC] bit must be clear with 1 MHz ADC conversion clock speed.
4. $1 \text{ LSB} = (V_{\text{REFH}} - V_{\text{REFL}})/2^N$
5. ADC conversion clock < 16 MHz, Max hardware averaging (AVGE = %1, AVGS = %11)
6. Input data is 100 Hz sine wave. ADC conversion clock < 12 MHz.
7. Input data is 1 kHz sine wave. ADC conversion clock < 12 MHz.
8. ADC conversion clock < 3 MHz

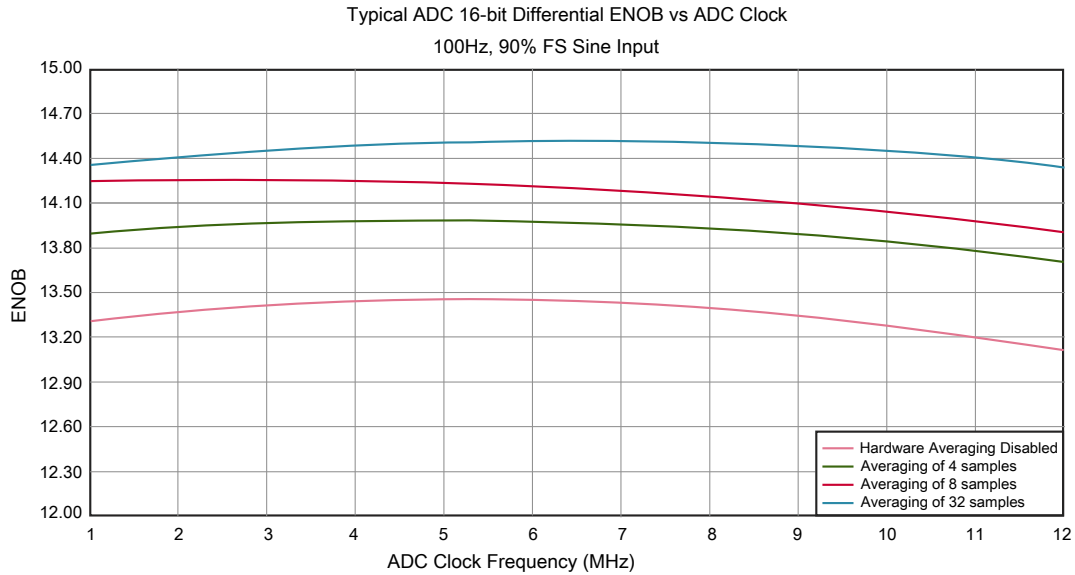

Figure 15. Typical ENOB vs. ADC_CLK for 16-bit differential mode

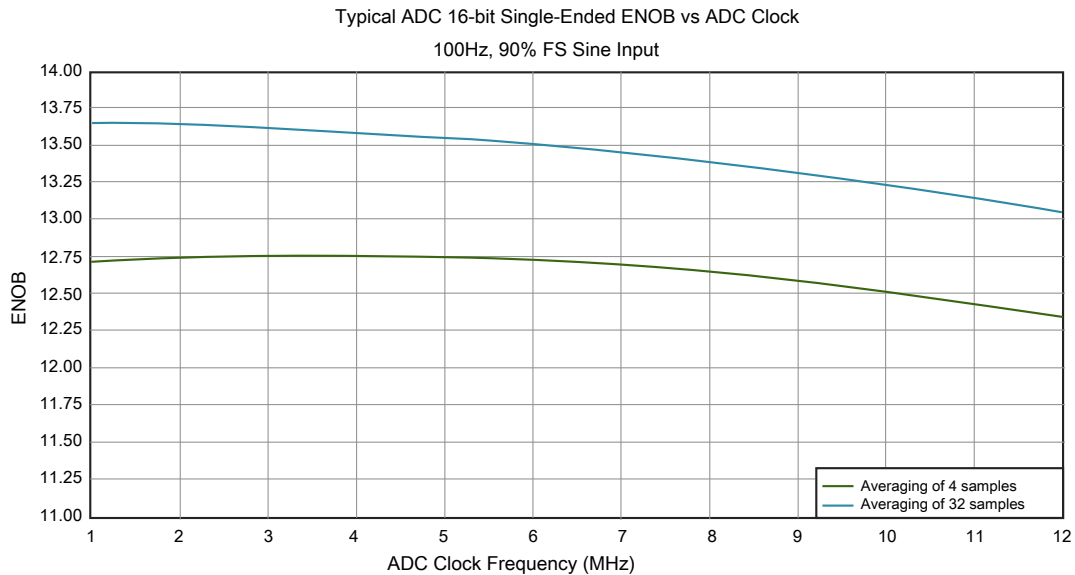

Figure 16. Typical ENOB vs. ADC_CLK for 16-bit single-ended mode

3.6.2 CMP and 6-bit DAC electrical specifications

Table 31. Comparator and 6-bit DAC electrical specifications

Symbol	Description	Min.	Typ.	Max.	Unit
V_{DD}	Supply voltage	1.71	—	3.6	V
I_{DDHS}	Supply current, high-speed mode (EN=1, PMODE=1)	—	—	200	μ A
I_{DDL5}	Supply current, low-speed mode (EN=1, PMODE=0)	—	—	20	μ A
V_{AIN}	Analog input voltage	$V_{SS} - 0.3$	—	V_{DD}	V
V_{AIO}	Analog input offset voltage	—	—	20	mV
V_H	Analog comparator hysteresis ¹ <ul style="list-style-type: none"> • CR0[HYSTCTR] = 00 • CR0[HYSTCTR] = 01 • CR0[HYSTCTR] = 10 • CR0[HYSTCTR] = 11 	—	5 10 20 30	—	mV mV mV mV
V_{CMPOh}	Output high	$V_{DD} - 0.5$	—	—	V
V_{CMPOl}	Output low	—	—	0.5	V
t_{DHS}	Propagation delay, high-speed mode (EN=1, PMODE=1)	20	50	200	ns
t_{DLS}	Propagation delay, low-speed mode (EN=1, PMODE=0)	80	250	600	ns
	Analog comparator initialization delay ²	—	—	40	μ s
I_{DAC6b}	6-bit DAC current adder (enabled)	—	7	—	μ A
INL	6-bit DAC integral non-linearity	-0.5	—	0.5	LSB ³
DNL	6-bit DAC differential non-linearity	-0.3	—	0.3	LSB

1. Typical hysteresis is measured with input voltage range limited to 0.6 to $V_{DD}-0.6$ V.
2. Comparator initialization delay is defined as the time between software writes to change control inputs (Writes to CMP_DACCR[DACEN], CMP_DACCR[VRSEL], CMP_DACCR[VOSEL], CMP_MUXCR[PSEL], and CMP_MUXCR[MSEL]) and the comparator output settling to a stable level.
3. 1 LSB = $V_{reference}/64$

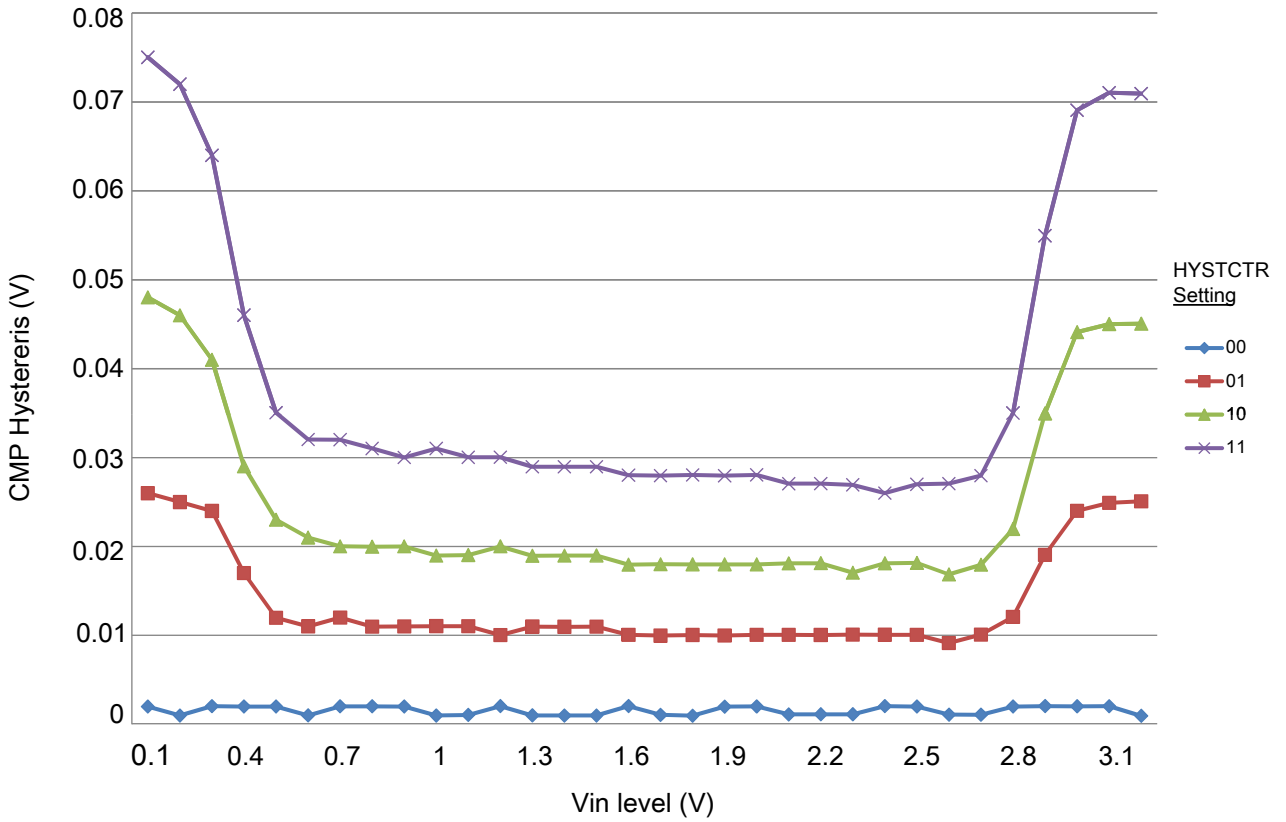

Figure 17. Typical hysteresis vs. Vin level (VDD = 3.3 V, PMODE = 0)

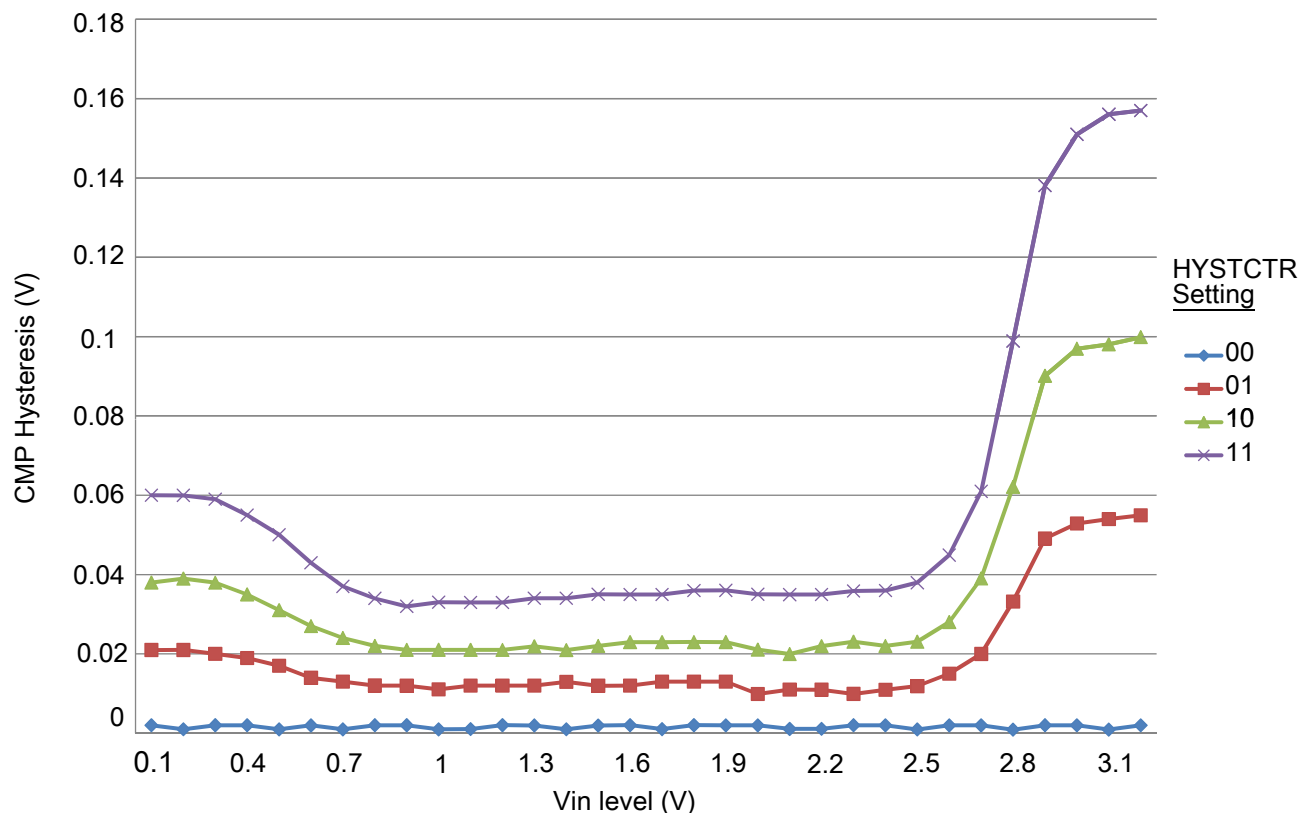

Figure 18. Typical hysteresis vs. Vin level (VDD = 3.3 V, PMODE = 1)

3.6.3 12-bit DAC electrical characteristics

3.6.3.1 12-bit DAC operating requirements

Table 32. 12-bit DAC operating requirements

Symbol	Description	Min.	Max.	Unit	Notes
V_{DDA}	Supply voltage	1.71	3.6	V	
V_{DACR}	Reference voltage	1.13	3.6	V	1
C_L	Output load capacitance	—	100	pF	2
I_L	Output load current	—	1	mA	

1. The DAC reference can be selected to be V_{DDA} or V_{REF_OUT} .
2. A small load capacitance (47 pF) can improve the bandwidth performance of the DAC.

3.6.3.2 12-bit DAC operating behaviors

Table 33. 12-bit DAC operating behaviors

Symbol	Description	Min.	Typ.	Max.	Unit	Notes
I_{DDA_DACLP}	Supply current — low-power mode	—	—	330	μA	
I_{DDA_DACHP}	Supply current — high-speed mode	—	—	1200	μA	
t_{DACLP}	Full-scale settling time (0x080 to 0xF7F) — low-power mode	—	100	200	μs	1
t_{DACHP}	Full-scale settling time (0x080 to 0xF7F) — high-power mode	—	15	30	μs	1
$t_{CCDACLP}$	Code-to-code settling time (0xBF8 to 0xC08) — low-power mode and high-speed mode	—	0.7	1	μs	1
$V_{dacoutl}$	DAC output voltage range low — high-speed mode, no load, DAC set to 0x000	—	—	100	mV	
$V_{dacouth}$	DAC output voltage range high — high-speed mode, no load, DAC set to 0xFFFF	$V_{DACR} - 100$	—	V_{DACR}	mV	
INL	Integral non-linearity error — high speed mode	—	—	± 8	LSB	2
DNL	Differential non-linearity error — $V_{DACR} > 2\text{ V}$	—	—	± 1	LSB	3
DNL	Differential non-linearity error — $V_{DACR} = V_{REF_OUT}$	—	—	± 1	LSB	4
V_{OFFSET}	Offset error	—	± 0.4	± 0.8	%FSR	5
E_G	Gain error	—	± 0.1	± 0.6	%FSR	5
PSRR	Power supply rejection ratio, $V_{DDA} \geq 2.4\text{ V}$	60	—	90	dB	
T_{CO}	Temperature coefficient offset voltage	—	3.7	—	$\mu\text{V}/\text{C}$	6
T_{GE}	Temperature coefficient gain error	—	0.000421	—	%FSR/C	
R_{op}	Output resistance (load = 3 k Ω)	—	—	250	Ω	
SR	Slew rate -80h→ F7Fh→ 80h <ul style="list-style-type: none"> High power (SP_{HP}) Low power (SP_{LP}) 	1.2 0.05	1.7 0.12	— —	$\text{V}/\mu\text{s}$	
BW	3dB bandwidth <ul style="list-style-type: none"> High power (SP_{HP}) Low power (SP_{LP}) 	550 40	— —	— —	kHz	

- Settling within ± 1 LSB
- The INL is measured for 0 + 100 mV to $V_{DACR} - 100$ mV
- The DNL is measured for 0 + 100 mV to $V_{DACR} - 100$ mV
- The DNL is measured for 0 + 100 mV to $V_{DACR} - 100$ mV with $V_{DDA} > 2.4\text{ V}$
- Calculated by a best fit curve from $V_{SS} + 100$ mV to $V_{DACR} - 100$ mV
- $V_{DDA} = 3.0\text{ V}$, reference select set for V_{DDA} ($\text{DACx_CO:DACRFS} = 1$), high power mode ($\text{DACx_CO:LPEN} = 0$), DAC set to 0x800, temperature range is across the full range of the device

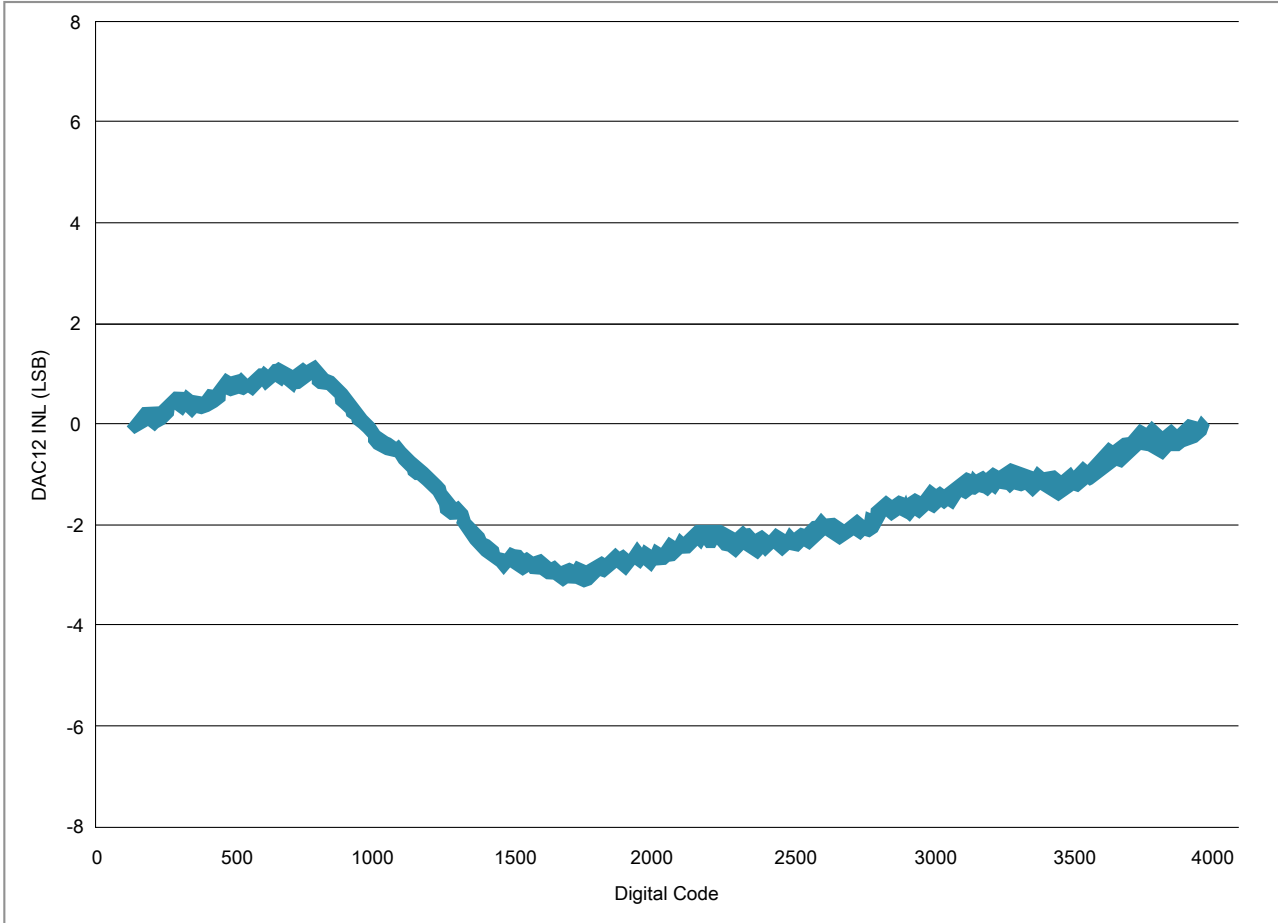

Figure 19. Typical INL error vs. digital code

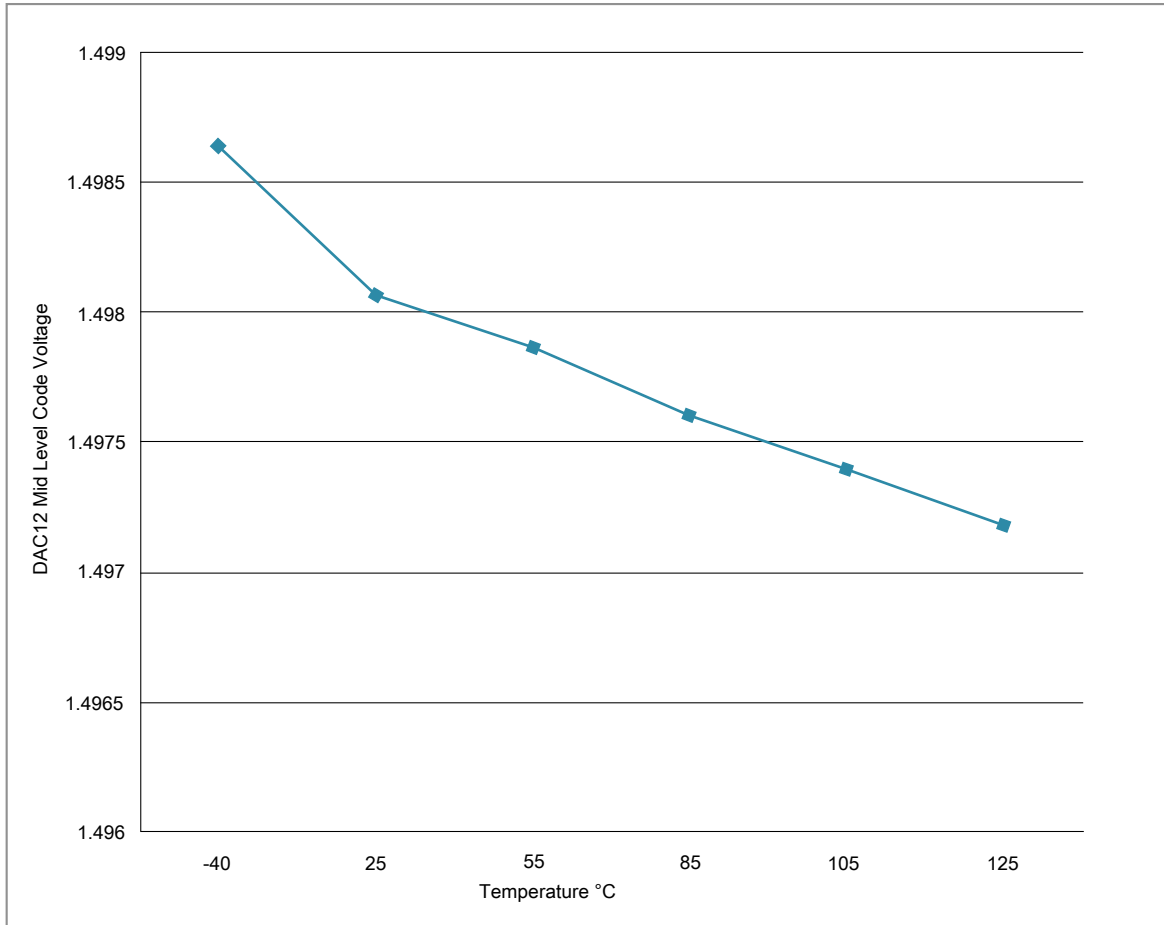

Figure 20. Offset at half scale vs. temperature

3.6.4 Voltage reference electrical specifications

Table 34. VREF full-range operating requirements

Symbol	Description	Min.	Max.	Unit	Notes
V_{DDA}	Supply voltage	1.71	3.6	V	
T_A	Temperature	Operating temperature range of the device		°C	
C_L	Output load capacitance	100		nF	1, 2

1. C_L must be connected to VREF_OUT if the VREF_OUT functionality is being used for either an internal or external reference.
2. The load capacitance should not exceed +/-25% of the nominal specified C_L value over the operating temperature range of the device.

Table 35. VREF full-range operating behaviors

Symbol	Description	Min.	Typ.	Max.	Unit	Notes
V_{out}	Voltage reference output with factory trim at nominal V_{DDA} and temperature= 25°C	1.1920	1.1950	1.1980	V	1
V_{out}	Voltage reference output with user trim at nominal V_{DDA} and temperature= 25°C	1.1945	1.1950	1.1955	V	1
V_{step}	Voltage reference trim step	—	0.5	—	mV	1
V_{tdrift}	Temperature drift ($V_{max} - V_{min}$ across the full temperature range)	—	—	15	mV	1
I_{bg}	Bandgap only current	—	—	80	μA	
I_{lp}	Low-power buffer current	—	—	360	μA	1
I_{hp}	High-power buffer current	—	—	1	mA	1
ΔV_{LOAD}	Load regulation • current = ± 1.0 mA	—	200	—	μV	1, 2
T_{stup}	Buffer startup time	—	—	100	μs	
$T_{chop_osc_st\ up}$	Internal bandgap start-up delay with chop oscillator enabled	—	—	35	ms	
V_{vdrift}	Voltage drift ($V_{max} - V_{min}$ across the full voltage range)	—	2	—	mV	1

1. See the chip's Reference Manual for the appropriate settings of the VREF Status and Control register.
2. Load regulation voltage is the difference between the VREF_OUT voltage with no load vs. voltage with defined load

Table 36. VREF limited-range operating requirements

Symbol	Description	Min.	Max.	Unit	Notes
T_A	Temperature	0	70	$^{\circ}\text{C}$	

Table 37. VREF limited-range operating behaviors

Symbol	Description	Min.	Max.	Unit	Notes
V_{tdrift}	Temperature drift ($V_{max} - V_{min}$ across the limited temperature range)	—	10	mV	

3.7 Timers

See [General switching specifications](#).

3.8 Communication interfaces

3.8.1 USB electrical specifications

The USB electricals for the USB On-the-Go module conform to the standards documented by the Universal Serial Bus Implementers Forum. For the most up-to-date standards, visit usb.org.

NOTE

The MCGPLLCLK meets the USB jitter and signaling rate specifications for certification with the use of an external clock/crystal for both Device and Host modes.

The MCGFLLCLK does not meet the USB jitter or signaling rate specifications for certification.

The IRC48M meets the USB jitter and signaling rate specifications for certification in Device mode when the USB clock recovery mode is enabled. It does not meet the USB signaling rate specifications for certification in Host mode operation.

3.8.2 USB VREG electrical specifications

Table 38. USB VREG electrical specifications

Symbol	Description	Min.	Typ. ¹	Max.	Unit	Notes
VREGIN	Input supply voltage	2.7	—	5.5	V	
I _{DDon}	Quiescent current — Run mode, load current equal zero, input supply (VREGIN) > 3.6 V	—	125	186	μA	
I _{DDstby}	Quiescent current — Standby mode, load current equal zero	—	1.1	10	μA	
I _{DDoff}	Quiescent current — Shutdown mode <ul style="list-style-type: none"> • VREGIN = 5.0 V and temperature=25 °C • Across operating voltage and temperature 	—	650	—	nA	
		—	—	4	μA	
I _{LOADrun}	Maximum load current — Run mode	—	—	120	mA	
I _{LOADstby}	Maximum load current — Standby mode	—	—	1	mA	
V _{Reg33out}	Regulator output voltage — Input supply (VREGIN) > 3.6 V <ul style="list-style-type: none"> • Run mode • Standby mode 	3	3.3	3.6	V	
		2.1	2.8	3.6	V	

Table continues on the next page...

Table 38. USB VREG electrical specifications (continued)

Symbol	Description	Min.	Typ. ¹	Max.	Unit	Notes
V _{Reg33out}	Regulator output voltage — Input supply (VREGIN) < 3.6 V, pass-through mode	2.1	—	3.6	V	2
C _{OUT}	External output capacitor	1.76	2.2	8.16	μF	
ESR	External output capacitor equivalent series resistance	1	—	100	mΩ	
I _{LIM}	Short circuit current	—	290	—	mA	

1. Typical values assume VREGIN = 5.0 V, Temp = 25 °C unless otherwise stated.

2. Operating in pass-through mode: regulator output voltage equal to the input voltage minus a drop proportional to I_{Load}.

3.8.3 DSPI switching specifications (limited voltage range)

The Deserial Serial Peripheral Interface (DSPI) provides a synchronous serial bus with master and slave operations. Many of the transfer attributes are programmable. The tables below provide DSPI timing characteristics for classic SPI timing modes. Refer to the SPI chapter of the Reference Manual for information on the modified transfer formats used for communicating with slower peripheral devices.

Table 39. Master mode DSPI timing (limited voltage range)

Num	Description	Min.	Max.	Unit	Notes
	Operating voltage	2.7	3.6	V	
	Frequency of operation	—	30	MHz	
DS1	DSPI_SCK output cycle time	2 x t _{BUS}	—	ns	
DS2	DSPI_SCK output high/low time	(t _{SCK} /2) - 2	(t _{SCK} /2) + 2	ns	
DS3	DSPI_PCS _n valid to DSPI_SCK delay	(t _{BUS} x 2) - 2	—	ns	1
DS4	DSPI_SCK to DSPI_PCS _n invalid delay	(t _{BUS} x 2) - 2	—	ns	2
DS5	DSPI_SCK to DSPI_SOUT valid	—	8.5	ns	
DS6	DSPI_SCK to DSPI_SOUT invalid	-2	—	ns	
DS7	DSPI_SIN to DSPI_SCK input setup	16.2	—	ns	
DS8	DSPI_SCK to DSPI_SIN input hold	0	—	ns	

1. The delay is programmable in SPIx_CTARn[PSSCK] and SPIx_CTARn[CSSCK].

2. The delay is programmable in SPIx_CTARn[PASC] and SPIx_CTARn[ASC].

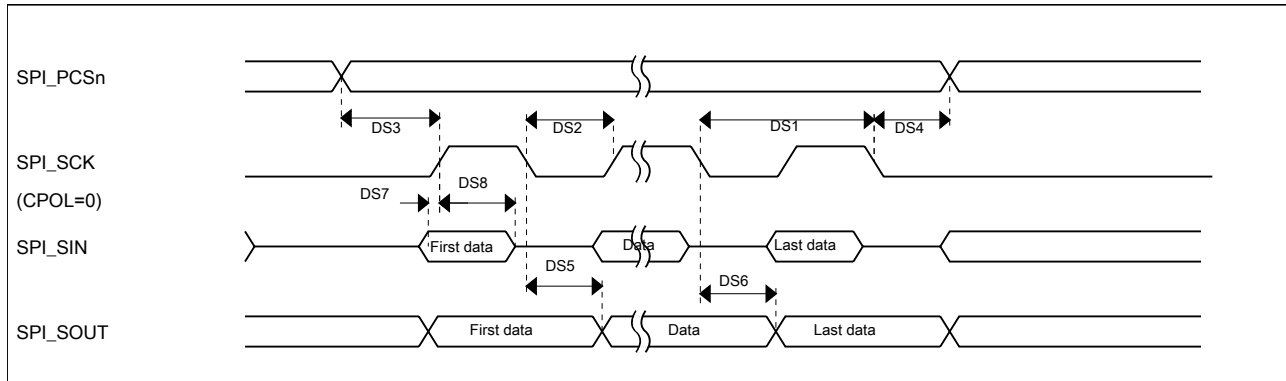

Figure 21. DSPI classic SPI timing — master mode

Table 40. Slave mode DSPI timing (limited voltage range)

Num	Description	Min.	Max.	Unit	Notes
	Operating voltage	2.7	3.6	V	
	Frequency of operation	—	15	MHz	1
DS9	DSPI_SCK input cycle time	$4 \times t_{\text{BUS}}$	—	ns	
DS10	DSPI_SCK input high/low time	$(t_{\text{SCK}}/2) - 2$	$(t_{\text{SCK}}/2) + 2$	ns	
DS11	DSPI_SCK to DSPI_SOUT valid	—	21.4	ns	
DS12	DSPI_SCK to DSPI_SOUT invalid	0	—	ns	
DS13	DSPI_SIN to DSPI_SCK input setup	2.6	—	ns	
DS14	DSPI_SCK to DSPI_SIN input hold	7	—	ns	
DS15	$\overline{\text{DSPI_SS}}$ active to DSPI_SOUT driven	—	17	ns	
DS16	$\overline{\text{DSPI_SS}}$ inactive to DSPI_SOUT not driven	—	17	ns	

1. The maximum operating frequency is measured with noncontinuous CS and SCK. When DSPI is configured with continuous CS and SCK, the SPI clock must not be greater than 1/6 of the bus clock. For example, when the bus clock is 60 MHz, the SPI clock must not be greater than 10 MHz.

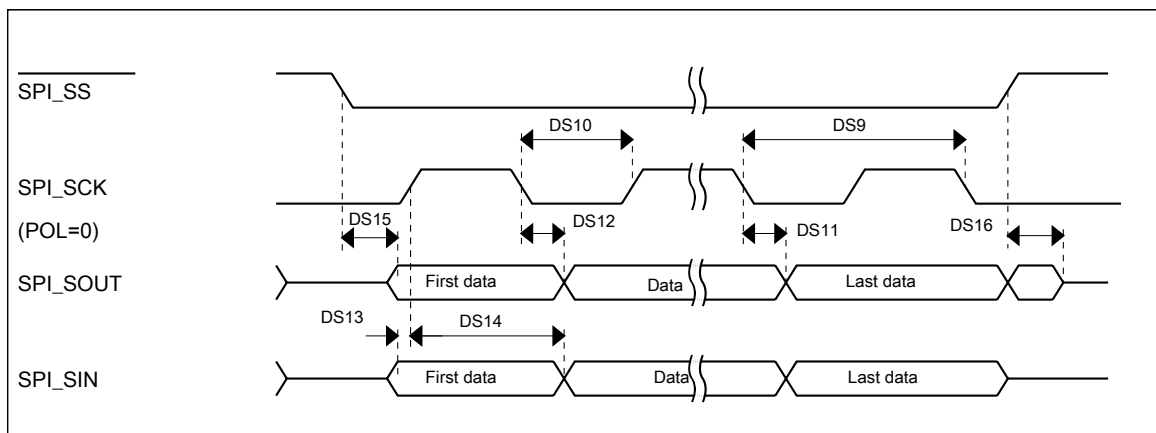

Figure 22. DSPI classic SPI timing — slave mode

3.8.4 DSPI switching specifications (full voltage range)

The Deserial Serial Peripheral Interface (DSPI) provides a synchronous serial bus with master and slave operations. Many of the transfer attributes are programmable. The tables below provides DSPI timing characteristics for classic SPI timing modes. Refer to the SPI chapter of the Reference Manual for information on the modified transfer formats used for communicating with slower peripheral devices.

Table 41. Master mode DSPI timing (full voltage range)

Num	Description	Min.	Max.	Unit	Notes
	Operating voltage	1.71	3.6	V	1
	Frequency of operation	—	15	MHz	
DS1	DSPI_SCK output cycle time	$4 \times t_{BUS}$	—	ns	
DS2	DSPI_SCK output high/low time	$(t_{SCK/2}) - 4$	$(t_{SCK/2}) + 4$	ns	
DS3	DSPI_PCSn valid to DSPI_SCK delay	$(t_{BUS} \times 2) - 4$	—	ns	2
DS4	DSPI_SCK to DSPI_PCSn invalid delay	$(t_{BUS} \times 2) - 4$	—	ns	3
DS5	DSPI_SCK to DSPI_SOUT valid	—	10	ns	
DS6	DSPI_SCK to DSPI_SOUT invalid	-4.5	—	ns	
DS7	DSPI_SIN to DSPI_SCK input setup	24.6	—	ns	
DS8	DSPI_SCK to DSPI_SIN input hold	0	—	ns	

1. The DSPI module can operate across the entire operating voltage for the processor, but to run across the full voltage range the maximum frequency of operation is reduced.
2. The delay is programmable in SPIx_CTARn[PSSCK] and SPIx_CTARn[CSSCK].
3. The delay is programmable in SPIx_CTARn[PASC] and SPIx_CTARn[ASC].

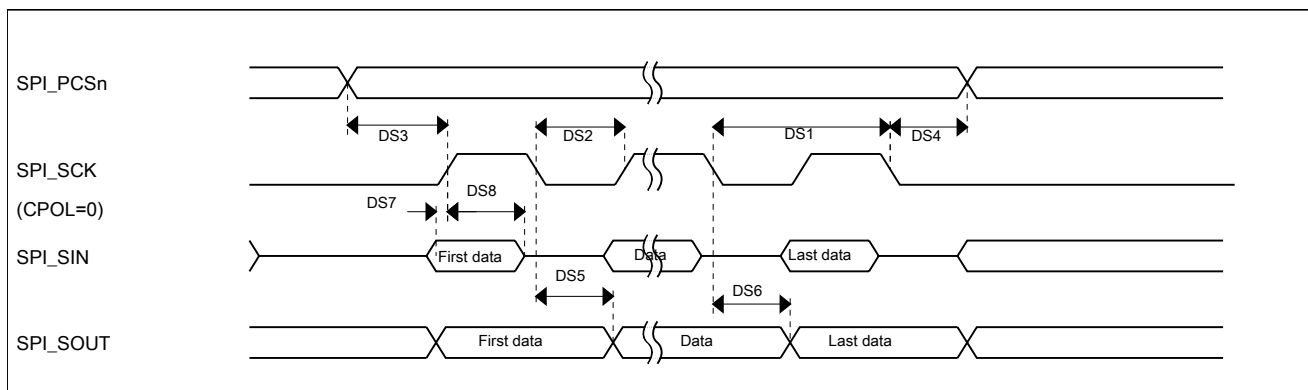
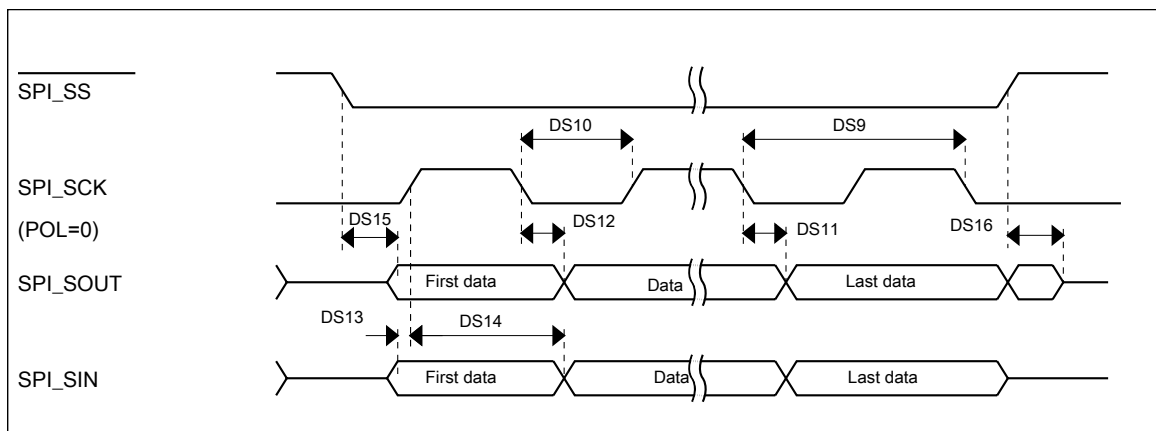

Figure 23. DSPI classic SPI timing — master mode

Table 42. Slave mode DSPI timing (full voltage range)

Num	Description	Min.	Max.	Unit
	Operating voltage	1.71	3.6	V
	Frequency of operation	—	7.5	MHz
DS9	DSPI_SCK input cycle time	$8 \times t_{\text{BUS}}$	—	ns
DS10	DSPI_SCK input high/low time	$(t_{\text{SCK}}/2) - 4$	$(t_{\text{SCK}}/2) + 4$	ns
DS11	DSPI_SCK to DSPI_SOUT valid	—	29.5	ns
DS12	DSPI_SCK to DSPI_SOUT invalid	0	—	ns
DS13	DSPI_SIN to DSPI_SCK input setup	3.2	—	ns
DS14	DSPI_SCK to DSPI_SIN input hold	7	—	ns
DS15	$\overline{\text{DSPI_SS}}$ active to DSPI_SOUT driven	—	25	ns
DS16	$\overline{\text{DSPI_SS}}$ inactive to DSPI_SOUT not driven	—	25	ns

**Figure 24. DSPI classic SPI timing — slave mode**

3.8.5 Inter-Integrated Circuit Interface (I²C) timing

Table 43. I²C timing

Characteristic	Symbol	Standard Mode		Fast Mode		Unit
		Minimum	Maximum	Minimum	Maximum	
SCL Clock Frequency	f_{SCL}	0	100	0	400 ¹	kHz
Hold time (repeated) START condition. After this period, the first clock pulse is generated.	t_{HD} ; STA	4	—	0.6	—	μs
LOW period of the SCL clock	t_{LOW}	4.7	—	1.25	—	μs
HIGH period of the SCL clock	t_{HIGH}	4	—	0.6	—	μs
Set-up time for a repeated START condition	t_{SU} ; STA	4.7	—	0.6	—	μs

Table continues on the next page...

Table 43. I²C timing (continued)

Characteristic	Symbol	Standard Mode		Fast Mode		Unit
		Minimum	Maximum	Minimum	Maximum	
Data hold time for I ² C bus devices	t _{HD} ; DAT	0 ²	3.45 ³	0 ⁴	0.9 ²	μs
Data set-up time	t _{SU} ; DAT	250 ⁵	—	100 ^{3, 6}	—	ns
Rise time of SDA and SCL signals	t _r	—	1000	20 + 0.1C _b ⁷	300	ns
Fall time of SDA and SCL signals	t _f	—	300	20 + 0.1C _b ⁶	300	ns
Set-up time for STOP condition	t _{SU} ; STO	4	—	0.6	—	μs
Bus free time between STOP and START condition	t _{BUF}	4.7	—	1.3	—	μs
Pulse width of spikes that must be suppressed by the input filter	t _{SP}	N/A	N/A	0	50	ns

1. The maximum SCL Clock Frequency in Fast mode with maximum bus loading can only be achieved when using the High drive pins across the full voltage range and when using the Normal drive pins and VDD ≥ 2.7 V.
2. The master mode I²C deasserts ACK of an address byte simultaneously with the falling edge of SCL. If no slaves acknowledge this address byte, then a negative hold time can result, depending on the edge rates of the SDA and SCL lines.
3. The maximum t_{HD}; DAT must be met only if the device does not stretch the LOW period (t_{LOW}) of the SCL signal.
4. Input signal Slew = 10 ns and Output Load = 50 pF
5. Set-up time in slave-transmitter mode is 1 IPBus clock period, if the TX FIFO is empty.
6. A Fast mode I²C bus device can be used in a Standard mode I²C bus system, but the requirement t_{SU}; DAT ≥ 250 ns must then be met. This is automatically the case if the device does not stretch the LOW period of the SCL signal. If such a device does stretch the LOW period of the SCL signal, then it must output the next data bit to the SDA line t_{rmax} + t_{SU}; DAT = 1000 + 250 = 1250 ns (according to the Standard mode I²C bus specification) before the SCL line is released.
7. C_b = total capacitance of the one bus line in pF.

Table 44. I²C 1 Mbps timing

Characteristic	Symbol	Minimum	Maximum	Unit
SCL Clock Frequency	f _{SCL}	0	1 ¹	MHz
Hold time (repeated) START condition. After this period, the first clock pulse is generated.	t _{HD} ; STA	0.26	—	μs
LOW period of the SCL clock	t _{LOW}	0.5	—	μs
HIGH period of the SCL clock	t _{HIGH}	0.26	—	μs
Set-up time for a repeated START condition	t _{SU} ; STA	0.26	—	μs
Data hold time for I ² C bus devices	t _{HD} ; DAT	0	—	μs
Data set-up time	t _{SU} ; DAT	50	—	ns
Rise time of SDA and SCL signals	t _r	20 + 0.1C _b ²	120	ns
Fall time of SDA and SCL signals	t _f	20 + 0.1C _b ²	120	ns
Set-up time for STOP condition	t _{SU} ; STO	0.26	—	μs
Bus free time between STOP and START condition	t _{BUF}	0.5	—	μs
Pulse width of spikes that must be suppressed by the input filter	t _{SP}	0	50	ns

1. The maximum SCL clock frequency of 1 Mbps can support maximum bus loading when using the High drive pins across the full voltage range.
2. C_b = total capacitance of the one bus line in pF.

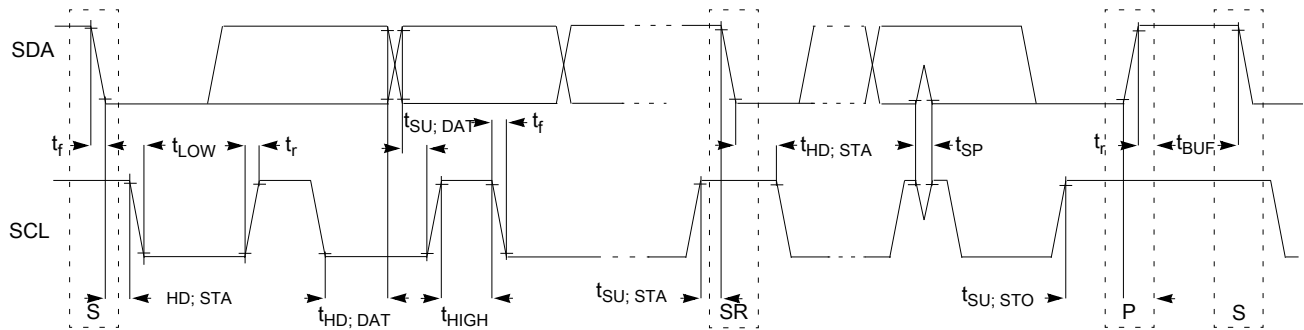

Figure 25. Timing definition for devices on the I²C bus

3.8.6 UART switching specifications

See [General switching specifications](#).

3.8.7 I2S/SAI switching specifications

This section provides the AC timing for the I2S/SAI module in master mode (clocks are driven) and slave mode (clocks are input). All timing is given for noninverted serial clock polarity (TCR2[BCP] is 0, RCR2[BCP] is 0) and a noninverted frame sync (TCR4[FSP] is 0, RCR4[FSP] is 0). If the polarity of the clock and/or the frame sync have been inverted, all the timing remains valid by inverting the bit clock signal (BCLK) and/or the frame sync (FS) signal shown in the following figures.

3.8.7.1 Normal Run, Wait and Stop mode performance over a limited operating voltage range

This section provides the operating performance over a limited operating voltage for the device in Normal Run, Wait and Stop modes.

Table 45. I2S/SAI master mode timing in Normal Run, Wait and Stop modes (limited voltage range)

Num.	Characteristic	Min.	Max.	Unit
	Operating voltage	2.7	3.6	V
S1	I2S_MCLK cycle time	40	—	ns
S2	I2S_MCLK pulse width high/low	45%	55%	MCLK period
S3	I2S_TX_BCLK/I2S_RX_BCLK cycle time (output)	80	—	ns
S4	I2S_TX_BCLK/I2S_RX_BCLK pulse width high/low	45%	55%	BCLK period

Table continues on the next page...

Table 45. I2S/SAI master mode timing in Normal Run, Wait and Stop modes (limited voltage range) (continued)

Num.	Characteristic	Min.	Max.	Unit
S5	I2S_TX_BCLK/I2S_RX_BCLK to I2S_TX_FS/ I2S_RX_FS output valid	—	15	ns
S6	I2S_TX_BCLK/I2S_RX_BCLK to I2S_TX_FS/ I2S_RX_FS output invalid	0	—	ns
S7	I2S_TX_BCLK to I2S_TXD valid	—	15	ns
S8	I2S_TX_BCLK to I2S_TXD invalid	0	—	ns
S9	I2S_RXD/I2S_RX_FS input setup before I2S_RX_BCLK	18	—	ns
S10	I2S_RXD/I2S_RX_FS input hold after I2S_RX_BCLK	0	—	ns

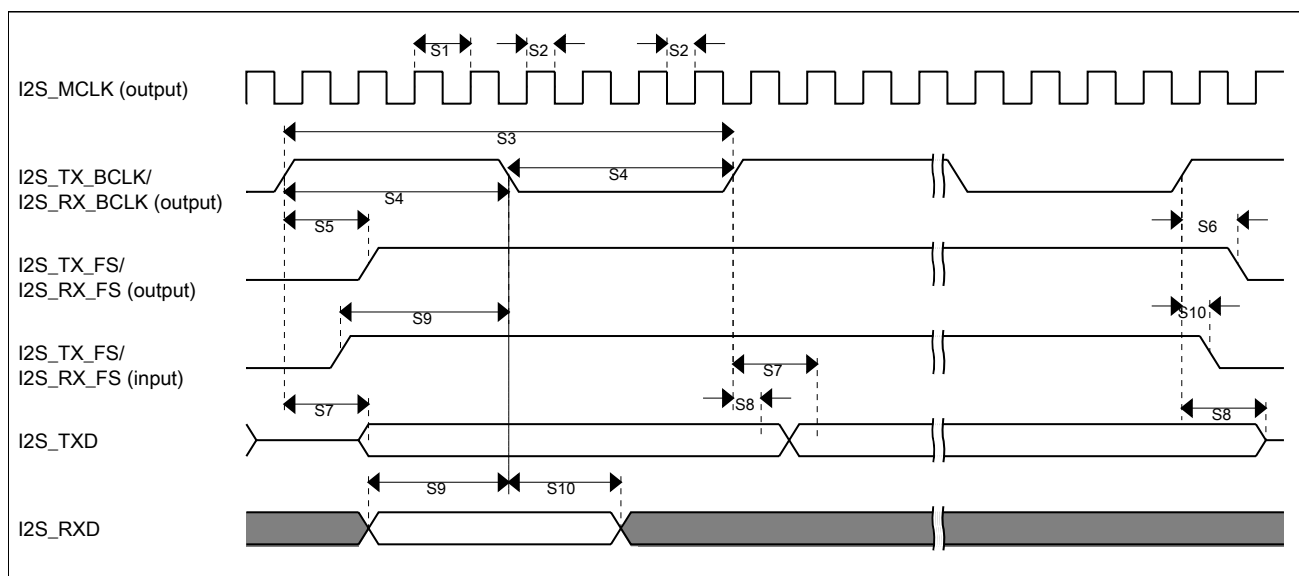

Figure 26. I2S/SAI timing — master modes

Table 46. I2S/SAI slave mode timing in Normal Run, Wait and Stop modes (limited voltage range)

Num.	Characteristic	Min.	Max.	Unit
	Operating voltage	2.7	3.6	V
S11	I2S_TX_BCLK/I2S_RX_BCLK cycle time (input)	80	—	ns
S12	I2S_TX_BCLK/I2S_RX_BCLK pulse width high/low (input)	45%	55%	MCLK period
S13	I2S_TX_FS/I2S_RX_FS input setup before I2S_TX_BCLK/I2S_RX_BCLK	4.5	—	ns
S14	I2S_TX_FS/I2S_RX_FS input hold after I2S_TX_BCLK/I2S_RX_BCLK	2	—	ns

Table continues on the next page...

Table 46. I2S/SAI slave mode timing in Normal Run, Wait and Stop modes (limited voltage range) (continued)

Num.	Characteristic	Min.	Max.	Unit
S15	I2S_TX_BCLK to I2S_TXD/I2S_TX_FS output valid	—	20	ns
S16	I2S_TX_BCLK to I2S_TXD/I2S_TX_FS output invalid	0	—	ns
S17	I2S_RXD setup before I2S_RX_BCLK	4.5	—	ns
S18	I2S_RXD hold after I2S_RX_BCLK	2	—	ns
S19	I2S_TX_FS input assertion to I2S_TXD output valid ¹	—	25	ns

1. Applies to first bit in each frame and only if the TCR4[FSE] bit is clear

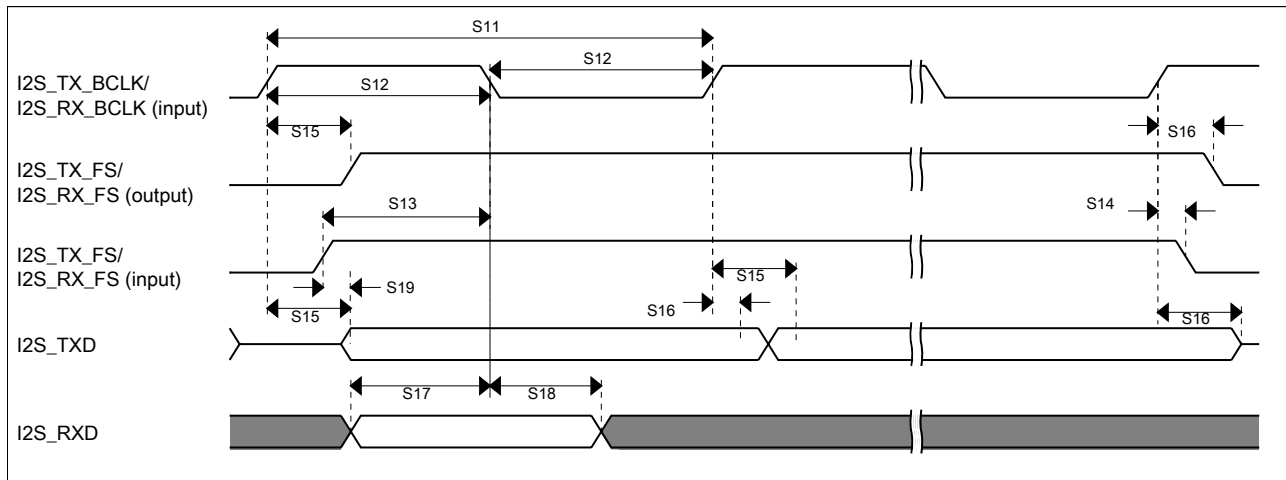
**Figure 27. I2S/SAI timing — slave modes**

3.8.7.2 Normal Run, Wait and Stop mode performance over the full operating voltage range

This section provides the operating performance over the full operating voltage for the device in Normal Run, Wait and Stop modes.

Table 47. I2S/SAI master mode timing in Normal Run, Wait and Stop modes (full voltage range)

Num.	Characteristic	Min.	Max.	Unit
	Operating voltage	1.71	3.6	V
S1	I2S_MCLK cycle time	40	—	ns
S2	I2S_MCLK pulse width high/low	45%	55%	MCLK period
S3	I2S_TX_BCLK/I2S_RX_BCLK cycle time (output)	80	—	ns
S4	I2S_TX_BCLK/I2S_RX_BCLK pulse width high/low	45%	55%	BCLK period

Table continues on the next page...

Table 47. I2S/SAI master mode timing in Normal Run, Wait and Stop modes (full voltage range) (continued)

Num.	Characteristic	Min.	Max.	Unit
S5	I2S_TX_BCLK/I2S_RX_BCLK to I2S_TX_FS/ I2S_RX_FS output valid	—	15	ns
S6	I2S_TX_BCLK/I2S_RX_BCLK to I2S_TX_FS/ I2S_RX_FS output invalid	-1.0	—	ns
S7	I2S_TX_BCLK to I2S_TXD valid	—	15	ns
S8	I2S_TX_BCLK to I2S_TXD invalid	0	—	ns
S9	I2S_RXD/I2S_RX_FS input setup before I2S_RX_BCLK	27	—	ns
S10	I2S_RXD/I2S_RX_FS input hold after I2S_RX_BCLK	0	—	ns

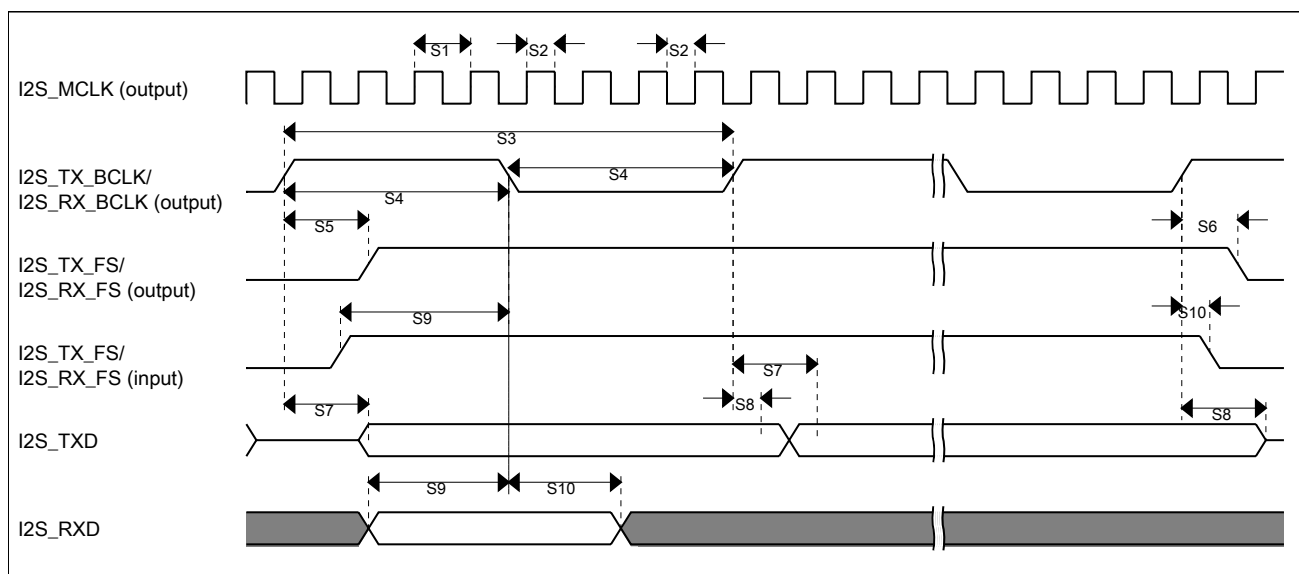

Figure 28. I2S/SAI timing — master modes

Table 48. I2S/SAI slave mode timing in Normal Run, Wait and Stop modes (full voltage range)

Num.	Characteristic	Min.	Max.	Unit
	Operating voltage	1.71	3.6	V
S11	I2S_TX_BCLK/I2S_RX_BCLK cycle time (input)	80	—	ns
S12	I2S_TX_BCLK/I2S_RX_BCLK pulse width high/low (input)	45%	55%	MCLK period
S13	I2S_TX_FS/I2S_RX_FS input setup before I2S_TX_BCLK/I2S_RX_BCLK	5.8	—	ns
S14	I2S_TX_FS/I2S_RX_FS input hold after I2S_TX_BCLK/I2S_RX_BCLK	2	—	ns

Table continues on the next page...

Table 48. I2S/SAI slave mode timing in Normal Run, Wait and Stop modes (full voltage range) (continued)

Num.	Characteristic	Min.	Max.	Unit
S15	I2S_TX_BCLK to I2S_TXD/I2S_TX_FS output valid	—	28.5	ns
S16	I2S_TX_BCLK to I2S_TXD/I2S_TX_FS output invalid	0	—	ns
S17	I2S_RXD setup before I2S_RX_BCLK	5.8	—	ns
S18	I2S_RXD hold after I2S_RX_BCLK	2	—	ns
S19	I2S_TX_FS input assertion to I2S_TXD output valid ¹	—	26.3	ns

1. Applies to first bit in each frame and only if the TCR4[FSE] bit is clear

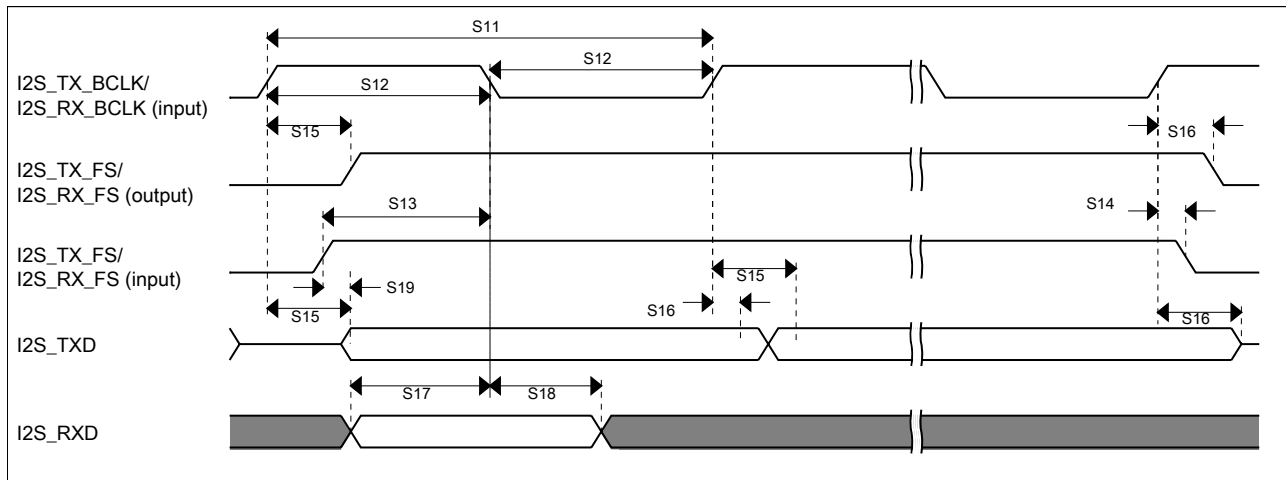
**Figure 29. I2S/SAI timing — slave modes**

3.8.7.3 VLPR, VLPW, and VLPS mode performance over the full operating voltage range

This section provides the operating performance over the full operating voltage for the device in VLPR, VLPW, and VLPS modes.

Table 49. I2S/SAI master mode timing in VLPR, VLPW, and VLPS modes (full voltage range)

Num.	Characteristic	Min.	Max.	Unit
	Operating voltage	1.71	3.6	V
S1	I2S_MCLK cycle time	62.5	—	ns
S2	I2S_MCLK pulse width high/low	45%	55%	MCLK period
S3	I2S_TX_BCLK/I2S_RX_BCLK cycle time (output)	250	—	ns
S4	I2S_TX_BCLK/I2S_RX_BCLK pulse width high/low	45%	55%	BCLK period
S5	I2S_TX_BCLK/I2S_RX_BCLK to I2S_TX_FS/I2S_RX_FS output valid	—	45	ns

Table continues on the next page...

Table 49. I2S/SAI master mode timing in VLPR, VLPW, and VLPS modes (full voltage range) (continued)

Num.	Characteristic	Min.	Max.	Unit
S6	I2S_TX_BCLK/I2S_RX_BCLK to I2S_TX_FS/ I2S_RX_FS output invalid	-1	—	ns
S7	I2S_TX_BCLK to I2S_TXD valid	—	45	ns
S8	I2S_TX_BCLK to I2S_TXD invalid	0	—	ns
S9	I2S_RXD/I2S_RX_FS input setup before I2S_RX_BCLK	45	—	ns
S10	I2S_RXD/I2S_RX_FS input hold after I2S_RX_BCLK	0	—	ns

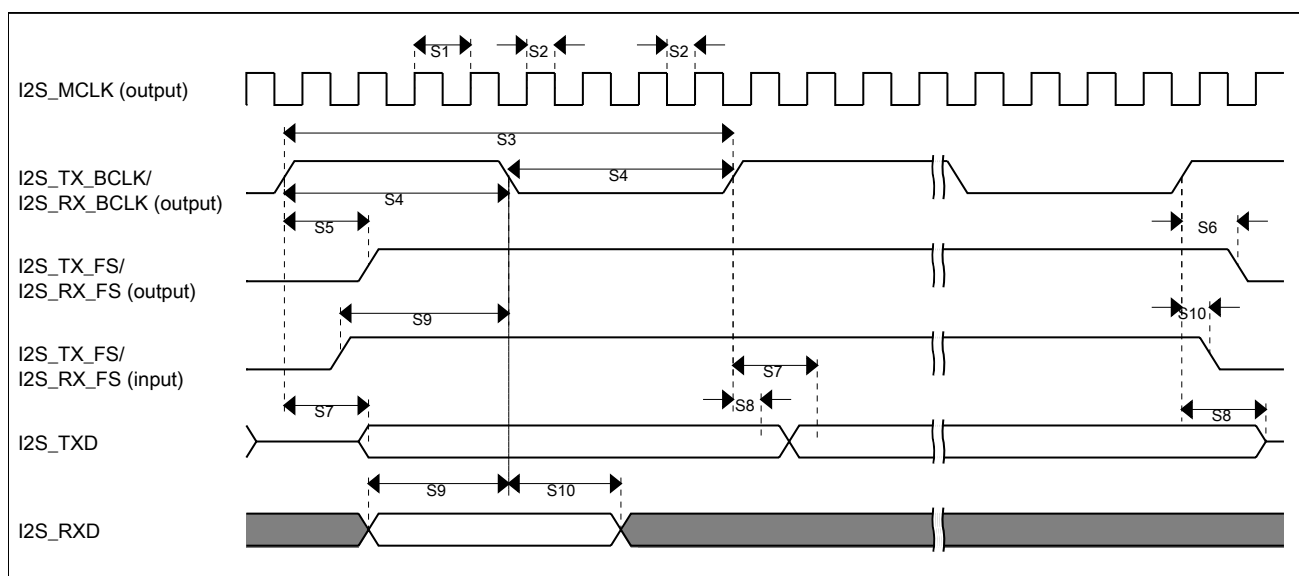

Figure 30. I2S/SAI timing — master modes

Table 50. I2S/SAI slave mode timing in VLPR, VLPW, and VLPS modes (full voltage range)

Num.	Characteristic	Min.	Max.	Unit
	Operating voltage	1.71	3.6	V
S11	I2S_TX_BCLK/I2S_RX_BCLK cycle time (input)	250	—	ns
S12	I2S_TX_BCLK/I2S_RX_BCLK pulse width high/low (input)	45%	55%	MCLK period
S13	I2S_TX_FS/I2S_RX_FS input setup before I2S_TX_BCLK/I2S_RX_BCLK	30	—	ns
S14	I2S_TX_FS/I2S_RX_FS input hold after I2S_TX_BCLK/I2S_RX_BCLK	7	—	ns
S15	I2S_TX_BCLK to I2S_TXD/I2S_TX_FS output valid	—	63	ns
S16	I2S_TX_BCLK to I2S_TXD/I2S_TX_FS output invalid	0	—	ns

Table continues on the next page...

Table 50. I2S/SAI slave mode timing in VLPR, VLPW, and VLPS modes (full voltage range) (continued)

Num.	Characteristic	Min.	Max.	Unit
S17	I2S_RXD setup before I2S_RX_BCLK	30	—	ns
S18	I2S_RXD hold after I2S_RX_BCLK	4	—	ns
S19	I2S_TX_FS input assertion to I2S_TXD output valid ¹	—	72	ns

1. Applies to first bit in each frame and only if the TCR4[FSE] bit is clear

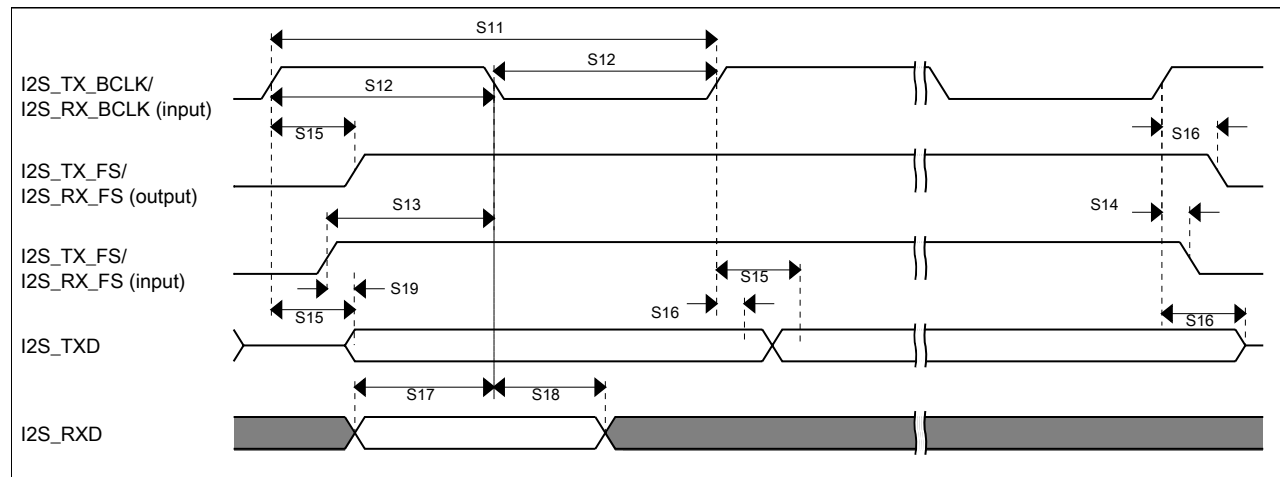
**Figure 31. I2S/SAI timing — slave modes**

4 Dimensions

4.1 Obtaining package dimensions

Package dimensions are provided in package drawings.

To find a package drawing, go to nxp.com and perform a keyword search for the drawing's document number:

If you want the drawing for this package	Then use this document number
64-pin LQFP	98ASS23234W
64-pin MAPBGA	98ASA00420D
88-pin QFN	98ASA00935D
100-pin LQFP	98ASS23308W
121-pin XFBGA	98ASA00595D

5 Pinout

5.1 K22F Signal Multiplexing and Pin Assignments

The following table shows the signals available on each pin and the locations of these pins on the devices supported by this document. The Port Control Module is responsible for selecting which ALT functionality is available on each pin.

NOTE

The MK22FN512VFX12 (88QFN) does not support the FlexBus function.

64 MAP BGA	64 LQFP	88 QFN	100 LQFP	121 XFPB GA	Pin Name	Default	ALT0	ALT1	ALT2	ALT3	ALT4	ALT5	ALT6	ALT7	EZPORT
A1	1	1	1	E4	PTE0/ CLKOUT3 2K	ADC1_ SE4a	ADC1_ SE4a	PTE0/ CLKOUT3 2K	SPI1_ PCS1	UART1_ TX			I2C1_SDA	RTC_ CLKOUT	
B1	2	2	2	E3	PTE1/ LLWU_P0	ADC1_ SE5a	ADC1_ SE5a	PTE1/ LLWU_P0	SPI1_ SOUT	UART1_ RX			I2C1_SCL	SPI1_SIN	
—	—	3	3	E2	PTE2/ LLWU_P1	ADC1_ SE6a	ADC1_ SE6a	PTE2/ LLWU_P1	SPI1_SCK	UART1_ CTS_b					
—	—	4	4	F4	PTE3	ADC1_ SE7a	ADC1_ SE7a	PTE3	SPI1_SIN	UART1_ RTS_b				SPI1_ SOUT	
—	—	5	5	H7	PTE4/ LLWU_P2	DISABLED		PTE4/ LLWU_P2	SPI1_ PCS0	LPUART0_ TX					
—	—	6	6	G4	PTE5	DISABLED		PTE5	SPI1_ PCS2	LPUART0_ RX			FTM3_ CH0		
—	—	7	7	F3	PTE6	DISABLED		PTE6	SPI1_ PCS3	LPUART0_ CTS_b	I2S0_ MCLK		FTM3_ CH1	USB_ SOF_OUT	
C5	3	8	8	E6	VDD	VDD	VDD								
C4	4	9	9	G7	VSS	VSS	VSS								
—	—	9	—	L6	VSS	VSS	VSS								
E1	5	10	10	F1	USB0_DP	USB0_DP	USB0_DP								
D1	6	11	11	F2	USB0_DM	USB0_DM	USB0_DM								
E2	7	12	12	G1	VOUT33	VOUT33	VOUT33								
D2	8	13	13	G2	VREGIN	VREGIN	VREGIN								
—	—	—	14	H1	ADC0_ DP1	ADC0_ DP1	ADC0_ DP1								
—	—	—	15	H2	ADC0_ DM1	ADC0_ DM1	ADC0_ DM1								

64 MAP BGA	64 LQFP	88 QFN	100 LQFP	121 XFPB GA	Pin Name	Default	ALT0	ALT1	ALT2	ALT3	ALT4	ALT5	ALT6	ALT7	EZPORT	
—	—	14	16	J1	ADC1_ DP1/ ADC0_ DP2	ADC1_ DP1/ ADC0_ DP2	ADC1_ DP1/ ADC0_ DP2									
—	—	15	17	J2	ADC1_ DM1/ ADC0_ DM2	ADC1_ DM1/ ADC0_ DM2	ADC1_ DM1/ ADC0_ DM2									
G1	9	16	18	K1	ADC0_ DP0/ ADC1_ DP3	ADC0_ DP0/ ADC1_ DP3	ADC0_ DP0/ ADC1_ DP3									
F1	10	17	19	K2	ADC0_ DM0/ ADC1_ DM3	ADC0_ DM0/ ADC1_ DM3	ADC0_ DM0/ ADC1_ DM3									
G2	11	—	20	L1	ADC1_ DP0/ ADC0_ DP3	ADC1_ DP0/ ADC0_ DP3	ADC1_ DP0/ ADC0_ DP3									
F2	12	—	21	L2	ADC1_ DM0/ ADC0_ DM3	ADC1_ DM0/ ADC0_ DM3	ADC1_ DM0/ ADC0_ DM3									
F4	13	18	22	F5	VDDA	VDDA	VDDA									
G4	14	19	23	G5	VREFH	VREFH	VREFH									
G3	15	20	24	G6	VREFL	VREFL	VREFL									
F3	16	21	25	F6	VSSA	VSSA	VSSA									
—	—	—	—	J3	ADC1_ SE16/ ADC0_ SE22	ADC1_ SE16/ ADC0_ SE22	ADC1_ SE16/ ADC0_ SE22									
—	—	—	—	H3	ADC0_ SE16/ CMP1_ IN2/ ADC0_ SE21	ADC0_ SE16/ CMP1_ IN2/ ADC0_ SE21	ADC0_ SE16/ CMP1_ IN2/ ADC0_ SE21									
H1	17	22	26	L3	VREF_ OUT/ CMP1_ IN5/ CMP0_ IN5/ ADC1_ SE18	VREF_ OUT/ CMP1_ IN5/ CMP0_ IN5/ ADC1_ SE18	VREF_ OUT/ CMP1_ IN5/ CMP0_ IN5/ ADC1_ SE18									
H2	18	23	27	K5	DAC0_ OUT/ CMP1_	DAC0_ OUT/ CMP1_	DAC0_ OUT/ CMP1_									

Pinout

64 MAP BGA	64 LQFP	88 QFN	100 LQFP	121 XFPB GA	Pin Name	Default	ALT0	ALT1	ALT2	ALT3	ALT4	ALT5	ALT6	ALT7	EZPORT
					IN3/ ADC0_SE23	IN3/ ADC0_SE23	IN3/ ADC0_SE23								
—	—	—	—	K4	DAC1_OUT/ CMP0_IN4/ ADC1_SE23	DAC1_OUT/ CMP0_IN4/ ADC1_SE23	DAC1_OUT/ CMP0_IN4/ ADC1_SE23								
—	—	—	—	L7	RTC_WAKEUP_B	RTC_WAKEUP_B	RTC_WAKEUP_B								
H3	19	24	28	L4	XTAL32	XTAL32	XTAL32								
H4	20	25	29	L5	EXTAL32	EXTAL32	EXTAL32								
H5	21	26	30	K6	VBAT	VBAT	VBAT								
—	—	—	31	H5	PTE24	ADC0_SE17	ADC0_SE17	PTE24				I2C0_SCL	EWM_OUT_b		
—	—	—	32	J5	PTE25	ADC0_SE18	ADC0_SE18	PTE25				I2C0_SDA	EWM_IN		
—	—	—	33	H6	PTE26/ CLKOUT3 2K	DISABLED		PTE26/ CLKOUT3 2K					RTC_CLKOUT	USB_CLKIN	
D3	22	27	34	J6	PTA0	JTAG_TCLK/ SWD_CLK/ EZP_CLK		PTA0	UART0_CTS_b	FTM0_CH5				JTAG_TCLK/ SWD_CLK	EZP_CLK
D4	23	28	35	H8	PTA1	JTAG_TDI/ EZP_DI		PTA1	UART0_RX	FTM0_CH6				JTAG_TDI	EZP_DI
E5	24	29	36	J7	PTA2	JTAG_TDO/ TRACE_SWO/ EZP_DO		PTA2	UART0_TX	FTM0_CH7				JTAG_TDO/ TRACE_SWO	EZP_DO
D5	25	30	37	H9	PTA3	JTAG_TMS/ SWD_DIO		PTA3	UART0_RTS_b	FTM0_CH0				JTAG_TMS/ SWD_DIO	
G5	26	31	38	J8	PTA4/ LLWU_P3	NMI_b/ EZP_CS_b		PTA4/ LLWU_P3		FTM0_CH1				NMI_b	EZP_CS_b
F5	27	32	39	K7	PTA5	DISABLED		PTA5	USB_CLKIN	FTM0_CH2			I2S0_TX_BCLK	JTAG_TRST_b	
—	—	33	40	E5	VDD	VDD	VDD								
—	—	34	41	G3	VSS	VSS	VSS								
—	—	—	—	J9	PTA10	DISABLED		PTA10		FTM2_CH0			FTM2_QD_PHA		
—	—	—	—	J4	PTA11	DISABLED		PTA11		FTM2_CH1			FTM2_QD_PHB		

64 MAP BGA	64 LQFP	88 QFN	100 LQFP	121 XFPB GA	Pin Name	Default	ALT0	ALT1	ALT2	ALT3	ALT4	ALT5	ALT6	ALT7	EZPORT
H6	28	35	42	K8	PTA12	DISABLED		PTA12		FTM1_ CH0			I2S0_ TXD0	FTM1_ QD_PHA	
G6	29	36	43	L8	PTA13/ LLWU_P4	DISABLED		PTA13/ LLWU_P4		FTM1_ CH1			I2S0_TX_ FS	FTM1_ QD_PHB	
—	—	37	44	K9	PTA14	DISABLED		PTA14	SPI0_ PCS0	UART0_ TX			I2S0_RX_ BCLK		
—	—	38	45	L9	PTA15	DISABLED		PTA15	SPI0_SCK	UART0_ RX			I2S0_ RXD0		
—	—	39	46	J10	PTA16	DISABLED		PTA16	SPI0_ SOUT	UART0_ CTS_b			I2S0_RX_ FS		
—	—	40	47	H10	PTA17	ADC1_ SE17	ADC1_ SE17	PTA17	SPI0_SIN	UART0_ RTS_b			I2S0_ MCLK		
G7	30	41	48	L10	VDD	VDD	VDD								
H7	31	42	49	K10	VSS	VSS	VSS								
H8	32	43	50	L11	PTA18	EXTAL0	EXTAL0	PTA18		FTM0_ FLT2	FTM_ CLKIN0				
G8	33	44	51	K11	PTA19	XTAL0	XTAL0	PTA19		FTM1_ FLT0	FTM_ CLKIN1		LPTMR0_ ALT1		
F8	34	45	52	J11	RESET_b	RESET_b	RESET_b								
—	—	—	—	H11	PTA29	DISABLED		PTA29					FB_A24		
F7	35	46	53	G11	PTB0/ LLWU_P5	ADC0_ SE8/ ADC1_ SE8	ADC0_ SE8/ ADC1_ SE8	PTB0/ LLWU_P5	I2C0_SCL	FTM1_ CH0			FTM1_ QD_PHA		
F6	36	47	54	G10	PTB1	ADC0_ SE9/ ADC1_ SE9	ADC0_ SE9/ ADC1_ SE9	PTB1	I2C0_SDA	FTM1_ CH1			FTM1_ QD_PHB		
E7	37	48	55	G9	PTB2	ADC0_ SE12	ADC0_ SE12	PTB2	I2C0_SCL	UART0_ RTS_b			FTM0_ FLT3		
E8	38	49	56	G8	PTB3	ADC0_ SE13	ADC0_ SE13	PTB3	I2C0_SDA	UART0_ CTS_b			FTM0_ FLT0		
—	—	50	—	F11	PTB6	ADC1_ SE12	ADC1_ SE12	PTB6				FB_AD23			
—	—	51	—	E11	PTB7	ADC1_ SE13	ADC1_ SE13	PTB7				FB_AD22			
—	—	52	—	D11	PTB8	DISABLED		PTB8		LPUART0_ RTS_b		FB_AD21			
—	—	53	57	E10	PTB9	DISABLED		PTB9	SPI1_ PCS1	LPUART0_ CTS_b		FB_AD20			
—	—	54	58	D10	PTB10	ADC1_ SE14	ADC1_ SE14	PTB10	SPI1_ PCS0	LPUART0_ RX		FB_AD19	FTM0_ FLT1		
—	—	55	59	C10	PTB11	ADC1_ SE15	ADC1_ SE15	PTB11	SPI1_SCK	LPUART0_ TX		FB_AD18	FTM0_ FLT2		
—	—	—	60	—	VSS	VSS	VSS								

Pinout

64 MAP BGA	64 LQFP	88 QFN	100 LQFP	121 XFPB GA	Pin Name	Default	ALT0	ALT1	ALT2	ALT3	ALT4	ALT5	ALT6	ALT7	EZPORT
—	—	—	61	—	VDD	VDD	VDD								
E6	39	56	62	B10	PTB16	DISABLED		PTB16	SPI1_ SOUT	UART0_ RX	FTM_ CLKIN0	FB_AD17	EWM_IN		
D7	40	57	63	E9	PTB17	DISABLED		PTB17	SPI1_ SIN	UART0_ TX	FTM_ CLKIN1	FB_AD16	EWM_ OUT_b		
D6	41	58	64	D9	PTB18	DISABLED		PTB18		FTM2_ CH0	I2S0_TX_ BCLK	FB_AD15	FTM2_ QD_PHA		
C7	42	59	65	C9	PTB19	DISABLED		PTB19		FTM2_ CH1	I2S0_TX_ FS	FB_OE_b	FTM2_ QD_PHB		
—	—	—	66	F10	PTB20	DISABLED		PTB20				FB_AD31	CMP0_ OUT		
—	—	—	67	F9	PTB21	DISABLED		PTB21				FB_AD30	CMP1_ OUT		
—	—	—	68	F8	PTB22	DISABLED		PTB22				FB_AD29			
—	—	—	69	E8	PTB23	DISABLED		PTB23		SPI0_ PCS5		FB_AD28			
D8	43	60	70	B9	PTC0	ADC0_ SE14	ADC0_ SE14	PTC0	SPI0_ PCS4	PDB0_ EXTRG	USB_ SOF_OUT	FB_AD14			
C6	44	61	71	D8	PTC1/ LLWU_P6	ADC0_ SE15	ADC0_ SE15	PTC1/ LLWU_P6	SPI0_ PCS3	UART1_ RTS_b	FTM0_ CH0	FB_AD13	I2S0_ TXD0	LPUART0_ RTS_b	
B7	45	62	72	C8	PTC2	ADC0_ SE4b/ CMP1_IN0	ADC0_ SE4b/ CMP1_IN0	PTC2	SPI0_ PCS2	UART1_ CTS_b	FTM0_ CH1	FB_AD12	I2S0_TX_ FS	LPUART0_ CTS_b	
C8	46	63	73	B8	PTC3/ LLWU_P7	CMP1_IN1	CMP1_IN1	PTC3/ LLWU_P7	SPI0_ PCS1	UART1_ RX	FTM0_ CH2	CLKOUT	I2S0_TX_ BCLK	LPUART0_ RX	
E3	47	64	74	—	VSS	VSS	VSS								
E4	48	65	75	—	VDD	VDD	VDD								
B8	49	66	76	A8	PTC4/ LLWU_P8	DISABLED		PTC4/ LLWU_P8	SPI0_ PCS0	UART1_ TX	FTM0_ CH3	FB_AD11	CMP1_ OUT	LPUART0_ TX	
A8	50	67	77	D7	PTC5/ LLWU_P9	DISABLED		PTC5/ LLWU_P9	SPI0_ SCK	LPTMR0_ ALT2	I2S0_ RXD0	FB_AD10	CMP0_ OUT	FTM0_ CH2	
A7	51	68	78	C7	PTC6/ LLWU_ P10	CMP0_IN0	CMP0_IN0	PTC6/ LLWU_ P10	SPI0_ SOUT	PDB0_ EXTRG	I2S0_RX_ BCLK	FB_AD9	I2S0_ MCLK		
B6	52	69	79	B7	PTC7	CMP0_IN1	CMP0_IN1	PTC7	SPI0_ SIN	USB_ SOF_OUT	I2S0_RX_ FS	FB_AD8			
A6	53	70	80	A7	PTC8	ADC1_ SE4b/ CMP0_IN2	ADC1_ SE4b/ CMP0_IN2	PTC8		FTM3_ CH4	I2S0_ MCLK	FB_AD7			
B5	54	—	81	D6	PTC9	ADC1_ SE5b/ CMP0_IN3	ADC1_ SE5b/ CMP0_IN3	PTC9		FTM3_ CH5	I2S0_RX_ BCLK	FB_AD6	FTM2_ FLT0		
B4	55	—	82	C6	PTC10	ADC1_ SE6b	ADC1_ SE6b	PTC10	I2C1_ SCL	FTM3_ CH6	I2S0_RX_ FS	FB_AD5			

64 MAP BGA	64 LQFP	88 QFN	100 LQFP	121 XFPB GA	Pin Name	Default	ALT0	ALT1	ALT2	ALT3	ALT4	ALT5	ALT6	ALT7	EZPORT
A5	56	—	83	C5	PTC11/ LLWU_ P11	ADC1_ SE7b	ADC1_ SE7b	PTC11/ LLWU_ P11	I2C1_SDA	FTM3_ CH7		FB_RW_b			
—	—	71	84	B6	PTC12	DISABLED		PTC12				FB_AD27	FTM3_ FLT0		
—	—	72	85	A6	PTC13	DISABLED		PTC13				FB_AD26			
—	—	73	86	A5	PTC14	DISABLED		PTC14				FB_AD25			
—	—	74	87	B5	PTC15	DISABLED		PTC15				FB_AD24			
—	—	—	88	—	VSS	VSS	VSS								
—	—	—	89	—	VDD	VDD	VDD								
—	—	75	90	D5	PTC16	DISABLED		PTC16		LPUART0_ RX		FB_CS5_ b/ FB_TSIZ1/ FB_BE23_ 16_ BLS15_8_ b			
—	—	76	91	C4	PTC17	DISABLED		PTC17		LPUART0_ TX		FB_CS4_ b/ FB_TSIZ0/ FB_BE31_ 24_BLS7_ 0_b			
—	—	77	92	B4	PTC18	DISABLED		PTC18		LPUART0_ RTS_b		FB_TBST_ b/ FB_CS2_ b/ FB_BE15_ 8_BLS23_ 16_b			
—	—	78	—	A4	PTC19	DISABLED		PTC19		LPUART0_ CTS_b		FB_CS3_ b/ FB_BE7_ 0_BLS31_ 24_b	FB_TA_b		
C3	57	79	93	D4	PTD0/ LLWU_ P12	DISABLED		PTD0/ LLWU_ P12	SPI0_ PCS0	UART2_ RTS_b	FTM3_ CH0	FB_ALE/ FB_CS1_ b/ FB_TS_b	LPUART0_ RTS_b		
A4	58	80	94	D3	PTD1	ADC0_ SE5b	ADC0_ SE5b	PTD1	SPI0_SCK	UART2_ CTS_b	FTM3_ CH1	FB_CS0_b	LPUART0_ CTS_b		
C2	59	81	95	C3	PTD2/ LLWU_ P13	DISABLED		PTD2/ LLWU_ P13	SPI0_ SOUT	UART2_ RX	FTM3_ CH2	FB_AD4	LPUART0_ RX	I2C0_SCL	
B3	60	82	96	B3	PTD3	DISABLED		PTD3	SPI0_SIN	UART2_ TX	FTM3_ CH3	FB_AD3	LPUART0_ TX	I2C0_SDA	

Pinout

64 MAP BGA	64 LQFP	88 QFN	100 LQFP	121 XFPB GA	Pin Name	Default	ALT0	ALT1	ALT2	ALT3	ALT4	ALT5	ALT6	ALT7	EZPORT
A3	61	83	97	A3	PTD4/LLWU_P14	DISABLED		PTD4/LLWU_P14	SPI0_PCS1	UART0_RTS_b	FTM0_CH4	FB_AD2	EWM_IN	SPI1_PCS0	
C1	62	84	98	A2	PTD5	ADC0_SE6b	ADC0_SE6b	PTD5	SPI0_PCS2	UART0_CTS_b	FTM0_CH5	FB_AD1	EWM_OUT_b	SPI1_SCK	
—	—	85	—	F7	VSS	VSS	VSS								
—	—	86	—	E7	VDD	VDD	VDD								
B2	63	87	99	B2	PTD6/LLWU_P15	ADC0_SE7b	ADC0_SE7b	PTD6/LLWU_P15	SPI0_PCS3	UART0_RX	FTM0_CH6	FB_AD0	FTM0_FLT0	SPI1_SOUT	
A2	64	88	100	A1	PTD7	DISABLED		PTD7		UART0_TX	FTM0_CH7		FTM0_FLT1	SPI1_SIN	
—	—	—	—	A10	PTD8	DISABLED		PTD8	I2C0_SCL			LPUART0_RX	FB_A16		
—	—	—	—	A9	PTD9	DISABLED		PTD9	I2C0_SDA			LPUART0_TX	FB_A17		
—	—	—	—	B1	PTD10	DISABLED		PTD10				LPUART0_RTS_b	FB_A18		
—	—	—	—	C2	PTD11	DISABLED		PTD11				LPUART0_CTS_b	FB_A19		
—	—	—	—	C1	PTD12	DISABLED		PTD12		FTM3_FLT0			FB_A20		
—	—	—	—	D2	PTD13	DISABLED		PTD13					FB_A21		
—	—	—	—	D1	PTD14	DISABLED		PTD14					FB_A22		
—	—	—	—	E1	PTD15	DISABLED		PTD15					FB_A23		
—	—	—	—	A11	NC	NC	NC								
—	—	—	—	K3	NC	NC	NC								
—	—	—	—	H4	NC	NC	NC								
—	—	—	—	B11	NC	NC	NC								
—	—	—	—	C11	NC	NC	NC								

5.2 Recommended connection for unused analog and digital pins

The following table shows the recommended connections for analog interface pins if those analog interfaces are not used in the customer's application.

Table 51. Recommended connection for unused analog interfaces

Pin Type		Short recommendation	Detailed recommendation
Analog/non GPIO	PGAx/ADCx	Float	Analog input - Float
Analog/non GPIO	ADCx/CMPx	Float	Analog input - Float

Table continues on the next page...

Table 51. Recommended connection for unused analog interfaces (continued)

Pin Type		Short recommendation	Detailed recommendation
Analog/non GPIO	VREF_OUT	Float	Analog output - Float
Analog/non GPIO	DACx_OUT	Float	Analog output - Float
Analog/non GPIO	RTC_WAKEUP_B	Float	Analog output - Float
Analog/non GPIO	XTAL32	Float	Analog output - Float
Analog/non GPIO	EXTAL32	Float	Analog input - Float
GPIO/Analog	PTA18/EXTAL0	Float	Analog input - Float
GPIO/Analog	PTA19/XTAL0	Float	Analog output - Float
GPIO/Analog	PTx/ADCx	Float	Float (default is analog input)
GPIO/Analog	PTx/CMPx	Float	Float (default is analog input)
GPIO/Digital	PTA0/JTAG_TCLK	Float	Float (default is JTAG with pulldown)
GPIO/Digital	PTA1/JTAG_TDI	Float	Float (default is JTAG with pullup)
GPIO/Digital	PTA2/JTAG_TDO	Float	Float (default is JTAG with pullup)
GPIO/Digital	PTA3/JTAG_TMS	Float	Float (default is JTAG with pullup)
GPIO/Digital	PTA4/NMI_b	10k Ω pullup or disable and float	Pull high or disable in PCR & FOPT and float
GPIO/Digital	PTx	Float	Float (default is disabled)
USB	USB0_DP	Float	Float
USB	USB0_DM	Float	Float
USB	VOUT33	Tie to input and ground through 10k Ω	Tie to input and ground through 10k Ω
USB	VREGIN	Tie to output and ground through 10k Ω	Tie to output and ground through 10k Ω
VBAT	VBAT	Float	Float
VDDA	VDDA	Always connect to VDD potential	Always connect to VDD potential
VREFH	VREFH	Always connect to VDD potential	Always connect to VDD potential
VREFL	VREFL	Always connect to VSS potential	Always connect to VSS potential
VSSA	VSSA	Always connect to VSS potential	Always connect to VSS potential

5.3 K22 Pinouts

The following figure shows the pinout diagram for the devices supported by this document. Many signals may be multiplexed onto a single pin. To determine what signals can be used on which pin, see the previous section.

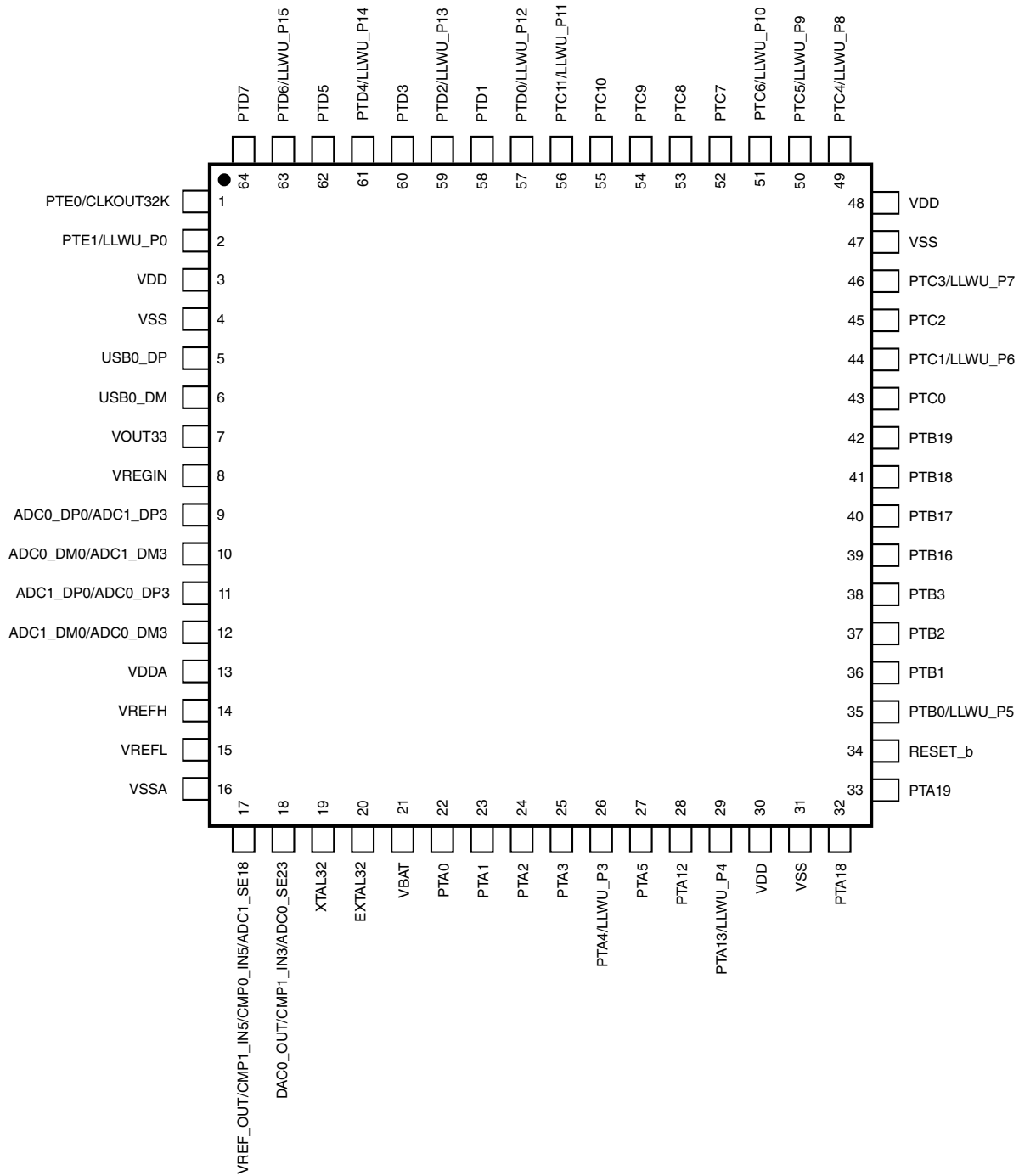

Figure 32. K22F 64 LQFP pinout diagram (top view)

	1	2	3	4	5	6	7	8	
A	PTE0/ CLKOUT32K	PTD7	PTD4/ LLWU_P14	PTD1	PTC11/ LLWU_P11	PTC8	PTC6/ LLWU_P10	PTC5/ LLWU_P9	A
B	PTE1/ LLWU_P0	PTD6/ LLWU_P15	PTD3	PTC10	PTC9	PTC7	PTC2	PTC4/ LLWU_P8	B
C	PTD5	PTD2/ LLWU_P13	PTD0/ LLWU_P12	VSS	VDD	PTC1/ LLWU_P6	PTB19	PTC3/ LLWU_P7	C
D	USB0_DM	VREGIN	PTA0	PTA1	PTA3	PTB18	PTB17	PTC0	D
E	USB0_DP	VOOUT33	VSS	VDD	PTA2	PTB16	PTB2	PTB3	E
F	ADC0_DM0/ ADC1_DM3	ADC1_DM0/ ADC0_DM3	VSSA	VDDA	PTA5	PTB1	PTB0/ LLWU_P5	RESET_b	F
G	ADC0_DP0/ ADC1_DP3	ADC1_DP0/ ADC0_DP3	VREFL	VREFH	PTA4/ LLWU_P3	PTA13/ LLWU_P4	VDD	PTA19	G
H	VREF_OUT/ CMP1_IN5/ CMP0_IN5/ ADC1_SE18	DAC0_OUT/ CMP1_IN3/ ADC0_SE23	XTAL32	EXTAL32	VBAT	PTA12	VSS	PTA18	H
	1	2	3	4	5	6	7	8	

Figure 33. K22F 64 MAPBGA pinout diagram (transparent top view)

Pinout

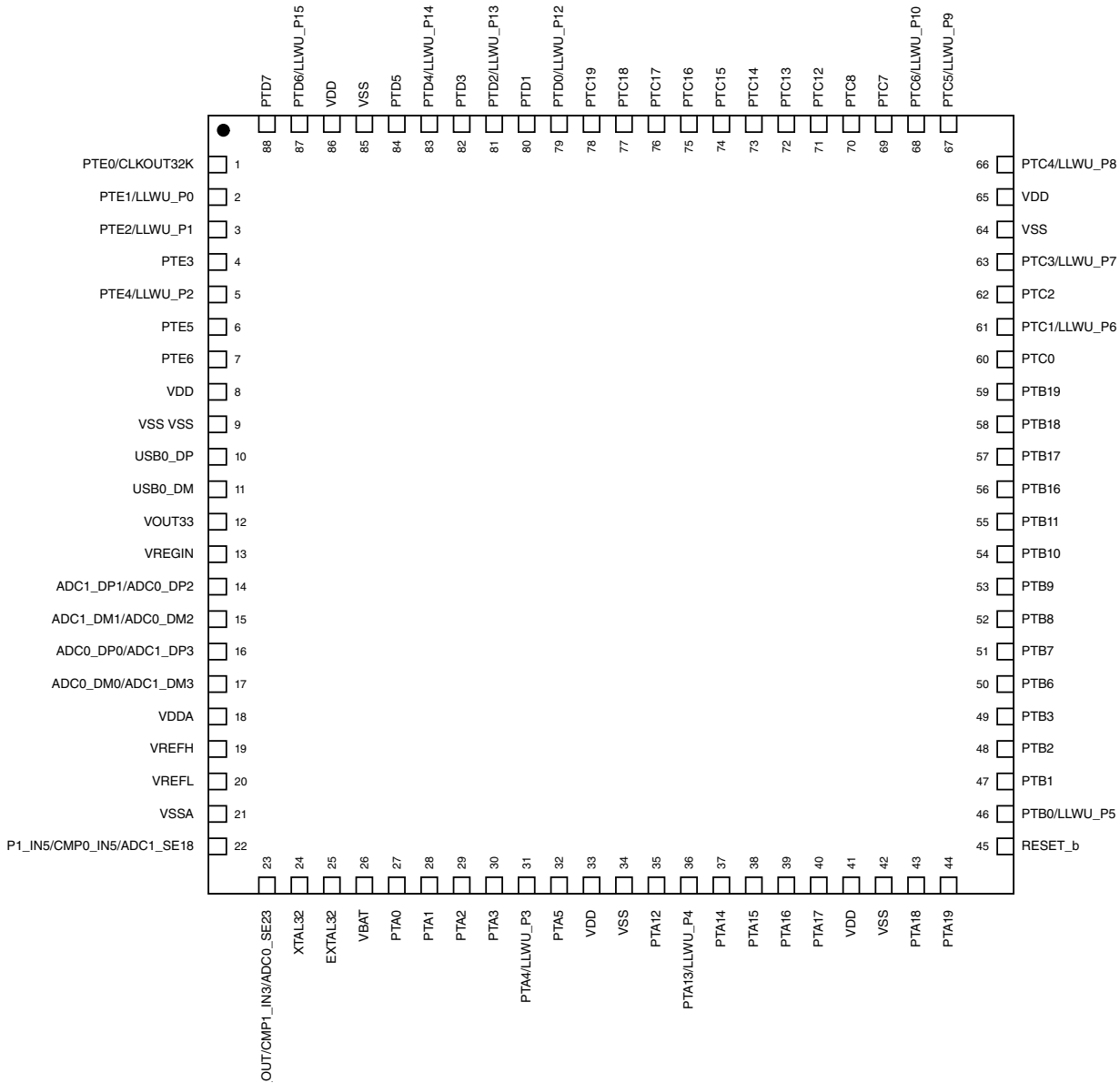

Figure 34. K22F 88 QFN pinout diagram (transparent top view)

NOTE

For more information about QFN package use, see [Electrical Connection Recommendations for the Exposed Pad on QFN and DFN Packages](#) .

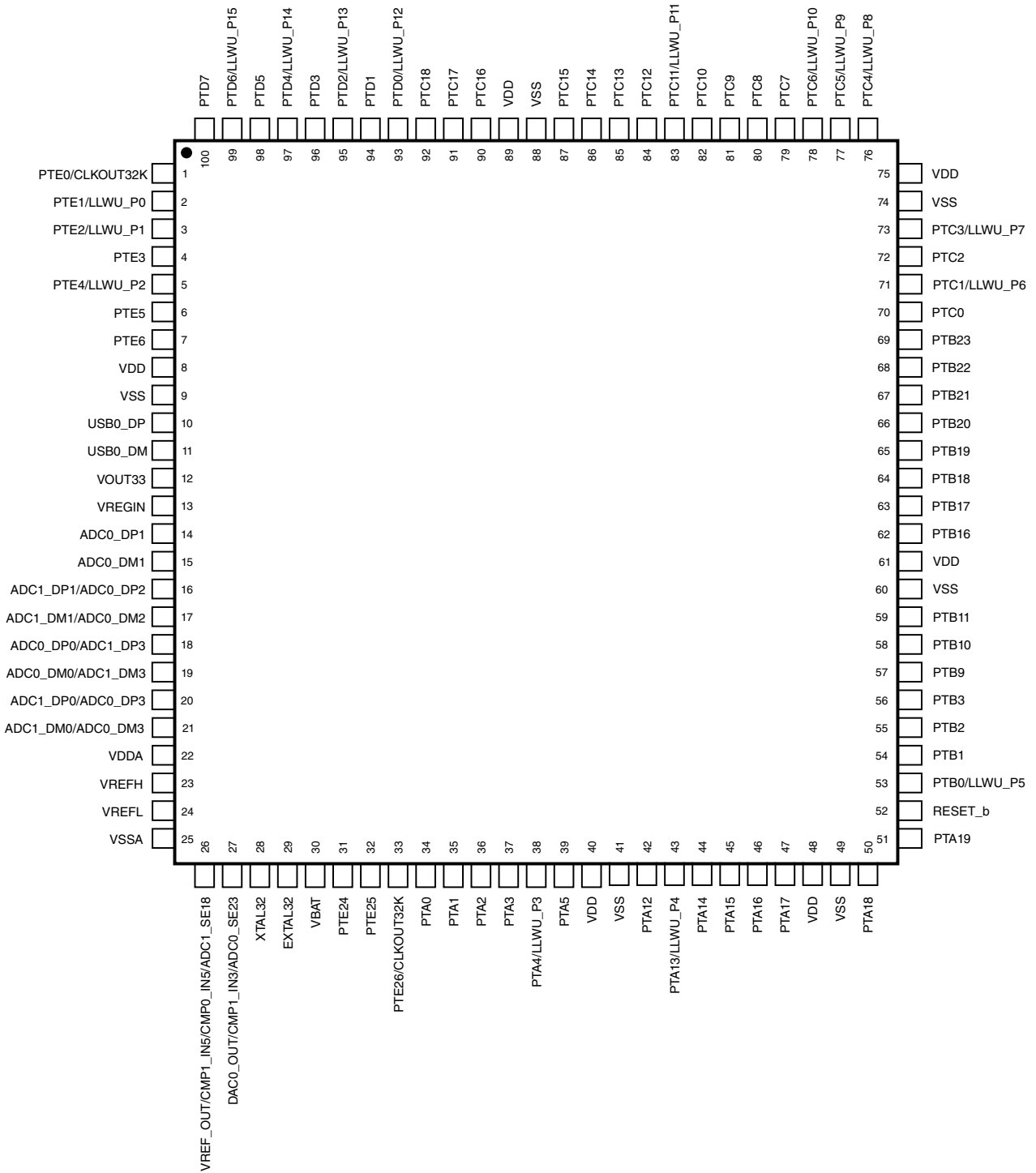

Figure 35. K22F 100 LQFP pinout diagram (top view)

Part identification

	1	2	3	4	5	6	7	8	9	10	11	
A	PTD7	PTD5	PTD4/ LLWU_P14	PTC19	PTC14	PTC13	PTC8	PTC4/ LLWU_P8	PTD9	PTD8	NC	A
B	PTD10	PTD6/ LLWU_P15	PTD3	PTC18	PTC15	PTC12	PTC7	PTC3/ LLWU_P7	PTC0	PTB16	NC	B
C	PTD12	PTD11	PTD2/ LLWU_P13	PTC17	PTC11/ LLWU_P11	PTC10	PTC6/ LLWU_P10	PTC2	PTB19	PTB11	NC	C
D	PTD14	PTD13	PTD1	PTD0/ LLWU_P12	PTC16	PTC9	PTC5/ LLWU_P9	PTC1/ LLWU_P6	PTB18	PTB10	PTB8	D
E	PTD15	PTE2/ LLWU_P1	PTE1/ LLWU_P0	PTE0/ CLKOUT32K	VDD	VDD	VDD	PTB23	PTB17	PTB9	PTB7	E
F	USB0_DP	USB0_DM	PTE6	PTE3	VDDA	VSSA	VSS	PTB22	PTB21	PTB20	PTB6	F
G	VOUT33	VREGIN	VSS	PTE5	VREFH	VREFL	VSS	PTB3	PTB2	PTB1	PTB0/ LLWU_P5	G
H	ADC0_DP1	ADC0_DM1	ADC0_SE16/ CMP1_IN2/ ADC0_SE21	NC	PTE24	PTE26/ CLKOUT32K	PTE4/ LLWU_P2	PTA1	PTA3	PTA17	PTA29	H
J	ADC1_DP1/ ADC0_DP2	ADC1_DM1/ ADC0_DM2	ADC1_SE16/ ADC0_SE22	PTA11	PTE25	PTA0	PTA2	PTA4/ LLWU_P3	PTA10	PTA16	RESET_b	J
K	ADC0_DP0/ ADC1_DP3	ADC0_DM0/ ADC1_DM3	NC	DAC1_OUT/ CMP0_IN4/ ADC1_SE23	DAC0_OUT/ CMP1_IN3/ ADC0_SE23	VBAT	PTA5	PTA12	PTA14	VSS	PTA19	K
L	ADC1_DP0/ ADC0_DP3	ADC1_DM0/ ADC0_DM3	VREF_OUT/ CMP1_IN5/ CMP0_IN5/ ADC1_SE18	XTAL32	EXTAL32	VSS	RTC_ WAKEUP_B	PTA13/ LLWU_P4	PTA15	VDD	PTA18	L
	1	2	3	4	5	6	7	8	9	10	11	

Figure 36. K22F 121 XFBGA pinout diagram (transparent top view)

6 Part identification

6.1 Description

Part numbers for the chip have fields that identify the specific part. You can use the values of these fields to determine the specific part you have received.

6.2 Format

Part numbers for this device have the following format:

Q K## A M FFF R T PP CC N

6.3 Fields

This table lists the possible values for each field in the part number (not all combinations are valid):

Field	Description	Values
Q	Qualification status	<ul style="list-style-type: none"> • M = Fully qualified, general market flow, full reel • P = Prequalification • K = Fully qualified, general market flow, 100 piece reel
K##	Kinetis family	<ul style="list-style-type: none"> • K22
A	Key attribute	<ul style="list-style-type: none"> • D = Cortex-M4 w/ DSP • F = Cortex-M4 w/ DSP and FPU
M	Flash memory type	<ul style="list-style-type: none"> • N = Program flash only • X = Program flash and FlexMemory
FFF	Program flash memory size	<ul style="list-style-type: none"> • 128 = 128 KB • 256 = 256 KB • 512 = 512 KB
R	Silicon revision	<ul style="list-style-type: none"> • Z = Initial • (Blank) = Main • A = Revision after main
T	Temperature range (°C)	<ul style="list-style-type: none"> • V = -40 to 105 • C = -40 to 85
PP	Package identifier	<ul style="list-style-type: none"> • LH = 64 LQFP (10 mm x 10 mm) • MP = 64 MAPBGA (5 mm x 5 mm) • FX = 88 QFN (10mm x 10mm) • LL = 100 LQFP (14 mm x 14 mm) • MC = 121 XFBGA (8 mm x 8 mm) • DC = 121 XFBGA (8 mm x 8 mm x 0.5 mm)
CC	Maximum CPU frequency (MHz)	<ul style="list-style-type: none"> • 5 = 50 MHz • 7 = 72 MHz • 10 = 100 MHz • 12 = 120 MHz • 15 = 150 MHz
N	Packaging type	<ul style="list-style-type: none"> • R = Tape and reel

6.4 Example

This is an example part number:

MK22FN512VDC12

6.5 Package Markings

Package markings for Kinetis MCU devices consists of 3 sets of identifiers:

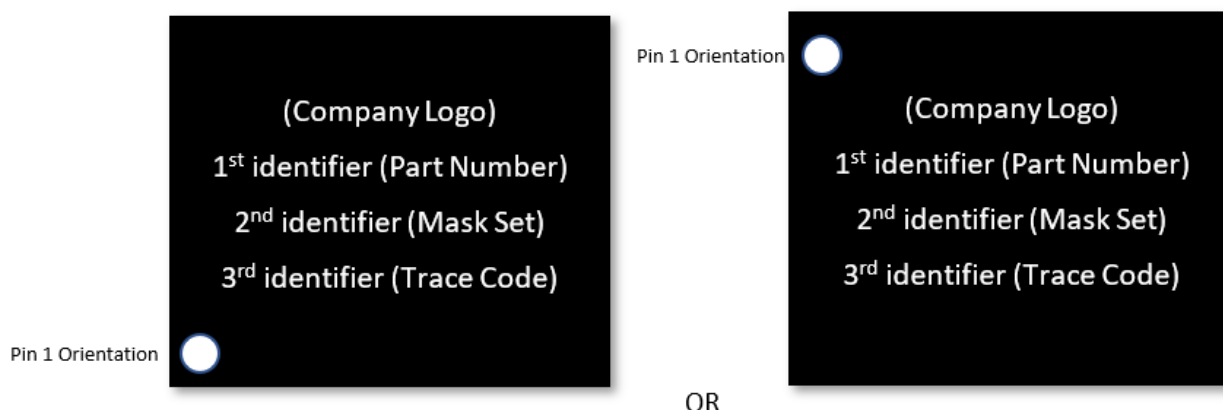

Figure 37. Package Marking

1st identifier defines the Part Number and is composed of at least 6 characters typically represented as one line. Part Number may wrap around to a second line if the package markings have 4 lines total.

2nd identifier defines the Mask Set and is composed of 5 characters.

3rd identifier defines the Trace Code used for traceability data and the Date Code for the week of manufacture is a subset of the standard 10 character format

- The standard trace code format is “xxxxYYWWx”:
 - The four leading digits and last one represented by an “x” can be ignored and “YYWW” indicate the Date Code
 - “YY” represents the last 2 digits of the calendar year (e.g: 18 corresponds to the year 2018)
 - “WW” represents the work week within the calendar year (e.g: 50 corresponds to week 50)
- If the Trace Code on your device consists of less than 10 characters or the package markings are different than what has outlined above, please contact your local NXP representative for further details

7 Terminology and guidelines

7.1 Definitions

Key terms are defined in the following table:

Term	Definition
Rating	<p>A minimum or maximum value of a technical characteristic that, if exceeded, may cause permanent chip failure:</p> <ul style="list-style-type: none"> • <i>Operating ratings</i> apply during operation of the chip. • <i>Handling ratings</i> apply when the chip is not powered. <p>NOTE: The likelihood of permanent chip failure increases rapidly as soon as a characteristic begins to exceed one of its operating ratings.</p>
Operating requirement	<p>A specified value or range of values for a technical characteristic that you must guarantee during operation to avoid incorrect operation and possibly decreasing the useful life of the chip</p>
Operating behavior	<p>A specified value or range of values for a technical characteristic that are guaranteed during operation if you meet the operating requirements and any other specified conditions</p>
Typical value	<p>A specified value for a technical characteristic that:</p> <ul style="list-style-type: none"> • Lies within the range of values specified by the operating behavior • Is representative of that characteristic during operation when you meet the typical-value conditions or other specified conditions <p>NOTE: Typical values are provided as design guidelines and are neither tested nor guaranteed.</p>

7.2 Examples

Operating rating:

Symbol	Description	Min.	Max.	Unit
V _{DD}	1.0 V core supply voltage	-0.3	1.2	V

Operating requirement:

Symbol	Description	Min.	Max.	Unit
V _{DD}	1.0 V core supply voltage	0.9	1.1	V

Operating behavior that includes a typical value:

Symbol	Description	Min.	Typ.	Max.	Unit
I _{WP}	Digital I/O weak pullup/pulldown current	10	70	130	μA

7.3 Typical-value conditions

Typical values assume you meet the following conditions (or other conditions as specified):

Symbol	Description	Value	Unit
T _A	Ambient temperature	25	°C
V _{DD}	Supply voltage	3.3	V

7.4 Relationship between ratings and operating requirements

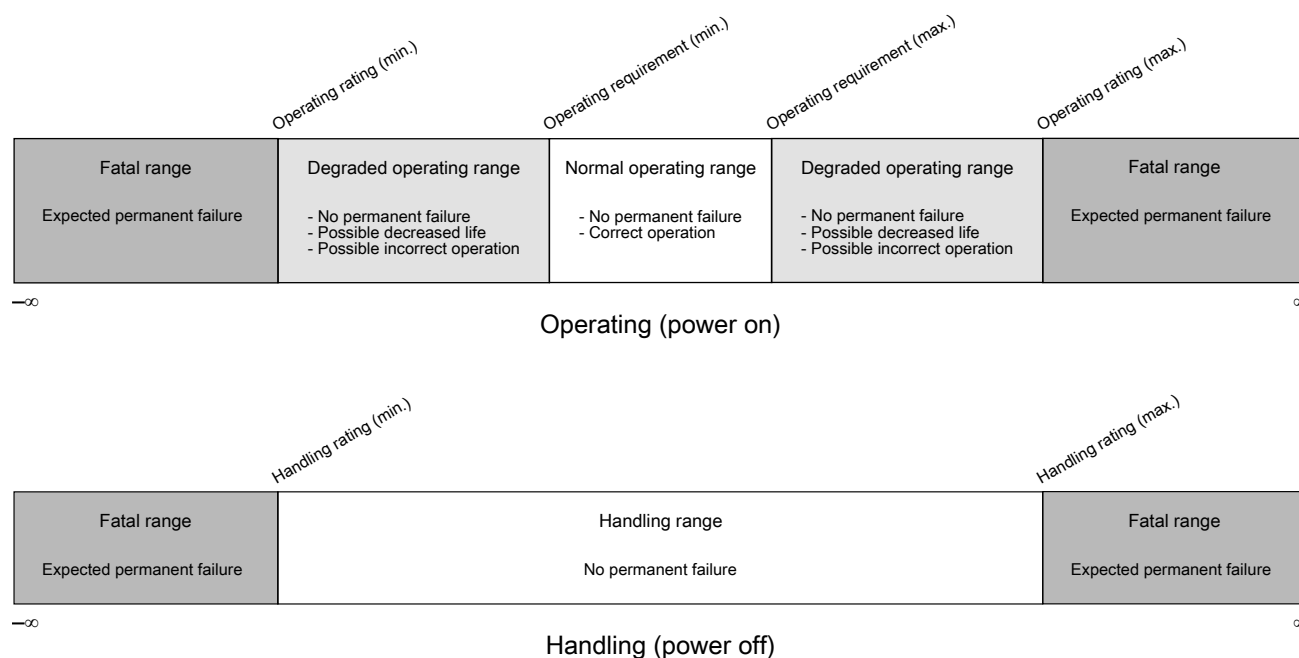

7.5 Guidelines for ratings and operating requirements

Follow these guidelines for ratings and operating requirements:

- Never exceed any of the chip's ratings.
- During normal operation, don't exceed any of the chip's operating requirements.
- If you must exceed an operating requirement at times other than during normal operation (for example, during power sequencing), limit the duration as much as possible.

8 Revision History

The following table provides a revision history for this document.

Table 52. Revision History

Rev. No.	Date	Substantial Changes
8	06/2023	<ul style="list-style-type: none"> • Updated the footnote in front matter to mention that only MK22FN512VDC12 (121 BGA) supports two DACs • Updated Voltage and current operating ratings • Added $V_{BAT:SRPWRIN}$ in Table 1

Table continues on the next page...

Table 52. Revision History (continued)

Rev. No.	Date	Substantial Changes
		<ul style="list-style-type: none"> Updated footnote attached to Reference Voltage in 12-bit DAC operating requirements Updated from 121 MAPBGA to 121 XFBGA in K22 F pinout table Updated footnote in frontmatter to state "Only MK22FN512VDC12 (121BGA) supports both DAC : DAC0 and DAC1" Updated Ordering information table in Front Matter by adding Part number marking and packages column Removed 121-pin XFBGA part marking and 64-pin MAPBGA part marking sections. Added generic Package Markings section Updated ADC frequencies at different modes in 16-bit ADC operating conditions Updated package drawing links in Front Matter Content and Obtaining package dimensions
7.1	08/2016	<ul style="list-style-type: none"> Removed the footnote "Information related to the 88 QFN package is preliminary" in front matter Added Engineering Bulletin in Related Resource table Updated the Front Matter by adding footnotes Added Terminology and Guidelines section Added Device Revision Number Table Updated Chip Errata naming convention in Related Resource table
7	11/2015	<ul style="list-style-type: none"> Added information related 88 QFN package
6	10/2015	<ul style="list-style-type: none"> In "Power consumption operating behaviors" section, added "Low power mode peripheral adders—typical value" table In "Thermal operating requirements" table, in footnote, corrected "$T_J = T_A + \Theta_{JA}$" to "$T_J = T_A + R_{\Theta JA}$" Updated "IRC48M specifications" table Updated "NVM program/erase timing specifications" table; removed row for $t_{hversall}$ and added row for $t_{hversblk256k}$ Updated "Flash command timing specifications" table; added rows for $t_{rd1blk256k}$ and $t_{ersblk256k}$ In "Slave mode DSPI timing (limited voltage range)" table, added footnote regarding maximum frequency of operation Added new section, "Recommended connections for unused analog and digital pins"
5	4/2015	<ul style="list-style-type: none"> On page 1: <ul style="list-style-type: none"> Added the certified USB-IF Logo In first bullet of introduction, updated power consumption data to align with the data in the "Power consumption operating behaviors" table In second bullet of introduction, added "USB FS device crystal-less functionality" Under "Security and integrity modules" added "Hardware random-number generator" Under "Communication interfaces," updated I²C bullet to indicate support for up to 1 Mbps operation Under "Operating characteristics," specified that voltage range includes flash writes In figure, "Functional block diagram," added "Random-number generator." In "Voltage and current operating requirements" table: <ul style="list-style-type: none"> Removed content related to positive injection Updated footnote 1 to say that all analog and I/O pins are internally clamped to V_{SS} only (not V_{SS} and V_{DD}) through ESD protection diodes. In "Power consumption operating behaviors" table:

Table continues on the next page...

Table 52. Revision History (continued)

Rev. No.	Date	Substantial Changes
		<ul style="list-style-type: none"> • Added additional temperature data in power consumption table • Added Max IDD values based on characterization results equivalent to mean + 3 sigma • Updated "EMC radiated emissions operating behaviors" table • In "Thermal operating requirements" table, added the following footnote for ambient temperature: "Maximum T_A can be exceeded only if the user ensures that T_J does not exceed maximum T_J. The simplest method to determine T_J is: $T_J = T_A + \Theta_{JA} \times$ chip power dissipation" • Updated "IRC48M Specifications": <ul style="list-style-type: none"> • Updated maximum values for $\Delta_{firc48m_ol_lv}$ and $\Delta_{firc48m_ol_hv}$ (full temperature) • Added specifications for $\Delta_{firc48m_ol_hv}$ (-40°C to 85°C) • Updated notes in "USB electrical specifications" section • In "I²C timing" table, <ul style="list-style-type: none"> • Added the following footnote on maximum Fast mode value for SCL Clock Frequency: "The maximum SCL Clock Frequency in Fast mode with maximum bus loading can only be achieved when using the High drive pins across the full voltage range and when using the Normal drive pins and VDD ≥ 2.7 V." • Updated minimum Fast mode value for LOW period of the SCL clock to 1.25 μ • Added "I²C 1 Mbps timing" table • Removed Section 6, "Ordering parts." • Specified that the figure, "K22F 64 LQFP Pinout Diagram" is a top view • Specified that the figure, "K22F 64 MAPBGA Pinout Diagram" is a transparent top view • Specified that the figure, "K22F 100 LQFP Pinout Diagram" is a top view • Corrected part marking shown in "64-pin MAPBGA part marking" table
4	7/2014	<ul style="list-style-type: none"> • In "Power consumption operating behaviors table": <ul style="list-style-type: none"> • Updated existing typical power measurements • Added new typical power measurements for the following: <ul style="list-style-type: none"> • IDD_HSRUN (High Speed Run mode current executing CoreMark code) • IDD_RUNCO (Run mode current in Compute operation, executing CoreMark code) • IDD_RUN (Run mode current in Compute operation, executing while(1) loop) • IDD_VLPR (Very Low Power mode current executing CoreMark code) • IDD_VLPR (Very Low Power Run mode current in Compute operation, executing while(1) loop) • In "Thermal attributes" table, added values for 64 MAPBGA package
3	5/2014	<ul style="list-style-type: none"> • In "Voltage and current operating ratings" table, updated maximum digital supply current • Updated "Voltage and current operating behaviors" table • Updated "Power mode transition operating behaviors" table • Updated "Power consumption operating behaviors" table • Updated "EMC radiated emissions operating behaviors for 64 LQFP package" table • Updated "Thermal attributes" table • Updated "MCG specifications" table • Updated "IRC48M specifications" table • Updated "16-bit ADC operating conditions" table • Updated "Voltage reference electrical specifications" section • Added "64-pin MAPBGA part marking" table
2	3/2014	Initial public release

Legal information

Data sheet status

Document status ^{[1][2]}	Product status ^[3]	Definition
Objective [short] data sheet	Development	This document contains data from the objective specification for product development.
Preliminary [short] data sheet	Qualification	This document contains data from the preliminary specification.
Product [short] data sheet	Production	This document contains the product specification.

[1] Please consult the most recently issued document before initiating or completing a design.

[2] The term 'short data sheet' is explained in section "Definitions".

[3] The product status of device(s) described in this document may have changed since this document was published and may differ in case of multiple devices. The latest product status information is available on the Internet at URL <http://www.nxp.com>.

Definitions

Draft — A draft status on a document indicates that the content is still under internal review and subject to formal approval, which may result in modifications or additions. NXP Semiconductors does not give any representations or warranties as to the accuracy or completeness of information included in a draft version of a document and shall have no liability for the consequences of use of such information.

Short data sheet — A short data sheet is an extract from a full data sheet with the same product type number(s) and title. A short data sheet is intended for quick reference only and should not be relied upon to contain detailed and full information. For detailed and full information see the relevant full data sheet, which is available on request via the local NXP Semiconductors sales office. In case of any inconsistency or conflict with the short data sheet, the full data sheet shall prevail.

Product specification — The information and data provided in a Product data sheet shall define the specification of the product as agreed between NXP Semiconductors and its customer, unless NXP Semiconductors and customer have explicitly agreed otherwise in writing. In no event however, shall an agreement be valid in which the NXP Semiconductors product is deemed to offer functions and qualities beyond those described in the Product data sheet.

Disclaimers

Limited warranty and liability — Information in this document is believed to be accurate and reliable. However, NXP Semiconductors does not give any representations or warranties, expressed or implied, as to the accuracy or completeness of such information and shall have no liability for the consequences of use of such information. NXP Semiconductors takes no responsibility for the content in this document if provided by an information source outside of NXP Semiconductors.

In no event shall NXP Semiconductors be liable for any indirect, incidental, punitive, special or consequential damages (including - without limitation - lost profits, lost savings, business interruption, costs related to the removal or replacement of any products or rework charges) whether or not such damages are based on tort (including negligence), warranty, breach of contract or any other legal theory.

Notwithstanding any damages that customer might incur for any reason whatsoever, NXP Semiconductors' aggregate and cumulative liability towards customer for the products described herein shall be limited in accordance with the Terms and conditions of commercial sale of NXP Semiconductors.

Right to make changes — NXP Semiconductors reserves the right to make changes to information published in this document, including without limitation specifications and product descriptions, at any time and without notice. This document supersedes and replaces all information supplied prior to the publication hereof.

Suitability for use — NXP Semiconductors products are not designed, authorized or warranted to be suitable for use in life support, life-critical or safety-critical systems or equipment, nor in applications where failure or malfunction of an NXP Semiconductors product can reasonably be expected to result in personal injury, death or severe property or environmental damage. NXP Semiconductors and its suppliers accept no liability for inclusion and/or use of NXP Semiconductors products in such equipment or applications and therefore such inclusion and/or use is at the customer's own risk.

Applications — Applications that are described herein for any of these products are for illustrative purposes only. NXP Semiconductors makes no representation or warranty that such applications will be suitable for the specified use without further testing or modification.

Customers are responsible for the design and operation of their applications and products using NXP Semiconductors products, and NXP Semiconductors accepts no liability for any assistance with applications or customer product design. It is customer's sole responsibility to determine whether the NXP Semiconductors product is suitable and fit for the customer's applications and products planned, as well as for the planned application and use of customer's third party customer(s). Customers should provide appropriate design and operating safeguards to minimize the risks associated with their applications and products.

NXP Semiconductors does not accept any liability related to any default, damage, costs or problem which is based on any weakness or default in the customer's applications or products, or the application or use by customer's third party customer(s). Customer is responsible for doing all necessary testing for the customer's applications and products using NXP Semiconductors products in order to avoid a default of the applications and the products or of the application or use by customer's third party customer(s). NXP does not accept any liability in this respect.

Limiting values — Stress above one or more limiting values (as defined in the Absolute Maximum Ratings System of IEC 60134) will cause permanent damage to the device. Limiting values are stress ratings only and (proper) operation of the device at these or any other conditions above those given in the Recommended operating conditions section (if present) or the Characteristics sections of this document is not warranted. Constant or repeated exposure to limiting values will permanently and irreversibly affect the quality and reliability of the device.

Terms and conditions of commercial sale — NXP Semiconductors products are sold subject to the general terms and conditions of commercial sale, as published at <http://www.nxp.com/profile/terms>, unless otherwise agreed in a valid written individual agreement. In case an individual agreement is concluded only the terms and conditions of the respective agreement shall apply. NXP Semiconductors hereby expressly objects to applying the customer's general terms and conditions with regard to the purchase of NXP Semiconductors products by customer.

No offer to sell or license — Nothing in this document may be interpreted or construed as an offer to sell products that is open for acceptance or the grant, conveyance or implication of any license under any copyrights, patents or other industrial or intellectual property rights.

Quick reference data — The Quick reference data is an extract of the product data given in the Limiting values and Characteristics sections of this document, and as such is not complete, exhaustive or legally binding.

Export control — This document as well as the item(s) described herein may be subject to export control regulations. Export might require a prior authorization from competent authorities.

Suitability for use in non-automotive qualified products — Unless this data sheet expressly states that this specific NXP Semiconductors product is automotive qualified, the product is not suitable for automotive use. It is neither qualified nor tested in accordance with automotive testing or application requirements. NXP Semiconductors accepts no liability for inclusion and/or use of non-automotive qualified products in automotive equipment or applications.

In the event that customer uses the product for design-in and use in automotive applications to automotive specifications and standards, customer (a) shall use the product without NXP Semiconductors' warranty of the product for such automotive applications, use and specifications, and (b) whenever customer uses the product for automotive applications beyond NXP Semiconductors' specifications such use shall be solely at customer's own risk, and (c) customer fully indemnifies NXP Semiconductors for any liability, damages or failed product claims resulting from customer design and use of the product for automotive applications beyond NXP Semiconductors' standard warranty and NXP Semiconductors' product specifications.

Translations — A non-English (translated) version of a document, including the legal information in that document, is for reference only. The English version shall prevail in case of any discrepancy between the translated and English versions.

Security — Customer understands that all NXP products may be subject to unidentified vulnerabilities or may support established security standards or specifications with known limitations. Customer is responsible for the design and operation of its applications and products throughout their lifecycles to reduce the effect of these vulnerabilities on customer's applications and products. Customer's responsibility also extends to other open and/or proprietary technologies supported by NXP products for use in customer's applications. NXP accepts no liability for any vulnerability. Customer should regularly check security updates from NXP and follow up appropriately.

Customer shall select products with security features that best meet rules, regulations, and standards of the intended application and make the ultimate design decisions regarding its products and is solely responsible for compliance with all legal, regulatory, and security related requirements concerning its products, regardless of any information or support that may be provided by NXP.

NXP has a Product Security Incident Response Team (PSIRT) (reachable at PSIRT@nxp.com) that manages the investigation, reporting, and solution release to security vulnerabilities of NXP products.

NXP B.V. - NXP B.V. is not an operating company and it does not distribute or sell products.

Trademarks

Notice: All referenced brands, product names, service names, and trademarks are the property of their respective owners.

NXP — wordmark and logo are trademarks of NXP B.V.

AMBA, Arm, Arm7, Arm7TDMI, Arm9, Arm11, Artisan, big.LITTLE, Cordio, CoreLink, CoreSight, Cortex, DesignStart, DynamiQ, Jazelle, Keil, Mali, Mbed, Mbed Enabled, NEON, POP, RealView, SecurCore, Socrates, Thumb, TrustZone, ULINK, ULINK2, ULINK-ME, ULINK-PLUS, ULINKpro, μ Vision, Versatile — are trademarks and/or registered trademarks of Arm Limited (or its subsidiaries or affiliates) in the US and/or elsewhere. The related technology may be protected by any or all of patents, copyrights, designs and trade secrets. All rights reserved.

I2C-bus — logo is a trademark of NXP B.V.

Kinetis — is a trademark of NXP B.V.

NXP SECURE CONNECTIONS FOR A SMARTER WORLD — is a trademark of NXP B.V.

arm

Please be aware that important notices concerning this document and the product(s) described herein, have been included in section 'Legal information'.

© NXP B.V. 2023.

All rights reserved.

For more information, please visit: <http://www.nxp.com>

For sales office addresses, please send an email to: salesaddresses@nxp.com

Date of release: 06/2023

Document identifier: K22P121M120SF7

Looking for pricing, stock, or lifecycle information?

Click below to explore more details on WIN SOURCE:

 [View MK22FN512VLL12R on WIN SOURCE](#)

 [NXP / Nexperia Information](#)

Optimize Your Supply Chain with WIN SOURCE Solutions

-  Global Sourcing Solution
-  Obsolete Management
-  Cost Control Management
-  Shortage Management
-  Alternative Solution
-  Excess Inventory Management