



**THE DATASHEET OF  
AD5761ARUZ**



## FEATURES

- 8 software-programmable output ranges: 0 V to +5 V, 0 V to +10 V, 0 V to +16 V, 0 V to +20 V,  $\pm 3$  V,  $\pm 5$  V,  $\pm 10$  V,  $-2.5$  V to  $+7.5$  V; 5% overrange**
- Total unadjusted error (TUE): 0.1% FSR maximum**
- 16-bit resolution:  $\pm 2$  LSB maximum INL**
- Guaranteed monotonicity:  $\pm 1$  LSB maximum**
- Single channel, 16-/12-bit DACs**
- Settling time: 7.5  $\mu$ s typical**
- Integrated reference buffers**
- Low noise: 35 nV/ $\sqrt{\text{Hz}}$**
- Low glitch: 1 nV-sec**
- 1.8 V logic compatibility**
- Asynchronous updating via  $\overline{\text{LDAC}}$**
- Asynchronous  $\overline{\text{RESET}}$  to zero scale/midscale**
- DSP/microcontroller-compatible serial interface**
- Robust 4 kV HBM ESD rating**
- Available in 16-lead TSSOP and 16-lead LFCSP**
- Operating temperature range:  $-40^{\circ}\text{C}$  to  $+125^{\circ}\text{C}$**

## APPLICATIONS

- Industrial automation
- Instrumentation, data acquisition
- Open-/closed-loop servo control, process control
- Programmable logic controllers

## GENERAL DESCRIPTION

The AD5761/AD5721 are single channel, 16-/12-bit serial input, voltage output, digital-to-analog converters (DACs). They operate from single supply voltages from +4.75 V to +30 V or dual supply voltages from  $-16.5$  V to 0 V  $V_{SS}$  and +4.75 V to +16.5 V  $V_{DD}$ . The integrated output amplifier and reference buffer provide a very easy to use, universal solution.

The devices offer guaranteed monotonicity, integral nonlinearity (INL) of  $\pm 2$  LSB maximum, 35 nV/ $\sqrt{\text{Hz}}$  noise, and 7.5  $\mu$ s settling time on selected ranges.

The AD5761/AD5721 use a serial interface that operates at clock rates of up to 50 MHz and are compatible with DSP and microcontroller interface standards. Double buffering allows the asynchronous updating of the DAC output. The input coding is user-selectable twos complement or straight binary. The asynchronous reset function resets all registers to their default state. The output range is user selectable, via the RA[2:0] bits in the control register.

The devices available in the 16-lead TSSOP and in the 16-lead LFCSP offer guaranteed specifications over the  $-40^{\circ}\text{C}$  to  $+125^{\circ}\text{C}$  industrial temperature range.

Table 1. Pin-Compatible Devices

Device	Description
AD5761R/AD5721R	AD5761/AD5721 with internal reference

## FUNCTIONAL BLOCK DIAGRAM

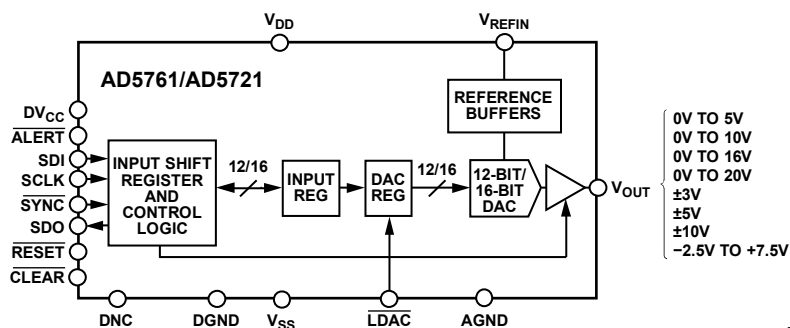

NOTES  
1. DNC = DO NOT CONNECT. DO NOT CONNECT TO THIS PIN.

Figure 1.

## TABLE OF CONTENTS

Features .....	1	Register Details .....	24
Applications .....	1	Input Shift Register .....	24
General Description .....	1	Control Register .....	24
Functional Block Diagram .....	1	Readback Control Register .....	26
Revision History .....	2	Update DAC Register from Input Register .....	26
Specifications .....	3	Readback DAC Register .....	26
AC Performance Characteristics .....	5	Write and Update DAC Register .....	27
Timing Characteristics .....	6	Readback Input Register .....	27
Absolute Maximum Ratings .....	8	Disable Daisy-Chain Functionality .....	27
ESD Caution .....	8	Software Data Reset .....	28
Pin Configurations and Function Descriptions .....	9	Software Full Reset .....	28
Typical Performance Characteristics .....	10	No Operation Registers .....	28
Terminology .....	20	Applications Information .....	29
Theory of Operation .....	21	Typical Operating Circuit .....	29
Digital-to-Analog Converter .....	21	Power Supply Considerations .....	29
Transfer Function .....	21	Evaluation Board .....	29
DAC Architecture .....	21	Outline Dimensions .....	31
Serial Interface .....	22	Ordering Guide .....	31
Hardware Control Pins .....	22		

## REVISION HISTORY

### 1/2018—Rev. B to Rev. C

Changes to Transfer Function Section .....	21
Change to DB[15:11] Column, Table 11 .....	24
Change to RA[2:0] Description, Table 12 .....	25
Change to DB[15:13] Column, Table 15 .....	26
Updated Outline Dimensions .....	31
Changes to Ordering Guide .....	31

### 4/2016—Rev. A to Rev. B

Changes to Features Section .....	1
Changes to Typical Operating Circuit Section and Precision Voltage Reference Section .....	29

### 5/2015—Rev. 0 to Rev. A

Added 16-Lead LFCSP Package .....	Universal
Added Grade A Parameter, Table 2 .....	3
Added Figure 5, Renumbered Sequentially .....	9
Changes to Table 6 .....	9
Changes to Figure 49 .....	17
Changes to Power Supply Considerations Section .....	30
Updated Outline Dimensions .....	32
Changes to Ordering Guide .....	32

### 1/2015—Revision 0: Initial Version

## SPECIFICATIONS

$V_{DD}^1 = 4.75 \text{ V to } 30 \text{ V}$ ,  $V_{SS}^1 = -16.5 \text{ V to } 0 \text{ V}$ ,  $AGND = DGND = 0 \text{ V}$ ,  $V_{REFIN} = 2.5 \text{ V external}$ ,  $DV_{CC} = 1.7 \text{ V to } 5.5 \text{ V}$ ,  $R_{LOAD} = 1 \text{ k}\Omega$  for all ranges except  $0 \text{ V to } 16 \text{ V}$  and  $0 \text{ V to } 20 \text{ V}$  for which  $R_{LOAD} = 2 \text{ k}\Omega$ ,  $C_{LOAD} = 200 \text{ pF}$ , all specifications  $T_{MIN}$  to  $T_{MAX}$ , unless otherwise noted.

Table 2.

Parameter <sup>2</sup>	Min	Typ	Max	Unit	Test Conditions/Comments
STATIC PERFORMANCE					
Programmable Output Ranges	0		5	V	External reference <sup>3</sup> , outputs unloaded
	0		10	V	
	0		16	V	
	0		20	V	
	-2.5		+7.5	V	
	-3		+3	V	
	-5		+5	V	
	-10		+10	V	
<b>AD5761</b>					
Resolution	16			Bits	External reference <sup>3</sup> All ranges except $0 \text{ V to } 16 \text{ V}$ and $0 \text{ V to } 20 \text{ V}$ , $V_{REFIN} = 2.5 \text{ V external reference}$
Relative Accuracy, INL					
A Grade	-8		+8	LSB	
B Grade <sup>4</sup>	-2		+2	LSB	
Differential Nonlinearity, DNL	-1		+1	LSB	
<b>AD5721</b>					
Resolution	12			Bits	External reference <sup>3</sup> All ranges except $\pm 10 \text{ V}$ and $0 \text{ V to } 20 \text{ V}$ , external reference <sup>3</sup>
Relative Accuracy, INL					
B Grade	-0.5		+0.5	LSB	
Differential Nonlinearity, DNL	-0.5		+0.5	LSB	
Zero-Scale Error	-6		+6	mV	All ranges except $\pm 10 \text{ V}$ and $0 \text{ V to } 20 \text{ V}$ , external reference <sup>3</sup> $0 \text{ V to } 20 \text{ V}$ , $\pm 10 \text{ V}$ ranges, external reference <sup>3</sup>
	-10		+10	mV	
Zero-Scale Temperature Coefficient (TC) <sup>5</sup>		$\pm 5$		$\mu\text{V}/^\circ\text{C}$	Unipolar ranges, external reference <sup>3</sup> Bipolar ranges, external reference <sup>3</sup>
		$\pm 15$		$\mu\text{V}/^\circ\text{C}$	
Bipolar Zero Error	-5		+5	mV	All bipolar ranges except $\pm 10 \text{ V}$ $\pm 10 \text{ V}$ output range
	-7		+7	mV	
Bipolar Zero TC <sup>5</sup>		$\pm 2$		$\mu\text{V}/^\circ\text{C}$	$\pm 3 \text{ V}$ range, external reference <sup>3</sup> All bipolar ranges except $\pm 3 \text{ V}$ , external reference <sup>3</sup>
		$\pm 5$		$\mu\text{V}/^\circ\text{C}$	
Offset Error	-6		+6	mV	All ranges except $\pm 10 \text{ V}$ and $0 \text{ V to } 20 \text{ V}$ , external reference <sup>3</sup> $0 \text{ V to } 20 \text{ V}$ , $\pm 10 \text{ V}$ ranges; external reference <sup>3</sup>
	-10		+10	mV	
Offset Error TC <sup>5</sup>		$\pm 5$		$\mu\text{V}/^\circ\text{C}$	Unipolar ranges, external reference <sup>3</sup> Bipolar ranges, external reference <sup>3</sup>
		$\pm 15$		$\mu\text{V}/^\circ\text{C}$	
Gain Error	-0.1		+0.1	% FSR	External reference <sup>3</sup> External reference <sup>3</sup>
Gain Error TC <sup>5</sup>		$\pm 1.5$		ppm FSR/ $^\circ\text{C}$	
Total Unadjusted Error (TUE)	-0.1		+0.1	% FSR	External reference <sup>3</sup>
REFERENCE INPUT <sup>5</sup>					
Reference Input Voltage ( $V_{REF}$ )		2.5		V	$\pm 1\%$ for specified performance
Input Current	-2	$\pm 0.5$	+2	$\mu\text{A}$	
Reference Range	2		3	V	
OUTPUT CHARACTERISTICS <sup>5</sup>					
Output Voltage Range	$-V_{OUT}$		$+V_{OUT}$		Refer to Table 7 for the different output voltage ranges available $V_{DD}/V_{SS} = \pm 11 \text{ V}$ , $\pm 10 \text{ V}$ output range $V_{DD}/V_{SS} = \pm 11 \text{ V}$ , $\pm 10 \text{ V}$ output range with 5% overrange
	-10		+10	V	
	-10.5		+10.5	V	

Parameter <sup>2</sup>	Min	Typ	Max	Unit	Test Conditions/Comments
Capacitive Load Stability			1	nF	
Headroom		0.5	1	V	$R_{LOAD} = 1\text{ k}\Omega$ for all ranges except 0 V to 16 V and 0 V to 20 V ranges ( $R_{LOAD} = 2\text{ k}\Omega$ )
Output Voltage TC		$\pm 3$		ppm FSR/ $^{\circ}\text{C}$	$\pm 10\text{ V}$ range, external reference
Short-Circuit Current		25		mA	Short on the $V_{OUT}$ pin
Resistive Load			1	$\text{k}\Omega$	All ranges except 0 V to 16 V and 0 V to 20 V
			2	$\text{k}\Omega$	0 V to 16 V, 0 V to 20 V ranges
Load Regulation		0.3		mV/mA	Outputs unloaded
DC Output Impedance		0.5		$\Omega$	Outputs unloaded
LOGIC INPUTS <sup>5</sup>					$DV_{CC} = 1.7\text{ V to }5.5\text{ V}$ , JEDEC compliant
Input Voltage					
High, $V_{IH}$	$0.7 \times DV_{CC}$			V	
Low, $V_{IL}$			$0.3 \times DV_{CC}$	V	
Input Current					
Leakage Current	-1		+1	$\mu\text{A}$	$\overline{\text{SDI}}$ , $\overline{\text{SCLK}}$ , $\overline{\text{SYNC}}$
	-1		+1	$\mu\text{A}$	$\overline{\text{LDAC}}$ , $\overline{\text{CLEAR}}$ , $\overline{\text{RESET}}$ pins held high
	-55			$\mu\text{A}$	$\overline{\text{LDAC}}$ , $\overline{\text{CLEAR}}$ , $\overline{\text{RESET}}$ pins held low
Pin Capacitance		5		pF	Per pin, outputs unloaded
LOGIC OUTPUTS (SDO, ALERT) <sup>5</sup>					
Output Voltage					
Low, $V_{OL}$			0.4	V	$DV_{CC} = 1.7\text{ V to }5.5\text{ V}$ , sinking 200 $\mu\text{A}$
High, $V_{OH}$	$DV_{CC} - 0.5$			V	$DV_{CC} = 1.7\text{ V to }5.5\text{ V}$ , sourcing 200 $\mu\text{A}$
High Impedance, SDO Pin					
Leakage Current	-1		+1	$\mu\text{A}$	
Pin Capacitance		5		pF	
POWER REQUIREMENTS					
$V_{DD}$	4.75		30	V	
$V_{SS}$	-16.5		0	V	
$DV_{CC}$	1.7		5.5	V	
$I_{DD}$		5.1	6.5	mA	Outputs unloaded, external reference
$I_{SS}$		1	3	mA	Outputs unloaded
$D I_{CC}$		0.005	1	$\mu\text{A}$	$V_{IH} = DV_{CC}$ , $V_{IL} = \text{DGND}$
Power Dissipation		67.1		mW	$\pm 11\text{ V}$ operation, outputs unloaded
DC Power Supply Rejection Ratio (PSRR) <sup>5</sup>		0.1		mV/V	$V_{DD} \pm 10\%$ , $V_{SS} = -15\text{ V}$
		0.1		mV/V	$V_{SS} \pm 10\%$ , $V_{DD} = +15\text{ V}$
AC PSRR <sup>5</sup>		80		dB	$V_{DD} \pm 200\text{ mV}$ , 50 Hz/60 Hz, $V_{SS} = -15\text{ V}$ ; external reference; $C_{LOAD} = \text{unloaded}$
		80		dB	$V_{SS} \pm 200\text{ mV}$ , 50 Hz/60 Hz, $V_{DD} = +15\text{ V}$ ; external reference; $C_{LOAD} = \text{unloaded}$

<sup>1</sup> For specified performance, headroom requirement is 1 V.

<sup>2</sup> Temperature range:  $-40^{\circ}\text{C}$  to  $+125^{\circ}\text{C}$ , typical at  $+25^{\circ}\text{C}$ .

<sup>3</sup> External reference means 2 V to 2.85 V with overrange and 2 V to 3 V without overrange.

<sup>4</sup> Integral nonlinearity error is specified at  $\pm 4\text{ LSB}$  (minimum/maximum) for 0 V to 16 V and 0 V to 20 V ranges with  $V_{REFIN} = 2.5\text{ V}$  external reference, and for all ranges with  $V_{REFIN} = 2\text{ V to }2.85\text{ V}$  with overrange and 2 V to 3 V without overrange.

<sup>5</sup> Guaranteed by design and characterization, not production tested.

**AC PERFORMANCE CHARACTERISTICS**

$V_{DD}^1 = 4.75 \text{ V to } 30 \text{ V}$ ,  $V_{SS}^1 = -16.5 \text{ V to } 0 \text{ V}$ ,  $AGND = DGND = 0 \text{ V}$ ,  $V_{REFIN} = 2.5 \text{ V external}$ ,  $DV_{CC} = 1.7 \text{ V to } 5.5 \text{ V}$ ,  $R_{LOAD} = 1 \text{ k}\Omega$  for all ranges except  $0 \text{ V to } 16 \text{ V}$  and  $0 \text{ V to } 20 \text{ V}$  for which  $R_{LOAD} = 2 \text{ k}\Omega$ ,  $C_{LOAD} = 200 \text{ pF}$ , all specifications  $T_{MIN}$  to  $T_{MAX}$ , unless otherwise noted.

**Table 3.**

Parameter <sup>2</sup>	Min	Typ	Max	Unit	Test Conditions/Comments
<b>DYNAMIC PERFORMANCE<sup>3</sup></b>					
Output Voltage Settling Time		9	12.5	$\mu\text{s}$	20 V step to 1 LSB at 16-bit resolution
		7.5	8.5	$\mu\text{s}$	10 V step to 1 LSB at 16-bit resolution
			5	$\mu\text{s}$	512 LSB step to 1 LSB at 16-bit resolution
Digital-to-Analog Glitch Impulse		8		nV-sec	$\pm 10 \text{ V range}$
		1		nV-sec	0 V to 5 V range
Glitch Impulse Peak Amplitude		15		mV	$\pm 10 \text{ V range}$
		10		mV	0 V to 5 V range
Power-On Glitch		100		mV p-p	
Digital Feedthrough		0.6		nV-sec	
Output Noise					
0.1 Hz to 10 Hz Bandwidth (BW)		15		$\mu\text{V p-p}$	
100 kHz BW		45		$\mu\text{V rms}$	0 V to 20 V and 0 V to 16 V ranges, 2.5 V external reference
		35		$\mu\text{V rms}$	0 V to 10 V, $\pm 10 \text{ V}$ , $-2.5 \text{ V to } +7.5 \text{ V}$ ranges, 2.5 V external reference
		25		$\mu\text{V rms}$	$\pm 5 \text{ V range}$ , 2.5 V external reference
		15		$\mu\text{V rms}$	$+5 \text{ V}$ , $\pm 3 \text{ V}$ ranges; 2.5 V external reference
Output Noise Spectral Density (at 10 kHz)		80		$\text{nV}/\sqrt{\text{Hz}}$	$\pm 10 \text{ V range}$ , 2.5 V external reference
		35		$\text{nV}/\sqrt{\text{Hz}}$	$\pm 3 \text{ V range}$ , 2.5 V external reference
		70		$\text{nV}/\sqrt{\text{Hz}}$	$\pm 5 \text{ V}$ , 0 V to 10 V, and $-2.5 \text{ V to } +7.5 \text{ V}$ ranges; 2.5 V external reference
		110		$\text{nV}/\sqrt{\text{Hz}}$	0 V to 20 V range, 2.5 V external reference
		90		$\text{nV}/\sqrt{\text{Hz}}$	0 V to 16 V range, 2.5 V external reference
	45		$\text{nV}/\sqrt{\text{Hz}}$	0 V to 5 V range, 2.5 V external reference	
Total Harmonic Distortion (THD) <sup>4</sup>		-87		dB	2.5 V external reference, 1 kHz tone
Signal-to-Noise Ratio (SNR)		92		dB	At ambient, 2.5 V external reference, BW = 20 kHz, $f_{OUT} = 1 \text{ kHz}$
Peak Harmonic or Spurious Noise (SFDR)		92		dB	At ambient, 2.5 V external reference, BW = 20 kHz, $f_{OUT} = 1 \text{ kHz}$
Signal-to-Noise-and-Distortion (SINAD) Ratio		85		dB	At ambient, 2.5 V external reference, BW = 20 kHz, $f_{OUT} = 1 \text{ kHz}$

<sup>1</sup> For specified performance, headroom requirement is 1 V.

<sup>2</sup> Temperature range:  $-40^\circ\text{C}$  to  $+125^\circ\text{C}$ , typical at  $+25^\circ\text{C}$ .

<sup>3</sup> Guaranteed by design and characterization; not production tested.

<sup>4</sup> Digitally generated sine wave at 1 kHz.

**TIMING CHARACTERISTICS**

DV<sub>CC</sub> = 1.7 V to 5.5 V, all specifications T<sub>MIN</sub> to T<sub>MAX</sub>, unless otherwise noted.

Table 4.

Parameter	Limit at T <sub>MIN</sub> to T <sub>MAX</sub>	Unit	Description
t <sub>1</sub> <sup>1</sup>	20	ns min	SCLK cycle time
t <sub>2</sub>	10	ns min	SCLK high time
t <sub>3</sub>	10	ns min	SCLK low time
t <sub>4</sub>	15	ns min	$\overline{\text{SYNC}}$ falling edge to SCLK falling edge setup time
t <sub>5</sub>	10	ns min	SCLK falling edge to $\overline{\text{SYNC}}$ rising edge time
t <sub>6</sub>	20	ns min	Minimum $\overline{\text{SYNC}}$ high time (write mode)
t <sub>7</sub>	5	ns min	Data setup time
t <sub>8</sub>	5	ns min	Data hold time
t <sub>9</sub>	10	ns min	$\overline{\text{LDAC}}$ falling edge to $\overline{\text{SYNC}}$ falling edge
t <sub>10</sub>	20	ns min	$\overline{\text{SYNC}}$ rising edge to $\overline{\text{LDAC}}$ falling edge
t <sub>11</sub>	20	ns min	$\overline{\text{LDAC}}$ pulse width low
t <sub>12</sub>	9	$\mu\text{s typ}$	DAC output settling time, 20 V step to 1 LSB at 16-bit resolution (see Table 3)
	7.5	$\mu\text{s typ}$	DAC output settling time, 10 V step to 1 LSB at 16-bit resolution
t <sub>13</sub>	20	ns min	$\overline{\text{CLEAR}}$ pulse width low
t <sub>14</sub>	200	ns typ	$\overline{\text{CLEAR}}$ pulse activation time
t <sub>15</sub>	10	ns min	$\overline{\text{SYNC}}$ rising edge to SCLK falling edge
t <sub>16</sub>	40	ns max	SCLK rising edge to SDO valid (C <sub>L_SDO</sub> = 15 pF, where C <sub>L_SDO</sub> is the capacitive load on the SDO output)
t <sub>17</sub>	50	ns min	Minimum $\overline{\text{SYNC}}$ high time (readback/daisy-chain mode)

<sup>1</sup> Maximum SCLK frequency is 50 MHz for write mode and 33 MHz for readback mode.

**Timing Diagrams**

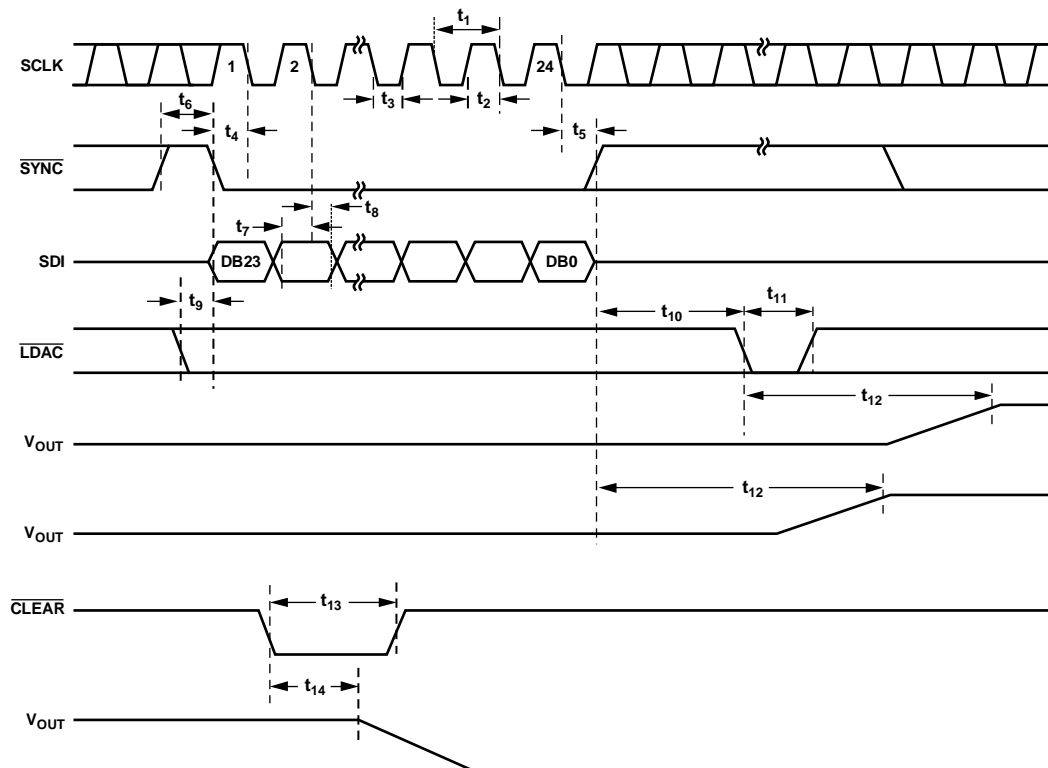

Figure 2. Serial Interface Timing Diagram

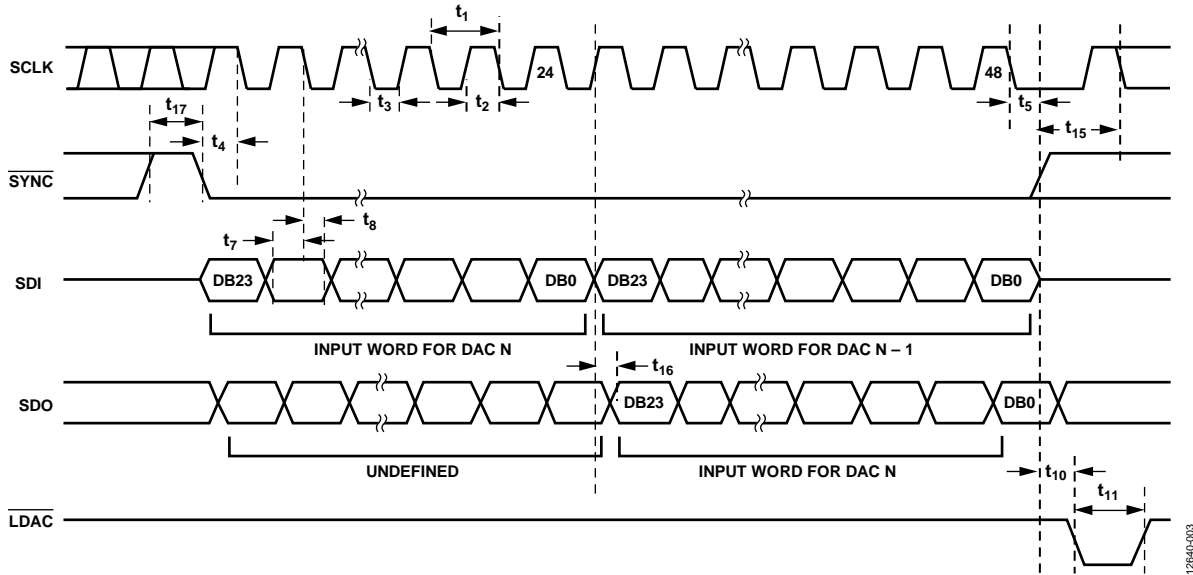

Figure 3. Daisy-Chain Timing Diagram

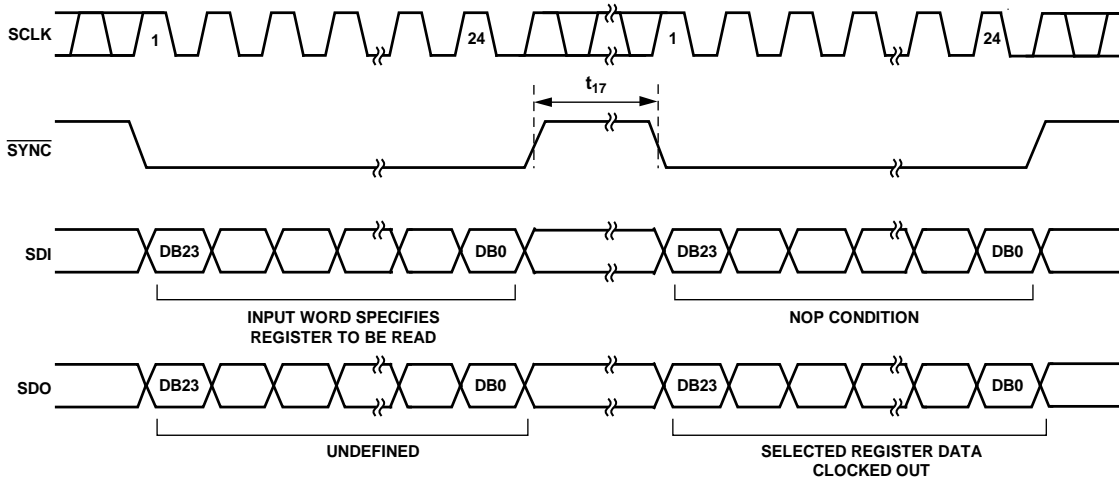

Figure 4. Readback Timing Diagram

12640-003

12640-004

## ABSOLUTE MAXIMUM RATINGS

$T_A = 25^\circ\text{C}$ , unless otherwise noted. Transient currents of up to 200 mA do not cause silicon controlled rectifier (SCR) latch-up.

Table 5.

Parameter	Rating
$V_{DD}$ to AGND	-0.3 V to +34 V
$V_{SS}$ to AGND	+0.3 V to -17 V
$V_{DD}$ to $V_{SS}$	-0.3 V to +34 V
$DV_{CC}$ to DGND	-0.3 V to +7 V
Digital Inputs <sup>1</sup> to DGND	-0.3 V to $DV_{CC} + 0.3$ V or 7 V (whichever is less)
Digital Outputs <sup>2</sup> to DGND	-0.3 V to $DV_{CC} + 0.3$ V or 7 V (whichever is less)
$V_{REFIN}$ to DGND	-0.3 V to +7 V
$V_{OUT}$ to AGND	$V_{SS}$ to $V_{DD}$
AGND to DGND	-0.3 V to +0.3 V
Operating Temperature Range, $T_A$ Industrial	-40°C to +125°C
Storage Temperature Range	-65°C to +150°C
Junction Temperature, $T_{J\text{MAX}}$	150°C
Thermal Impedance	
16-Lead TSSOP	
$\theta_{JA}$	113°C/W <sup>3</sup>
$\theta_{JC}$	28°C/W
16-Lead LFCSP	
$\theta_{JA}$	75°C/W <sup>3</sup>
$\theta_{JC}$	4.5°C/W <sup>4</sup>
Power Dissipation	$(T_{J\text{MAX}} - T_A)/\theta_{JA}$
Lead Temperature	JEDEC industry standard
Soldering	J-STD-020
ESD (Human Body Model)	4 kV

Stresses at or above those listed under Absolute Maximum Ratings may cause permanent damage to the product. This is a stress rating only; functional operation of the product at these or any other conditions above those indicated in the operational section of this specification is not implied. Operation beyond the maximum operating conditions for extended periods may affect product reliability.

### ESD CAUTION



**ESD (electrostatic discharge) sensitive device.** Charged devices and circuit boards can discharge without detection. Although this product features patented or proprietary protection circuitry, damage may occur on devices subjected to high energy ESD. Therefore, proper ESD precautions should be taken to avoid performance degradation or loss of functionality.

<sup>1</sup> The digital inputs include  $\overline{\text{CLEAR}}$ ,  $\overline{\text{RESET}}$ ,  $\overline{\text{SCLK}}$ ,  $\overline{\text{SYNC}}$ ,  $\overline{\text{SDI}}$ , and  $\overline{\text{LDAC}}$ .

<sup>2</sup> The digital outputs include  $\overline{\text{ALERT}}$  and  $\overline{\text{SDO}}$ .

<sup>3</sup> JEDEC 2S2P test board, still air (0 m/sec airflow).

<sup>4</sup> Measured to exposed paddle, with infinite heat sink on package top surface.

# PIN CONFIGURATIONS AND FUNCTION DESCRIPTIONS

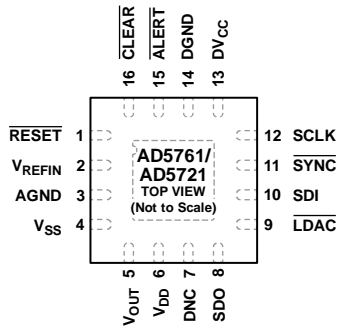

- NOTES**
1. DNC = DO NOT CONNECT. DO NOT CONNECT TO THIS PIN.
  2. EXPOSED PAD. ENSURE THAT THE EXPOSED PAD IS MECHANICALLY CONNECTED TO A PCB COPPER PLANE FOR OPTIMAL THERMAL PERFORMANCE. THE EXPOSED PAD CAN BE LEFT ELECTRICALLY FLOATING.

Figure 5. LFCSP Pin Configuration

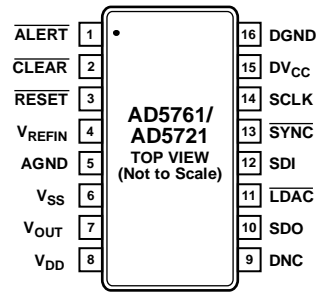

DNC = DO NOT CONNECT. DO NOT CONNECT TO THIS PIN.

12840-006

Figure 6. TSSOP Pin Configuration

Table 6. Pin Function Descriptions

Pin No.		Mnemonic	Description
LFCSP	TSSOP		
1	3	RESET	Active Low Reset Input. Asserting this pin returns the AD5761/AD5721 to their default power-on status where the output is clamped to ground and the output buffer is powered down. This pin can be left floating because there is an internal pull-up resistor.
2	4	VREFIN	External Reference Voltage Input. For specified performance, VREFIN = 2.5 V.
3	5	AGND	Ground Reference for Analog Circuitry.
4	6	VSS	Negative Analog Supply Connection. A voltage in the range of -16.5 V to 0 V can be connected to this pin. For unipolar output ranges, connect this pin to 0 V. VSS must be decoupled to AGND.
5	7	VOUT	Analog Output Voltage of the DAC. The output amplifier is capable of directly driving a 2 kΩ, 1 nF load.
6	8	VDD	Positive Analog Supply Connection. A voltage in the range of 4.75 V to 30 V can be connected to this pin for unipolar output ranges. Bipolar output ranges accept a voltage in the range of 4.75 V to 16.5 V. VDD must be decoupled to AGND.
7	9	DNC	Do Not Connect. Do not connect to this pin.
8	10	SDO	Serial Data Output. This pin clocks data from the serial register in daisy-chain or readback mode. Data is clocked out on the rising edge of SCLK and is valid on the falling edge of SCLK.
9	11	LDAC	Load DAC. This logic input updates the DAC register and, consequently, the analog output. When tied permanently low, the DAC register is updated when the input register is updated. If LDAC is held high during the write to the input register, the DAC output register is not updated, and the DAC output update is held off until the falling edge of LDAC. This pin can be left floating because there is an internal pull-up resistor.
10	12	SDI	Serial Data Input. Data must be valid on the falling edge of SCLK.
11	13	SYNC	Active Low Synchronization Input. This pin is the frame synchronization signal for the serial interface. While SYNC is low, data is transferred in on the falling edge of SCLK. Data is latched on the rising edge of SYNC.
12	14	SCLK	Serial Clock Input. Data is clocked into the input shift register on the falling edge of SCLK. This pin operates at clock speeds of up to 50 MHz.
13	15	DVCC	Digital Supply. The voltage range is from 1.7 V to 5.5 V. The applied voltage sets the voltage at which the digital interface operates.
14	16	DGND	Digital Ground.
15	1	ALERT	Active Low Alert. This pin is asserted low when the die temperature exceeds approximately 150°C, or when an output short circuit or a brownout occurs. This pin is also asserted low during power-up, a full software reset, or a hardware reset, for which a write to the control register asserts the pin high.
16	2	CLEAR	Falling Edge Clear Input. Asserting this pin sets the DAC register to zero-scale, midscale, or full-scale code (user selectable) and updates the DAC output. This pin can be left floating because there is an internal pull-up resistor.
17	N/A <sup>1</sup>	EPAD	Exposed Pad. Ensure that the exposed pad is mechanically connected to a PCB copper plane for optimal thermal performance. The exposed pad can be left electrically floating.

<sup>1</sup> N/A means not applicable.

TYPICAL PERFORMANCE CHARACTERISTICS

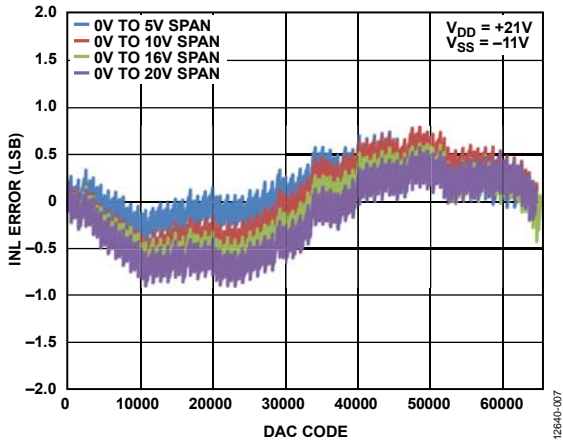

Figure 7. AD5761 INL Error vs. DAC Code, Unipolar Output

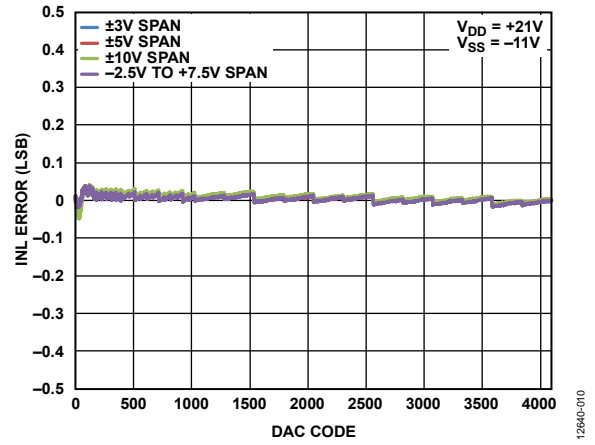

Figure 10. AD5721 INL Error vs. DAC Code, Bipolar Output

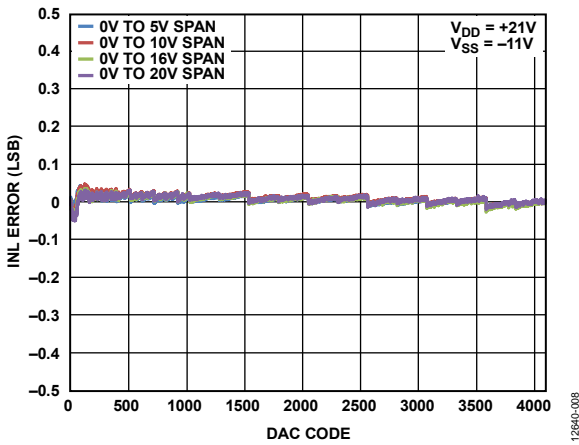

Figure 8. AD5721 INL Error vs. DAC Code, Unipolar Output

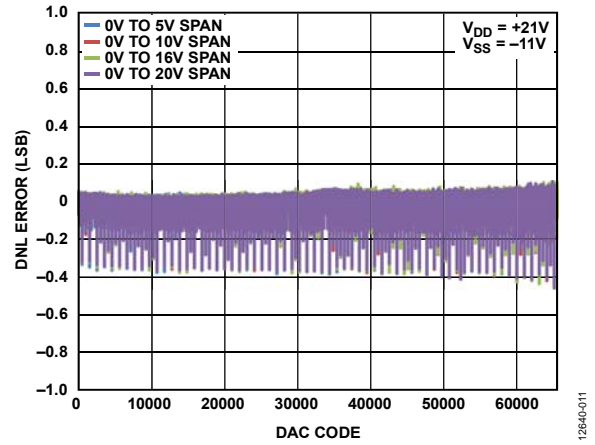

Figure 11. AD5761 DNL Error vs. DAC Code, Unipolar Output

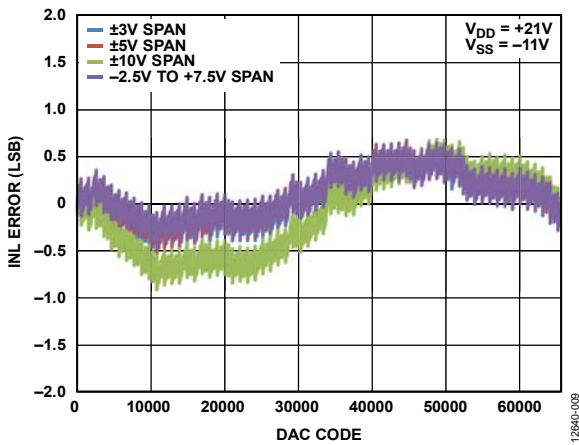

Figure 9. AD5761 INL Error vs. DAC Code, Bipolar Output

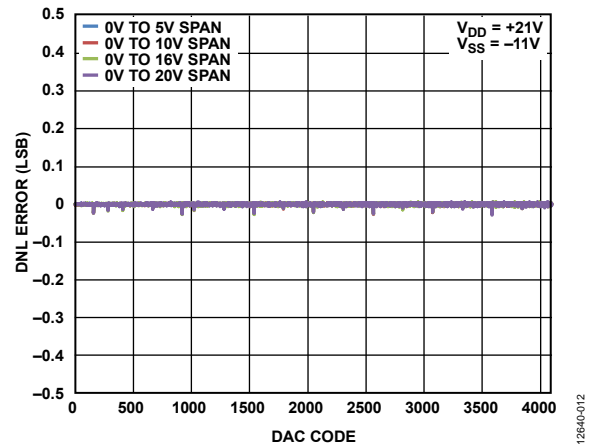

Figure 12. AD5721 DNL Error vs. DAC Code, Unipolar Output

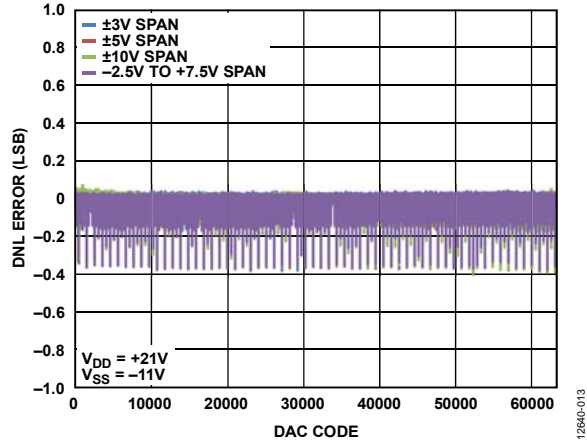

Figure 13. AD5761 DNL Error vs. DAC Code, Bipolar Output

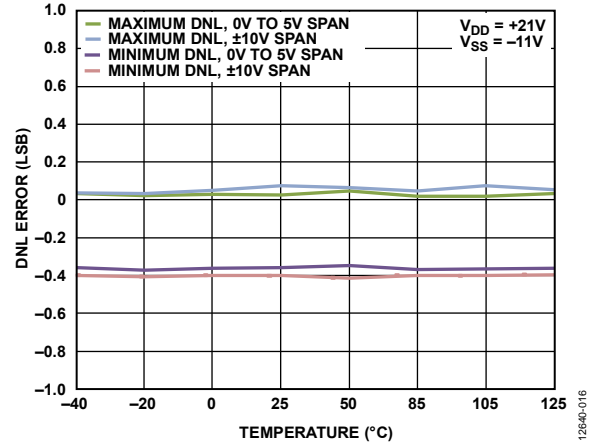

Figure 16. DNL Error vs. Temperature

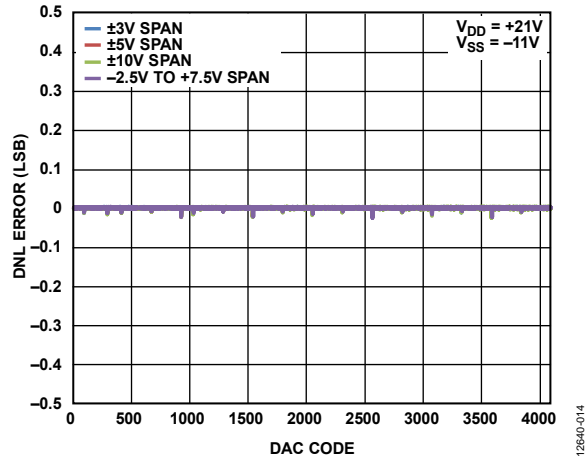

Figure 14. AD5721 DNL Error vs. DAC Code, Bipolar Output

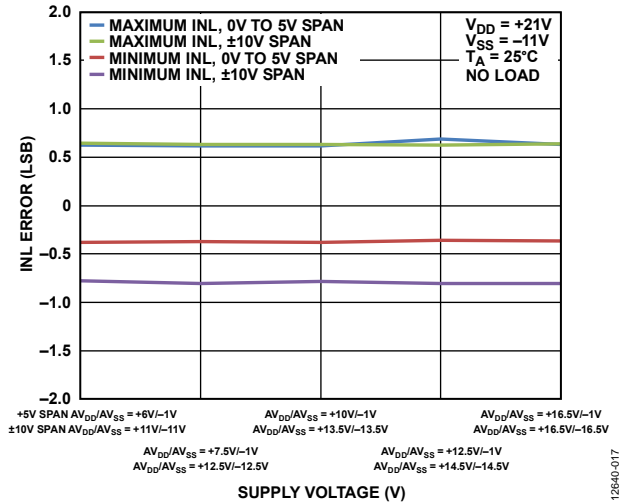

Figure 17. INL Error vs. Supply Voltage

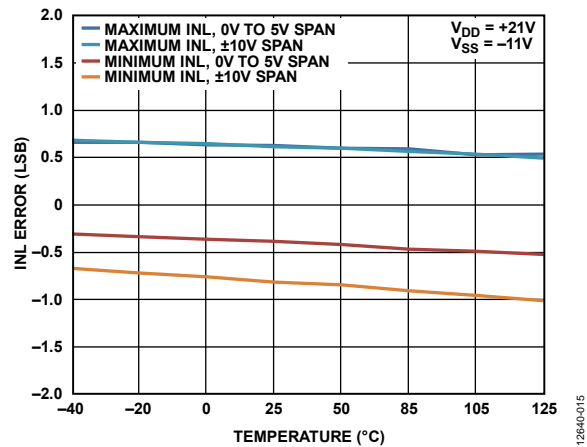

Figure 15. INL Error vs. Temperature

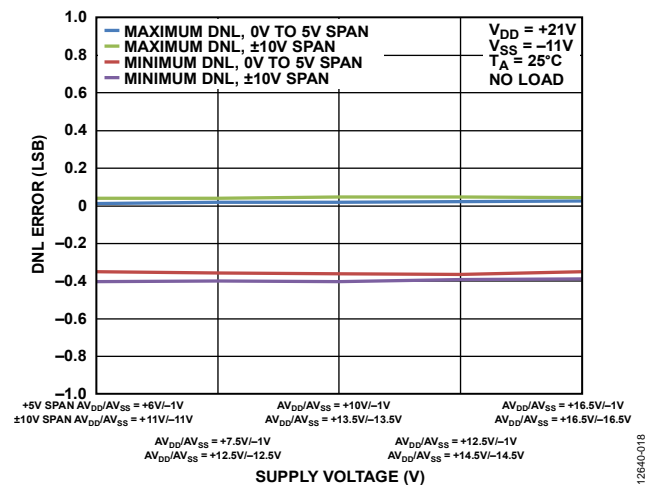

Figure 18. DNL Error vs. Supply Voltage

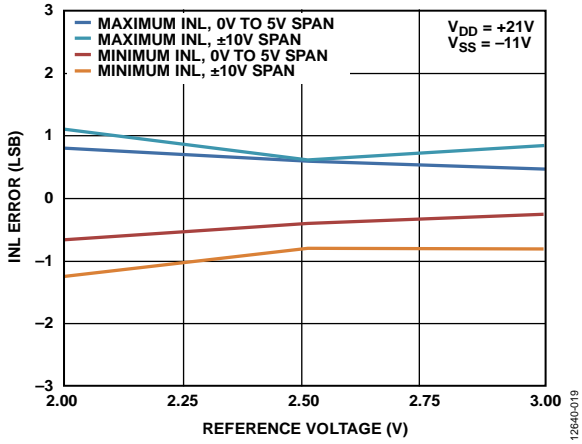

Figure 19. INL Error vs. Reference Voltage

12840-019

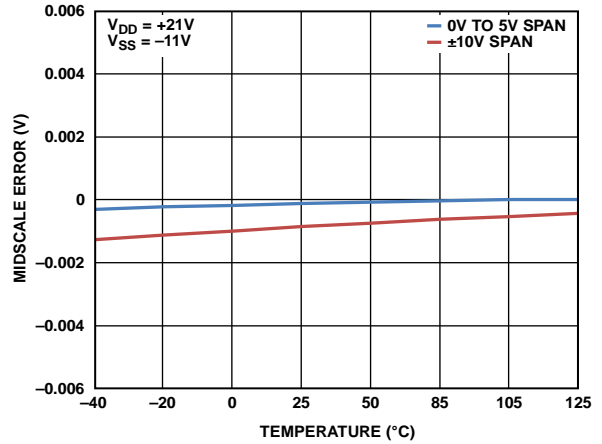

Figure 22. Midscale Error vs. Temperature

12840-022

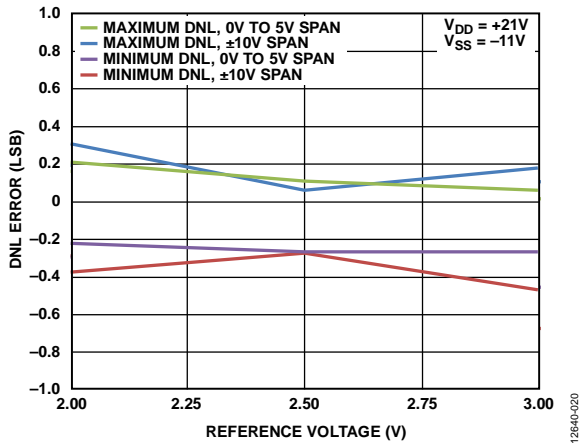

Figure 20. DNL Error vs. Reference Voltage

12840-020

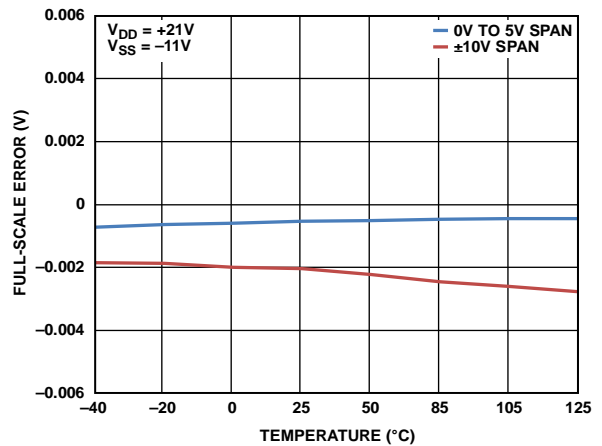

Figure 23. Full-Scale Error vs. Temperature

12840-023

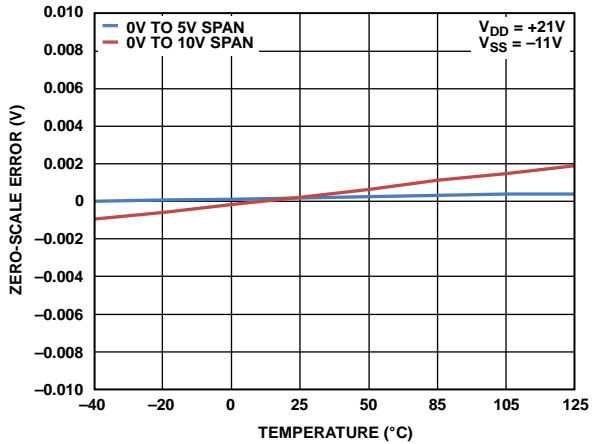

Figure 21. Zero-Scale Error vs. Temperature

12840-021

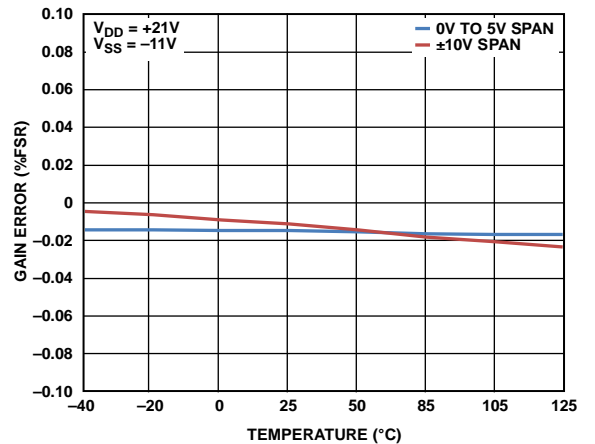
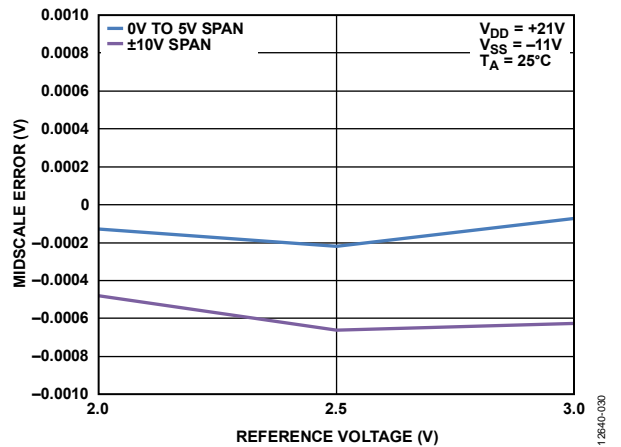
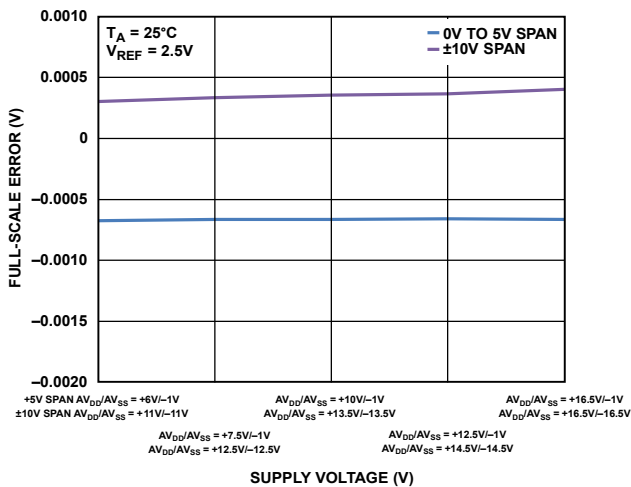
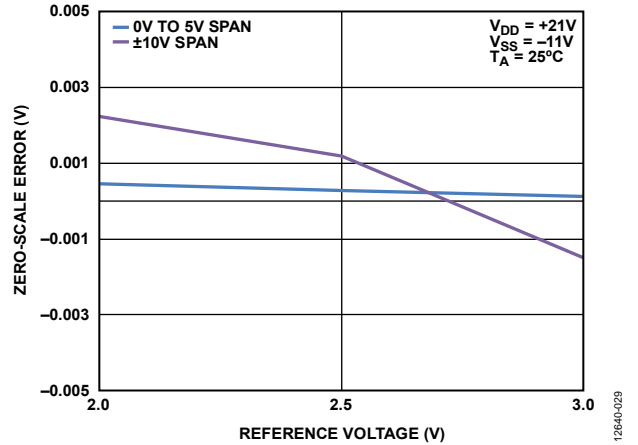
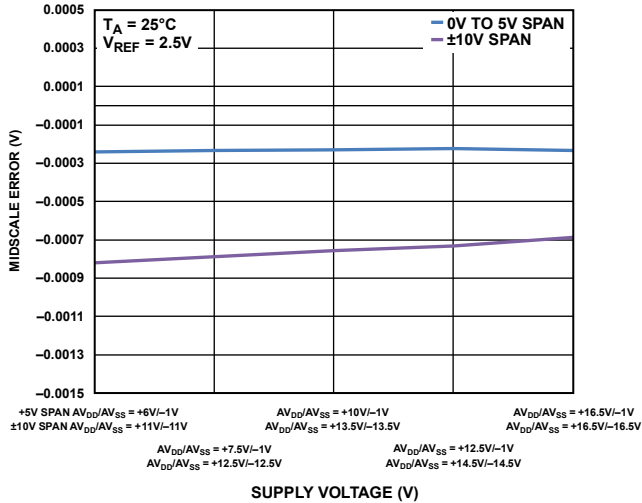
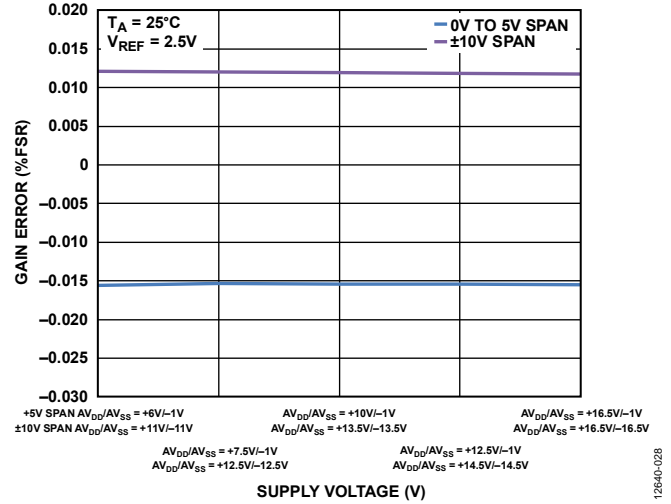
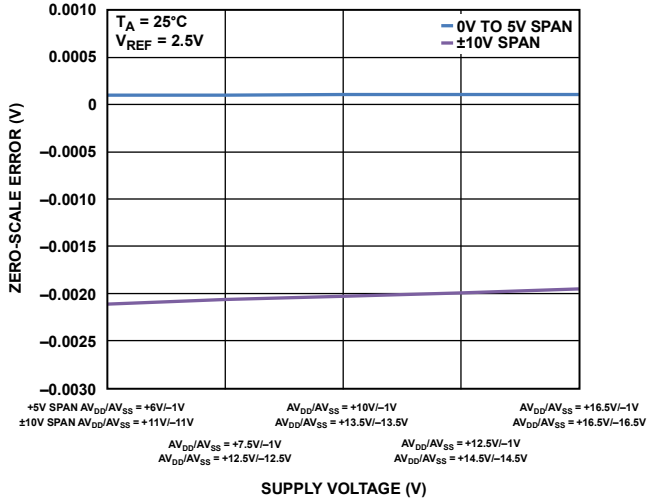

Figure 24. Gain Error vs. Temperature

12840-024



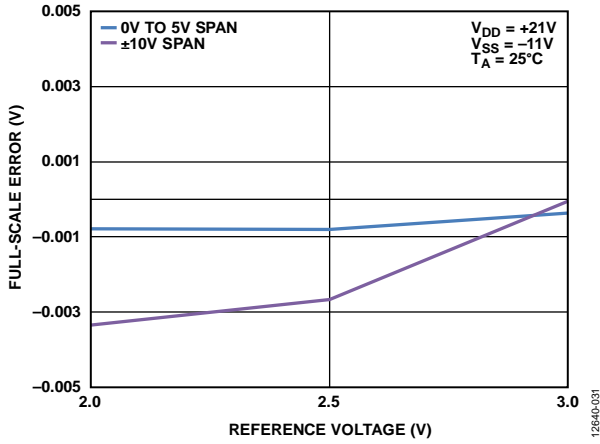

Figure 31. Full-Scale Error vs. Reference Voltage

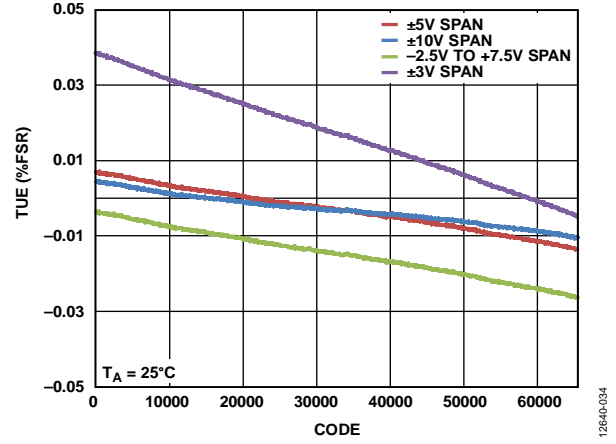

Figure 34. TUE vs. Code, Bipolar Output

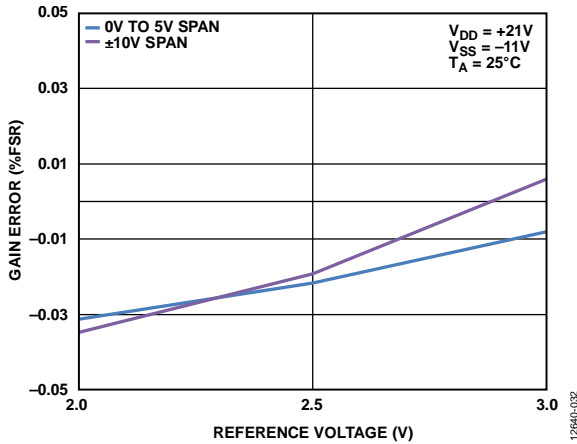

Figure 32. Gain Error vs. Reference Voltage

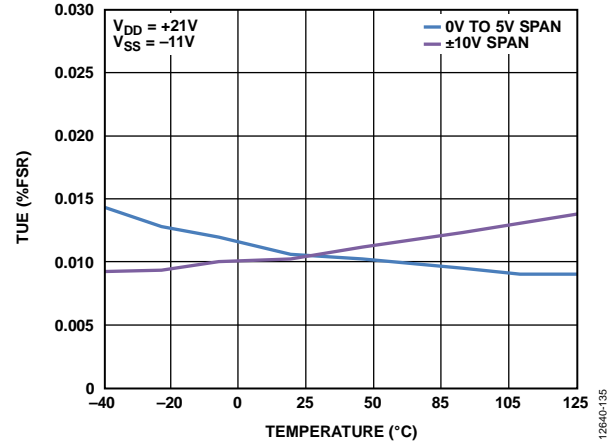

Figure 35. TUE vs. Temperature

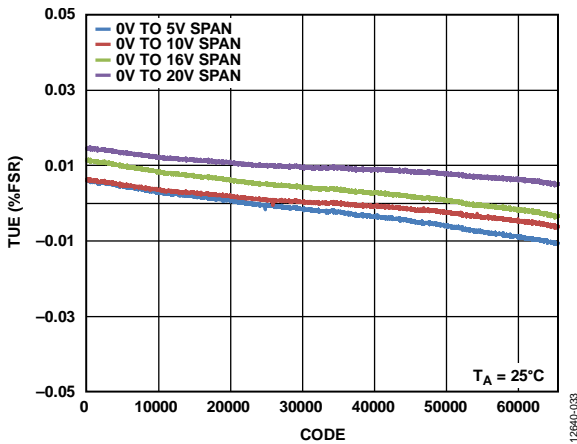

Figure 33. TUE vs. Code, Unipolar Output

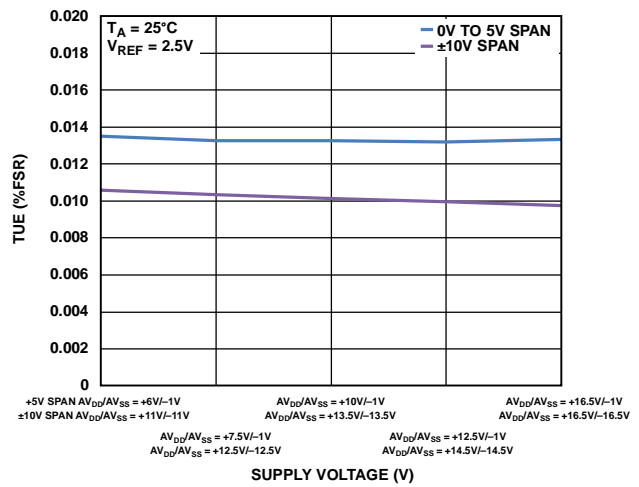

Figure 36. TUE vs. Supply Voltage

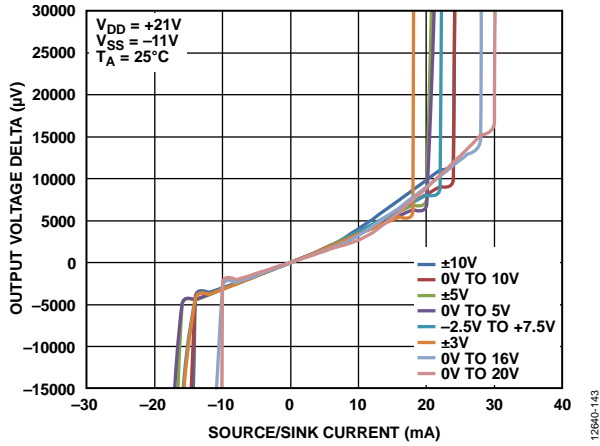

Figure 37. Source and Sink Capability of Output Amplifier with Positive Full Scale Loaded

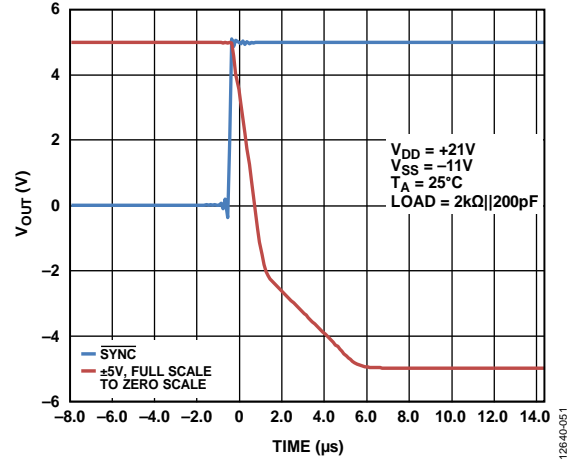

Figure 40. Full-Scale Settling Time (Falling Voltage Step), ±5 V Range

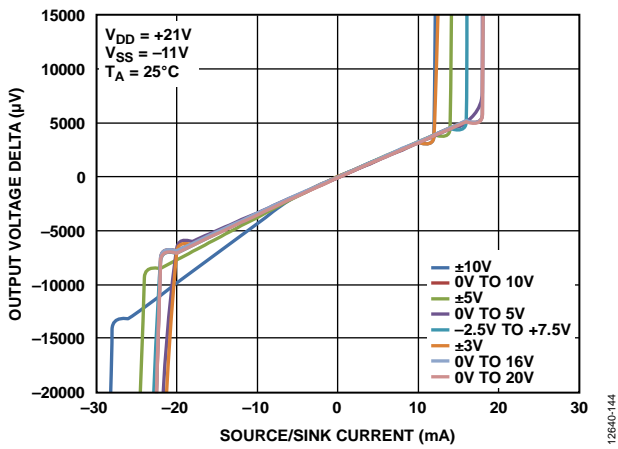

Figure 38. Source and Sink Capability of Output Amplifier with Negative Full Scale Loaded

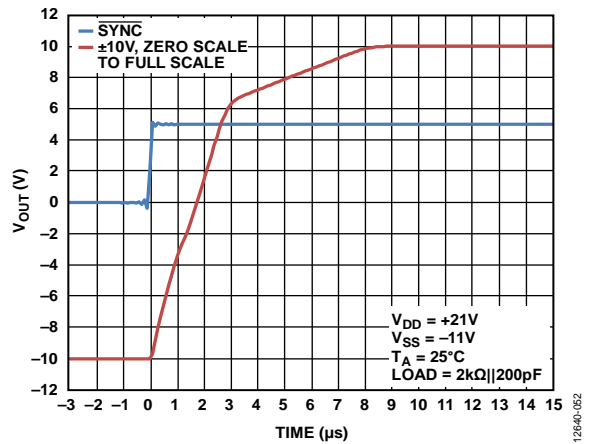

Figure 41. Full-Scale Settling Time (Rising Voltage Step), ±10 V Range

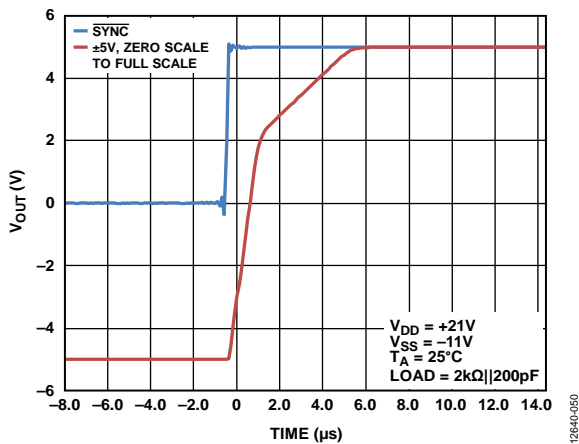

Figure 39. Full-Scale Settling Time (Rising Voltage Step), ±5 V Range

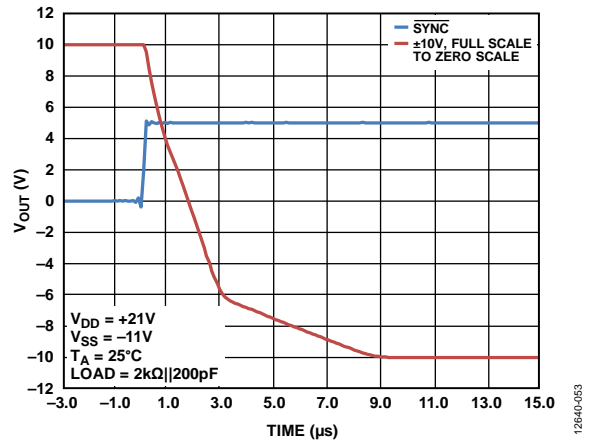

Figure 42. Full-Scale Settling Time (Falling Voltage Step), ±10 V Range

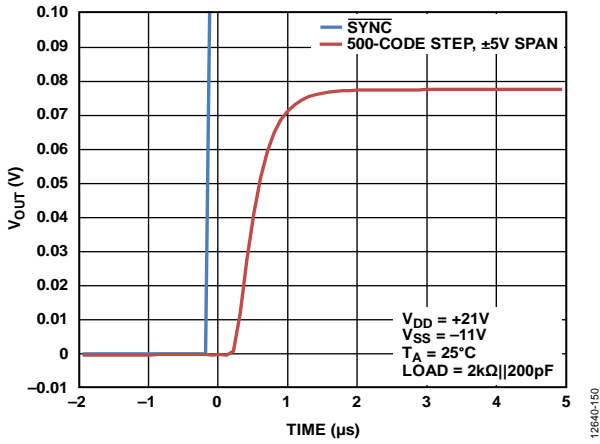

Figure 43. 500-Code Step Settling Time, ±5 V Range

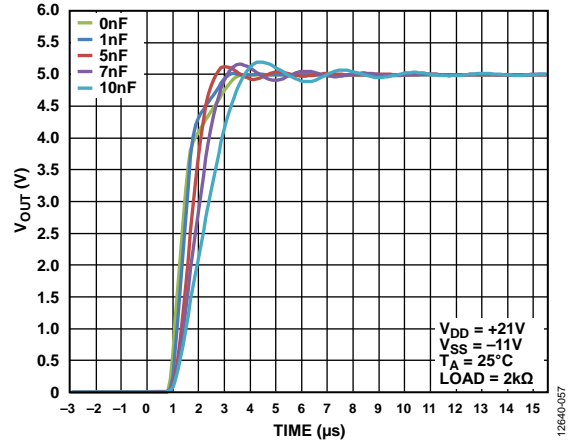

Figure 46. Settling Time vs. Capacitive Load, 0 V to 5 V Range

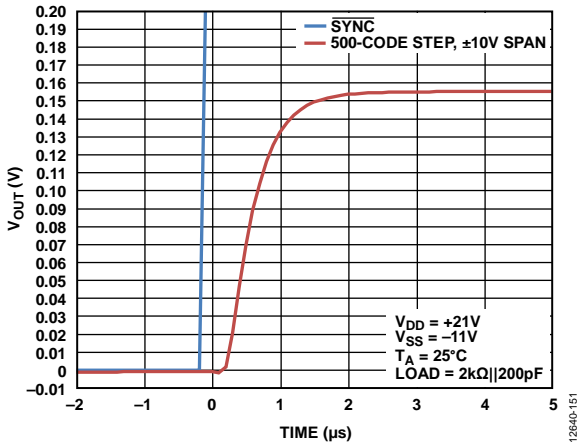

Figure 44. 500-Code Step Settling Time, ±10 V Range

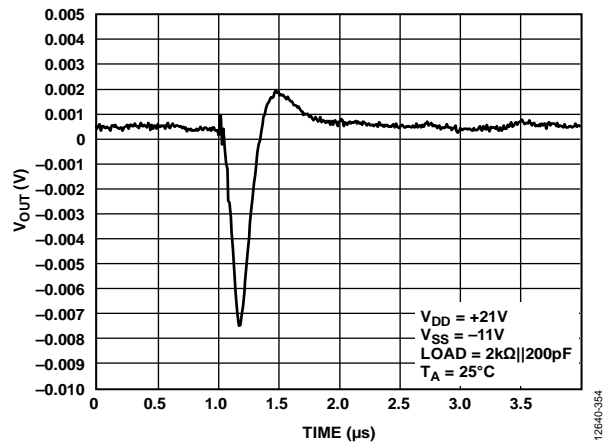

Figure 47. Digital-to-Analog Glitch Energy, 0 V to 5 V Range

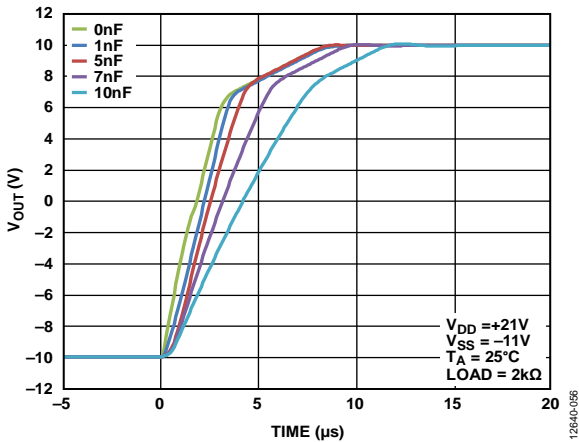

Figure 45. Settling Time vs. Capacitive Load, ±10 V Range

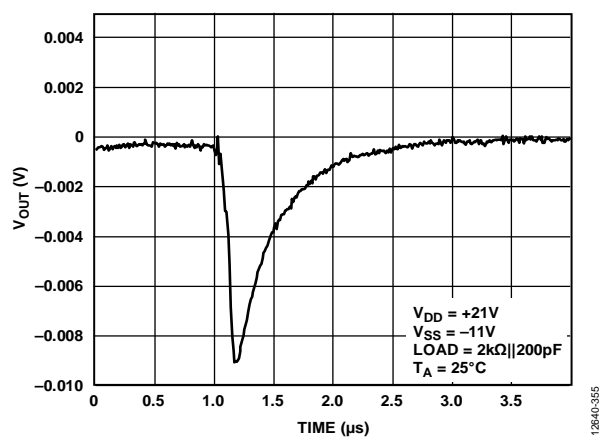

Figure 48. Digital-to-Analog Glitch Energy, ±10 V Range

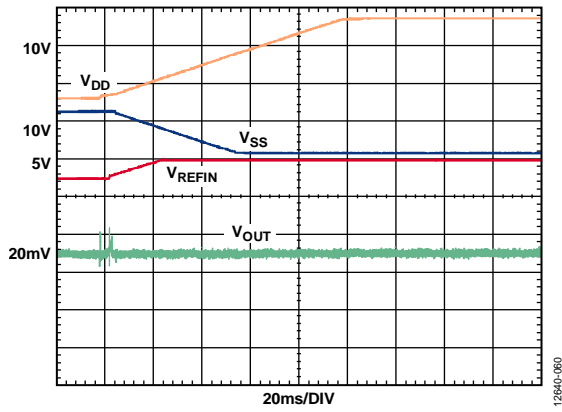

Figure 49. Power-Up Glitch

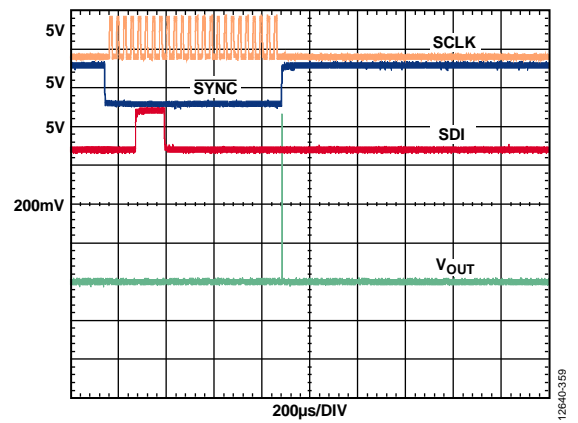

Figure 52. Software Full Reset Glitch from Zero Scale with Output Loaded, 0V to 5V Range

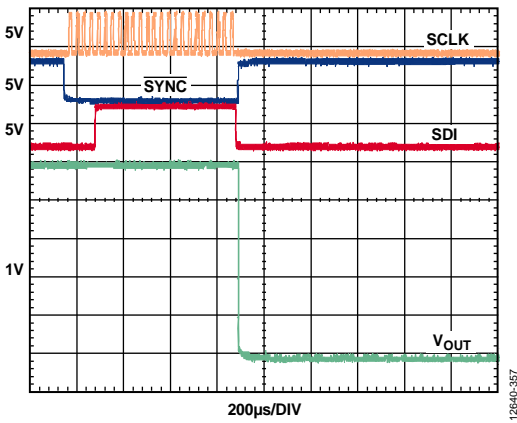

Figure 50. Software Full Reset Glitch from Full Scale with Output Loaded, 0V to 5V Range

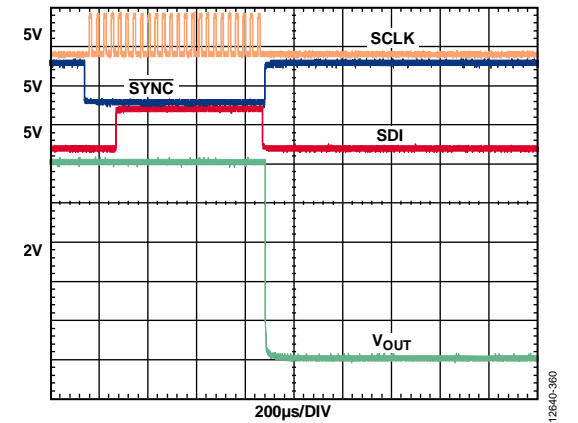

Figure 53. Software Full Reset Glitch from Full Scale with Output Loaded, ±10V Range

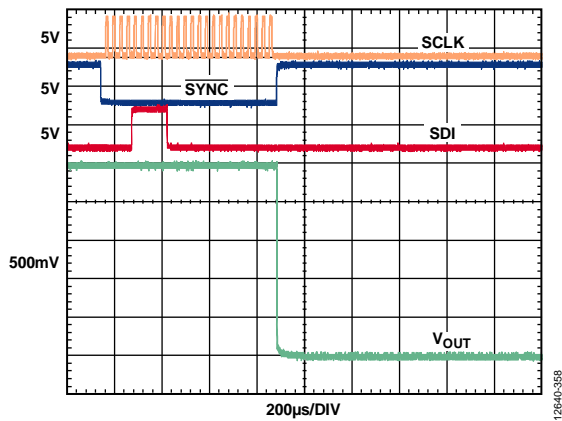

Figure 51. Software Full Reset Glitch from Midscale with Output Loaded, 0V to 5V Range

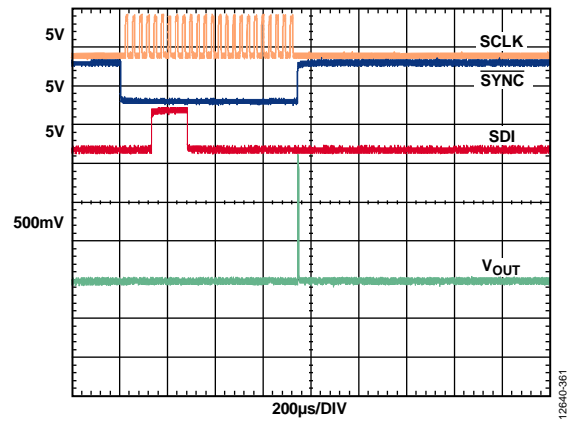

Figure 54. Software Full Reset Glitch from Midscale with Output Loaded, ±10V Range

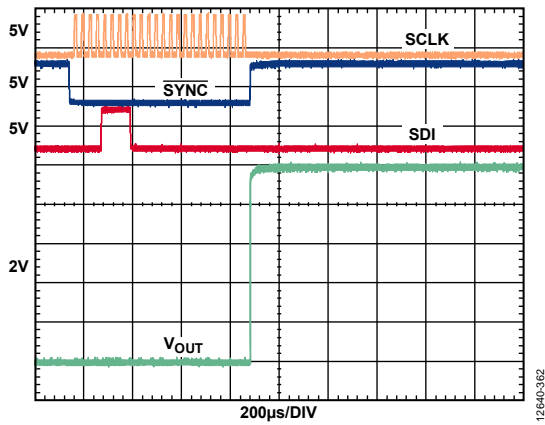

Figure 55. Software Full Reset Glitch from Zero Scale with Output Loaded,  $\pm 10$  V Range

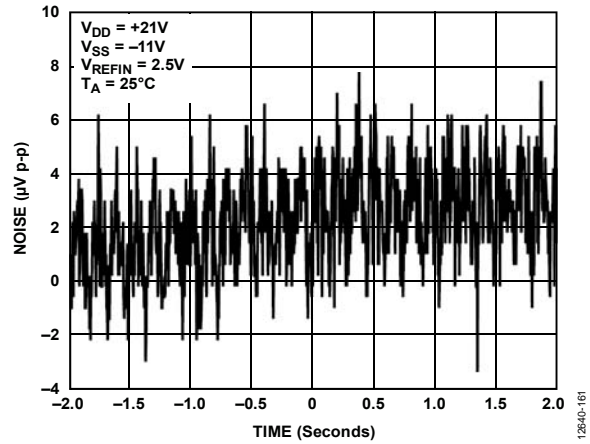

Figure 58. Peak-to-Peak Noise (Voltage Output Noise), 0.1 Hz to 10 Hz Bandwidth

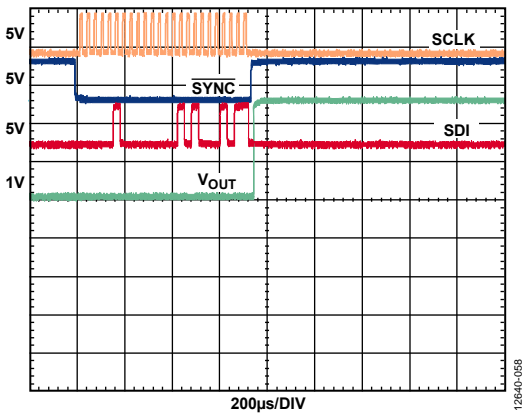

Figure 56. Output Range Change Glitch, 0 V to 5 V Range

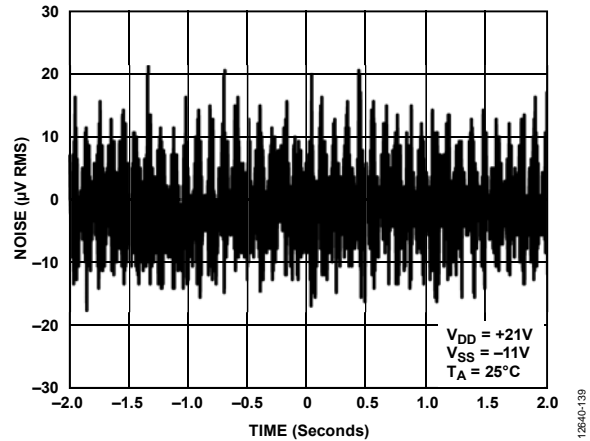

Figure 59. Peak-to-Peak Noise (Voltage Output Noise), 100 kHz Bandwidth

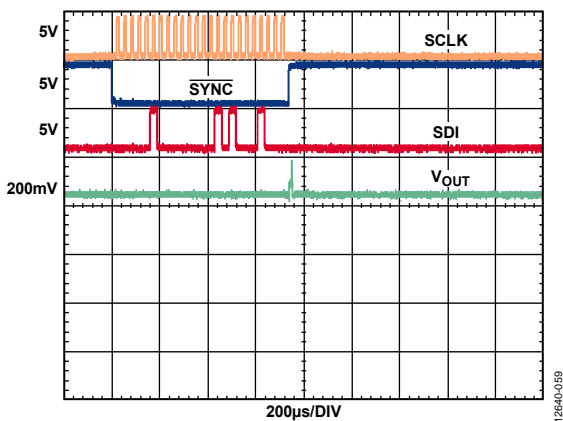

Figure 57. Output Range Change Glitch,  $\pm 10$  V Range

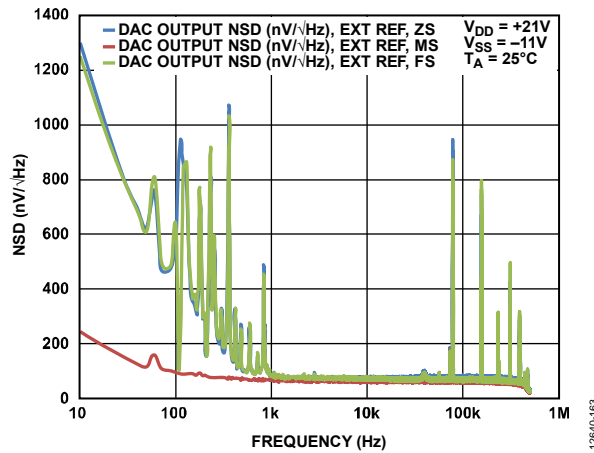

Figure 60. DAC Output Noise Spectral Density vs. Frequency,  $\pm 10$  V Range

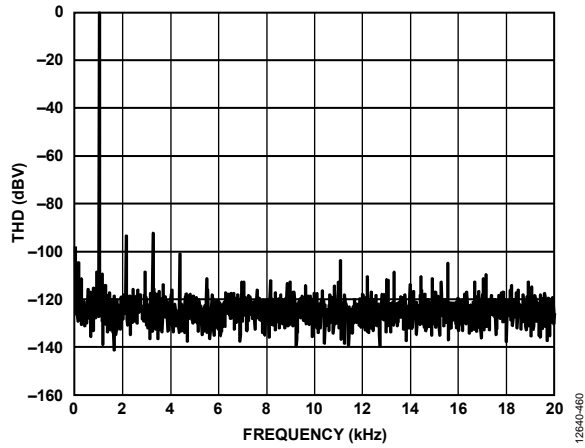

Figure 61. Total Harmonic Distortion at 1 kHz

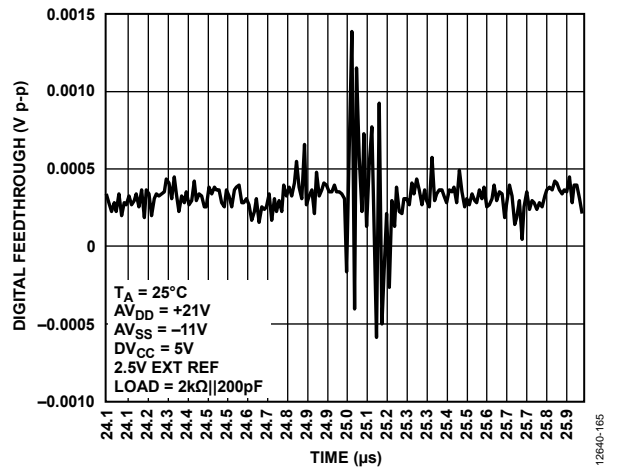

Figure 62. Digital Feedthrough

## TERMINOLOGY

### Total Unadjusted Error (TUE)

Total unadjusted error is a measure of the output error taking all the various errors into account, namely INL error, offset error, gain error, and output drift over supplies, temperature, and time. TUE is expressed in % FSR.

### Relative Accuracy or Integral Nonlinearity (INL)

For the DAC, relative accuracy, or integral nonlinearity, is a measure of the maximum deviation, in LSB, from a straight line passing through the endpoints of the DAC transfer function. A typical INL error vs. DAC code plot is shown in Figure 7.

### Differential Nonlinearity (DNL)

Differential nonlinearity is the difference between the measured change and the ideal 1 LSB change between any two adjacent codes. A specified differential nonlinearity of  $\pm 1$  LSB maximum ensures monotonicity. This DAC is guaranteed monotonic. A typical DNL error vs. code plot is shown in Figure 11.

### Monotonicity

A DAC is monotonic if the output either increases or remains constant for increasing digital input code. The AD5761/AD5721 are monotonic over their full operating temperature range.

### Bipolar Zero Error

Bipolar zero error is the deviation of the analog output from the ideal half-scale output of 0 V when the DAC register is loaded with 0x8000 (straight binary coding) or 0x0000 (twos complement coding) for the AD5761/AD5721.

### Bipolar Zero Temperature Coefficient (TC)

Bipolar zero TC is a measure of the change in the bipolar zero error with a change in temperature. It is expressed in  $\mu\text{V}/^\circ\text{C}$ .

### Zero-Scale Error

Zero-scale error is the error in the DAC output voltage when 0x0000 (straight binary coding) or 0x8000 (twos complement coding) is loaded to the DAC register. Ideally, the output voltage is negative full scale. A plot of zero-scale error vs. temperature is shown in Figure 21.

### Zero-Scale Error Temperature Coefficient (TC)

Zero-scale error TC is a measure of the change in zero-scale error with a change in temperature. It is expressed in  $\mu\text{V}/^\circ\text{C}$ .

### Offset Error

Offset error is a measure of the difference between  $V_{\text{OUT}}$  (actual) and  $V_{\text{OUT}}$  (ideal) expressed in mV in the linear region of the transfer function.

### Offset Error Temperature Coefficient (TC)

Offset error TC is a measurement of the change in offset error with a change in temperature. It is expressed in  $\mu\text{V}/^\circ\text{C}$ .

### Gain Error

Gain error is a measure of the span error of the DAC. It is the deviation in slope of the DAC transfer characteristic from the ideal expressed in % FSR. A plot of gain error vs. temperature is shown in Figure 24.

### Gain Error Temperature Coefficient (TC)

Gain error TC is a measure of the change in gain error with changes in temperature. It is expressed in ppm FSR/ $^\circ\text{C}$ .

### DC Power Supply Rejection Ratio (DC PSRR)

DC power supply rejection ratio is a measure of the rejection of the output voltage to dc changes in the power supplies applied to the DAC. It is measured for a given dc change in power supply voltage and is expressed in mV/V.

### AC Power Supply Rejection Ratio (AC PSRR)

AC power supply rejection ratio is a measure of the rejection of the output voltage to ac changes in the power supplies applied to the DAC. It is measured for a given amplitude and frequency change in power supply voltage and is expressed in decibels.

### Output Voltage Settling Time

Output voltage settling time is the amount of time it takes for the output to settle to a specified level for a full-scale input change. Full-scale settling time is shown in Figure 39 to Figure 42.

### Digital-to-Analog Glitch Impulse

Digital-to-analog glitch impulse is the impulse injected into the analog output when the input code in the DAC register changes state. It is normally specified as the area of the glitch in nV-sec and is measured when the digital input code is changed by 1 LSB at the major carry transition (see Figure 47 and Figure 48).

### Glitch Impulse Peak Amplitude

Glitch impulse peak amplitude is the peak amplitude of the impulse injected into the analog output when the input code in the DAC register changes state. It is specified as the amplitude of the glitch in mV and is measured when the digital input code is changed by 1 LSB at the major carry transition.

### Digital Feedthrough

Digital feedthrough is a measure of the impulse injected into the analog output of the DAC from the digital inputs of the DAC but is measured when the DAC output is not updated. It is specified in nV-sec and measured with a full-scale code change on the data bus.

### Noise Spectral Density

Noise spectral density is a measurement of the internally generated random noise characterized as a spectral density (nV/ $\sqrt{\text{Hz}}$ ). It is measured by loading the DAC to full scale and measuring noise at the output. It is measured in nV/ $\sqrt{\text{Hz}}$ . A plot of noise spectral density is shown in Figure 60.

### Total Harmonic Distortion (THD)

THD is the ratio of the rms sum of harmonics to the fundamental.

For the AD5761/AD5721, it is defined as

$$\text{THD (dB)} = 20 \times \log \frac{\sqrt{V_2^2 + V_3^2 + V_4^2 + V_5^2 + V_6^2}}{V_1}$$

where:

$V_1$  is the rms amplitude of the fundamental.

$V_2$ ,  $V_3$ ,  $V_4$ ,  $V_5$ , and  $V_6$  are the rms amplitudes of the second through the sixth harmonics.

## THEORY OF OPERATION

### DIGITAL-TO-ANALOG CONVERTER

The AD5761/AD5721 are single channel 16-bit/12-bit voltage output DACs. The AD5761/AD5721 output ranges are software selectable and can be configured as follows:

- Unipolar output voltage: 0 V to 5 V, 0 V to 10 V, 0 V to 16 V, 0 V to 20 V
- Bipolar output voltage: -2.5 V to +7.5 V, ±3 V, ±5 V, ±10 V

Data is written to the AD5761/AD5721 in a 24-bit word format via a 4-wire digital interface that is serial peripheral interface (SPI) compatible. The devices also offer an SDO pin to facilitate daisy-chaining and readback.

### TRANSFER FUNCTION

The input coding to the DAC can be straight binary or twos complement (bipolar ranges case only). Therefore, the transfer function is given by

$$V_{OUT} = V_{REF} \times \left[ \left( M \times \frac{D}{2^N} \right) - C \right]$$

where:

$V_{REF}$  is 2.5 V.

$M$  is the slope for a given output range (see Table 7).

$D$  is the decimal equivalent of the code loaded to the DAC register as follows:

0 to 4095 for the 12-bit device.

0 to 65,535 for the 16-bit device.

$N$  is the number of bits.  $N$  is 12 for the AD5721 and 16 for the AD5761.

$C$  is the offset for a given output range (see Table 7).

**Table 7. M and C Values for Various Output Ranges**

Range	M	C
±10 V	8	4
±5 V	4	2
±3 V	2.4	1.2
-2.5 V to +7.5 V	4	1
0 V to 20 V	8	0
0 V to 16 V	6.4	0
0 V to 10 V	4	0
0 V to 5 V	2	0

### DAC ARCHITECTURE

The DAC architecture consists of an R-2R DAC followed by an output buffer amplifier. Figure 63 shows a block diagram of the DAC architecture. Note that the reference input is buffered prior to being applied to the DAC.

The output voltage range obtained from the configurable output amplifier is selected by writing to the 3 LSBs, (RA[2:0]), in the control register.

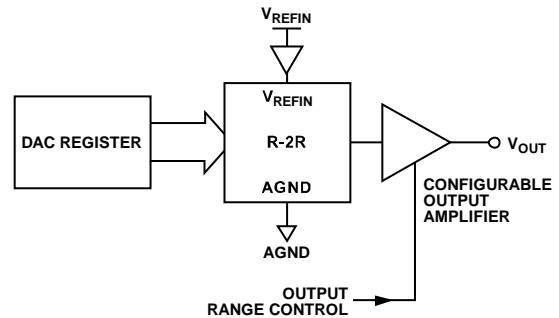

Figure 63. DAC Architecture

### R-2R DAC

The architecture of the AD5761/AD5721 consists of two matched DAC sections. A simplified circuit diagram is shown in Figure 64. The six MSBs of the 16-bit data-word are decoded to drive 63 switches, E0 to E62, whereas the remaining 10 bits of the data-word drive the S0 to S9 switches of a 10-bit voltage mode R-2R ladder network.

The code loaded into the DAC register determines which arms of the ladder are switched between  $V_{REFIN}$  and ground (AGND). The output voltage is taken from the end of the ladder and amplified afterwards to provide the selected output voltage.

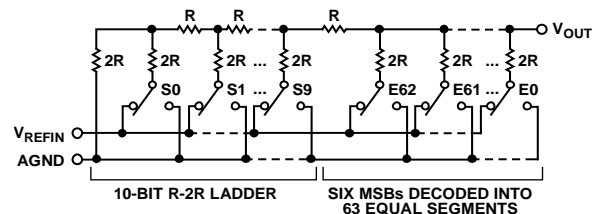

Figure 64. DAC Ladder Structure

### Reference Buffer

The AD5761/AD5721 operate with an external reference. The reference input has an input range of 2 V to 3 V with 2.5 V for specified performance. This input voltage is then buffered before it is applied to the DAC core.

### DAC Output Amplifier

The output amplifier is capable of generating both unipolar and bipolar output voltages. It is capable of driving a load of 2 kΩ in parallel with 1 nF to AGND. The source and sink capabilities of the output amplifier are shown in Figure 37.

## SERIAL INTERFACE

The AD5761/AD5721 4-wire ( $\overline{\text{SYNC}}$ , SCLK, SDI, and SDO) digital interface is SPI compatible. The write sequence begins after bringing the  $\overline{\text{SYNC}}$  line low, maintaining this line low until the complete data-word is loaded from the SDI pin. Data is loaded in at the SCLK falling edge transition (see Figure 2). When  $\overline{\text{SYNC}}$  is brought high again, the serial data-word is decoded according to the instructions in Table 10. The AD5761/AD5721 contain an SDO pin to allow the user to daisy-chain multiple devices together or to read back the contents of the registers.

### Standalone Operation

The serial interface works with both a continuous and noncontinuous serial clock. A continuous SCLK source can be used only when  $\overline{\text{SYNC}}$  is held low for the correct number of clock cycles.

In gated clock mode, a burst clock containing the exact number of clock cycles must be used, and  $\overline{\text{SYNC}}$  must be taken high after the final clock to latch the data. The first falling edge of  $\overline{\text{SYNC}}$  starts the write cycle. Exactly 24 falling clock edges must be applied to SCLK before  $\overline{\text{SYNC}}$  is brought high again. If  $\overline{\text{SYNC}}$  is brought high before the 24th falling SCLK edge, the data written is invalid. If more than 24 falling SCLK edges are applied before  $\overline{\text{SYNC}}$  is brought high, the input data is also invalid.

The input shift register is updated on the rising edge of  $\overline{\text{SYNC}}$ . For another serial transfer to take place,  $\overline{\text{SYNC}}$  must be brought low again. After the end of the serial data transfer, data is automatically transferred from the input shift register to the addressed register. When the write cycle is complete, the output can be updated by taking  $\overline{\text{LDAC}}$  low while  $\overline{\text{SYNC}}$  is high.

### Readback Operation

The contents of the input, DAC, and control registers can be read back via the SDO pin. Figure 4 shows how the registers are decoded. After a register has been addressed for a read, the next 24 clock cycles clock the data out on the SDO pin. The clocks must be applied while  $\overline{\text{SYNC}}$  is low. When  $\overline{\text{SYNC}}$  is returned high, the SDO pin is placed in tristate. For a read of a single register, the no operation (NOP) function clocks out the data. Alternatively, if more than one register is to be read, the data of the first register to be addressed clocks out at the same time that the second register to be read is being addressed. The SDO pin must be enabled to complete a readback operation. The SDO pin is enabled by default.

### Daisy-Chain Operation

For systems that contain several devices, use the SDO pin to daisy-chain several devices together. Daisy-chain mode is useful in system diagnostics and in reducing the number of serial interface lines. The first falling edge of  $\overline{\text{SYNC}}$  starts the write cycle. SCLK is continuously applied to the input shift register when  $\overline{\text{SYNC}}$  is low. If more than 24 clock pulses are applied, the data ripples out of the shift register and appears on the SDO line. This data is clocked out on the rising edge of SCLK and is valid on the falling edge.

By connecting the SDO of the first device to the SDI input of the next device in the chain, a multidevice interface is constructed. Each device in the system requires 24 clock pulses. Therefore, the total number of clock cycles must equal  $24 \times N$ , where N is the total number of AD5761/AD5721 devices in the chain. When the serial transfer to all devices is complete,  $\overline{\text{SYNC}}$  is taken high, which latches the input data in each device in the daisy chain and prevents any further data from being clocked into the input shift register.

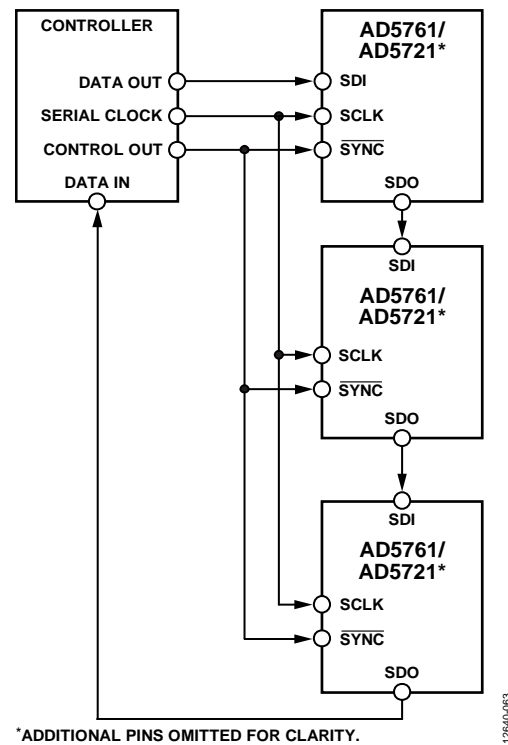

Figure 65. Daisy-Chain Block Diagram

## HARDWARE CONTROL PINS

### Load DAC Function ( $\overline{\text{LDAC}}$ )

After data transfers into the input register of the DAC, there are two ways to update the DAC register and DAC output. Depending on the status of both  $\overline{\text{SYNC}}$  and  $\overline{\text{LDAC}}$ , one of two update modes is selected: synchronous DAC update or asynchronous DAC update.

### Synchronous DAC Update

In synchronous DAC update mode,  $\overline{\text{LDAC}}$  is held low while data is being clocked into the input shift register. The DAC output is updated on the rising edge of  $\overline{\text{SYNC}}$ .

**Asynchronous DAC Update**

In asynchronous DAC update mode,  $\overline{\text{LDAC}}$  is held high while data is being clocked into the input shift register. The DAC output is asynchronously updated by taking  $\overline{\text{LDAC}}$  low after  $\overline{\text{SYNC}}$  is taken high. The update then occurs on the falling edge of  $\overline{\text{LDAC}}$ .

**Reset Function ( $\overline{\text{RESET}}$ )**

The AD5761/AD5721 can be reset to its power-on state by two means: either by asserting the  $\overline{\text{RESET}}$  pin or by using the software full reset registers (see Table 26).

**Asynchronous Clear Function ( $\overline{\text{CLEAR}}$ )**

The  $\overline{\text{CLEAR}}$  pin is a falling edge active input that allows the output to be cleared to a user defined value. The clear code value is programmed by writing to Bit 10 and Bit 9 in the control register (see Table 11 and Table 12). It is necessary to maintain  $\overline{\text{CLEAR}}$  low for a minimum amount of time to complete the operation (see Figure 2). When the  $\overline{\text{CLEAR}}$  signal is returned high, the output remains at the clear value until a new value is loaded to the DAC register.

**Alert Function ( $\overline{\text{ALERT}}$ )**

When the  $\overline{\text{ALERT}}$  pin is asserted low, a readback from the control register is required to clarify whether a short-circuit or brownout condition occurred, depending on the values of Bit 12 and Bit 11, SC and BO bits, respectively (see Table 15 and Table 16). If neither of these conditions occurred, the temperature exceeded approximately 150°C.

The  $\overline{\text{ALERT}}$  pin is low during power-up, a software full reset, or a hardware reset. After the first write to the control register to configure the DAC, the  $\overline{\text{ALERT}}$  pin is asserted high.

In the event of the die temperature exceeding approximately 150°C, the  $\overline{\text{ALERT}}$  pin is low and the value of the ETS bit determines the state of the digital supply of the device, whether the internal digital supply is powered on or powered down. If the ETS bit is set to 0, the internal digital supply is powered on when the internal die temperature exceeds approximately 150°C. If the ETS bit is set to 1, the internal digital supply is powered down when the internal die temperature exceeds approximately 150°C and the device becomes nonfunctional (see Table 11 and Table 12).

The AD5761/AD5721 temperature at power-up must be less than 150°C for proper operation of the devices.

## REGISTER DETAILS

### INPUT SHIFT REGISTER

The input shift register is 24 bits wide. Data is loaded into the device MSB first as a 24-bit word under the control of a serial clock input, SCLK, which can operate at rates of up to 50 MHz. The input shift register consists of three don't care bits, one fixed value bit (DB20 = 0), four address bits, and a 16-bit or 12-bit data-word as shown in Table 8 and Table 9, respectively.

Table 8. AD5761 16-Bit Input Shift Register Format

MSB									LSB
DB23	DB22	DB21	DB20	DB19	DB18	DB17	DB16	DB15 to DB0	
X <sup>1</sup>	X <sup>1</sup>	X <sup>1</sup>	0	Register address				Register data	

<sup>1</sup> X means don't care.

Table 9. AD5721 12-Bit Input Shift Register Format

MSB									LSB
DB23	DB22	DB21	DB20	DB19	DB18	DB17	DB16	DB15 to DB4	DB3 to DB0
X <sup>1</sup>	X <sup>1</sup>	X <sup>1</sup>	0	Register address				Register data	XXXX <sup>1</sup>

<sup>1</sup> X means don't care.

Table 10. Input Shift Register Commands

Register Address				Command
DB19	DB18	DB17	DB16	
0	0	0	0	No operation
0	0	0	1	Write to input register (no update)
0	0	1	0	Update DAC register from input register
0	0	1	1	Write and update DAC register
0	1	0	0	Write to control register
0	1	0	1	No operation
0	1	1	0	No operation
0	1	1	1	Software data reset
1	0	0	0	Reserved
1	0	0	1	Disable daisy-chain functionality
1	0	1	0	Readback input register
1	0	1	1	Readback DAC register
1	1	0	0	Readback control register
1	1	0	1	No operation
1	1	1	0	No operation
1	1	1	1	Software full reset

### CONTROL REGISTER

The control register controls the mode of operation of the AD5761/AD5721. The control register options are shown in Table 11 and Table 12.

On power-up, after a full reset, or after a hardware reset, the output of the DAC is clamped to ground through a 1 kΩ resistor and the output buffer remains in power-down mode. A write to the control register is required to configure the device, remove the clamp to ground, and power up the output buffer.

When the DAC output range is reconfigured during operation, a software full reset command (see Table 26) must be written to the device before writing to the control register.

Table 11. Write to Control Register

MSB										LSB
DB[23:21]	DB20	DB[19:16]	DB[15:11]	DB[10:9]	DB8	DB7	DB6	DB5	DB[4:3]	DB[2:0]
XXX <sup>1</sup>	0	Register address		Register data						
XXX <sup>1</sup>	0	0100	XXXXX <sup>1</sup>	CV[1:0]	OVR	B2C	ETS	0	PV[1:0]	RA[2:0]

<sup>1</sup> X means don't care.

Table 12. Control Register Functions

Bit Name	Description
CV[1:0]	CLEAR voltage selection. 00: zero scale. 01: midscale. 10, 11: full scale.
OVR	5% overrange. 0: 5% overrange disabled. 1: 5% overrange enabled.
B2C	Bipolar range. 0: DAC input for bipolar output range is straight binary coded. 1: DAC input for bipolar output range is twos complement coded.
ETS	Thermal shutdown alert. The alert may not work correctly if the device powers on with temperature conditions >150°C (greater than the maximum rating of the device). 0: internal digital supply does not power down if die temperature exceeds 150°C. 1: internal digital supply powers down if die temperature exceeds 150°C.
PV[1:0]	Power-up voltage. 00: zero scale. 01: midscale. 10, 11: full scale.
RA[2:0]	Output range. Before an output range configuration, the device must be reset. 000: -10 V to +10 V. 001: 0 V to +10 V. 010: -5 V to +5 V. 011: 0 V to 5 V. 100: -2.5 V to +7.5 V. 101: -3 V to +3 V. 110: 0 V to 16 V. 111: 0 V to 20 V.

Table 13. Bipolar Output Range Possible Codes

Straight Binary	Decimal Code	Twos Complement
1111	+7	0111
1110	+6	0110
1101	+5	0101
1100	+4	0100
1011	+3	0011
1010	+2	0010
1001	+1	0001
1000	0	0000
0111	-1	1111
0110	-2	1110
0101	-3	1101
0100	-4	1100
0011	-5	1011
0010	-6	1010
0001	-7	1001
0000	-8	1000

**READBACK CONTROL REGISTER**

The readback control register operation provides the contents of the control register by setting the register address to 1100. Table 14 outlines the 24-bit shift register for this command, where the last 16 bits are don't care bits.

During the next command, the control register contents are shifted out of the SDO pin with the MSB shifted out first. Table 15 outlines the 24-bit data read from the SDO pin, where DB23 is the first bit shifted out.

**Table 14. Readback Control Register, 24-Bit Shift Register to the SDI Pin**

MSB			LSB
DB[23:21]	DB20	DB[19:16]	DB[15:10]
XXX <sup>1</sup>	0	Register address	Register data
XXX <sup>1</sup>	0	1100	Don't care

<sup>1</sup> X means don't care.

**Table 15. Readback Control Register, 24-Bit Data Read from the SDO Pin**

MSB												LSB	
DB[23:21]	DB20	DB[19:16]	DB[15:13]	DB12	DB11	DB[10:9]	DB8	DB7	DB6	DB5	DB[4:3]	DB[2:0]	
XXX <sup>1</sup>	0	Register address	Register data										
XXX <sup>1</sup>	0	1100	XXXXX <sup>1</sup>	SC	BO	CV[1:0]	OVR	B2C	ETS	X <sup>1</sup>	PV[1:0]	RA[2:0]	

<sup>1</sup> X means don't care.

**Table 16. Readback Control Register Bit Descriptions**

Bit Name	Description
SC	Short-circuit condition. The SC bit is reset at every control register write. 0: no short-circuit condition detected. 1: short-circuit condition detected.
BO	Brownout condition. The BO bit is reset at every control register write. 0: no brownout condition detected. 1: brownout condition detected.

**UPDATE DAC REGISTER FROM INPUT REGISTER**

The update DAC register function loads the DAC register with the data saved in the input register, and updates the DAC output voltage. This operation is equivalent to a software LDAC. Table 17 outlines how data is written to the DAC register.

**Table 17. Update DAC Register from Input Register**

MSB								LSB
DB23	DB22	DB21	DB20	DB19	DB18	DB17	DB16	DB15 to DB0
X <sup>1</sup>	X <sup>1</sup>	X <sup>1</sup>	0	Register address				Register data
X <sup>1</sup>	X <sup>1</sup>	X <sup>1</sup>	0	0010				Don't care

<sup>1</sup> X means don't care.

**READBACK DAC REGISTER**

The readback DAC register operation provides the contents of the DAC register by setting the register address to 1011. Table 18 outlines the 24-bit shift register for this command. During the next command, the DAC register contents are shifted out of the SDO pin with the MSB shifted out first. Table 19 outlines the 24-bit data read from the SDO pin, where DB23 is the first bit shifted out.

**Table 18. Readback DAC Register, 24-Bit Shift Register to SDI Pin**

MSB								LSB
DB23	DB22	DB21	DB20	DB19	DB18	DB17	DB16	DB15 to DB0
X <sup>1</sup>	X <sup>1</sup>	X <sup>1</sup>	0	Register address				Register data
X <sup>1</sup>	X <sup>1</sup>	X <sup>1</sup>	0	1011				Don't care

<sup>1</sup> X means don't care.

Table 19. Readback DAC Register, 24-Bit Data Read from SDO Pin

MSB								LSB
DB23	DB22	DB21	DB20	DB19	DB18	DB17	DB16	DB15 to DB0
X <sup>1</sup>	X <sup>1</sup>	X <sup>1</sup>	0	Register address				Register data
X <sup>1</sup>	X <sup>1</sup>	X <sup>1</sup>	0	1011				Data read from DAC register

<sup>1</sup> X means don't care.

## WRITE AND UPDATE DAC REGISTER

The write and update DAC register (Register Address 0011) updates the input register and the DAC register with the entered data-word from the input shift register, irrespective of the state of LDAC.

Setting the register address to 0001 writes the input register with the data from the input shift register, clocked in MSB first on the SDI pin.

Table 20. Write and Update DAC Register

MSB								LSB
DB23	DB22	DB21	DB20	DB19	DB18	DB17	DB16	DB15 to DB0
X <sup>1</sup>	X <sup>1</sup>	X <sup>1</sup>	0	Register address				Register data
X <sup>1</sup>	X <sup>1</sup>	X <sup>1</sup>	0	0001				Data loaded
X <sup>1</sup>	X <sup>1</sup>	X <sup>1</sup>	0	0011				Data loaded

<sup>1</sup> X means don't care.

## READBACK INPUT REGISTER

The readback input register operation provides the contents of the input register by setting the register address to 1010. Table 21 outlines the 24-bit shift register for this command. During the next command, the input register contents are shifted out of the SDO pin with MSB shifted out first. Table 22 outlines the 24-bit data read from the SDO pin, where DB23 is the first bit shifted out.

Table 21. Read Back Input Register, 24-Bit Shift Register to the SDI Pin

MSB								LSB
DB23	DB22	DB21	DB20	DB19	DB18	DB17	DB16	DB15 to DB0
X <sup>1</sup>	X <sup>1</sup>	X <sup>1</sup>	0	Register address				Register data
X <sup>1</sup>	X <sup>1</sup>	X <sup>1</sup>	0	1010				Don't care

<sup>1</sup> X means don't care.

Table 22. Readback Input Register, 24-Bit Data Read from the SDO Pin

MSB								LSB
DB23	DB22	DB21	DB20	DB19	DB18	DB17	DB16	DB15 to DB0
X <sup>1</sup>	X <sup>1</sup>	X <sup>1</sup>	0	Register address				Register data
X <sup>1</sup>	X <sup>1</sup>	X <sup>1</sup>	0	1010				Data read from input register

<sup>1</sup> X means don't care.

## DISABLE DAISY-CHAIN FUNCTIONALITY

The daisy-chain feature can be disabled to save the power consumed by the SDO buffer when this functionality is not required (see Table 23). When disabled, a readback request is not accepted because the SDO pin remains in tristate.

Table 23. Disable Daisy-Chain Functionality Register

MSB								LSB	
DB23	DB22	DB21	DB20	DB19	DB18	DB17	DB16	DB15 to DB1	DB0
X <sup>1</sup>	X <sup>1</sup>	X <sup>1</sup>	0	Register address				Register data	
X <sup>1</sup>	X <sup>1</sup>	X <sup>1</sup>	0	1001				Don't care	DDC

<sup>1</sup> X means don't care.

**Table 24. Disable Daisy-Chain Bit Description**

Bit Name	Description
DDC	DDC decides whether daisy-chain functionality is enabled or disabled for the device. By default, daisy-chain functionality is enabled. 0: daisy-chain functionality is enabled for the device. 1: daisy-chain functionality is disabled for the device.

**SOFTWARE DATA RESET**

The AD5761/AD5721 can be reset via software to zero scale, midscale, or full scale (see Table 25). The value to which the device is reset is specified by the PV1 and PV0 bits, which are set in the write to control register command (see Table 11 and Table 12).

**Table 25. Software Data Reset Register**

MSB								LSB
DB23	DB22	DB21	DB20	DB19	DB18	DB17	DB16	DB15 to DB0
X <sup>1</sup>	X <sup>1</sup>	X <sup>1</sup>	0	Register address				Register data
X <sup>1</sup>	X <sup>1</sup>	X <sup>1</sup>	0	0111				Don't care

<sup>1</sup> X means don't care.

**SOFTWARE FULL RESET**

The device can also be reset completely via software (see Table 26). When the register address is set to 1111, the device behaves in a power-up state, where the output is clamped to AGND and the output buffer is powered down. The user must write to the control register to configure the device, remove the 1 kΩ resistor clamp to ground, and power up the output buffer.

The software full reset command is also issued when the DAC output range is reconfigured during normal operation.

**Table 26. Software Full Reset Register**

MSB								LSB
DB23	DB22	DB21	DB20	DB19	DB18	DB17	DB16	DB15 to DB0
X <sup>1</sup>	X <sup>1</sup>	X <sup>1</sup>	0	Register address				Register data
X <sup>1</sup>	X <sup>1</sup>	X <sup>1</sup>	0	1111				Don't care

<sup>1</sup> X means don't care.

**NO OPERATION REGISTERS**

The no operation registers are ignored and do not vary the state of the device (see Table 27).

**Table 27. No Operation Registers**

MSB								LSB
DB23	DB22	DB21	DB20	DB19	DB18	DB17	DB16	DB15 to DB0
X <sup>1</sup>	X <sup>1</sup>	X <sup>1</sup>	0	Register address				Register data
X <sup>1</sup>	X <sup>1</sup>	X <sup>1</sup>	0	0000/0101/0110/1101/1110				Don't care

<sup>1</sup> X means don't care.

## APPLICATIONS INFORMATION

### TYPICAL OPERATING CIRCUIT

Figure 66 shows the typical operating circuit for the [AD5761/AD5721](#). The only external components needed for these precision 16-/12-bit DACs are decoupling capacitors, supply voltage, and an external reference. The integration of a reference buffer in the [AD5761/AD5721](#) results in overall savings in both cost and board space.

In Figure 66,  $V_{DD}$  is connected to 15 V and  $V_{SS}$  is connected to -15 V, but  $V_{DD}$  and  $V_{SS}$  can operate with supplies from 4.75 V to 30 V and from -16.5 V to 0 V, respectively.

#### Precision Voltage Reference Selection

An external reference is required for the [AD5761/AD5721](#). Take care in the selection of the same because any error in the voltage reference is reflected in the output of the device.

There are four possible sources of error to consider when choosing a voltage reference for high accuracy applications: initial accuracy, temperature coefficient of the output voltage, long-term drift, and output voltage noise.

Initial accuracy error on the output voltage of an external reference may lead to a full-scale error in the DAC. Therefore, to minimize these errors, a reference with low initial accuracy error specification is preferred. Choosing a reference with an output trim adjustment, such as the [ADR421](#), allows a system designer to trim system errors out by setting the reference voltage to a voltage other than the nominal. The trim adjustment can also be used at ambient temperature to trim out any error.

Long-term drift is a measure of how much the reference output voltage drifts over time. A reference with a tight long-term drift specification ensures that the overall solution remains relatively stable over its entire lifetime.

The temperature coefficient of a reference output voltage affects gain error and TUE. Choose a reference with a tight temperature coefficient specification to reduce the dependence of the DAC output voltage on ambient conditions.

In high accuracy applications, which have a relatively low noise budget, reference output voltage noise must be considered. It is important to choose a reference with as low an output noise voltage as practical for the system resolution that is required. Precision voltage references, such as the [ADR4525](#), produce low output noise in the 0.1 Hz to 10 Hz region. However, as the circuit bandwidth increases, filtering the output of the reference may be required to minimize the output noise.

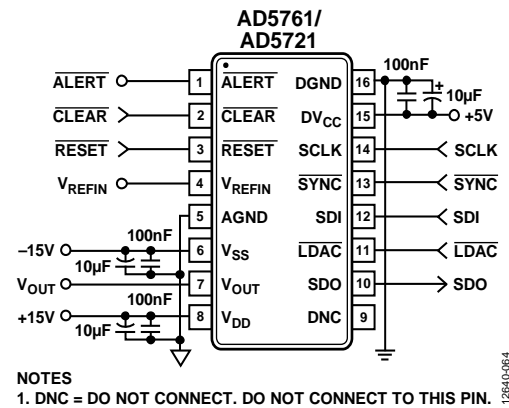

Figure 66. Typical Operating Circuit

### POWER SUPPLY CONSIDERATIONS

The [AD5761/AD5721](#) must be powered by the following three supplies to provide any of the eight output voltage ranges available on the DAC:  $V_{DD} = +21$  V,  $V_{SS} = -11$  V, and  $DV_{CC} = +5$  V.

For applications requiring optimal high power efficiency and low noise performance, it is recommended that the [ADP5070](#) switching regulator be used to convert the 5 V input rail into two intermediate rails (+23 V and -13 V). These intermediate rails are then postregulated by very low noise, low dropout (LDO) regulators ([ADP7142](#) and [ADP7182](#)). Figure 67 shows the recommended method.

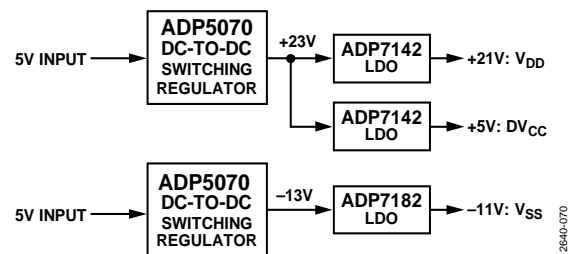

Figure 67. Postregulation by [ADP7142](#) and [ADP7182](#)

### EVALUATION BOARD

An evaluation board is available for the [AD5761R](#) to aid designers in evaluating the high performance of the device with minimum effort. This evaluation board can be used to evaluate the [AD5761/AD5721](#). The [AD5761R](#) evaluation kit includes a populated and tested [AD5761R](#) printed circuit board (PCB). The evaluation board interfaces to the USB port of a PC. Software is available with the evaluation board to allow the user to easily program the [AD5761R](#). The [EVAL-AD5761RSDZ](#) user guide gives full details on the operation of the evaluation board.

Table 28. Precision References Recommended for Use with the [AD5761/AD5721](#)

Part No.	Initial Accuracy (mV Maximum)	Long-Term Drift (ppm Typical)	Temperature Drift (ppm/°C Maximum)	0.1 Hz to 10 Hz Noise ( $\mu$ V p-p Typical)
<a href="#">ADR03</a>	$\pm 2.5$	50	3	6
<a href="#">ADR421</a>	$\pm 1$	50	3	1.75
<a href="#">ADR431</a>	$\pm 1$	40	3	3.5
<a href="#">ADR441</a>	$\pm 1$	50	3	1.2
<a href="#">ADR4525</a>	1	25	2	1.25

# OUTLINE DIMENSIONS

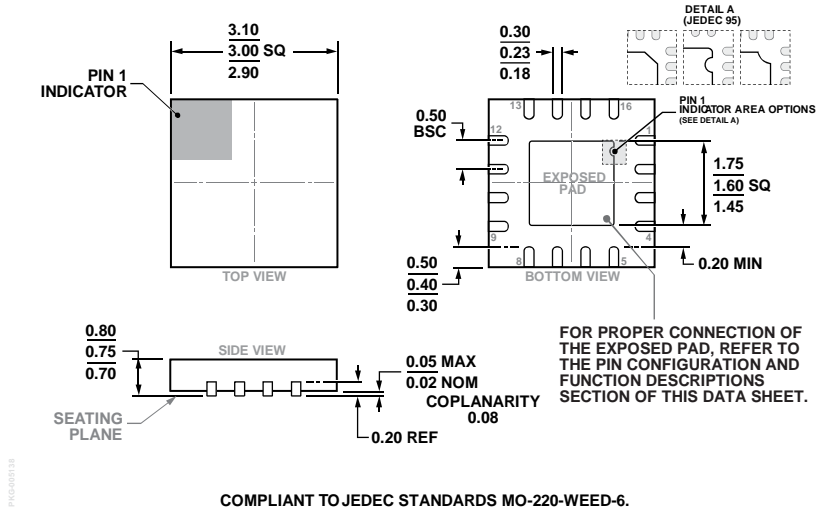

COMPLIANT TO JEDEC STANDARDS MO-220-WEED-6.

Figure 68. 16-Lead Lead Frame Chip Scale Package [LFCSP]  
3 mm x 3 mm Body and 0.75 mm Package Height  
(CP-16-22)

Dimensions shown in millimeters

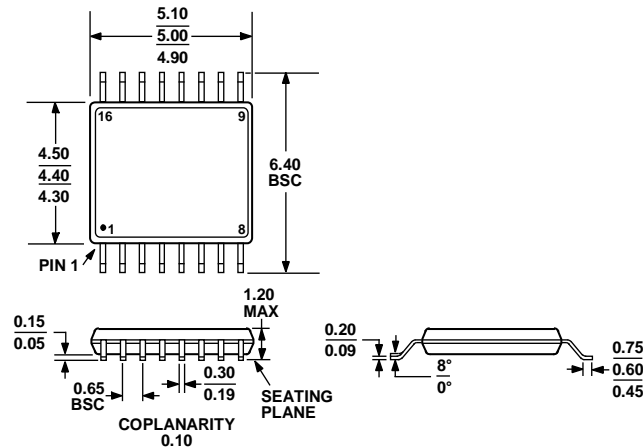

COMPLIANT TO JEDEC STANDARDS MO-153-AB

Figure 69. 16-Lead Thin Shrink Small Outline Package [TSSOP]  
(RU-16)

Dimensions shown in millimeters

## ORDERING GUIDE

Model <sup>1</sup>	Resolution (Bits)	Temperature Range	INL (LSB)	Package Description	Package Option	Marking Code
AD5721BCPZ-RL7	12	-40°C to +125°C	±0.5	16-Lead LFCSP	CP-16-22	DHP
AD5721BRUZ	12	-40°C to +125°C	±0.5	16-Lead TSSOP	RU-16	
AD5721BRUZ-RL7	12	-40°C to +125°C	±0.5	16-Lead TSSOP	RU-16	
AD5761ACPZ-RL7	16	-40°C to +125°C	±8	16-Lead LFCSP	CP-16-22	DN8
AD5761BCPZ-RL7	16	-40°C to +125°C	±2	16-Lead LFCSP	CP-16-22	DHQ
AD5761ARUZ	16	-40°C to +125°C	±8	16-Lead TSSOP	RU-16	
AD5761ARUZ-RL7	16	-40°C to +125°C	±8	16-Lead TSSOP	RU-16	
AD5761BRUZ	16	-40°C to +125°C	±2	16-Lead TSSOP	RU-16	
AD5761BRUZ-RL7	16	-40°C to +125°C	±2	16-Lead TSSOP	RU-16	

<sup>1</sup> Z = RoHS Compliant Part.

## Looking for pricing, stock, or lifecycle information?

Click below to explore more details on WIN SOURCE:

 [View AD5761ARUZ on WIN SOURCE](#)

 [Analog Devices Inc. Information](#)

## Optimize Your Supply Chain with WIN SOURCE Solutions

-  Global Sourcing Solution
-  Obsolete Management
-  Cost Control Management
-  Shortage Management
-  Alternative Solution
-  Excess Inventory Management