



THE DATASHEET OF AD7888ARUZ-REEL



FEATURES

Specified for V_{DD} of 2.7 V to 5.25 V
Flexible Power/Throughput Rate Management
Shutdown Mode: 1 μ A Max
Eight Single-Ended Inputs
**Serial Interface: SPI™/QSPI™/MICROWIRE™/DSP
 Compatible**
16-Lead Narrow SOIC and TSSOP Packages

APPLICATIONS

**Battery-Powered Systems (Personal Digital Assistants,
 Medical Instruments, Mobile Communications)**
Instrumentation and Control Systems
High-Speed Modems

GENERAL DESCRIPTION

The AD7888 is a high speed, low power, 12-bit ADC that operates from a single 2.7 V to 5.25 V power supply. The AD7888 is capable of a 125 kSPS throughput rate. The input track-and-hold acquires a signal in 500 ns and features a single-ended sampling scheme. The AD7888 contains eight single-ended analog inputs, AIN1 through AIN8. The analog input on each of these channels is from 0 to V_{REF} . The part is capable of converting full power signals up to 2.5 MHz.

The AD7888 features an on-chip 2.5 V reference that can be used as the reference source for the A/D converter. The REF IN/REF OUT pin allows the user access to this reference. Alternatively, this pin can be overdriven to provide an external reference voltage for the AD7888. The voltage range for this external reference is from 1.2 V to V_{DD} .

CMOS construction ensures low power dissipation of typically 2 mW for normal operation and 3 μ W in power-down mode. The part is available in a 16-lead narrow body small outline (SOIC) and a 16-lead thin shrink small outline (TSSOP) package.

FUNCTIONAL BLOCK DIAGRAM

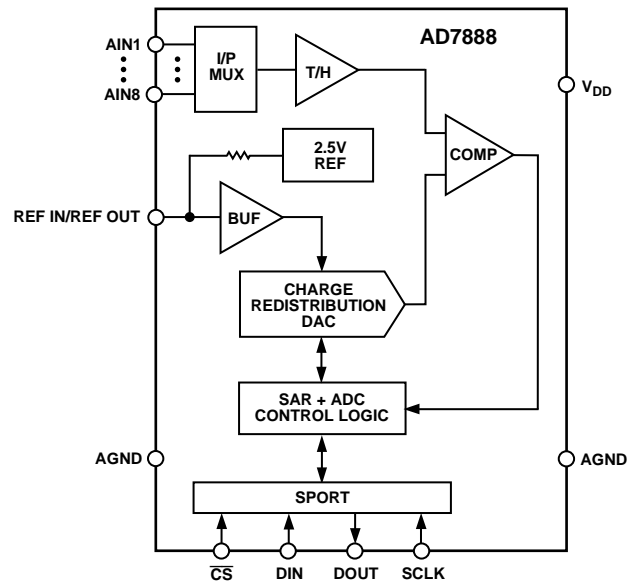

PRODUCT HIGHLIGHTS

1. Smallest 12-bit 8-channel ADC; 16-lead TSSOP is the same area as an 8-lead SOIC and less than half the height.
2. Lowest Power 12-bit 8-channel ADC.
3. Flexible power management options including automatic power-down after conversion.
4. Analog input range from 0 V to V_{REF} (V_{DD}).
5. Versatile serial I/O port (SPI/QSPI/MICROWIRE/DSP Compatible).

SPI and QSPI are trademarks of Motorola, Inc.
 MICROWIRE is a trademark of National Semiconductor Corporation.

REV. C

Information furnished by Analog Devices is believed to be accurate and reliable. However, no responsibility is assumed by Analog Devices for its use, nor for any infringements of patents or other rights of third parties that may result from its use. No license is granted by implication or otherwise under any patent or patent rights of Analog Devices.

One Technology Way, P.O. Box 9106, Norwood, MA 02062-9106, U.S.A.
Tel: 781/329-4700
Fax: 781/326-8703
www.analog.com

AD7888—SPECIFICATIONS

($V_{DD} = 2.7\text{ V to }5.25\text{ V}$, $REFIN/REFOUT = 2.5\text{ V External/Internal Reference unless otherwise noted}$; $f_{SCLK} = 2\text{ MHz}$ ($V_{DD} = 2.7\text{ V to }5.25\text{ V}$); $T_A = T_{MIN}$ to T_{MAX} , unless otherwise noted.)

Parameter	A Version ¹	B Version ¹	Unit	Test Condition/Comment
DYNAMIC PERFORMANCE				
Signal to Noise + Distortion Ratio ^{2,3} (SNR)	71	71	dB typ	$f_{IN} = 10\text{ kHz Sine Wave}$, $f_{SAMPLE} = 125\text{ kSPS}$
Total Harmonic Distortion ² (THD)	-80	-80	dB typ	$f_{IN} = 10\text{ kHz Sine Wave}$, $f_{SAMPLE} = 125\text{ kSPS}$
Peak Harmonic or Spurious Noise ²	-80	-80	dB typ	$f_{IN} = 10\text{ kHz Sine Wave}$, $f_{SAMPLE} = 125\text{ kSPS}$
Intermodulation Distortion ² (IMD)				
Second Order Terms	-78	-78	dB typ	$f_a = 9.983\text{ kHz}$, $f_b = 10.05\text{ kHz}$, $f_{SAMPLE} = 125\text{ kSPS}$
Third Order Terms	-78	-78	dB typ	$f_a = 9.983\text{ kHz}$, $f_b = 10.05\text{ kHz}$, $f_{SAMPLE} = 125\text{ kSPS}$
Channel-to-Channel Isolation ²	-80	-80	dB typ	$f_{IN} = 25\text{ kHz}$
Full Power Bandwidth	2.5	2.5	MHz typ	@ 3 dB
DC ACCURACY				
Resolution	12	12	Bits	Any Channel
Integral Nonlinearity ²	± 2	± 1	LSB max	Guaranteed No Missed Codes to 11 Bits (A Grade)
Differential Nonlinearity ²	± 2	-1/+1.5	LSB max	Guaranteed No Missed Codes to 12 Bits (B Grade)
Offset Error	± 6	± 6	LSB max	$V_{DD} = 4.75\text{ V to }5.25\text{ V}$ (Typically $\pm 3\text{ LSB}$)
	± 4.5	± 4.5	LSB max	$V_{DD} = 2.7\text{ V to }3.6\text{ V}$ (Typically $\pm 2\text{ LSB}$)
Offset Error Match ²	2	2	LSB typ	
Gain Error ²	± 2	± 2	LSB max	Typically 30 LSB with Internal Reference
Gain Error Match ²	3	3	LSB max	
ANALOG INPUT				
Input Voltage Ranges	0 to V_{REF}	0 to V_{REF}	Volts	
Leakage Current	± 1	± 1	$\mu\text{A max}$	
Input Capacitance	38	38	pF typ	When in Track
	4	4	pF typ	When in Hold
REFERENCE INPUT/OUTPUT				
REFIN Input Voltage Range	$2.5/V_{DD}$	$2.5/V_{DD}$	V min/max	Functional from 1.2 V
Input Impedance	5	5	k Ω typ	Very High Impedance If Internal Reference Disabled
REFOUT Output Voltage	2.45/2.55	2.45/2.55	V min/max	
REFOUT Tempco	± 50	± 50	ppm/ $^{\circ}\text{C}$ typ	
LOGIC INPUTS				
Input High Voltage, V_{INH}	2.4	2.4	V min	$V_{DD} = 4.75\text{ V to }5.25\text{ V}$
	2.1	2.1	V min	$V_{DD} = 2.7\text{ V to }3.6\text{ V}$
Input Low Voltage, V_{INL}	0.8	0.8	V max	$V_{DD} = 2.7\text{ V to }5.25\text{ V}$
Input Current, I_{IN}	± 10	± 10	$\mu\text{A max}$	Typically 10 nA, $V_{IN} = 0\text{ V or }V_{DD}$
Input Capacitance, C_{IN} ⁴	10	10	pF max	
LOGIC OUTPUTS				
Output High Voltage, V_{OH}	$V_{DD} - 0.5$	$V_{DD} - 0.5$	V min	$I_{SOURCE} = 200\ \mu\text{A}$
Output Low Voltage, V_{OL}	0.4	0.4	V max	$V_{DD} = 2.7\text{ V to }5.25\text{ V}$
Floating-State Leakage Current	± 10	± 10	$\mu\text{A max}$	$I_{SINK} = 200\ \mu\text{A}$
Floating-State Output Capacitance ⁵	10	10	pF max	
Output Coding	Straight (Natural) Binary			
CONVERSION RATE				
Throughput Time	16	16	SCLK Cycles	Conversion Time + Acquisition Time. 125 kSPS with 2 MHz Clock
Track/Hold Acquisition Time ²	1.5	1.5	SCLK Cycles	
Conversion Time	14.5	14.5	SCLK Cycles	7.25 μs (2 MHz Clock)

Parameter	A Version ¹	B Version ¹	Unit	Test Condition/Comment
POWER REQUIREMENTS				
V _{DD}	2.7/5.25	2.7/5.25	V min/max	
I _{DD}				
Normal Mode ⁵ (Static)	700	700	μA max	f _{SAMPLE} = 125 kSPS
Normal Mode (Operational)	700	700	μA typ	f _{SAMPLE} = 50 kSPS
Using Standby Mode	450	450	μA typ	f _{SAMPLE} = 10 kSPS
Using Shutdown Mode	80	80	μA typ	f _{SAMPLE} = 1 kSPS
Standby Mode ⁶	12	12	μA max	V _{DD} = 2.7 V to 5.25 V
Shutdown Mode ⁶	2	2	μA max	V _{DD} = 4.75 V to 5.25 V (0.5 μA typ)
Normal-Mode Power Dissipation	1	1	μA max	V _{DD} = 2.7 V to 3.6 V
Shutdown Power Dissipation	3.5	3.5	mW max	V _{DD} = 5 V
Standby Power Dissipation	2.1	2.1	mW max	V _{DD} = 3 V
Shutdown Power Dissipation	10	10	μW max	V _{DD} = 5 V
Standby Power Dissipation	3	3	μW max	V _{DD} = 3 V
Shutdown Power Dissipation	1	1	mW max	V _{DD} = 5 V
Standby Power Dissipation	600	600	μW max	V _{DD} = 3 V

NOTES

¹Temperature ranges as follows: A Version: -40°C to +105°C; B Version: -40°C to +105°C.

²See Terminology.

³SNR calculation includes distortion and noise components.

⁴Sample tested @ 25°C to ensure compliance.

⁵All digital inputs @ GND except \overline{CS} @ V_{DD}. No load on the digital outputs. Analog inputs @ GND.

⁶SCLK @ GND when SCLK off. All digital inputs @ GND except for \overline{CS} @ V_{DD}. No load on the digital outputs. Analog inputs @ GND.

Specifications subject to change without notice.

ABSOLUTE MAXIMUM RATINGS¹

(T_A = 25°C unless otherwise noted)

V_{DD} to AGND -0.3 V to +7 V

Analog Input Voltage to AGND -0.3 V to V_{DD} + 0.3 V

Digital Input Voltage to AGND -0.3 V to V_{DD} + 0.3 V

Digital Output Voltage to AGND -0.3 V to V_{DD} + 0.3 V

REFIN/REFOUT to AGND -0.3 V to V_{DD} + 0.3 V

Input Current to Any Pin Except Supplies² ±10 mA

Operating Temperature Range

Commercial

(A Version) -40°C to +105°C

(B Version) °C to +105°C

Storage Temperature Range -65°C to +150°C

Junction Temperature 150°C

SOIC, TSSOP Package, Power Dissipation 450 mW

θ_{JA} Thermal Impedance 124.9°C/W (SOIC)

. 150.4°C/W (TSSOP)

θ_{JC} Thermal Impedance 42.9°C/W (SOIC)

. 27.6°C/W (TSSOP)

Lead Temperature, Soldering

Vapor Phase (60 secs) 215°C

Infrared (15 secs) 220°C

ESD 1 kV

NOTES

¹Stresses above those listed under Absolute Maximum Ratings may cause permanent damage to the device. This is a stress rating only; functional operation of the device at these or any other conditions above those listed in the operational sections of this specification is not implied. Exposure to absolute maximum rating conditions for extended periods may affect device reliability.

²Transient currents of up to 100 mA will not cause SCR latch-up.

CAUTION

ESD (electrostatic discharge) sensitive device. Electrostatic charges as high as 4000 V readily accumulate on the human body and test equipment and can discharge without detection. Although the AD7888 features proprietary ESD protection circuitry, permanent damage may occur on devices subjected to high-energy electrostatic discharges. Therefore, proper ESD precautions are recommended to avoid performance degradation or loss of functionality.



AD7888

TIMING SPECIFICATIONS¹ ($T_A = T_{MIN}$ to T_{MAX} , unless otherwise noted)

Parameter	Limit at T_{MIN} , T_{MAX} (A, B Versions)		Unit	Description
	4.75 V to 5.25 V	2.7 V to 3.6 V		
f_{SCLK}^2	2	2	MHz max	Throughput Time = $t_{CONVERT} + t_{ACQ} = 16 t_{SCLK}$ \overline{CS} to SCLK Setup Time Delay from \overline{CS} until DOUT 3-State Disabled Data Access Time after SCLK Falling Edge Data Setup Time Prior to SCLK Rising Edge Data Valid to SCLK Hold Time SCLK High Pulsewidth SCLK Low Pulsewidth \overline{CS} Rising Edge to DOUT High Impedance Power-Up Time from Shutdown
$t_{CONVERT}$	$14.5 t_{SCLK}$	$14.5 t_{SCLK}$		
t_{ACQ}	$1.5 t_{SCLK}$	$1.5 t_{SCLK}$		
t_1	10	10	ns min	
t_2^3	30	60	ns max	
t_3^3	75	100	ns max	
t_4	20	20	ns min	
t_5	20	20	ns min	
t_6	$0.4 t_{SCLK}$	$0.4 t_{SCLK}$	ns min	
t_7	$0.4 t_{SCLK}$	$0.4 t_{SCLK}$	ns min	
t_8^4	80	80	ns max	
t_9	5	5	μs typ	

NOTES

¹Sample tested at 25°C to ensure compliance. All input signals are specified with $t_r = t_f = 5$ ns (10% to 90% of V_{DD}) and timed from a voltage level of 1.6 V.

²Mark/Space ratio for the SCLK input is 40/60 to 60/40. See Serial Interface section.

³Measured with the load circuit of Figure 1 and defined as the time required for the output to cross 0.8 V or 2.4 V with $V_{DD} = 5$ V \pm 10% and time for an output to cross 0.4 V or 2.0 V with $V_{DD} = 3$ V \pm 10%.

⁴ t_8 is derived from the measured time taken by the data outputs to change 0.5 V when loaded with the circuit of Figure 1. The measured number is then extrapolated back to remove the effects of charging or discharging the 50 pF capacitor. This means that the time, t_8 , quoted in the timing characteristics is the true bus relinquish time of the part and is independent of the bus loading.

Specifications subject to change without notice.

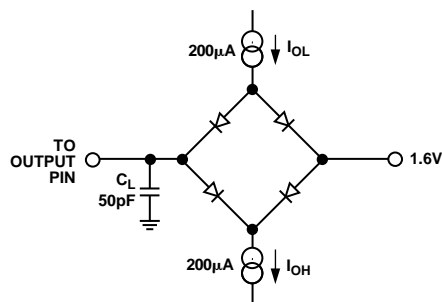
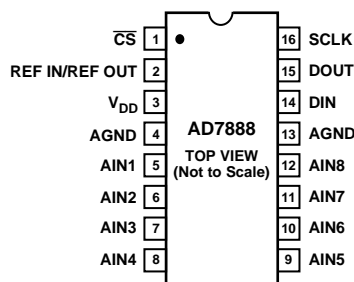

Figure 1. Load Circuit for Digital Output Timing Specifications

PIN CONFIGURATIONS SOIC AND TSSOP



PIN FUNCTION DESCRIPTIONS

Pin No.	Mnemonic	Function
1	$\overline{\text{CS}}$	Chip Select. Active low logic input. This input provides the dual function of initiating conversions on the AD7888 and also frames the serial data transfer.
2	REF IN/REF OUT	Reference Input/Output. The on-chip reference is available on this pin for use external to the AD7888. Alternatively, the internal reference can be disabled and an external reference applied to this input. The voltage range for the external reference is from 1.2 V to V_{DD} .
3	V_{DD}	Power Supply Input. The V_{DD} range for the AD7888 is from 2.7 V to 5.25 V.
4, 13	AGND	Analog Ground. Ground reference point for all circuitry on the AD7888. All analog input signals and any external reference signals should be referred to this AGND voltage. Both of these pins should connect to the AGND plane of a system.
5–12	AIN1–AIN8	Analog Input 1 through Analog Input 8. Eight single-ended analog input channels that are multiplexed into the on-chip track/hold. The analog input channel to be converted is selected by using the ADD0 through ADD2 bits of the Control Register. The input range for all input channels is 0 to V_{REF} . Any unused input channels should be connected to AGND to avoid noise pickup.
14	DIN	Data In. Logic Input. Data to be written to the AD7888's Control Register is provided on this input and is clocked into the register on the rising edge of SCLK (see Control Register section).
15	DOUT	Data Out. Logic Output. The conversion result from the AD7888 is provided on this output as a serial data stream. The bits are clocked out on the falling edge of the SCLK input. The data stream consists of four leading zeros followed by the 12 bits of conversion data, which is provided MSB first.
16	SCLK	Serial Clock. Logic Input. SCLK provides the serial clock for accessing data from the part and writing serial data to the Control Register. This clock input is also used as the clock source for the AD7888's conversion process.

AD7888

TERMINOLOGY

Integral Nonlinearity

This is the maximum deviation from a straight line passing through the endpoints of the ADC transfer function. The endpoints of the transfer function are zero scale, a point 1/2 LSB below the first code transition, and full scale, a point 1/2 LSB above the last code transition.

Differential Nonlinearity

This is the difference between the measured and the ideal 1 LSB change between any two adjacent codes in the ADC.

Offset Error

This is the deviation of the first code transition (00 . . . 000) to (00 . . . 001) from the ideal, i.e., AGND + 0.5 LSB.

Offset Error Match

This is the difference in offset error between any two channels.

Gain Error

This is the deviation of the last code transition (111 . . . 110) to (111 . . . 111) from the ideal (i.e., $V_{REF} - 1.5$ LSB) after the offset error has been adjusted out.

Gain Error Match

This is the difference in gain error between any two channels.

Track/Hold Acquisition Time

The track/hold amplifier returns into track mode at the end of conversion. Track/Hold acquisition time is the time required for the output of the track/hold amplifier to reach its final value, within $\pm 1/2$ LSB, after the end of conversion.

Signal to (Noise + Distortion) Ratio

This is the measured ratio of signal to (noise + distortion) at the output of the A/D converter. The signal is the rms amplitude of the fundamental. Noise is the sum of all nonfundamental signals up to half the sampling frequency ($f_s/2$), excluding dc. The ratio is dependent on the number of quantization levels in the digitization process; the more levels, the smaller the quantization noise. The theoretical signal to (noise + distortion) ratio for an ideal N-bit converter with a sine wave input is given by:

$$\text{Signal to (Noise + Distortion)} = (6.02N + 1.76) \text{ dB}$$

Thus for a 12-bit converter, this is 74 dB.

Total Harmonic Distortion

Total harmonic distortion (THD) is the ratio of the rms sum of harmonics to the fundamental. For the AD7888, it is defined as:

$$\text{THD (dB)} = \log \frac{\sqrt{V_2^2 + V_3^2 + V_4^2 + V_5^2 + V_6^2}}{V_1}$$

where V_1 is the rms amplitude of the fundamental and V_2, V_3, V_4, V_5 and V_6 are the rms amplitudes of the second through the sixth harmonics.

Peak Harmonic or Spurious Noise

Peak harmonic or spurious noise is defined as the ratio of the rms value of the next largest component in the ADC output spectrum (up to $f_s/2$ and excluding dc) to the rms value of the fundamental. Normally, the value of this specification is determined by the largest harmonic in the spectrum, but for ADCs where the harmonics are buried in the noise floor, it will be a noise peak.

Intermodulation Distortion

With inputs consisting of sine waves at two frequencies, f_a and f_b , any active device with nonlinearities will create distortion products at sum and difference frequencies of $m f_a \pm n f_b$ where $m, n = 0, 1, 2, 3$, etc. Intermodulation distortion terms are those for which neither m nor n is equal to zero. For example, the second order terms include $(f_a + f_b)$ and $(f_a - f_b)$, while the third order terms include $(2f_a + f_b)$, $(2f_a - f_b)$, $(f_a + 2f_b)$ and $(f_a - 2f_b)$.

The AD7888 is tested using the CCIF standard where two input frequencies near the top end of the input bandwidth are used. In this case, the second order terms are usually distanced in frequency from the original sine waves while the third order terms are usually at a frequency close to the input frequencies. As a result, the second and third order terms are specified separately. The calculation of the intermodulation distortion is as per the THD specification where it is the ratio of the rms sum of the individual distortion products to the rms amplitude of the sum of the fundamentals expressed in dBs.

Channel-to-Channel Isolation

Channel-to-channel isolation is a measure of the level of crosstalk between channels. It is measured by applying a full-scale 25 kHz sine wave signal to all nonselected input channels and determining how much that signal is attenuated in the selected channel. The figure given is the worst case across all four or eight channels for the AD7888.

PSR (Power Supply Rejection)

Variations in power supply will affect the full-scale transition, but not the converter's linearity. Power supply rejection is the maximum change in the full-scale transition point due to a change in power-supply voltage from the nominal value.

CONTROL REGISTER

The Control Register on the AD7888 is an 8-bit, write-only register. Data is loaded from the DIN pin of the AD7888 on the rising edge of SCLK. The data is transferred on the DIN line at the same time as the conversion result is read from the part. This requires 16 serial clocks for every data transfer. Only the information provided on the first 8 rising clock edges (after \overline{CS} falling edge) is loaded to the Control Register. MSB denotes the first bit in the data stream. The bit functions are outlined in Table I. The default contents of the Control Register on power-up is all zeros.

Table I. Control Register Bit Function Description

MSB

DONTC	ZERO	ADD2	ADD1	ADD0	REF	PM1	PM0
-------	------	------	------	------	-----	-----	-----

Bit	Mnemonic	Comment
7	DONTC	Don't Care. The value written to this bit of the Control Register is a don't care, i.e., it doesn't matter if the bit is 0 or 1.
6	ZERO	A zero must be written to this bit to ensure correct operation of the AD7888.
5	ADD2	These three address bits are loaded at the end of the present conversion sequence and select which analog input channel is converted for the next conversion. The selected input channel is decoded as shown in Table II.
4	ADD1	
3	ADD0	
2	REF	Reference Bit. With a 0 in this bit, the on-chip reference is enabled. With a 1 in this bit, the on-chip reference is disabled. To obtain best performance from the AD7888, the internal reference should be disabled when using an externally applied reference source. (See On-Chip Reference section.)
1, 0	PM1, PM0	Power Management Bits. These two bits decode the mode of operation of the AD7888 as shown in Table III.

PERFORMANCE CURVES

Figure 2 shows a typical FFT plot for the AD7888 at 100 kHz sample rate and 10 kHz input frequency.

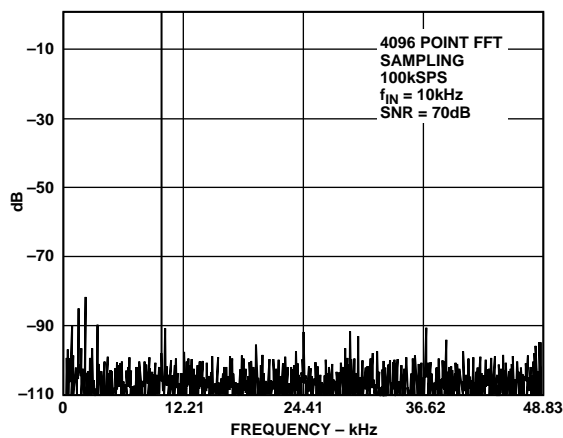

Figure 2. Dynamic Performance

Figure 3 shows a typical plot for the SNR vs. frequency for a 5 V supply and with a 5 V external reference.

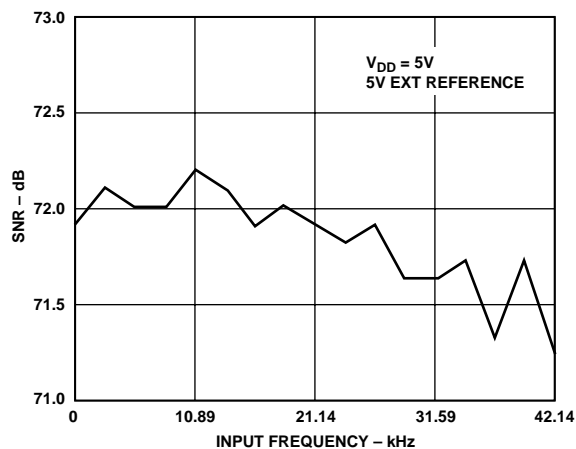

Figure 3. SNR vs. Input Frequency

AD7888

Figure 4 shows the typical power supply rejection ratio vs. frequency for the part. The power supply rejection ratio is defined as the ratio of the power in the ADC output at frequency f to the power of a full-scale sine wave applied to the ADC of frequency f_s :

$$PSRR (dB) = 10 \log (P_f/P_{f_s})$$

P_f = Power at frequency f in ADC output, P_{f_s} = power at frequency f_s in ADC full scale input. Here a 100 mV peak-to-peak sine wave is coupled onto the V_{DD} supply. Both the 2.7 V and 5.5 V supply performances are shown.

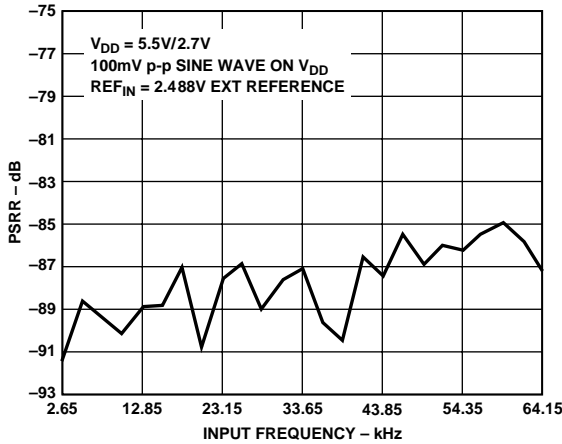

Figure 4. PSRR vs. Frequency

CIRCUIT INFORMATION

The AD7888 is a fast, low power, 12-bit, single supply, 8-channel A/D converter. The part can be operated from 3 V (2.7 V to 3.6 V) supply or from 5 V (4.75 V to 5.25 V) supply. When operated from either a 5 V supply or a 3 V supply, the AD7888 is capable of throughput rates of 125 kSPS when provided with a 2 MHz clock.

The AD7888 provides the user with an 8-channel multiplexer, on-chip track/hold, A/D converter, reference and serial interface housed in a tiny 16-lead TSSOP package, which offers the user considerable space saving advantages over alternative solutions. The serial clock input accesses data from the part and also provides the clock source for the successive-approximation A/D converter. The analog input range is 0 to V_{REF} (where the externally-applied V_{REF} can be between 1.2 V and V_{DD}).

The 8-channel multiplexer is controlled by the part's Control Register. This Control Register also allows the user to power-off the internal reference and to determine the Modes of Operation.

CONVERTER OPERATION

The AD7888 is a successive-approximation analog-to-digital converter based around a charge redistribution DAC. Figures 5 and 6 show simplified schematics of the ADC. Figure 5 shows the ADC during its acquisition phase. SW2 is closed and SW1 is in Position A, the comparator is held in a balanced condition and the sampling capacitor acquires the signal on AIN.

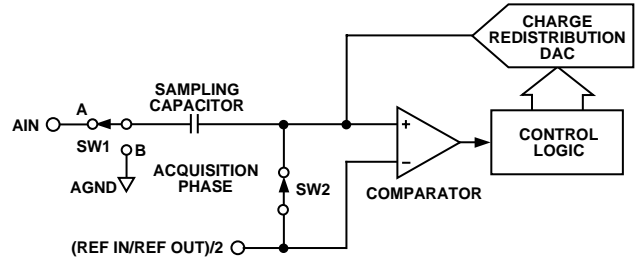

Figure 5. ADC Acquisition Phase

When the ADC starts a conversion, (see Figure 6), SW2 will open and SW1 will move to Position B causing the comparator to become unbalanced. The control logic and the charge redistribution DAC are used to add and subtract fixed amounts of charge from the sampling capacitor to bring the comparator back into a balanced condition. When the comparator is rebalanced, the conversion is complete. The control logic generates the ADC output code. Figure 7 shows the ADC transfer function.

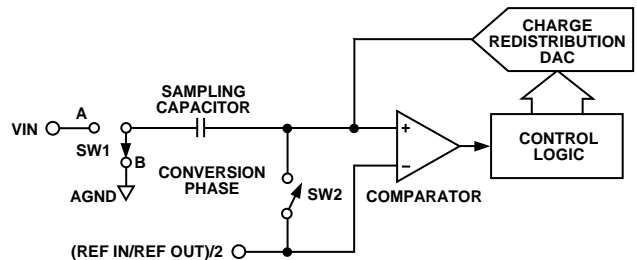

Figure 6. ADC Conversion Phase

ADC TRANSFER FUNCTION

The output coding of the AD7888 is straight binary. The designed code transitions occur at successive integer LSB values (i.e., 1 LSB, 2 LSBs, etc.). The LSB size is $= V_{REF}/4096$. The ideal transfer characteristic for the AD7888 is shown in Figure 7 below.

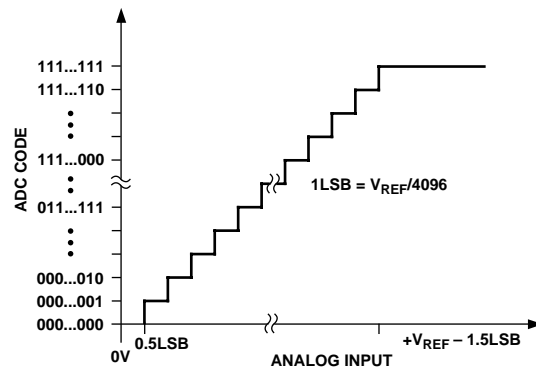

Figure 7. Transfer Characteristic

TYPICAL CONNECTION DIAGRAM

Figure 8 shows a typical connection diagram for the AD7888. Both AGND pins are connected to the analog ground plane of the system. V_{REF} is connected to a well decoupled V_{DD} pin to provide an analog input range of 0 V to V_{DD} . The conversion result is output in a 16-bit word with four leading zeroes followed by the MSB of the 12-bit result. For applications where power consumption is of concern, the automatic power down at the end of conversion should be used to improve power performance. See Modes of Operation section of the data sheet.

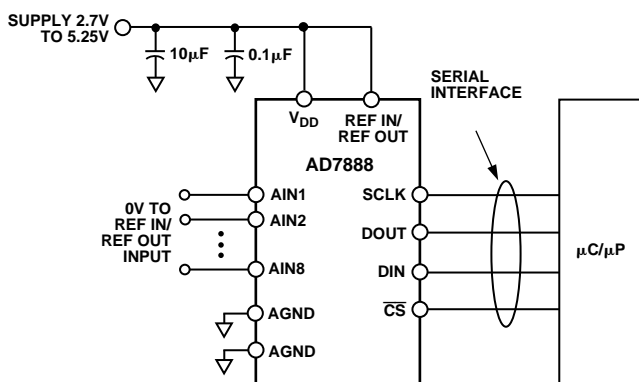

Figure 8. Typical Connection Diagram

Analog Input

Figure 9 shows an equivalent circuit of the analog input structure of the AD7888. The two diodes D1 and D2 provide ESD protection for the analog inputs. Care must be taken to ensure that the analog input signal never exceeds the supply rails by more than 200 mV. This will cause these diodes to become forward-biased and start conducting current into the substrate. 20 mA is the maximum current these diodes can conduct without causing irreversible damage to the part. However, it is worth noting that a small amount of current (1 mA) being conducted into the substrate due to an overvoltage on an unselected channel, can cause inaccurate conversions on a selected channel. The capacitor C1 in Figure 9 is typically about 4 pF and can primarily be attributed to pin capacitance. The resistor R1 is a lumped component made up of the on resistance of a multiplexer and a switch. This resistor is typically about 100 Ω . The capacitor C2 is the ADC sampling capacitor and has a capacitance of 20 pF typically.

Note: The analog input capacitance seen when the track and hold is in track mode is typically 38 pF, while in hold mode it is typically 4 pF.

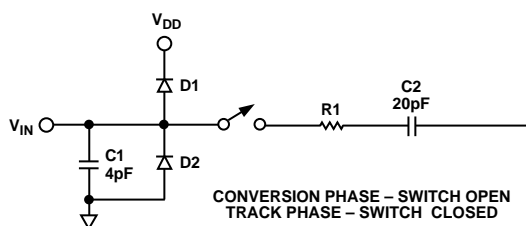

Figure 9. Equivalent Analog Input Circuit

For ac applications, removing high frequency components from the analog input signal is recommended by use of an RC low-pass filter on the relevant analog input pin. In applications where harmonic distortion and signal to noise ratio are critical the analog input should be driven from a low impedance source. Large source impedances will significantly affect the ac performance of the ADC. This may necessitate the use of an input buffer amplifier. The choice of the op amp will be a function of the particular application.

When no amplifier is used to drive the analog input the source impedance should be limited to low values. The maximum source impedance will depend on the amount of total harmonic distortion (THD) that can be tolerated. The THD will increase as the source impedance increases and performance will degrade. Figure 10 shows a graph of the total harmonic distortion versus analog input signal frequency for different source impedances.

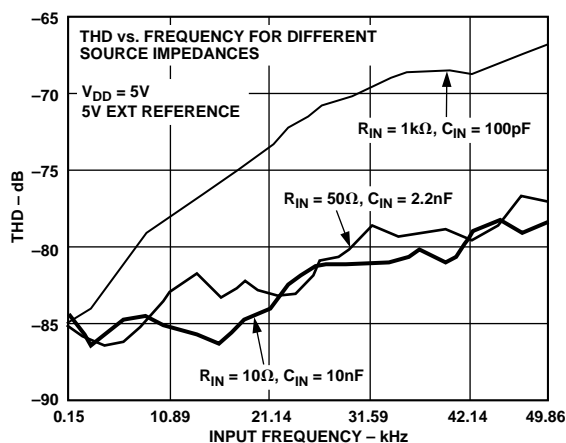

Figure 10. THD vs. Analog Input Frequency

Analog Input Selection

On power-up, the default AIN selection is AIN1. When returning to normal operation from power-down, the AIN selected will be the same one that was selected prior to power-down being initiated. Table II below shows the multiplexer address corresponding to each analog input from AIN1 to AIN8 for the AD7888.

Table II. Channel Configurations

ADD2	ADD1	ADD0	Analog Input Channel
0	0	0	AIN1
0	0	1	AIN2
0	1	0	AIN3
0	1	1	AIN4
1	0	0	AIN5
1	0	1	AIN6
1	1	0	AIN7
1	1	1	AIN8

On-Chip Reference

The AD7888 has an on-chip 2.5 V reference. This reference can be enabled or disabled by clearing or setting the REF bit in the Control Register, respectively. If the on-chip reference is to be used externally in a system, it must be buffered before it is applied elsewhere. If an external reference is applied to the device, the internal reference is automatically overdriven. However, in

AD7888

order to obtain optimum performance from the device it is advised to disable the internal reference by setting the REF bit in the Control Register when an external reference is applied. When the internal reference is disabled, SW1 in Figure 11 will open and the input impedance seen at the REF IN/REF OUT pin is the input impedance of the reference buffer, which is in the region of giga Ω . When the reference is enabled, the input impedance seen at the pin is typically 5 k Ω .

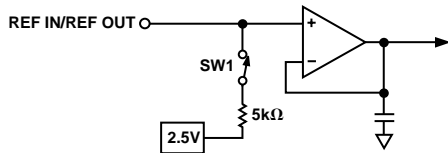

Figure 11. On-Chip Reference Circuitry

Table III. Power Management Options

PM1	PM0	Mode
0	0	Normal Operation. In this mode, the AD7888 remains in full power mode regardless of the status of any of the logic inputs. This mode allows the fastest possible throughput rate from the AD7888.
0	1	Full Shutdown. In this mode, the AD7888 is in full shutdown mode with all circuitry on the AD7888, including the on-chip reference, entering its power-down mode. The AD7888 retains the information in the control Register bits while in full shutdown. The part remains in full shutdown until these bits are changed.
1	0	Autoshutdown. In this mode, the AD7888 automatically enters full shutdown mode at the end of each conversion. Wake-up time from full shutdown is 5 μ s and the user should ensure that 5 μ s have elapsed before attempting to perform a valid conversion on the part in this mode.
1	1	Autostandby. In this standby mode, portions of the AD7888 are powered down but the on-chip reference voltage remains powered up. The REF bit should be 0 to ensure the on-chip reference is enabled. This mode is similar to auto-shutdown but allows the part to power-up much faster.

POWER-DOWN OPTIONS

The AD7888 provides flexible power management to allow the user to achieve the best power performance for a given throughput rate.

The power management options are selected by programming the power management bits (i.e., PM1 and PM0) in the control register. Table III summarizes the options available. When the power management bits are programmed for either of the auto power-down modes, the part will enter the power-down mode on the 16th rising SCLK edge after the falling edge of \overline{CS} . The first falling SCLK edge after the \overline{CS} falling edge will cause the part to power up again. When the AD7888 is in full shutdown,

the only way to fully power it up again is to reprogram the power management bits to PM1 = PM0 = 0, i.e., normal mode. In this case the device will power up on the 16th SCLK rising edge after the \overline{CS} falling edge as this is when the power management bits become effective.

Power-Up Times

The AD7888 has an approximate 1 μ s power-up time when powering up from standby or when using an external reference. When V_{DD} is first connected, the AD7888 will fully power up, i.e., it powers up in normal mode. If the part is put into shutdown, a subsequent power-up will take approximately 5 μ s. The AD7888 wake-up time is very short in the autostandby mode so it is possible to wake up the part and carry out a valid conversion in the same read/write operation.

POWER vs. THROUGHPUT RATE

By operating the AD7888 in autoshutdown or autostandby mode the average power consumption of the AD7888 decreases at lower throughput rates. Figure 12 shows how as the throughput rate is reduced, the device remains in its power-down state longer and the average power consumption over time drops accordingly.

For example, if the AD7888 were operated in a continuous sampling mode, with a throughput rate of 10 kSPS and a SCLK of 2 MHz ($V_{DD} = 5$ V), and if PM1 = 1 and PM0 = 0, i.e., the device is in autoshutdown mode and the on-chip reference is used, the power consumption is calculated as follows. The power dissipation during normal operation is 3.5 mW ($V_{DD} = 5$ V). If the power-up time is 5 μ s and the remaining conversion-plus-acquisition time is 15.5 t_{SCLK} , i.e., approximately 7.75 μ s, (see Figure 14a), the AD7888 can be said to dissipate 3.5 mW for 12.75 μ s during each conversion cycle. If the throughput rate is 10 kSPS, the cycle time is 100 μ s and the average power dissipated during each cycle is $(12.75/100) \times (3.5 \text{ mW}) = 446.25 \mu\text{W}$. If $V_{DD} = 3$ V SCLK = 2 MHz, and the device is again in autoshutdown mode using the on-chip reference, the power dissipation during normal operation is 2.1 mW. The AD7888 can now be said to dissipate 2.1 mW for 12.75 μ s during each conversion cycle. With a throughput rate of 10 kSPS, the average power dissipated during each cycle is $(12.75/100) \times (2.1 \text{ mW}) = 267.75 \mu\text{W}$. Figure 12 shows the power vs. throughput rate for automatic shutdown with both 5 V and 3 V supplies.

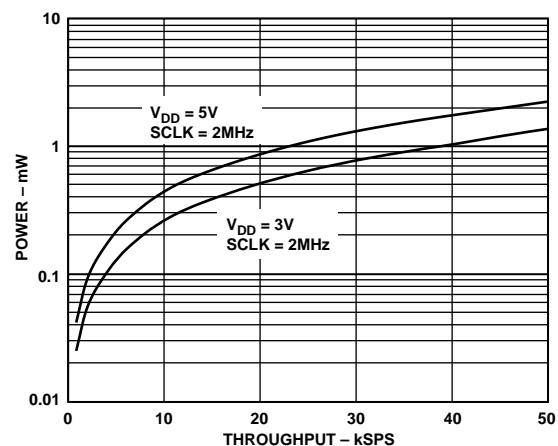

Figure 12. Power vs. Throughput

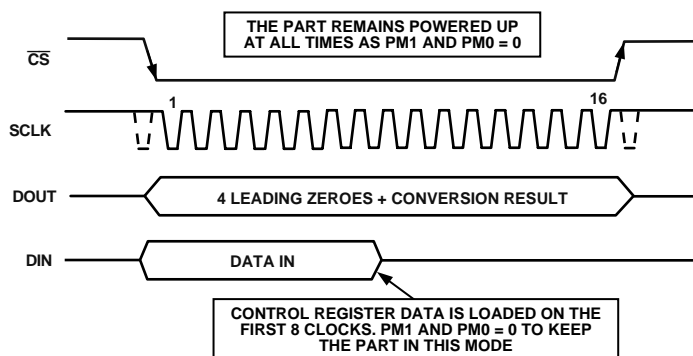

Figure 13. Normal-Mode Operation

MODES OF OPERATION

The AD7888 has a number of different modes of operation. These are designed to provide flexible power management options. These options can be chosen to optimize the power dissipation/throughput rate ratio for differing application requirements. The modes of operation are controlled by the PM1 and PM0 bits of the Control Register as outlined previously.

Normal Mode (PM1 = 0, PM0 = 0)

This mode is intended for fastest throughput rate performance as the user does not have to worry about any power-up times with the AD7888 remaining fully powered all the time. Figure 13 shows the general diagram of the operation of the AD7888 in this mode.

The data presented to the AD7888 on the DIN line during the first eight clock cycles of the data transfer are loaded to the Control Register. The part will remain powered up at the end of the conversion as long as PM1 and PM0 were set to zero in the write during that conversion. To continue to operate in this mode, the user must ensure that PM1 and PM0 are both loaded with 0 on every data transfer.

The falling edge of \overline{CS} initiates the sequence and the input signal is sampled on the second rising edge of the SCLK input. Sixteen serial clock cycles are required to complete the conversion and access the conversion result. Once a data transfer is complete (\overline{CS} has returned high), another conversion can be initiated immediately by bringing \overline{CS} low again.

Full Shutdown (PM1 = 0, PM0 = 1)

In this mode, all internal circuitry on the AD7888, including the on-chip reference, is powered-down. The part retains the information in the Control Register during full shutdown. The part remains in full shutdown until the power management bits are changed. If the power management bits are changed to PM1 = 1 and PM0 = 0, i.e., the autoshutdown mode, the part will remain in shutdown (now in autoshutdown) but will power up once a conversion is initiated after that (see Power-Up Times section). The part changes mode as soon as the control register has been updated, so if the part is in full shutdown mode and the power management bits are changed to PM1 = PM0 = 0, i.e., normal mode, then the part will power up on the 16th SCLK rising edge.

Autoshutdown (PM1 = 1, PM0 = 0)

In this mode, the AD7888 automatically enters its power-down mode at the end of every conversion. Figure 14a shows the general diagram of the operation of the AD7888 in this mode.

When \overline{CS} goes from high to low, all on-chip circuitry will start to power up on the next falling edge of SCLK. On the sixteenth SCLK rising edge the part will power down again. It takes approximately 5 μs for the AD7888 internal circuitry to be fully powered up. As a result, a conversion (or sample-and-hold acquisition) should not be initiated during this 5 μs . The input signal is sampled on the second rising edge of SCLK following the \overline{CS} falling edge. The user should ensure that 5 μs elapse between the first falling edge of SCLK after the falling edge of

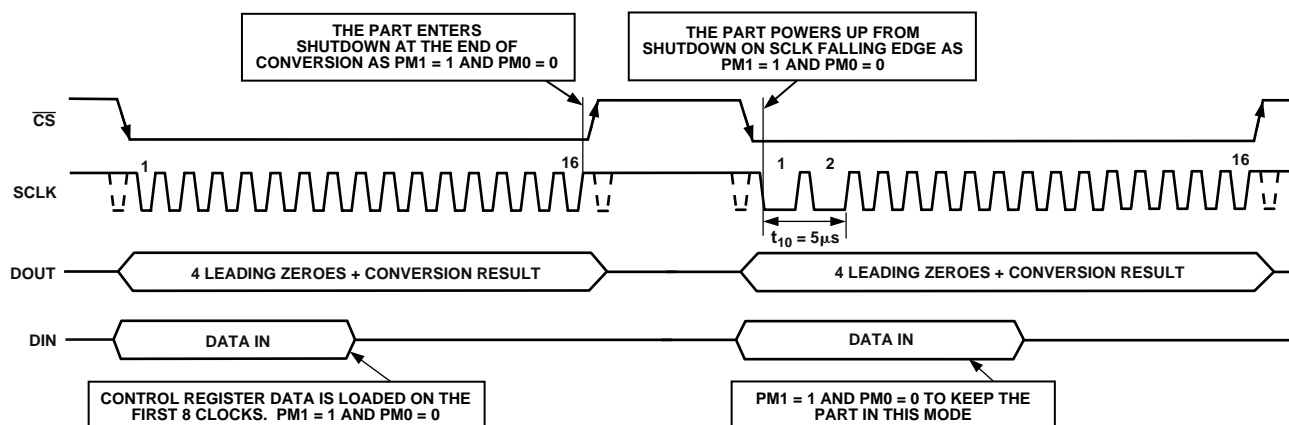

Figure 14a. Autos shutdown Operation

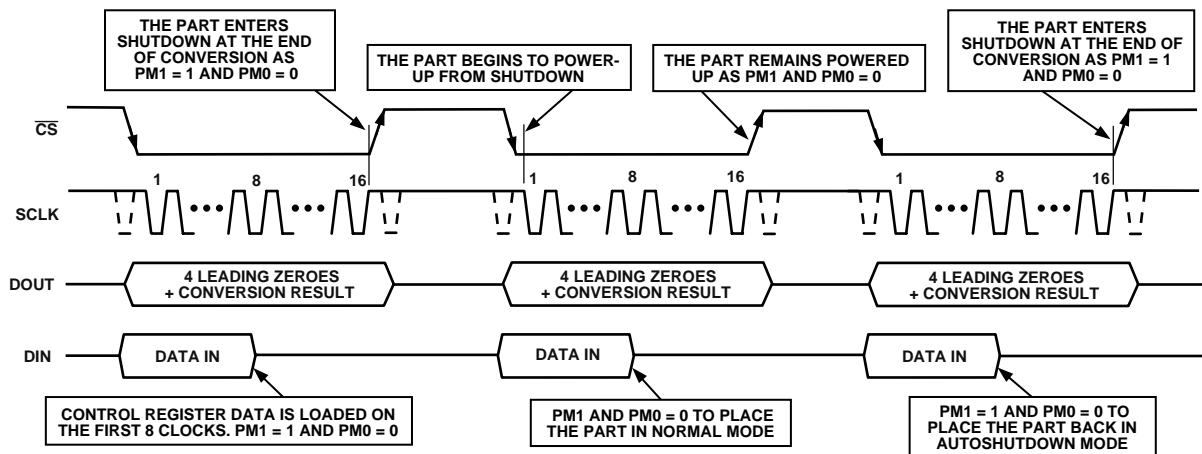

Figure 14b. Autoshutdown Operation

\overline{CS} and the second rising edge of SCLK as shown in Figure 14a. In microcontroller applications, this is readily achievable by driving the \overline{CS} input from one of the port lines and ensuring that the serial data read (from the microcontrollers serial port) is not initiated for 5 μ s. In DSP applications, where the \overline{CS} is generally derived from the serial frame synchronization line, it is not possible to separate the first falling edge and second rising edge of SCLK after the \overline{CS} falling edge by up to 5 μ s. Therefore, the user will need to write to the Control Register to exit this mode and (by writing PM1 = 0 and PM0 = 0) put the part into normal mode. A second conversion will then need to be initiated when the part is powered up to obtain a conversion result as shown in Figure 14b.

Autostandby (PM1 = 1, PM0 = 1)

In this mode, the AD7888 automatically enters a standby (or sleep) mode at the end of every conversion. In this standby mode, all on-chip circuitry, apart from the on-chip reference, is powered down. This mode is similar to the autoshutdown but in this case, the power-up time is much shorter as the on-chip reference remains powered up at all times.

Figure 15 shows the general diagram of the operation of the AD7888 in this mode. On the first falling SCLK edge after \overline{CS} goes low, the AD7888 comes out of standby. The AD7888 wake-up time is very short in this mode so it is possible to wake up the part and carry out a valid conversion in the same read/write operation. The input signal is sampled on the second rising edge of SCLK following the \overline{CS} falling edge. At the end of conversion (last rising edge of SCLK) the part automatically enters its standby mode.

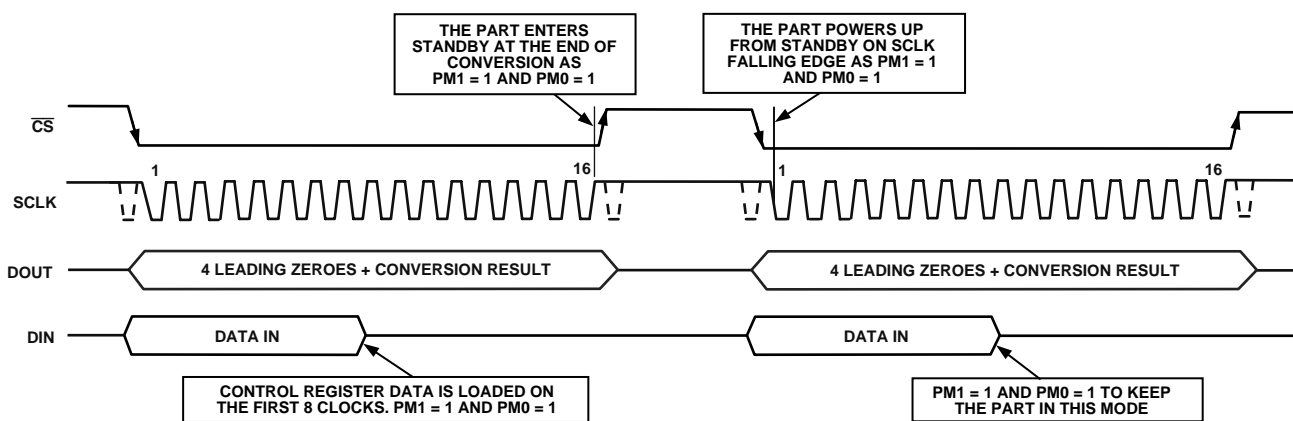

Figure 15. Autostandby Operation

SERIAL INTERFACE

Figure 16 shows the detailed timing diagram for serial interfacing to the AD7888. The serial clock provides the conversion clock and also controls the transfer of information to and from the AD7888 during conversion.

\overline{CS} initiates the data transfer and conversion process. For the autoshtutdown mode, the first falling edge of SCLK after the falling edge of \overline{CS} wakes up the part. In all cases, it gates the serial clock to the AD7888 and puts the on-chip track/hold into track mode. The input signal is sampled on the second rising edge of the SCLK input after the falling edge of \overline{CS} . Thus, the first one and one-half clock cycles after the falling edge of \overline{CS} is when the acquisition of the input signal takes place. This time is denoted as the acquisition time (t_{ACQ}). In autoshtutdown mode, the acquisition time must allow for the wake-up time of 5 μ s. The on-chip track/hold goes from track mode to hold mode on the second rising edge of SCLK and a conversion is also initiated on this edge. The conversion process takes a further fourteen and one-half SCLK cycles to complete. The rising edge of \overline{CS} will put the bus back into three-state. If \overline{CS} is left low a new conversion will be initiated.

The input channel that is sampled is the one selected in the previous write to the Control Register. Thus, the user must write ahead of the channel for conversion. In other words, the user must write the channel address for the next conversion while the present conversion is in progress.

Writing of information to the Control Register takes place on the first eight rising edges of SCLK in a data transfer. The Control Register is always written to when a data transfer takes place. The user must be careful to always set up the correct information on the DIN line when reading data from the part.

Sixteen serial clock cycles are required to perform the conversion process and to access data from the AD7888. In applications where the first serial clock edge, following \overline{CS} going low, is a falling edge, this edge clocks out the first leading zero. Thus, the first rising clock edge on the SCLK clock has the first leading zero provided. In applications where the first serial clock edge, following \overline{CS} going low, is a rising edge, the first leading zero may not be set up in time for the processor to read it correctly. However, subsequent bits are clocked out on the falling edge of SCLK so they are provided to the processor on the following rising edge. Thus, the second leading zero is clocked out on the falling edge subsequent to the first rising edge. The final bit in the data transfer is valid on the 16th rising edge, having being clocked out on the previous falling edge.

NOTE: The mark space ratio for SCLK is specified for at least 40% high time (with corresponding 60% low time) or 40% low time (with corresponding 60% high time). As the SCLK frequency is reduced, the mark space ratio may vary provided the conversion time never exceeds 50 μ s—to avoid capacitive droop effects.

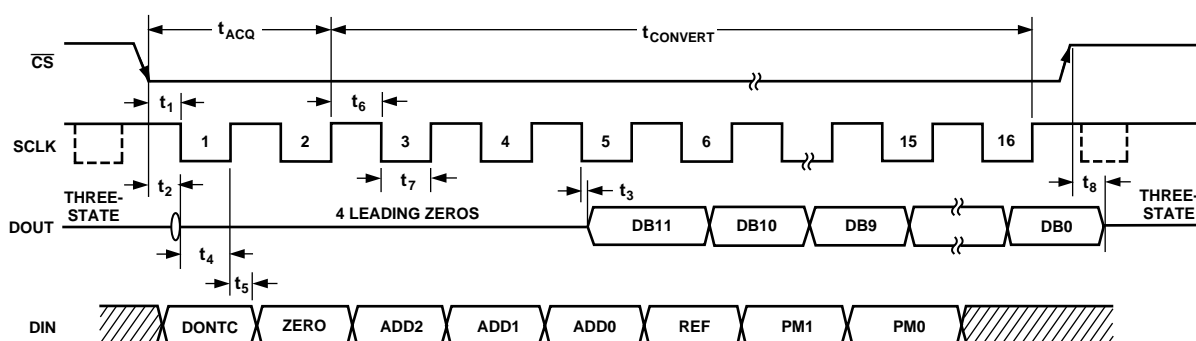

Figure 16. Serial Interface Timing Diagram

AD7888

MICROPROCESSOR INTERFACING

The serial interface on the AD7888 allows the part to be directly connected to a range of many different microprocessors. This section explains how to interface the AD7888 with some of the more common microcontroller and DSP serial interface protocols.

AD7888 to TMS320C5x

The serial interface on the TMS320C5x uses a continuous serial clock and frame synchronization signals to synchronize the data transfer operations with peripheral devices like the AD7888.

The \overline{CS} input allows easy interfacing with an inverter between the serial clock of the TMS320C5x and the AD7888 being the only glue logic required. The serial port of the TMS320C5x is set up to operate in burst mode with internal CLKX (TX serial clock) and FSX (TX frame sync). The serial port control register (SPC) must have the following setup: FO = 0, FSM = 1, MCM = 1 and TXM = 1. The connection diagram is shown in Figure 17.

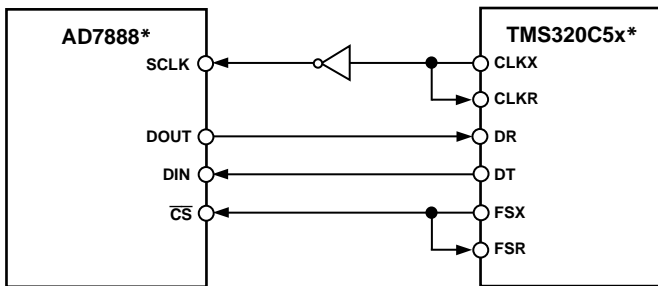

*ADDITIONAL PINS OMITTED FOR CLARITY

Figure 17. Interfacing to the TMS320C5x

AD7888 to ADSP-21xx

The ADSP-21xx family of DSPs are interfaced to the AD7888 with an inverter between the serial clock of the ADSP-21xx and the AD7888. This is the only glue logic required. The SPORT control register should be set up as follows:

TFSW = RFSW = 1, Alternate Framing
 INVRFS = INVTFSS = 1, Active Low Frame Signal
 DTYPE = 00, Right Justify Data
 SLEN = 1111, 16-Bit Data Words
 ISCLK = 1, Internal Serial Clock
 TFSR = RFSR = 1, Frame Every Word
 IRFS = 0
 ITFS = 1

The connection diagram is shown in Figure 18. The ADSP-21xx has the TFS and RFS of the SPORT tied together with TFS set as an output and RFS set as in input. The DSP operated in Alternate Framing Mode and the SPORT Control Register is set up as described. The frame synchronization signal generated on the TFS is tied to \overline{CS} and, as with all signal processing applications, equidistant sampling is necessary. However, in this example the timer interrupt is used to control the sampling rate of the ADC and, under certain conditions, equidistant sampling may not be achieved.

The Timer Registers, etc., are loaded with a value that will provide an interrupt at the required sample interval. When an interrupt is received, a value is transmitted with TFS/DT (ADC control word). The TFS is used to control the RFS and hence the reading of data. The frequency of the serial clock is set in the SCLKDIV Register. When the instruction to transmit with TFS is given, (i.e., AX0 = TX0), the state of the SCLK is checked. The DSP will wait until the SCLK has gone high, low and high before transmission will start. If the timer and SCLK values are chosen such that the instruction to transmit occurs on or near the rising edge of SCLK, the data may be transmitted or it may wait until the next clock edge.

For example, the ADSP-2111 has a master clock frequency of 16 MHz. If the SCLKDIV Register is loaded with the value 3, a SCLK of 2 MHz is obtained, and eight master clock periods will elapse for every one SCLK period. If the timer registers are loaded with the value 803, then 100.5 SCLKs will occur between interrupts and subsequently between transmit instructions. The situation will result in nonequidistant sampling as the transmit instruction is occurring on a SCLK edge. If the number of SCLKs between interrupts is not a figure of N.5, equidistant sampling will be implemented by the DSP.

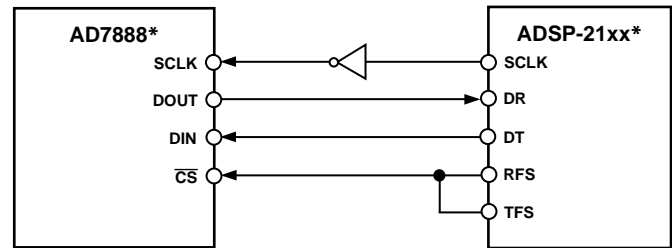

*ADDITIONAL PINS OMITTED FOR CLARITY

Figure 18. Interfacing to the ADSP-21xx

AD7888 to DSP56xxx

The connection diagram in Figure 19 shows how the AD7888 can be connected to the SSI (Synchronous Serial Interface) of the DSP56xxx family of DSPs from Motorola. The SSI is operated in synchronous mode (SYN bit in CRB = 1) with internally generated 1-bit clock period frame sync for both TX and RX (bits FSL1 = 1 and FSL0 = 0 in CRB). Set the word length to 16 by setting bits WL1 = 1 and WL0 = 0 in CRA. An inverter is also necessary between the SCLK from the DSP56xxx and the SCLK pin of the AD7888 as shown in Figure 19.

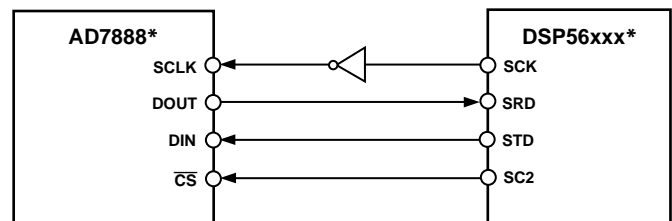

*ADDITIONAL PINS OMITTED FOR CLARITY

Figure 19. Interfacing to the DSP56xxx

AD7888 to MC68HC11

The Serial Peripheral Interface (SPI) on the MC68HC11 is configured for Master Mode (MSTR = 1), Clock Polarity Bit (CPOL) = 1 and the Clock Phase Bit (CPHA) = 1. The SPI is configured by writing to the SPI Control Register (SPCR)—see *68HC11 User Manual*. The serial transfer will take place as two 8-bit operations. A connection diagram is shown in Figure 20.

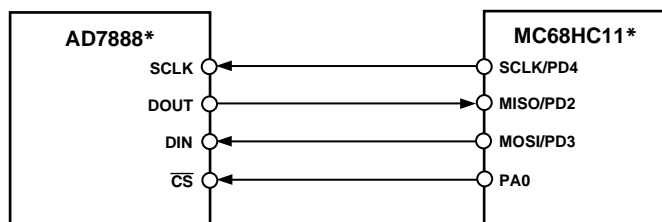

*ADDITIONAL PINS OMITTED FOR CLARITY

Figure 20. Interfacing to the MC68HC11

AD7888 to 8051

It is possible to implement a serial interface using the data ports on the 8051. This allows a full duplex serial transfer to be implemented. The technique involves “bit-banging” an I/O port (e.g., P1.0) to generate a serial clock and using two other I/O ports (e.g., P1.1 and P1.2) to shift data in and out—see Figure 21.

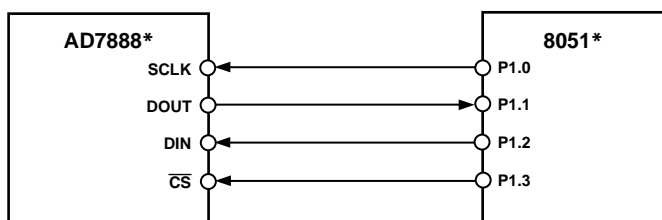

*ADDITIONAL PINS OMITTED FOR CLARITY

Figure 21. Interfacing to the 8051 Using I/O Ports

AD7888 to PIC16C6x/7x

The PIC16C6x Synchronous Serial Port (SSP) is configured as an SPI Master with the Clock Polarity Bit = 1. This is done by writing to the Synchronous Serial Port Control Register (SSPCON). See user PIC16/17 Microcontroller User Manual. Figure 22 shows the hardware connections needed to interface to the PIC16/17. In this example I/O port RA1 is being used to pulse \overline{CS} . This microcontroller only transfers eight bits of data during each serial transfer operation. Therefore, two consecutive read/write operations are needed.

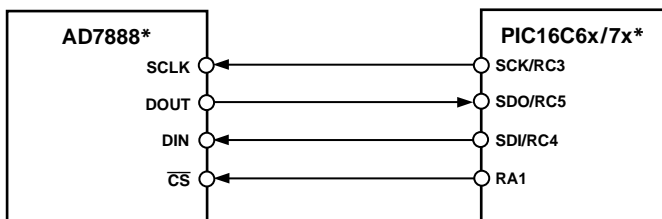

*ADDITIONAL PINS OMITTED FOR CLARITY

Figure 22. Interfacing to the PIC16C6x/7x

APPLICATION HINTS**Grounding and Layout**

The AD7888 has very good immunity to noise on the power supplies as can be seen by the PSRR vs. Frequency graph. However, care should still be taken with regard to grounding and layout.

The printed circuit board that houses the AD7888 should be designed so the analog and digital sections are separated and confined to certain areas of the board. This facilitates the use of ground planes that can be easily separated. A minimum etch technique is generally best for ground planes as it gives the best shielding. Digital and analog ground planes should be joined in only one place. Both AGND pins of the AD7888 should be sunk in the AGND plane. The AGND plane and DGND plane connection should be made at one point only, a star ground point that should be established as close as possible to an AGND pin of the AD7888.

Avoid running digital lines under the device as these will couple noise onto the die. The analog ground plane should be allowed to run under the AD7888 to avoid noise coupling. The power supply lines to the AD7888 should use as large a trace as possible to provide low impedance paths and reduce the effects of glitches on the power supply line. Fast switching signals like clocks should be shielded with digital ground to avoid radiating noise to other sections of the board, and clock signals should never be run near the analog inputs. Avoid crossover of digital and analog signals. Traces on opposite sides of the board should run at right angles to each other. This will reduce the effects of feedthrough through the board. A microstrip technique is by far the best but is not always possible with a double-sided board. In this technique, the component side of the board is dedicated to ground planes while signals are placed on the solder side.

Good decoupling is also important. All analog supplies should be decoupled with 10 μ F tantalum in parallel with 0.1 μ F capacitors to AGND. To achieve the best from these decoupling components, they must be placed as close as possible to the device, ideally right up against the device.

Evaluating the AD7888 Performance

The recommended layout for the AD7888 is outlined in the evaluation board for the AD7888. The evaluation board package includes a fully assembled and tested evaluation board, documentation, and software for controlling the board from the PC via the EVAL-CONTROL BOARD. The EVAL-CONTROL BOARD can be used in conjunction with the AD7888 evaluation board, as well as many other Analog Devices evaluation boards ending in the CB designator, to demonstrate/evaluate the ac and dc performance of the AD7888.

The software allows the user to perform ac (fast Fourier transform) and dc (histogram of codes) tests on the AD7888.

OUTLINE DIMENSIONS

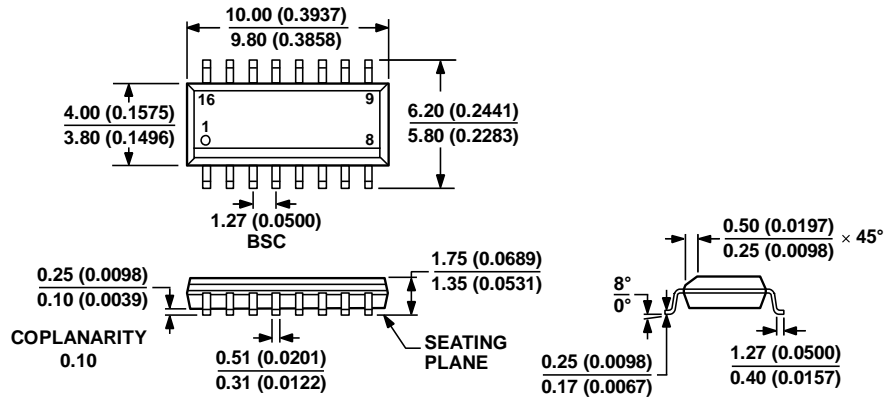

COMPLIANT TO JEDEC STANDARDS MS-012-AC
 CONTROLLING DIMENSIONS ARE IN MILLIMETERS; INCH DIMENSIONS
 (IN PARENTHESES) ARE ROUNDED-OFF MILLIMETER EQUIVALENTS FOR
 REFERENCE ONLY AND ARE NOT APPROPRIATE FOR USE IN DESIGN.

Figure 23. 16-Lead Standard Small Outline Package [SOIC_N]
 Narrow Body
 (R-16)

Dimensions shown in millimeters and (inches)

06060E-A

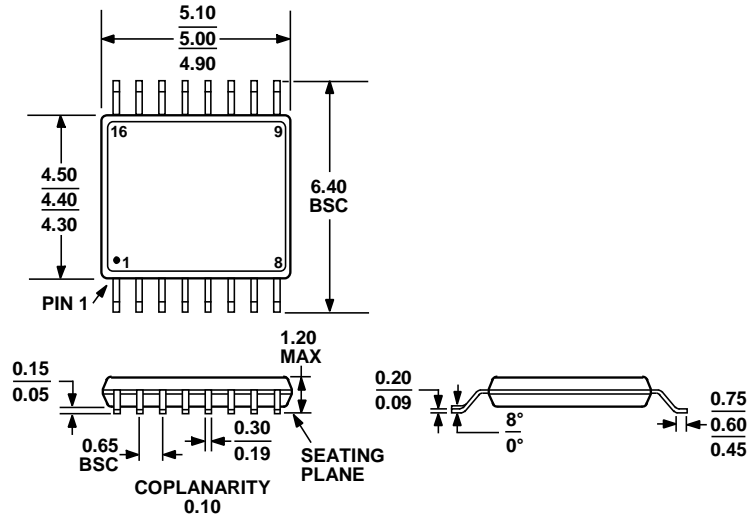

COMPLIANT TO JEDEC STANDARDS MO-153-AB

Figure 24. 16-Lead Thin Shrink Small Outline Package [TSSOP]
 (RU-16)

Dimensions shown in millimeters

ORDERING GUIDE

Model ¹	Notes	Linearity Error (LSB) ²	Temperature Range	Package Description	Package Option
AD7888ARU		±2	−40°C to +105°C	16-Lead Thin Shrink Small Outline Package [TSSOP]	RU-16
AD7888ARU-REEL		±2	−40°C to +105°C	16-Lead Thin Shrink Small Outline Package [TSSOP]	RU-16
AD7888ARU-REEL7		±2	−40°C to +105°C	16-Lead Thin Shrink Small Outline Package [TSSOP]	RU-16
AD7888ARUZ		±2	−40°C to +105°C	16-Lead Thin Shrink Small Outline Package [TSSOP]	RU-16
AD7888ARUZ-REEL		±2	−40°C to +105°C	16-Lead Thin Shrink Small Outline Package [TSSOP]	RU-16
AD7888ARUZ-REEL7		±2	−40°C to +105°C	16-Lead Thin Shrink Small Outline Package [TSSOP]	RU-16
AD7888ARZ		±2	−40°C to +105°C	16-Lead Standard Small Outline Package [SOIC_N]	R-16
AD7888ARZ-REEL		±2	−40°C to +105°C	16-Lead Standard Small Outline Package [SOIC_N]	R-16
AD7888ARZ-REEL7		±2	−40°C to +105°C	16-Lead Standard Small Outline Package [SOIC_N]	R-16
AD7888BR-REEL		±1	−40°C to +105°C	16-Lead Standard Small Outline Package [SOIC_N]	R-16
AD7888BR-REEL7		±1	−40°C to +105°C	16-Lead Standard Small Outline Package [SOIC_N]	R-16
AD7888BRZ		±1	−40°C to +105°C	16-Lead Standard Small Outline Package [SOIC_N]	R-16
EVAL-AD7888CB	³				

¹ Z = RoHS Compliant Part.

² Linearity error here refers to integral linearity error.

³ This can be used as a standalone evaluation board or in conjunction with the EVAL-CONTROL BOARD for evaluation/demonstration purposes.

REVISION HISTORY

6/10—Rev. B to Rev. C

Changes to Standby Mode Parameter, AD7888 Specifications Section	3
Changes to Operating Temperature Range, Commercial (B Version) Parameter, Absolute Maximum Ratings Section.....	3
Updated Outline Dimensions	16
Changes to Ordering Guide	17

6/01—Rev. A to Rev. B

Edit to DC Accuracy Section of Specifications	2
---	---

Looking for pricing, stock, or lifecycle information?

Click below to explore more details on WIN SOURCE:

- ⊖ [View AD7888ARUZ-REEL on WIN SOURCE](#)
- ⊖ [Analog Devices Inc. Information](#)

Optimize Your Supply Chain with WIN SOURCE Solutions

- ✓ Global Sourcing Solution
- ✓ Obsolete Management
- ✓ Cost Control Management
- ✓ Shortage Management
- ✓ Alternative Solution
- ✓ Excess Inventory Management