



**THE DATASHEET OF  
SL23EP08SC-2T**



**Low Jitter and Skew 10 to 220 MHz Zero Delay Buffer (ZDB)**

**Key Features**

- 10 to 220 MHz operating frequency range
- Low output clock skew: 45ps-typ
- Low output clock jitter:
  - 25 ps-typ cycle-to-cycle jitter
  - 15 ps-typ period jitter
- Low part-to-part output skew: 90 ps-typ
- Wide 2.5 V to 3.3 V power supply range
- Low power dissipation:
  - 20 mA-max at 66 MHz and VDD=3.3 V
  - 18 mA-max at 66 MHz and VDD=2.5V
- One input drives 8 outputs
- Multiple configurations and drive options
- Select mode to bypass PLL or tri-state outputs
- SpreadThru™ PLL that allows use of SSCG
- Available in 16-pin SOIC and TSSOP packages
- Available in Commercial and Industrial grades

**Applications**

- Printers, MFPs and Digital Copiers
- PCs and Work Stations
- Routers, Switchers and Servers
- Datacom and Telecom
- High-SpeedDigital Embedded Systems

**Description**

The SL23EP08 is a low skew, low jitter and low power Zero Delay Buffer (ZDB) designed to produce up to nine (9) clock outputs from one (1) reference input clock, for high speed clock distribution applications.

The product has an on-chip PLL and a feedback pin (FBK) which can be used to obtain feedback from any one of the output clocks. The SL23EP08 has two (2) clock driver banks each with four (4) clock outputs. These outputs are controlled by two (2) select input pins S1 and S2. When only four (4) outputs are needed, four (4) bank-B output clock buffers can be tri-stated to reduce power dissipation and jitter. The select inputs can also be used to tri-state both banks A and B or drive them directly from the input bypassing the PLL and making the product behave like a Non-Zero Delay Buffer (NZDB). The product also offers various 1X, 2X and 4X frequency options at the output clocks. Refer to the “Product Configuration Table” for the details.

The high-drive version operates up to 220MHz and 200MHz at 3.3V and 2.5V power supplies respectively.

**Benefits**

- Up to eight (8) distribution of input clock
- Standard and High-Dirive levels to control impedance level, frequency range and EMI
- Low power dissipation, jitter and skew
- Low cost

**Block Diagram**

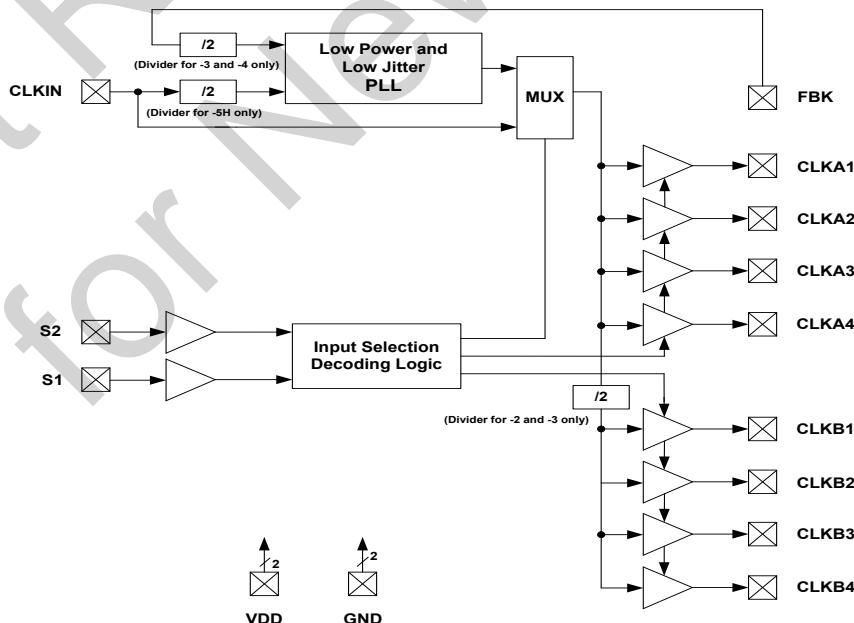

**16-Pin SOIC and TSSOP**

**Pin Configuration**

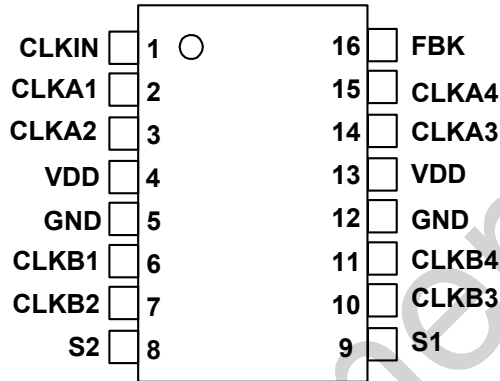

**Pin Description**

Pin Number	Pin Name	Pin Type	Pin Description
1	CLKIN	Input	Reference Frequency Clock Input. 5V tolerant input. Weak pull-down (250kΩ).
2	CLKA1	Output	Buffered Clock Output, Bank A. Weak pull-down (250kΩ).
3	CLKA2	Output	Buffered Clock Output, Bank A. Weak pull-down (250kΩ).
4	VDD	Power	3.3V or 2.5V Power Supply.
5	GND	Power	Power Ground.
6	CLKB1	Output	Buffered Clock Output, Bank B. Weak pull-down (250kΩ).
7	CLKB2	Output	Buffered Clock Output, Bank B. Weak pull-down (250kΩ).
8	S2	Input	Select Input, select pin S2. Weak pull-up (250kΩ).
9	S1	Input	Select Input, select pin S1. Weak pull-up (250kΩ).
10	CLKB3	Output	Buffered Clock Output, Bank B. Weak pull-down (250kΩ).
11	CLKB4	Output	Buffered Clock Output, Bank B. Weak pull-down (250kΩ).
12	GND	Power	Power Ground.
13	VDD	Power	3.3V or 2.5V Power Supply.
14	CLKA3	Output	Buffered Clock Output, Bank A. Weak pull-down (250kΩ).
15	CLKA4	Output	Buffered Clock Output, Bank A. Weak pull-down (250kΩ).
16	FBK	Output	PLL Feedback input.

**General Description-**

The SL23EP08 is a low skew, low jitter Zero Delay Buffer with very low operating current.

The product includes an on-chip high performance PLL that locks into the input reference clock and produces nine (9) output clock drivers tracking the input reference clock for systems requiring clock distribution.

In addition to CLKOUT that is used for internal PLL feedback, there are two (2) banks with four (4) outputs in each bank, bringing the number of total available output clocks to nine (9).

**Input and output Frequency Range-**

The input and output frequency range is the same. But, the frequency range depends on VDD and drive levels as given in the below Table 1.

VDD(V)	Drive	Min(MHz)	Max(MHz)
3.3	HIGH	10	220
3.3	STD	10	167
2.5	HIGH	10	200
2.5	STD	10	133

**Table 1. Input/Output Frequency Range**

If the input clock frequency is less than 2 MHz or floating, this is detected by an input frequency detection circuitry and all eight (8) clock outputs are forced to Hi-Z. The PLL is shutdown to save power. In this shutdown state, the product draws less than 25  $\mu$ A supply current.

**SpreadThru™ Feature-**

If a Spread Spectrum Clock (SSC) were to be used as an input clock, the SL23EP08 is designed to pass the modulated Spread Spectrum Clock (SSC) signal from its reference input to the output clocks. The same spread characteristics at the input are passed through the PLL and drivers without any degradation in spread percent (%), spread profile and modulation frequency

**Select Input Control-**

The SL23EP08 provides two (2) input select control pins called S1 and S2. This feature enables users to select various states of output clock banks-A and bank-B, output source and PLL shutdown features as shown in the Table 2.

The S1 (Pin-9) and S2 (Pin-8) inputs include 250 k $\Omega$  weak pull-down resistors to GND.

**PLL Bypass Mode**

If the S1 and S2 pins are logic Low(0) and High(1) respectively, the on-chip PLL is shutdown and bypassed, and all the nine output clocks bank A, bank B and CLKOUT clocks are driven by directly from the reference input clock. In this operation mode SL23EP08 works like a non-ZDB product.

**High and Low-Drive Product Options -**

The SL23EP08 is offered with High-Drive “-1H” and Standard-Drive “-1” options. These drive options enable the users to control load levels, frequency range and EMI control. Refer to the AC electrical tables for the details.

**Skew and Zero Delay -**

All outputs should drive the similar load to achieve output-to-output skew and input-to-output specifications given in the AC electrical tables. However, Zero delay between input and outputs can be adjusted by changing the loading of CLKOUT relative to the banks A and B clocks since CLKOUT is the feedback to the PLL.

**Power Supply Range (VDD)-**

The SL23EP08 is designed to operate in a wide power supply range from 2.3V (Min) to 3.3V (Max). An internal on-chip voltage regulator is used to supply PLL constant power supply of 1.8V, leading to a consistent and stable PLL electrical performance in terms of skew, jitter and power dissipation. Contact SLI for 1.8V power supply version ZDB called SL23EPL08.

S2	S1	Clock A1-A4	Clock B1-B4	CLKOUT	Output Source	PLL Shutdown and Bypass
0	0	Tri-state	Tri-state	Driven	PLL	Yes
0	1	Driven	Tri-state	Driven	PLL	No
1	0	Driven <sup>[1]</sup>	Driven <sup>[1]</sup>	Driven (4)	Reference	Yes
1	1	Driven	Driven	Driven	PLL	No

**Table 2. Select Input Decoding**

Device	Feedback From	Bank-A Frequency	Bank-B Frequency
SL23EP08-1	Bank-A or Bank-B	Reference	Reference
SL23EP08-1H	Bank-A or Bank-B	Reference	Reference
SL23EP08-2	Bank-A	Reference	Reference/2
SL23EP08-2	Bank-B	2x Reference	Reference
SL23EP08-3	Bank-A	2X Reference	Reference <sup>[2]</sup>
SL23EP08-3	Bank-B	4X Reference	2X Reference
SL23EP08-4	Bank-A or Bank-B	2X Reference	2X Reference
SL23EP08-5H	Bank-A or Bank-B	Reference /2	Reference /2

**Table 3. Available SL23EP08 Configurations**

Notes:

1. Outputs are inverted on SL23EP08-2 and SL23EP08-3 in PLL bypass mode when S2=1 and S1=0.
2. Output phase is either 0° or 180° with respect to CLKIN input. If phase integrity is required, use the SL23EP08-2.

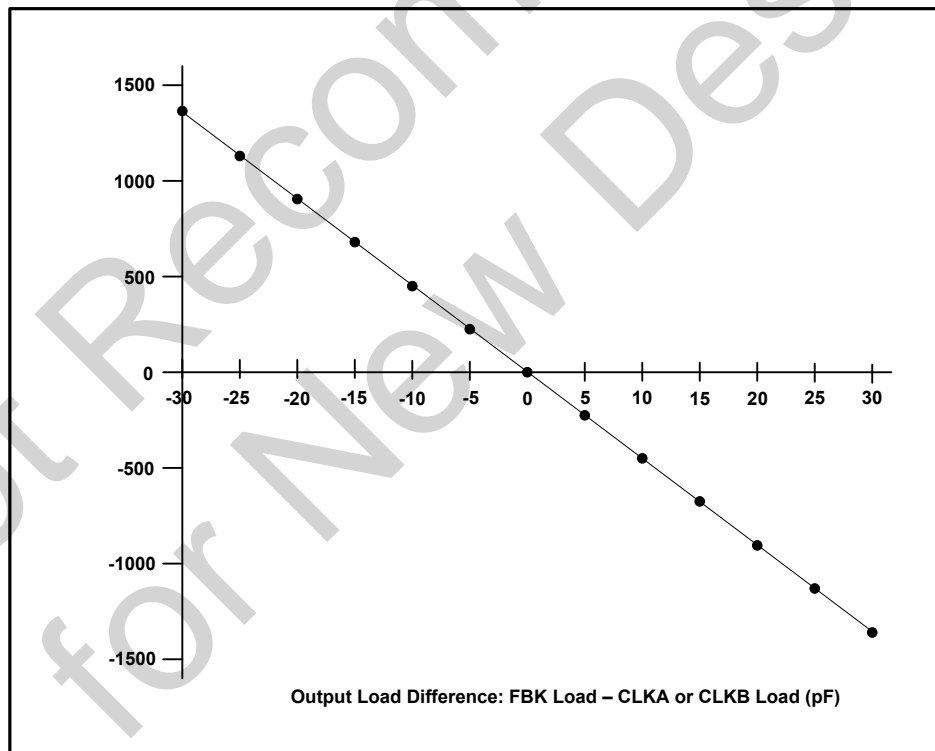

**Figure 1. CLKIN Input to CLKA and CLKB Delay**

**Absolute Maximum Ratings**

Description	Condition	Min.	Max.	Unit
Supply voltage, VDD		-0.5	4.6	V

All Inputs and Outputs		- 0.5	VDD+0.5	V
Ambient Operating Temperature	In operation, C-Grade	0	70	°C
Ambient Operating Temperature	In operation, I-Grade	- 40	85	°C
Storage Temperature	No power is applied	- 65	150	°C
Junction Temperature	In operation, power is applied	-	125	°C
Soldering Temperature		-	260	°C
ESD Rating (Human Body Model)	MIL-STD-883, Method 3015	2000	-	V

**Operating Conditions: Unless otherwise stated VDD=2.5V to 3.3V and for both C and I Grades**

Symbol	Description	Condition	Min.	Max.	Unit
VDD3.3	3.3V Supply Voltage	3.3V+/-10%	3.0	3.6	V
VDD2.5	2.5V Supply Voltage	2.5V+/-10%	2.3	2.7	V
TA	Operating Temperature(Ambient)	Commercial	0	70	°C
		Industrial	-40	85	°C
CLOAD	Load Capacitance	<100 MHz, 3.3V with Standard or High drive	-	30	pF
		<100 MHz, 2.5V with High drive	-	30	pF
		<133.3 MHz, 3.3V with Standard or High drive	-	22	pF
		<133.3 MHz, 2.5V with High drive	-	22	pF
		<133.3 MHz, 2.5V with Standard drive	-	15	pF
		>133.3 MHz, 3.3V with Standard or High drive	-	15	pF
		>133.3 MHz, 2.5V with High drive	-	15	pF
CIN	Input Capacitance	S1, S2 and CLKIN pins	-	5	pF
CLBW	Closed-loop bandwidth	3.3V, (typical)		1.2	MHz
		2.5V, (typical)		0.8	MHz
ZOUT	Output Impedance	3.3V, (typical), High drive		29	Ω
		3.3V, (typical), Standard drive		41	Ω
		2.5V, (typical), High drive		37	Ω
		2.5V, (typical), Standard drive		41	Ω

**DC Electrical Specifications (VDD=3.3V): Unless otherwise stated for both C and I Grades**

Symbol	Description	Condition	Min.	Max.	Unit
--------	-------------	-----------	------	------	------

VDD	Supply Voltage		2.970	3.630	V
VIL	Input LOW Voltage		–	0.8	V
VIH	Input HIGH Voltage		2.0	V <sub>DD</sub> +0.3	V
IIL	Input Leakage Current	0 < VIN < 0.8V	–	±10	µA
IIH	Input HIGH Current	VIN = VDD	–	100	µA
VOL	Output LOW Voltage	IOL = 8 mA (standard drive)	–	0.4	V
		IOL = 12 mA (high drive)	–	0.4	V
VOH	Output HIGH Voltage	IOH = –8 mA (standard drive)	2.4	–	V
		IOH = –12 mA (high drive)	2.4	–	V
IDDPD	Power Down Supply Current CLKIN<2MHz	CLKIN = 0 MHz (C-Grade)	–	12	µA
		CLKIN = 0 MHz (I-Grade)	–	25	µA
IDD	Power Supply Current	All Outputs CL=0, 66-MHz CLKIN	–	20	mA

**DC Electrical Specifications (VDD=2.5V): Unless otherwise stated for both C and I Grades**

Symbol	Description	Condition	Min.	Max.	Unit.
VDD	Supply Voltage		2.3	2.7	V
VIL	Input LOW Voltage		–	0.7	V
VIH	Input HIGH Voltage		1.7	V <sub>DD</sub> + 0.3	V
IIL	Input Leakage Current	0<VIN < 0.8V	–	10	µA
IIH	Input HIGH Current	VIN = VDD	–	100	µA
VOL	Output LOW Voltage	IOL = 8 mA (standard drive)	–	0.5	V
		IOL = 12 mA (high drive)	–	0.5	V
VOH	Output HIGH Voltage	IOH = –8 mA (standard drive)	V <sub>DD</sub> – 0.6	–	V
		IOH = –12 mA (high drive)	V <sub>DD</sub> – 0.6	–	V
IDDPD	Power Down Supply Current CLKIN<2MHz	CLKIN = 0 MHz (C-Grade)	–	12	µA
		CLKIN = 0 MHz (I-Grade)	–	25	µA
IDD	Power Supply Current	All Outputs CL=0, 66-MHz CLKIN	–	18	mA

**AC Electrical Specifications: VDD=3.3V+/-10% and 0°C to +70°C Operation (Commercial Grade)**

Symbol	Description	Condition	Min	Typ	Max	Unit
FOUT-1	Output Frequency	CL=30pf, All devices	10	-	160	MHz
FOUT-2	Output Frequency	CL=20pF, -1H and -5H versions	10	-	220	MHz
FOUT-2	Output Frequency	CL=15pF, -1,-2,-3 and -4 versions	10	-	200	MHz
DC-1	Duty Cycle. -1, -2, -3,-4,-1H and -5H versions	CL=30pF, FOUT=66.6MHz and Measured at VDD/2	40.0	50.0	60.0	%
DC-2	Duty Cycle. -1, -2, -3,-4,-1H and -5H versions	CL=15pF, FOUT<66.6MHz and Measured at VDD/2	45.0	50.0	55.0	%
DC-1	Duty Cycle. -1, -2, -3,-4,-1H and -5H versions	CL=30pF, FOUT=120MHz and Measured at VDD/2	TBD	TBD	TBD	%
DC-2	Duty Cycle. -1, -2, -3,-4,-1H and -5H versions	CL=15pF, FOUT=120MHz and Measured at VDD/2	TBD	TBD	TBD	%
tr/f-1	Rise and Fall Times. -1, -2, -3, and -4 versions	Measured between 0.8V and 2.0V CL=30pF	-	-	1.6	ns
tr/f-2	Rise and Fall Times. -1, -2, -3, and -4 versions	Measured between 0.8V and 2.0V CL=15pF	-	-	1.2	ns
tr/f-3	Rise and Fall Times. -1,1H and -5H versions	Measured between 0.8V and 2.0V CL=30pF	-	-	1.2	ns
tr/f-3	Rise and Fall Times. -1H and -5H versions	Measured between 0.8V and 2.0V CL=15pF	-	-	1.0	ns
SKW-1	Output-to-Output on same bank A or B. All versions	All outputs are equally loaded. Measured at VDD/2	-	60	150	ps
SKW-2	Output Bank-A to Bank-B Skew. -1-4 and -5H versions	All outputs are equally loaded. Measured at VDD/2	-	60	150	ps
SKW-3	Output Bank-A to Bank-B Skew. -1-4 and -5H versions	All outputs are equally loaded. Measured at VDD/2	-	130	300	ps
SKW-4	Device-to-Device Skew. All versions	All outputs are equally loaded. Measured at VDD/2 and FBK pin	-	180	500	ps
tCFD	CLKIN to FBK Rising Edge Delay	All outputs are equally loaded. Measured at VDD/2	-200	-	200	ps
t2	Delay Time, CLKIN Rising Edge to CLKOUT Rising Edge <sup>[2]</sup> (Measured at VDD/2)	PLL Bypass mode	1.5	-	4.4	ns
		PLL enabled @ 3.3V	-100	-	100	ps
		PLL enabled @2.5V	-200	-	200	ps
t3	Part-to-Part Skew <sup>[2]</sup> (Measured at VDD/2)	Measured at VDD/2. Any output to any output, 3.3V supply	-	-	±150	ps
		Measured at VDD/2. Any output to any output, 2.5V supply	-	-	±300	ps
tLOCK	PLL Lock Time	Valid on all clock pins from VDD=2.97V	-	-	1.0	ms

**AC Electrical Specifications: VDD=3.3V+/-10% and -40°C to +85°C Operation (Industrial Grade)**

Symbol	Description	Condition	Min	Typ	Max	Unit
FOUT-1	Output Frequency	CL=30pf, All devices	10	-	160	MHz
FOUT-2	Output Frequency	CL=20pF, -1H and -5H versions	10	-	220	MHz
FOUT-2	Output Frequency	CL=15pF, -1,-2,-3 and -4 versions	10	-	200	MHz
DC-1	Duty Cycle. -1, -2, -3,-4,-1H and -5H versions	CL=30pF, FOUT=66.6MHz and Measured at VD/2	40.0	50.0	60.0	%
DC-2	Duty Cycle. -1, -2, -3,-4,-1H and -5H versions	CL=15pF, FOUT<66.6MHz and Measured at VDD/2	45.0	50.0	55.0	%
DC-1	Duty Cycle. -1, -2, -3,-4,-1H and -5H versions	CL=30pF, FOUT=120MHz and Measured at VDD/2	TBD	TBD	TBD	%
DC-2	Duty Cycle. -1, -2, -3,-4,-1H and -5H versions	CL=15pF, FOUT=120MHz and Measured at VDD/2	TBD	TBD	TBD	%
tr/f-1	Rise and Fall Times. -1, -2, -3, and -4 versions	Measured between 0.8V and 2.0V CL=30pF	-	-	1.6	ns
tr/f-2	Rise and Fall Times. -1, -2, -3, and -4 versions	Measured between 0.8V and 2.0V CL=15pF	-	-	1.2	ns
tr/f-3	Rise and Fall Times. -1,1H and -5H versions	Measured between 0.8V and 2.0V CL=30pF	-	-	1.2	ns
tr/f-3	Rise and Fall Times. -1H and -5H versions	Measured between 0.8V and 2.0V CL=15pF	-	-	1.0	ns
SKW-1	Output-to-Output on same bank A or B. All versions	All outputs are equally loaded. Measured at VDD/2	-	60	150	ps
SKW-2	Output Bank-A to Bank-B Skew. -1-4 and -5H versions	All outputs are equally loaded. Measured at VDD/2	-	60	150	ps
SKW-3	Output Bank-A to Bank-B Skew. -1-4 and -5H versions	All outputs are equally loaded. Measured at VDD/2	-	130	300	ps
SKW-4	Device-to-Device Skew. All versions	All outputs are equally loaded. Measured at VDD/2 and FBK pin	-	180	500	ps
tCFD	CLKIN to FBK Rising Edge Delay	All outputs are equally loaded. Measured at VDD/2	-200	-	200	ps
t2	Delay Time, CLKIN Rising Edge to CLKOUT Rising Edge <sup>[2]</sup> (Measured at VDD/2)	PLL Bypass mode	1.5	-	4.4	ns
		PLL enabled @ 3.3V	-100	-	100	ps
		PLL enabled @2.5V	-200	-	200	ps
t3	Part-to-Part Skew <sup>[2]</sup> (Measured at VDD/2)	Measured at VDD/2. Any output to any output, 3.3V supply	-	-	±150	ps
		Measured at VDD/2. Any output to any output, 2.5V supply	-	-	±300	ps
tLOCK	PLL Lock Time	Valid on all clock pins from VDD=2.97V	-	-	1.0	ms

**AC Electrical Specifications: VDD=2.5V+/-10% and 0°C to +70°C Operation (Commercial Grade)**

Symbol	Description	Condition	Min	Typ	Max	Unit
FOUT-1	Output Frequency	CL=30pf, All devices	10	-	160	MHz
FOUT-2	Output Frequency	CL=20pF, -1H and -5H versions	10	-	220	MHz
FOUT-2	Output Frequency	CL=15pF, -1,-2,-3 and -4 versions	10	-	200	MHz
DC-1	Duty Cycle. -1, -2, -3,-4,-1H and -5H versions	CL=30pF, FOUT=66.6MHz and Measured at VDD/2	40.0	50.0	60.0	%
DC-2	Duty Cycle. -1, -2, -3,-4,-1H and -5H versions	CL=15pF, FOUT<66.6MHz and Measured at VDD/2	45.0	50.0	55.0	%
DC-1	Duty Cycle. -1, -2, -3,-4,-1H and -5H versions	CL=30pF, FOUT=120MHz and Measured at VDD/2	TBD	TBD	TBD	%
DC-2	Duty Cycle. -1, -2, -3,-4,-1H and -5H versions	CL=15pF, FOUT=120MHz and Measured at VDD/2	TBD	TBD	TBD	%
tr/f-1	Rise and Fall Times. -1, -2, -3, and -4 versions	Measured between 0.8V and 2.0V CL=30pF	-	-	1.6	ns
tr/f-2	Rise and Fall Times. -1, -2, -3, and -4 versions	Measured between 0.8V and 2.0V CL=15pF	-	-	1.2	ns
tr/f-3	Rise and Fall Times. -1,1H and -5H versions	Measured between 0.8V and 2.0V CL=30pF	-	-	1.2	ns
tr/f-3	Rise and Fall Times. -1H and -5H versions	Measured between 0.8V and 2.0V CL=15pF	-	-	1.0	ns
SKW-1	Output-to-Output on same bank A or B. All versions	All outputs are equally loaded. Measured at VDD/2	-	60	150	ps
SKW-2	Output Bank-A to Bank-B Skew. -1-4 and -5H versions	All outputs are equally loaded. Measured at VDD/2	-	60	150	ps
SKW-3	Output Bank-A to Bank-B Skew. -1-4 and -5H versions	All outputs are equally loaded. Measured at VDD/2	-	130	300	ps
SKW-4	Device-to-Device Skew. All versions	All outputs are equally loaded. Measured at VDD/2 and FBK pin	-	180	500	ps
tCFD	CLKIN to FBK Rising Edge Delay	All outputs are equally loaded. Measured at VDD/2	-200	-	200	ps
t2	Delay Time, CLKIN Rising Edge to CLKOUT Rising Edge <sup>[2]</sup> (Measured at VDD/2)	PLL Bypass mode	1.5	-	4.4	ns
		PLL enabled @ 3.3V	-100	-	100	ps
		PLL enabled @2.5V	-200	-	200	ps
t3	Part-to-Part Skew <sup>[2]</sup> (Measured at VDD/2)	Measured at VDD/2. Any output to any output, 3.3V supply	-	-	±150	ps
		Measured at VDD/2. Any output to any output, 2.5V supply	-	-	±300	ps
tLOCK	PLL Lock Time	Valid on all clock pins from VDD=2.97V	-	-	1.0	ms

**AC Electrical Specifications: VDD=2.5V+/-10% and -40°C to +85°C Operation (Industrial Grade)**

Symbol	Description	Condition	Min	Typ	Max	Unit
FOUT-1	Output Frequency	CL=30pf, All devices	10	-	160	MHz
FOUT-2	Output Frequency	CL=20pF, -1H and -5H versions	10	-	220	MHz
FOUT-2	Output Frequency	CL=15pF, -1,-2,-3 and -4 versions	10	-	200	MHz
DC-1	Duty Cycle. -1, -2, -3,-4,-1H and -5H versions	CL=30pF, FOUT=66.6MHz and Measured at VDD/2	40.0	50.0	60.0	%
DC-2	Duty Cycle. -1, -2, -3,-4,-1H and -5H versions	CL=15pF, FOUT<66.6MHz and Measured at VDD/2	45.0	50.0	55.0	%
DC-1	Duty Cycle. -1, -2, -3,-4,-1H and -5H versions	CL=30pF, FOUT=120MHz and Measured at VDD/2	TBD	TBD	TBD	%
DC-2	Duty Cycle. -1, -2, -3,-4,-1H and -5H versions	CL=15pF, FOUT=120MHz and Measured at VDD/2	TBD	TBD	TBD	%
tr/f-1	Rise and Fall Times. -1, -2, -3, and -4 versions	Measured between 0.8V and 2.0V CL=30pF	-	-	1.6	ns
tr/f-2	Rise and Fall Times. -1, -2, -3, and -4 versions	Measured between 0.8V and 2.0V CL=15pF	-	-	1.2	ns
tr/f-3	Rise and Fall Times. -1,1H and -5H versions	Measured between 0.8V and 2.0V CL=30pF	-	-	1.2	ns
tr/f-3	Rise and Fall Times. -1H and -5H versions	Measured between 0.8V and 2.0V CL=15pF	-	-	1.0	ns
SKW-1	Output-to-Output on same bank A or B. All versions	All outputs are equally loaded. Measured at VDD/2	-	60	150	ps
SKW-2	Output Bank-A to Bank-B Skew. -1-4 and -5H versions	All outputs are equally loaded. Measured at VDD/2	-	60	150	ps
SKW-3	Output Bank-A to Bank-B Skew. -1-4 and -5H versions	All outputs are equally loaded. Measured at VDD/2	-	130	300	ps
SKW-4	Device-to-Device Skew. All versions	All outputs are equally loaded. Measured at VDD/2	-	180	500	ps
tCFD	CLKIN to FBK Rising Edge Delay	All outputs are equally loaded. Measured at VDD/2	-200	-	200	ps
t2	Delay Time, CLKIN Rising Edge to CLKOUT Rising Edge <sup>[2]</sup> (Measured at VDD/2)	PLL Bypass mode	1.5	-	4.4	ns
		PLL enabled @ 3.3V	-100	-	100	ps
		PLL enabled @2.5V	-200	-	200	ps
t3	Part-to-Part Skew (Measured at VDD/2)	Measured at VDD/2. Any output to any output, 3.3V supply	-	-	±150	ps
		Measured at VDD/2. Any output to any output, 2.5V supply	-	-	±300	ps
tLOCK	PLL Lock Time	Valid on all clock pins from VDD=2.97V	-	-	1.0	ms

## External Components & Design Considerations

### Typical Application Schematic

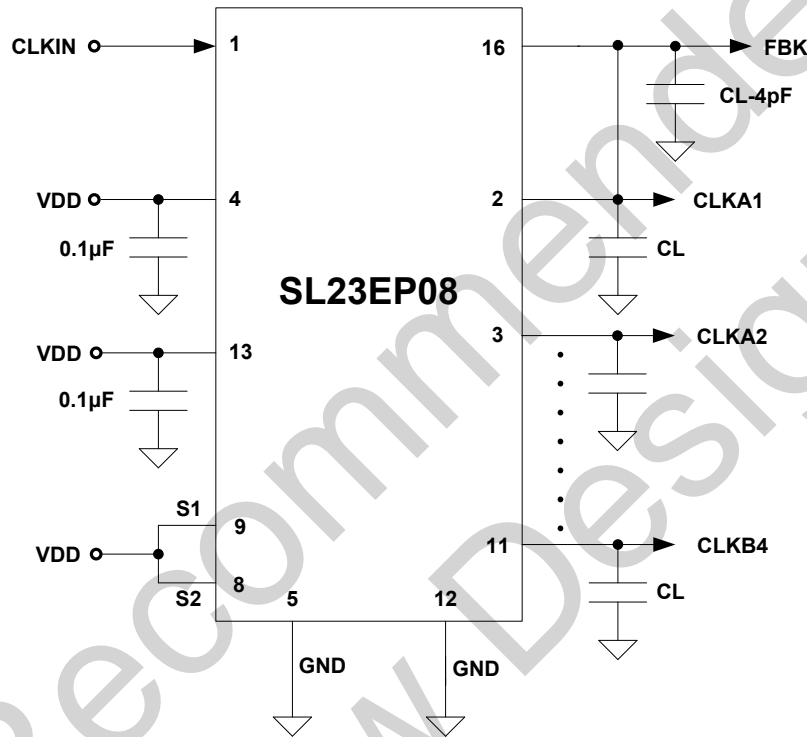

### Comments and Recommendations

**Decoupling Capacitor:** A decoupling capacitor of 0.1µF must be used between VDD and VSS pins. Place the capacitor on the component side of the PCB as close to the VDD pin as possible. The PCB trace to the VDD pin and to the GND via should be kept as short as possible. Do not use vias between the decoupling capacitor and the VDD pin.

**Series Termination Resistor:** A series termination resistor is recommended if the distance between the output clocks and the load is over 1 ½ inch. The nominal impedance of the clock outputs is given on the page 4. Place the series termination resistors as close to the clock outputs as possible.

**Zero Delay and Skew Control:** All outputs and CLKIN pins should be loaded with the same load to achieve “Zero Delay” between the CLKIN and the outputs. The CLKOUT pin is connected to CLKIN internally on-chip for feedback to PLL, and sees an additional 4 pF load with respect to Bank A and B clocks. For applications requiring zero input/output delay, the load at the all output pins including the CLKOUT pin must be the same. If any delay adjustment is required, the capacitance at the CLKOUT pin could be increased or decreased to increase or decrease the delay between Bank A and B clocks and CLKIN.

For minimum pin-to-pin skew, the external load at all the Bank A and B clocks must be the same.

Switching Waveforms

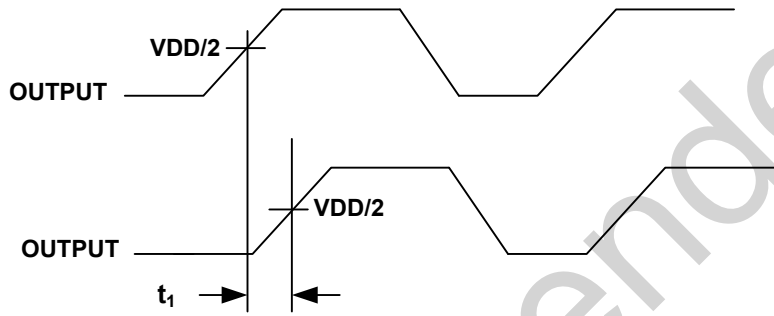

Figure 2. Output to Output Skew

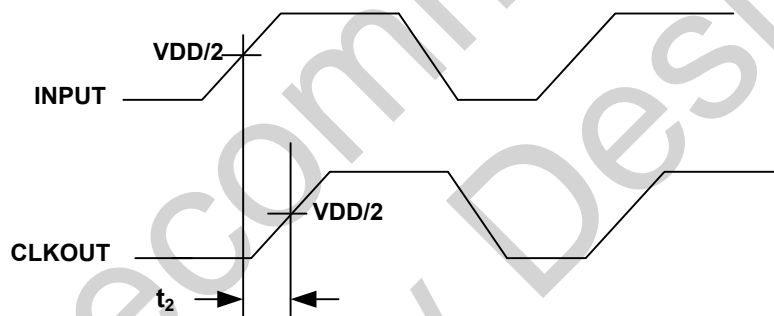

Figure 3. Input to Output Skew

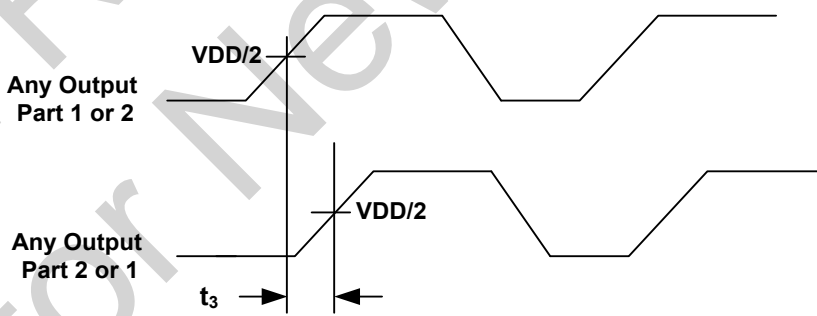
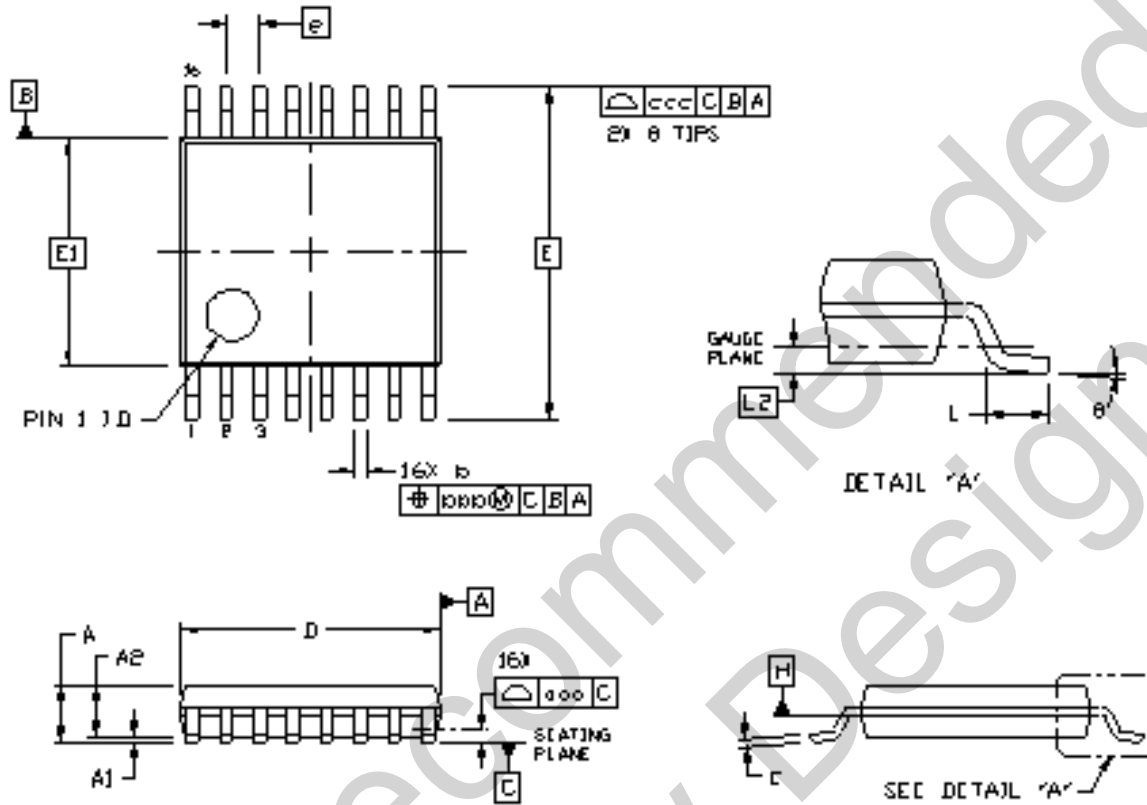

Figure 4. Part-to-Part Skew

**Package Drawing and Dimensions: 16-Lead TSSOP (4.4 mm)**



Dimension	MIN	NOM	MAX
A	--	--	1.20
A1	0.05	--	0.15
A2	0.80	1.00	1.05
b	0.19	--	0.30
c	0.09	--	0.20
D	4.90	5.00	5.10
E	6.40 BSC		
E1	4.30	4.40	4.50
e	0.65 BSC		
L	0.45	0.60	0.75
L2	0.25 BSC		
θ	0°	--	8°
aaa	0.10		
bbb	0.10		
ccc	0.20		

**Thermal Characteristics**

Parameter	Symbol	Condition	Min	Typ	Max	Unit
Thermal Resistance Junction to Ambient	$\theta_{JA}$	Still air	-	80	-	°C/W
	$\theta_{JA}$	1m/s air flow	-	70	-	°C/W
	$\theta_{JA}$	3m/s air flow	-	68	-	°C/W
Thermal Resistance Junction to Case	$\theta_{JC}$	Independent of air flow	-	36	-	°C/W

Not Recommended  
for New Designs

**Package Drawing and Dimensions: 16-Lead SOIC (150 Mil)**

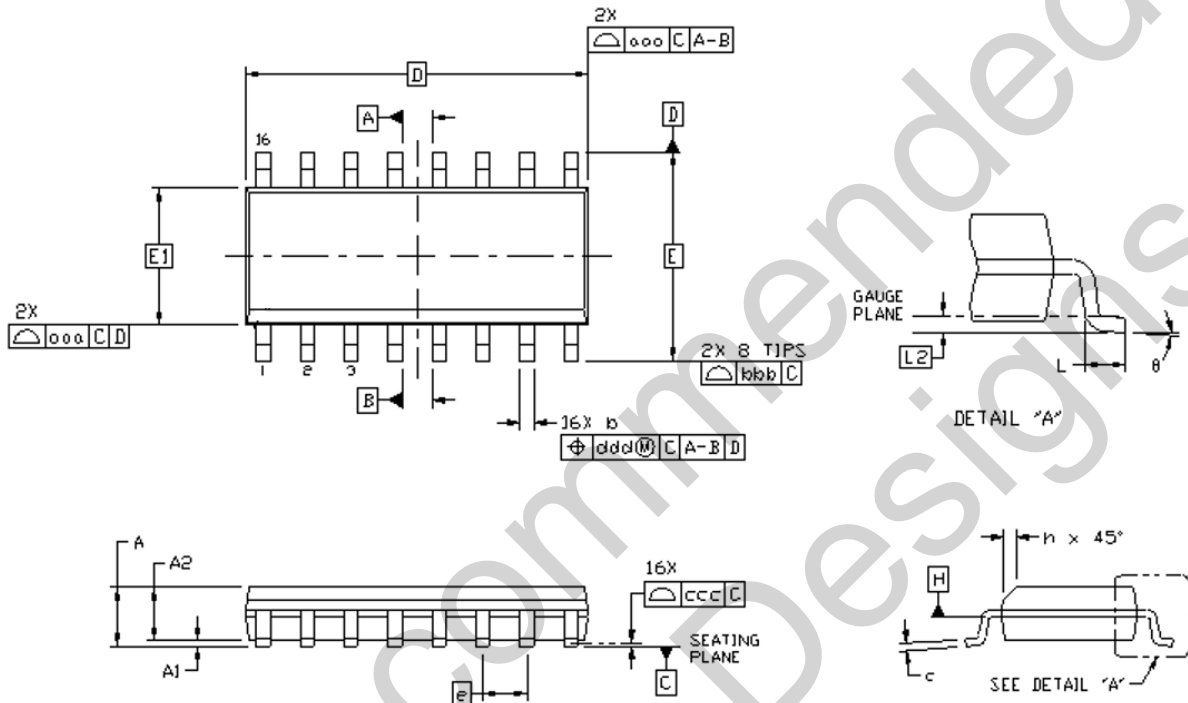

Dimension	MIN	MAX
A	--	1.68
A1	0.10	0.25
A2	1.30	1.50
b	0.35	0.49
c	0.19	0.25
D	10.10 BSC	
E	6.00 BSC	
E1	3.90 BSC	
e	1.27 BSC	
L	0.56	0.82
L2	0.25 BSC	
h	0.30 REF	
θ	0°	8°
aaa	0.10	
bbb	0.20	
ccc	0.10	
ddd	0.25	

**Thermal Characteristics**

Parameter	Symbol	Condition	Min	Typ	Max	Unit
Thermal Resistance Junction to Ambient	$\theta_{JA}$	Still air	-	120	-	°C/W
	$\theta_{JA}$	1m/s air flow	-	115	-	°C/W
	$\theta_{JA}$	3m/s air flow	-	105	-	°C/W
Thermal Resistance Junction to Case	$\theta_{JC}$	Independent of air flow	-	60	-	°C/W

Not Recommended for New Designs

**Ordering Information** <sup>[3]</sup>

Ordering Number	Marking	Shipping Package	Package	Temperature
SL23EP08SC-1	SL23EP08SC-1	Tube	16-pin SOIC	0 to 70°C
SL23EP08SC-1T	SL23EP08SC-1	Tape and Reel	16-pin SOIC	0 to 70°C
SL23EP08SI-1	SL23EP08SI-1	Tube	16-pin SOIC	-40 to 85°C
SL23EP08SI-1T	SL23EP08SI-1	Tape and Reel	16-pin SOIC	-40 to 85°C
SL23EP08SC-1H	SL23EP08SC-1H	Tube	16-pin SOIC	0 to 70°C
SL23EP08SC-1HT	SL23EP08SC-1H	Tape and Reel	16-pin SOIC	0 to 70°C
SL23EP08SI-1H	SL23EP08SI-1H	Tube	16-pin SOIC	-40 to 85°C
SL23EP08SI-1HT	SL23EP08SI-1H	Tape and Reel	16-pin SOIC	-40 to 85°C
SL23EP08ZC-1H	SL23EP08ZC-1H	Tube	16-pin TSSOP	0 to 70°C
SL23EP08ZC-1HT	SL23EP08ZC-1H	Tape and Reel	16-pin TSSOP	0 to 70°C
SL23EP08ZI-1H	SL23EP08ZI-1H	Tube	16-pin TSSOP	-40 to 85°C
SL23EP08ZI-1HT	SL23EP08ZI-1H	Tape and Reel	16-pin TSSOP	-40 to 85°C
SL23EP08SC-2	SL23EP08SC-2	Tube	16-pin SOIC	0 to 70°C
SL23EP08SC-2T	SL23EP08SC-2	Tape and Reel	16-pin SOIC	0 to 70°C
SL23EP08SI-2	SL23EP08SI-2	Tube	16-pin SOIC	-40 to 85°C
SL23EP08SI-2T	SL23EP08SI-2	Tape and Reel	16-pin SOIC	-40 to 85°C
SL23EP08SC-3	SL23EP08SC-3	Tube	16-pin SOIC	0 to 70°C
SL23EP08SC-3T	SL23EP08SC-3	Tape and Reel	16-pin SOIC	0 to 70°C
SL23EP08SI-3	SL23EP08SI-3	Tube	16-pin SOIC	-40 to 85°C
SL23EP08SI-3T	SL23EP08SI-3	Tape and Reel	16-pin SOIC	-40 to 85°C
SL23EP08SC-4	SL23EP08SC-4	Tube	16-pin SOIC	0 to 70°C
SL23EP08SC-4T	SL23EP08SC-4	Tape and Reel	16-pin SOIC	0 to 70°C
SL23EP08SI-4	SL23EP08SI-4	Tube	16-pin SOIC	-40 to 85°C
SL23EP08SI-4T	SL23EP08SI-4	Tape and Reel	16-pin SOIC	-40 to 85°C
SL23EP08SC-5H	SL23EP08SC-5H	Tube	16-pin SOIC	0 to 70°C
SL23EP08SC-5HT	SL23EP08SC-5H	Tape and Reel	16-pin SOIC	0 to 70°C

Notes:

- The SL23EP08 products are RoHS compliant.



Smart.  
Connected.  
Energy-Friendly



**Products**  
[www.silabs.com/products](http://www.silabs.com/products)



**Quality**  
[www.silabs.com/quality](http://www.silabs.com/quality)



**Support and Community**  
[community.silabs.com](http://community.silabs.com)

**Disclaimer**  
Silicon Laboratories intends to provide customers with the latest, accurate, and in-depth documentation of all peripherals and modules available for system and software implementers using or intending to use the Silicon Laboratories products. Characterization data, available modules and peripherals, memory sizes and memory addresses refer to each specific device, and "Typical" parameters provided can and do vary in different applications. Application examples described herein are for illustrative purposes only. Silicon Laboratories reserves the right to make changes without further notice and limitation to product information, specifications, and descriptions herein, and does not give warranties as to the accuracy or completeness of the included information. Silicon Laboratories shall have no liability for the consequences of use of the information supplied herein. This document does not imply or express copyright licenses granted hereunder to design or fabricate any integrated circuits. The products are not designed or authorized to be used within any Life Support System without the specific written consent of Silicon Laboratories. A "Life Support System" is any product or system intended to support or sustain life and/or health, which, if it fails, can be reasonably expected to result in significant personal injury or death. Silicon Laboratories products are not designed or authorized for military applications. Silicon Laboratories products shall under no circumstances be used in weapons of mass destruction including (but not limited to) nuclear, biological or chemical weapons, or missiles capable of delivering such weapons.

**Trademark Information**  
Silicon Laboratories Inc.®, Silicon Laboratories®, Silicon Labs®, SiLabs® and the Silicon Labs logo®, Bluegiga®, Bluegiga Logo®, Clockbuilder®, CMEMS®, DSPLL®, EFM®, EFM32®, EFR®, Ember®, Energy Micro, Energy Micro logo and combinations thereof, "the world's most energy friendly microcontrollers", Ember®, EZLink®, EZRadio®, EZRadioPRO®, Gecko®, ISOModem®, Precision32®, ProSLIC®, Simplicity Studio®, SiPHY®, Telegesis, the Telegesis Logo®, USBXpress® and others are trademarks or registered trademarks of Silicon Laboratories Inc. ARM, CORTEX, Cortex-M3 and THUMB are trademarks or registered trademarks of ARM Holdings. Keil is a registered trademark of ARM Limited. All other products or brand names mentioned herein are trademarks of their respective holders.



Silicon Laboratories Inc.  
400 West Cesar Chavez  
Austin, TX 78701  
USA  
<http://www.silabs.com>

## Looking for pricing, stock, or lifecycle information?

Click below to explore more details on WIN SOURCE:

- ⊖ [View SL23EP08SC-2T on WIN SOURCE](#)
- ⊖ [Skyworks Solutions Inc. Information](#)

## Optimize Your Supply Chain with WIN SOURCE Solutions

- ✓ Global Sourcing Solution
- ✓ Obsolete Management
- ✓ Cost Control Management
- ✓ Shortage Management
- ✓ Alternative Solution
- ✓ Excess Inventory Management