

Description

The 5PB11xx is a high-performance LVCMOS clock buffer family of devices. It has an additive phase jitter of 50fs RMS.

There are five different fan-out variations available: 1:2 to 1:10.

The 5PB11xx supports a synchronous glitch-free output enable (OE) function to eliminate any potential intermediate incorrect output clock cycles when enabling or disabling outputs. It can operate from a 1.8V to 3.3V supply.

Typical Applications

- Industrial applications
- Automotive:
 - Radar, Lidar, and other applications

Features

- High-performance 1:2, 1:4, 1:6, 1:8, 1:10 LVCMOS clock buffer
- Very low pin-to-pin skew: < 50ps
- Very low additive jitter: < 50fs
- Supply voltage: 1.8V to 3.3V
- 3.3V tolerant input clock
- $f_{MAX} = 200\text{MHz}$
- Integrated serial termination for 50Ω channel
- Packaged in 8-, 14-, 16-, 20-pin TSSOP and as small as 2.0 × 2.0 mm DFN and 3.0 × 3.0 mm VFQFPN packages
- Industrial (-40°C to +85°C) and extended (-40°C to +105°C) temperature ranges
- 5PB1104 available in AEC-Q100 qualified, Automotive Grade 1 (-40°C to +125°C)
- 5PB1110 available in AEC-Q100 qualified, Automotive Grade 2 (-40°C to +105°C)

Block Diagram

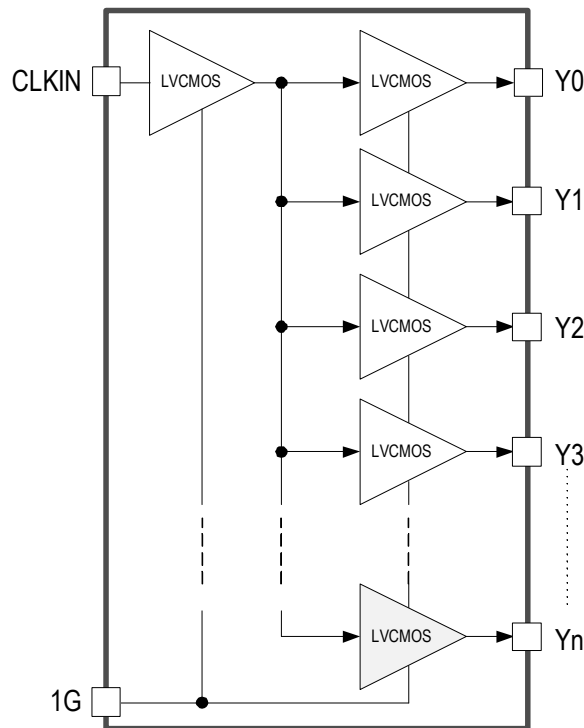

Contents

| | |
|---|----|
| Description | 1 |
| Typical Applications | 1 |
| Features | 1 |
| Block Diagram | 1 |
| Pin Assignments – TSSOP Packages | 3 |
| Pin Descriptions – TSSOP Packages | 3 |
| Pin Assignments – DFN/VFQFPN Packages | 4 |
| Pin Descriptions – DFN/VFQFPN Packages | 4 |
| Output Logic Table | 5 |
| Absolute Maximum Ratings | 5 |
| Recommended Operating Conditions | 5 |
| Thermal Characteristics | 6 |
| DC Electrical Characteristics | 7 |
| AC Electrical Characteristics | 13 |
| Phase Noise Plots | 19 |
| Test Load and Circuit | 20 |
| Package Outline Drawings | 20 |
| Marking Diagrams (Industrial) | 20 |
| Marking Diagrams (Extended) | 21 |
| Marking Diagrams (Automotive) | 21 |
| Ordering Information (Industrial) | 22 |
| Ordering Information (Extended) | 23 |
| Ordering Information (Automotive) | 23 |
| Ordering Information (Special Material Request) | 24 |
| Revision History | 24 |

Pin Assignments – DFN/VFQFPN Packages

Figure 2. Pin Assignments for DFN/QFN Packages

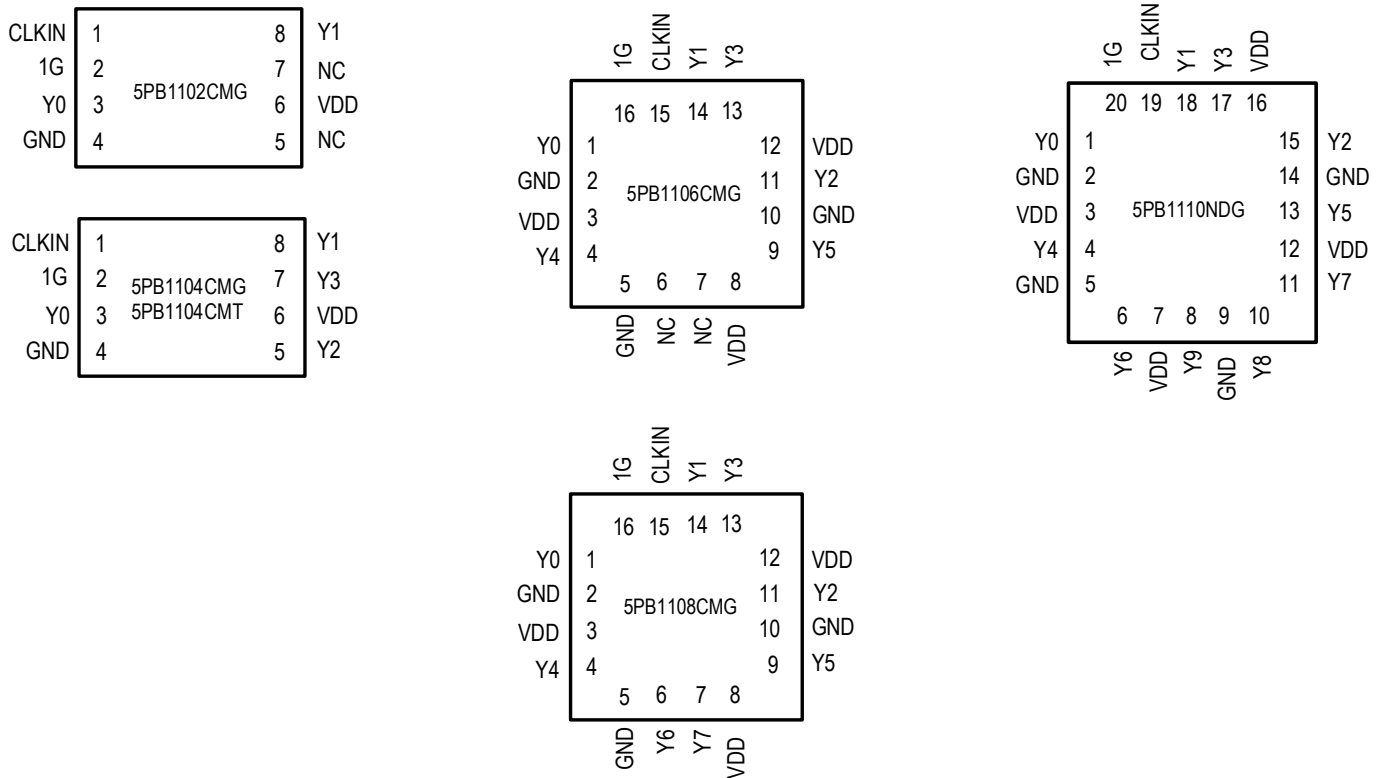

Pin Descriptions – DFN/VFQFPN Packages

Table 2. Pin Descriptions for DFN/VFQFPN Packages

| Device Number | LVC MOS Clock Input | Clock Output Enable | LVC MOS Clock Output | Supply Voltage | Ground |
|--------------------------|---------------------|---------------------|------------------------------------|-----------------|-------------|
| | CLKIN | 1G | Y0, Y1, ... Y9 | V _{DD} | GND |
| 5PB1102CMG | 1 | 2 | 3, 8 | 6 | 4 |
| 5PB1104CMG 5PB1104CMT | 1 | 2 | 3, 5, 7, 8 | 6 | 4 |
| 5PB1106CMG | 15 | 16 | 1, 4, 9, 11, 13, 14 | 3, 8, 12 | 2, 5, 10 |
| 5PB1108CMG | 15 | 16 | 1, 4, 6, 7, 9, 11, 13, 14 | 3, 8, 12 | 2, 5, 10 |
| 5PB1110NDG | 19 | 20 | 1, 4, 6, 8, 10, 11, 13, 15, 17, 18 | 3, 7, 12, 16 | 2, 5, 9, 14 |

Output Logic Table

| Inputs | | Output |
|--------|----|--------|
| CLKIN | 1G | Yn |
| X | L | L |
| L | H | L |
| H | H | H |

After at least three cycles of input clock toggling. Output Enable function is asynchronous to eliminate any intermediate incorrect output clock cycles during transition which may cause frequency peaking to the downstream device.

Absolute Maximum Ratings

The absolute maximum ratings are stress ratings only. Stresses greater than those listed below can cause permanent damage to the device. Functional operation of the 5PB11xx at absolute maximum ratings is not implied. Exposure to absolute maximum rating conditions may affect device reliability.

Table 3. Absolute Maximum Ratings

| Item | Rating |
|---|----------------------------|
| Supply Voltage, V_{DD} | 3.8V |
| Output Enable and All Outputs | -0.4 V to $V_{DD} + 0.5$ V |
| Input Voltage, CLKIN | -0.4 V to 3.465V |
| Ambient Operating Temperature (Industrial) | -40 to +85°C |
| Ambient Operating Temperature (Extended and Automotive Grade 2) | -40 to +105°C |
| Ambient Operating Temperature (Automotive Grade 1) | -40 to +125°C |
| Storage Temperature | -65 to +150°C |
| Junction Temperature | 125°C |
| Soldering Temperature | 260°C |

Recommended Operating Conditions

Table 4. Recommended Operating Conditions

| Parameter | Minimum | Typical | Maximum | Unit |
|---|---------|---------|---------|------|
| Ambient Operating Temperature (Industrial) | -40 | - | +85 | °C |
| Ambient Operating Temperature (Extended and Automotive Grade 2) | -40 | - | +105 | |
| Ambient Operating Temperature (Automotive Grade 1) | -40 | - | +125 | |
| Power Supply Voltage (measured in respect to GND) | +1.71 | - | +3.465 | V |

Thermal Characteristics

Table 5. Thermal Characteristics

| Package | Applies to | θ_{JA} | θ_{JC} | θ_{JB} | Unit |
|-----------|--------------------------------------|---------------|---------------|---------------|-----------------|
| 8-TSSOP | 5PB1102PGG, 5PB1104PGG | 122.0 | 58.2 | 139.3 | °C/W; still air |
| 14-TSSOP | 5PB1106PGG | 84.5 | 44.2 | 64.5 | °C/W; still air |
| 16-TSSOP | 5PB1108PGG | 80.9 | 43.3 | 60.1 | °C/W; still air |
| 20-TSSOP | 5PB1110PGG | 72.5 | 37.9 | 49.8 | °C/W; still air |
| 8-DFN | 5PB1102CMG, 5PB1104CMG 5PB1104CMT | 120.2 | 99.4 | 63.3 | °C/W; still air |
| 16-VFQFPN | 5PB1106CMG, 5PB1108CMG | 115.6 | 83.1 | 61.8 | °C/W; still air |
| 20-VFQFPN | 5PB1110NDG | 49.6 | 94.7 | 5.1 | °C/W; still air |

DC Electrical Characteristics

$V_{DD} = 1.8V, 2.5V, \text{ or } 3.3V$ (see tables below)

Table 6. DC Electrical Characteristics – $V_{DD} = 1.8V \pm 5\%$, Industrial and Extended

| Symbol | Parameter | Applies to | Conditions | Minimum | Typical | Maximum | Unit |
|----------|--|--|------------------------|---------|---------------------|----------|------|
| V_{DD} | Operating Voltage | Industrial and Extended ^[2] | | 1.71 | 1.8 | 1.89 | V |
| V_{IH} | Input High Voltage, CLKIN ^[1] | | $0.7 \times V_{DD}$ | - | - | V | |
| V_{IL} | Input Low Voltage, CLKIN ^[1] | | - | - | $0.3 \times V_{DD}$ | V | |
| V_{IH} | Input High Voltage, 1G | | 1.6 | - | V_{DD} | V | |
| V_{IL} | Input Low Voltage, 1G | | - | - | 0.6 | V | |
| V_{OH} | Output High Voltage | | $I_{OH} = -5mA.$ | 1.4 | - | - | V |
| V_{OL} | Output Low Voltage | | $I_{OL} = 5mA.$ | - | - | 0.4 | V |
| Z_O | Nominal Output Impedance | | - | 50 | - | Ω | |
| C_{IN} | Input Capacitance | | CLKIN, 1G pin. | - | 5 | - | pF |
| I_{DD} | Operating Supply Current, 5PB1102 | | 100MHz, no load, 25°C. | - | 6 | 8 | mA |
| | Operating Supply Current, 5PB1104 | | | - | 12 | 13 | |
| | Operating Supply Current, 5PB1106 | | | - | 15 | 18 | |
| | Operating Supply Current, 5PB1108 | | | - | 20 | 23 | |
| | Operating Supply Current, 5PB1110 | | | - | 23 | 27 | |
| I_{IH} | Input High Leakage | $V_{IN} = V_{DD}$ | - | - | 5 | μA | |
| I_{IL} | Input Low Leakage | $V_{IN} = 0V$ | - | - | 5 | μA | |

^[1] Nominal switching threshold is $V_{DD}/2$.

^[2] 5PB11xxPGGI, 5PB11xxPGGK, 5PB11xxCMGI, 5PB11xxCMGK. $T_A = -40^\circ C$ to $+105^\circ C$ unless stated otherwise.

Table 7. DC Electrical Characteristics – $V_{DD} = 1.8V \pm 5\%$, Automotive

| Symbol | Parameter | Applies to | Conditions | Minimum | Typical | Maximum | Unit |
|----------|-------------------------------|-------------------|-------------------------|---------|---------------------|---------|----------|
| V_{DD} | Operating Voltage | Automotive [2][3] | | 1.71 | 1.8 | 1.89 | V |
| V_{IH} | Input High Voltage, CLKIN [1] | | $0.7 \times V_{DD}$ | - | - | V | |
| V_{IL} | Input Low Voltage, CLKIN [1] | | - | - | $0.3 \times V_{DD}$ | V | |
| V_{IH} | Input High Voltage, 1G | | 1.6 | - | V_{DD} | V | |
| V_{IL} | Input Low Voltage, 1G | | - | - | 0.6 | V | |
| V_{OH} | Output High Voltage | | $I_{OH} = -5mA.$ | 1.2 | - | - | V |
| V_{OL} | Output Low Voltage | | $I_{OL} = 5mA.$ | - | - | 0.45 | V |
| Z_O | Nominal Output Impedance | | | - | 50 | - | Ω |
| C_{IN} | Input Capacitance | | CLKIN, 1G pin. | - | 5 | - | pF |
| I_{DD} | Operating Supply Current | 5PB1104 [2] | 0.001MHz, $C_L = 5pF.$ | - | 0.7 | 1 | mA |
| | | | 0.008MHz, $C_L = 5pF.$ | - | 0.7 | 1 | |
| | | | 40MHz, $C_L = 5pF.$ | - | 11 | 13 | |
| | | | 100MHz, $C_L = 5pF.$ | - | 25 | 30 | |
| | | | 156.25MHz, $C_L = 5pF.$ | - | 37 | 47 | |
| | | | 200MHz, $C_L = 5pF.$ | - | 39 | 57 | |
| I_{DD} | Operating Supply Current | 5PB1110 [3] | 0.001MHz, $C_L = 5pF.$ | - | 4.1 | 6.7 | mA |
| | | | 0.008MHz, $C_L = 5pF.$ | - | 4.2 | 6.7 | |
| | | | 40MHz, $C_L = 5pF.$ | - | 30 | 45 | |
| | | | 100MHz, $C_L = 5pF.$ | - | 65 | 82 | |
| | | | 156.25MHz, $C_L = 5pF.$ | - | 91 | 123 | |
| | | | 200MHz, $C_L = 5pF.$ | - | 96 | 137 | |
| I_{IH} | Input High Leakage | Automotive [2][3] | $V_{IN} = V_{DD}$ | - | - | 5 | μA |
| I_{IL} | Input Low Leakage | | $V_{IN} = 0V$ | - | - | 5 | μA |

[1] Nominal switching threshold is $V_{DD}/2$.

[2] 5PB1104CMG1 and 5PB1104CMT1 $T_A = -40^\circ C$ to $+125^\circ C$ unless stated otherwise.

[3] 5PB1110NDG2 $T_A = -40^\circ C$ to $+105^\circ C$ unless stated otherwise.

Table 8. DC Electrical Characteristics – $V_{DD} = 2.5V \pm 5\%$, Industrial and Extended

| Symbol | Parameter | Applies to | Conditions | Minimum | Typical | Maximum | Unit |
|----------|--|--|------------------------|---------|---------------------|----------|------|
| V_{DD} | Operating Voltage | Industrial and Extended ^[2] | | 2.375 | 2.5 | 2.625 | V |
| V_{IH} | Input High Voltage, CLKIN ^[1] | | $0.7 \times V_{DD}$ | - | - | V | |
| V_{IL} | Input Low Voltage, CLKIN ^[1] | | - | - | $0.3 \times V_{DD}$ | V | |
| V_{IH} | Input High Voltage, 1G | | 1.8 | - | V_{DD} | V | |
| V_{IL} | Input Low Voltage, 1G | | - | - | 0.7 | V | |
| V_{OH} | Output High Voltage | | $I_{OH} = -8mA.$ | 1.9 | - | - | V |
| V_{OL} | Output Low Voltage | | $I_{OL} = 8mA.$ | - | - | 0.5 | V |
| Z_O | Nominal Output Impedance | | - | 50 | - | Ω | |
| C_{IN} | Input Capacitance | | CLKIN, 1G pin. | - | 5 | - | pF |
| I_{DD} | Operating Supply Current, 5PB1102 | | 100MHz, no load, 25°C. | - | 9 | 11 | mA |
| | Operating Supply Current, 5PB1104 | | | - | 15 | 18 | |
| | Operating Supply Current, 5PB1106 | | | - | 21 | 24 | |
| | Operating Supply Current, 5PB1108 | | | - | 27 | 31 | |
| | Operating Supply Current, 5PB1110 | | | - | 32 | 37 | |
| I_{IH} | Input High Leakage | $V_{IN} = V_{DD}$ | - | - | 5 | μA | |
| I_{IL} | Input Low Leakage | $V_{IN} = 0V$ | - | - | 5 | μA | |

^[1] Nominal switching threshold is $V_{DD}/2$.

^[2] 5PB11xxPGGI, 5PB11xxPGGK, 5PB11xxCMGI, 5PB11xxCMGK. $T_A = -40^\circ C$ to $+105^\circ C$ unless stated otherwise.

Table 9. DC Electrical Characteristics – $V_{DD} = 2.5V \pm 5\%$, Automotive

| Symbol | Parameter | Applies to | Conditions | Minimum | Typical | Maximum | Unit |
|----------|-------------------------------|-------------------|-------------------------|---------|---------------------|---------|----------|
| V_{DD} | Operating Voltage | Automotive [2][3] | | 2.375 | 2.5 | 2.625 | V |
| V_{IH} | Input High Voltage, CLKIN [1] | | $0.7 \times V_{DD}$ | - | - | V | |
| V_{IL} | Input Low Voltage, CLKIN [1] | | - | - | $0.3 \times V_{DD}$ | V | |
| V_{IH} | Input High Voltage, 1G | | 1.8 | - | V_{DD} | V | |
| V_{IL} | Input Low Voltage, 1G | | - | - | 0.7 | V | |
| V_{OH} | Output High Voltage | | $I_{OH} = -8mA.$ | 1.6 | - | - | V |
| V_{OL} | Output Low Voltage | | $I_{OL} = 8mA.$ | - | - | 0.625 | V |
| Z_O | Nominal Output Impedance | | | - | 50 | - | Ω |
| C_{IN} | Input Capacitance | | CLKIN, 1G pin. | - | 5 | - | pF |
| I_{DD} | Operating Supply Current | 5PB1104 [2] | 0.001MHz, $C_L = 5pF.$ | - | 0.9 | 1.3 | mA |
| | | | 0.008MHz, $C_L = 5pF.$ | - | 0.9 | 1.3 | |
| | | | 40MHz, $C_L = 5pF.$ | - | 15 | 17 | |
| | | | 100MHz, $C_L = 5pF.$ | - | 35 | 42 | |
| | | | 156.25MHz, $C_L = 5pF.$ | - | 52 | 67 | |
| | | | 200MHz, $C_L = 5pF.$ | - | 56 | 80 | |
| I_{DD} | Operating Supply Current | 5PB1110 [3] | 0.001MHz, $C_L = 5pF.$ | - | 5.4 | 8.2 | mA |
| | | | 0.008MHz, $C_L = 5pF.$ | - | 5.4 | 8.2 | |
| | | | 40MHz, $C_L = 5pF.$ | - | 41 | 61 | |
| | | | 100MHz, $C_L = 5pF.$ | - | 91 | 116 | |
| | | | 156.25MHz, $C_L = 5pF.$ | - | 129 | 169 | |
| | | | 200MHz, $C_L = 5pF.$ | - | 140 | 195 | |
| I_{IH} | Input High Leakage | Automotive [2][3] | $V_{IN} = V_{DD}$ | - | - | 5 | μA |
| I_{IL} | Input Low Leakage | | $V_{IN} = 0V$ | - | - | 5 | μA |

[1] Nominal switching threshold is $V_{DD}/2$.

[2] 5PB1104CMG1 and 5PB1104CMT1 $T_A = -40^\circ C$ to $+125^\circ C$ unless stated otherwise.

[3] 5PB1110NDG2 $T_A = -40^\circ C$ to $+105^\circ C$ unless stated otherwise.

Table 10. DC Electrical Characteristics – $V_{DD} = 3.3V \pm 5\%$, Industrial and Extended

| Symbol | Parameter | Applies to | Conditions | Minimum | Typical | Maximum | Unit |
|----------|--|--|------------------------|---------|---------------------|----------|------|
| V_{DD} | Operating Voltage | Industrial and Extended ^[2] | | 3.135 | 3.3 | 3.465 | V |
| V_{IH} | Input High Voltage, CLKIN ^[1] | | $0.7 \times V_{DD}$ | - | - | V | |
| V_{IL} | Input Low Voltage, CLKIN ^[1] | | - | - | $0.3 \times V_{DD}$ | V | |
| V_{IH} | Input High Voltage, 1G | | 2.0 | - | V_{DD} | V | |
| V_{IL} | Input Low Voltage, 1G | | - | - | 0.8 | V | |
| V_{OH} | Output High Voltage | | $I_{OH} = -12mA.$ | 2.4 | - | - | V |
| V_{OL} | Output Low Voltage | | $I_{OL} = 12mA.$ | - | - | 0.7 | V |
| Z_O | Nominal Output Impedance | | - | 50 | - | Ω | |
| C_{IN} | Input Capacitance | | CLKIN, 1G pin. | - | 5 | - | pF |
| I_{DD} | Operating Supply Current, 5PB1102 | | 100MHz, no load, 25°C. | - | 12 | 13 | mA |
| | Operating Supply Current, 5PB1104 | | | - | 20 | 22 | |
| | Operating Supply Current, 5PB1106 | | | - | 25 | 30 | |
| | Operating Supply Current, 5PB1108 | | | - | 35 | 38 | |
| | Operating Supply Current, 5PB1110 | | | - | 40 | 45 | |
| I_{IH} | Input High Leakage | $V_{IN} = V_{DD}$ | - | - | 5 | μA | |
| I_{IL} | Input Low Leakage | $V_{IN} = 0V$ | - | - | 5 | μA | |

^[1] Nominal switching threshold is $V_{DD}/2$.

^[2] 5PB11xxPGGI, 5PB11xxPGGK, 5PB11xxCMGI, 5PB11xxCMGK. $T_A = -40^\circ C$ to $+105^\circ C$ unless stated otherwise.

Table 11. DC Electrical Characteristics – $V_{DD} = 3.3V \pm 5\%$, Automotive

| Symbol | Parameter | Applies to | Conditions | Minimum | Typical | Maximum | Unit |
|----------|-------------------------------|-------------------|-------------------------|---------|---------|---------|----------|
| V_{DD} | Operating Voltage | Automotive [2][3] | | 3.135 | 3.3 | 3.465 | V |
| V_{IH} | Input High Voltage, CLKIN [1] | | $0.7 \times V_{DD}$ | - | - | V | |
| V_{IL} | Input Low Voltage, CLKIN [1] | | $0.3 \times V_{DD}$ | V | | | |
| V_{IH} | Input High Voltage, 1G | | V_{DD} | V | | | |
| V_{IL} | Input Low Voltage, 1G | | 08 | V | | | |
| V_{OH} | Output High Voltage | | $I_{OH} = -12mA.$ | 2.1 | - | - | V |
| V_{OL} | Output Low Voltage | 5PB1104 [2] | $I_{OL} = 12mA.$ | - | - | 0.825 | V |
| | | 5PB1110 [3] | $I_{OL} = 12mA.$ | - | - | 0.850 | V |
| Z_O | Nominal Output Impedance | Automotive [2][3] | | - | 50 | - | Ω |
| C_{IN} | Input Capacitance | | CLKIN, 1G pin. | - | 5 | - | pF |
| I_{DD} | Operating Supply Current | 5PB1104 [2] | 0.001MHz, $C_L = 5pF.$ | - | 1.2 | 1.7 | mA |
| | | | 0.008MHz, $C_L = 5pF.$ | - | 1.2 | 1.7 | |
| | | | 40MHz, $C_L = 5pF.$ | - | 19 | 22 | |
| | | | 100MHz, $C_L = 5pF.$ | - | 45 | 54 | |
| | | | 156.25MHz, $C_L = 5pF.$ | - | 67 | 87 | |
| | | | 200MHz, $C_L = 5pF.$ | - | 75 | 107 | |
| I_{DD} | Operating Supply Current | 5PB1110 [3] | 0.001MHz, $C_L = 5pF.$ | - | 7.2 | 10.2 | mA |
| | | | 0.008MHz, $C_L = 5pF.$ | - | 7.2 | 10.2 | |
| | | | 40MHz, $C_L = 5pF.$ | - | 52 | 67 | |
| | | | 100MHz, $C_L = 5pF.$ | - | 117 | 147 | |
| | | | 156.25MHz, $C_L = 5pF.$ | - | 168 | 234 | |
| | | | 200MHz, $C_L = 5pF.$ | - | 186 | 256 | |
| I_{IH} | Input High Leakage | Automotive [2][3] | $V_{IN} = V_{DD}$ | - | - | 5 | μA |
| I_{IL} | Input Low Leakage | | $V_{IN} = 0V$ | - | - | 5 | μA |

[1] Nominal switching threshold is $V_{DD}/2$.

[2] 5PB1104CMG1 and 5PB1104CMT1 $T_A = -40^\circ C$ to $+125^\circ C$ unless stated otherwise.

[3] 5PB1110NDG2 $T_A = -40^\circ C$ to $+105^\circ C$ unless stated otherwise.

AC Electrical Characteristics

$V_{DD} = 1.8V, 2.5V, \text{ or } 3.3V$ (see tables below).

Table 12. AC Electrical Characteristics – $V_{DD} = 1.8V \pm 5\%$, Industrial and Extended

| Symbol | Parameter | Applies to | Conditions | Minimum | Typical | Maximum | Unit |
|----------------|-----------------------------------|--|--|---------|---------|---------|--------|
| - | Input Frequency | Industrial and Extended ^[1] | | 0 | - | 200 | MHz |
| t_{OR} | Output Rise Time (2pF load) | | 0.36V to 1.44V, $C_L = 2pF$. | - | 0.5 | 0.75 | ns |
| t_{OF} | Output Fall Time (2pF load) | | 1.44V to 0.36V, $C_L = 2pF$. | - | 0.5 | 0.75 | ns |
| t_{OR} | Output Rise Time (5pF load) | | 0.36V to 1.44V, $C_L = 5pF$. | - | 0.8 | 1.0 | ns |
| t_{OF} | Output Fall Time (5pF load) | | 1.44V to 0.36V, $C_L = 5pF$. | - | 0.8 | 1.0 | ns |
| $t_{START-UP}$ | Start-up Time | | Part start-up time for valid outputs after V_{DD} ramp-up. | - | - | 3 | ms |
| t_{PD} | Propagation Delay ^[2] | | | 1.5 | - | 2.5 | ns |
| - | Buffer Additive Phase Jitter, RMS | | 156.25MHz, Integration Range: 12kHz–20MHz. | - | - | 0.05 | ps |
| - | Output to Output Skew, 5PB1102/04 | | Rising edges at $V_{DD}/2$. ^[3] | - | 35 | 50 | ps |
| - | Output to Output Skew, 5PB1106 | | Rising edges at $V_{DD}/2$. ^[3] | - | 35 | 58 | ps |
| - | Output to Output Skew, 5PB1108/10 | | Rising edges at $V_{DD}/2$. ^[3] | - | 45 | 65 | ps |
| - | Device to Device Skew | | Rising edges at $V_{DD}/2$. | - | - | 200 | ps |
| t_{EN} | Output Enable Time | | $C_L \leq 5pF$. | - | - | 3 | cycles |
| t_{DIS} | Output Disable Time | | $C_L \leq 5pF$. | - | - | 3 | cycles |
| t_{DC} | Duty Cycle ^[4] | | - | 50 | - | % | |

¹ 5PB11xxPGGI, 5PB11xxPGGK, 5PB11xxCMGI, 5PB11xxCMGK. $T_A = -40^\circ C$ to $+105^\circ C$ unless stated otherwise.

² With rail-to-rail input clock.

³ Between any 2 outputs with equal loading.

⁴ Duty cycle on outputs will match incoming clock duty cycle when V_{IH} on CLKIN pin equals V_{DD} power supply voltage. Consult Renesas for tight duty cycle clock generators.

Table 13. AC Electrical Characteristics – V_{DD} = 1.8V ±5%, Automotive

| Symbol | Parameter | Applies to | Conditions | Minimum | Typical | Maximum | Unit |
|-----------------------|-----------------------------------|-------------------|---|---------|---------|---------|--------|
| - | Input Frequency | Automotive [1][5] | | 0 | - | 200 | MHz |
| t _{OR} | Output Rise Time (5pF load) | | 0.36V to 1.44V, C _L = 5pF. | - | 0.65 | 1.2 | ns |
| t _{OF} | Output Fall Time (5pF load) | 5PB1104[1] | 1.44V to 0.36V, C _L = 5pF. | - | 0.65 | 1.2 | ns |
| | | 5PB1110[5] | 1.44V to 0.36V, C _L = 5pF. | - | 0.65 | 1.25 | ns |
| t _{START-UP} | Start-up Time | 5PB1104[1] | Part start-up time for valid outputs after V _{DD} ramp-up. | - | - | 3 | ms |
| | | 5PB1110[5] | Part start-up time for valid outputs after V _{DD} ramp-up. | - | - | 3.2 | ms |
| t _{PD} | Propagation Delay [2] | 5PB1104[1] | | 1.0 | - | 3.4 | ns |
| | | 5PB1110[5] | | 1.0 | - | 4.0 | ns |
| - | Buffer Additive Phase Jitter, RMS | 5PB1104[1] | 156.25MHz, Integration Range: 12kHz–20MHz. | - | - | 0.06 | ps |
| | | 5PB1110[5] | 156.25MHz, Integration Range: 12kHz–20MHz. | - | - | 0.068 | ps |
| - | Output to Output Skew | Automotive [1][5] | Rising edges at V _{DD} /2. [3] | - | 35 | 87 | ps |
| - | Device to Device Skew | | Rising edges at V _{DD} /2. | - | - | 200 | ps |
| t _{EN} | Output Enable Time | | C _L ≤ 5pF. | - | - | 3 | cycles |
| t _{DIS} | Output Disable Time | | C _L ≤ 5pF. | - | - | 3 | cycles |
| t _{DC} | Duty Cycle [4] | | | - | 50 | - | % |

¹ 5PB1104CMG1 and 5PB1104CMT1 T_A = -40°C to +125°C unless stated otherwise.

² With rail-to-rail input clock.

³ Between any 2 outputs with equal loading.

⁴ Duty cycle on outputs will match incoming clock duty cycle when VIH on CLKIN pin equals VDD power supply voltage. Consult Renesas for tight duty cycle clock generators.

⁵ 5PB1110NDG2 T_A = -40°C to +105°C unless stated otherwise.

Table 14. AC Electrical Characteristics – $V_{DD} = 2.5V \pm 5\%$, Industrial and Extended

| Symbol | Parameter | Applies to | Conditions | Minimum | Typical | Maximum | Unit |
|----------------|--|--|--|---------|---------|---------|--------|
| - | Input Frequency | Industrial and Extended ^[1] | | 0 | - | 200 | MHz |
| t_{OR} | Output Rise Time (2pF load) | | 0.5V to 2.0V, $C_L = 2pF$. | - | 0.4 | 0.7 | ns |
| t_{OF} | Output Fall Time (2pF load) | | 2.0V to 0.5V, $C_L = 2pF$. | - | 0.4 | 0.7 | ns |
| t_{OR} | Output Rise Time (5pF load) | | 0.5V to 2.0V, $C_L = 5pF$. | - | 0.75 | 1.0 | ns |
| t_{OF} | Output Fall Time (5pF load) | | 2.0V to 0.5V, $C_L = 5pF$. | - | 0.75 | 1.0 | ns |
| $t_{START-UP}$ | Start-up Time | | Part start-up time for valid outputs after V_{DD} ramp-up. | - | - | 3 | ms |
| t_{PD} | Propagation Delay, 5PB1102/04 ^[2] | | | 1.9 | - | 2.9 | ns |
| | Propagation Delay, 5PB1106/08 ^[2] | | | 2.0 | - | 3.3 | ns |
| | Propagation Delay, 5PB1110 ^[2] | | | 2.0 | - | 3.0 | ns |
| - | Buffer Additive Phase Jitter, RMS | | 156.25MHz, Integration Range: 12kHz–20MHz. | - | - | 0.05 | ps |
| - | Output to Output Skew, 5PB1102/04 | | Rising edges at $V_{DD}/2$. ^[3] | - | 35 | 50 | ps |
| - | Output to Output Skew, 5PB1106 | | Rising edges at $V_{DD}/2$. ^[3] | - | 35 | 58 | ps |
| - | Output to Output Skew, 5PB1108/10 | | Rising edges at $V_{DD}/2$. ^[3] | - | 45 | 65 | ps |
| - | Device to Device Skew | | Rising edges at $V_{DD}/2$. | - | - | 200 | ps |
| t_{EN} | Output Enable Time | | $C_L \leq 5pF$. | - | - | 3 | cycles |
| t_{DIS} | Output Disable Time | | $C_L \leq 5pF$. | - | - | 3 | cycles |
| t_{DC} | Duty Cycle ^[4] | | - | 50 | - | % | |

¹ 5PB11xxPGGI, 5PB11xxPGGK, 5PB11xxCMGI, 5PB11xxCMGK. $T_A = -40^\circ C$ to $+105^\circ C$ unless stated otherwise.

² With rail-to-rail input clock.

³ Between any 2 outputs with equal loading.

⁴ Duty cycle on outputs will match incoming clock duty cycle when V_{IH} on CLKIN pin equals V_{DD} power supply voltage. Consult Renesas for tight duty cycle clock generators.

Table 15. AC Electrical Characteristics – V_{DD} = 2.5V ±5%, Automotive

| Symbol | Parameter | Applies to | Conditions | Minimum | Typical | Maximum | Unit |
|-----------------------|-----------------------------------|------------------------------|---|---------|---------|---------|--------|
| - | Input Frequency | Automotive ^{[1][5]} | | 0 | - | 200 | MHz |
| t _{OR} | Output Rise Time (5pF load) | | 0.5V to 2.0V, C _L = 5pF. | - | 0.63 | 1.2 | ns |
| t _{OF} | Output Fall Time (5pF load) | | 2.0V to 0.5V, C _L = 5pF. | - | 0.63 | 1.2 | ns |
| t _{START-UP} | Start-up Time | | Part start-up time for valid outputs after V _{DD} ramp-up. | - | - | 3 | ms |
| t _{PD} | Propagation Delay ^[2] | 5PB1104 ^[1] | | 1.0 | - | 4.5 | ns |
| | | 5PB1110 ^[5] | | - | - | 4.75 | ns |
| - | Buffer Additive Phase Jitter, RMS | 5PB1104 ^[1] | 156.25MHz, Integration Range: 12kHz–20MHz. | - | - | 0.06 | ps |
| | | 5PB1110 ^[5] | 156.25MHz, Integration Range: 12kHz–20MHz. | - | - | 0.065 | ps |
| - | Output to Output Skew | Automotive ^{[1][5]} | Rising edges at V _{DD} /2. ^[3] | - | 35 | 87 | ps |
| - | Device to Device Skew | | Rising edges at V _{DD} /2. | - | - | 200 | ps |
| t _{EN} | Output Enable Time | | C _L ≤ 5pF. | - | - | 3 | cycles |
| t _{DIS} | Output Disable Time | | C _L ≤ 5pF. | - | - | 3 | cycles |
| t _{DC} | Duty Cycle ^[4] | | | - | 50 | - | % |

¹ 5PB1104CMG1 and 5PB1104CMT1 T_A = -40°C to +125°C unless stated otherwise.

² With rail-to-rail input clock.

³ Between any 2 outputs with equal loading.

⁴ Duty cycle on outputs will match incoming clock duty cycle when VIH on CLKIN pin equals VDD power supply voltage. Consult Renesas for tight duty cycle clock generators.

⁵ 5PB1110NDG2 T_A = -40°C to +105°C unless stated otherwise.

Table 16. AC Electrical Characteristics – $V_{DD} = 3.3V \pm 5\%$, Industrial and Extended

| Symbol | Parameter | Applies to | Conditions | Minimum | Typical | Maximum | Unit |
|----------------|--|--|--|---------|---------|---------|--------|
| - | Input Frequency | Industrial and Extended ^[1] | | 0 | - | 200 | MHz |
| t_{OR} | Output Rise Time (2pF load) | | 0.66V to 2.64V, $C_L = 2pF$. | - | 0.45 | 0.6 | ns |
| t_{OF} | Output Fall Time (2pF load) | | 2.64V to 0.66V, $C_L = 2pF$. | - | 0.45 | 0.6 | ns |
| t_{OR} | Output Rise Time (5pF load) | | 0.66V to 2.64V, $C_L = 5pF$. | - | 0.7 | 1.0 | ns |
| t_{OF} | Output Fall Time (5pF load) | | 2.64V to 0.66V, $C_L = 5pF$. | - | 0.7 | 1.0 | ns |
| $t_{START-UP}$ | Start-up Time | | Part start-up time for valid outputs after V_{DD} ramp-up. | - | - | 3 | ms |
| t_{PD} | Propagation Delay, 5PB1102/04 ^[2] | | | 1.7 | - | 2.4 | ns |
| | Propagation Delay, 5PB1106/08 ^[2] | | | 1.7 | - | 2.7 | ns |
| | Propagation Delay, 5PB1110 ^[2] | | | 1.7 | - | 2.5 | ns |
| - | Buffer Additive Phase Jitter, RMS | | 156.25MHz, Integration Range: 12kHz–20MHz. | - | - | 0.05 | ps |
| - | Output to Output Skew, 5PB1102/04 | | Rising edges at $V_{DD}/2$. ^[3] | - | 35 | 50 | ps |
| - | Output to Output Skew, 5PB1106 | | Rising edges at $V_{DD}/2$. ^[3] | - | 35 | 58 | ps |
| - | Output to Output Skew, 5PB1108/10 | | Rising edges at $V_{DD}/2$. ^[3] | - | 45 | 65 | ps |
| - | Device to Device Skew | | Rising edges at $V_{DD}/2$. | - | - | 200 | ps |
| t_{EN} | Output Enable Time | | $C_L \leq 5pF$. | - | - | 3 | cycles |
| t_{DIS} | Output Disable Time | $C_L \leq 5pF$. | - | - | 3 | cycles | |
| t_{DC} | Duty Cycle ^[4] | | - | 50 | - | % | |

¹ 5PB11xxPGGI, 5PB11xxPGGK, 5PB11xxCMGI, 5PB11xxCMGK. $T_A = -40^\circ C$ to $+105^\circ C$ unless stated otherwise.

² With rail-to-rail input clock.

³ Between any 2 outputs with equal loading.

⁴ Duty cycle on outputs will match incoming clock duty cycle when V_{IH} on CLKIN pin equals V_{DD} power supply voltage. Consult Renesas for tight duty cycle clock generators.

Table 17. AC Electrical Characteristics – $V_{DD} = 3.3V \pm 5\%$, Automotive

| Symbol | Parameter | Applies to | Conditions | Minimum | Typical | Maximum | Unit |
|----------------|-----------------------------------|------------------------------|--|---------|---------|---------|--------|
| - | Input Frequency | Automotive ^{[1][5]} | | 0 | - | 200 | MHz |
| t_{OR} | Output Rise Time (5pF load) | | 0.66V to 2.64V, $C_L = 5pF$. | - | 0.61 | 1.2 | ns |
| t_{OF} | Output Fall Time (5pF load) | | 2.64V to 0.66V, $C_L = 5pF$. | - | 0.61 | 1.2 | ns |
| $t_{START-UP}$ | Start-up Time | | Part start-up time for valid outputs after V_{DD} ramp-up. | - | - | 3 | ms |
| t_{PD} | Propagation Delay ^[2] | 5PB1104 ^[1] | | 1.0 | - | 3.4 | ns |
| | | 5PB1110 ^[5] | | 1.0 | - | 4.0 | ns |
| - | Buffer Additive Phase Jitter, RMS | 5PB1104 ^[1] | 156.25MHz, Integration Range: 12kHz–20MHz. | - | - | 0.05 | ps |
| | | 5PB1110 ^[5] | 156.25MHz, Integration Range: 12kHz–20MHz. | - | - | 0.065 | ps |
| - | Output to Output Skew | Automotive ^{[1][5]} | Rising edges at $V_{DD}/2$. ^[3] | - | 35 | 87 | ps |
| - | Device to Device Skew | | Rising edges at $V_{DD}/2$. | - | - | 200 | ps |
| t_{EN} | Output Enable Time | | $C_L \leq 5pF$. | - | - | 3 | cycles |
| t_{DIS} | Output Disable Time | | $C_L \leq 5pF$. | - | - | 3 | cycles |
| t_{DC} | Duty Cycle ^[4] | | | - | 50 | - | % |

¹ 5PB1104CMG1 and 5PB1104CMT1 only. $T_A = -40^\circ C$ to $+125^\circ C$ unless stated otherwise.

² With rail-to-rail input clock.

³ Between any 2 outputs with equal loading.

⁴ Duty cycle on outputs will match incoming clock duty cycle when V_{IH} on CLKIN pin equals V_{DD} power supply voltage. Consult Renesas for tight duty cycle clock generators.

⁵ 5PB1110NDG2 $T_A = -40^\circ C$ to $+105^\circ C$ unless stated otherwise.

Phase Noise Plots

The phase noise plots show the low additive jitter of the 5PB11xx high-performance buffer. With an integration range of 12kHz to 20MHz, the reference input has about 58.9fs of RMS phase jitter while the output of 5PB11xx has about 70.9fs of RMS phase jitter. This results in a low additive phase jitter of only 39fs.

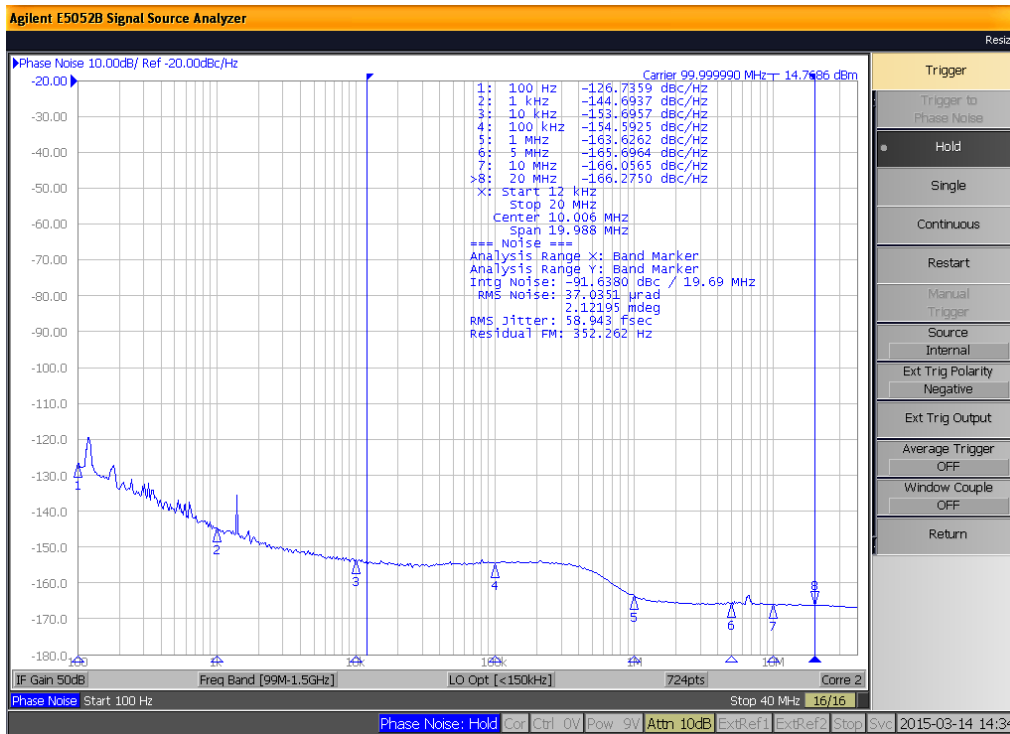

Reference Phase Noise 58.9fs (12kHz to 20MHz)

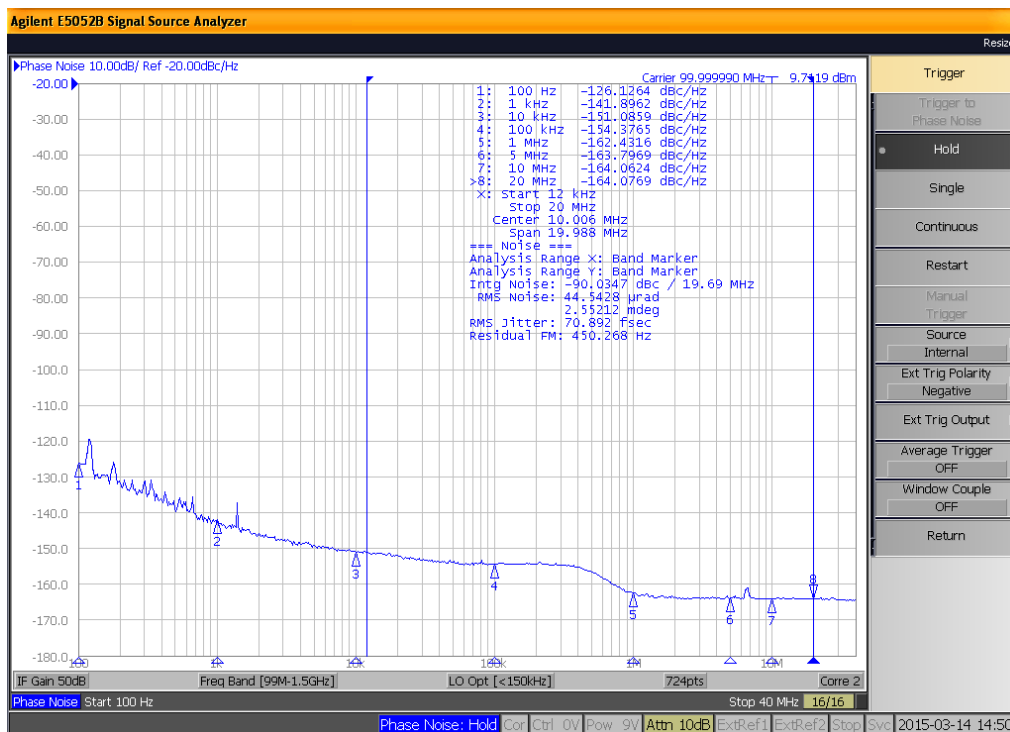

Output Phase Noise 70.9fs (12kHz to 20MHz)

Test Load and Circuit

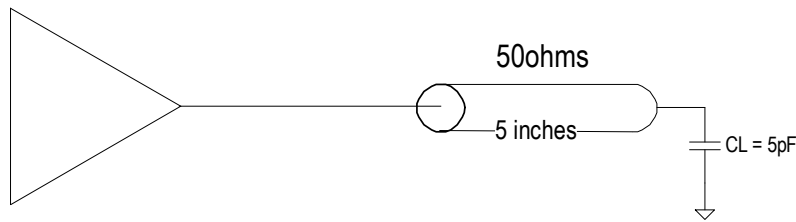

Package Outline Drawings

The package outline drawings are located at the end of this document and are accessible from the Renesas website (see the Ordering Information tables for POD links). The package information is the most current data available and is subject to change without revision of this document.

Marking Diagrams (Industrial)

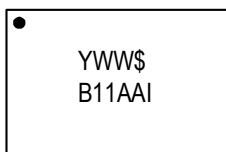

8-pin TSSOP

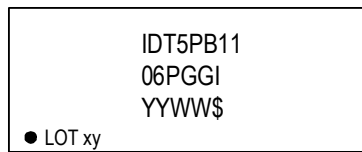

14-pin TSSOP

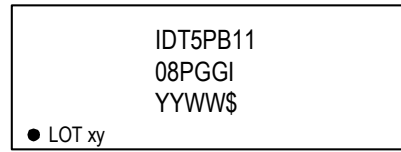

16-pin TSSOP

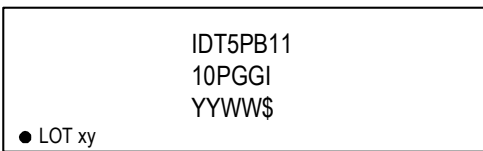

20-pin TSSOP



8-pin DFN

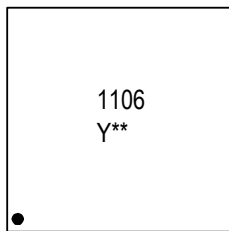

16-pin VFQFPN

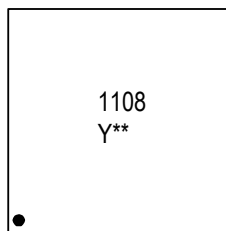

16-pin VFQFPN

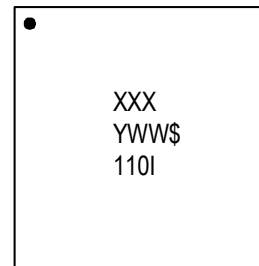

20-pin VFQFPN

- “AA” denotes the last two digits of the part number for 8-TSSOP and DFN (e.g. 02, 04).
- “**” is the lot sequence.
- “XXX” denotes the last three characters of the Asm lot (20-VFQFPN only).
- “YYWW”, “YWW”, “YW”, or “Y” is the last digit(s) of the year and work week that the part was assembled.
- “\$” denotes the mark code.
- “G” after the two-letter package code denotes RoHS compliant package.
- “I” denotes industrial temperature range device.

Marking Diagrams (Extended)



8-pin TSSOP

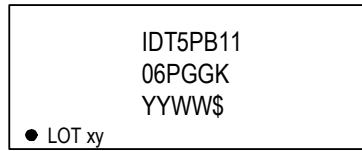

14-pin TSSOP

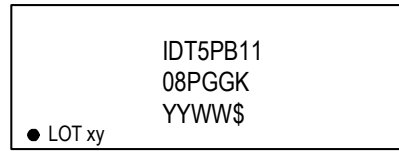

16-pin TSSOP



20-pin TSSOP



8-pin DFN

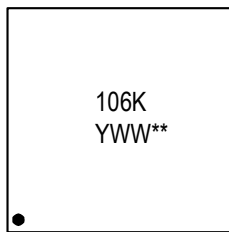

16-pin VFQFPN

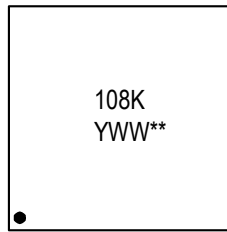

16-pin VFQFPN

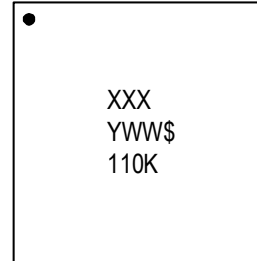

20-pin VFQFPN

- “AA” denotes the last two digits of the part number for 8-TSSOP and DFN (e.g. 02, 04).
- “**” is the lot sequence.
- “XXX” denotes the last three characters of the Asm lot (20-VFQFPN only).
- “YYWW”, “YWW”, “YW”, or “Y” is the last digit(s) of the year and week that the part was assembled.
- “\$” denotes the mark code.
- “G” after the two-letter package code denotes RoHS compliant package.
- “K” denotes extended temperature range device.

Marking Diagrams (Automotive)

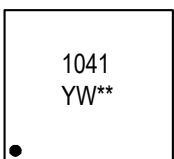

8-pin DFN

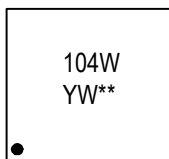

8-pin DFN (wetable flank)

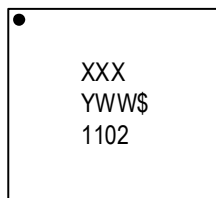

20-pin VFQFPN (wetable flank)

- Line 1:
 - For 8-pin devices: truncated part number; last number is the temperature grade: 1 = Automotive Grade 1.
 - For 20-pin device: “XXX” denotes ASM lot number.
- Line 2:
 - “YW” or “YWW” is the last digit(s) of the year and work week that the part was assembled.
 - “**” denotes the lot sequence number.
- “1102” on 20-pin device denotes truncated part number; last number is the temperature grade: 2 = Automotive Grade 2.

Ordering Information (Industrial)

| Part Number | Package | Carrier Type | Temperature Range |
|------------------------------|---------------------------------------|---------------|-------------------|
| 5PB1102PGGI | 4.4mm body, 8-TSSOP | Tubes | -40 to +85°C |
| 5PB1102PGGI8 | | Tape and Reel | |
| 5PB1104PGGI | | Tubes | |
| 5PB1104PGGI8 | | Tape and Reel | |
| 5PB1106PGGI | 4.4mm body, 14-TSSOP | Tubes | |
| 5PB1106PGGI8 | | Tape and Reel | |
| 5PB1108PGGI | 4.4mm body, 16-TSSOP | Tubes | |
| 5PB1108PGGI8 | | Tape and Reel | |
| 5PB1110PGGI | 4.4mm body, 20-TSSOP | Tubes | |
| 5PB1110PGGI8 | | Tape and Reel | |
| 5PB1102CMGI | 2.0 × 2.0 × 0.5 mm, 8-DFN | Cut Tape | |
| 5PB1102CMGI8 | | Tape and Reel | |
| 5PB1104CMGI | | Cut Tape | |
| 5PB1104CMGI8 | | Tape and Reel | |
| 5PB1104CMGI/W ^[a] | | Tape and Reel | |
| 5PB1106CMGI | 2.5 × 2.5 × 0.5 mm, 16-VFQFPN | Cut Tape | |
| 5PB1106CMGI8 | | Tape and Reel | |
| 5PB1108CMGI | | Cut Tape | |
| 5PB1108CMGI8 | | Tape and Reel | |
| 5PB1110NDGI | 3.0 × 3.0 × 0.90 mm, 20-VFQFPN | Tubes | |
| 5PB1110NDGI8 | | Tape and Reel | |

[a] "/W" stands for tape and reel with pin 1 orientation: EIA-481-D. All other tape and reels options come with EIA-481-C pin 1 orientation.

Ordering Information (Extended)

| Part Number | Package | Carrier Type | Temperature Range |
|------------------------------|---------------------------------------|---------------|-------------------|
| 5PB1102PGGK | 4.4mm body, 8-TSSOP | Tubes | -40 to +105°C |
| 5PB1102PGGK8 | | Tape and Reel | |
| 5PB1104PGGK | | Tubes | |
| 5PB1104PGGK8 | | Tape and Reel | |
| 5PB1106PGGK | 4.4mm body, 14-TSSOP | Tubes | |
| 5PB1106PGGK8 | | Tape and Reel | |
| 5PB1108PGGK | 4.4mm body, 16-TSSOP | Tubes | |
| 5PB1108PGGK8 | | Tape and Reel | |
| 5PB1110PGGK | 4.4mm body, 20-TSSOP | Tubes | |
| 5PB1110PGGK8 | | Tape and Reel | |
| 5PB1102CMGK | 2.0 × 2.0 × 0.5 mm, 8-DFN | Cut Tape | |
| 5PB1102CMGK8 | | Tape and Reel | |
| 5PB1104CMGK | | Cut Tape | |
| 5PB1104CMGK8 | | Tape and Reel | |
| 5PB1104CMGK/W ^[a] | | Tape and Reel | |
| 5PB1106CMGK | 2.5 × 2.5 × 0.5 mm, 16-VFQFPN | Cut Tape | |
| 5PB1106CMGK8 | | Tape and Reel | |
| 5PB1108CMGK | | Cut Tape | |
| 5PB1108CMGK8 | | Tape and Reel | |
| 5PB1110NDGK | 3.0 × 3.0 × 0.90 mm, 20-VFQFPN | Tubes | |
| 5PB1110NDGK8 | | Tape and Reel | |

[a] "/W" stands for tape and reel with pin 1 orientation: EIA-481-D. All other tape and reels options come with EIA-481-C pin 1 orientation.

Ordering Information (Automotive)

| Part Number | Package | Carrier Type | Temperature Range |
|--------------|---|---------------|-------------------|
| 5PB1104CMG1 | 2.0 × 2.0 × 0.5 mm, 8-DFN | Cut Tape | -40° to +125°C |
| 5PB1104CMG18 | | Tape and Reel | |
| 5PB1104CMT1 | 2.0 × 2.0 × 0.75 mm, 8-DFN, Wettable Flank | Cut Tape | -40° to +125°C |
| 5PB1104CMT18 | | Tape and Reel | |
| 5PB1110NDG2 | 3.0 × 3.0 × 0.90 mm, 20-VFQFPN, Wettable Flank | Tube | -40° to +105°C |
| 5PB1110NDG28 | | Tape and Reel | |

Ordering Information (Special Material Request)

For customers with a special material request, an alphanumeric code is assigned to the standard part number (see examples below). Contact Renesas for more information.

| Standard Part Number Example | Special Material Request Part Number ^[a] |
|------------------------------|---|
| 5PB1104CMGI | 5PB1104CMGI/X |
| 5PB1104CMGI8 | 5PB1104CMGI8/X |

[a] "/X" is a code added to the standard part number when a customer has a special request for material. If no special material is requested, "/X" can be omitted.

Revision History

| Date | Description of Change |
|--------------------|--|
| December 13, 2023 | Updated POD link for 8-DFN to CMG8D1. |
| September 15, 2023 | Updated POD links for 8-DFN and 20-VFQFPN Wettable Flank options in Ordering Information (Automotive) . |
| March 31, 2021 | Added Ordering Information (Special Material Request) table. |
| March 11, 2021 | Added 5PB1110NDG2 automotive device information. |
| January 5, 2021 | Updated supply voltage pin numbers for 5PB1110PGG in Pin Descriptions – TSSOP Packages table. |
| December 2, 2020 | <ul style="list-style-type: none"> ▪ Added 5PB1104CMG/W option to the Ordering Information (Extended) table. ▪ Updated Package Outline Drawings links. |
| September 29, 2020 | Updated marking diagrams for 5PB1106/08/10PGGI and 5PB1106/08/10PGGK. |
| January 31, 2020 | Rebranded the document as Renesas. No technical changes were made. |
| December 4, 2019 | Added Input High and Low Leakage parameters to tables 6–11. |
| May 31, 2019 | <ul style="list-style-type: none"> ▪ Added 5PB1104CMT1 wettable flank package information. ▪ Updated Propagation Delay values for automotive. |
| December 18, 2018 | <ul style="list-style-type: none"> ▪ Updated t_{PD} and skew values. ▪ Added 5PB1104CMG1 automotive part information. |
| October 24, 2018 | Initial release. |

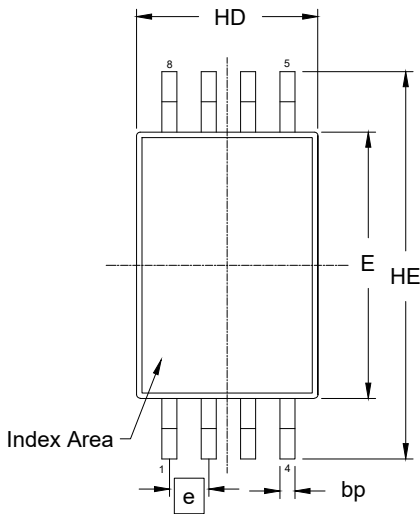

TOP VIEW

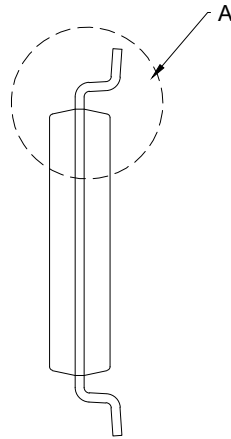

SIDE VIEW

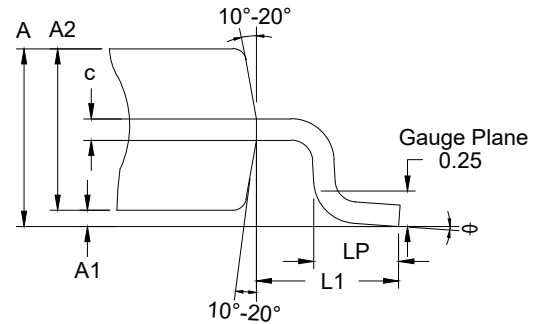

Detail A
(Rotated 90° CW)

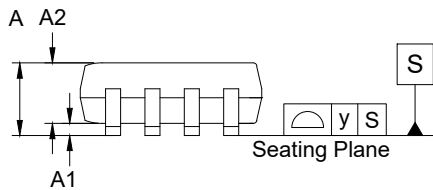

SIDE VIEW

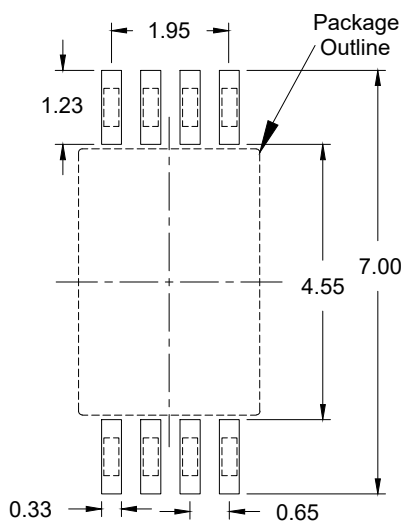

RECOMMENDED LAND PATTERN
(PCB Top View, SMD Design)

| Reference Symbol | Dimension in mm | | |
|------------------|-----------------|-------|------|
| | Min | Nom | Max |
| E | 4.30 | 4.40 | 4.50 |
| A2 | 0.80 | - | 1.05 |
| HD | 2.90 | 3.00 | 3.10 |
| HE | 6.20 | 6.40 | 6.60 |
| A | 0.85 | - | 1.20 |
| A1 | 0.05 | 0.10 | 0.15 |
| bp | 0.19 | 0.25 | 0.30 |
| c | 0.09 | - | 0.20 |
| θ | 0.00 | - | 8.00 |
| e | 0.65 BSC | | |
| y | - | - | 0.10 |
| LP | 0.50 | 0.625 | 0.75 |
| L1 | - | 1.00 | - |

NOTES:

1. JEDEC compatible.
2. All dimensions are in mm and angles are in degrees.
3. Use ± 0.05 mm for the non-toleranced dimensions.
4. Foot length is measured at gauge plane 0.25 mm above seating plane.

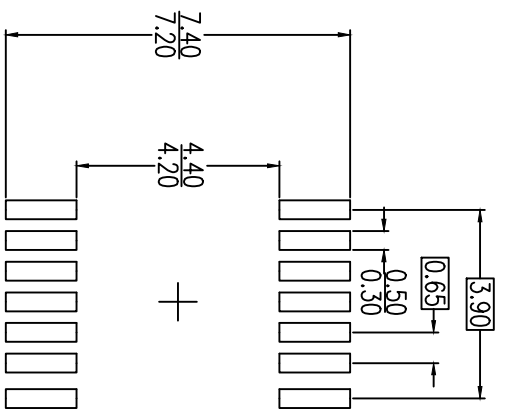

LAND PATTERN DIMENSIONS

NOTE:

1. ALL DIMENSIONS ARE IN MILLIMETERS

| Package Revision History | | |
|--------------------------|---------|--------------------|
| Date Created | Rev No. | Description |
| Mar, 10 2017 | Rev 01 | Added Land Pattern |
| Dec, 19 2017 | Rev 02 | New Format |

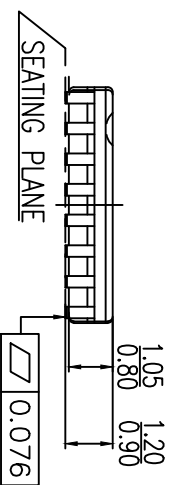
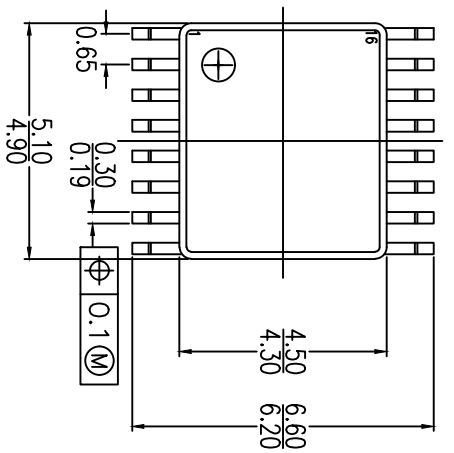

NOTE:
1. ALL DIMENSIONS ARE IN MILLIMETERS

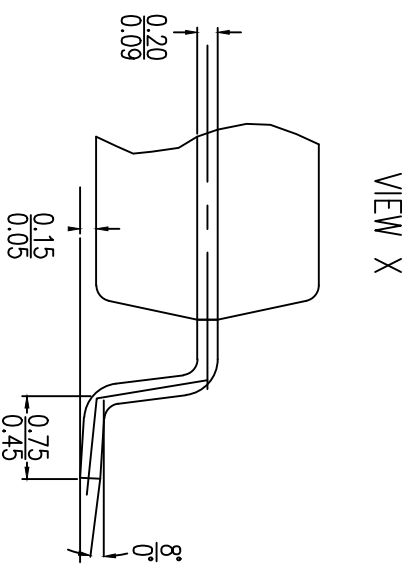

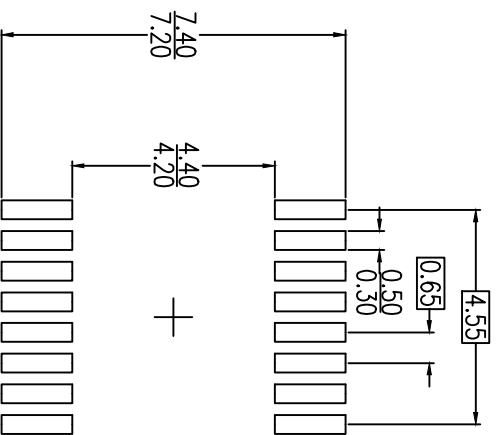

LAND PATTERN DIMENSIONS

NOTE:
1. ALL DIMENSIONS ARE IN MILLIMETERS

| Package Revision History | | |
|--------------------------|---------|--------------------------------|
| Date Created | Rev No. | Description |
| Jan 26, 2018 | Rev 00 | Revised from PSC-4056-02 PGG16 |

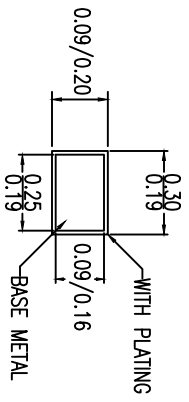
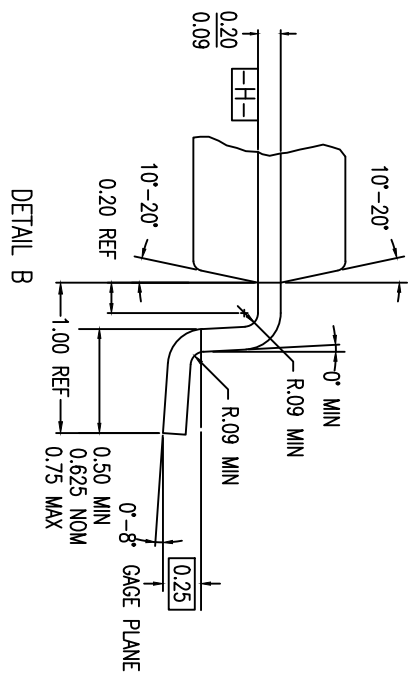
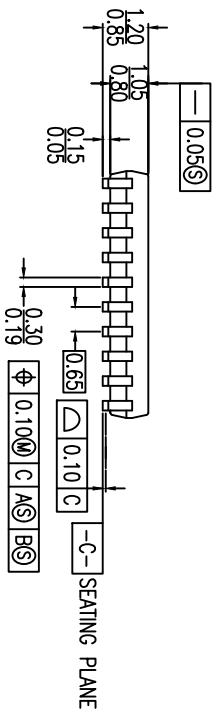
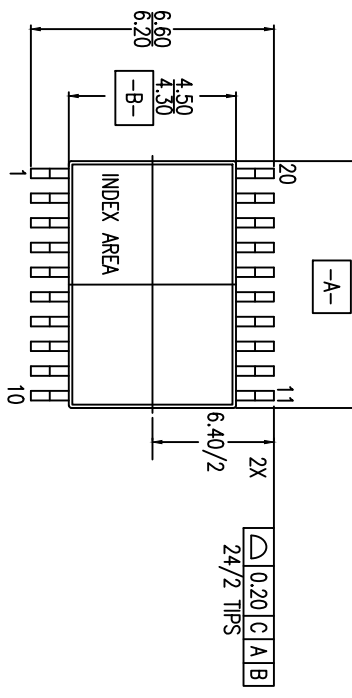

- NOTES:
1. ALL DIMENSIONING AND TOLERANCING CONFORM TO ANSI Y14.5M-1982
 2. ALL DIMENSION ARE IN MM.

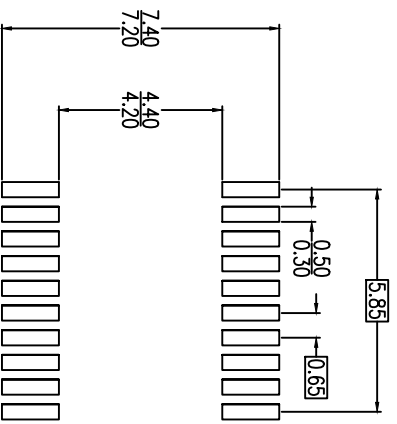

RECOMMENDED LAND PATTERN DIMENSIONS

NOTES:
 1. ALL DIMENSIONS ARE IN MILLIMETERS

| Package Revision History | | |
|--------------------------|---------|-----------------|
| Date Created | Rev No. | Description |
| July 24, 2018 | Rev 00 | Initial Release |

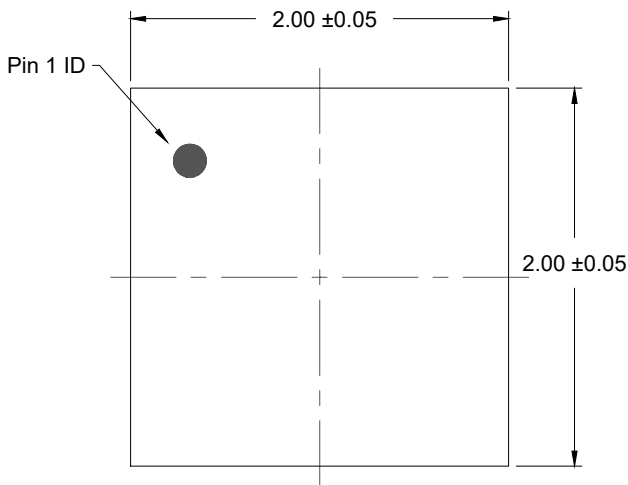

TOP VIEW

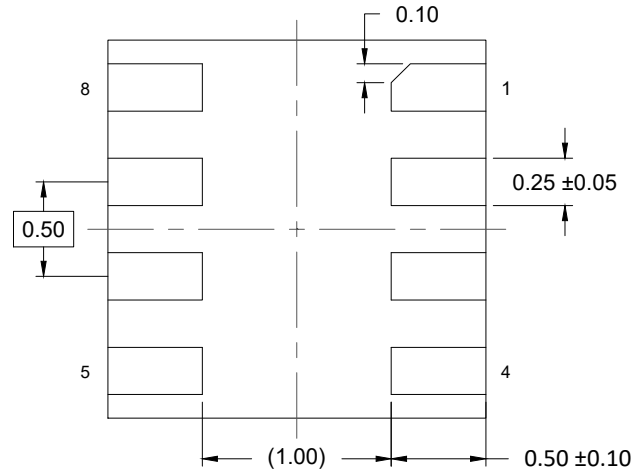

BOTTOM VIEW

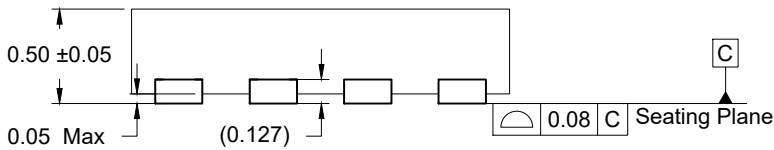

SIDE VIEW

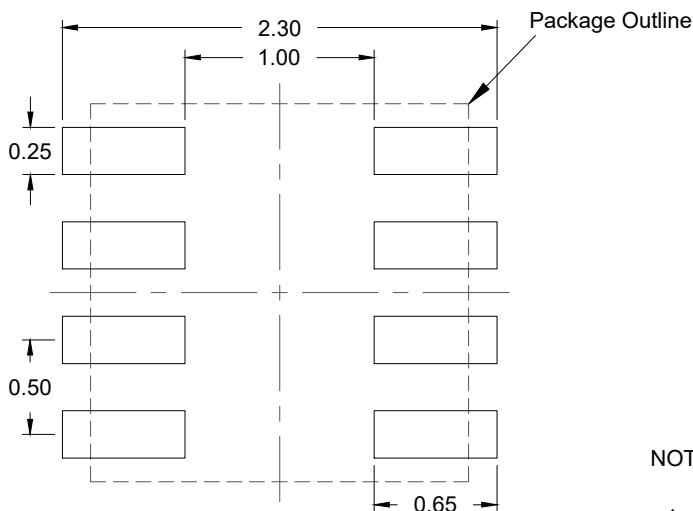

RECOMMENDED LAND PATTERN
(PCB Top View, NSMD Design)

NOTES:

1. JEDEC compatible.
2. All dimensions are in mm and angles are in degrees.
3. Use ± 0.05 mm for the non-toleranced dimensions.
4. Numbers in () are for references only.

| DATE CREATED | REV |
|--------------|-----|
| 4/3/14 | 00 |
| 12/11/14 | 01 |
| 4/5/18 | 02 |

NOE: REFER TO DCP FOR OFFICIAL CHANGE QFN TO

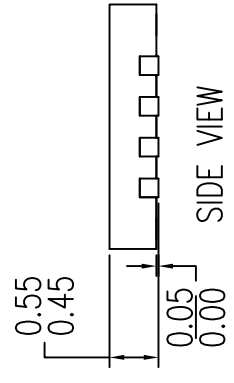
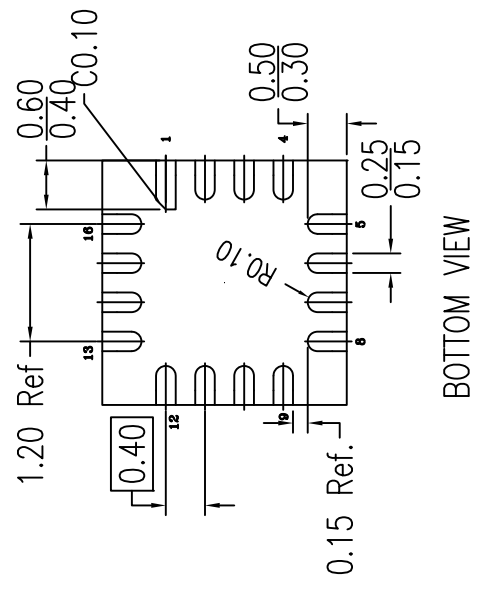
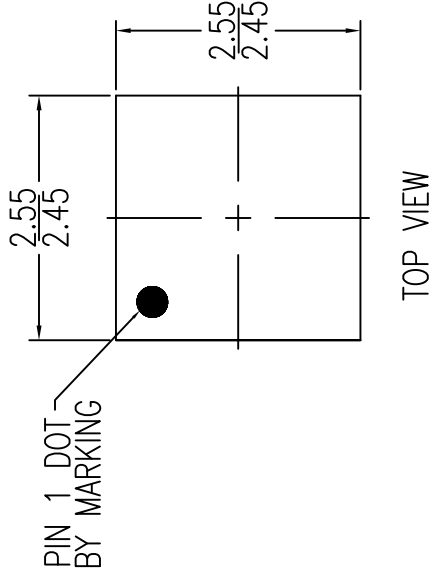

NOTES:

1. ALL DIMENSIONING AND TOLERANCING CONFORM TO ANSI Y14.5M-1982
2. ALL DIMENSIONS ARE IN MILLIMETERS.

| | | |
|--|--------|-------|
| TOLERANCES UNLESS SPECIFIED DECIMAL X± ANGULAR ±1° XXX± XXX± | WW | TITLE |
| | DRAWN | |
| | SIZE C | DO NO |

| DATE CREATED | REV |
|--------------|-----|
| 4/3/14 | 00 |
| 12/11/14 | 01 |
| 4/5/18 | 02 |

| IN | ADD | CHANGE QFN TO |
|----|-----|---------------|
| | | |

NOE: REFER TO DCP FOR OFFICIAL

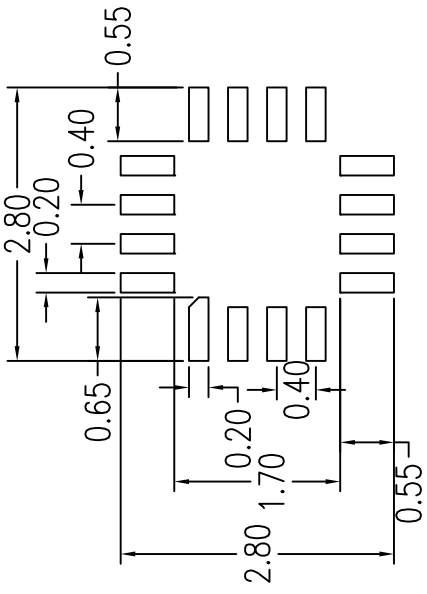

RECOMMENDED LAND PATTERN DIMENSION

NOTES:

1. ALL DIMENSIONS ARE IN MM. ANGLES IN DEGREES.
2. TOP DOWN VIEW AS VIEWED ON PCB.
3. LAND PATTERN RECOMMENDATION PER IPC-7351B GENERIC REQUIREMENT FOR SURFACE MOUNT DESIGN AND LAND PATTERN.

| | | | |
|---|----------------|--|-------|
| TOLERANCES UNLESS SPECIFIED DECIMAL XX± XXX± XXXX± | ANGULAR ±1° |  | WW |
| | | TITLE | DO NO |
| DRAWN | SIZE C | DO NO | DO NO |

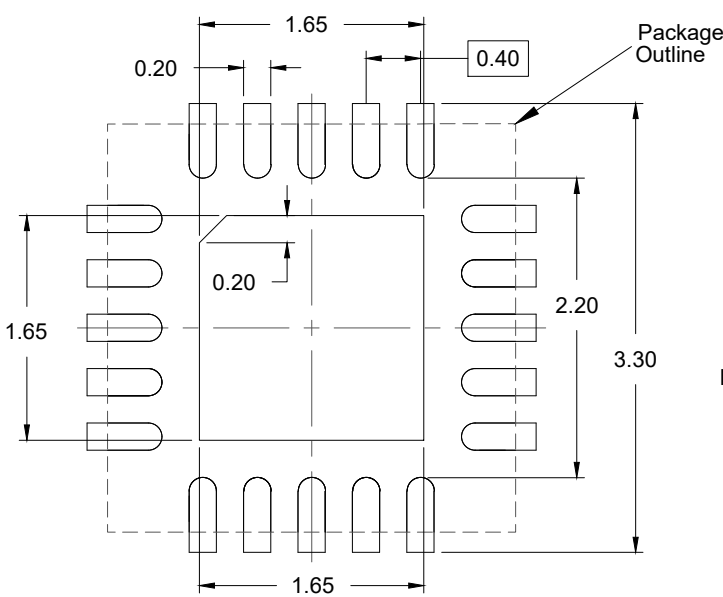
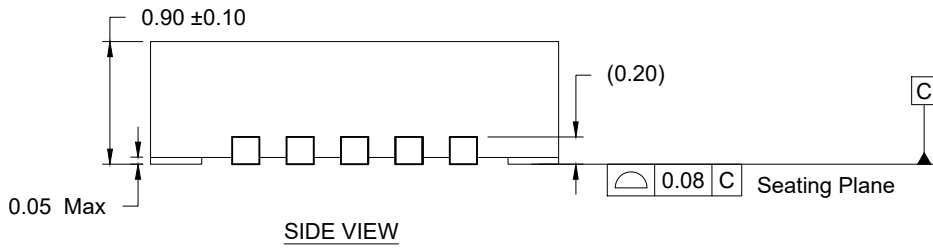
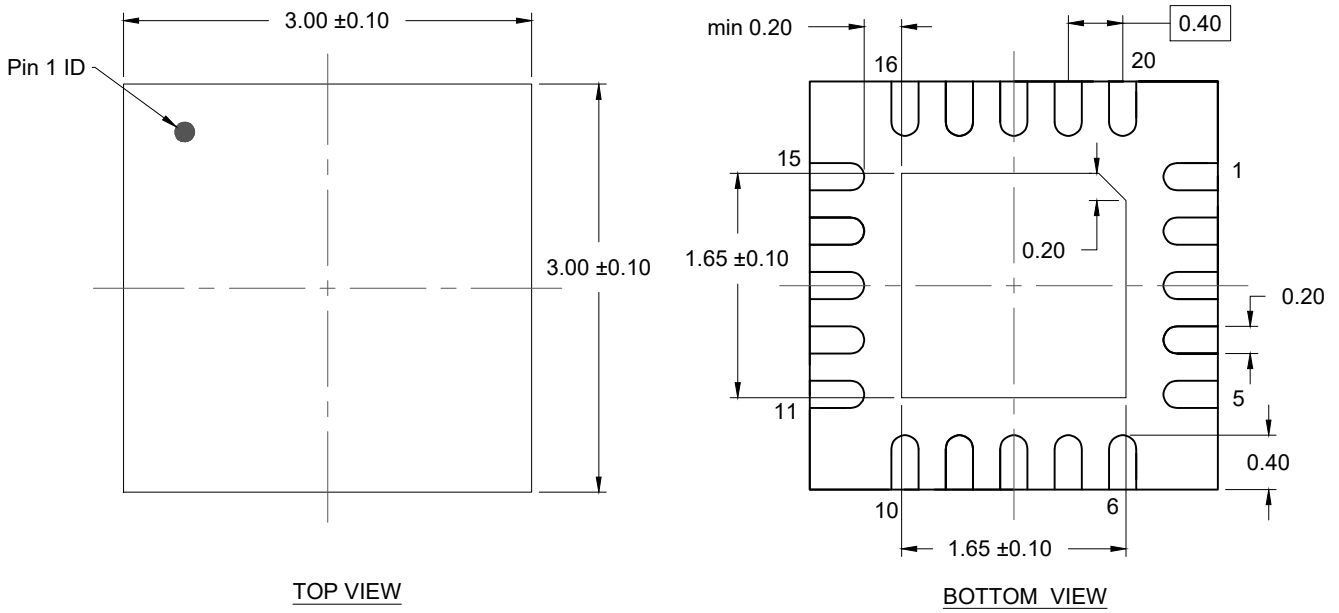

- NOTES:
1. JEDEC compatible.
 2. All dimensions are in mm and angles are in degrees.
 3. Use ± 0.05 mm for the non-toleranced dimensions.
 4. Numbers in () are for references only.

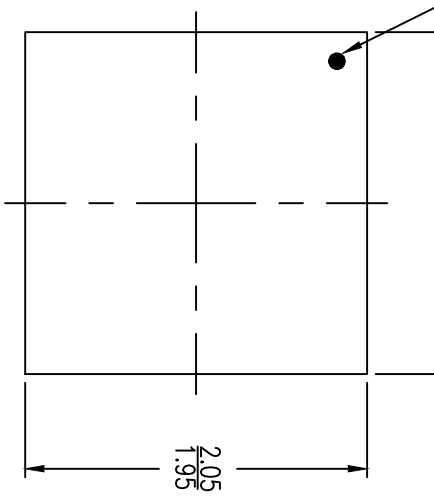

TOP VIEW

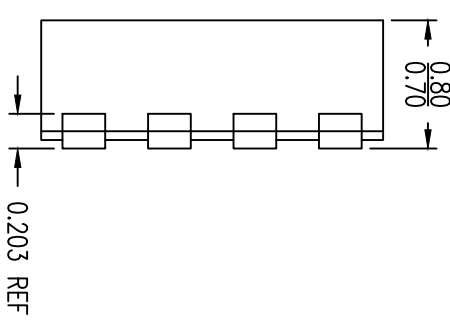

SIDE VIEW

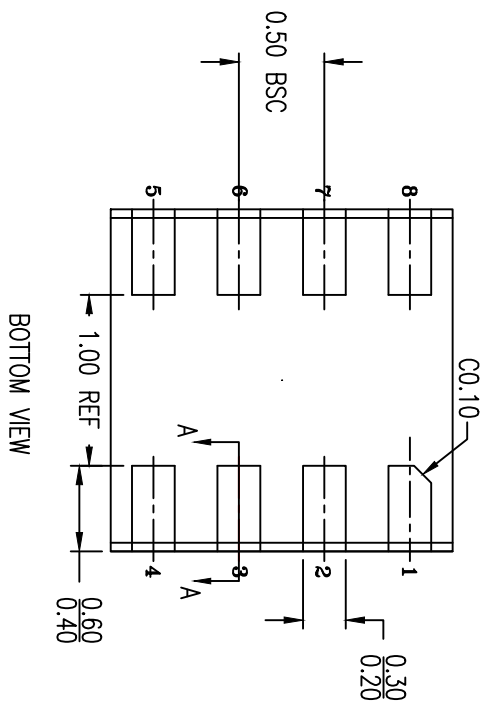

BOTTOM VIEW

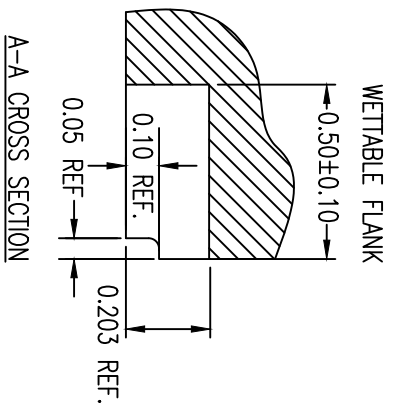

A-A CROSS SECTION

- NOTES:
1. ALL DIMENSIONING AND TOLERANCING CONFORM TO ANSI Y14.5M-1982
 2. ALL DIMENSIONS ARE IN MILLIMETERS

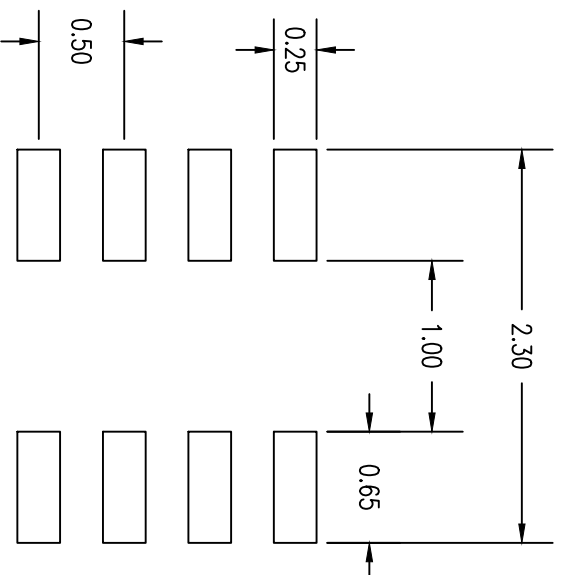

RECOMMENDED LAND PATTERN DIMENSION

NOTES:

1. ALL DIMENSION ARE IN MM. ANGLES IN DEGREES.
2. TOP DOWN VIEW, AS VIEWED.
3. LAND PATTERN RECOMMENDATION PER IPC-7351B GENERIC REQUIREMENT FOR MOUNT DESIGN AND LAND PATTERN.

| Package Revision History | | |
|--------------------------|---------|-----------------|
| Date Created | Rev No. | Description |
| Oct 23, 2018 | Rev 00 | Initial Release |

IMPORTANT NOTICE AND DISCLAIMER

RENESAS ELECTRONICS CORPORATION AND ITS SUBSIDIARIES (“RENESAS”) PROVIDES TECHNICAL SPECIFICATIONS AND RELIABILITY DATA (INCLUDING DATASHEETS), DESIGN RESOURCES (INCLUDING REFERENCE DESIGNS), APPLICATION OR OTHER DESIGN ADVICE, WEB TOOLS, SAFETY INFORMATION, AND OTHER RESOURCES “AS IS” AND WITH ALL FAULTS, AND DISCLAIMS ALL WARRANTIES, EXPRESS OR IMPLIED, INCLUDING, WITHOUT LIMITATION, ANY IMPLIED WARRANTIES OF MERCHANTABILITY, FITNESS FOR A PARTICULAR PURPOSE, OR NON-INFRINGEMENT OF THIRD-PARTY INTELLECTUAL PROPERTY RIGHTS.

These resources are intended for developers who are designing with Renesas products. You are solely responsible for (1) selecting the appropriate products for your application, (2) designing, validating, and testing your application, and (3) ensuring your application meets applicable standards, and any other safety, security, or other requirements. These resources are subject to change without notice. Renesas grants you permission to use these resources only to develop an application that uses Renesas products. Other reproduction or use of these resources is strictly prohibited. No license is granted to any other Renesas intellectual property or to any third-party intellectual property. Renesas disclaims responsibility for, and you will fully indemnify Renesas and its representatives against, any claims, damages, costs, losses, or liabilities arising from your use of these resources. Renesas' products are provided only subject to Renesas' Terms and Conditions of Sale or other applicable terms agreed to in writing. No use of any Renesas resources expands or otherwise alters any applicable warranties or warranty disclaimers for these products.

(Disclaimer Rev.1.01 Jan 2024)

Corporate Headquarters

TOYOSU FORESIA, 3-2-24 Toyosu,
Koto-ku, Tokyo 135-0061, Japan
www.renesas.com

Trademarks

Renesas and the Renesas logo are trademarks of Renesas Electronics Corporation. All trademarks and registered trademarks are the property of their respective owners.

Contact Information

For further information on a product, technology, the most up-to-date version of a document, or your nearest sales office, please visit www.renesas.com/contact-us/.

Looking for pricing, stock, or lifecycle information?

Click below to explore more details on WIN SOURCE:

-  [View 5PB1102CMGI8 on WIN SOURCE](#)
-  [Renesas Electronics America](#) Information

Optimize Your Supply Chain with WIN SOURCE Solutions

-  Global Sourcing Solution
-  Obsolete Management
-  Cost Control Management
-  Shortage Management
-  Alternative Solution
-  Excess Inventory Management