



THE DATASHEET OF DAC1221E G4





DAC1221

For most current data sheet and other product information, visit www.burr-brown.com

16-Bit Low Power DIGITAL-TO-ANALOG CONVERTER

FEATURES

- 16-BIT MONOTONICITY GUARANTEED OVER -40°C TO $+85^{\circ}\text{C}$
- LOW POWER: 1.2mW
- VOLTAGE OUTPUT
- SETTLING TIME: 2ms to 0.012%
- MAX LINEARITY ERROR: 30ppm
- ON-CHIP CALIBRATION

APPLICATIONS

- PROCESS CONTROL
- ATE PIN ELECTRONICS
- CLOSED-LOOP SERVO-CONTROL
- SMART TRANSMITTERS
- PORTABLE INSTRUMENTS
- VCO CONTROL

DESCRIPTION

The DAC1221 is a Digital-to-Analog (D/A) converter offering 16-bit monotonic performance over the specified temperature range. It utilizes delta-sigma technology to achieve inherently linear performance in a small package at very low power. The output range is two times the external reference voltage. On-chip calibration circuitry dramatically reduces offset and gain errors.

The DAC1221 features a synchronous serial interface. In single converter applications, the serial interface can be accomplished with just two wires, allowing low-cost isolation. For multiple converters, a $\overline{\text{CS}}$ signal allows for selection of the appropriate D/A converter.

The DAC1221 has been designed for closed-loop control applications in the industrial process control market, and high resolution applications in the test and measurement market. It is also ideal for remote applications, battery-powered instruments, and isolated systems. The DAC1221 is available in a SSOP-16 package.

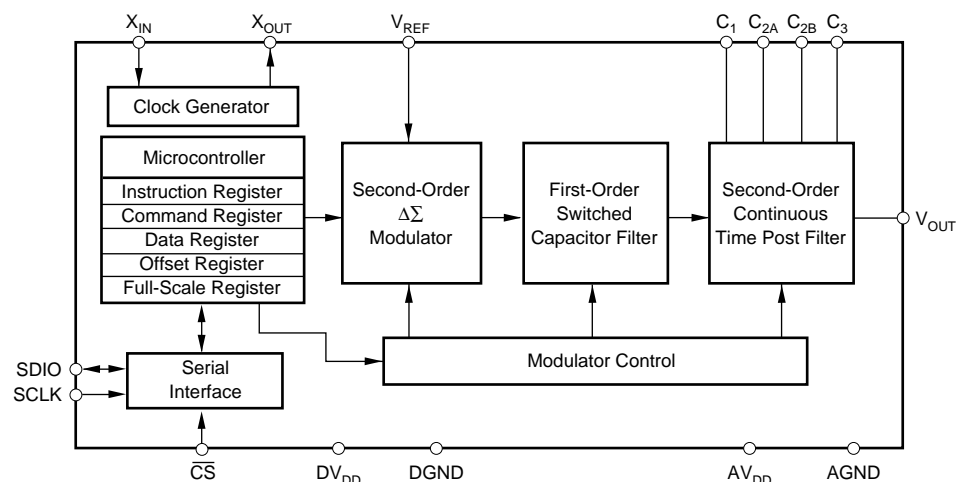

International Airport Industrial Park • Mailing Address: PO Box 11400, Tucson, AZ 85734 • Street Address: 6730 S. Tucson Blvd., Tucson, AZ 85706 • Tel: (520) 746-1111
Twx: 910-952-1111 • Internet: <http://www.burr-brown.com/> • Cable: BBRCORP • Telex: 066-6491 • FAX: (520) 889-1510 • Immediate Product Info: (800) 548-6132

SPECIFICATIONS

All specifications T_{MIN} to T_{MAX} , $AV_{DD} = DV_{DD} = +3V$, $f_{XIN} = 2.5MHz$, $V_{REF} = +1.25V$, $C_1 = 2.2nF$, $C_2 = 150pF$, $C_3 = 6.8nF$, unless otherwise noted.

PARAMETER	CONDITIONS	DAC1221E			UNITS	
		MIN	TYP	MAX		
ACCURACY Monotonicity Linearity Error ⁽¹⁾ Offset Error ⁽²⁾ Offset Error Drift ⁽³⁾ Midscale Error ⁽²⁾ Midscale Error Drift ⁽³⁾ Gain Error ⁽²⁾ Gain Error Drift ⁽³⁾ Power-Supply Rejection Ratio	$V_{OUT} = 20mV$, CALPIN = 1 ⁽⁶⁾ $V_{OUT} = V_{REF}$, CALPIN = 1 ⁽⁶⁾ CALPIN = 1 ⁽⁶⁾ at DC, dB = $-20\log(\Delta V_{OUT}/\Delta V_{DD})$	16	50 ±20 50	±30 ±190 0.015	Bits ppm of FSR μV $\mu V/^\circ C$ μV $\mu V/^\circ C$ % ppm/°C dB	
ANALOG OUTPUT Output Voltage ⁽⁴⁾ Output Current ⁽¹⁾ Capacitive Load Short-Circuit Current Short-Circuit Duration	GND or V_{DD}	0	±10 Indefinite	$2 \cdot V_{REF}$ ± 0.25 500	V mA pF mA	
DYNAMIC PERFORMANCE Settling Time ^(1,5) Output-Noise Voltage	To ±0.012% 1Hz to 2kHz		1.8 45	2	ms μV_{rms}	
REFERENCE INPUT Input Voltage Input Impedance		1.125	1.25 1	1.375	V MΩ	
DIGITAL INPUT/OUTPUT Logic Family Logic Levels (all except X_{IN}) V_{IH} V_{IL} V_{OH} V_{OL} Input-Leakage Current X_{IN} Frequency Range (f_{XIN}) Data Format	$I_{OH} = -0.8mA$ $I_{OL} = 1.6mA$ User Programmable	TTL-Compatible CMOS			$DV_{DD} + 0.3$ 0.8 0.4 ± 10 2.5	V V V V μA MHz
POWER SUPPLY REQUIREMENTS Power-Supply Voltage Supply Current Analog Current Digital Current Power Dissipation	Normal Mode Sleep Mode	2.7	320 70 1.2 0.25	3.3 1.6	V μA μA mW mW	
TEMPERATURE RANGE Specified Performance		-40		+85	°C	

NOTES: (1) Valid from AGND + 20mV to $2 \cdot V_{REF}$. (2) Applies after calibration. (3) Recalibration can remove these errors. (4) Ideal output voltage. (5) Using external low-pass filter with 2kHz corner frequency. (6) See Command Register for description of CALPIN.

PIN CONFIGURATION

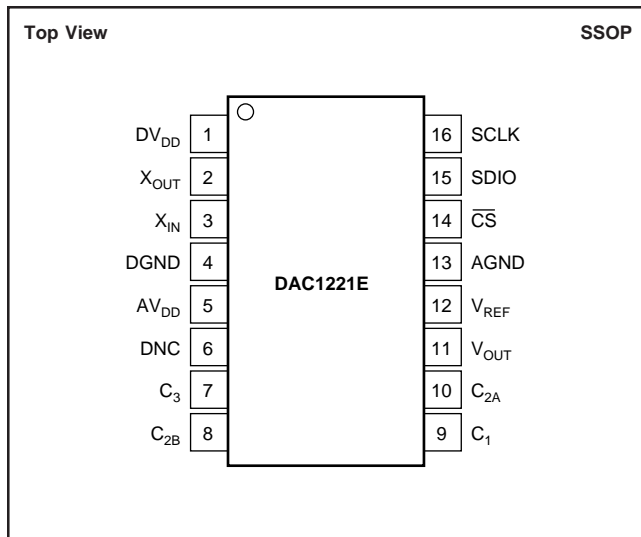

PIN DESCRIPTIONS

PIN	NAME	DESCRIPTION
1	DV _{DD}	Digital Supply, +3V nominal
2	X _{OUT}	Digital, System Clock Output
3	X _{IN}	Digital, System Clock Input
4	DGND	Digital Ground
5	AV _{DD}	Analog Supply, +3V nominal
6	DNC	Do Not Connect
7	C ₃	Analog, Filter Capacitor
8	C _{2B}	Analog, Filter Capacitor
9	C ₁	Analog, Filter Capacitor
10	C _{2A}	Analog, Filter Capacitor
11	V _{OUT}	Analog Output Voltage
12	V _{REF}	Analog, Reference Input
13	AGND	Analog Ground
14	\overline{CS}	Digital, Chip Select Input
15	SDIO	Digital, Serial Data Input/Output
16	SCLK	Digital, Clock Input for Serial Data Transfer

ABSOLUTE MAXIMUM RATINGS⁽¹⁾

AV _{DD} to DV _{DD}	±0.3V
AV _{DD} to AGND	-0.3V to 4V
DV _{DD} to DGND	-0.3V to 4V
AGND to DGND	±0.3V
V _{REF} Voltage to AGND	1.0V to 1.5V
Digital Input Voltage to DGND	-0.3V to DV _{DD} + 0.3V
Digital Output Voltage to DGND	-0.3V to DV _{DD} + 0.3V
Package Power Dissipation	(T _{JMAX} - T _A)/θ _{JA}
Maximum Junction Temperature (T _{JMAX})	+150°C
Thermal Resistance, θ _{JA}	
SSOP-16	200°C/W
Lead Temperature (soldering, 10s)	+300°C

NOTE: (1) Stresses above those listed under "Absolute Maximum Ratings" may cause permanent damage to the device. Exposure to absolute maximum conditions for extended periods may affect device reliability.



ELECTROSTATIC DISCHARGE SENSITIVITY

This integrated circuit can be damaged by ESD. Burr-Brown recommends that all integrated circuits be handled with appropriate precautions. Failure to observe proper handling and installation procedures can cause damage.

ESD damage can range from subtle performance degradation to complete device failure. Precision integrated circuits may be more susceptible to damage because very small parametric changes could cause the device not to meet its published specifications.

PACKAGE/ORDERING INFORMATION

PRODUCT	PACKAGE	PACKAGE DRAWING NUMBER	SPECIFIED TEMPERATURE RANGE	PACKAGE MARKING	ORDERING NUMBER ⁽¹⁾	TRANSPORT MEDIA
DAC1221E	SSOP-16	322	-40°C to +85°C	DAC1221E	DAC1221E	Rails
"	"	"	"	"	DAC1221E/2K5	Tape and Reel

NOTE: (1) Models with a slash (/) are available only in Tape and Reel in the quantities indicated (e.g., /2K5 indicates 2500 devices per reel). Ordering 2500 pieces of "DAC1221E/2K5" will get a single 2500-piece Tape and Reel.

The information provided herein is believed to be reliable; however, BURR-BROWN assumes no responsibility for inaccuracies or omissions. BURR-BROWN assumes no responsibility for the use of this information, and all use of such information shall be entirely at the user's own risk. Prices and specifications are subject to change without notice. No patent rights or licenses to any of the circuits described herein are implied or granted to any third party. BURR-BROWN does not authorize or warrant any BURR-BROWN product for use in life support devices and/or systems.

TYPICAL PERFORMANCE CURVES

At $T_A = +25^\circ\text{C}$, $AV_{DD} = DV_{DD} = +3.0\text{V}$, $f_{XIN} = 2.5\text{MHz}$, $V_{REF} = 1.25\text{V}$, $C_1 = 2.2\text{nF}$, $C_2 = 150\text{pF}$ and $C_3 = 6.8\text{nF}$.

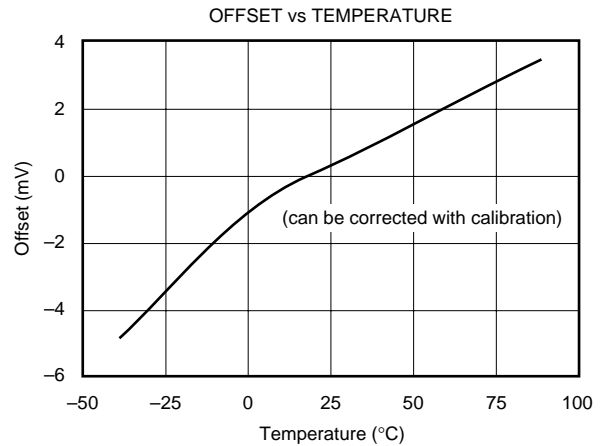
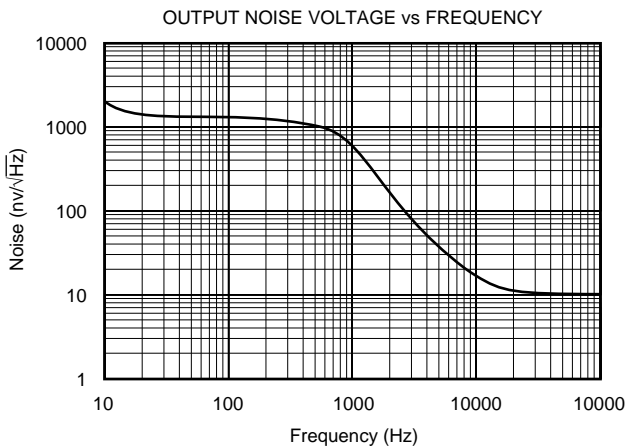
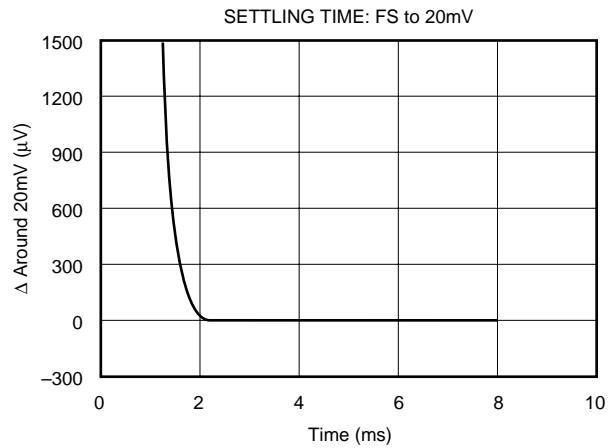
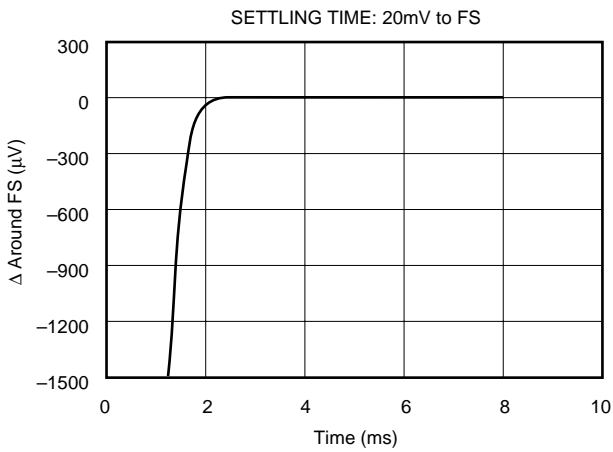
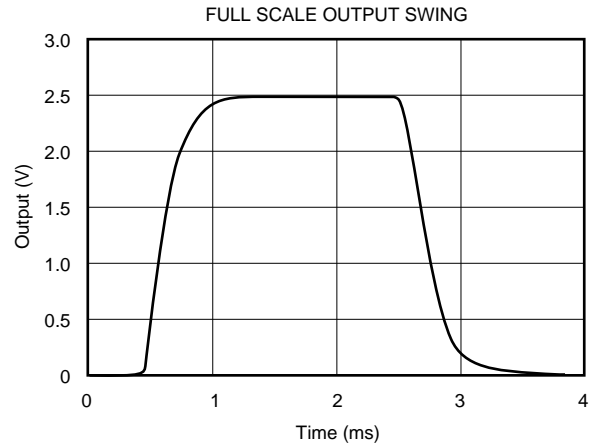
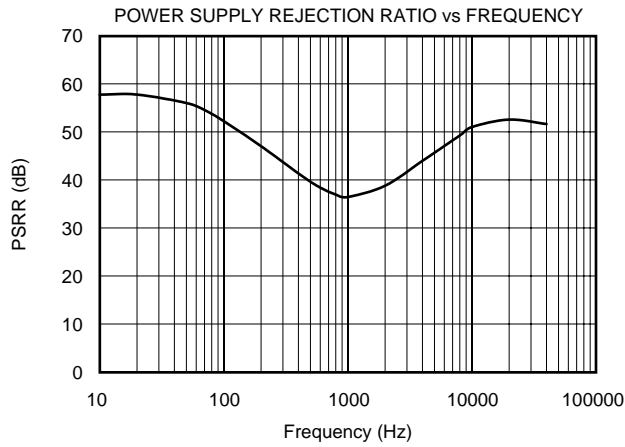

TYPICAL PERFORMANCE CURVES

At $T_A = +25^\circ\text{C}$, $AV_{DD} = DV_{DD} = +3.0\text{V}$, $f_{XIN} = 2.5\text{MHz}$, $V_{REF} = 1.25\text{V}$, $C_1 = 2.2\text{nF}$, $C_2 = 150\text{pF}$ and $C_3 = 6.8\text{nF}$.

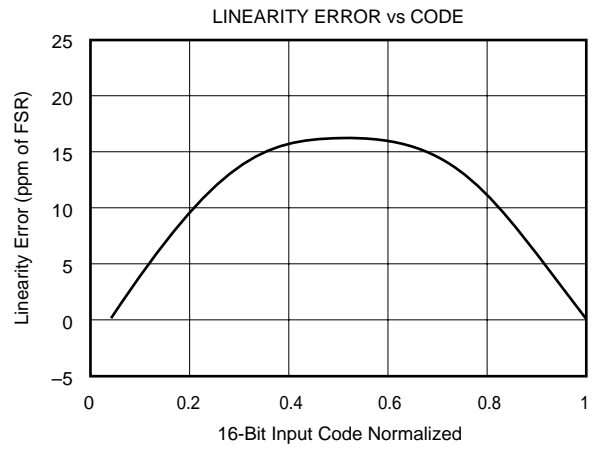
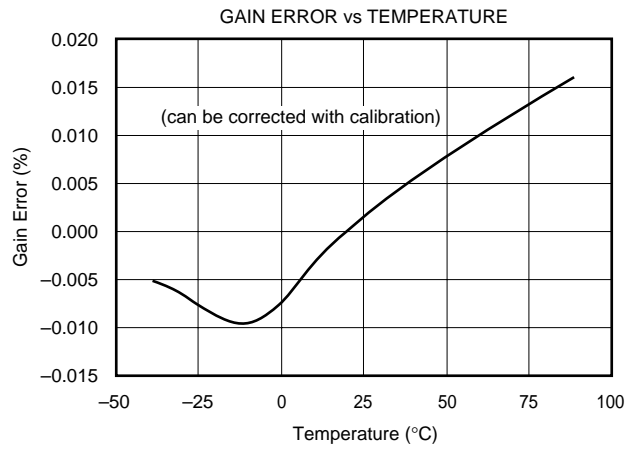

THEORY OF OPERATION

The DAC1221 is a precision, high dynamic range, self-calibrating, 16-bit, delta-sigma digital-to-analog converter. It contains a second-order delta-sigma modulator, a first-order switched-capacitor filter, a second-order continuous-time post filter, a microcontroller including the Instruction, Command and Calibration registers, a serial interface, and a clock generator circuit.

The design topology provides low system noise and good power-supply rejection. The modulator frequency of the delta-sigma D/A converter is controlled by the system clock.

The DAC1221 also includes complete onboard calibration that can correct for internal offset and gain errors. The calibration registers are fully readable and writable. This feature allows for system calibration. The various settings, modes, and registers of the DAC1221 are read or written via a synchronous serial interface. This interface operates as an externally clocked interface.

DEFINITION OF TERMS

Differential Nonlinearity Error—The differential nonlinearity error is the difference between an actual step width and the ideal value of 1 LSB. If the step width is exactly 1 LSB, the differential nonlinearity error is zero. A differential nonlinearity specification of less than 1 LSB guarantees monotonicity.

Drift—The drift is the change in a parameter over temperature.

Full-Scale Range (FSR)—This is the magnitude of the typical analog output voltage range which is $2 \cdot V_{REF}$. For example, when the converter is configured with a 1.25V reference, the full-scale range is 2.5V.

Gain Error—This error represents the difference in the slope between the actual and ideal transfer functions.

Linearity Error—The linearity error is the deviation of the actual transfer function from an ideal straight line between the data end points.

Least Significant Bit (LSB) Weight—This is the ideal change in voltage that the analog output will change with a change in the digital input code of 1 LSB.

Monotonicity—Monotonicity assures that the analog output will increase or stay the same for increasing digital input codes.

Offset Error—The offset error is the difference between the expected and actual output, when the output is zero. The value is calculated from measurements made when $V_{OUT} = 20mV$.

Settling Time—The settling time is the time it takes the output to settle to its new value after the digital code has been changed.

f_{XIN} —The frequency of the crystal oscillator or CMOS-compatible input signal at the X_{IN} input of the DAC1221.

ANALOG OPERATION

The system clock is divided down to provide the sample clock for the modulator. The sample clock is used by the modulator to convert the multi-bit digital input into a 1-bit digital output stream. The use of a 1-bit DAC provides inherent linearity. The digital output stream is then converted into an analog signal via the 1-bit DAC and then filtered by the 1st-order switched-capacitor filter.

The output of the switched-capacitor filter feeds into the continuous time filter. The continuous time filter uses external capacitors, C_1 and C_2 , to adjust the settling time. The connections for capacitors are shown in Figure 1. C_1 connects to V_{REF} . C_2 connects between the C_2 pins. C_3 is connected between C_3 and V_{REF} , and is used for calibration.

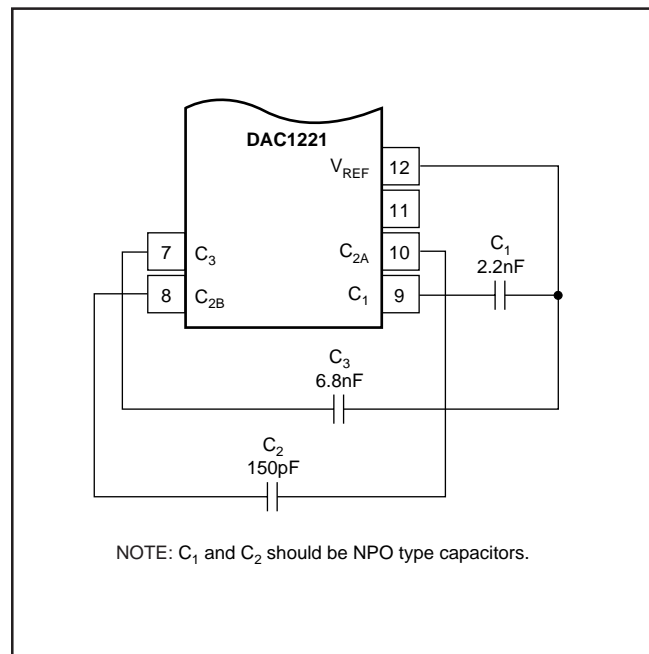

FIGURE 1. Capacitor Connections.

CALIBRATION

The DAC1221 offers a self-calibration mode which automatically calibrates the output offset and gain. The calibration is performed once and then normal operation is resumed. In general, calibration is recommended immediately after power-on and whenever there is a “significant” change in the operating environment. The amount of change which should cause re-calibration is dependent on the application. Where high accuracy is important, re-calibration should be done on changes in temperature and power supply.

After a calibration has been accomplished, the Offset Calibration Register (OCR) and the Full-Scale Calibration Register (FCR) contain the results of the calibration.

Note that the values in the calibration registers will vary from configuration to configuration and from part to part.

Self Calibration

A self-calibration is performed after the bits “01” have been written to the Command Register Operation Mode bits (MD1 and MD0). This initiates a self-calibration on the next clock cycle. The offset correction code is determined by a repeated sequence of auto-zeroing the calibration comparator to the offset reference and then comparing the DAC output to the offset reference value. The end result is the averaged, Offset Two’s Complement adjusted, and placed in the OCR. The gain correction is done in a similar fashion, except the correction is done against V_{REF} to eliminate common-mode errors. The FCR result represents the gain code and is not Offset Two’s Complement adjusted.

The calibration function takes between 300ms and 500ms (for $f_{XIN} = 2.5\text{MHz}$) to complete. Once calibration is initiated, further writing of register bits is disabled until calibration completes. The status of calibration can be verified by reading the status of the Command Register Operation Mode bits (MD1 and MD0). These bits will return to normal mode “00” when calibration is complete.

It is recommended that the output be connected during calibration. The output isolation is controlled by the CALPIN bit in the CMR register. Setting the CALPIN bit will connect the output and clearing the bit will disconnect and isolate the output. Although it is recommended to connect the output during calibration, the load impedance should be such that the DAC1221 is not required to sink any current, but is able to source up to the specified maximum.

Output Mode

The output of the DAC1221 can be synchronously reset. By setting the CLR bit in the CMR, the data input register is cleared to zero. This will result in an output of 0V when $DF = 1$, or V_{REF} when $DF = 0$.

The settling time is determined by the DISF and ADPT bits of the command register. The default state of $DISF = 0$ and $ADPT = 0$ enables fast settling, unless the output step is small ($\approx 40\text{mV}$). However, the DAC1221 can be forced to always use fast settling if the ADPT bit is set to 1. If DISF is set to 1, all fast settling is disabled.

The CRST bit of the CMR can be used to reset the offset and calibration registers. By setting the CRST bit, the contents of the calibration registers are reset to 0.

REFERENCE INPUT

The reference input voltage of 1.25V can be directly connected to V_{REF} pin.

The recommended reference circuit for the DAC1221 is shown in Figure 2.

DIGITAL OPERATION

SYSTEM CONFIGURATION

The DAC1221 is controlled by 8-bit instruction codes (INSR) and 16-bit command codes (CMR) via the serial interface, which is externally clocked.

The DAC1221 Microcontroller (MC) consists of an ALU and a register bank. The MC has three states: power-on reset, calibration, and normal operation. In the power-on reset state, the MC resets all the registers to their default states. In the calibration state, the MC performs offset and gain self-calibration. In the normal state, the MC performs D/A conversions.

The DAC1221 has five internal registers, as shown in Table I. Two of these, the Instruction Register (INSR) and the Command Register (CMR), control the operation of the converter. The Instruction Register utilizes an 8-bit instruction code to control the serial interface to determine whether the next operation is either a read or a write, to control the word length, and to select the appropriate register to read/write. Communication with the DAC1221 is controlled via the INSR. Under normal operation, the INSR is written as the first part of each serial communication. The instruction that is sent determines what type of communication will occur next. It is not possible to read the INSR. The Command Register has a 16-bit command code to set up the

INSR	Instruction Register	8 Bits
DIR	Data Input Register	16 Bits
CMR	Command Register	16 Bits
OCR	Offset Calibration Register	24 Bits
FCR	Full-Scale Calibration Register	24 Bits

TABLE I. DAC1221 Registers.

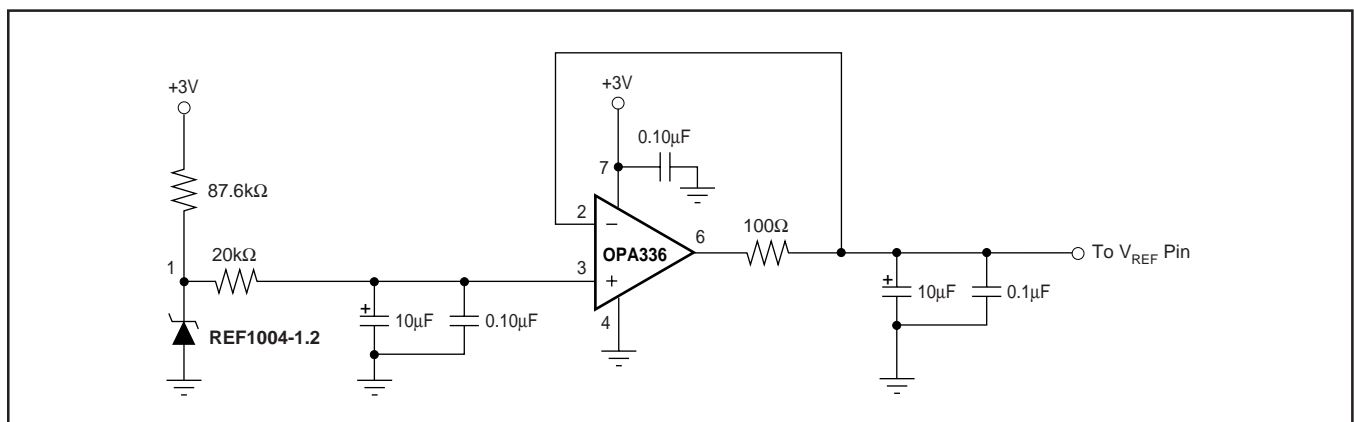

FIGURE 2. Recommended External Voltage Reference Circuit for Best Low Noise Operation with the DAC1221.

DAC1221 operation mode, settling mode and data format. The Data Input Register (DIR) contains the value for the next conversion. The Offset and Full-Scale Calibration Registers (OCR and FCR) contain data used for correcting the internal conversion value after it is placed into the DIR. The data in these two registers may be the result of a calibration routine, or they may be values which have been written directly via the serial interface.

INSTRUCTION REGISTER (INSR)

Each serial communication starts with the 8 bits of INSR being sent to the DAC1221. The read/write bit, the number of bytes (n), and the starting register address are defined in Table II. When the n bytes have been transferred, the instruction is complete. A new communication cycle is initiated by sending a new INSR (under restrictions outlined in the Interfacing section).

MSB				LSB			
R/W	MB1	MB0	0	A3	A3	A1	A0

NOTE: INSR is a write-only register with the MSB (Most Significant Byte and Bit) written first, independent of the BD bit.

TABLE II. Instruction Register.

R/W (Read/Write) Bit—For a write operation to occur, this bit of the INSR must be 0. For a read, this bit must be 1, as shown:

R/W	
0	Write
1	Read

MB1, MB0 (Multiple Bytes) Bits—These two bits are used to control the word length (number of bytes) of the read or write operation, as shown:

MB1	MB0	
0	0	1 Byte
0	1	2 Bytes
1	0	3 Bytes

A3 – A0 (Address) Bits—These four bits select the beginning register location that will be read from or written to, as shown in Table III. Each subsequent byte will be read from or written to the next higher location (increment address). If the BD bit in the Command register is set, each subsequent byte will be read from or written to the next lower location (decrement address). This bit does not affect INSR register

or the write operation for the CMR register. If the next location is reserved in Table III, the results are unknown. Reading or writing continues until the number of bytes specified by MB1 and MB0 have been transferred.

A3	A2	A1	A0	
0	0	0	0	Data Input Register Byte 1 MSB
0	0	0	1	Data Input Register Byte 0 LSB
0	0	1	0	Reserved
0	0	1	1	Reserved
0	1	0	0	Command Register Byte 1 MSB
0	1	0	1	Command Register Byte 0 LSB
0	1	1	0	Reserved
0	1	1	1	Reserved
1	0	0	0	Offset Cal Register Byte 2 MSB
1	0	0	1	Offset Cal Register Byte 1
1	0	1	0	Offset Cal Register Byte 0 LSB
1	0	1	1	Reserved
1	1	0	0	Full-Scale Cal Register Byte 2 MSB
1	1	0	1	Full-Scale Cal Register Byte 1
1	1	1	0	Full-Scale Cal Register Byte 0 LSB
1	1	1	1	Reserved

TABLE III. A3 - A0 Addressing.

COMMAND REGISTER (CMR)

The CMR controls all of the functionality of the DAC1221. The new configuration is latched in on the negative transition of SCLK for the last bit of the last byte of data being written to the command register. The organization of the CMR is comprised of 16 bits of information in 2 bytes of 8 bits each.

MSB				Byte 1			
ADPT	CALPIN	1	0	1	0	CRST	0
Byte 0				LSB			
0	CLR	DF	DISF	BD	MSB	MD1	MD0

TABLE IV. Command Register.

ADPT (Adaptive Filter Disable) Bit—The ADPT bit determines if the adaptive filter is enabled or disabled. When the Adaptive Filter is enabled, the DAC1221 does fast settling only when there is an output step of larger than $\approx 40\text{mV}$. For small changes in the data, fast settling is not necessary. When ADPT = 1, the Adaptive Filter is disabled and the DAC1221 will not look at the size of a step to determine the necessity of using fast settling. In either case, fast settling can be defeated if DISF = 1.

ADPT	
0	Enabled (default)
1	Disabled

CALPIN (Calibration Pin) Bit—The CALPIN bit determines if the output is isolated or connected during calibration.

CALPIN	
0	Output Isolated (default)
1	Output Connected

CRST (Calibration Reset) Bit—The CRST bit resets the offset and full-scale calibration registers, as shown:

CRST	
0	OFF (default)
1	Reset

CLR (Clear) Bit—The CLR bit synchronously resets the data input register to zero. The analog output will be based on the DF bit—if 1, the output will be 0V; if 0, the output will be V_{REF} .

DF (Data Format) Bit—The DF bit controls the format of the input data, shown in hexadecimal (either Offset Two's Complement or Straight Binary), as shown:

Input Code		V_{OUT}
Offset Two's Complement DF = 0 (default)	Straight Binary DF = 1	
8000	0000	0
0000	8000	V_{REF}
7FFF	FFFF	$2 \cdot V_{REF}$

DISF (Disable Fast Settling) Bit—The DISF bit disables the fast settling option. If this bit is zero the fast settling performance is determined by the ADPT bit.

DISF	
0	Fast Settling (default)
1	Disable Fast Settling

BD (Byte Order) Bit—The BD bit controls the order in which bytes of data are transferred (either most significant byte first (MSBF) or least significant byte first (LSBF)), as shown:

BD bit:	0 (default)	1	0 (default)	1
<i>register</i>	read		write	
INSR	write only	write only	MSBF	MSBF
CMR	MSBF	LSBF	MSBF	MSBF
DIR	MSBF	LSBF	MSBF	LSBF
OCR	MSBF	LSBF	MSBF	LSBF
FCR	MSBF	LSBF	MSBF	LSBF

Care must be observed in reading the Command Register if the state of the BD bit is unknown. If a two byte read is started at address 0100 with BD = 0, it will read 0100, then 0101. However, if BD = 1, it will read 0100, then 0011. If the BD bit is unknown, all reads of the command register are best performed as read commands of one byte.

MSB (Bit Order) Bit—The MSB bit controls the order in which bits within a byte of data are read or written (either most significant bit first or least significant bit first), as follows:

MSB	
0	MSB First (default)
1	LSB First

MD1 – MD0 (Operating Mode) Bits—The Operating Mode bits control the calibration functions of the DAC1221. The Normal Mode is used to perform conversions. The Self-Calibration Mode is a one-step calibration sequence that calibrates both the offset and full scale.

MD1	MD0	
0	0	Normal Mode
0	1	Self-Cal
1	0	Sleep (default)
1	1	Reserved

Offset Calibration Register (OCR)

The OCR is a 24-bit register containing the offset correction factor that is used to apply a correction to the digital input before it is transferred to the modulator. The results of the self-calibration process will be written to this register.

The OCR is both readable and writable via the serial interface. For applications requiring a more accurate calibration, a calibration can be performed, the results averaged, and a more precise offset calibration value written back to the OCR.

The actual OCR value will change from part to part and with configuration, temperature, and power supply.

In addition, be aware that the contents of the OCR are not used to directly correct the digital input. Rather, the correction is a function of the OCR value. This function is linear and two known points can be used as a basis for interpolating intermediate values for the OCR.

The results of calibration are averaged, Offset Two's Complement adjusted, and placed in the OCR.

MSB		Byte 2					
OCR23	OCR22	OCR21	OCR20	OCR19	OCR18	OCR17	OCR16
		Byte 1					
OCR15	OCR14	OCR13	OCR12	OCR11	OCR10	OCR9	OCR8
		Byte 0				LSB	
OCR7	OCR6	OCR5	OCR4	OCR3	OCR2	OCR1	OCR0

TABLE V. Offset Calibration Register.

Full-Scale Calibration Register (FCR)

The FCR is a 24-bit register which contains the full-scale correction factor that is applied to the digital input before it is transferred to the modulator. The contents of this register will be the result of a self-calibration, or written to by the user.

The FCR is both readable and writable via the serial interface. For applications requiring a more accurate calibration, a calibration can be performed, the results averaged, and a more precise value written back to the FCR.

The actual FCR value will change from part to part and with configuration, temperature, and power supply.

In addition, be aware that the contents of the FCR are not used to directly correct the digital input. Rather, the correction is a function of the FCR value. This function is linear and two known points can be used as a basis of interpolating intermediate values for the FCR. The contents of the FCR are in unsigned binary format. This is not affected by the DF bit in the Command Register.

MSB				Byte 2				
FCR23	FCR22	FCR21	FCR20	FCR19	FCR18	FCR17	FCR16	
				Byte 1				
FCR15	FCR14	FCR13	FCR12	FCR11	FCR10	FCR9	FCR8	
				Byte 0				LSB
FCR7	FCR6	FCR5	FCR4	FCR3	FCR2	FCR1	FCR0	

TABLE VI. Full-Scale Calibration Register.

Data Input Register (DIR)

The DIR is a 16-bit register which contains the digital input value (see Table VII). The register is latched on the falling edge of the last bit of the last byte sent. The contents of the DIR are then loaded into the modulator. This means that the DIR register can be updated after sending 1 or 2 bytes, which is determined by the MB1 and MB0 bits in the Instruction Register. The contents of the DIR can be Offset Two's Complement or Straight Binary.

MSB				Byte 1				
DIR15	DIR14	DIR13	DIR12	DIR11	DIR10	DIR9	DIR8	
				Byte 0				LSB
DIR7	DIR6	DIR5	DIR4	DIR3	DIR2	DIR1	DIR0	

TABLE VII. Data Input Register.

SLEEP MODE

The Sleep Mode is entered after the bit combination 10 has been written to the CMR Operation Mode bits (MD1 and MD0). This mode ends when these bits are changed to a value other than 10.

Communication with the DAC1221 can continue during Sleep Mode. When a new mode (other than Sleep) has been entered, the DAC1221 will execute a very brief internal power-up sequence of the analog and digital circuitry. In addition, the settling of the external V_{REF} and other circuitry must be taken into account to determine the amount of time required to resume normal operation.

Once serial communication is resumed, the Sleep Mode is exited by changing the MD1 - MD0 bits to any other mode. When a new mode (other than Sleep) has been entered, the DAC1221 will execute a very brief internal power-up sequence of the analog and digital circuitry. In addition, the settling of the external V_{REF} and other circuitry must be taken into account to determine the amount of time required to resume normal operation.

SERIAL INTERFACE

The DAC1221 includes a flexible serial interface which can be connected to microcontrollers and digital signal processors in a variety of ways. Along with this flexibility, there is also a good deal of complexity. This section describes the trade-offs between the different types of interfacing methods in a top-down approach—starting with the overall flow and control of serial data, moving to specific interface examples, and then providing information on various issues related to the serial interface.

Reset, Power-On Reset and Brown-Out

The DAC1221 contains an internal power-on reset circuit. If the power supply ramp rate is greater than 50mV/ms, this circuit will be adequate to ensure the device powers up correctly. Due to oscillator settling considerations, communication to and from the DAC1221 should not occur for at least 25ms after power is stable.

If this requirement cannot be met or if the circuit has brown-out considerations, the timing diagram of Figure 3 can be used to reset the DAC1221. This accomplishes the reset by controlling the duty cycle of the SCLK input.

Sleep mode is the default state after power on or reset. The output is high impedance during sleep mode.

I/O Recovery

If serial communication stops during an instruction or data transfer for longer than 100ms (for $f_{XIN} = 2.5\text{MHz}$), the DAC1221 will reset its serial interface. This will not affect the internal registers. The main controller must not continue the transfer after this event, but must restart the transfer from the beginning. This feature is very useful if the main controller can be reset at any point. After reset, simply wait 200ms (for $f_{XIN} = 2.5\text{MHz}$) before starting serial communication.

Isolation

The serial interface of the DAC1221 provides for simple isolation methods. An example of an isolated two-wire interface is shown in Figure 4.

Using $\overline{\text{CS}}$

The serial interface may make use of the $\overline{\text{CS}}$ signal, or this input may simply be tied LOW. There are several issues associated with choosing to do one or the other. The $\overline{\text{CS}}$ signal does not directly control the tri-state condition of the SDIO output. These signals are normally in the tri-state

condition. They only become active when serial data is being transmitted from the DAC1221. If the DAC1221 is in the middle of a serial transfer and the SDIO is an output, taking $\overline{\text{CS}}$ HIGH will not tri-state the output signal.

If there are multiple serial peripherals utilizing the same serial I/O lines and communication may occur with any peripheral at any time, the $\overline{\text{CS}}$ signal must be used. The $\overline{\text{CS}}$ signal is then used to enable communication with the DAC1221.

TIMING

The maximum serial clock frequency cannot exceed the DAC1221 X_{IN} frequency divided by 10. Table VIII and Figures 5 through 9 define the basic digital timing characteristics of the DAC1221. Figure 5 and the associated timing symbols apply to the X_{IN} input signal. Figures 6 through 9 and associated timing symbols apply to the serial interface signals (SCLK, SDIO, and $\overline{\text{CS}}$). The serial interface is discussed in detail in the Serial Interface section.

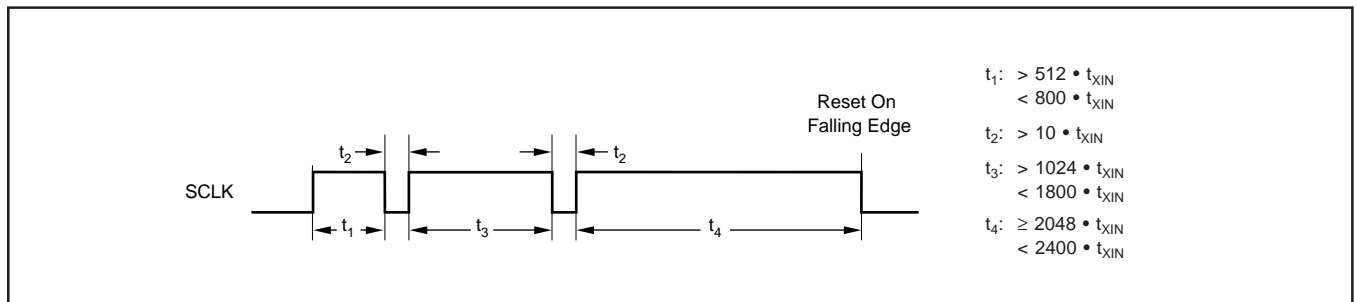

FIGURE 3. Resetting the DAC1221.

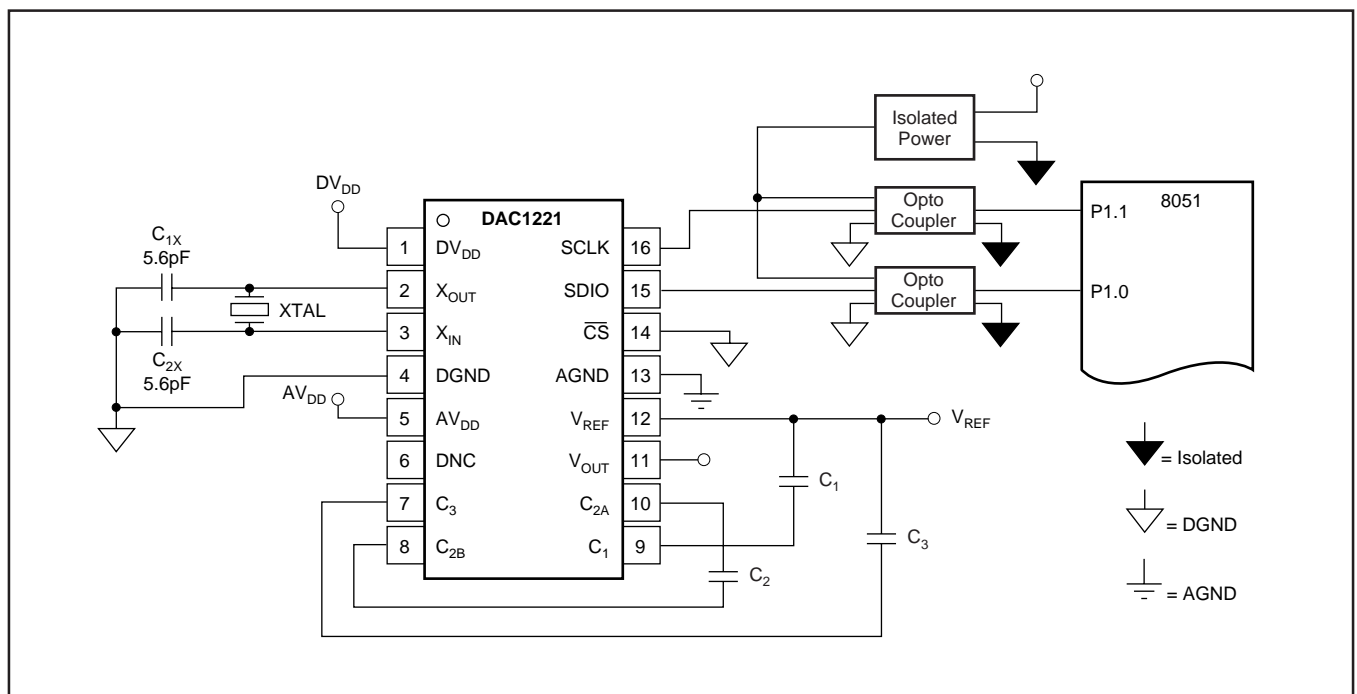

FIGURE 4. Isolation for Two-Wire Interface.

SYMBOL	DESCRIPTION	MIN	NOM	MAX	UNITS
f_{XIN}	X_{IN} Clock Frequency	1		2.5	MHz
t_{XIN}	X_{IN} Clock Period	400		1000	ns
t_1	X_{IN} Clock High	$0.4 \cdot t_{XIN}$			ns
t_2	X_{IN} Clock LOW	$0.4 \cdot t_{XIN}$			ns
t_3	SCLK HIGH	$5 \cdot t_{XIN}$			ns
t_4	SCLK LOW	$5 \cdot t_{XIN}$			ns
t_5	Data In Valid to SCLK Falling Edge (Setup)	40			ns
t_6	SCLK Falling Edge to Data In Not Valid (Hold)	20			ns
t_7	Data Out Valid After Rising Edge of SCLK (Hold)	0			ns
t_8	SCLK Rising Edge to New Data Out Valid (Delay) ⁽¹⁾			50	ns
t_9	Falling Edge of Last SCLK for INSR to Rising Edge of First SCLK for Register Data	$13 \cdot t_{XIN}$			ns
t_{10}	Falling Edge of \overline{CS} to Rising Edge of SCLK	$11 \cdot t_{XIN}$			ns
t_{11}	Falling Edge of Last SCLK for INSR to SDIO as Output	$8 \cdot t_{XIN}$		$10 \cdot t_{XIN}$	ns
t_{12}	SDIO as Output to Rising Edge of First SCLK for Register Data		$4 \cdot t_{XIN}$		ns
t_{13}	Falling Edge of Last SCLK for Register Data to SDIO Tri-State	$4 \cdot t_{XIN}$		$6 \cdot t_{XIN}$	ns
t_{14}	Falling Edge of Last SCLK for Register Data to Rising Edge of First SCLK of next INSR (\overline{CS} Tied LOW)	$41 \cdot t_{XIN}$			ns
t_{15}	Rising Edge of \overline{CS} to Falling Edge of \overline{CS} (Using \overline{CS})	$22 \cdot t_{XIN}$			ns

NOTE: (1) With 10pF load.

TABLE VIII. Digital Timing Characteristics.

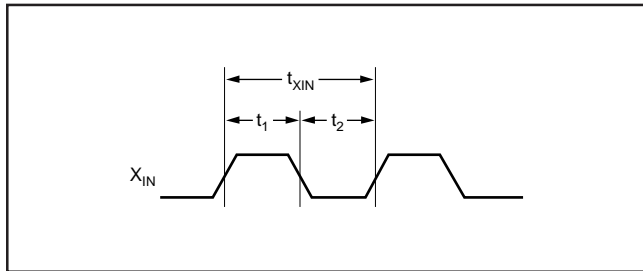

FIGURE 5. X_{IN} Clock Timing.

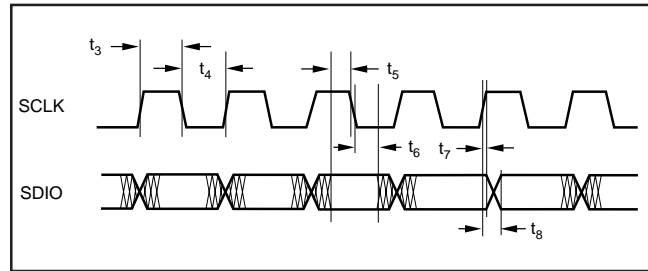

FIGURE 6. Serial Input/Output Timing.

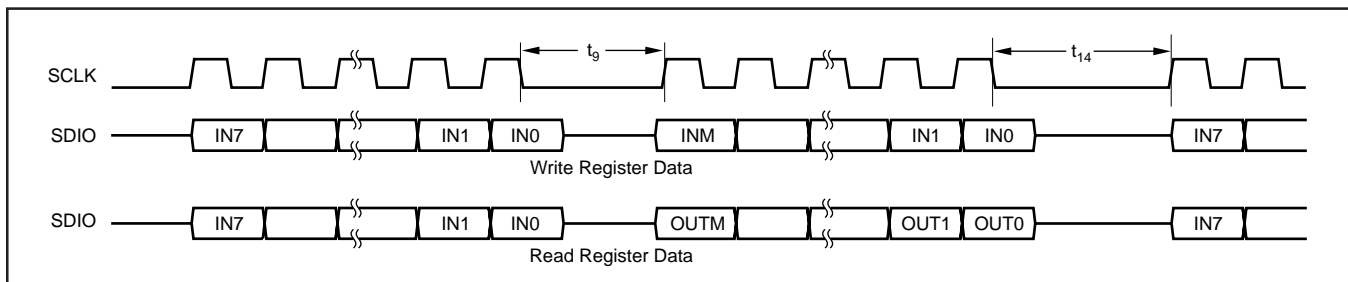

FIGURE 7. Serial Interface Timing (\overline{CS} always LOW).

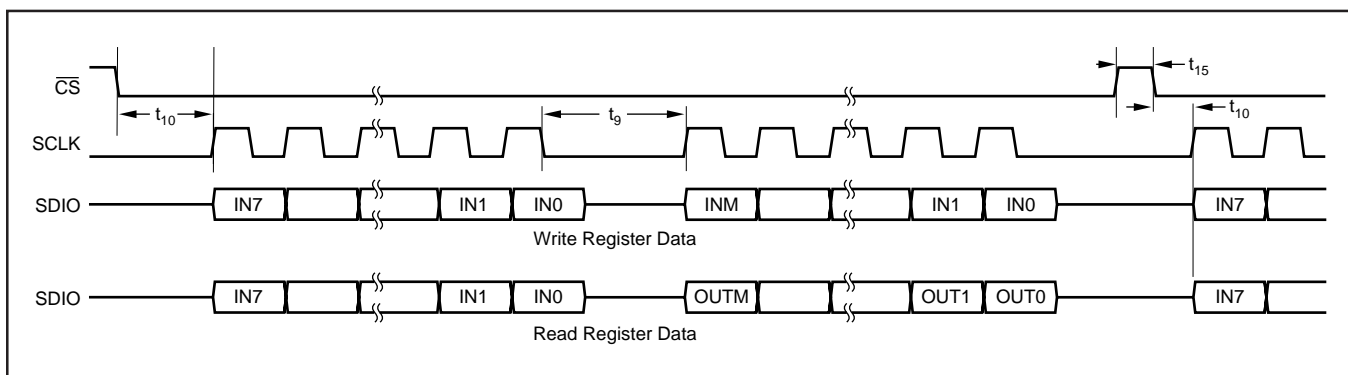

FIGURE 8. Serial Interface Timing (using \overline{CS}).

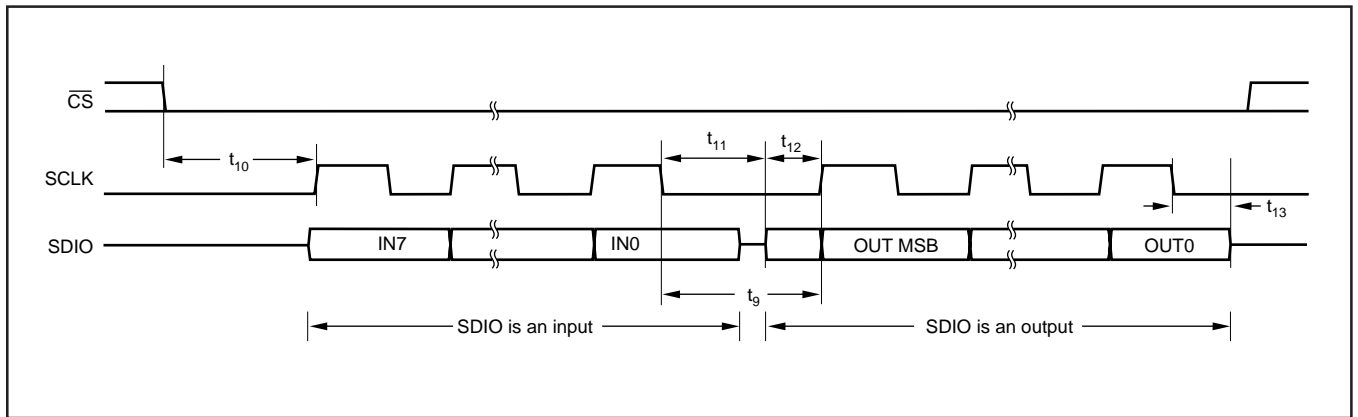

FIGURE 9. SDIO Input to Output Transition Timing.

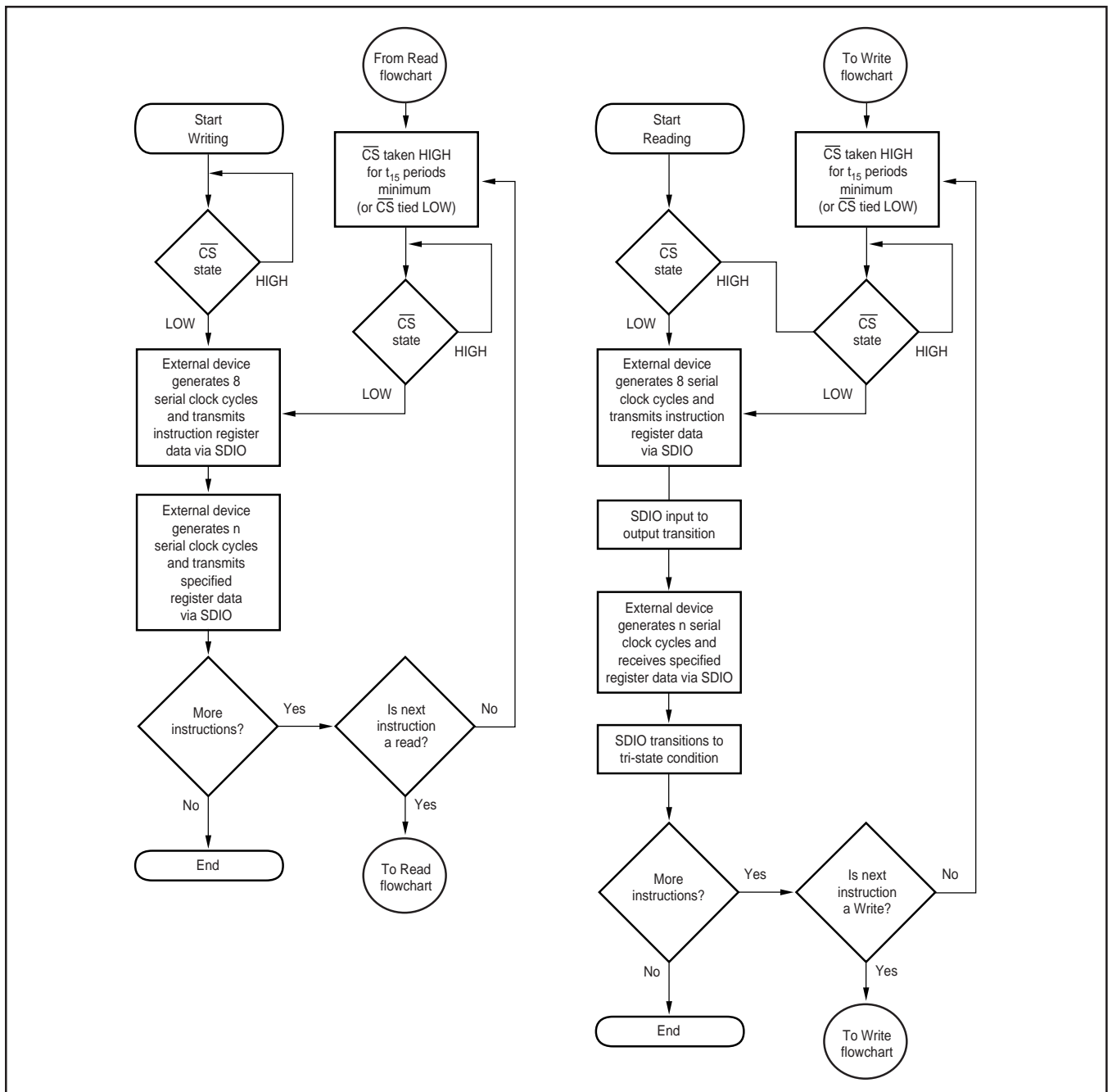

FIGURE 10. Flowchart for Writing and Reading Register Data.

LAYOUT

POWER SUPPLIES

The DAC1221 requires the digital supply (DV_{DD}) to be no greater than the analog supply (AV_{DD}) +0.3V. In the majority of systems, this means that the analog supply must come up first, followed by the digital supply and V_{REF} . Failure to observe this condition could cause permanent damage to the DAC1221.

Inputs to the DAC1221, such as SDIO or V_{REF} , should not be present before the analog and digital supplies are on. Violating this condition could cause latch-up. If these signals are present before the supplies are on, series resistors should be used to limit the input current.

The best scheme is to power the analog section of the design and AV_{DD} of the DAC1221 from one +3V supply, and the digital section (and DV_{DD}) from a separate +3V supply. The analog supply should come up first. This will ensure that SCLK, SDIO, \overline{CS} and V_{REF} do not exceed AV_{DD} , that the digital inputs are present only after AV_{DD} has been established, and that they do not exceed DV_{DD} .

The analog supply should be well regulated and low noise. For designs requiring very high resolution from the DAC1221, power supply rejection will be a concern. See the “PSRR vs Frequency” curve in the Typical Performance Curves section of this data sheet for more information.

The requirements for the digital supply are not as strict. However, high frequency noise on DV_{DD} can capacitively couple into the analog portion of the DAC1221. This noise can originate from switching power supplies, very fast microprocessors, or digital signal processors.

If one supply must be used to power the DAC1221, the AV_{DD} supply should be used to power DV_{DD} . This connection can be made via a 10 Ω resistor which, along with the decoupling capacitors, will provide some filtering between DV_{DD} and AV_{DD} . In some systems, a direct connection can be made. Experimentation may be the best way to determine the appropriate connection between AV_{DD} and DV_{DD} .

GROUNDING

The analog and digital sections of the design should be carefully and cleanly partitioned. Each section should have its own ground plane with no overlap between them. AGND should be connected to the analog ground plane, as well as all other analog grounds. DGND should be connected to the digital ground plane, and all digital signals referenced to this plane.

The DAC1221 pinout is such that the converter is cleanly separated into an analog and digital portion. This should allow simple layout of the analog and digital sections of the design.

For a single converter system, AGND and DGND of the DAC1221 should be connected together, underneath the converter. Do not join the ground planes. Instead, connect the two with a moderate signal trace. For multiple converters, connect the two ground planes at one location, as central to all of the converters as possible. In some cases, experimentation may be required to find the best point to connect the two planes together. The printed circuit board can be designed to provide different analog/digital ground connections via short jumpers. The initial prototype can be used to establish which connection works best.

DECOUPLING

Good decoupling practices should be used for the DAC1221 and for all components in the design. All decoupling capacitors, and specifically the 0.1 μ F ceramic capacitors, should be placed as close as possible to the pin being decoupled. A 1 μ F to 10 μ F capacitor, in parallel with a 0.1 μ F ceramic capacitor, should be used to decouple AV_{DD} to AGND. At a minimum, a 0.1 μ F ceramic capacitor should be used to decouple DV_{DD} to DGND, as well as for the digital supply on each digital component.

PACKAGING INFORMATION

Orderable Device	Status ⁽¹⁾	Package Type	Package Drawing	Pins	Package Qty	Eco Plan ⁽²⁾	Lead/Ball Finish	MSL Peak Temp ⁽³⁾
DAC1221E	ACTIVE	SSOP/ QSOP	DBQ	16	75	Green (RoHS & no Sb/Br)	CU NIPDAU	Level-2-260C-1 YEAR
DAC1221EG4	ACTIVE	SSOP/ QSOP	DBQ	16	75	Green (RoHS & no Sb/Br)	CU NIPDAU	Level-2-260C-1 YEAR

⁽¹⁾ The marketing status values are defined as follows:

ACTIVE: Product device recommended for new designs.

LIFEBUY: TI has announced that the device will be discontinued, and a lifetime-buy period is in effect.

NRND: Not recommended for new designs. Device is in production to support existing customers, but TI does not recommend using this part in a new design.

PREVIEW: Device has been announced but is not in production. Samples may or may not be available.

OBSOLETE: TI has discontinued the production of the device.

⁽²⁾ Eco Plan - The planned eco-friendly classification: Pb-Free (RoHS), Pb-Free (RoHS Exempt), or Green (RoHS & no Sb/Br) - please check <http://www.ti.com/productcontent> for the latest availability information and additional product content details.

TBD: The Pb-Free/Green conversion plan has not been defined.

Pb-Free (RoHS): TI's terms "Lead-Free" or "Pb-Free" mean semiconductor products that are compatible with the current RoHS requirements for all 6 substances, including the requirement that lead not exceed 0.1% by weight in homogeneous materials. Where designed to be soldered at high temperatures, TI Pb-Free products are suitable for use in specified lead-free processes.

Pb-Free (RoHS Exempt): This component has a RoHS exemption for either 1) lead-based flip-chip solder bumps used between the die and package, or 2) lead-based die adhesive used between the die and leadframe. The component is otherwise considered Pb-Free (RoHS compatible) as defined above.

Green (RoHS & no Sb/Br): TI defines "Green" to mean Pb-Free (RoHS compatible), and free of Bromine (Br) and Antimony (Sb) based flame retardants (Br or Sb do not exceed 0.1% by weight in homogeneous material)

⁽³⁾ MSL, Peak Temp. -- The Moisture Sensitivity Level rating according to the JEDEC industry standard classifications, and peak solder temperature.

Important Information and Disclaimer:The information provided on this page represents TI's knowledge and belief as of the date that it is provided. TI bases its knowledge and belief on information provided by third parties, and makes no representation or warranty as to the accuracy of such information. Efforts are underway to better integrate information from third parties. TI has taken and continues to take reasonable steps to provide representative and accurate information but may not have conducted destructive testing or chemical analysis on incoming materials and chemicals. TI and TI suppliers consider certain information to be proprietary, and thus CAS numbers and other limited information may not be available for release.

In no event shall TI's liability arising out of such information exceed the total purchase price of the TI part(s) at issue in this document sold by TI to Customer on an annual basis.

IMPORTANT NOTICE

Texas Instruments Incorporated and its subsidiaries (TI) reserve the right to make corrections, modifications, enhancements, improvements, and other changes to its products and services at any time and to discontinue any product or service without notice. Customers should obtain the latest relevant information before placing orders and should verify that such information is current and complete. All products are sold subject to TI's terms and conditions of sale supplied at the time of order acknowledgment.

TI warrants performance of its hardware products to the specifications applicable at the time of sale in accordance with TI's standard warranty. Testing and other quality control techniques are used to the extent TI deems necessary to support this warranty. Except where mandated by government requirements, testing of all parameters of each product is not necessarily performed.

TI assumes no liability for applications assistance or customer product design. Customers are responsible for their products and applications using TI components. To minimize the risks associated with customer products and applications, customers should provide adequate design and operating safeguards.

TI does not warrant or represent that any license, either express or implied, is granted under any TI patent right, copyright, mask work right, or other TI intellectual property right relating to any combination, machine, or process in which TI products or services are used. Information published by TI regarding third-party products or services does not constitute a license from TI to use such products or services or a warranty or endorsement thereof. Use of such information may require a license from a third party under the patents or other intellectual property of the third party, or a license from TI under the patents or other intellectual property of TI.

Reproduction of TI information in TI data books or data sheets is permissible only if reproduction is without alteration and is accompanied by all associated warranties, conditions, limitations, and notices. Reproduction of this information with alteration is an unfair and deceptive business practice. TI is not responsible or liable for such altered documentation. Information of third parties may be subject to additional restrictions.

Resale of TI products or services with statements different from or beyond the parameters stated by TI for that product or service voids all express and any implied warranties for the associated TI product or service and is an unfair and deceptive business practice. TI is not responsible or liable for any such statements.

TI products are not authorized for use in safety-critical applications (such as life support) where a failure of the TI product would reasonably be expected to cause severe personal injury or death, unless officers of the parties have executed an agreement specifically governing such use. Buyers represent that they have all necessary expertise in the safety and regulatory ramifications of their applications, and acknowledge and agree that they are solely responsible for all legal, regulatory and safety-related requirements concerning their products and any use of TI products in such safety-critical applications, notwithstanding any applications-related information or support that may be provided by TI. Further, Buyers must fully indemnify TI and its representatives against any damages arising out of the use of TI products in such safety-critical applications.

TI products are neither designed nor intended for use in military/aerospace applications or environments unless the TI products are specifically designated by TI as military-grade or "enhanced plastic." Only products designated by TI as military-grade meet military specifications. Buyers acknowledge and agree that any such use of TI products which TI has not designated as military-grade is solely at the Buyer's risk, and that they are solely responsible for compliance with all legal and regulatory requirements in connection with such use.

TI products are neither designed nor intended for use in automotive applications or environments unless the specific TI products are designated by TI as compliant with ISO/TS 16949 requirements. Buyers acknowledge and agree that, if they use any non-designated products in automotive applications, TI will not be responsible for any failure to meet such requirements.

Following are URLs where you can obtain information on other Texas Instruments products and application solutions:

Products

Amplifiers	amplifier.ti.com
Data Converters	dataconverter.ti.com
DLP® Products	www.dlp.com
DSP	dsp.ti.com
Clocks and Timers	www.ti.com/clocks
Interface	interface.ti.com
Logic	logic.ti.com
Power Mgmt	power.ti.com
Microcontrollers	microcontroller.ti.com
RFID	www.ti-rfid.com
RF/IF and ZigBee® Solutions	www.ti.com/lprf

Applications

Audio	www.ti.com/audio
Automotive	www.ti.com/automotive
Broadband	www.ti.com/broadband
Digital Control	www.ti.com/digitalcontrol
Medical	www.ti.com/medical
Military	www.ti.com/military
Optical Networking	www.ti.com/opticalnetwork
Security	www.ti.com/security
Telephony	www.ti.com/telephony
Video & Imaging	www.ti.com/video
Wireless	www.ti.com/wireless

Mailing Address: Texas Instruments, Post Office Box 655303, Dallas, Texas 75265
Copyright © 2009, Texas Instruments Incorporated

Looking for pricing, stock, or lifecycle information?

Click below to explore more details on WIN SOURCE:

 [View DAC1221E G4](#) on WIN SOURCE

 [Texas Instruments](#) Information

Optimize Your Supply Chain with WIN SOURCE Solutions

-  Global Sourcing Solution
-  Obsolete Management
-  Cost Control Management
-  Shortage Management
-  Alternative Solution
-  Excess Inventory Management