



**THE DATASHEET OF  
DAC3484IZAY**



## DAC3484 Quad-Channel, 16-Bit, 1.25 GSPS Digital-to-Analog Converter (DAC)

### 1 Features

- Very Low Power: 1.27 W at 1.25 GSPS, Full Operating Conditions
- Multi-DAC Synchronization
- Selectable 2x, 4x, 8x, 16x Interpolation Filter
  - Stop-Band Attenuation > 90 dBc
- Flexible On-chip Complex Mixing
  - Two Independent Fine Mixers with 32-Bit NCOs
  - Power Saving Coarse Mixers:  $\pm n \times F_s/8$
- High Performance, Low Jitter Clock Multiplying PLL
- Digital I and Q Correction
  - Gain, Phase, Offset, and Group Delay Correction
- Digital Inverse Sinc Filter
- Flexible 16-Bit LVDS Input Data Bus
  - 8 Sample Input FIFO
  - Data Pattern Checker
  - Parity Check
  - GC5330 Compatible
- Temperature Sensor
- Differential Scalable Output: 10 mA to 30 mA
- Multiple Package Options: 88-Pin 9x9mm WQFN and 196-Ball 12mmx12mm NFBGA (GREEN / Pb-Free)

### 2 Applications

- Cellular Base Stations
- Diversity Transmit
- Wideband Communications

### 3 Description

The DAC3484 is a very low power, high dynamic range, quad-channel, 16-bit digital-to-analog converter (DAC) with a sample rate as high as 1.25 GSPS.

The device includes features that simplify the design of complex transmit architectures: 2x to 16x digital interpolation filters with over 90dB of stop-band attenuation simplify the data interface and reconstruction filters. Independent complex mixers allow flexible carrier placement. A high-performance low jitter clock multiplier simplifies clocking of the device without significant impact on the dynamic range. The digital Quadrature Modulator Correction (QMC) enables complete IQ compensation for gain, offset, phase and group delay between channels in direct up-conversion applications.

Digital data is input to the device through a 16-bit LVDS data bus with on-chip termination. The device includes a FIFO, data pattern checker and parity test to ease the input interface. The interface also allows full synchronization of multiple devices.

The device is characterized for operation over the entire industrial temperature range of  $-40^{\circ}\text{C}$  to  $85^{\circ}\text{C}$  and is available in a very-small 88-pin 9x9mm WQFN package or 196-ball 12x12mm NFBGA package.

Very low power, small size, superior crosstalk, high dynamic range and features of the DAC3484 are an ideal fit for systems with multiple transmit channels.

#### Device Information<sup>(1)</sup>

PART NUMBER	PACKAGE	BODY SIZE (NOM)
DAC3484	WQFN (88)	9.00 mm x 9.00 mm
	NFBGA (196)	12.00 mm x 12.00 mm

(1) For all available packages, see the orderable addendum at the end of the data sheet.

#### Simplified Schematic

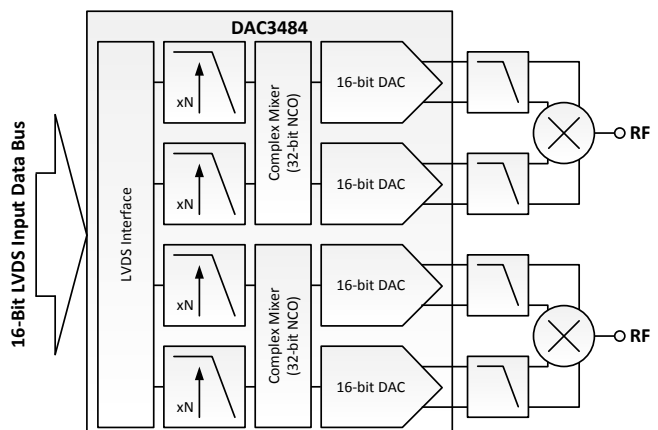

## Table of Contents

<b>1</b>	<b>Features</b> .....	<b>1</b>	7.3	Feature Description.....	<b>29</b>
<b>2</b>	<b>Applications</b> .....	<b>1</b>	7.4	Device Functional Modes.....	<b>58</b>
<b>3</b>	<b>Description</b> .....	<b>1</b>	7.5	Programming.....	<b>62</b>
<b>4</b>	<b>Revision History</b> .....	<b>2</b>	7.6	Register Map.....	<b>66</b>
<b>5</b>	<b>Pin Configuration and Functions</b> .....	<b>5</b>	<b>8</b>	<b>Application and Implementation</b> .....	<b>83</b>
<b>6</b>	<b>Specifications</b> .....	<b>11</b>	8.1	Application Information.....	<b>83</b>
6.1	Absolute Maximum Ratings .....	<b>11</b>	8.2	Typical Applications .....	<b>84</b>
6.2	ESD Ratings .....	<b>11</b>	<b>9</b>	<b>Power Supply Recommendations</b> .....	<b>90</b>
6.3	Recommended Operating Conditions.....	<b>11</b>	<b>10</b>	<b>Layout</b> .....	<b>91</b>
6.4	Thermal Information .....	<b>12</b>	10.1	Layout Guidelines .....	<b>91</b>
6.5	Electrical Characteristics – DC Specifications .....	<b>12</b>	10.2	Layout Examples.....	<b>92</b>
6.6	Electrical Characteristics – Digital Specifications .....	<b>14</b>	<b>11</b>	<b>Device and Documentation Support</b> .....	<b>95</b>
6.7	Electrical Characteristics – AC Specifications .....	<b>15</b>	11.1	Device Support.....	<b>95</b>
6.8	Timing Requirements – Digital Specifications.....	<b>15</b>	11.2	Documentation Support .....	<b>96</b>
6.9	Switching Characteristics – AC Specifications.....	<b>17</b>	11.3	Community Resources.....	<b>96</b>
6.10	Typical Characteristics .....	<b>18</b>	11.4	Trademarks .....	<b>96</b>
<b>7</b>	<b>Detailed Description</b> .....	<b>27</b>	11.5	Electrostatic Discharge Caution.....	<b>96</b>
7.1	Overview .....	<b>27</b>	11.6	Glossary .....	<b>96</b>
7.2	Functional Block Diagram .....	<b>28</b>	<b>12</b>	<b>Mechanical, Packaging, and Orderable Information</b> .....	<b>96</b>

## 4 Revision History

NOTE: Page numbers for previous revisions may differ from page numbers in the current version.

<b>Changes from Revision D (September 2015) to Revision E</b>	<b>Page</b>
• Changed $I_{(CLKVDD)}$ Clock supply current Mode 1 max value from 95mA to 100mA.....	<b>13</b>

<b>Changes from Revision C (August 2012) to Revision D</b>	<b>Page</b>
• Added <i>ESD Ratings</i> table, <i>Feature Description</i> section, <i>Device Functional Modes</i> , <i>Application and Implementation</i> section, <i>Power Supply Recommendations</i> section, <i>Layout</i> section, <i>Device and Documentation Support</i> section, and <i>Mechanical, Packaging, and Orderable Information</i> section. ....	<b>1</b>
• Added 196-ball 12x12mm BGA package to Description .....	<b>1</b>
• Added additional operation requirement for SLEEP pin if SLEEP pin is set to logic HIGH before and during device power up and initialization. ....	<b>7</b>
• Added additional circuit configuration for unused terminals - IOUTAP/N, IOUTBP/N, IOUTCP/N, IOUTDP/N .....	<b>9</b>
• Added additional operation requirement for SLEEP pin if SLEEP pin is set to logic HIGH before and during device power up and initialization. ....	<b>10</b>
• Changed DACCLKP/N Differential voltage TYP value from 1.0 V to 0.8 V .....	<b>14</b>
• Changed the parameter name Single-Ended Swing Level to Single-Ended Input Level to better reflect the specification for minimum recommended single-ended voltage level. ....	<b>14</b>
• Changed OSTRP/N Differential voltage TYP value from 1.0 V to 0.8 V .....	<b>14</b>
• Changed the parameter name Single-Ended Swing Level to Single-Ended Input Level to better reflect the specification for minimum recommended single-ended voltage level. ....	<b>14</b>
• Changed Standard high swing note for <i>Electrical Characteristics – Digital Specifications</i> .....	<b>14</b>
• Added Minimum voltage note for <i>Electrical Characteristics – Digital Specifications</i> .....	<b>14</b>
• Added LMK0480x family to note for <i>Timing Requirements – Digital Specifications</i> .....	<b>16</b>
• Added text to Input FIFO section .....	<b>32</b>
• Changed syncsel_fifoout(3:0) description in Input FIFO section to clarify the FIFO read pointer reset capture method and limitation.....	<b>33</b>

• Added Note to Input FIFO section .....	33
• Added LMK0480x family to Input FIFO section .....	33
• Changed text in Single Sync Source Mode to clarify the latency limitation of Single Sync Source Mode.....	35
• Added the effect of bypassing the FIFO in the Bypass Mode section to clarify the operation of the FIFO, LVDS FRAME, and LVDS SYNC in FIFO Bypass Mode. ....	35
• Added package information for LPF pin in PLL Mode section .....	37
• Changed table reference in FIR Filters section .....	38
• Added text to Data Pattern Checker section with additional operating recommendations. ....	49
• Added reference to application report in DAC3484 Alarm Monitoring section.....	53
• Added note to <a href="#">Figure 80</a> .....	54
• Added <a href="#">Unused LVDS Port Termination</a> section .....	55
• Changed information to Multi-Device Operation: Single Sync Source mode section to clarify the latency limitation of Single Sync Source Mode. ....	61
• Changed <a href="#">Figure 90</a> to clarify the latency limitation of Single Sync Source Mode. ....	62
• Changed the NCO setting description in the Example Start-up Sequence Section to reflect the example register writes. ....	64
• Added A32 to A32 for DAC3484IRKD and N9 for DAC3484IZAY in register config3 bit 0 description .....	70
• Changed alarm_lparity to alarm_fparity in register config7 .....	72
• Changed QMC offset registers to QMC correction registers in register config16 .....	74
• Added SLEEP pin information to register config27 bit 11 .....	77
• Changed 1.2VDIG to DIGVDD in register config27 bits 5:0.....	77
• Changed 1.2VCLK to CLKVDD in register config27 bits 5:0.....	77
• Added pin description for both packages in register config35 .....	80
• Added reference to Digital Input Timing Specifications Table in register config36 .....	80
• Added text to register config45 bit 0 description .....	81

**Changes from Revision B (February) to Revision C**
**Page**

• Deleted T <sub>J</sub> row from top of thermal table.....	2
• Added thermal information to the Absolute Maximum Ratings table .....	11
• Added Recommended Operating Conditions table .....	11
• Deleted T <sub>J</sub> row from top of thermal table.....	12
• Deleted OPERATING RANGE section from bottom of Electrical Characteristics – DC Specifications table .....	13

**Changes from Revision A (July 2011) to Revision B**
**Page**

• Changed the revision from A, July 2011 to B, June 2012.....	1
• Changed Package options in FEATURES .....	1
• Added ZAY package information to Thermal Information .....	2
• Added ZAY package.....	8
• Added ZAY pin functions .....	9
• Added ZAY package information to Thermal Information .....	12
• Added Input Common Mode max value of 1.6V .....	14
• Added information to CLOCK INPUT (DACCLKP/N) in Electrical Characteristics – Digital Specifications .....	14
• Added information to OUTPUT STROBE (OSTRP/N) in Electrical Characteristics – Digital Specifications .....	14
• Changed Electrical Characteristics – AC Specifications AC Performance information.....	15
• Changed <a href="#">Figure 21</a> .....	20
• Changed <a href="#">Figure 22</a> .....	20
• Changed <a href="#">Figure 23</a> .....	20

**DAC3484**

SLAS749E – MARCH 2011 – REVISED NOVEMBER 2015

[www.ti.com](http://www.ti.com)

• Added <a href="#">Figure 48</a> .....	24
• Added <a href="#">Figure 49</a> .....	25
• Changed config 3 to config9 in Input FIFO section .....	32
• Added information for double-charge-pump current to PLL MODE section .....	37
• Changed <a href="#">Figure 71</a> .....	43
• Changed +3.75 to –3.75 degrees in 1024 steps to +26.5 to –26.5 degrees in 4096 steps in GAIN AND PHASE CORRECTION section .....	45
• Added dual channel mode enable information to POWER-UP SEQUENCE step 6 .....	62
• Changed config1, bit 8 in <a href="#">Table 11</a> .....	66
• Changed config16, bits 13:12 in <a href="#">Table 11</a> .....	66
• Changed register config1, bit8 from Reserved to quad_ena .....	69
• Changed register config16, bits 13:12 from reserved to dual_ena (1:0) .....	74

**Changes from Original (March 2011) to Revision A**
**Page**

• Changed from PRODUCT PREVIEW to PRODUCTION DATA .....	1
---	---

## 5 Pin Configuration and Functions

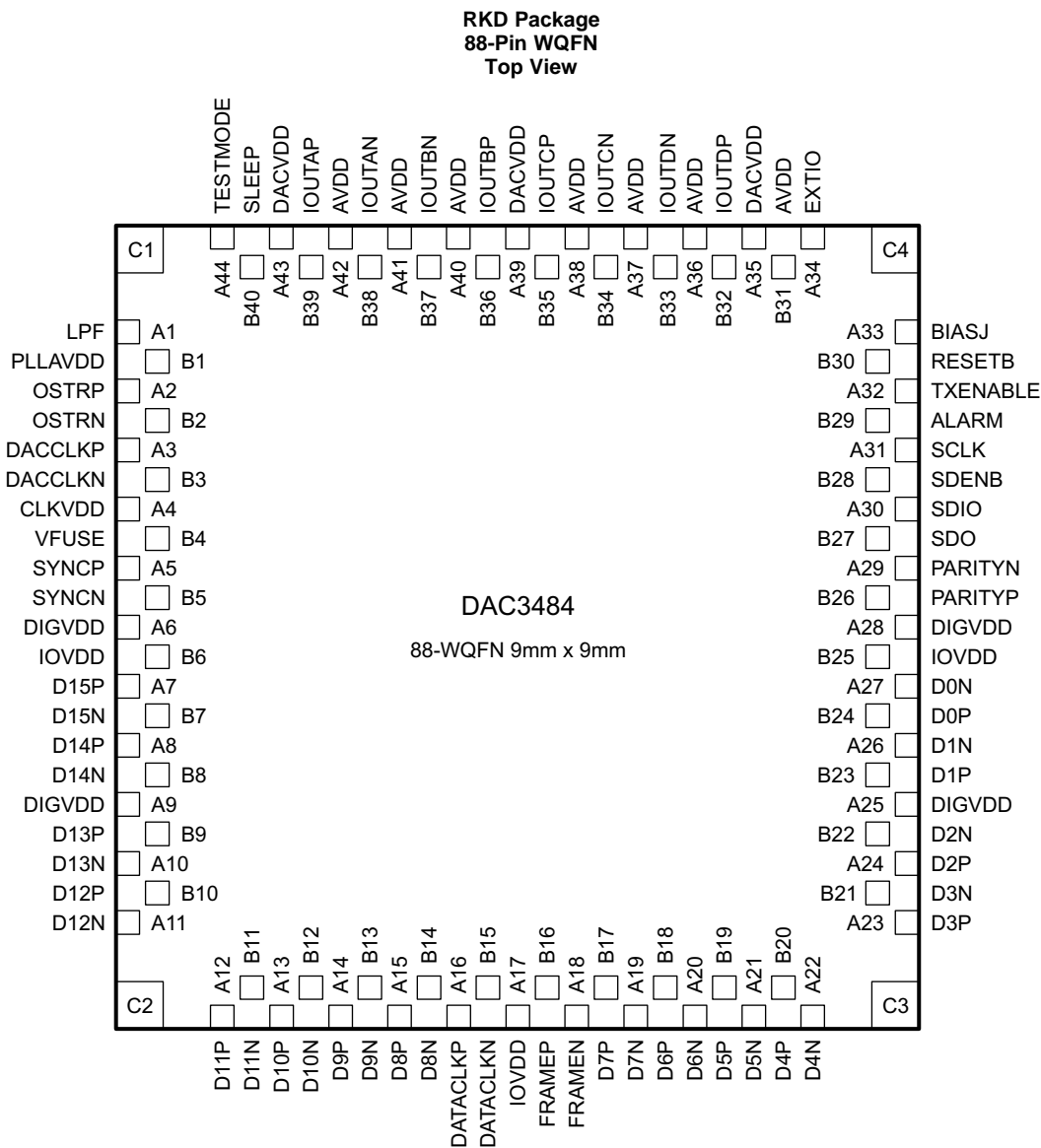

P0133-02

### Pin Functions - WQFN

PIN		I/O	DESCRIPTION
NAME	NO.		
AVDD	A36, A37, A38, A40, A41, A42, B31	I	Analog supply voltage. (3.3 V)
ALARM	B29	O	CMOS output for ALARM condition. The ALARM output functionality is defined through the <i>config7</i> register. Default polarity is active high, but can be changed to active low via <i>config0 alarm_out_pol</i> control bit.
BIASJ	A33	O	Full-scale output current bias. For 30-mA full-scale output current, connect 1.28 kΩ to ground. Change the full-scale output current through <i>coarse_dac(3:0)</i> in <i>config3, bit&lt;15:12&gt;</i>
CLKVDD	A4	I	Internal clock buffer supply voltage. (1.2 V) It is recommended to isolate this supply from DIGVDD and DACVDD.

**Pin Functions - WQFN (continued)**

PIN		I/O	DESCRIPTION
NAME	NO.		
D[15..0]P	A7, A8, B9, B10, A12, A13, A14, A15, B17, B18, B19, B20, A23, A24, B23, B24	I	LVDS positive input data bits 0 through 15. Internal 100-Ω termination resistor. Data format relative to DATACLKP/N clock is Double Data Rate (DDR). D15P is most significant data bit (MSB) D0P is least significant data bit (LSB)  The order of the bus can be reversed via <i>config2 revbus</i> bit.
D[15..0]N	B7, B8, A10, A11, B11, B12, B13, B14, A19, A20, A21, A22, B21, B22, A26, A27	I	LVDS negative input data bits 0 through 15. (See D[15:0]P description above)
DACCLKP	A3	I	Positive external LVPECL clock input for DAC core with a self-bias.
DACCLKN	B3	I	Complementary external LVPECL clock input for DAC core. (see the DACCLKP description)
DACVDD	A35, A39, A43	I	DAC core supply voltage. (1.2 V). It is recommended to isolate this supply from CLKVDD and DIGVDD.
DATACLKP	A16	I	LVDS positive input data clock. Internal 100 Ω termination resistor. Input data D[15:0]P/N is latched on both edges of DATACLKP/N (Double Data Rate).
DATACLKN	B15	I	LVDS negative input data clock. (See DATACLKP description)
DIGVDD	A6, A9, A25, A28	I	Digital supply voltage. (1.2 V). It is recommended to isolate this supply from CLKVDD and DACVDD.
EXTIO	A34	I/O	Used as external reference input when internal reference is disabled through <i>config27 extref_ena</i> = 1b. Used as internal reference output when <i>config27 extref_ena</i> = 0b (default). Requires a 0.1-μF decoupling capacitor to AGND when used as reference output.
FRAMEP	B16	I	LVDS frame indicator positive input. Internal 100-Ω termination resistor. The main functions of this input are to reset the FIFO pointer or to be used as a syncing source. These two functions are captured with the rising edge of DATACLKP/N. The signal captured by the falling edge of DATACLKP/N can be used as a block parity bit. The FRAMEP/N signal should be edge-aligned with D[15:0]P/N. Additionally it is used to indicate the beginning of the frame.
FRAMEN	A18	I	LVDS frame indicator negative input. (See the FRAMEP description)
GND	C1, C2, C3, C4, Thermal Pad	I	These pins are ground for all supplies.
IOUTAP	B39	O	A-Channel DAC current output. Connect directly to ground if unused.
IOUTAN	B38	O	A-Channel DAC complementary current output. Connect directly to ground if unused.
IOUTBP	B36	O	B-Channel DAC current output. Connect directly to ground if unused.
IOUTBN	B37	O	B-Channel DAC complementary current output. Connect directly to ground if unused.
IOUTCP	B35	O	C-Channel DAC current output. Connect directly to ground if unused.
IOUTCN	B34	O	C-Channel DAC complementary current output. Connect directly to ground if unused.
IOUTDP	B32	O	D-Channel DAC current output. Connect directly to ground if unused.
IOUTDN	B33	O	D-Channel DAC complementary current output. Connect directly to ground if unused.
IOVDD	B6, A17, B25	I	Supply voltage for all digital I/O. (3.3 V)
LPF	A1	I/O	PLL loop filter connection. If not using the clock multiplying PLL, the LPF pin can be left unconnected.
OSTRP	A2	I	LVPECL output strobe positive input. This positive/negative pair is captured with the rising edge of DACCLKP/N. It is used for multiple DAC synchronization. If unused it can be left unconnected.
OSTRN	B2	I	LVPECL output strobe negative input. (See the OSTRP description)
PARITYP	B26	I	Optional LVDS positive input parity bit. The PARITYP/N LVDS pair has an internal 100 Ω termination resistor. If unused it can be left unconnected.
PARITYN	A29	I	Optional LVDS negative input parity bit.
PLLAVDD	B1	I	PLL analog supply voltage. (3.3 V)

**Pin Functions - WQFN (continued)**

PIN		I/O	DESCRIPTION
NAME	NO.		
SCLK	A31	I	Serial interface clock. Internal pull-down.
SDENB	B28	I	Active low serial data enable, always an input to the DAC3484. Internal pull-up.
SDIO	A30	I/O	Serial interface data. Bi-directional in 3-pin mode (default) and uni-directional 4-pin mode. Internal pull-down.
SDO	B27	O	Uni-directional serial interface data in 4-pin mode. The SDO pin is tri-stated in 3-pin interface mode (default).
SLEEP	B40	I	Active high asynchronous hardware power-down input. Internal pull-down. If SLEEP pin is set to logic HIGH before and during device power-up and initialization, the fuse_sleep bit in register 0x1B, bit 11 must be written after register 0x23 during device initialization register setup.
SYNCP	A5	I	Optional LVDS SYNC positive input. The SYNCP/N LVDS pair has an internal 100-Ω termination resistor. If unused it can be left unconnected.
SYNCPN	B5	I	Optional LVDS SYNC negative input.
RESETB	B30	I	Active low input for chip RESET, which resets all the programming registers to their default state. Internal pull-up.
TXENABLE	A32	I	Transmit enable active high input. Internal pull-down. To enable analog output data transmission, set <i>sif_txenable</i> in register <i>config3</i> to 1b or pull CMOS TXENABLE pin to high. To disable analog output, set <i>sif_txenable</i> to 0b and pull CMOS TXENABLE pin to low. The DAC output is forced to midscale.
TESTMODE	A44	I	This pin is used for factory testing. Internal pull-down. <b>Leave unconnected for normal operation.</b>
VFUSE	B4	I	Digital supply voltage. This supply pin is also used for factory fuse programming. <b>Connect to DACVDD for normal operation.</b>

**ZAY Package  
196-Pin NFBGA  
Top View**

	A	B	C	D	E	F	G	H	J	K	L	M	N	P
14	GND	IOUT AP	IOUT AN	GND	IOUT BN	IOUT BP	GND	GND	IOUT CP	IOUT CN	GND	IOUT DN	IOUT DP	GND
13	GND	GND	GND	GND	GND	GND	GND	GND	GND	GND	GND	GND	GND	GND
12	DAC CLKP	GND	CLK VDD	LPF	GND	GND	EXTIO	BIASJ	GND	N/C	N/C	GND	ALARM	SDO
11	DAC CLKN	GND	PLL AVDD	PLL AVDD	AVDD	AVDD	AVDD	AVDD	AVDD	AVDD	N/C	GND	N/C	SDIO
10	GND	GND	GND	AVDD	DAC VDD	DAC VDD	DAC VDD	DAC VDD	DAC VDD	DAC VDD	AVDD	GND	RESET B	SDENB
9	OS TRP	OS TRN	GND	DAC VDD	DAC VDD	GND	GND	GND	GND	DAC VDD	DAC VDD	GND	TX ENABLE	SCLK
8	TEST MODE	SLEEP	GND	GND	GND	GND	GND	GND	GND	GND	GND	GND	N/C	N/C
7	N/C	N/C	GND	VFUSE	DIG VDD	GND	GND	GND	GND	DIG VDD	N/C	GND	N/C	N/C
6	N/C	N/C	GND	IO VDD	DIG VDD	GND	GND	GND	GND	DIG VDD	IO VDD	GND	N/C	N/C
5	SYNCP	SYNCN	GND	IO VDD	DIG VDD	DIG VDD	IO VDD	IO VDD	DIG VDD	DIG VDD	IO VDD	GND	PARITY P	PARITY N
4	D15P	D15N	N/C	N/C	N/C	N/C	N/C	N/C	N/C	N/C	N/C	N/C	D0P	D0N
3	D14P	D14N	N/C	N/C	N/C	N/C	N/C	N/C	N/C	N/C	N/C	N/C	D1P	D1N
2	D13P	D13N	D11P	D10P	D9P	D8P	DATA CLKP	FRAME P	D7P	D6P	D5P	D4P	D2P	D2N
1	D12P	D12N	D11N	D10N	D9N	D8N	DATA CLKN	FRAME N	D7N	D6N	D5N	D4N	D3P	D3N

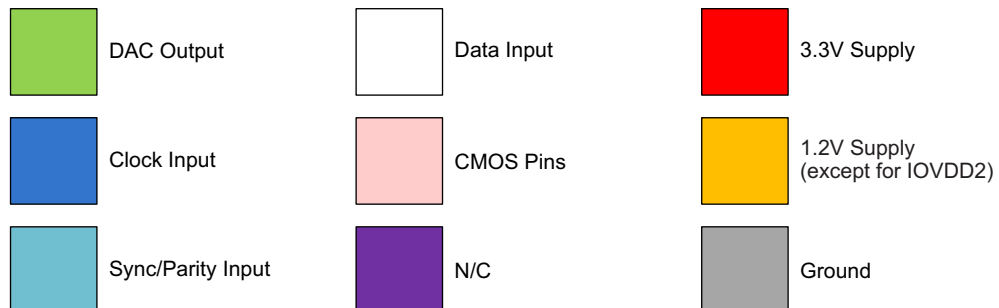

P0134-02

**Pin Functions - NFBGA**

PIN		I/O	DESCRIPTION
NAME	NO.		
AVDD	D10, E11, F11, G11, H11, J11, K11, L10	I	Analog supply voltage. (3.3 V)
ALARM	N12	O	CMOS output for ALARM condition. The ALARM output functionality is defined through the <i>config7</i> register. Default polarity is active low, but can be changed to active high via <i>config0 alarm_out_pol</i> control bit.
BIASJ	H12	O	Full-scale output current bias. For 30-mA full-scale output current, connect 1.28 k $\Omega$ to ground. Change the full-scale output current through <i>coarse_dac(3:0)</i> in <i>config3</i> , <i>bit&lt;15:12&gt;</i>
CLKVDD	C12	I	Internal clock buffer supply voltage. (1.2 V) It is recommended to isolate this supply from DIGVDD and DACVDD.
D[15..0]P	N4, N3, N2, N1, M2, L2, K2, J2, F2, E2, D2, C2, A1, A2, A3, A4	I	LVDS positive input data bits 0 through 15. Internal 100- $\Omega$ termination resistor. Data format relative to DATACLKP/N clock is Double Data Rate (DDR). D15P is most significant data bit (MSB) D0P is least significant data bit (LSB) The order of the bus can be reversed via <i>config2 revbus</i> bit.
D[15..0]N	P4, P3, P2, P1, M1, L1, K1, J1, F1, E1, D1, C1, B1, B2, B3, B4	I	LVDS negative input data bits 0 through 15. (See D[15:0]P description above)
DACCLKP	A12	I	Positive external LVPECL clock input for DAC core with a self-bias.
DACCLKN	A11	I	Complementary external LVPECL clock input for DAC core. (see the DACCLKP description)
DACVDD	D9, E9, E10, F10, G10, H10, J10, K9, K10, L9	I	DAC core supply voltage. (1.2 V). It is recommended to isolate this supply from CLKVDD and DIGVDD.
DATACLKP	G2	I	LVDS positive input data clock. Internal 100- $\Omega$ termination resistor. Input data D[15:0]P/N is latched on both edges of DATACLKP/N (Double Data Rate).
DATACLKN	G1	I	LVDS negative input data clock. (See DATACLKP description)
DIGVDD	E5, E6, E7, F5, J5, K5, K6, K7	I	Digital supply voltage. (1.2 V). It is recommended to isolate this supply from CLKVDD and DACVDD.
EXTIO	G12	I/O	Used as external reference input when internal reference is disabled through <i>config27 extref_ena</i> = 1b. Used as internal reference output when <i>config27 extref_ena</i> = 0b (default). Requires a 0.1- $\mu$ F decoupling capacitor to AGND when used as reference output.
FRAMEP	H2	I	LVDS frame indicator positive input. Internal 100- $\Omega$ termination resistor. The main functions of this input are to reset the FIFO pointer or to be used as a syncing source. These two functions are captured with the rising edge of DATACLKP/N. The signal captured by the falling edge of DATACLKP/N can be used as a block parity bit. The FRAMEP/N signal should be edge-aligned with D[15:0]P/N. Additionally it is used to indicate the beginning of the frame.
FRAMEN	H1	I	LVDS frame indicator negative input. (See the FRAMEP description)
GND	A10, A13, A14, B10, B11, B12, B13, C5, C6, C7, C8, C9, C10, C13, D8, D13, D14, E8, E12, E13, F6, F7, F8, F9, F12, F13, G6, G7, G8, G9, G13, G14, H6, H7, H8, H9, H13, H14, J6, J7, J8, J9, J12, J13, K8, K13, L8, L13, L14, M5, M6, M7, M8, M9, M10, M11, M12, M13, N13, P13, P14	I	These pins are ground for all supplies.
IOUTAP	B14	O	A-Channel DAC current output. Connect directly to ground if unused.
IOUTAN	C14	O	A-Channel DAC complementary current output. Connect directly to ground if unused.
IOUTBP	F14	O	B-Channel DAC current output. Connect directly to ground if unused.
IOUTBN	E14	O	B-Channel DAC complementary current output. Connect directly to ground if unused.
IOUTCP	J14	O	C-Channel DAC current output. Connect directly to ground if unused.

**Pin Functions - NFBGA (continued)**

PIN		I/O	DESCRIPTION
NAME	NO.		
IOUTCN	K14	O	C-Channel DAC complementary current output. Connect directly to ground if unused.
IOUTDP	N14	O	D-Channel DAC current output. Connect directly to ground if unused.
IOUTDN	M14	O	D-Channel DAC complementary current output. Connect directly to ground if unused.
IOVDD	D5, D6, G5, H5, L5, L6	I	Supply voltage for all digital I/O. (3.3 V)
LPF	D12	I	PLL loop filter connection. If not using the clock multiplying PLL, the LPF pin can be left unconnected.
OSTRP	A9	I	LVPECL output strobe positive input. This positive/negative pair is captured with the rising edge of DACCLKP/N. It is used for multiple DAC synchronization. If unused it can be left unconnected.
OSTRN	B9	I	LVPECL output strobe negative input. (See the OSTRP description)
PARITYP	N5	I	Optional LVDS positive input parity bit. The PARITYP/N LVDS pair has an internal 100-Ω termination resistor. If unused it can be left unconnected.
PARITYN	P5	I	Optional LVDS negative input parity bit.
PLLAVDD	C11, D11	I	PLL analog supply voltage. (3.3 V)
SCLK	P9	I	Serial interface clock. Internal pull-down.
SDENB	P10	I	Active low serial data enable, always an input to the DAC3484. Internal pull-up.
SDIO	P11	I/O	Serial interface data. Bi-directional in 3-pin mode (default) and 4-pin mode. Internal pull-down.
SDO	P12	O	Uni-directional serial interface data in 4-pin mode. The SDO pin is three-stated in 3-pin interface mode (default).
SLEEP	B8	I	Active high asynchronous hardware power-down input. Internal pull-down. If SLEEP pin is set to logic HIGH before and during device power-up and initialization, the fuse_sleep bit in register 0x1B, bit 11 must be written after register 0x23 during device initialization register setup.
SYNCP	A5	I	Optional LVDS SYNC positive input. The SYNCP/N LVDS pair has an internal 100-Ω termination resistor. If unused it can be left unconnected.
SYNCN	B5	I	LVDS SYNC negative input.
RESETB	N10	I	Active low input for chip RESET, which resets all the programming registers to their default state. Internal pull-up.
TXENABLE	N9	I	Transmit enable active high input. Internal pull-down. To enable analog output data transmission, set <i>sif_txenable</i> in register <i>config3</i> to 1b or pull CMOS TXENABLE pin to high. To disable analog output, set <i>sif_txenable</i> to 0b and pull CMOS TXENABLE pin to low. The DAC output is forced to midscale.
TESTMODE	A8	O	This pin is used for factory testing. Internal pull-down. <b>Leave unconnected for normal operation.</b>
VFUSE	D7	I	Digital supply voltage. This supply pin is also used for factory fuse programming. <b>Connect to DACVDD for normal operation.</b>

## 6 Specifications

### 6.1 Absolute Maximum Ratings

over operating free-air temperature range (unless otherwise noted)<sup>(1)</sup>

		MIN	MAX	UNIT
Supply voltage range <sup>(2)</sup>	DACVDD, DIGVDD, CLKVDD	-0.5	1.5	V
	VFUSE	-0.5	1.5	V
	IOVDD	-0.5	4	V
	AVDD, PLLAVDD	-0.5	4	V
Pin voltage range <sup>(2)</sup>	D[15..0]P/N, DATACLKP/N, FRAMEP/N, PARITYP/N, SYNCN/P	-0.5	IOVDD + 0.5	V
	DACCLKP/N, OSTRP/N	-0.5	CLKVDD + 0.5	V
	ALARM, SDO, SDIO, SCLK, SDENB, SLEEP, RESETB, TESTMODE, TXENABLE	-0.5	IOVDD + 0.5	V
	IOUTAP/N, IOUTBP/N, IOUTCP/N, IOUTDP/N	-1.0	AVDD + 0.5	V
	EXTIO, BIASJ	-0.5	AVDD + 0.5	V
	LPF	0.5	PLLA VDD+0.5V	V
Peak input current (any input)			20	mA
Peak total input current (all inputs)			-30	mA
Operating free-air temperature range, T <sub>A</sub> : DAC3484		-40	85	°C
Absolute maximum junction temperature, T <sub>J</sub>			150	°C
Storage temperature range		-65	150	°C

- (1) Stresses beyond those listed under absolute maximum ratings may cause permanent damage to the device. These are stress ratings only and functional operation of these or any other conditions beyond those indicated under "recommended operating conditions" is not implied. Exposure to absolute-maximum-rated conditions for extended periods may affect device reliability.
- (2) Measured with respect to GND.

### 6.2 ESD Ratings

		VALUE	UNIT
V <sub>(ESD)</sub> Electrostatic discharge	Human-body model (HBM), per ANSI/ESDA/JEDEC JS-001 <sup>(1)</sup>	±2000	V
	Charged-device model (CDM), per JEDEC specification JESD22-C101 <sup>(2)</sup>	±500	

- (1) JEDEC document JEP155 states that 500-V HBM allows safe manufacturing with a standard ESD control process.
- (2) JEDEC document JEP157 states that 250-V CDM allows safe manufacturing with a standard ESD control process.

### 6.3 Recommended Operating Conditions

		MIN	NOM	MAX	UNIT
T <sub>J</sub>	Recommended operating junction temperature			105	°C
	Maximum rated operating junction temperature <sup>(1)</sup>	125			
T <sub>A</sub>	Recommended free-air temperature	-40	25	85	°C

- (1) Prolonged use at this junction temperature may increase the device failure-in-time (FIT) rate.

## 6.4 Thermal Information

THERMAL METRIC <sup>(1)</sup>		DAC3484		UNIT
		RKD (WQFN-MR)	ZAY (NFBGA)	
		88 PINS	196 BALLS	
R <sub>θJA</sub>	Junction-to-ambient thermal resistance	22.1	37.6	°C/W
R <sub>θJctop</sub>	Junction-to-case (top) thermal resistance	7.1	6.8	°C/W
R <sub>θJCbot</sub>	Junction-to-case (bottom) thermal resistance	0.6	N/A	°C/W
θ <sub>JB</sub>	Junction-to-board thermal resistance	4.7	16.8	°C/W
ψ <sub>JT</sub>	Junction-to-top characterization parameter	0.1	0.2	°C/W
ψ <sub>JB</sub>	Junction-to-board characterization parameter	4.6	16.4	°C/W

(1) For more information about traditional and new thermal metrics, see the *Semiconductor and IC Package Thermal Metrics* application report (SPRA953).

## 6.5 Electrical Characteristics – DC Specifications<sup>(1)</sup>

over recommended operating free-air temperature range, nominal supplies, I<sub>OUT,FS</sub> = 20 mA (unless otherwise noted)

PARAMETER		TEST CONDITIONS	MIN	TYP	MAX	UNIT
Resolution			16			Bits
<b>DC ACCURACY</b>						
DNL	Differential nonlinearity	1 LSB = I <sub>OUT,FS</sub> /2 <sup>16</sup>		±2		LSB
INL	Integral nonlinearity			±4		LSB
<b>ANALOG OUTPUT</b>						
Coarse gain linearity				±0.04		LSB
Offset error		Mid code offset		±0.001		%FSR
Gain error		With external reference		±2		%FSR
		With internal reference		±2		%FSR
Gain mismatch		With internal reference		±2		%FSR
Full scale output current			10	20	30	mA
Output compliance range			-0.5		0.6	V
Output resistance				300		kΩ
Output capacitance				5		pF
<b>REFERENCE OUTPUT</b>						
V <sub>REF</sub>	Reference output voltage			1.2		V
	Reference output current <sup>(2)</sup>			100		nA
<b>REFERENCE INPUT</b>						
V <sub>EXTIO</sub>	Input voltage range	External Reference Mode	0.6	1.2	1.25	V
	Input resistance			1		
	Small signal bandwidth			472		kHz
	Input capacitance			100		pF
<b>TEMPERATURE COEFFICIENTS</b>						
Offset drift				±1		ppm/°C
Gain drift		with external reference		±15		ppm/°C
		with internal reference		±30		ppm/°C
Reference voltage drift				±8		ppm/°C

(1) Measured differentially across IOU<sub>TP/N</sub> with 25 Ω each to GND.

(2) Use an external buffer amplifier with high impedance input to drive any external load.

**Electrical Characteristics – DC Specifications<sup>(1)</sup> (continued)**

over recommended operating free-air temperature range, nominal supplies,  $I_{OUT_{FS}} = 20 \text{ mA}$  (unless otherwise noted)

PARAMETER		TEST CONDITIONS	MIN	TYP	MAX	UNIT
<b>POWER SUPPLY<sup>(3)</sup></b>						
AVDD, IOVDD, PLLAVDD		All Conditions	3.14	3.3	3.46	V
DIGVDD		All Conditions	1.14	1.2	1.32	V
CLKVDD, DACVDD		$f_{DAC}$ Sampling Rate $\leq 1.25$ GSPS, PLL OFF $f_{DAC}$ Sampling Rate $\leq 1$ GSPS, PLL ON	1.14	1.2	1.32	V
		$f_{DAC}$ Sampling Rate $> 1$ GSPS, PLL ON	1.25	1.29	1.32	
PSRR	Power Supply Rejection Ratio	DC tested		$\pm 0.2$		%FSR/V
<b>POWER CONSUMPTION</b>						
$I_{(AVDD)}$	Analog supply current <sup>(4)</sup>	MODE 1 $f_{DAC} = 1.25$ GSPS, 4x interpolation, Mixer on, QMC on, invsinc on, PLL enabled, 20-mA FS output, IF = 200 MHz		123	135	mA
$I_{(DIGVDD)}$	Digital supply current			595	650	mA
$I_{(DACVDD)}$	DAC supply current			35	50	mA
$I_{(CLKVDD)}$	Clock supply current			90	100	mA
P	Power dissipation			1270	1320	mW
$I_{(AVDD)}$	Analog supply current <sup>(4)</sup>	MODE 2 $f_{DAC} = 1.25$ GSPS, 4x interpolation, Mixer on, QMC on, invsinc on, PLL disabled, 20-mA FS output, IF = 200 MHz		107		mA
$I_{(DIGVDD)}$	Digital supply current			595		mA
$I_{(DACVDD)}$	DAC supply current			38		mA
$I_{(CLKVDD)}$	Clock supply current			71		mA
P	Power dissipation			1198		mW
$I_{(AVDD)}$	Analog supply current <sup>(4)</sup>	MODE 3 $f_{DAC} = 625$ MSPS, 2x interpolation, Mixer on, QMC on, invsinc off, PLL disabled, 20-mA FS output, IF = 200 MHz		107		mA
$I_{(DIGVDD)}$	Digital supply current			282		mA
$I_{(DACVDD)}$	DAC supply current			20		mA
$I_{(CLKVDD)}$	Clock supply current			41		mA
P	Power dissipation			765		mW
$I_{(AVDD)}$	Analog supply current <sup>(4)</sup>	MODE 4 $f_{DAC} = 1.25$ GSPS, 4x interpolation, Mixer on, QMC on, invsinc on, PLL enabled, Channels A/B/C/D output sleep, IF = 200 MHz,		35		mA
$I_{(DIGVDD)}$	Digital supply current			595		mA
$I_{(DACVDD)}$	DAC supply current			38		mA
$I_{(CLKVDD)}$	Clock supply current			90		mA
P	Power dissipation			984		mW
$I_{(AVDD)}$	Analog supply current <sup>(4)</sup>	Mode 5 Power-Down mode: No clock, DAC on sleep mode (clock receiver sleep), Channels A/B/C/D output sleep, static data pattern		20		mA
$I_{(DIGVDD)}$	Digital supply current			10		mA
$I_{(DACVDD)}$	DAC supply current			4		mA
$I_{(CLKVDD)}$	Clock supply current			10		mA
P	Power Dissipation			95		mW
$I_{(AVDD)}$	Analog supply current <sup>(4)</sup>	Mode 6 $f_{DAC} = 1$ GSPS, 8x interpolation, Mixer off, QMC on, invsinc off, PLL enabled, 20-mA FS output, IF = 200 MHz		107		mA
$I_{(DIGVDD)}$	Digital supply current			333		mA
$I_{(DACVDD)}$	DAC supply current			35		mA
$I_{(CLKVDD)}$	Clock supply current			60		mA
P	Power dissipation			867		mW
$I_{(AVDD)}$	Analog supply current <sup>(4)</sup>	Mode 7 $f_{DAC} = 737.28$ MSPS, 4x interpolation, Mixer on, QMC on, invsinc off, PLL enabled, 20-mA FS output, IF = 150 MHz		123		mA
$I_{(DIGVDD)}$	Digital supply current			323		mA
$I_{(DACVDD)}$	DAC supply current			23		mA
$I_{(CLKVDD)}$	Clock supply current			69		mA
P	Power dissipation			904		mW

(3) To ensure power supply accuracy and to account for power supply filter network loss at operating conditions, the use of the ATEST function in register config27 to check the internal power supply nodes is recommended.

(4) Includes AVDD, PLLAVDD, and IOVDD

## 6.6 Electrical Characteristics – Digital Specifications

over operating free-air temperature range (unless otherwise noted)

PARAMETER		TEST CONDITIONS	MIN	TYP	MAX	UNIT
<b>LVDS INPUTS: D[15:0]P/N, DATACLKP/N, FRAMEP/N, SYNCN/P, PARITYN/P<sup>(1)</sup></b>						
V <sub>A,B+</sub>	Logic high differential input voltage threshold		200			mV
V <sub>A,B-</sub>	Logic low differential input voltage threshold				-200	mV
V <sub>COM</sub>	Input Common Mode		1.0	1.2	1.6	V
Z <sub>T</sub>	Internal termination		85	110	135	Ω
C <sub>L</sub>	LVDS Input capacitance			2		pF
f <sub>INTERL</sub>	Interleaved LVDS data transfer rate				1250	MSPS
f <sub>DATA</sub>	Input data rate				312.5	MSPS
<b>CLOCK INPUT (DACCLKP/N)</b>						
	Differential voltage <sup>(2)</sup>	DACCLKP - DACCLKN	0.4	0.8		V
	Internally biased common-mode voltage			0.2		V
	Single-ended input level <sup>(3)</sup>		-0.4			V
<b>OUTPUT STROBE (OSTRP/N)</b>						
	Differential voltage	OSTRP - OSTRN	0.4	0.8		V
	Internally biased common-mode voltage			0.2		V
	Single-ended input level <sup>(3)</sup>		-0.4			V
<b>CMOS INTERFACE: ALARM, SDO, SDIO, SCLK, SDENB, SLEEP, RESETB, TXENABLE</b>						
V <sub>IH</sub>	High-level input voltage		2			V
V <sub>IL</sub>	Low-level input voltage				0.8	V
I <sub>IH</sub>	High-level input current		-40		40	μA
I <sub>IL</sub>	Low-level input current		-40		40	μA
C <sub>I</sub>	CMOS Input capacitance			2		pF
V <sub>OH</sub>	ALARM, SDO, SDIO	I <sub>load</sub> = -100 μA	IOVDD - 0.2			V
		I <sub>load</sub> = -2 mA	0.8 x IOVDD			V
V <sub>OL</sub>	ALARM, SDO, SDIO	I <sub>load</sub> = 100 μA			0.2	V
		I <sub>load</sub> = 2 mA			0.5	V

 (1) See [LVDS Inputs](#) section for terminology.

(2) Standard high swing LVPECL clock signal should be applied for best performance.

(3) Indicates the minimum voltage that can be applied to the DACCLK and OSTR differential pins in single-ended fashion.

## 6.7 Electrical Characteristics – AC Specifications

over recommended operating free-air temperature range, nominal supplies,  $I_{OUT_{FS}} = 20\text{mA}$  (unless otherwise noted)

PARAMETER		TEST CONDITIONS	MIN	TYP	MAX	UNIT
<b>ANALOG OUTPUT<sup>(1)</sup></b>						
$f_{DAC}$	Maximum DAC rate		1250			MSPS
<b>AC PERFORMANCE<sup>(2)</sup></b>						
SFDR	Spurious free dynamic range (0 to $f_{DAC}/2$ ) Tone at 0 dBFS	$f_{DAC} = 1.25\text{ GSPS}$ , $f_{OUT} = 20\text{ MHz}$		82		dBc
		$f_{DAC} = 1.25\text{ GSPS}$ , $f_{OUT} = 50\text{ MHz}$		77		
		$f_{DAC} = 1.25\text{ GSPS}$ , $f_{OUT} = 70\text{ MHz}$		72		
IMD3	Third-order two-tone intermodulation distortion Each tone at -12 dBFS	$f_{DAC} = 1.25\text{ MSPS}$ , $f_{OUT} = 30 \pm 0.5\text{ MHz}$		81		dBc
		$f_{DAC} = 1.25\text{ GSPS}$ , $f_{OUT} = 50 \pm 0.5\text{ MHz}$		79		
		$f_{DAC} = 1.25\text{ GSPS}$ , $f_{OUT} = 100 \pm 0.5\text{ MHz}$		77.5		
NSD	Noise Spectral Density Tone at 0dBFS	$f_{DAC} = 1.25\text{ GSPS}$ , $f_{OUT} = 10\text{ MHz}$		160		dBc/Hz
		$f_{DAC} = 1.25\text{ GSPS}$ , $f_{OUT} = 80\text{ MHz}$		155		
ACLR <sup>(3)</sup>	Adjacent channel leakage ratio, single carrier	$f_{DAC} = 1.2288\text{ GSPS}$ , $f_{OUT} = 30.72\text{ MHz}$		77		dBc
		$f_{DAC} = 1.2288\text{ GSPS}$ , $f_{OUT} = 153.6\text{ MHz}$		74		
	Alternate channel leakage ratio, single carrier	$f_{DAC} = 1.2288\text{ GSPS}$ , $f_{OUT} = 30.72\text{ MHz}$		82		
		$f_{DAC} = 1.2288\text{ GSPS}$ , $f_{OUT} = 153.6\text{ MHz}$		80		
Channel Isolation		$f_{DAC} = 1.25\text{ GSPS}$ , $f_{OUT} = 10\text{ MHz}$		84		dBc

(1) Measured single ended into 50-Ω load.

(2) 4:1 transformer output termination, 50 Ω doubly terminated load.

(3) Single carrier, W-CDMA with 3.84-MHz BW, 5-MHz spacing, centered at IF, PAR = 12dB. TESTMODEL 1, 10 ms

## 6.8 Timing Requirements – Digital Specifications

			MIN	NOM	MAX	UNIT	
<b>CLOCK INPUT (DACCLKP/N)</b>							
Duty cycle			40%		60%		
DACCLKP/N input frequency					1250	MHz	
<b>OUTPUT STROBE (OSTRP/N)</b>							
$f_{OSTR}$	Frequency	$f_{OSTR} = f_{DACCLK} / (n \times 8 \times \text{Interp})$ where n is any positive integer, $f_{DACCLK}$ is DACCLK frequency in MHz			$f_{DACCLK} / (8 \times \text{interp})$	MHz	
Duty cycle				50%			
<b>DIGITAL INPUT TIMING SPECIFICATIONS</b>							
<b>Timing LVDS inputs: D[15:0]P/N, FRAMEP/N, SYNCN/P, PARITYP/N, double edge latching</b>							
$t_{S(DATA)}$	Setup time, D[15:0]P/N, FRAMEP/N, SYNCN/P and PARITYP/N, valid to either edge of DATACLKP/N	FRAMEP/N reset and frame indicator latched on rising edge of DATACLKP/N. FRAMEP/N parity bit latched on falling edge of DATACLKP/N.	Config36 Setting			ps	
			datadly	clkdly			
			0	0			150
			0	1			100
			0	2			50
			0	3			0
			0	4			-50
			0	5			-100
			0	6			-150
			0	7			-200
			1	0			200
			2	0			250
			3	0			300
4	0	350					
5	0	400					
6	0	450					
7	0	500					

**Timing Requirements – Digital Specifications (continued)**

			MIN	NOM	MAX	UNIT
$t_{h(DATA)}$	Hold time, D[15:0]P/N, FRAMEP/N, SYNCN/P and PARITYP/N, valid after either edge of DATACLKP/N	FRAMEP/N reset and frame indicator latched on rising edge of DATACLKP/N. FRAMEP/N parity bit latched on falling edge of DATACLKP/N.	Config36 Setting			ps
			datadly	clkdly		
			0	0	350	
			0	1	400	
			0	2	450	
			0	3	500	
			0	4	550	
			0	5	600	
			0	6	650	
			0	7	700	
			1	0	300	
			2	0	250	
			3	0	200	
			4	0	150	
5	0	100				
6	0	50				
7	0	0				
$t_{(FRAME\_SYNC)}$	FRAMEP/N and SYNCN/P pulse width	$f_{DATACLK}$ is DATACLK frequency in MHz	$1/2f_{DATACLK}$		ns	
<b>TIMING OUTPUT STROBE INPUT: DACCLKP/N rising edge LATCHING<sup>(1)</sup></b>						
$t_{s(OSTR)}$	Setup time, OSTRP/N valid to rising edge of DACCLKP/N		0		ps	
$t_{h(OSTR)}$	Hold time, OSTRP/N valid after rising edge of DACCLKP/N		300		ps	
<b>TIMING SYNC INPUT: DACCLKP/N rising edge LATCHING<sup>(2)</sup></b>						
$t_{s(SYNC\_PLL)}$	Setup time, SYNCN/P valid to rising edge of DACCLKP/N		200		ps	
$t_{h(SYNC\_PLL)}$	Hold time, SYNCN/P valid after rising edge of DACCLKP/N		300		ps	
<b>TIMING SERIAL PORT</b>						
$t_{s(SDENB)}$	Setup time, SDENB to rising edge of SCLK		20		ns	
$t_{s(SDIO)}$	Setup time, SDIO valid to rising edge of SCLK		10		ns	
$t_{h(SDIO)}$	Hold time, SDIO valid to rising edge of SCLK		5		ns	
$t_{(SCLK)}$	Period of SCLK	Register <i>config6</i> read (temperature sensor read)	1		µs	
		All other registers	100		ns	
$t_{d(Data)}$	Data output delay after falling edge of SCLK		10		ns	
$t_{RESET}$	Minimum RESETB pulse width		25		ns	

- (1) OSTR is required in Dual Sync Sources mode. In order to minimize the skew it is recommended to use the same clock distribution device such as Texas Instruments CDCE62005 or LMK0480x family to provide the DACCLK and OSTR signals to all the DAC3484 devices in the system. Swap the polarity of the DACCLK outputs with respect to the OSTR ones to establish proper phase relationship.
- (2) SYNC is required to synchronize the PLL circuit in multiple devices. The SYNC signal must meet the timing relationship with respect to the reference clock (DACCLKP/N) of the on-chip PLL circuit.

## 6.9 Switching Characteristics – AC Specifications

over recommended operating free-air temperature range, nominal supplies,  $I_{OUT_{FS}} = 20 \text{ mA}$  (unless otherwise noted)

PARAMETER		TEST CONDITIONS	MIN	TYP	MAX	UNIT
<b>ANALOG OUTPUT<sup>(1)</sup></b>						
$t_{s(DAC)}$	Output settling time to 0.1%	Transition: Code 0x0000 to 0xFFFF		10		ns
$t_{pd}$	Output propagation delay	DAC outputs are updated on the falling edge of DAC clock. Does not include Digital Latency (see below).		2		ns
$t_{r(IOUT)}$	Output rise time 10% to 90%			220		ps
$t_{f(IOUT)}$	Output fall time 90% to 10%			220		ps
Digital latency		No interpolation, FIFO on, Mixer off, QMC off, Inverse sinc off		128		DAC clock cycles
		2x Interpolation		216		
		4x Interpolation		376		
		8x Interpolation		726		
		16x Interpolation		1427		
		Fine mixer		24		
		QMC		32		
Power-up Time	DAC wake-up time	IOUT current settling to 1% of $I_{OUT_{FS}}$ from output sleep		2		$\mu\text{s}$
	DAC sleep time	IOUT current settling to less than 1% of $I_{OUT_{FS}}$ in output sleep		2		

(1) Measured single ended into 50- $\Omega$  load.

### 6.10 Typical Characteristics

All plots are at 25°C, nominal supply voltage,  $f_{DAC} = 1250$  MSPS, 4x interpolation, NCO enabled, Mixer Gain disabled, QMC enabled with gain set at 1446 for both I/Q channels, 0 dBFS digital input, 20-mA full-scale output current with 4:1 transformer (unless otherwise noted)

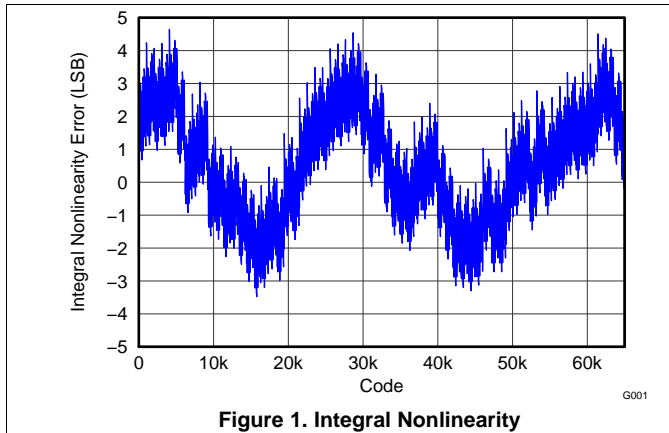

Figure 1. Integral Nonlinearity

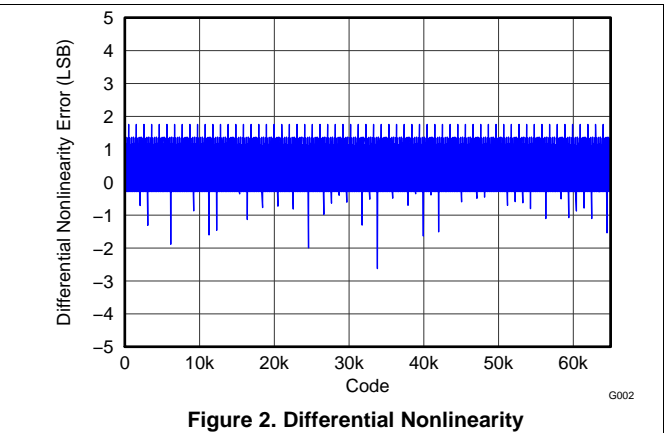

Figure 2. Differential Nonlinearity

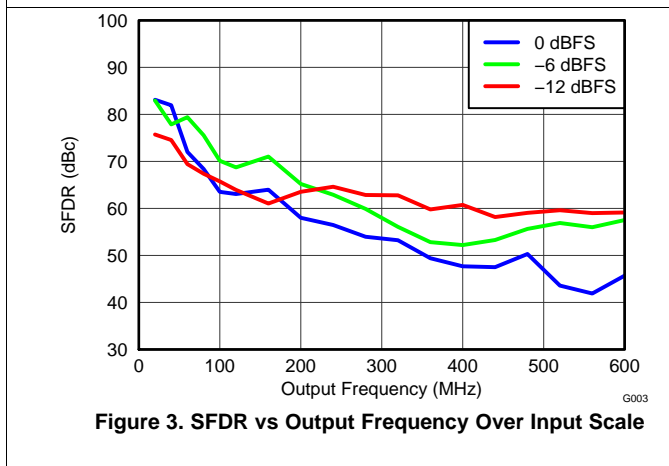

Figure 3. SFDR vs Output Frequency Over Input Scale

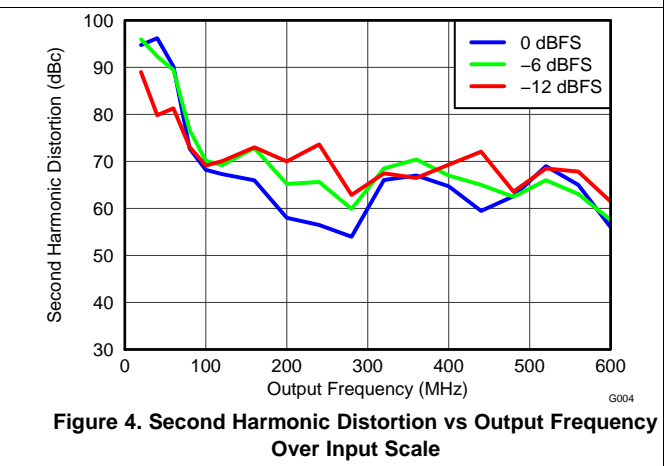

Figure 4. Second Harmonic Distortion vs Output Frequency Over Input Scale

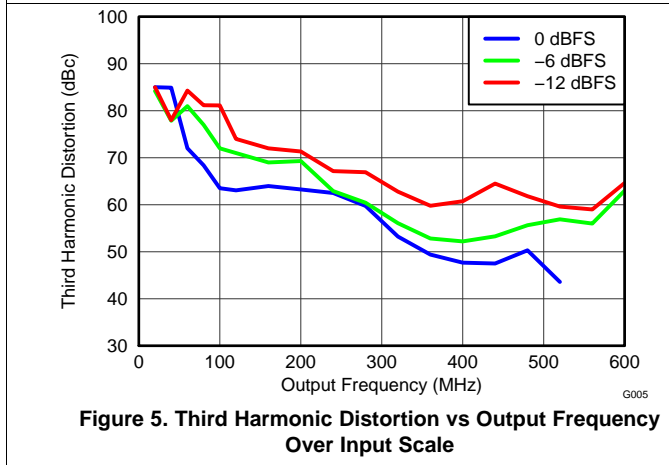

Figure 5. Third Harmonic Distortion vs Output Frequency Over Input Scale

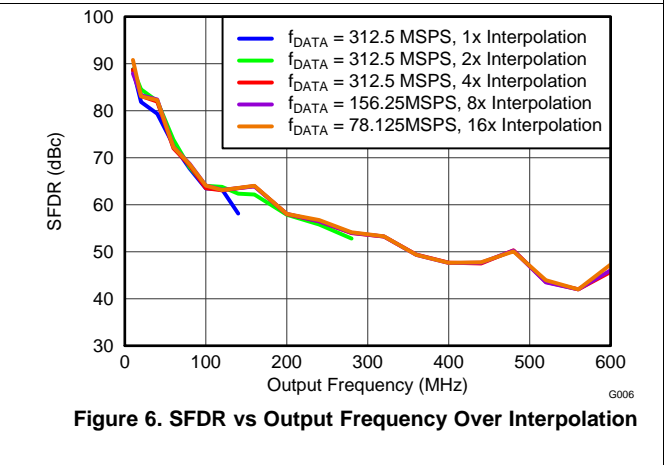
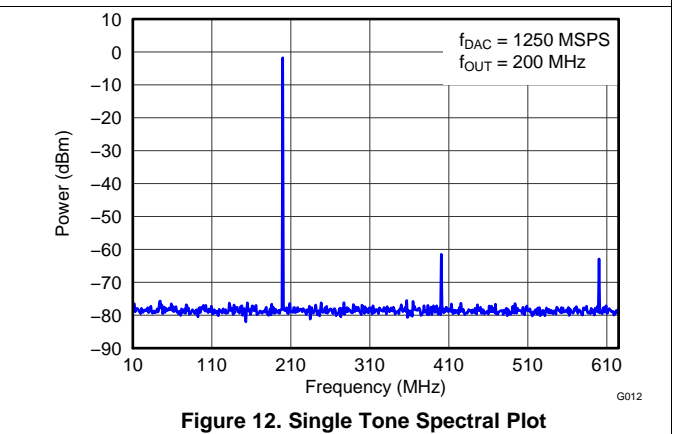
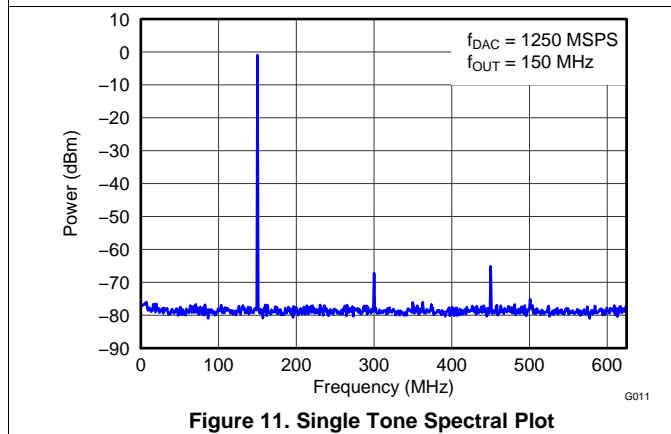
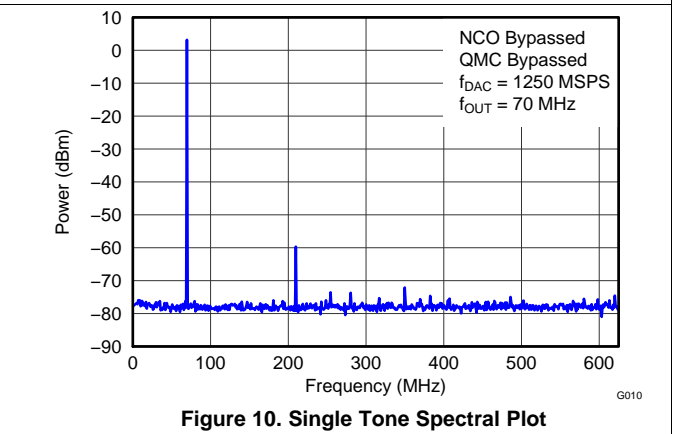
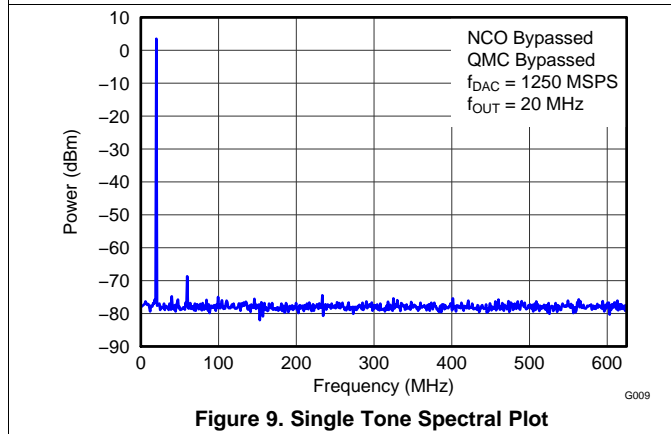
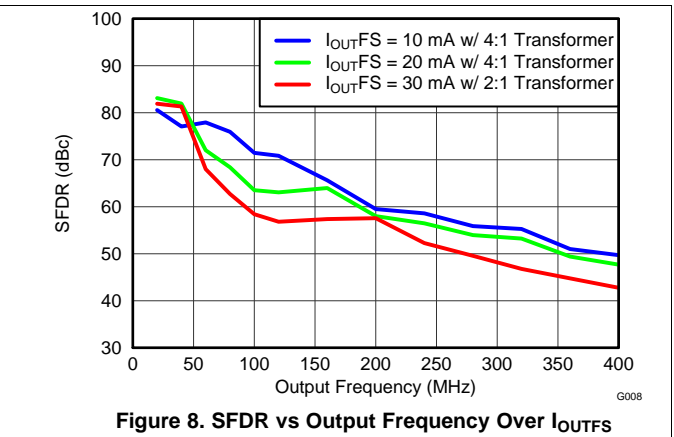
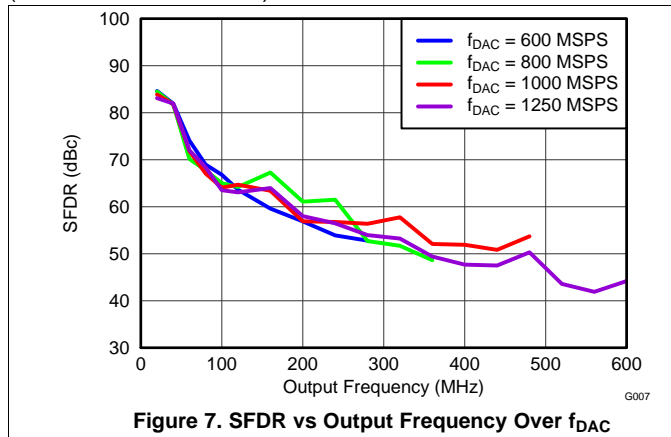

Figure 6. SFDR vs Output Frequency Over Interpolation

### Typical Characteristics (continued)

All plots are at 25°C, nominal supply voltage,  $f_{DAC} = 1250$  MSPS, 4x interpolation, NCO enabled, Mixer Gain disabled, QMC enabled with gain set at 1446 for both I/Q channels, 0 dBFS digital input, 20-mA full-scale output current with 4:1 transformer (unless otherwise noted)



### Typical Characteristics (continued)

All plots are at 25°C, nominal supply voltage,  $f_{DAC} = 1250$  MSPS, 4x interpolation, NCO enabled, Mixer Gain disabled, QMC enabled with gain set at 1446 for both I/Q channels, 0 dBFS digital input, 20-mA full-scale output current with 4:1 transformer (unless otherwise noted)

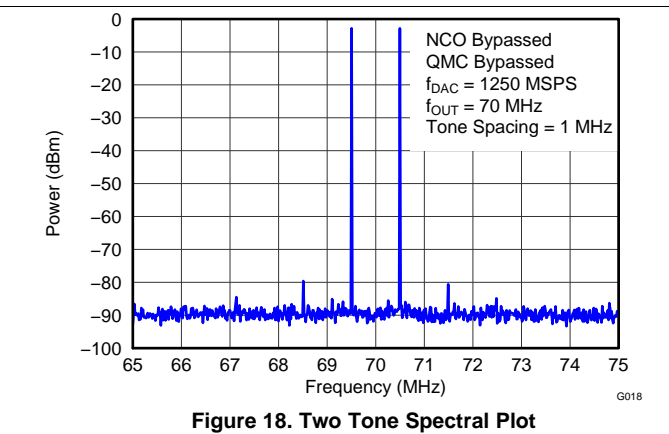
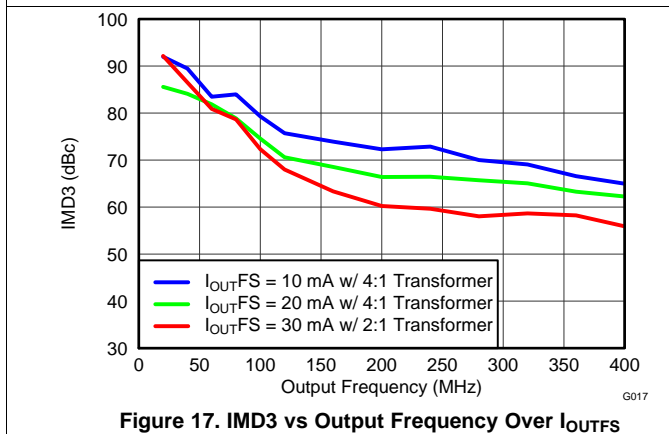
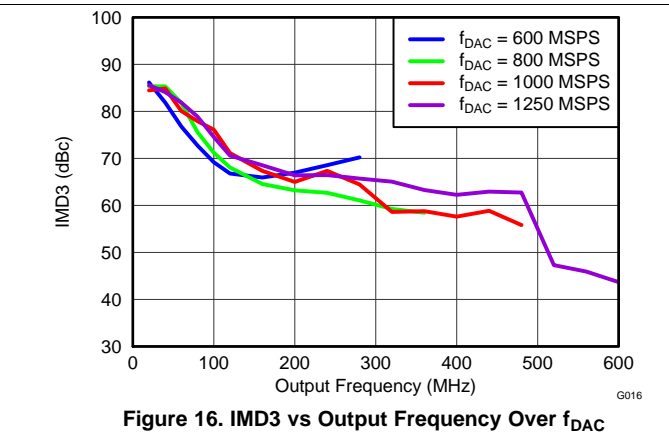
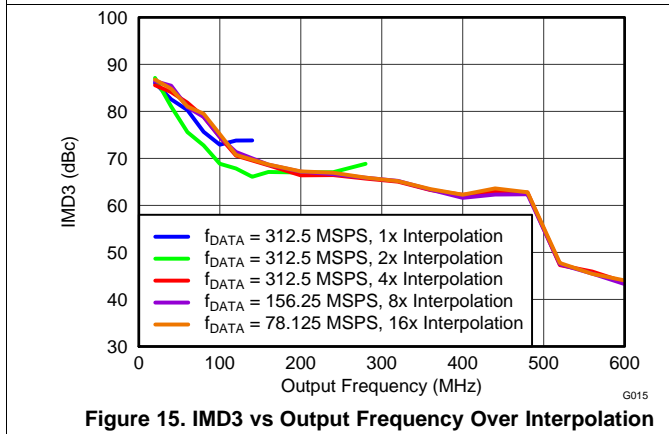
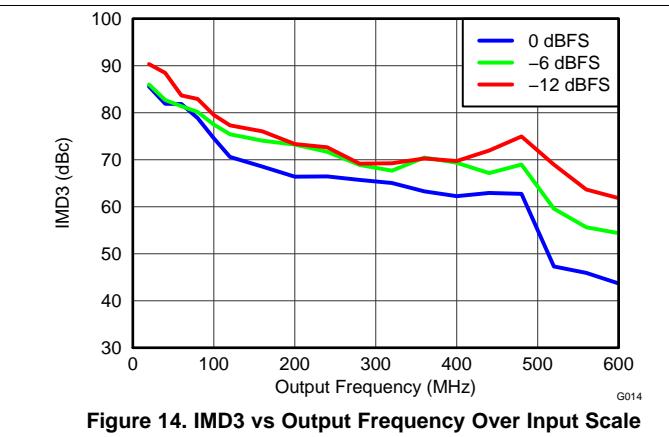
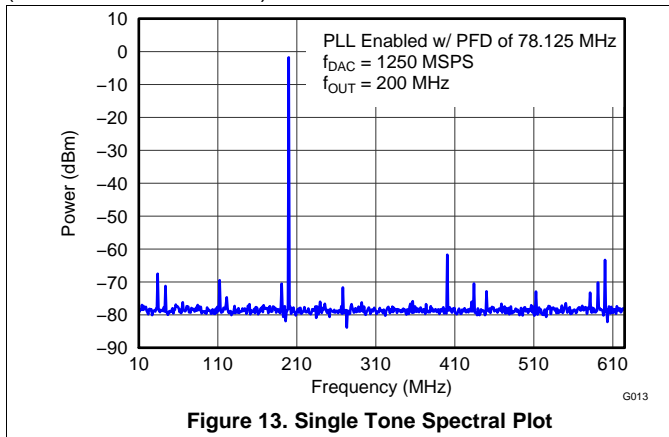

### Typical Characteristics (continued)

All plots are at 25°C, nominal supply voltage,  $f_{DAC} = 1250$  MSPS, 4x interpolation, NCO enabled, Mixer Gain disabled, QMC enabled with gain set at 1446 for both I/Q channels, 0 dBFS digital input, 20-mA full-scale output current with 4:1 transformer (unless otherwise noted)

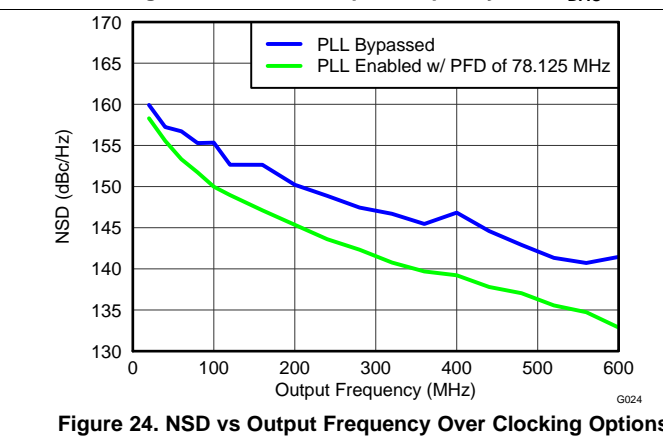
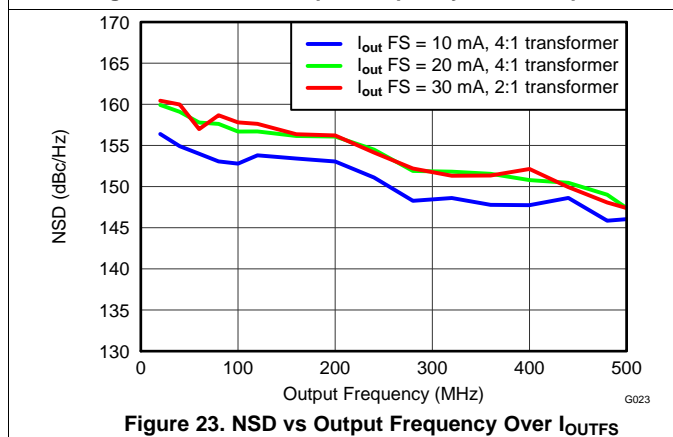
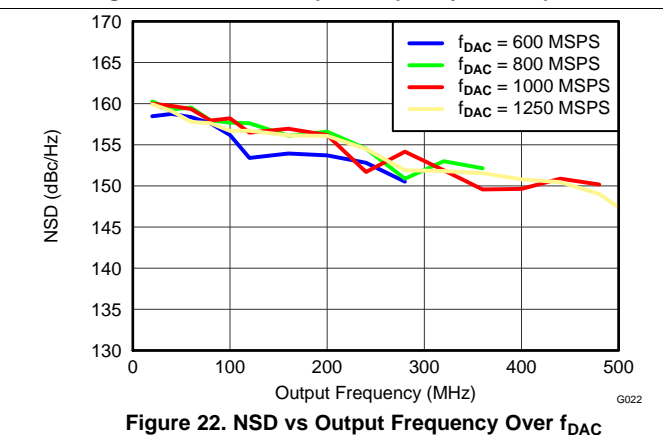
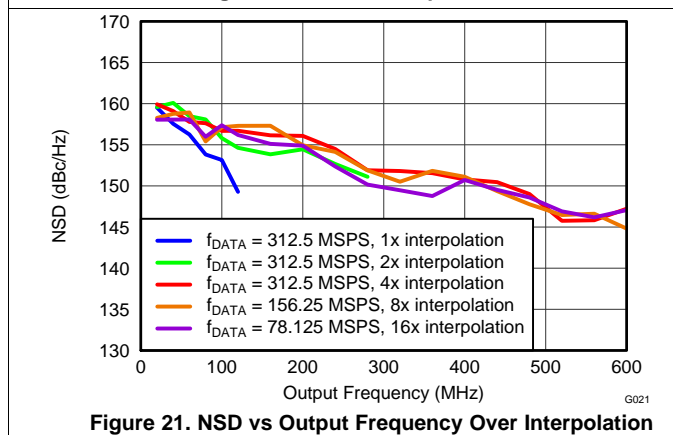
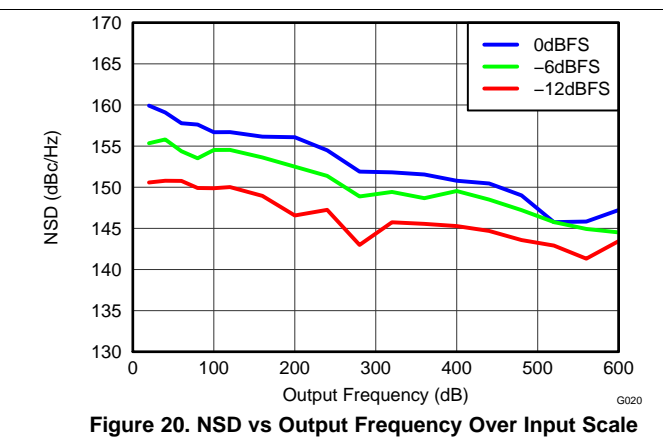
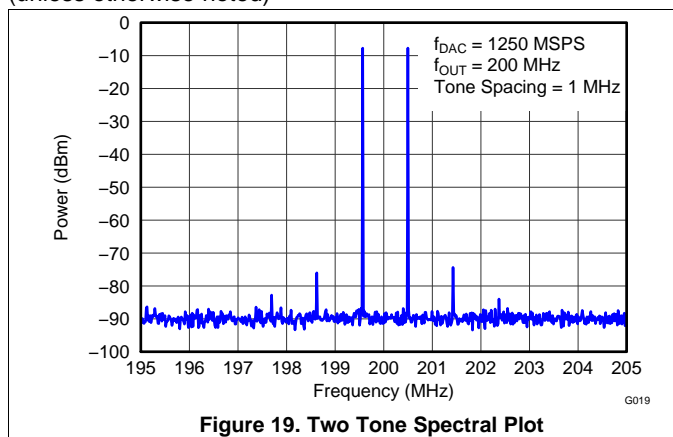

### Typical Characteristics (continued)

All plots are at 25°C, nominal supply voltage,  $f_{DAC} = 1250$  MSPS, 4x interpolation, NCO enabled, Mixer Gain disabled, QMC enabled with gain set at 1446 for both I/Q channels, 0 dBFS digital input, 20-mA full-scale output current with 4:1 transformer (unless otherwise noted)

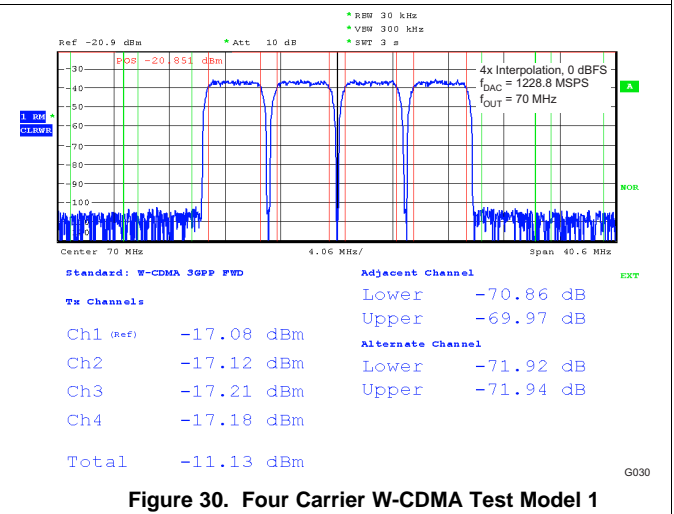
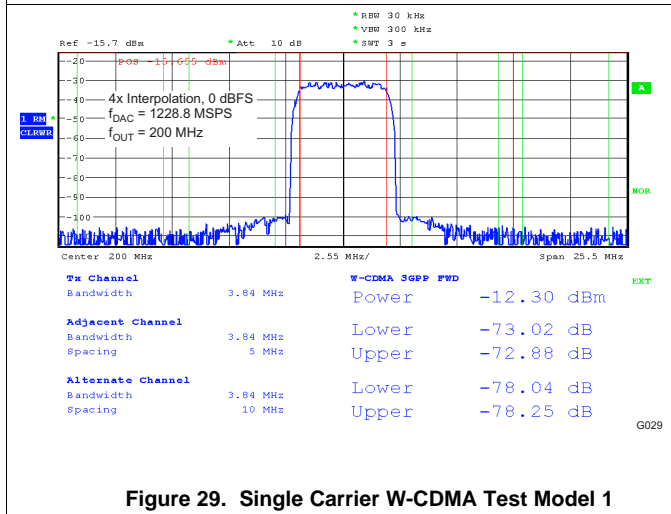
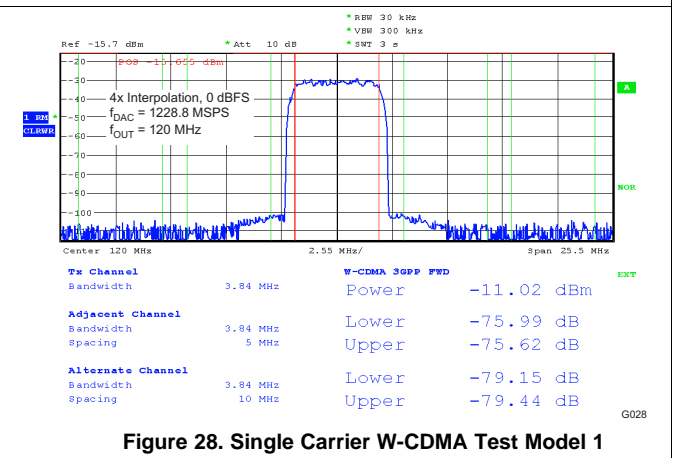
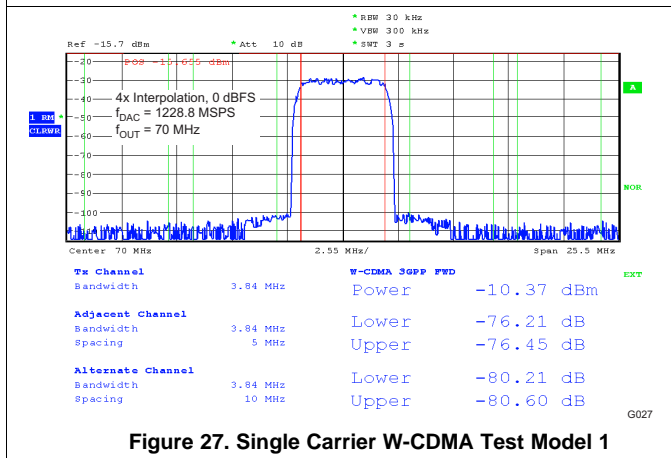
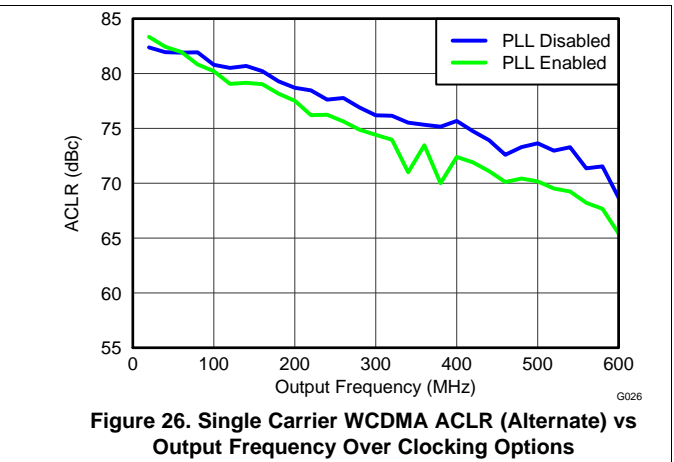
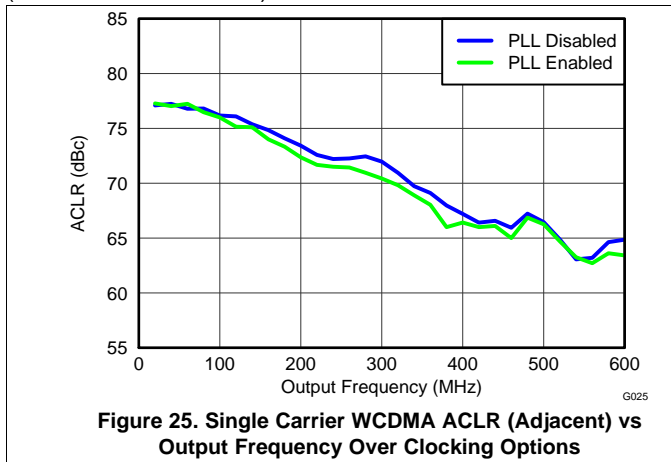

### Typical Characteristics (continued)

All plots are at 25°C, nominal supply voltage,  $f_{DAC} = 1250$  MSPS, 4x interpolation, NCO enabled, Mixer Gain disabled, QMC enabled with gain set at 1446 for both I/Q channels, 0 dBFS digital input, 20-mA full-scale output current with 4:1 transformer (unless otherwise noted)

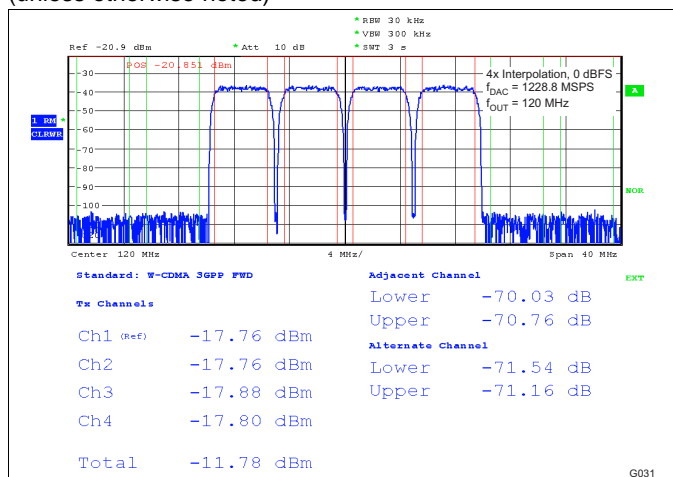

Figure 31. Four Carrier W-CDMA Test Model 1

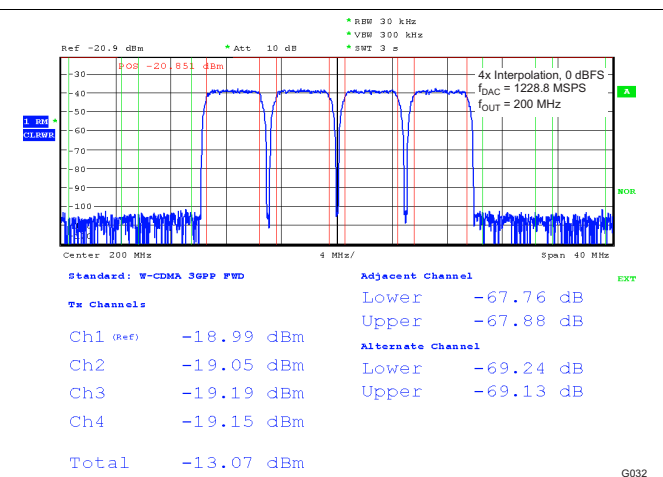

Figure 32. Four Carrier W-CDMA Test Model 1

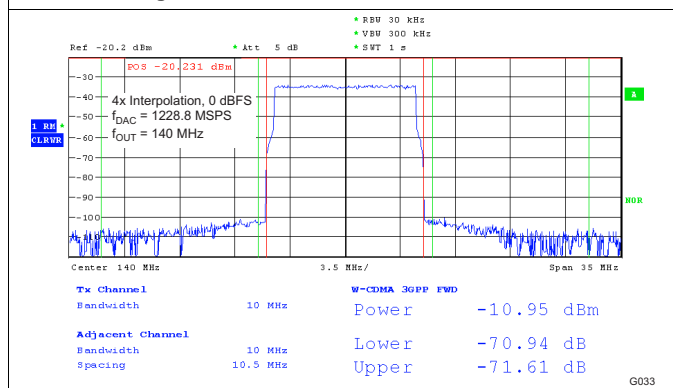

Figure 33. 10-MHz Single Carrier LTE Test Model 3.1

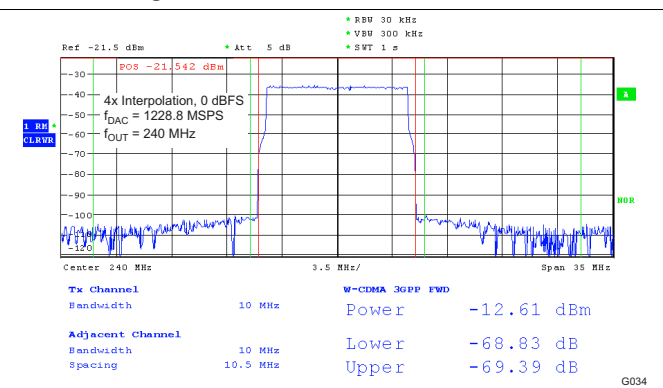

Figure 34. 10-MHz Single Carrier LTE Test Model 3.1

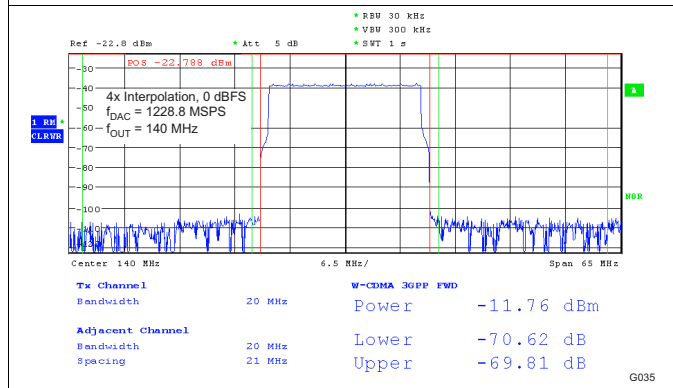

Figure 35. 20-MHz Single Carrier LTE Test Model 3.1

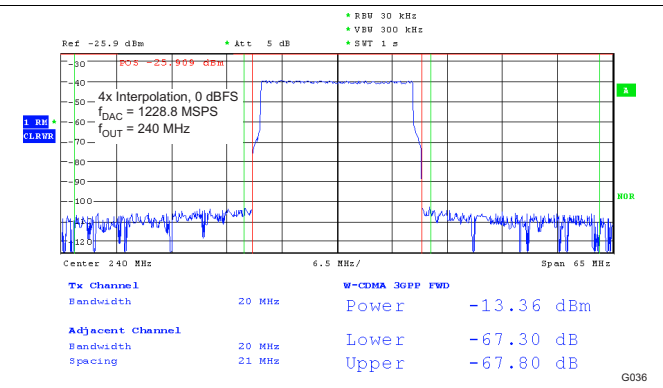
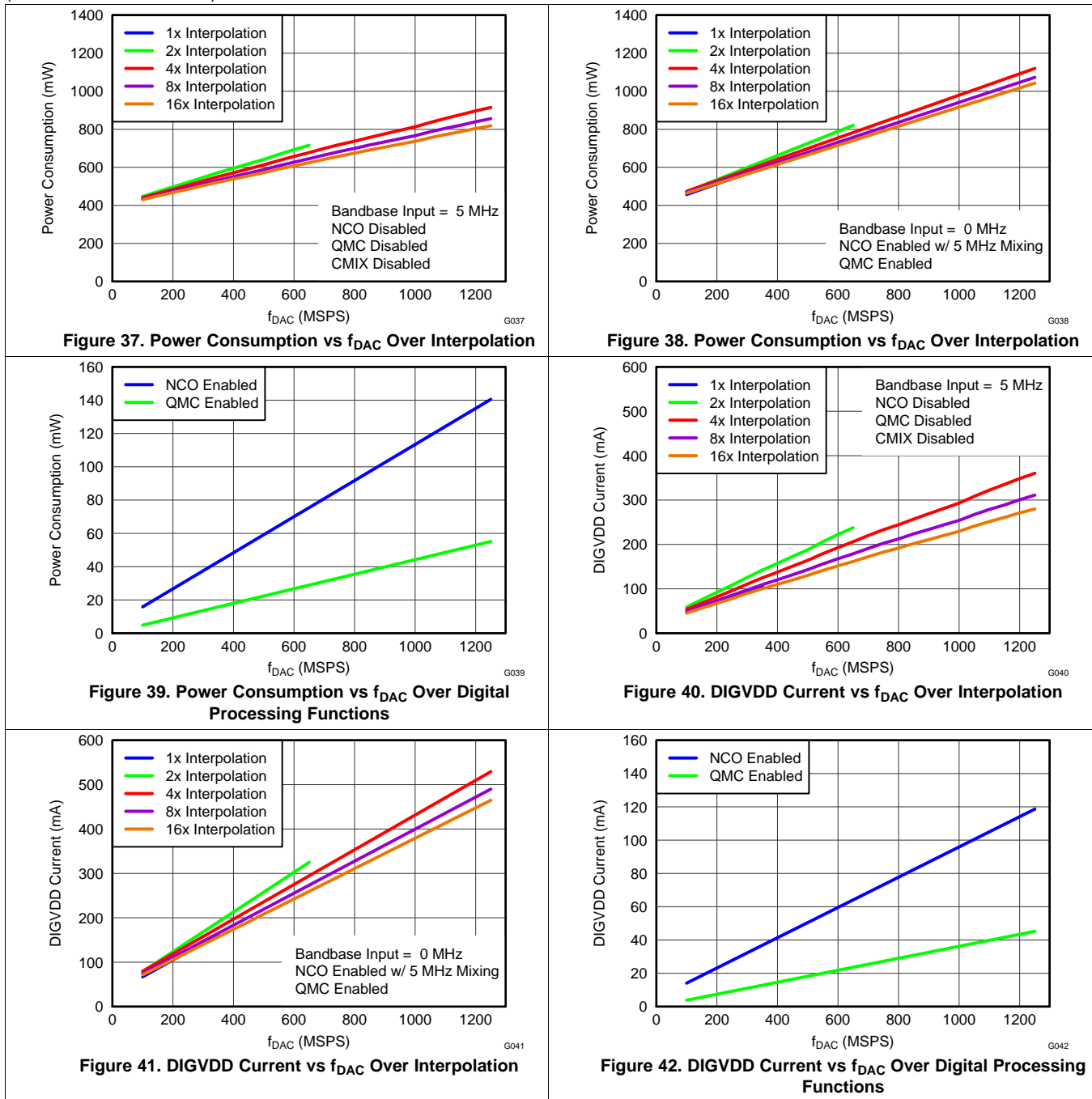

Figure 36. 20-MHz Single Carrier LTE Test Model 3.1

### Typical Characteristics (continued)

All plots are at 25°C, nominal supply voltage,  $f_{DAC} = 1250$  MSPS, 4x interpolation, NCO enabled, Mixer Gain disabled, QMC enabled with gain set at 1446 for both I/Q channels, 0 dBFS digital input, 20-mA full-scale output current with 4:1 transformer (unless otherwise noted)



Typical Characteristics (continued)

All plots are at 25°C, nominal supply voltage,  $f_{DAC} = 1250$  MSPS, 4x interpolation, NCO enabled, Mixer Gain disabled, QMC enabled with gain set at 1446 for both I/Q channels, 0 dBFS digital input, 20-mA full-scale output current with 4:1 transformer (unless otherwise noted)

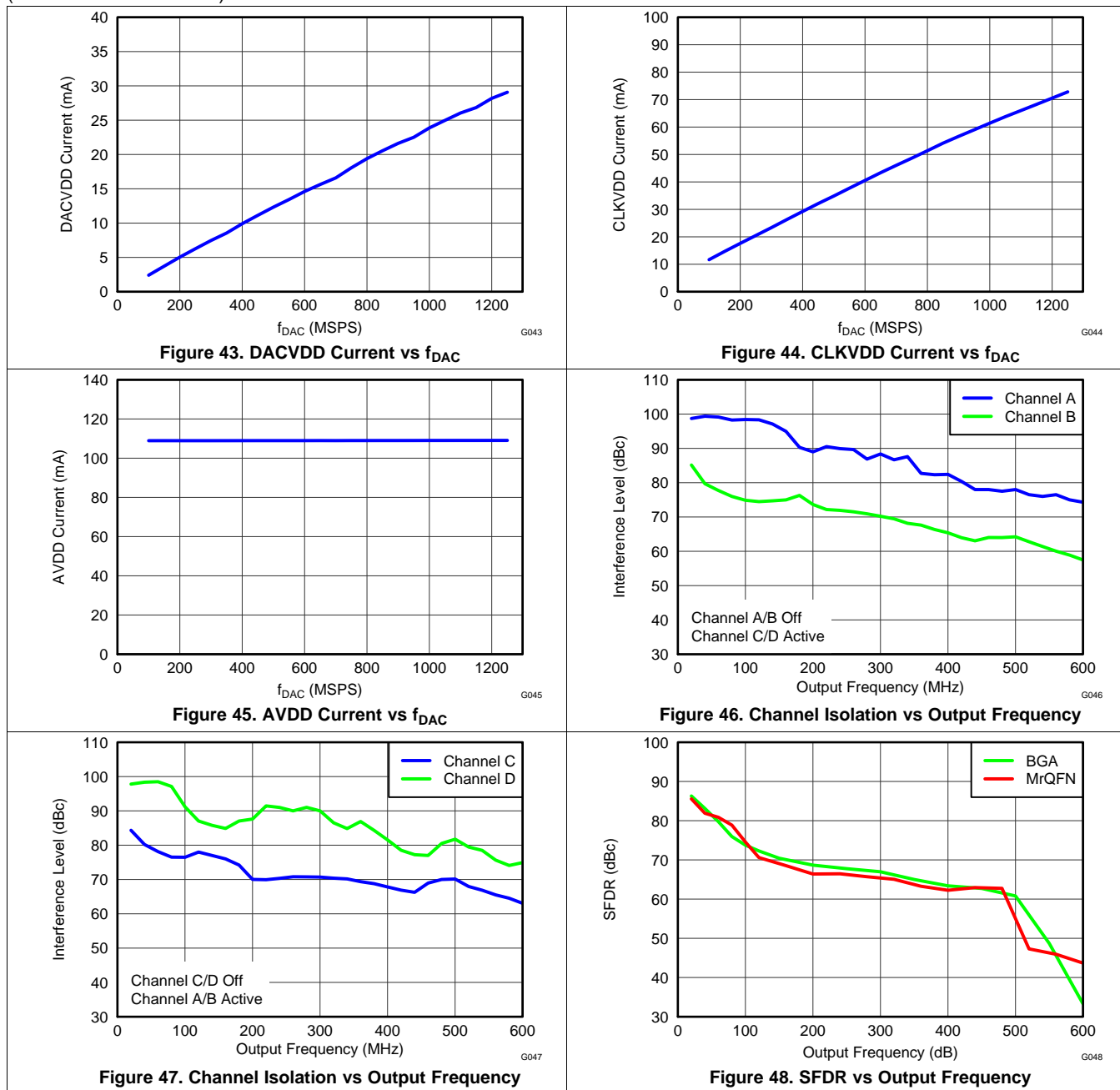

### Typical Characteristics (continued)

All plots are at 25°C, nominal supply voltage,  $f_{DAC} = 1250$  MSPS, 4x interpolation, NCO enabled, Mixer Gain disabled, QMC enabled with gain set at 1446 for both I/Q channels, 0 dBFS digital input, 20-mA full-scale output current with 4:1 transformer (unless otherwise noted)

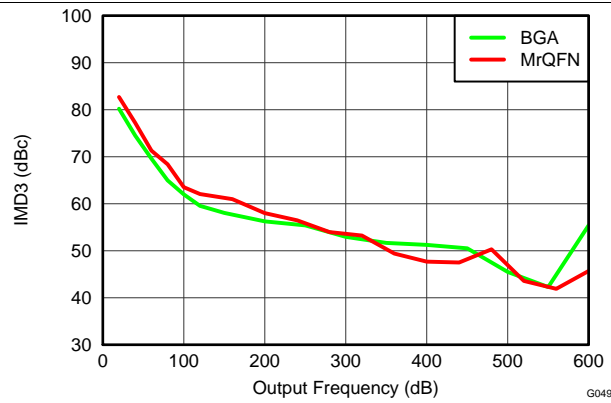

**Figure 49. IMD3 vs Output Frequency**

## 7 Detailed Description

### 7.1 Overview

The DAC3484 includes a quad-channel, 16-bit digital-to-analog converter (DAC) with up to 1.25 GSPS sample rate, a 16-bit LVDS data bus with on-chip termination, FIFO, data pattern checker, and parity test. The device includes 2x to 16x digital interpolation filters with over 90dB of stop-band attenuation, reconstruction filters, independent complex mixers, a low jitter clock multiplier, and digital Quadrature Modulator Correction (QMC).

Full synchronization of multiple devices is possible with the DAC3484. It is an ideal device for next generation communication systems.

DAC3484

SLAS749E –MARCH 2011–REVISED NOVEMBER 2015

www.ti.com

7.2 Functional Block Diagram

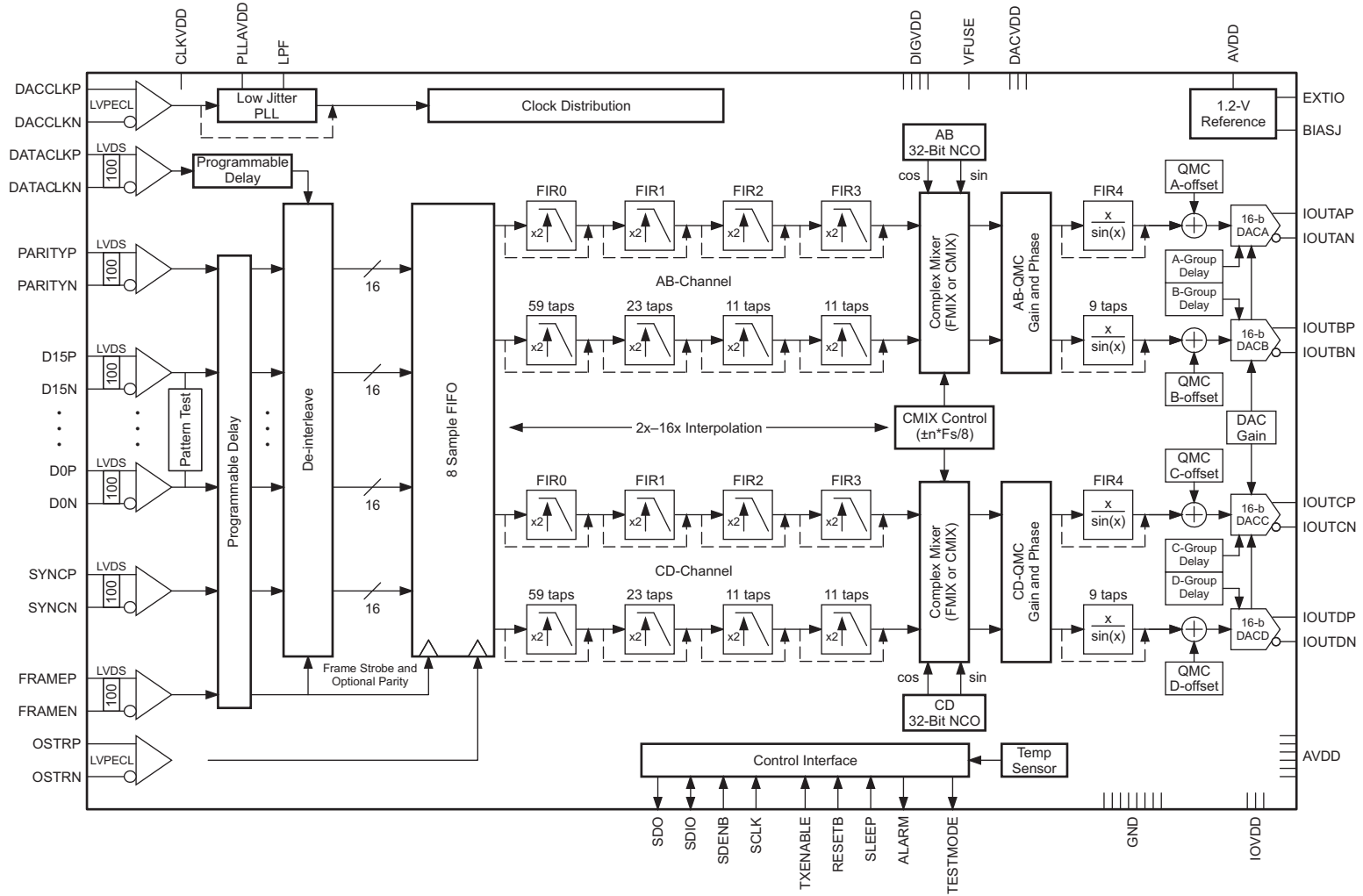

B0464-01

### 7.3 Feature Description

#### 7.3.1 Serial Interface

The serial port of the DAC3484 is a flexible serial interface which communicates with industry standard microprocessors and microcontrollers. The interface provides read/write access to all registers used to define the operating modes of DAC3484. It is compatible with most synchronous transfer formats and can be configured as a 3 or 4 pin interface by *sif4\_ena* in register *config2*. In both configurations, SCLK is the serial interface input clock and SDENB is serial interface enable. For 3 pin configuration, SDIO is a bidirectional pin for both data in and data out. For 4 pin configuration, SDIO is data in only and SDO is data out only. Data is input into the device with the rising edge of SCLK. Data is output from the device on the falling edge of SCLK.

Each read/write operation is framed by signal SDENB (Serial Data Enable Bar) asserted low. The first frame byte is the instruction cycle which identifies the following data transfer cycle as read or write as well as the 7-bit address to be accessed. Table 1 indicates the function of each bit in the instruction cycle and is followed by a detailed description of each bit. The data transfer cycle consists of two bytes.

**Table 1. Instruction Byte of the Serial Interface**

BIT	7 (MSB)	6	5	4	3	2	1	0 (LSB)
Description	R/W	A6	A5	A4	A3	A2	A1	A0

**R/W** Identifies the following data transfer cycle as a read or write operation. A high indicates a read operation from DAC3484 and a low indicates a write operation to DAC3484.

**[A6 : A0]** Identifies the address of the register to be accessed during the read or write operation.

Figure 50 shows the serial interface timing diagram for a DAC3484 write operation. SCLK is the serial interface clock input to DAC3484. Serial data enable SDENB is an active low input to DAC3484. SDIO is serial data in. Input data to DAC3484 is clocked on the rising edges of SCLK.

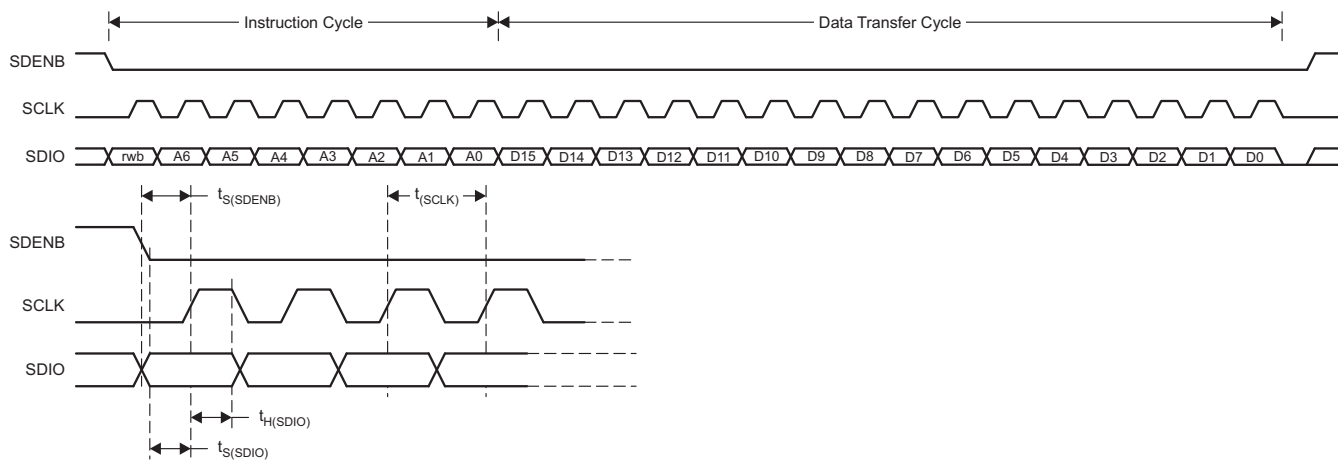

T0521-01

**Figure 50. Serial Interface Write Timing Diagram**

Figure 51 shows the serial interface timing diagram for a DAC3484 read operation. SCLK is the serial interface clock input to DAC3484. Serial data enable SDENB is an active low input to DAC3484. SDIO is serial data in during the instruction cycle. In 3 pin configuration, SDIO is data out from the DAC3484 during the data transfer cycle, while SDO is in a high-impedance state. In 4 pin configuration, SDO is data out from the DAC3484 during the data transfer cycle. At the end of the data transfer, SDIO and SDO will output low on the final falling edge of SCLK until the rising edge of SDENB when they will 3-state.

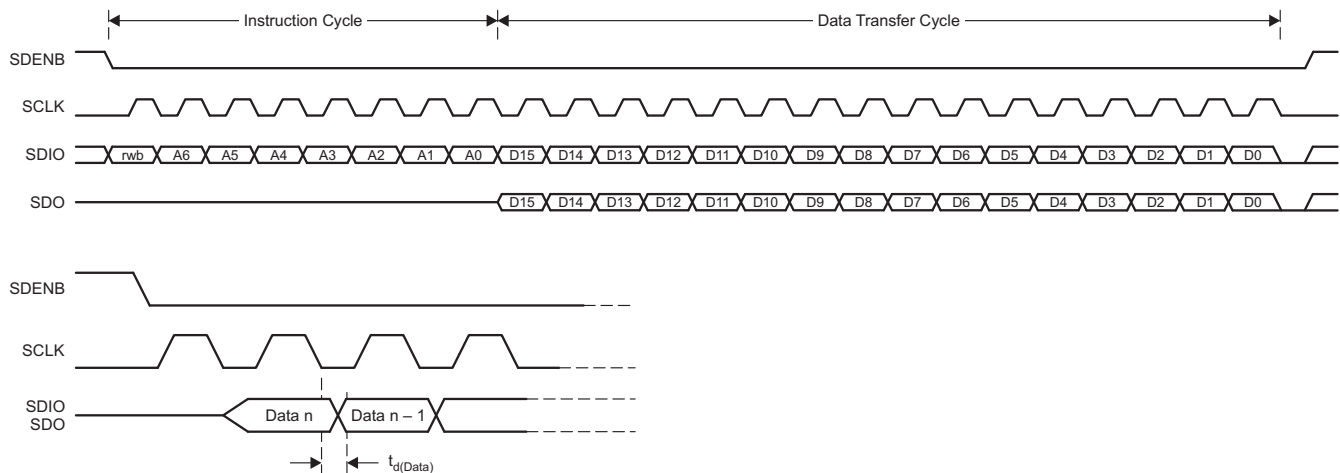

T0522-01

**Figure 51. Serial Interface Read Timing Diagram**

### 7.3.2 Data Interface

The DAC3484 has a 16-bit LVDS bus that accepts quad, 16-bit data either in word-wide or dual byte-wide formats. The quad, 16-bit data can be input to the device using either a single-bus, 16-bit interface or a dual-bus, 8-bit interface. The selection between the two modes is done through *16bit\_in* in the *config2* register. The LVDS bus inputs in each mode are shown in [Table 2](#).

**Table 2. LVDS Bus Input Assignment**

INPUT MODE	PINS
Word-wide	D[15..0] → Data for paths A, B, C and D
Byte-wide	D[15..8] → Data for paths A and B D[7..0] → Data for paths C and D

Data is sampled by the LVDS double data rate (DDR) clock DATACLK. Setup and hold requirements must be met for proper sampling.

For both input bus modes, a sync signal, either FRAME or SYNC, can sync the FIFO read and/or write pointers. In byte-wide mode the sync source is needed to establish the correct sample boundaries.

The sync signal, either FRAME or SYNC, can be either a pulse or a periodic signal where the sync period corresponds to multiples of 8 samples. FRAME or SYNC is sampled by a rising edge in DATACLK. The pulse-width  $t_{(FRAME\_SYNC)}$  needs to be at least equal to 1/2 of the DATACLK period.

For both input bus mode, the value in FRAME sampled by the next falling edge in DATACLK can be used as a block parity value. This feature is enabled by setting *frame\_parity\_ena* in register *config1* to 1b. Refer to Parity Check Test section for more detail

#### 7.3.2.1 Word-Wide Format

The single-bus, 16-bit interface is selected by setting *16bit\_in* to 1b in the *config2* register. In this mode the 16-bit data for channels A, B, C and D is input word-wide interleaved in the form  $A_0, B_0, C_0, D_0, A_1, \dots$  into the D[15:0]P/N LVDS bus. Data into the DAC3484 is formatted according to the diagram shown in [Figure 52](#) where index 0 is the data LSB and index 15 is the data MSB.

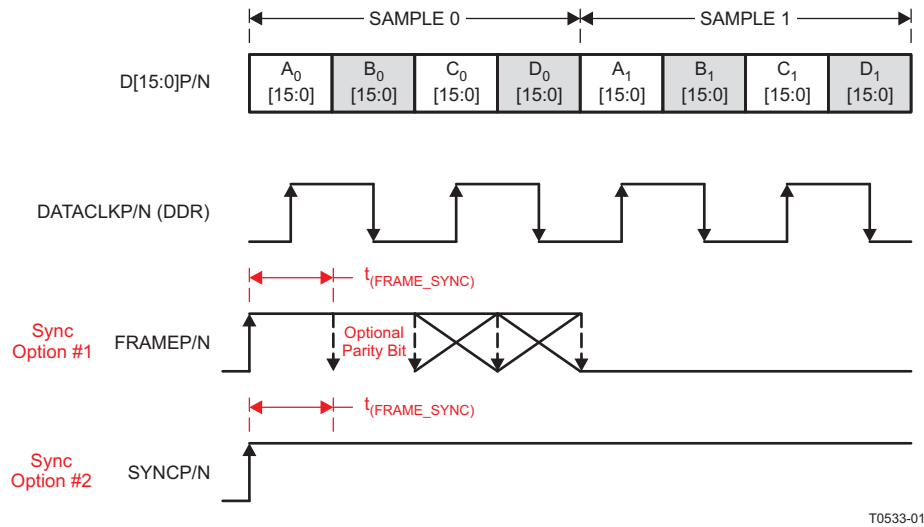

Figure 52. Word-wide Data Transmission Format

### 7.3.2.2 Byte-Wide Format

The dual-bus, 8-bit interface is selected by setting *16bit\_in* to 0b in the *config2* register. In this mode the 16-bit data for channels A and B is interleaved in the form  $A_0[15:8]$ ,  $A_0[7:0]$ ,  $B_0[15:8]$ ,  $B_0[7:0]$ ,  $A_1[15:8]$ ... into the  $D[15:8]$ P/N LVDS inputs. Similarly data for channels C and D is interleaved into the  $D[7:0]$ P/N LVDS inputs. Data into the DAC3484 is formatted according to the diagram shown in Figure 53 where index 0 is the data LSB and index 15 is the data MSB.

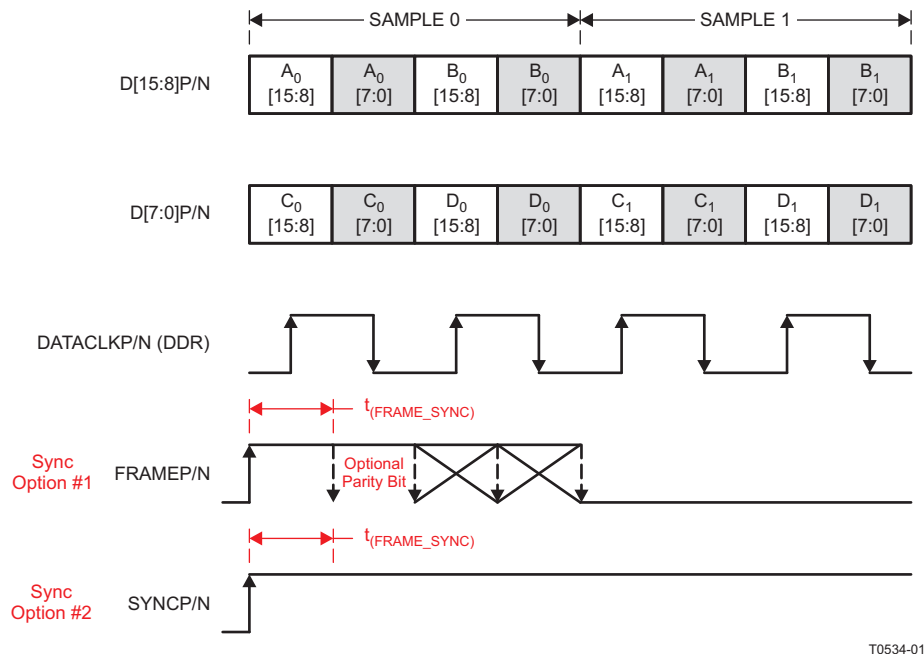
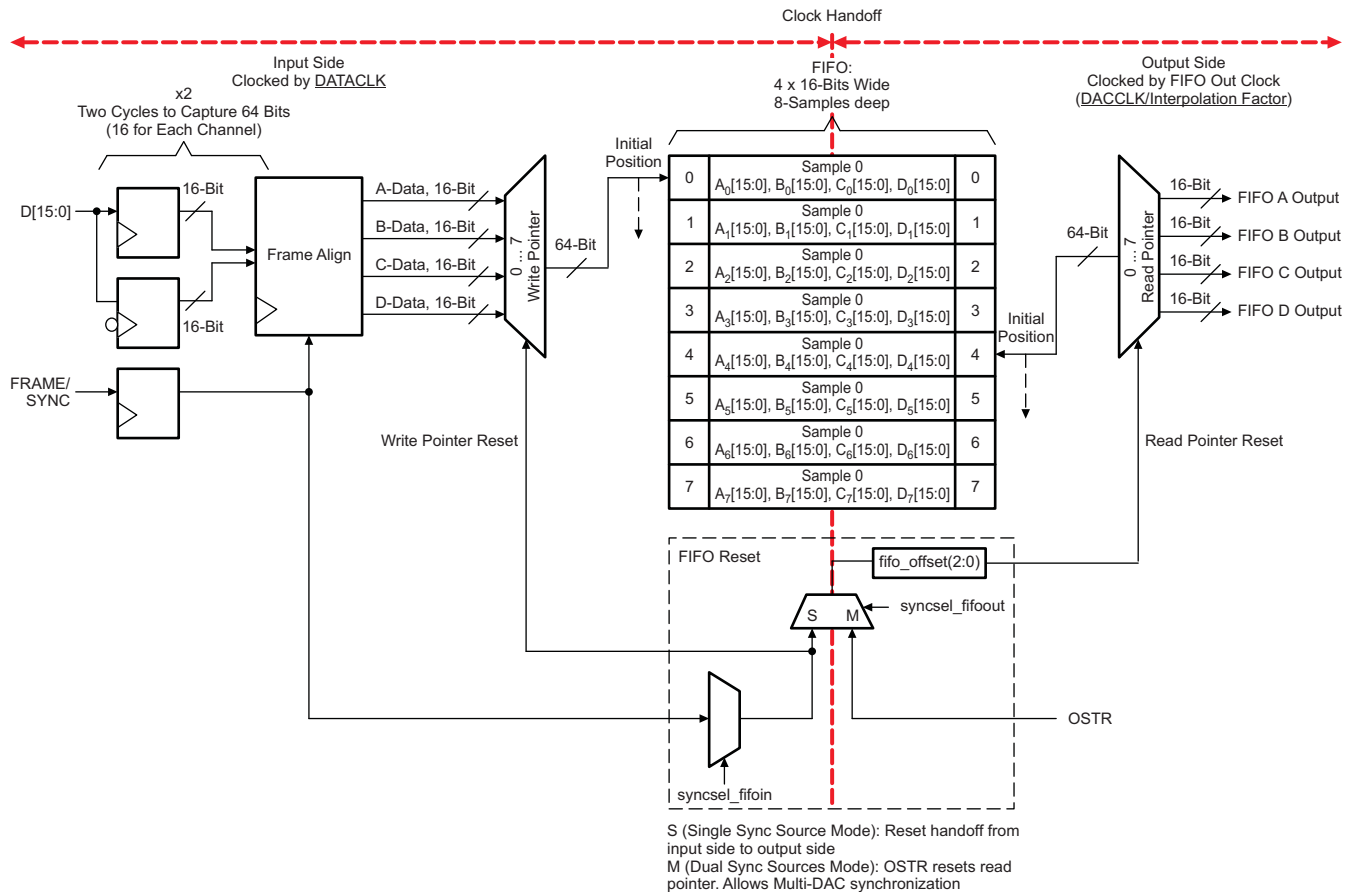

Figure 53. Byte-wide Data Transmission Format

### 7.3.3 Input FIFO

The DAC3484 includes a 4-channel, 16-bits wide, and 8-samples deep input FIFO which acts as an elastic buffer. The purpose of the FIFO is to absorb any timing variations between the input data and the internal DAC data rate clock such as the ones resulting from clock-to-data variations from the data source.

Figure 54 shows a simplified block diagram of the FIFO. The following sections provide brief overviews of the FIFO, device synchronization, and device clocking. For more details of the topics, please refer to application note SLAA584.



B0465-01

Figure 54. DAC3484 FIFO Block Diagram

Data is written to the device 16-bits at a time on the rising and falling edges of DATACLK. In order to form a complete 64-bit wide sample (16-bit A-data, 16-bit B-data, 16-bit C-data, and 16-bit D-data) two DATACLK periods are required. Each 64-bit wide sample is written into the FIFO at the address indicated by the write pointer. Similarly, data from the FIFO is read by the FIFO Out Clock 64-bits at a time from the address indicated by the read pointer. The FIFO Out Clock is generated internally from the DACCLK signal and its rate is equal to DACCLK/Interpolation. Each time a FIFO write or FIFO read is done the corresponding pointer moves to the next address.

The reset position for the FIFO read and write pointers is set by default to addresses 0 and 4 as shown in Figure 54. This offset gives optimal margin within the FIFO. The default read pointer location can be set to another value using *fifo\_offset(2:0)* in register *config9* (address 4 by default). Under normal conditions data is written-to and read-from the FIFO at the same rate and consequently the write and read pointer gap remains constant. If the FIFO write and read rates are different, the corresponding pointers will be cycling at different speeds which could result in pointer collision. Under this condition the FIFO attempts to read and write data from the same address at the same time which will result in errors and thus must be avoided.

The write pointer sync source is selected by *syncsel\_fifoin(3:0)* in register *config32*. In most applications either FRAME or SYNC are used to reset the write pointer. Unlike DATA, the sync signal is latched only on the rising edges of DATACLK. A rising edge on the sync signal source causes the pointer to return to its original position.

Similarly, the read pointer sync source is selected by *syncsel\_fifoout(3:0)*. The write pointer sync source can be set to reset the read pointer as well. In this case, FIFO Out clock will recapture the write pointer sync signal to reset the read pointer. This clock domain transfer (DATACLK to FIFO Out Clock) results in phase ambiguity of the reset signal, and will create latency variation based on the capture edge of the FIFO Out Clock. Since the reset signal also synchronizes the clock divider circuit for the FIFO Out Clock generation, the latency variation also includes the capture edge of the DACCLK cycle in the clock divider stage. Ultimately, the variation in capture edge of both the FIFO Out Clock and the DACCLK limits the precise control of the output timing latency. The full latency control of the DAC will be difficult and is not recommended in this setup.

---

**NOTE**

For full latency control of the DAC, refer to the Dual Sync Source mode section of the data sheet.

---

To alleviate this, the device offers the alternative of resetting the FIFO read pointer independently of the write pointer by using the OSTR signal. The OSTR signal is sampled by DACCLK and must satisfy the timing requirements in the specifications table. In order to minimize the skew it is recommended to use the same clock distribution device such as Texas Instruments CDCE62005 or LMK0480x family to provide the DACCLK and OSTR signals to all the DAC3484 devices in the system. Swapping the polarity of the DACCLK outputs with respect to the OSTR ones establishes proper phase relationship.

The FIFO pointers reset procedure can be done periodically or only once during initialization as the pointers automatically return to the initial position when the FIFO has been filled. To reset the FIFO periodically, it is necessary to have the FRAME, SYNC, and OSTR signals to repeat at multiples of 8 FIFO samples. To disable FIFO reset, set *syncsel\_fifoin(3:0)* and *syncsel\_fifoout(3:0)* to 0000b.

The frequency limitation for FRAME and SYNC signals are the following:

$$f_{\text{sync}} = f_{\text{DATACLK}} / (n \times 16) \text{ where } n = 1, 2, \dots \text{ for Word-Wide and Byte-Wide Mode}$$

The frequency limitation for the OSTR signal is the following:

$$f_{\text{OSTR}} = f_{\text{DAC}} / (n \times \text{interpolation} \times 8) \text{ where } n = 1, 2, \dots$$

The frequencies above are at maximum when  $n = 1$ . This is when the FRAME, SYNC, or OSTR have a rising edge transition every 8 FIFO samples. The occurrence can be made less frequent by setting  $n > 1$ , for example, every  $n \times 8$  FIFO samples.

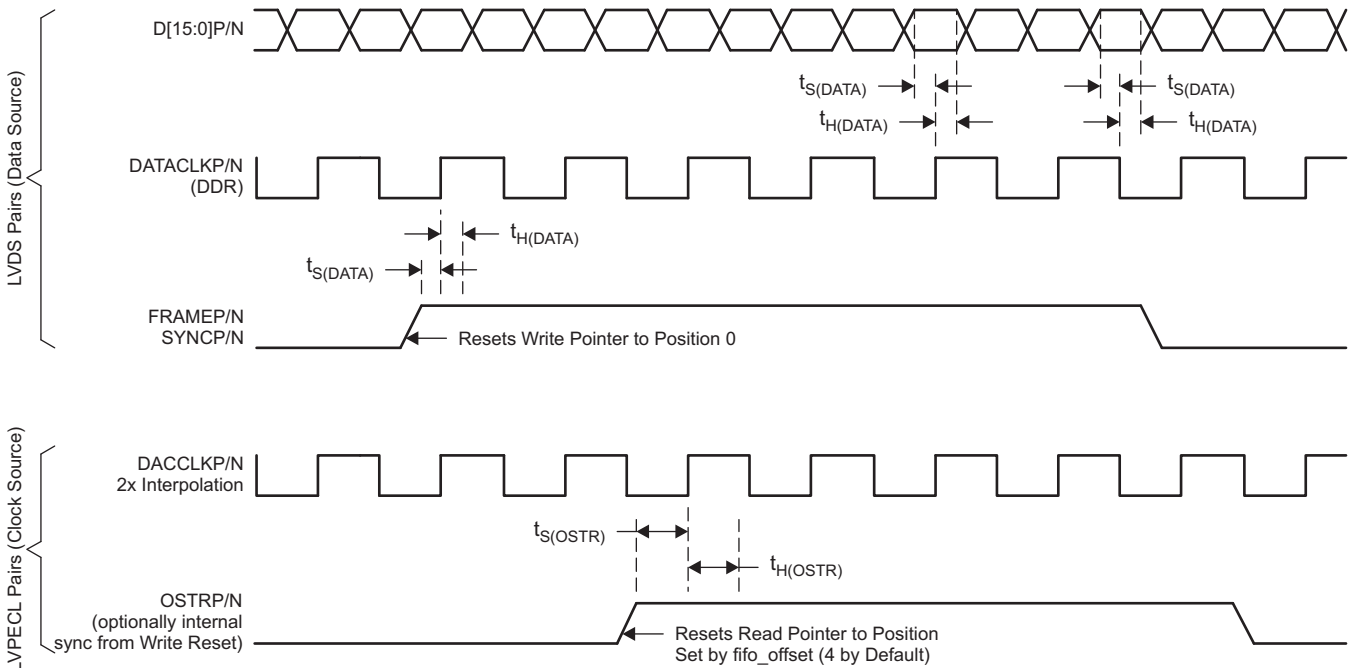

T0535-01

Figure 55. FIFO Write and Read Descriptions

### 7.3.4 FIFO Modes of Operation

The DAC3484 input FIFO can be completely bypassed through registers *config0* and *config32*. The register configuration for each mode is described in [Table 3](#).

Register	Control Bits
config0	fifo_ena
config32	syncsel_fifoout(3:0)

Table 3. FIFO Operation Modes

FIFO MODE	config0 and config32 FIFO Bits				
	fifo_ena	syncsel_fifoout			
		BIT 3: sif_sync	BIT 2: OSTR	BIT 1: FRAME	BIT 0: SYNC
Dual Sync Sources	1	0	1	0	0
Single Sync Source	1	0	0	1 or 0 Depends on the sync source	1 or 0 Depends on the sync source
Bypass	0	X	X	X	X

#### 7.3.4.1 Dual Sync Sources Mode

This is the recommended mode of operation for those applications that require precise control of the output timing. In Dual Sync Sources mode, the FIFO write and read pointers are reset independently. The FIFO write pointer is reset using the LVDS FRAME or SYNC signal, and the FIFO read pointer is reset using the LVPECL OSTR signal. This allows LVPECL OSTR signal to control the phase of the output for either a single chip or multiple chips. Multiple devices can be fully synchronized in this mode.

### 7.3.4.2 Single Sync Source Mode

In Single Sync Source mode, the FIFO write and read pointers are reset from the same source, either LVDS FRAME or LVDS SYNC signal. As described in the Input FIFO section, this mode has latency variations in both the FIFO Out Clock and DAC Clock between the multiple DAC devices. Applications requiring exact output timing control will need Dual Sync Sources mode instead of Single Sync Source Mode. A rising edge for FIFO and clock divider sync is recommended. Periodic sync signal is not recommended due to non-deterministic latency of the sync signal through the clock domain transfer.

### 7.3.4.3 Bypass Mode

In FIFO bypass mode, the FIFO block is not used. As a result the input data is handed off from the DATACLK to the DACCLK domain without any compensation. In this mode the relationship between DATACLK and DACCLK is critical and used as a synchronizing mechanism for the internal logic. Due to this constraint this mode is *not recommended*. The effects of bypassing the FIFO are the following:

- The FIFO pointers have no effect on the data path or handoff.
- The FIFO will not be able to pass the controls signals from the LVDS FRAME and LVDS SYNC to digital circuits after the FIFO. These digital circuits mainly are quadrature modulation corrections circuits, complex mixer circuits, and numerical controlled oscillator circuits.

### 7.3.5 Clocking Modes

The DAC3484 has a dual clock setup in which a DAC clock signal is used to clock the DAC cores and internal digital logic and a separate DATA clock is used to clock the input LVDS receivers and FIFO input. The DAC3484 DAC clock signal can be sourced directly or generated through an on-chip low-jitter phase-locked loop (PLL).

In those applications requiring extremely low noise it is recommended to bypass the PLL and source the DAC clock directly from a high-quality external clock to the DACCLK input. In most applications system clocking can be simplified by using the on-chip PLL to generate the DAC core clock while still satisfying performance requirements. In this case the DACCLK pins are used as the reference frequency input to the PLL.

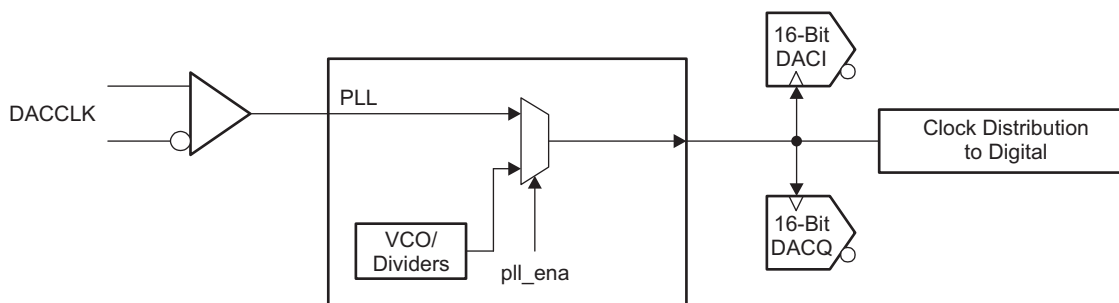

Figure 56. Top Level Clock Diagram

#### 7.3.5.1 PLL Bypass Mode

In PLL bypass mode a very high quality clock is sourced to the DACCLK inputs. This clock is used to directly clock the DAC3484 DAC sample rate clock. This mode gives the device best performance and is recommended for extremely demanding applications.

The bypass mode is selected by setting the following:

1. *pll\_ena* bit in register *config24* to 0b to bypass the PLL circuitry.
2. *pll\_sleep* bit in register *config26* to 1b to put the PLL and VCO into sleep mode.

#### 7.3.5.2 PLL Mode

In this mode the clock at the DACCLK input functions as a reference clock source to the on-chip PLL. The on-chip PLL will then multiply this reference clock to supply a higher frequency DAC sample rate clock. Figure 57 shows the block diagram of the PLL circuit.

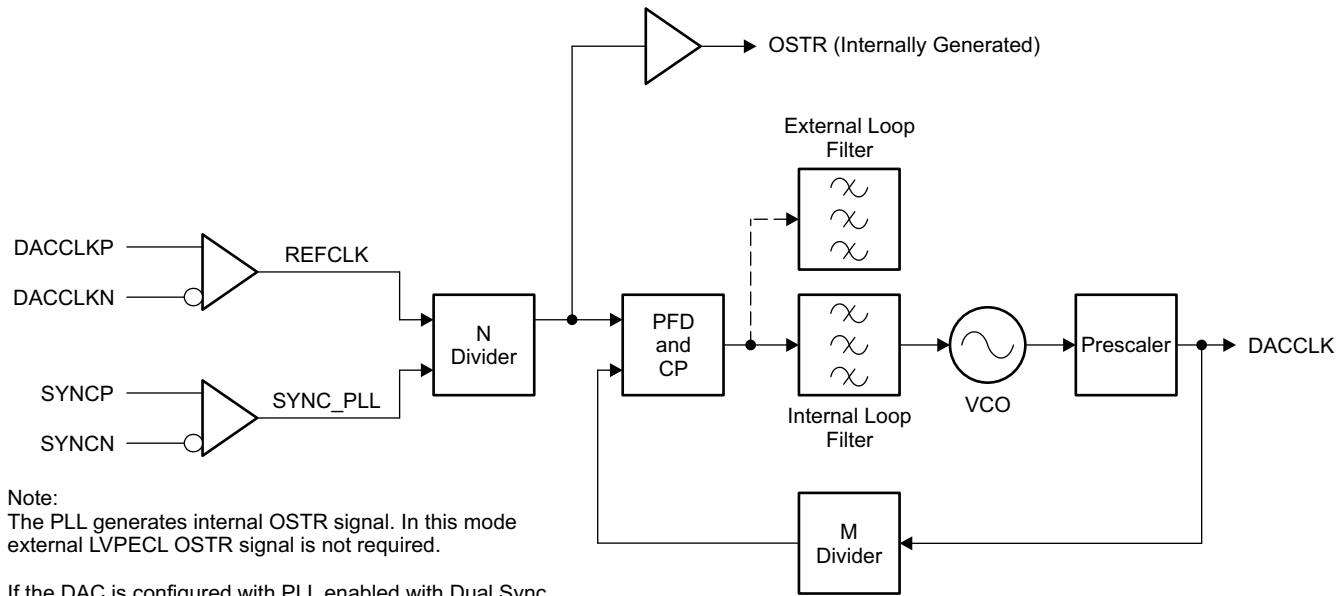

Note:  
The PLL generates internal OSTR signal. In this mode external LVPECL OSTR signal is not required.

If the DAC is configured with PLL enabled with Dual Sync Sources mode, then the PFD frequency has to be the pre-defined OSTR frequency.

B0453-01

Figure 57. PLL Block Diagram

The DAC3484 PLL mode is selected by setting the following:

1. *pll\_ena* bit in register *config24* to 1b to route to the PLL clock path.
2. *pll\_sleep* bit in register *config26* to 0b to enable the PLL and VCO.

The output frequency of the VCO is designed to be in the range from 3.3GHz to 4.0GHz. The prescaler value, *pll\_p(2:0)* in register *config24*, should be chosen such that the product of the prescaler value and DAC sample rate clock is within the VCO range. To maintain optimal PLL loop, the coarse tune bits, *pll\_vco(5:0)* in register *config26*, can adjust the center frequency of the VCO towards the product of the prescaler value and DAC sample rate clock. Figure 58 shows a typical relationship between coarse tune bits and VCO center frequency.

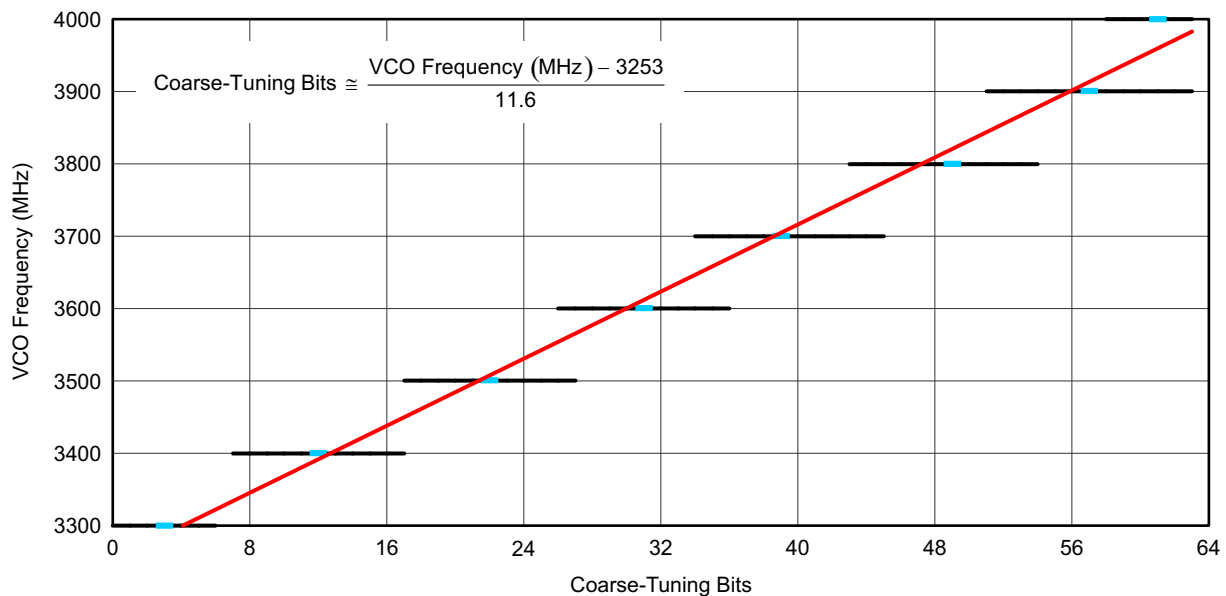

Figure 58. Typical PLL/VCO Lock Range vs Coarse Tuning Bits

Common wireless infrastructure frequencies (614.4 MHz, 737.28 MHz, 1.2288 GHz, ...) are generated from this VCO frequency in conjunction with the pre-scaler setting as shown in [Table 4](#).

**Table 4. VCO Operation**

VCO FREQUENCY (MHz)	PRE-SCALE DIVIDER	DESIRED DACCLK (MHz)	pll_p(2:0)
3440.64	7	491.52	111
3686.4	6	614.4	110
3686.4	5	737.28	101
3686.4	3	1228.8	011

The M divider is used to determine the phase-frequency-detector (PFD) and charge-pump (CP) frequency.

**Table 5. PFD and CP Operation**

DACCLK FREQUENCY (MHz)	M DIVIDER	PDF UPDATE RATE (MHz)	pll_m(7:0)
491.52	4	122.88	00000100
491.52	8	61.44	00001000
491.52	16	30.72	00010000
491.52	32	15.36	00100000

The N divider in the loop allows the PFD to operate at a lower frequency than the reference clock. Both M and N dividers can keep the PFD frequency below 155 MHz for peak operation.

The overall divide ratio inside the loop is the product of the Pre-Scale and M dividers ( $P * M$ ) and the following guidelines should be followed:

- The overall divide ratio range is from 24 to 480
- When the overall divide ratio is less than 120, the internal loop filter can guarantee a stable loop
- When the overall divide ratio is greater than 120, an external loop filter or double charge pump is required to ensure loop stability

The single- and double-charge-pump current option are selected by setting *pll\_cp* in register *config24* to 01b and 11b, respectively. When using the double-charge-pump setting, an external loop filter is not required. If an external filter is required, the following filter should be connected to the LPF pin (A1 for RKD package and D12 for ZAY package):

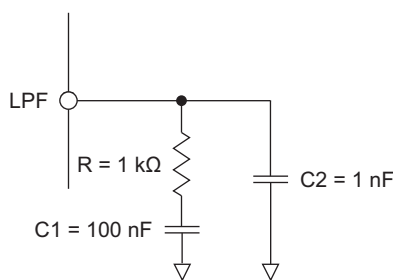

S0514-01

**Figure 59. Recommended External Loop Filter**

The PLL generates an internal OSTR signal and does not require the external LVPECL OSTR signal. The OSTR signal is buffered from the N-divider output in the PLL block, and the frequency of the signal is the same as the PFD frequency. Therefore, using PLL with Dual Sync Sources mode would require the PFD frequency to be the pre-defined OSTR frequency. This will allow the FIFO to be synced correctly by the internal OSTR.

### 7.3.6 FIR Filters

Figure 60 through Figure 63 show the magnitude spectrum response for the FIR0, FIR1, FIR2 and FIR3 interpolating filters where  $f_{IN}$  is the input data rate to the FIR filter. Figure 64 to Figure 67 show the composite filter response for 2x, 4x, 8x and 16x interpolation. The transition band for all interpolation settings is from 0.4 to  $0.6 \times f_{DATA}$  (the input data rate to the device) with  $<0.001\text{dB}$  of pass-band ripple and  $>90\text{dB}$  stop-band attenuation.

The DAC3484 also has a 9-tap inverse sinc filter (FIR4) that runs at the DAC update rate ( $f_{DAC}$ ) that can be used to flatten the frequency response of the sample-and-hold output. The DAC sample-and-hold output sets the output current and holds it constant for one DAC clock cycle until the next sample, resulting in the well-known  $\sin(x)/x$  or  $\text{sinc}(x)$  frequency response (Figure 68, red line). The inverse sinc filter response (Figure 68, blue line) has the opposite frequency response from 0 to  $0.4 \times f_{DAC}$ , resulting in the combined response (Figure 68, green line). Between 0 to  $0.4 \times f_{DAC}$ , the inverse sinc filter compensates the sample-and-hold roll-off with less than 0.03dB error.

The inverse sinc filter has a gain  $>1$  at all frequencies. Therefore, the signal input to FIR4 must be reduced from full scale to prevent saturation in the filter. The amount of back-off required depends on the signal frequency, and is set such that at the signal frequencies the combination of the input signal and filter response is less than 1 (0dB). For example, if the signal input to FIR4 is at  $0.25 \times f_{DAC}$ , the response of FIR4 is 0.9dB, and the signal must be backed off from full scale by 0.9dB to avoid saturation. The gain function in the QMC blocks can be used to reduce the amplitude of the input signal. The advantage of FIR4 having a positive gain at all frequencies is that the user is then able to optimize the back-off of the signal based on its frequency.

The filter taps for all digital filters are listed in Table 6. Note that the loss of signal amplitude may result in lower SNR due to decrease in signal amplitude.

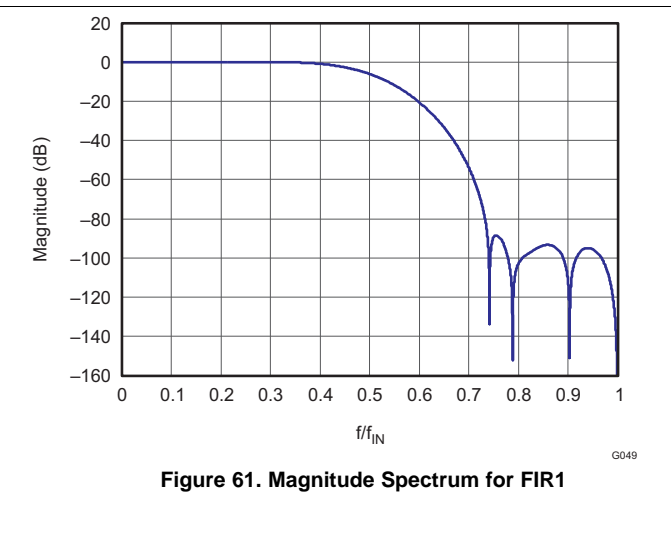
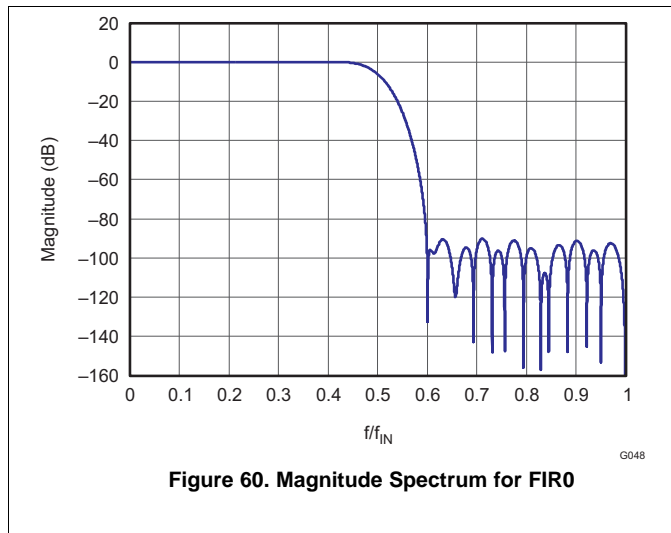

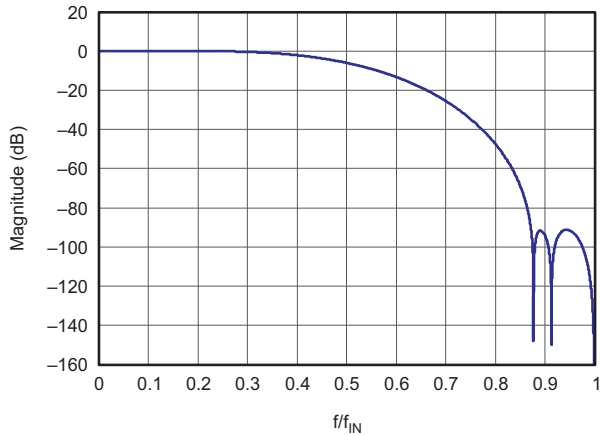

**Figure 62. Magnitude Spectrum for FIR2**

G050

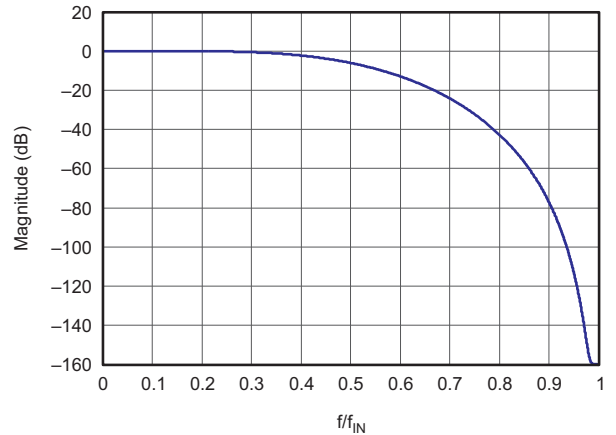

**Figure 63. Magnitude Spectrum for FIR3**

G051

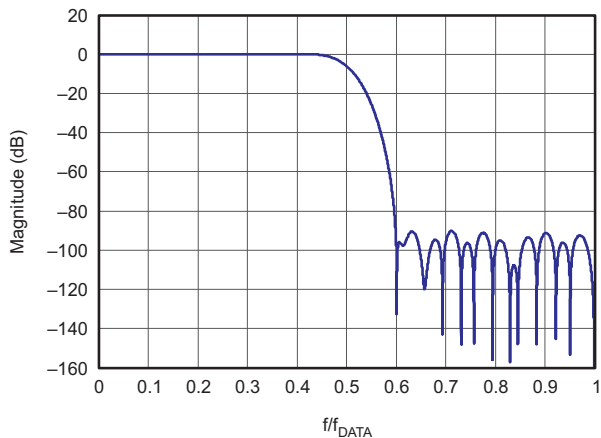

**Figure 64. 2x Interpolation Composite Response**

G052

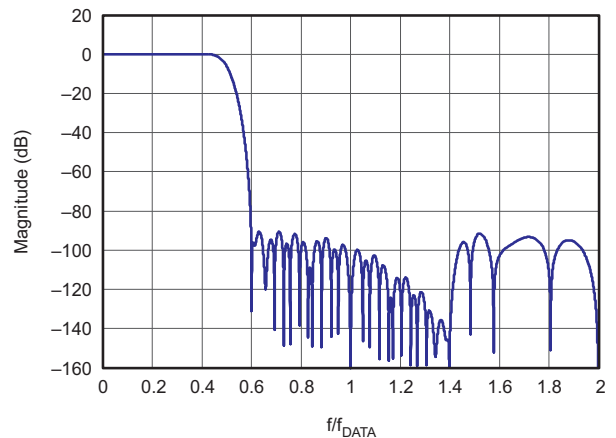

**Figure 65. 4x Interpolation Composite Response**

G053

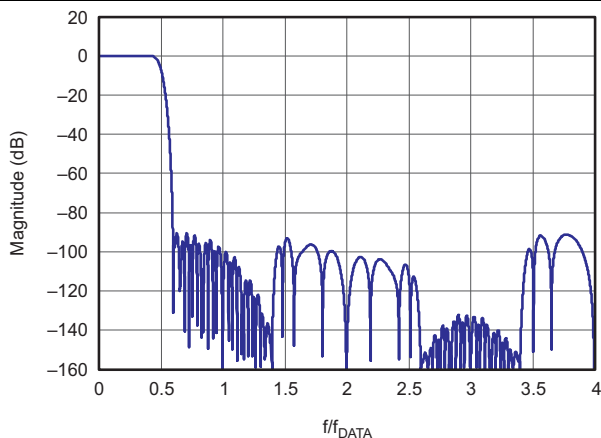

**Figure 66. 8x Interpolation Composite Response**

G054

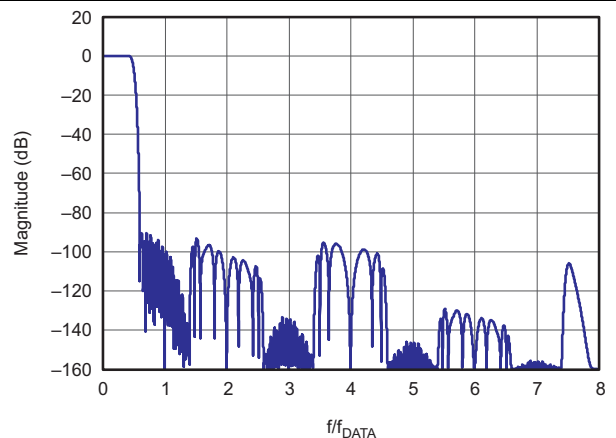

**Figure 67. 16x Interpolation Composite Response**

G055

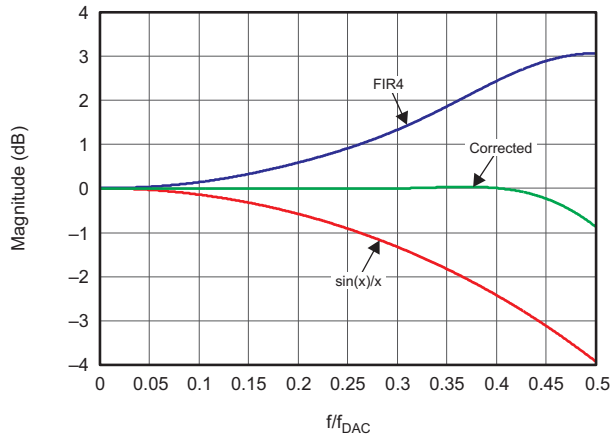

**Figure 68. Magnitude Spectrum for Inverse Sinc Filter**

**Table 6. FIR Filter Coefficients**

INTERPOLATING HALF-BAND FILTERS								NON-INTERPOLATING INVERSE-SINC FILTER	
FIR0		FIR1		FIR2		FIR3		FIR4	
59 TAPS		23 TAPS		11 TAPS		11 TAPS		9 TAPS	
6	6	-12	-12	29	29	3	3	1	1
0	0	0	0	0	0	0	0	-4	-4
-19	-19	84	84	-214	-214	-25	-25	13	13
0	0	0	0	0	0	0	0	-50	-50
47	47	-336	-336	1209	1209	150	150	<b>592<sup>(1)</sup></b>	
0	0	0	0	<b>2048<sup>(1)</sup></b>		<b>256<sup>(1)</sup></b>			
-100	-100	1006	1006						
0	0	0	0						
192	192	-2691	-2691						
0	0	0	0						
-342	-342	10141	10141						
0	0	<b>16384<sup>(1)</sup></b>							
572	572								
0	0								
-914	-914								
0	0								
1409	1409								
0	0								
-2119	-2119								
0	0								
3152	3152								
0	0								
-4729	-4729								
0	0								
7420	7420								
0	0								
-13334	-13334								
0	0								
41527	41527								
<b>65536<sup>(1)</sup></b>									

(1) Center taps are highlighted in BOLD

### 7.3.7 Complex Signal Mixer

The DAC3484 has two paths of complex signal mixer blocks that contain two full complex mixer (FMIX) blocks and power saving coarse mixer (CMIX) blocks. The signal path is shown in Figure 69.

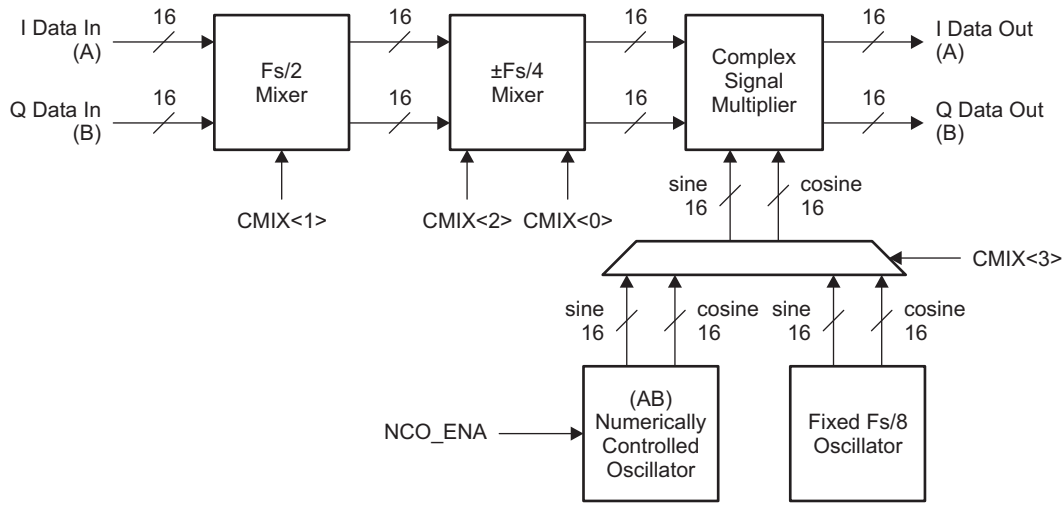

B0471-02

Figure 69. Path of Complex Signal Mixer

#### 7.3.7.1 Full Complex Mixer

The two FMIX blocks operate with independent Numerically Controlled Oscillators (NCOs) and enable flexible frequency placement without imposing additional limitations in the signal bandwidth. The NCOs have 32-bit frequency registers (*phaseaddAB(31:0)* and *phaseaddCD(31:0)*) and 16-bit phase registers (*phaseoffsetAB(15:0)* and *phaseoffsetCD(15:0)*) that generate the sine and cosine terms for the complex mixing. The NCO block diagram is shown in Figure 70.

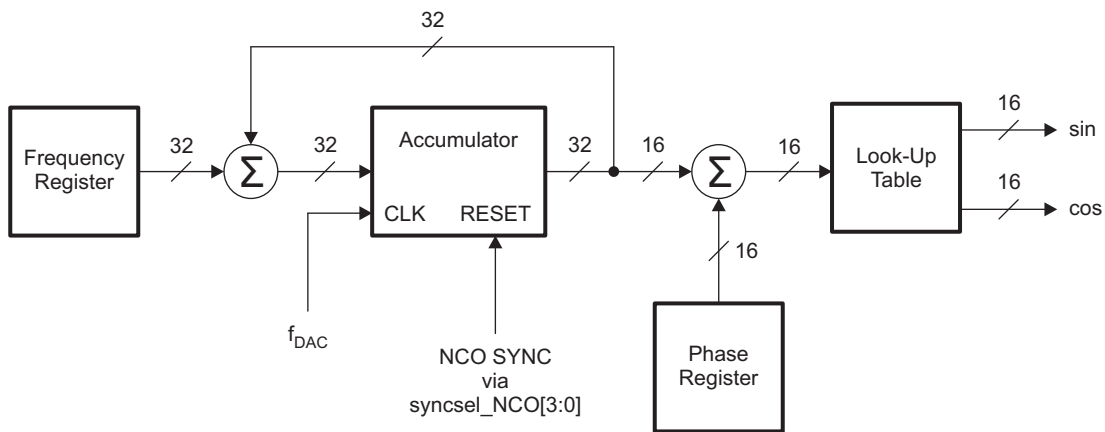

B0026-03

Figure 70. NCO Block Diagram

Synchronization of the NCOs occurs by resetting the NCO accumulators to zero. The synchronization source is selected by *syncsel\_NCO(3:0)* in *config31*. The frequency word in the *phaseaddAB(31:0)* and *phaseaddCD(31:0)* registers is added to the accumulators every clock cycle,  $f_{DAC}$ . The output frequency of the NCO is:

$$f_{NCO} = \frac{freq \times f_{NCO\_CLK}}{2^{32}} \tag{1}$$

With the complex mixer enabled, the two channels in the mixer path are treated as complex vectors of the form  $I_{IN}(t) + j Q_{IN}(t)$ . The complex signal multiplier (shown in Figure 71) will multiply the complex channels with the sine and cosine terms generated by the NCO. The resulting output,  $I_{OUT}(t) + j Q_{OUT}(t)$ , of the complex signal multiplier is:

$$I_{OUT}(t) = (I_{IN}(t)\cos(2\pi f_{NCO}t + \delta) - Q_{IN}(t)\sin(2\pi f_{NCO}t + \delta)) \times 2^{(mixer\_gain - 1)}$$

$$Q_{OUT}(t) = (I_{IN}(t)\sin(2\pi f_{NCO}t + \delta) + Q_{IN}(t)\cos(2\pi f_{NCO}t + \delta)) \times 2^{(mixer\_gain - 1)}$$

where  $t$  is the time since the last resetting of the NCO accumulator,  $\delta$  is the phase offset value and  $mixer\_gain$  is either 0 or 1.  $\delta$  is given by:

$$\delta = 2\pi \times phase\_offsetAB/CD(15:0)/2^{16}$$

The  $mixer\_gain$  option allows the output signals of the multiplier to reduce by half (6dB). See Mixer Gain section for details.

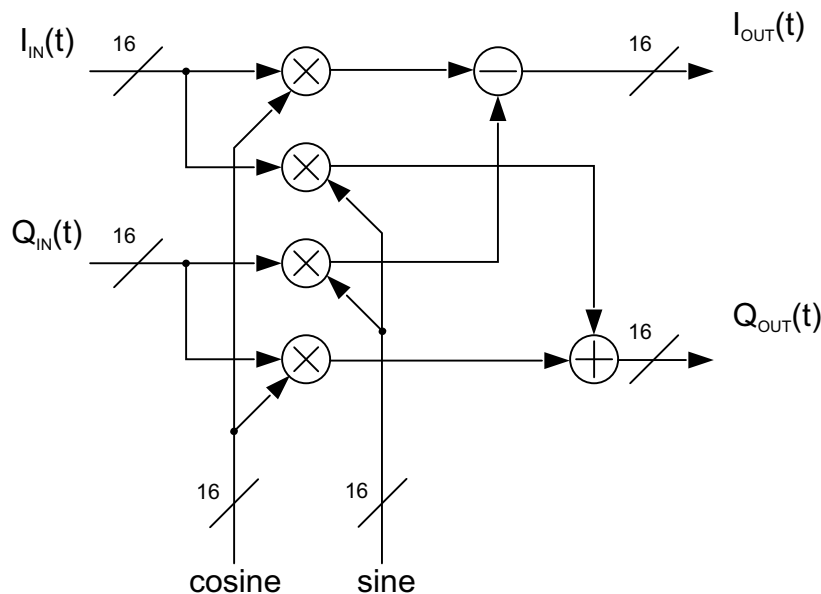

**Figure 71. Complex Signal Multiplier**

**7.3.7.2 Coarse Complex Mixer**

In addition to the full complex mixer, the DAC3484 also has a coarse mixer block capable of shifting the input signal spectrum by the fixed mixing frequencies  $\pm n \times f_s/8$ . Using the coarse mixer instead of the full mixer lowers power consumption.

The output of the  $f_s/2$ ,  $f_s/4$ , and  $-f_s/4$  mixer block is:

$$I_{OUT}(t) = I(t)\cos(2\pi f_{CMIX}t) - Q(t)\sin(2\pi f_{CMIX}t)$$

$$Q_{OUT}(t) = I(t)\sin(2\pi f_{CMIX}t) + Q(t)\cos(2\pi f_{CMIX}t)$$

Since the sine and the cosine terms are a function of  $f_s/2$ ,  $f_s/4$ , or  $-f_s/4$  mixing frequencies, the possible resulting value of the terms will only be 1, -1, or 0. The simplified mathematics allows the complex signal multiplier to be bypassed in any one of the modes, thus mixer gain is not available. The  $f_s/2$ ,  $f_s/4$ , and  $-f_s/4$  mixer blocks performs mixing through negating and swapping of I/Q channel on certain sequence of samples. Table 7 shows the algorithm used for those mixer blocks.

**Table 7. Fs/2, Fs/4, and -Fs/4 Mixing Sequence**

MODE	MIXING SEQUENCE
Normal (mixer bypassed)	Iout = {+I1, +I2, +I3, +I4...}
	Qout = {+Q1, +Q2, +Q3, +Q4...}
fs/2	Iout = {+I1, -I2, +I3, -I4...}
	Qout = {+Q1, -Q2, +Q3, -Q4...}

**Table 7. Fs/2, Fs/4, and –Fs/4 Mixing Sequence (continued)**

MODE	MIXING SEQUENCE
fs/4	Iout = {+I1, -Q2, -I3, +Q4...}
	Qout = {+Q1, +I2, -Q3, -I4...}
-fs/4	Iout = {+I1, +Q2, -I3, -Q4...}
	Qout = {+Q1, -I2, -Q3, +I4...}

The fs/8 mixer can be enabled along with various combinations of fs/2, fs/4, and –fs/4 mixer. Since the fs/8 mixer uses the complex signal multiplier block with fixed fs/8 sine and cosine term, the output of the multiplier is:

$$I_{OUT}(t) = (I_{IN}(t)\cos(2\pi f_{NCO}t + \delta) - Q_{IN}(t)\sin(2\pi f_{NCO}t + \delta)) \times 2^{(mixer\_gain - 1)}$$

$$Q_{OUT}(t) = (I_{IN}(t)\sin(2\pi f_{NCO}t + \delta) + Q_{IN}(t)\cos(2\pi f_{NCO}t + \delta)) \times 2^{(mixer\_gain - 1)}$$

where  $f_{CMIX}$  is the fixed mixing frequency selected by *cmix(3:0)*. The mixing combinations are described in Table 8. The *mixer\_gain* option allows the output signals of the multiplier to reduce by half (6dB). See Mixer Gain section for details.

**Table 8. Coarse Mixer Combinations**

cmix(3:0)	Fs/8 MIXER cmix(3)	Fs/4 MIXER cmix(2)	Fs/2 MIXER cmix(1)	–Fs/4 MIXER cmix(0)	MIXING MODE
0000	Disabled	Disabled	Disabled	Disabled	No mixing
0001	Disabled	Disabled	Disabled	Enabled	–Fs/4
0010	Disabled	Disabled	Enabled	Disabled	Fs/2
0100	Disabled	Enabled	Disabled	Disabled	+Fs/4
1000	Enabled	Disabled	Disabled	Disabled	+Fs/8
1010	Enabled	Disabled	Enabled	Disabled	–3Fs/8
1100	Enabled	Enabled	Disabled	Disabled	+3Fs/8
1110	Enabled	Enabled	Enabled	Disabled	–Fs/8
All others	–	–	–	–	Not recommended

**7.3.7.3 Mixer Gain**

The maximum output amplitude out of the complex signal multiplier (i.e., FMIX mode or CMIX mode with fs/8 mixer enabled) occurs if  $I_{IN}(t)$  and  $Q_{IN}(t)$  are simultaneously full scale amplitude and the sine and cosine arguments are equal to  $2\pi \times f_{MIX}t + \delta (2N-1) \times \pi/4$ , where  $N = 1, 2, 3$ , etc....

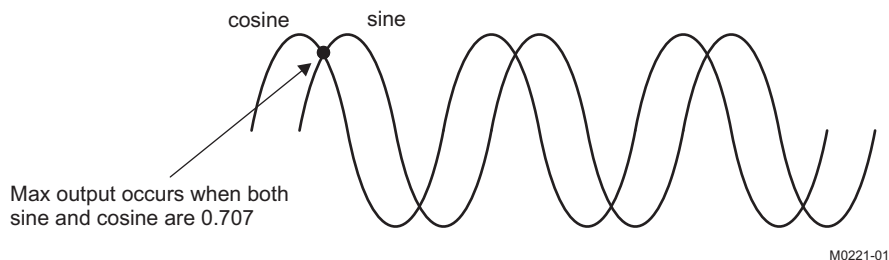

**Figure 72. Maximum Output of the Complex Signal Multiplier**

With *mixer\_gain* = 1 and both  $I_{IN}(t)$  and  $Q_{IN}(t)$  are simultaneously full scale amplitude, the maximum output possible out of the complex signal multiplier is  $0.707 + 0.707 = 1.414$  (or 3dB). This configuration can cause clipping of the signal and should therefore be used with caution.

With *mixer\_gain* = 0 in *config2*, the maximum output possible out of the complex signal multiplier is  $0.5 \times (0.707 + 0.707) = 0.707$  (or -3dB). This loss in signal power is in most cases undesirable, and it is recommended that the gain function of the QMC block be used to increase the signal by 3dB to compensate.

### 7.3.7.4 Real Channel Upconversion

The mixer in the DAC34H84 treats the A, B, C, and D inputs as complex input data and produces a complex output for most mixing frequencies. The real input data for each channel can be isolated only when the mixing frequency is set to normal mode or fs/2 mode. Refer to [Table 7](#) for details.

## 7.3.8 Quadrature Modulation Correction (QMC)

### 7.3.8.1 Gain and Phase Correction

The DAC3484 includes a Quadrature Modulator Correction (QMC) block. The QMC blocks provide a mean for changing the gain and phase of the complex signals to compensate for any I and Q imbalances present in an analog quadrature modulator. The block diagram for the QMC block is shown in [Figure 73](#). The QMC block contains 3 programmable parameters.

Register *qmc\_gainA/B(10:0)* and *qmc\_gainC/D(10:0)* controls the I and Q path gains and is an 11-bit unsigned value with a range of 0 to 1.9990 and the default gain is 1.0000. The implied decimal point for the multiplication is between bit 9 and bit 10.

Register *qmc\_phaseAB/CD(11:0)* control the phase imbalance between I and Q and is a 12-bit values with a range of  $-0.5$  to approximately 0.49975. The QMC phase term is not a direct phase rotation but a constant that is multiplied by each "Q" sample then summed into the "I" sample path. This is an approximation of a true phase rotation in order to keep the implementation simple. The corresponding phase rotation corresponds to approximately  $+26.5$  to  $-26.5$  degrees in 4096 steps.

LO feed-through can be minimized by adjusting the DAC offset feature described below.

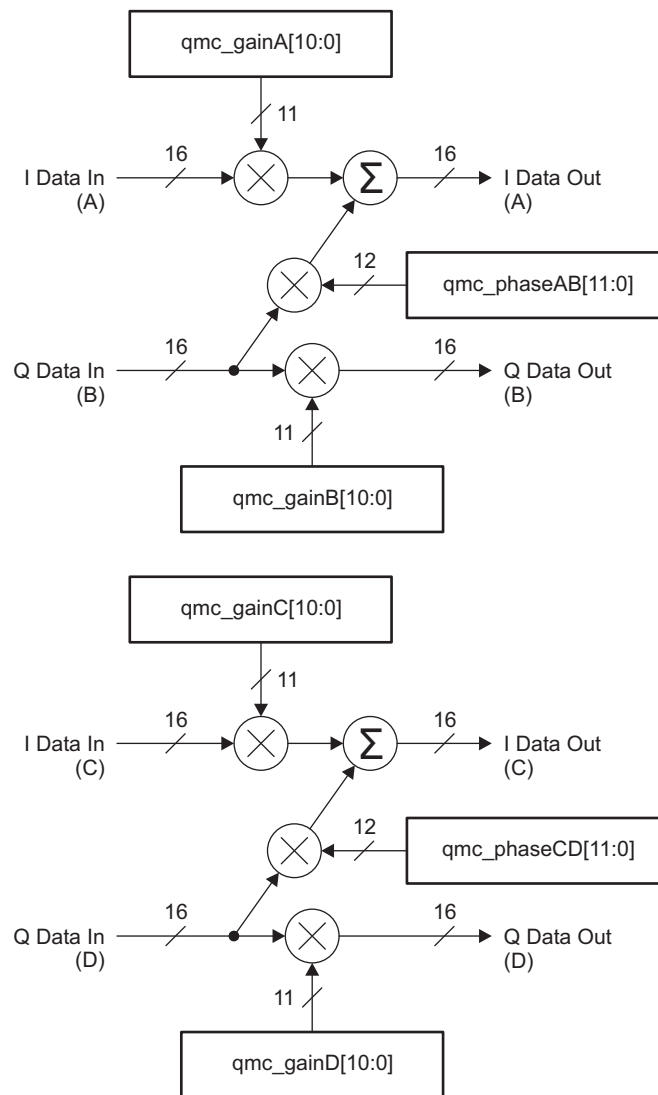

B0164-03

**Figure 73. QMC Block Diagram**

### 7.3.8.2 Offset Correction

Registers *qmc\_offsetA(12:0)*, *qmc\_offsetB(12:0)*, *qmc\_offsetC(12:0)* and *qmc\_offsetD(12:0)* can be used to independently adjust the DC offsets of each channel. The offset values are represented in 2s-complement format with a range from -4096 to 4095.

The offset value adds a digital offset to the digital data before digital-to-analog conversion. Since the offset is added directly to the data it may be necessary to back off the signal to prevent saturation. Both data and offset values are LSB aligned.

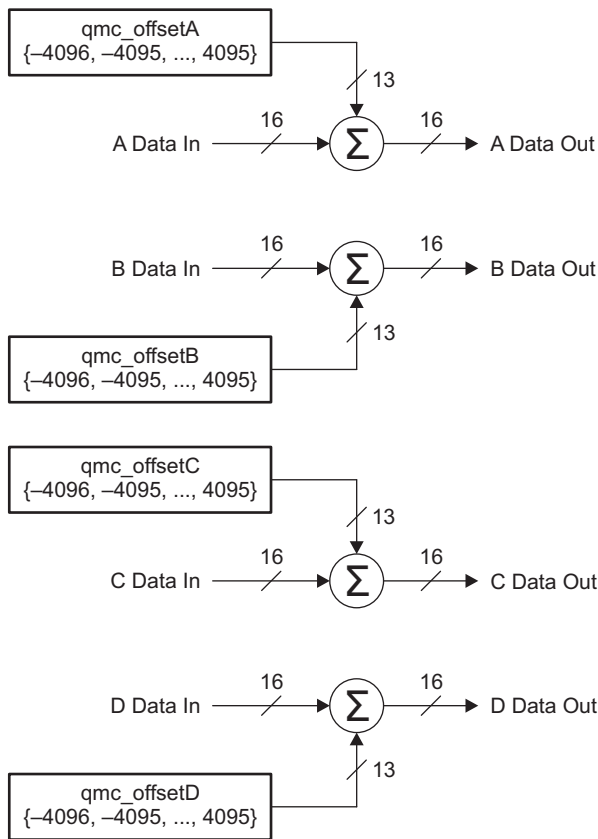

B0165-03

Figure 74. Digital Offset Block Diagram

### 7.3.8.3 Group Delay Correction

A complex transmitter system typically is consisted of DACs, reconstruction filter network, and I/Q modulator. Besides the gain and phase mismatch contribution, there could also be timing mismatch contribution from each components. For instance, the timing mismatch could come from the PCB trace length variation between the I and Q channels and the group delay variation from the reconstruction filter.

This timing mismatch in the complex transmitter system creates phase mismatch that varies linearly with respect to frequency. To compensate for the I/Q imbalances due to this mismatch, the DAC3484 has group delay correction block for each DAC channel. Each DAC channel can adjust its delay through *grp\_delayA(7:0)*, *grp\_delayB(7:0)*, *grp\_delayC(7:0)*, and *grp\_delayD(7:0)* in register *config46* and *config47*. The group delay correction, along with gain/phase correction, can be useful for correcting imbalances in wide-band transmitter system. The maximum delay ranges from 30 ps to 100 ps and is dependent on DAC sample clock. Contact TI for specific application information.

### 7.3.9 Temperature Sensor

The DAC3484 incorporates a temperature sensor block which monitors the temperature by measuring the voltage across 2 transistors. The voltage is converted to an 8-bit digital word using a successive-approximation (SAR) analog to digital conversion process. The result is scaled, limited and formatted as a twos complement value representing the temperature in degrees Celsius.

The sampling is controlled by the serial interface signals SDENB and SCLK. If the temperature sensor is enabled (*tsense\_sleep* = 0b in register *config26*) a conversion takes place each time the serial port is written or read. The data is only read and sent out by the digital block when the temperature sensor is read in *tempdata(7:0)* in *config6*. The conversion uses the first eight clocks of the serial clock as the capture and conversion clock, the data is valid on the falling eighth SCLK. The data is then clocked out of the chip on the rising edge of the ninth SCLK. No other clocks to the chip are necessary for the temperature sensor operation. As a result the temperature sensor is enabled even when the device is in sleep mode.

In order for the process described above to operate properly, the serial port read from *config6* must be done with an SCLK period of at least 1  $\mu$ s. If this is not satisfied the temperature sensor accuracy is greatly reduced.

### 7.3.10 Data Pattern Checker

The DAC3484 incorporates a simple pattern checker test in order to determine errors in the data interface. The main cause of failures is setup/hold timing issues. The test mode is enabled by asserting *iotest\_ena* in register *config1*. In test mode the analog outputs are deactivated regardless of the state of TXENABLE or *sif\_textnable* in register *config3*.

The data pattern key used for the test is 8 words long and is specified by the contents of *iotest\_pattern[0:7]* in registers *config37* through *config44*. The data pattern key can be modified by changing the contents of these registers.

The first word in the test frame is determined by a rising edge transition in FRAME or SYNC, depending on the *syncsel\_fifo(4:0)* setting in *config32*. At this transition, the *pattern0* word should be input to the data pins. Patterns 1 through 7 should follow sequentially on each edge of DATACLK (rising and falling). The sequence should be repeated until the pattern checker test is disabled by setting *iotest\_ena* back to 0b. It is not necessary to have a rising FRAME or SYNC edge aligned with every *pattern0* word, just the first one to mark the beginning of the series.

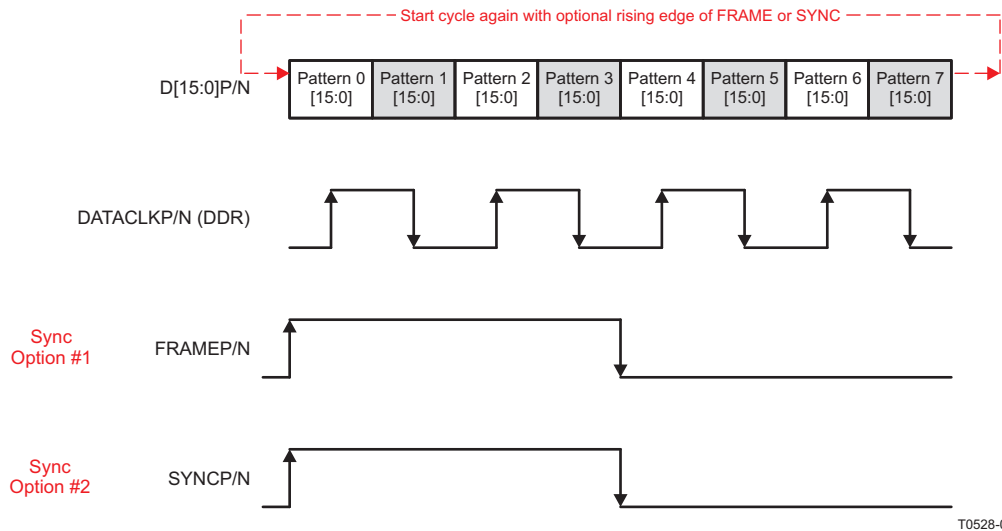

Figure 75. IO Pattern Checker Data Transmission Format

The test mode determines if the 16-bit LVDS data D[15:0]P/N of all the patterns were received correctly by comparing the received data against the data pattern key. If any of the 16-bit data D[15:0]P/N were received incorrectly, the corresponding bits in *iotest\_results(15:0)* in register *config4* will be set to 1b to indicate bit error location. Furthermore, the error condition will trigger the *alarm\_from\_iotest* bit in register *config5* to indicate a general error in the data interface. When data pattern checker mode is enabled, this alarm in register *config5*, bit 7 is the only valid alarm. Other alarms in register *config5* are not valid and can be disregarded.

For instance, *pattern0* is programmed to the default of 0x7A7A. If the received Pattern 0 is 0x7A7B, then bit 0 in *iotest\_results(15:0)* will be set to 1b to indicate an error in bit 0 location. The *alarm\_from\_iotest* will also be set to 1b to report the data transfer error. The user can then narrow down the error from the bit location information and implement the fix accordingly.

The alarms can be cleared by writing 0x0000 to *iotest\_results(15:0)* and 0b to *alarm\_from\_iotest* through the serial interface. The serial interface will read back 0s if there are no errors or if the errors are cleared. The corresponding alarm bit will remain a 1b if the errors remain.

It is recommended to enable the pattern checker and then run the pattern sequence for 100 or more complete cycles before clearing the *iotest\_results(15:0)* and *alarm\_from\_iotest*. This will eliminate the possibility of false alarms generated during the setup sequence.

Based on the pattern test result, the user can adjust the data source output timing, PCB traces delay, or DAC3484 CONFIG36 LVDS Programmable delay to help optimize the setup and hold time of the transmitter system.

**DAC3484**

SLAS749E –MARCH 2011–REVISED NOVEMBER 2015

www.ti.com

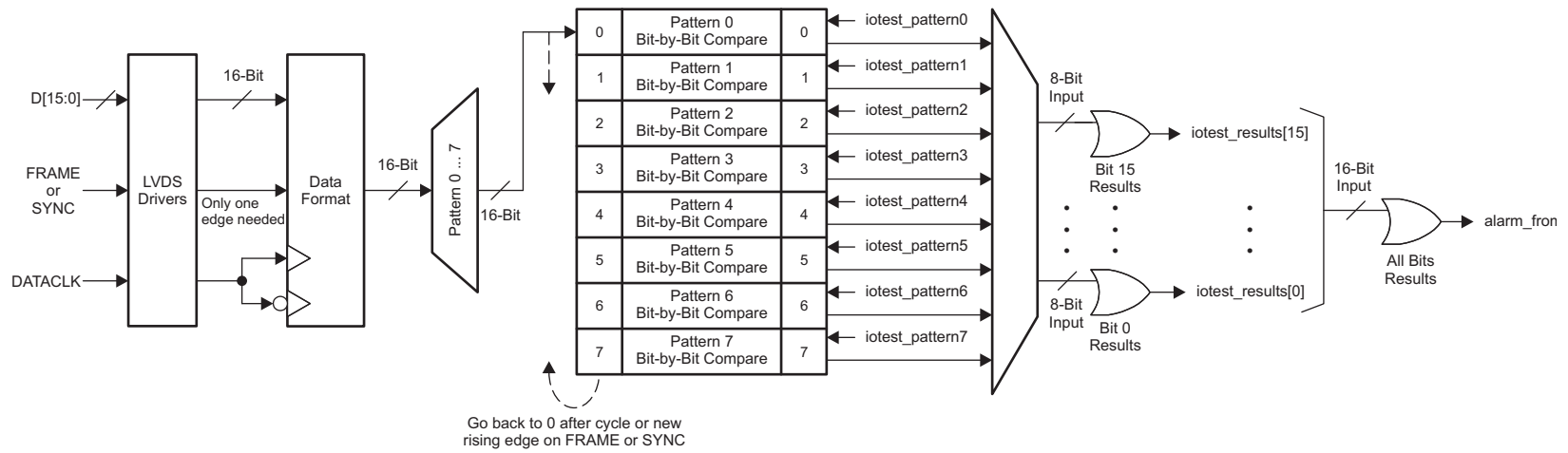

**Figure 76. DAC3484 Pattern Check Block Diagram**

### 7.3.11 Parity Check Test

The DAC3484 has a parity check test that enables continuous validity monitoring of the data received by the DAC. Parity check testing in combination with the data pattern checker offer an excellent solution for detecting board assembly issues due to missing pad connections.

For the parity check test, an extra parity bit is added to the data bits to ensure that the total number of set bits (bits with value 1) is even or odd. This simple scheme is used to detect single or any other odd number of data transfer errors. Parity testing is implemented in the DAC3484 in two ways: word-by-word parity and block parity.

#### 7.3.11.1 Word-by-Word Parity

Word-by-word parity is the easiest mode to implement. In this mode the additional parity bit is sourced to the parity input (PARITYP/N) for each data word transfer into the D[15:0]P/N inputs. This mode is enabled by setting the *word\_parity\_ena* bit. The input parity value is defined to be the total number of logic 1s on the 17-bit data bus, the D[15:0]P/N inputs and the PARITYP/N input. This value, the total number of logic 1s, must match the parity test selected in the *oddeven\_parity* bit in register *config1*.

For example, if the *oddeven\_parity* bit is set to 1b for odd parity, then the number of 1s on the 17-bit data bus should be odd. The DAC will check the data transfer through the parity input. If the data received has odd number of 1s, then the parity is correct. If the data received has even number of 1s, then the parity is incorrect. The corresponding alarm for parity error will be set accordingly.

Figure 77 shows the simple XOR structure used to check word parity. Parity is tested independently for data captured on both rising and falling edges of DATACLK (*alarm\_rparity* and *alarm\_fparity*, respectively). Testing on both edges helps in determining a possible setup/hold issue. Both alarms are captured individually in register *config5*.

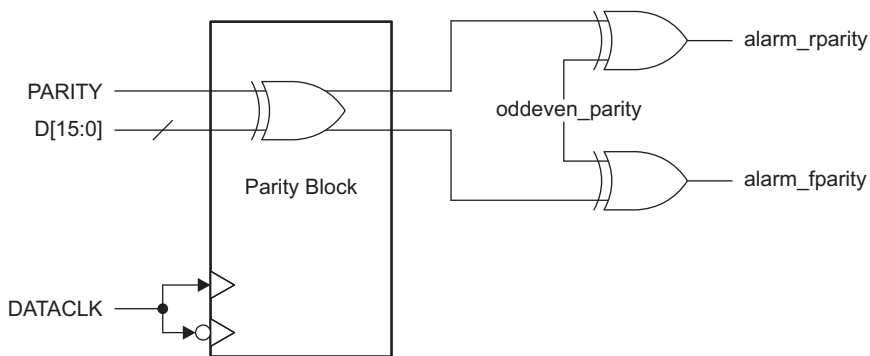

B0458-01

Figure 77. DAC3484 Word-by-Word Parity Check

#### 7.3.11.2 Block Parity

The block parity method uses the FRAME signal to determine the boundaries of the data block to compute parity. This mode is enabled by setting the *frame\_parity\_ena* bit in register *config1*.

A low-to-high transition of FRAME captured with the DATACLK rising edge determines the end point of the parity block and the beginning of the next one. In this method the parity bit of the completed block corresponds to the FRAME value captured on the DATACLK falling edge right after the STOP/START point.

The input parity value is defined to be the total number of logic 1s in the data block. A logic HIGH captured on the falling edge of DATACLK indicates odd parity or odd number of logic 1s, while a logic LOW indicates even parity or even number of logic 1s. If the expected parity does not match the number of logic 1s in the received data, then *alarm\_frame\_parity* in register *config5* will be set to 1b. The main advantage of the block parity mode is that there is no need for an additional parity LVDS input.

Since the FRAME signal is used for parity testing in addition to FIFO syncing and frame boundary assignment it is mandatory to take some extra steps to avoid device malfunction. If FRAME is used to reset the FIFO pointers continuously, the block size must be a multiple of 8 samples (each sample corresponding to 16-bits A, B, C and D data). In addition since FRAME is used to establish the frame boundary, the parity block must be aligned with the data frame boundaries.

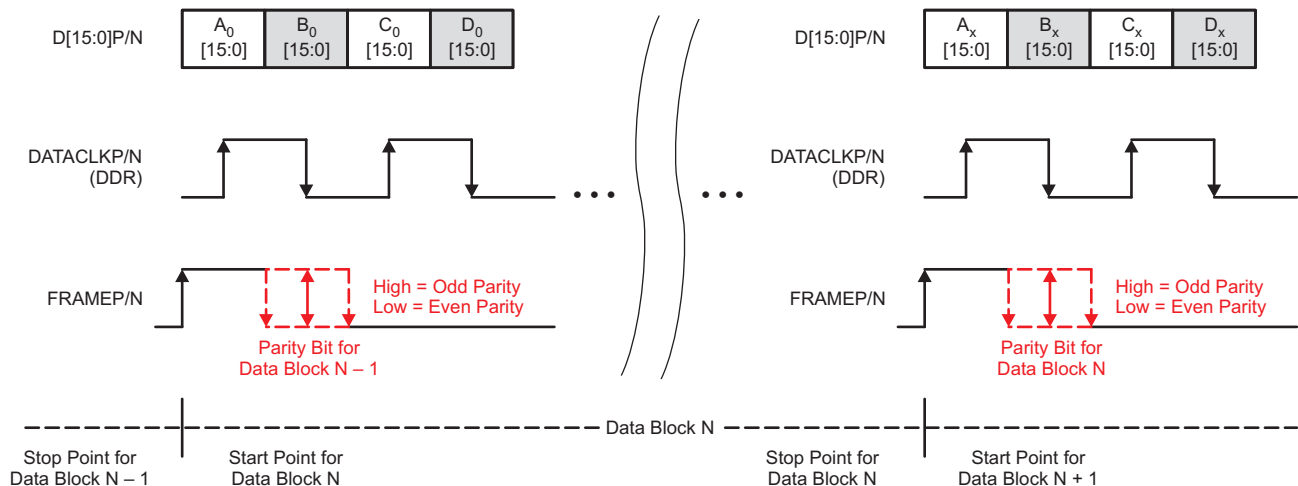

T0527-02

Notes: Rising edge of FRAMEP/N indicates the beginning of data block.

Parity bit for the current data block is latched on falling edge of DATACLK after the start point for next data block.

**Figure 78. DAC3484 Block Parity Check (Example shown with Word Wide Mode)**

### 7.3.12 DAC3484 Alarm Monitoring

The DAC3484 includes a flexible set of alarm monitoring that can be used to alert of a possible malfunction scenario. All the alarm events can be accessed either through the *config5* register or through the ALARM pin. Once an alarm is set, the corresponding alarm bit in register *config5* must be reset through the serial interface to allow further testing. The set of alarms includes the following conditions:

#### Zero check alarm

- *Alarm\_from\_zerock*. Occurs when the FIFO write pointer has an all zeros pattern. Since the write pointer is a shift register, all zeros will cause the input pointer to be stuck until the next sync event. When this happens a sync to the FIFO block is required.

#### FIFO alarms

- *alarm\_from\_fifo*. Occurs when there is a collision in the FIFO pointers or a collision event is close.
  - *alarm\_fifo\_2away*. Pointers are within two addresses of each other.
  - *alarm\_fifo\_1away*. Pointers are within one address of each other.
  - *alarm\_fifo\_collision*. Pointers are equal to each other.

#### Clock alarms

- *clock\_gone*. Occurs when either the DACCLK or DATALOCK have been stopped.
  - *alarm\_dacclk\_gone*. Occurs when the DACCLK has been stopped.
  - *alarm\_dataclk\_gone*. Occurs when the DATACLK has been stopped.

#### Pattern checker alarm

- *alarm\_from\_iotest*. Occurs when the input data pattern does not match the pattern key.

#### PLL alarm

- *alarm\_from\_pll*. Occurs when the PLL is out of lock.

#### Parity alarms

- *alarm\_rparity*. Occurs when there is a parity error in the data captured by the rising edge of DATACLKP/N. The PARITYP/N input is the parity bit (word-by-word parity test).
- *alarm\_fparity*. Occurs when there is a parity error in the data captured by the falling edge of DATACLKP/N. The PARITYP/N input is the parity bit (word-by-word parity test).
- *alarm\_frame\_parity\_err*. Occurs when there is a frame parity error when using the FRAME as the parity bit (block parity test).

To prevent unexpected DAC outputs from propagating into the transmit channel chain, the clock and alarm\_fifo\_collision alarms can be set in *config2* to shut-off the DAC output automatically regardless of the state of TXENABLE or *sif\_txenable*.

Alarm monitoring is implemented as follows:

- Power up the device using the recommended power-up sequence.
- Clear all the alarms in *config5* by setting them to 0.
- Unmask those alarms that will generate a hardware interrupt through the ALARM pin in *config7*.
- Enable automatic DAC shut-off in register *config2* if required.
- In the case of an alarm event, the ALARM pin will trigger. If automatic DAC shut-off has been enabled the DAC outputs will be disabled.
- Read registers *config5* to determine which alarm triggered the ALARM pin.
- Correct the error condition and re-synchronize the FIFO.
- Clear the alarms in *config5*.
- Re-read *config5* to ensure the alarm event has been corrected.
- Keep clearing and reading *config5* until no error is reported.

For details of alarm monitoring function and behavior, refer to [SLAA585](#).

### 7.3.13 LVPECL Inputs

Figure 79 shows an equivalent circuit for the DAC input clock (DACCLKP/N) and the output strobe clock (OSTRP/N).

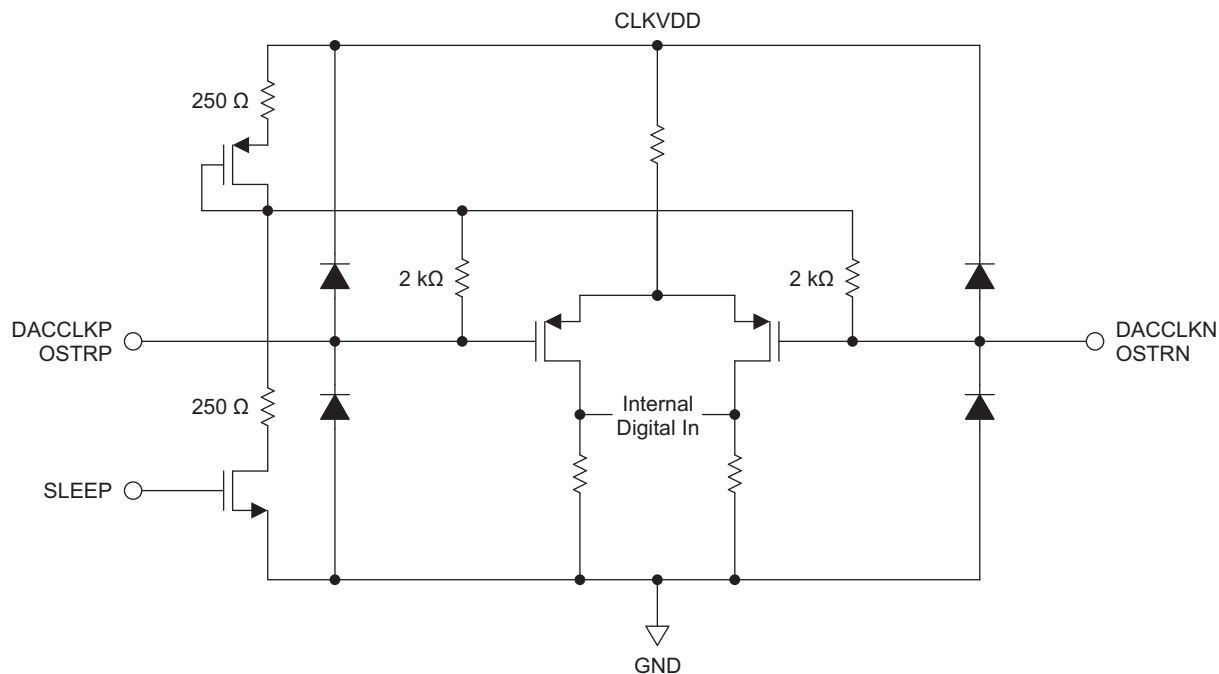

S0515-01

NOTE: Input common mode level is internally biased

**Figure 79. DACCLKP/N and OSTRP/N Equivalent Input Circuit**

Figure 80 shows the preferred configuration for driving the CLKIN/CLKINC input clock with a differential ECL/PECL source.

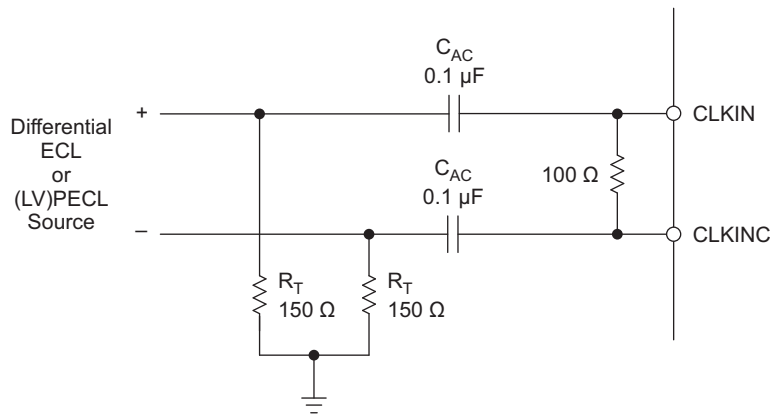

S0029-02

NOTE: Actual  $R_T$  value depends on differential clock driver output termination recommendation. It is driver type dependent.

**Figure 80. Preferred Clock Input Configuration with a Differential ECL/PECL Clock Source**

### 7.3.14 LVDS Inputs

The D[15:0]P/N, DATACLKP/N, SYNCP/N, PARITYP/N, and FRAMEP/N LVDS pairs have the input configuration shown in Figure 81. Figure 82 shows the typical input levels and common-mode voltage used to drive these inputs.

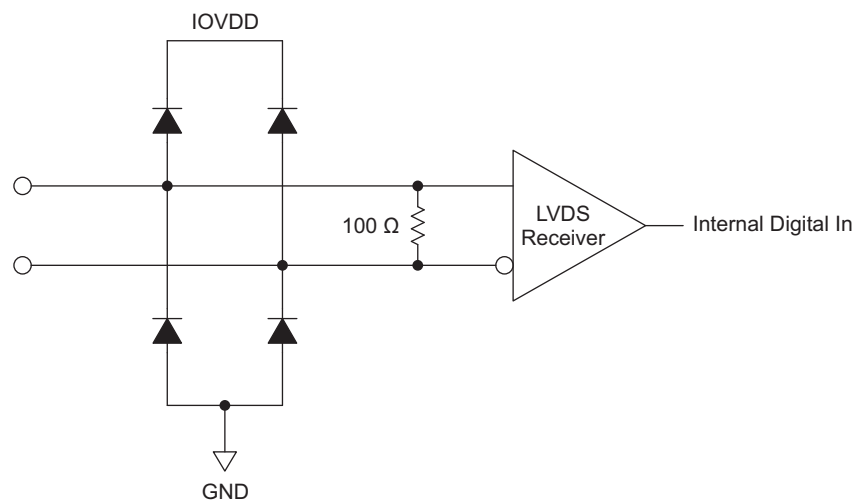

S0516-01

**Figure 81. D[15:0]P/N, DATACLKP/N, FRAMEP/N, SYNCP/N and PARITYP/N LVDS Input Configuration**

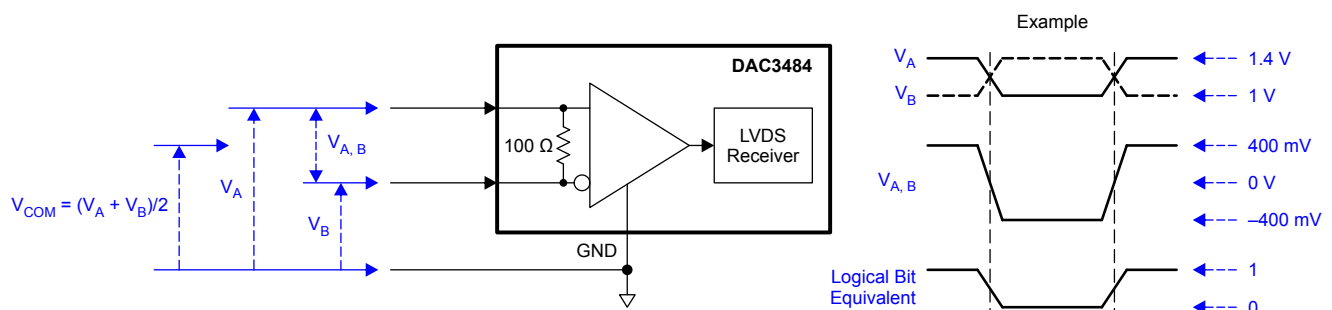

B0459-03

**Figure 82. LVDS Data Input Levels**

**Table 9. Example LVDS Data Input Levels**

APPLIED VOLTAGES		RESULTING DIFFERENTIAL VOLTAGE	RESULTING COMMON-MODE VOLTAGE	LOGICAL BIT BINARY EQUIVALENT
V <sub>A</sub>	V <sub>B</sub>	V <sub>A,B</sub>	V <sub>COM</sub>	
1.4 V	1.0 V	400 mV	1.2 V	1
1.0 V	1.4 V	-400 mV		0
1.2 V	0.8 V	400 mV	1.0 V	1
0.8 V	1.2 V	-400 mV		0

**7.3.15 Unused LVDS Port Termination**

Depending on the DAC3484 functionality required, additional unused LVDS ports such as FRAMEP/N, SYNC/N, or PARITYP/N can be left unconnected (floating) or connected to a nominal, differential LVDS active HIGH or active LOW voltage. The usage of these ports depends mainly on the FIFO synchronization settings and parity checking settings. The unused FRAMEP/N, SYNC/N, or PARITYP/N ports can be connected in parallel with the unused LVDS data port with adjustments to the R<sub>SET</sub> resistor value.

The following example allows the termination of the unused LVDS ports to a known logic HIGH value. As shown in Figure 83, The design involves the connection to the DIGVDD rail and one R<sub>SET</sub> resistor to bias the positive terminals of unused LVDS ports to be 1.2 V and negative terminals of unused LVDS ports to 1.0 V. The design keeps the minimum common mode input voltage of the LVDS input to be above 1.0 V, and keeps the differential LVDS voltage to be 200 mV. Since the design expects the differential voltage on the unused ports to be static, the differential LVDS voltage can be as low as 100 mV to maintain a logic HIGH. Refer to Electrical Characteristic – Digital Specifications Table for detail of LVDS Input requirements.

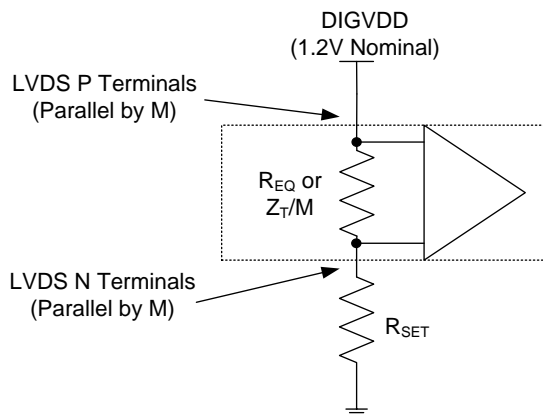

- M Unused LVDS Ports Connected in Parallel.
- Keep Positive Terminals at 1.2V.
- Keep Static Differential Voltages above 100mV.

**Figure 83. Unused LVDS Ports Connected to Static Logic High Differential Voltage**

1. Connect the positive terminals of unused LVDS ports in parallel to DIGVDD supply at 1.2 V nominal. For instance, connect SYNC and PARITY positive pins together to DIGVDD.
2. Connect the negative terminals of unused LVDS ports in parallel to a R<sub>SET</sub> resistor to ground.
3. The R<sub>EQ</sub> value is the equivalent, parallel resistance of the on-chip termination for all the unused LVDS ports. With the SYNC and PARITY ports unused, the R<sub>EQ</sub> is two parallel Z<sub>T</sub>. Worst case Z<sub>T</sub> value of 135 Ω is used in the design to account for the lowest possible current I<sub>EQ</sub> and the worst case common mode on the negative LVDS terminals. Another analysis will be performed with Z<sub>T</sub> value of 85 Ω for worst case differential LVDS voltages.
4. With Ohm’s Law, the following equation describes the relationship between R<sub>SET</sub> and R<sub>EQ</sub>.

$$\frac{R_{SET}}{R_{SET} + R_{EQ}} = \frac{1.0}{1.2}$$

$$R_{SET} = 4.988R_{EQ} \quad (2)$$

- With  $R_{EQ}$  of two parallel,  $135 \Omega$   $Z_T$  (or  $67.5 \Omega$  equivalent),  $R_{SET}$  is  $332 \Omega$  with standard 1% resistor value.  $I_{EQ}$  is approximately 3 mA. The expected voltage at negative terminals of LVDS ports is approximately 1.0 V. The differential LVDS voltage is 200 mV.
- With same  $R_{SET}$  of  $332 \Omega$ , if the  $R_{EQ}$  has dropped to two parallel,  $85 \Omega$   $Z_T$  (or  $42.5 \Omega$  equivalent),  $I_{EQ}$  is approximately 3.2 mA. The expected voltage at negative terminals of LVDS port is approximately 1.06 V. The differential LVDS voltage is 136 mV. As long as the static LVDS differential voltage is above 100 mV, the LVDS port will register a logic HIGH value for the data.

### 7.3.16 CMOS Digital Inputs

Figure 84 shows a schematic of the equivalent CMOS digital inputs of the DAC3484. SDIO, SCLK, SLEEP and TXENABLE have pull-down resistors while SDENB and RESETB have pull-up resistors internal to the DAC3484. See the specification table for logic thresholds. The pull-up and pull-down circuitry is approximately equivalent to  $100k\Omega$ .

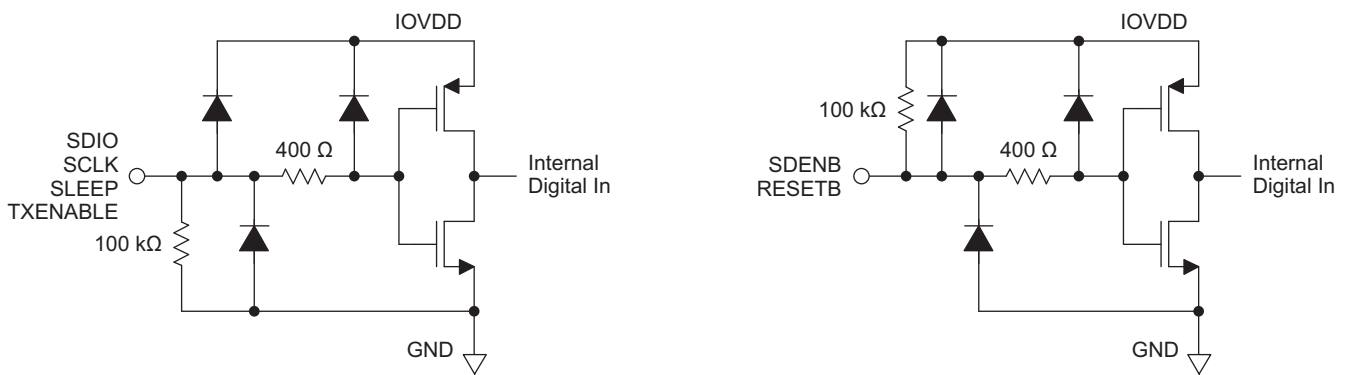

S0027-03

**Figure 84. CMOS Digital Equivalent Input**

### 7.3.17 Reference Operation

The DAC3484 uses a bandgap reference and control amplifier for biasing the full-scale output current. The full-scale output current is set by applying an external resistor  $R_{BIAS}$  to pin BIASJ. The bias current  $I_{BIAS}$  through resistor  $R_{BIAS}$  is defined by the on-chip bandgap reference voltage and control amplifier. The default full-scale output current equals 64 times this bias current and can thus be expressed as:

$$IOUT_{FS} = 64 \times I_{BIAS} = 64 \times (V_{EXTIO} / R_{BIAS}) / 2$$

The DAC3484 has a 4-bit coarse gain control *coarse\_dac(3:0)* in the *config3* register. Using gain control, the  $IOUT_{FS}$  can be expressed as:

$$IOUT_{FS} = (coarse\_dac + 1)/16 \times I_{BIAS} \times 64 = (coarse\_dac + 1)/16 \times (V_{EXTIO} / R_{BIAS}) / 2 \times 64$$

where  $V_{EXTIO}$  is the voltage at terminal EXTIO. The bandgap reference voltage delivers an accurate voltage of 1.2 V. This reference is active when *extref\_ena* = 0b in *config27*. An external decoupling capacitor  $C_{EXT}$  of  $0.1 \mu F$  should be connected externally to terminal EXTIO for compensation. The bandgap reference can additionally be used for external reference operation. In that case, an external buffer with high impedance input should be applied in order to limit the bandgap load current to a maximum of 100 nA. The internal reference can be disabled and overridden by an external reference by setting the *extref\_ena* control bit. Capacitor  $C_{EXT}$  may hence be omitted. Terminal EXTIO thus serves as either input or output node.

The full-scale output current can be adjusted from 30 mA down to 10 mA by varying resistor  $R_{BIAS}$  or changing the externally applied reference voltage.

**NOTE**

With internal reference, the minimum  $R_{bias}$  resistor value is 1.28 k $\Omega$ . Resistor value below 1.28 k $\Omega$  is not recommended since it will program the full-scale current to go above 30mA and potentially damages the device.

**7.3.18 DAC Transfer Function**

The CMOS DACs consist of a segmented array of PMOS current sources, capable of sourcing a full-scale output current up to 30 mA. Differential current switches direct the current to either one of the complementary output nodes IOU<sub>TP</sub> or IOU<sub>TN</sub>. Complementary output currents enable differential operation, thus canceling out common mode noise sources (digital feed-through, on-chip and PCB noise), dc offsets, even order distortion components, and increasing signal output power by a factor of two.

The full-scale output current is set using external resistor  $R_{BIAS}$  in combination with an on-chip bandgap voltage reference source (+1.2 V) and control amplifier. Current  $I_{BIAS}$  through resistor  $R_{BIAS}$  is mirrored internally to provide a maximum full-scale output current equal to 64 times  $I_{BIAS}$ .

The relation between IOU<sub>TP</sub> and IOU<sub>TN</sub> can be expressed as:

$$IOUT_{FS} = IOUTP + IOUTN$$

We will denote current flowing into a node as – current and current flowing out of a node as + current. Since the output stage is a current source the current flows from the IOU<sub>TP</sub> and IOU<sub>TN</sub> pins. The output current flow in each pin driving a resistive load can be expressed as:

$$IOUTP = IOUT_{FS} \times CODE / 65536$$

$$IOUTN = IOUT_{FS} \times (65535 - CODE) / 65536$$

where CODE is the decimal representation of the DAC data input word

For the case where IOU<sub>TP</sub> and IOU<sub>TN</sub> drive resistor loads  $R_L$  directly, this translates into single ended voltages at IOU<sub>TP</sub> and IOU<sub>TN</sub>:

$$VOUTP = IOUT1 \times R_L$$

$$VOUTN = IOUT2 \times R_L$$

Assuming that the data is full scale (65535 in offset binary notation) and the  $R_L$  is 25  $\Omega$ , the differential voltage between pins IOU<sub>TP</sub> and IOU<sub>TN</sub> can be expressed as:

$$VOUTP = 20mA \times 25 \Omega = 0.5 V$$

$$VOUTN = 0mA \times 25 \Omega = 0 V$$

$$VDIFF = VOUTP - VOUTN = 0.5V$$

Note that care should be taken not to exceed the compliance voltages at node IOU<sub>TP</sub> and IOU<sub>TN</sub>, which would lead to increased signal distortion.

**7.3.19 Analog Current Outputs**

The DAC3484 can be easily configured to drive a doubly terminated 50- $\Omega$  cable using a properly selected RF transformer. [Figure 85](#) and [Figure 86](#) show the 50- $\Omega$  doubly terminated transformer configuration with 1:1 and 4:1 impedance ratio, respectively. Note that the center tap of the primary input of the transformer has to be grounded to enable a DC current flow. Applying a 20-mA full-scale output current would lead to a 0.5 V<sub>pp</sub> for a 1:1 transformer and a 1 V<sub>pp</sub> output for a 4:1 transformer. The low dc-impedance between IOU<sub>TP</sub> or IOU<sub>TN</sub> and the transformer center tap sets the center of the ac-signal to GND, so the 1 V<sub>pp</sub> output for the 4:1 transformer results in an output between –0.5 V and 0.5 V.

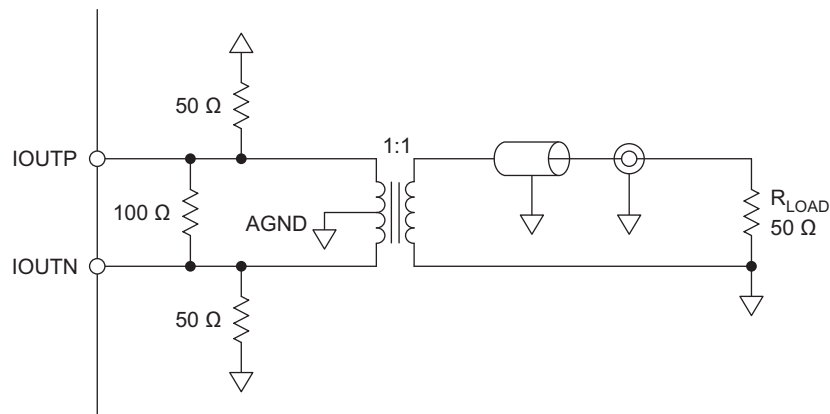

S0517-01

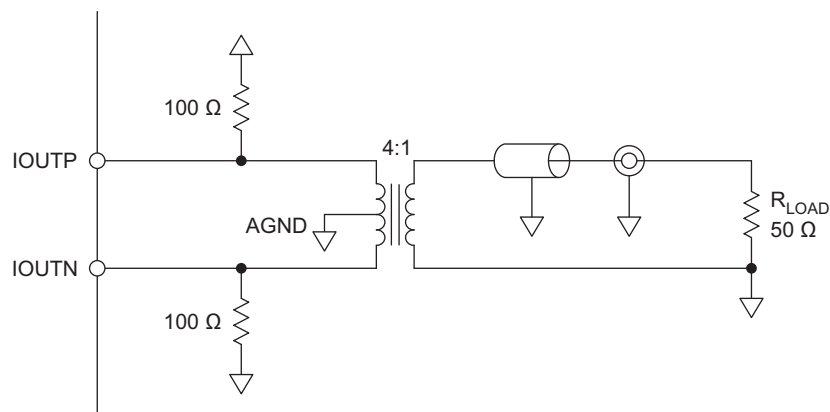
**Figure 85. Driving a Doubly terminated 50-Ω Cable Using a 1:1 Impedance Ratio Transformer**

S0518-01

**Figure 86. Driving a Doubly Terminated 50-Ω Cable Using a 4:1 Impedance Ratio Transformer**

## 7.4 Device Functional Modes

### 7.4.1 Multi-Device Synchronization

In various applications, such as multi antenna systems where the various transmit channels information is correlated, it is required that multiple DAC devices are completely synchronized such that their outputs are phase aligned. The DAC3484 architecture supports this mode of operation.

#### 7.4.1.1 Multi-Device Synchronization: PLL Bypassed with Dual Sync Sources Mode

For single or multi-device synchronization it is important that delay differences in the data are absorbed by the device so that latency through the device remains the same. Furthermore, to guarantee that the outputs from each DAC are phase aligned it is necessary that data is read from the FIFO of each device simultaneously. In the DAC3484 this is accomplished by operating the multiple devices in Dual Sync Sources mode. In this mode the additional OSTR signal is required by each DAC3484 to be synchronized.

Data into the device is input as LVDS signals from one or multiple baseband ASICs or FPGAs. Data into the multiple DAC devices can experience different delays due to variations in the digital source output paths or board level wiring. These different delays can be effectively absorbed by the DAC3484 FIFO so that all outputs are phase aligned correctly.

Device Functional Modes (continued)

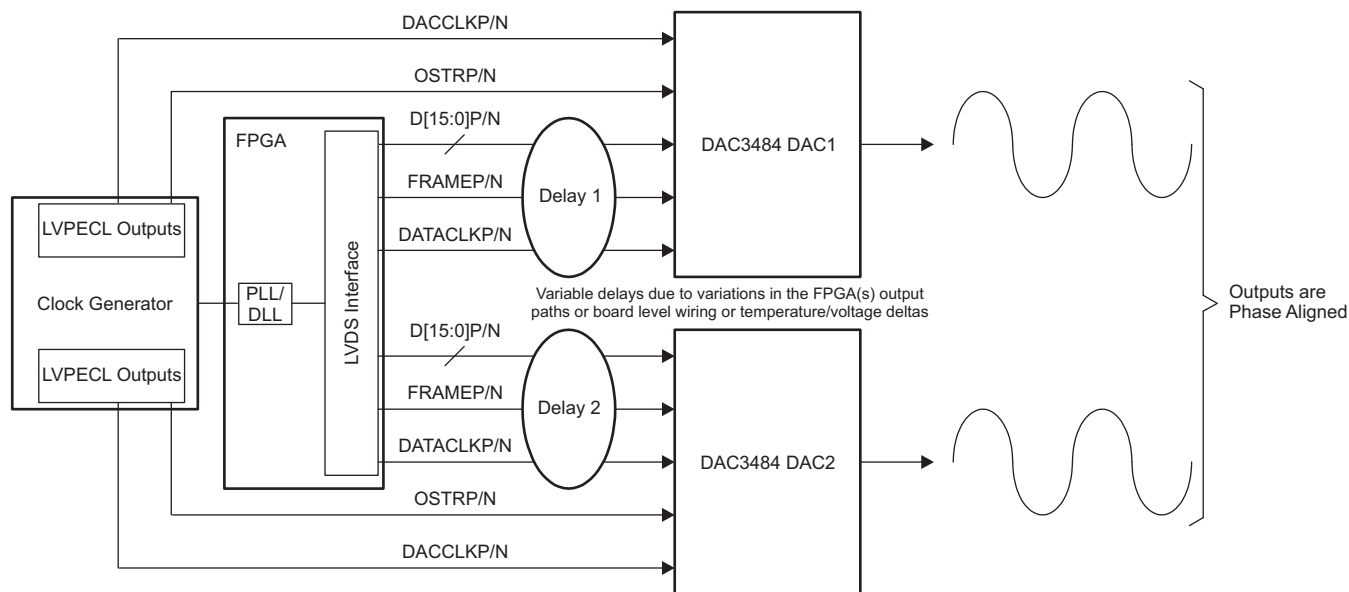

B0454-03

Figure 87. SynchronizationSystem in Dual Sync Sources Mode with PLL Bypassed

For correct operation both OSTR and DACCLK must be generated from the same clock domain. The OSTR signal is sampled by DACCLK and must satisfy the timing requirements in the specifications table. If the clock generator does not have the ability to delay the DACCLK to meet the OSTR timing requirement, the polarity of the DACCLK outputs can be swapped with respect to the OSTR ones to create 180 degree phase delay of the DACCLK. This may help establish proper setup and hold time requirement of the OSTR signal.

Careful board layout planning must be done to ensure that the DACCLK and OSTR signals are distributed from device to device with the lowest skew possible as this will affect the synchronization process. In order to minimize the skew across devices it is recommended to use the same clock distribution device to provide the DACCLK and OSTR signals to all the DAC devices in the system.

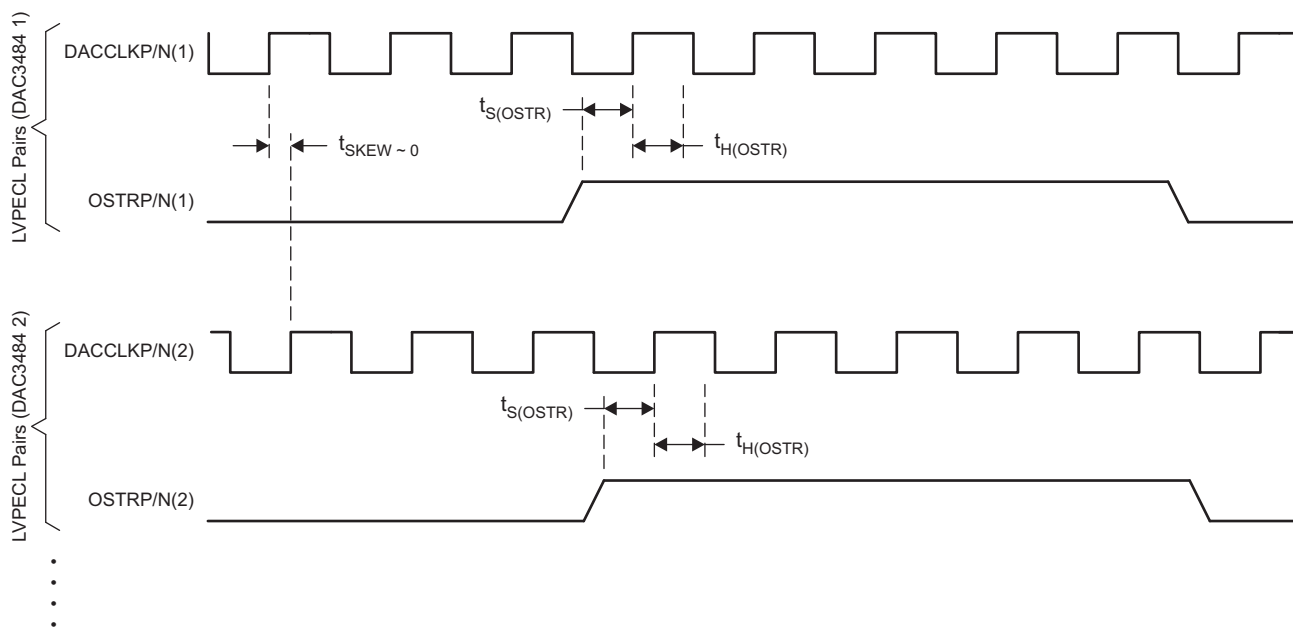
**Device Functional Modes (continued)**

T0526-03

**Figure 88. Timing Diagram for LVPECL Synchronization Signals**

The following steps are required to ensure the devices are fully synchronized. The procedure assumes all the DAC3484 devices have a DACCLK and OSTR signal and must be carried out on each device.

1. Start-up the device as described in the power-up sequence. Set the DAC3484 in Dual Sync Sources mode and select OSTR as the clock divider sync source (*clkdiv\_sync\_sel* in register *config32*).
2. Sync the clock divider and FIFO pointers.
3. Verify there are no FIFO alarms either through register *config5* or through the ALARM pin.
4. Disable clock divider sync by setting *clkdiv\_sync\_ena* to 0b in register *config0*.

After these steps all the DAC3484 outputs will be synchronized.

**7.4.1.2 Multi-Device Synchronization: PLL Enabled with Dual Sync Sources Mode**

The DAC3484 allows exact phase alignment between multiple devices even when operating with the internal PLL clock multiplier. In PLL clock mode, the PLL generates the DAC clock and an internal OSTR signal from the reference clock applied to the DACCLK inputs so there is no need to supply an additional LVPECL OSTR signal.

For this method to operate properly the SYNC signal should be set to reset the PLL N dividers to a known state by setting *pll\_ndivsync\_ena* in register *config24* to 1b. The SYNC signal resets the PLL N dividers with a rising edge, and the timing relationship  $t_{s(\text{SYNC\_PLL})}$  and  $t_{h(\text{SYNC\_PLL})}$  are relative to the reference clock presented on the DACCLK pin.

Both SYNC and DACCLK can be set as low frequency signals to greatly simplifying trace routing (SYNC can be just a pulse as a single rising edge is required, if using a periodic signal it is recommended to clear the *pll\_ndivsync\_ena* bit after resetting the PLL dividers). Besides the  $t_{s(\text{SYNC\_PLL})}$  and  $t_{h(\text{SYNC\_PLL})}$  requirement between SYNC and DACCLK, there is no additional required timing relationship between the SYNC and FRAME signals or between DACCLK and DATACLK. The only restriction as in the PLL disabled case is that the DACCLK and SYNC signals are distributed from device to device with the lowest skew possible.

Device Functional Modes (continued)

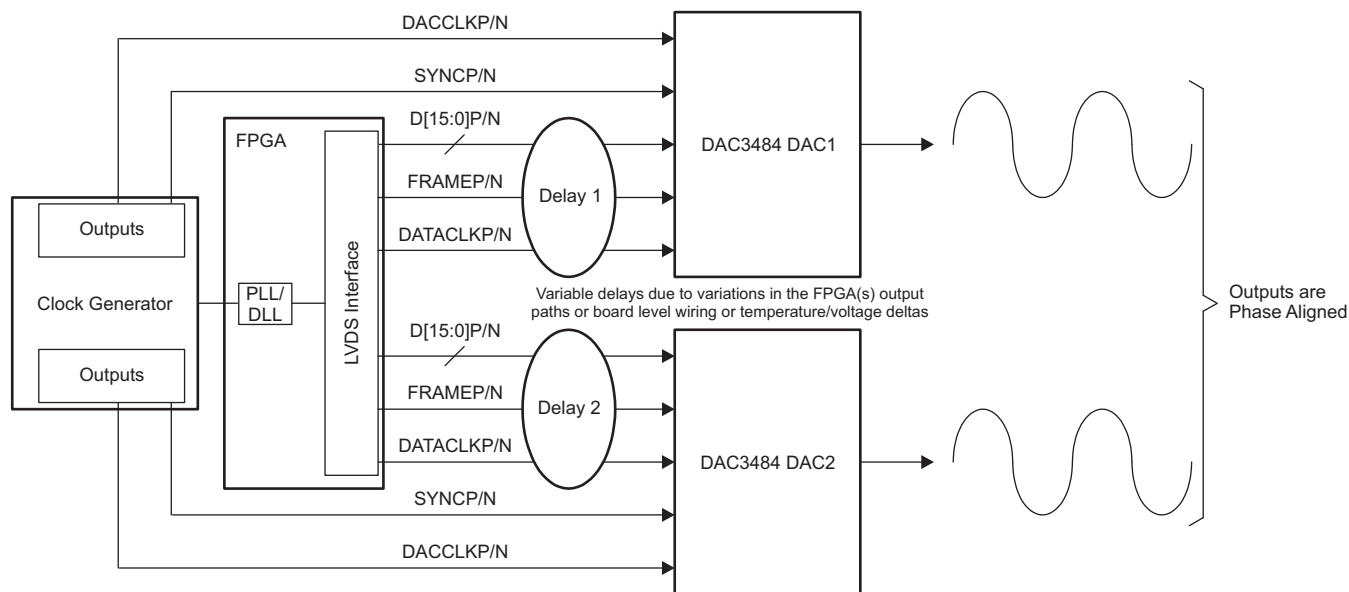

B0455-03

Figure 89. Synchronization System in Dual Sync Sources Mode with PLL Enabled

The following steps are required to ensure the devices are fully synchronized. The procedure assumes all the DAC3484 devices have a DACCLK and SYNC signal and the following steps must be carried out on each device.

1. Start-up the device as described in the power-up sequence. Set the DAC3484 in Dual Sync Sources mode and enable SYNC to reset the PLL dividers (set *pll\_ndivsync\_ena* in register *config24* to 1b).
2. Reset the PLL dividers with a rising edge on SYNC.
3. Disable PLL dividers resetting.
4. Sync the clock divider and FIFO pointers.
5. Verify there are no FIFO alarms either through register *config5* or through the ALARM pin.
6. Disable clock divider sync by setting *clkdiv\_sync\_ena* to 0b in register *config0*.

After these steps all the DAC3484 outputs will be synchronized.

7.4.1.3 Multi-Device Operation: Single Sync Source Mode

In Single Sync Source mode the FIFO read pointer reset is handoff between the two clock domains (DATACLK and FIFO OUT CLOCK) by simply re-sampling the write pointer reset. Since the two clocks are asynchronous there is a small but distinct possibility of a meta-stability during the pointer handoff. As described in the Input FIFO section, this meta-stable situation can change the latency of the multiple DAC devices by both the FIFO Out clock cycles and DAC clock cycles.

When the PLL is enabled with Single Sync Source mode, the FIFO read pointer is not synchronized by the OSTR signal. Therefore, there is no restriction on the PLL PFD frequency as described in the previous section.

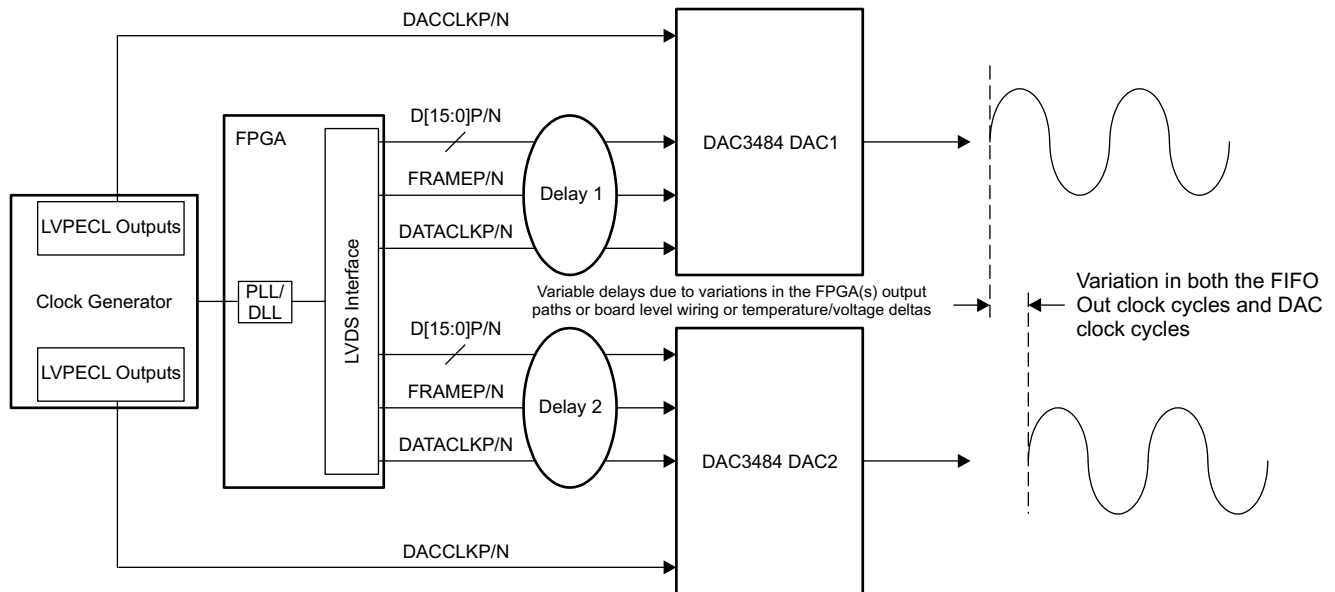
**Device Functional Modes (continued)**

B0456-03

**Figure 90. Multi-Device Operation in Single Sync Source Mode**

## 7.5 Programming

### 7.5.1 Power-Up Sequence

The following startup sequence is recommended to power-up the DAC3484:

1. Set TXENABLE low
2. Supply all 1.2-V voltages (DACVDD, DIGVDD, CLKVDD, and VFUSE) and all 3.3-V voltages (AVDD, IOVDD, and PLLAVDD). The 1.2-V and 3.3-V supplies can be powered up simultaneously or in any order. There are no specific requirements on the ramp rate for the supplies.
3. Provide all LVPECL inputs: DACCLKP/N and the optional OSTRP/N. These inputs can also be provided after the SIF register programming.
4. Toggle the RESETB pin for a minimum 25 ns active low pulse width.
5. Program the SIF registers.
6. Program fuse\_sleep (config27, bit<11>) to put the internal fuses to sleep. To enable dual channel mode, set Config1, bit <8> to 0b and Config16, bit<13:12> to 11b. This dual channel mode is functionally equivalent to the dual channel DAC3484 (channels B and C active). See the DAC3484 [SLAS748](#) datasheet for details.
7. FIFO configuration needed for synchronization:
  - (a) Program *syncsel\_fifoin*(3:0) (config32, bits<15:12>) to select the FIFO input pointer sync source.
  - (b) Program *syncsel\_fifoout*(3:0) (config32, bits<11:8>) to select the FIFO output pointer sync source.
  - (c) Program *syncsel\_dataformatter*(1:0) (config31, bits<3:2>) to select the FIFO Data Formatter sync source.
8. Clock divider configuration needed for synchronization:
  - (a) Program *clkdiv\_sync\_sel* (config32, bit<0>) to select the clock divider sync source.
  - (b) Program *clkdiv\_sync\_ena* (config0, bit<2>) to 1b to enable clock divider sync.
  - (c) For multi-DAC synchronization in PLL mode, program *pll\_ndivsync\_ena* (config24, bit<11>) to 1b to synchronize the PLL N-divider.
9. Provide all LVDS inputs (D[15:0]P/N, DATACLKP/N, FRAMEP/N, SYNCNCP/N, and PARITYP/N) simultaneously. Synchronize the FIFO and clock divider by providing the pulse or periodic signals needed.
  - (a) For Single Sync Source Mode where either FRAMEP/N or SYNCNCP/N is used to sync the FIFO, a single rising edge for FIFO, FIFO data formatter, and clock divider sync is recommended. Periodic sync signal

## Programming (continued)

is not recommended due to the non-deterministic latency of the sync signal through the clock domain transfer.

- (b) For Dual Sync Sources Mode, both single pulse or periodic sync signals can be used.
  - (c) For multi-DAC synchronization in PLL mode, the LVDS SYNC/N signal is used to sync the PLL N-divider and can be sourced from either the FPGA/ASIC pattern generator or clock distribution circuit as long as the  $t_{(\text{SYNC\_PLL})}$  setup and hold timing requirement is met with respect to the reference clock source at DACCLKP/N pins. The LVDS SYNC/N signal can be provided at this point.
10. FIFO and clock divider configurations after all the sync signals have provided the initial sync pulses needed for synchronization:
- (a) For Single Sync Source Mode where the clock divider sync source is either FRAMEP/N or SYNC/N, clock divider syncing may be disabled after DAC3484 initialization and before the data transmission by setting *clkdiv\_sync\_ena* (config0, bit <2>) to 0b. This is to prevent accidental syncing of the clock divider when sending FRAMEP/N or SYNC/N pulse to other digital blocks.
  - (b) For Dual Sync Sources Mode, where the clock divider sync source is from the OSTR signal (either from external OSTRP/N or internal PLL N divider output), the clock divider syncing may be enabled at all time.
  - (c) Optionally, to prevent accidental syncing of the FIFO and FIFO data formatter when sending the FRAMEP/N or SYNC/N pulse to other digital blocks such as NCO, QMC, etc, disable FIFO syncing by setting *syncsel\_fifo*(3:0) and *syncsel\_fifoout*(3:0) to 0000b after the FIFO input and output pointers are initialized. Also Disable the FIFO data formatter by setting *syncsel\_dataformatter*(1:0) to 10b or 11b. If the FIFO and FIFO data formatter sync remain enabled after initialization, the FRAMEP/N or SYNC/N pulse must occur in ways to not disturb the FIFO operation. Refer to the INPUT FIFO section for detail.
  - (d) Disable PLL N-divider syncing by setting *pll\_ndivsync\_ena* (config24, bit<11>) to 0b.
11. Enable transmit of data by asserting the TXENABLE pin or *set\_sif\_txenable* to 1b.
12. At any time, if any of the clocks (i.e DATACLK or DACCLK) is lost or a FIFO collision alarm is detected, a complete resynchronization of the DAC is necessary. Set TXENABLE low and repeat steps 7 through 11. Program the FIFO configuration and clock divider configuration per steps 7 and 8 appropriately to accept the new sync pulse or pulses for the synchronization.

## 7.5.2 Example Start-Up Routine

### 7.5.2.1 Device Configuration

$f_{\text{DATA}} = 307.2 \text{ MSPS}$   
 Interpolation = 4x  
 Input data = baseband data  
 $f_{\text{OUT}} = 122.88 \text{ MHz}$   
 PLL = Enabled  
 Full Mixer = Enabled  
 Dual Sync Sources Mode

### 7.5.2.2 PLL Configuration

$f_{\text{REFCLK}} = 614.4 \text{ MHz}$  at the DACCLKP/N LVPECL pins  
 $f_{\text{DACCLK}} = f_{\text{DATA}} \times \text{Interpolation} = 1228.8 \text{ MHz}$   
 $f_{\text{VCO}} = 3 \times f_{\text{DACCLK}} = 3686.4 \text{ MHz}$  (keep  $f_{\text{VCO}}$  between 3.3 GHz to 4 GHz)  
 $\text{PFD} = f_{\text{OSTR}} = 38.4 \text{ MHz}$   
 $N = 16, M = 32, P = 3$ , single charge pump  
 $\text{pll\_vco}(5:0) = 100100\text{b}$  (36)

## Programming (continued)

### 7.5.2.3 NCO Configuration

$$f_{\text{NCO}} = 122.88 \text{ MHz}$$

$$f_{\text{NCO\_CLK}} = 1228.8 \text{ MHz}$$

$$\text{freq} = f_{\text{NCO}} \times 2^{32} / 1228.8 = 429496730 = 0x1999999A$$

$$\text{phaseaddAB}(31:0) \text{ or } \text{phaseaddCD}(31:0) = 0x19999999A$$

NCO SYNC = rising edge of SYNC

### 7.5.2.4 Example Start-Up Sequence

**Table 10. Example Start-Up Sequence Description**

STEP	READ/WRITE	ADDRESS	VALUE	DESCRIPTION
1	N/A	N/A	N/A	Set TXENABLE Low
2	N/A	N/A	N/A	Power-up the device
3	N/A	N/A	N/A	Apply LVPECL DACCLKP/N for PLL reference clock
4	N/A	N/A	N/A	Toggle RESETB pin
5	Write	0x00	0xF29F	QMC offset and correction enabled, 4x int, FIFO enabled, Alarm enabled, clock divider sync enabled, inverse sinc filter enabled.
6	Write	0x01	0x050E	Single parity enabled, FIFO alarms enabled (2 away, 1 away, and collision).
7	Write	0x02	0xF052	Output shut-off when DACCLK gone, DATACLK gone, and FIFO collision. Mixer block with NCO enabled, twos complement. Word Wide Interface.
8	Write	0x03	0xA000	Output current set to 20mA <sub>FS</sub> with internal reference and 1.28-kΩ R <sub>BIAS</sub> resistor.
9	Write	0x07	0xD8FF	Un-mask FIFO collision, DACCLK-gone, and DATACLK-gone alarms to the Alarm output.
10	Write	0x08	N/A	Program the desired channel A QMC offset value. (Causes Auto-Sync for QMC AB-Channels Offset Block)
11	Write	0x09	N/A	Program the desired FIFO offset value and channel B QMC offset value.
12	Write	0x0A	N/A	Program the desired channel C QMC offset value. (Causes Auto-Sync for QMC CD-Channels Offset Block)
13	Write	0x0B	N/A	Program the desired channel D QMC offset value.
14	Write	0x0C	N/A	Program the desired channel A QMC gain value.
15	Write	0x0D	N/A	Coarse mixer mode not used. Program the desired channel B QMC gain value.
16	Write	0x0E	N/A	Program the desired channel C QMC gain value.
17	Write	0x0F	N/A	Program the desired channel D QMC gain value.
18	Write	0x10	N/A	Program the desired channel AB QMC phase value. (Causes Auto-Sync QMC AB-Channels Correction Block)
19	Write	0x11	N/A	Program the desired channel CD QMC phase value. (Causes Auto-Sync for the QMC CD-Channels Correction Block)
20	Write	0x12	N/A	Program the desired channel AB NCO phase offset value. (Causes Auto-Sync for Channel AB NCO Mixer)
21	Write	0x13	N/A	Program the desired channel CD NCO phase offset value. (Causes Auto-Sync for Channel CD NCO Mixer)
22	Write	0x14	0x999A	Program the desired channel AB NCO frequency value
23	Write	0x15	0x1999	Program the desired channel AB NCO frequency value
24	Write	0x16	0x999A	Program the desired channel CD NCO frequency value
25	Write	0x17	0x1999	Program the desired channel CD NCO frequency value
26	Write	0x18	0x2C58	PLL enabled, PLL N-dividers sync enabled, single charge pump, prescaler = 3.
27	Write	0x19	0x20F4	M = 32, N = 16, PLL VCO bias tune = 01b

**Programming (continued)**
**Table 10. Example Start-Up Sequence Description (continued)**

STEP	READ/WRITE	ADDRESS	VALUE	DESCRIPTION
28	Write	0x1A	0x9000	PLL VCO coarse tune = 36
29	Write	0x1B	0x0800	Internal reference
30	Write	0x1E	0x9999	QMC offset AB, QMC offset CD, QMC correction AB, and QMC correction CD can be synced by <code>sif_sync</code> or auto-sync from register write
31	Write	0x1F	0x4440	Mixer AB and CD values synced by SYNCP/N. NCO accumulator synced by SYNCP/N.
32	Write	0x20	0x2400	FIFO Input Pointer Sync Source = ISTR FIFO Output Pointer Sync Source = OSTR (from PLL N-divider output) Clock Divider Sync Source = OSTR
33	N/A	N/A	N/A	Provide all the LVDS DATA and DATACLK Provide rising edge FRAMEP/N and rising edge SYNCP/N to sync the FIFO input pointer and PLL N-dividers.
34	Read	0x18	N/A	Read back <code>pll_lfvolt(2:0)</code> . If the value is not optimal, adjust <code>pll_vco(5:0)</code> in 0x1A.
35	Write	0x05	0x0000	Clear all alarms in 0x05.
36	Read	0x05	N/A	Read back all alarms in 0x05. Check for PLL lock, FIFO collision, DACCLK-gone, DATACLK-gone, etc. Fix the error appropriately. Repeat step 34 and 35 as necessary.
37	Write	0x1F	0x4442	Sync all the QMC blocks using <code>sif_sync</code> . These blocks can also be synced via auto-sync through appropriate register writes.
38	Write	0x00	0xF29B	Disable clock divider sync.
39	Write	0x1F	0x4448	Set <code>sif_sync</code> to 0b for the next <code>sif_sync</code> event.
40	Write	0x20	0x0000	Disable FIFO input and output pointer sync.
41	Write	0x18	0x2458	Disable PLL N-dividers sync.
42	N/A	N/A	N/A	Set TXENABLE high. Enable data transmission.

**DAC3484**

SLAS749E – MARCH 2011 – REVISED NOVEMBER 2015

[www.ti.com](http://www.ti.com)
**7.6 Register Map**
**Table 11. Register Map<sup>(1)</sup>**

Name	Address	Default	(MSB) Bit 15	Bit 14	Bit 13	Bit 12	Bit 11	Bit 10	Bit 9	Bit 8	Bit 7	Bit 6	Bit 5	Bit 4	Bit 3	Bit 2	Bit 1	(LSB) Bit 0			
config0	0x00	0x049C	qmc_offsetAB_ena	qmc_offsetCD_ena	qmc_corrAB_ena	qmc_corrCD_ena	interp(3:0)				fifo_ena	reserved	reserved	alarm_out_ena	alarm_out_pol	clkdiv_sync_ena	invsincAB_ena	invsincCD_ena			
config1	0x01	0x050E	iotest_ena	reserved	reserved	64cnt_ena	oddeven_parity	word_parity_ena	frame_parity_ena	quad_ena	dacA_complement	dacB_complement	dacC_complement	dacD_complement	alarm_2away_ena	alarm_1away_ena	alarm_collision_ena	reserved			
config2	0x02	0x7000	16bit_in	dacclk_gone_ena	dataclk_gone_ena	collision_gone_ena	reserved	reserved	reserved	reserved	sif4_ena	mixer_ena	mixer_gain	nco_ena	revbus	reserved	twos	reserved			
config3	0x03	0xF000	coarse_dac(3:0)				reserved				reserved				sif_txenable						
config4	0x04	NA	iotest_results(15:0)																		
config5	0x05	0x0000	alarm_from_zerochk	reserved	alarms_from_fifo(2:0)			alarm_dacclk_gone	alarm_dataclk_gone	alarm_output_gone	alarm_from_iotest	reserved	alarm_from_pll	alarm_rparity	alarm_fparity	alarm_frame_parity	reserved	reserved			
config6	0x06	NA	tempdata(7:0)							reserved										reserved	reserved
config7	0x07	0xFFFF	alarms_mask(15:0)																		
config8	0x08	0x0000	reserved	reserved	reserved	qmc_offsetA(12:0)															
config9	0x09	0x8000	fifo_offset(2:0)			qmc_offsetB(12:0)															
config10	0x0A	0x0000	reserved	reserved	reserved	qmc_offsetC(12:0)															
config11	0x0B	0x0000	reserved	reserved	reserved	qmc_offsetD(12:0)															
config12	0x0C	0x0400	reserved	reserved	reserved	reserved	reserved	qmc_gainA(10:0)													
config13	0x0D	0x0400	cmix(3:0)				reserved	qmc_gainB(10:0)													
config14	0x0E	0x0400	reserved	reserved	reserved	reserved	reserved	qmc_gainC(10:0)													
config15	0x0F	0x0400	output_delayAB(1:0)		output_delayCD(1:0)		reserved	qmc_gainD(10:0)													
config16	0x10	0x0000	reserved	reserved	dual_ena(1:0)		qmc_phaseAB(11:0)														
config17	0x11	0x0000	reserved	reserved	reserved	reserved	qmc_phaseCD(11:0)														
config18	0x12	0x0000	phase_offsetAB(15:0)																		
config19	0x13	0x0000	phase_offsetCD(15:0)																		
config20	0x14	0x0000	phase_addAB(15:0)																		
config21	0x15	0x0000	phase_addAB(31:16)																		
config22	0x16	0x0000	phase_addCD(15:0)																		
config23	0x17	0x0000	phase_addCD(31:16)																		
config24	0x18	NA	reserved			pll_reset	pll_ndivsync_ena	pll_ena	reserved			pll_cp(1:0)	pll_p(2:0)			pll_lfvolt(2:0)					
config25	0x19	0x0440	pll_m(7:0)							pll_n(3:0)					pll_vcoitune(2:0)		reserved				
config26	0x1A	0x0020	pll_vco(5:0)					reserved	reserved	bias_sleep	tsense_sleep	pll_sleep	clkrecv_sleep	sleepA	sleepB	sleepC	sleepD				
config27	0x1B	0x0000	extref_ena	reserved	reserved	reserved	fuse_sleep	reserved	reserved	reserved	reserved	reserved	reserved								

(1) Unless otherwise noted, all reserved registers should be programmed to default values.

Register Map (continued)

Table 11. Register Map<sup>(1)</sup> (continued)

Name	Address	Default	(MSB) Bit 15	Bit 14	Bit 13	Bit 12	Bit 11	Bit 10	Bit 9	Bit 8	Bit 7	Bit 6	Bit 5	Bit 4	Bit 3	Bit 2	Bit 1	(LSB) Bit 0	
config28	0x1C	0x0000	reserved								reserved								
config29	0x1D	0x0000	reserved								reserved								
config30	0x1E	0x1111	syncsel_qmoffsetAB(3:0)				syncsel_qmoffsetCD(3:0)				syncsel_qmcorrAB(3:0)				syncsel_qmcorCD(3:0)				
config31	0x1F	0x1140	syncsel_mixerAB(3:0)				syncsel_mixerCD(3:0)				syncsel_nco(3:0)				syncsel_dataformatter	sif_sync	reserved		
config32	0x20	0x2400	syncsel_fifoain(3:0)				syncsel_fifoout(3:0)				reserved								clkdiv_sync_sel
config33	0x21	0x0000	reserved																
config34	0x22	0x1B1B	pathA_in_sel(1:0)	pathB_in_sel(1:0)	pathC_in_sel(1:0)	pathD_in_sel(1:0)	DACA_out_sel(1:0)		DACB_out_sel(1:0)		DACC_out_sel(1:0)		DACD_out_sel(1:0)						
config35	0x23	0xFFFF	sleep_cntl(15:0)																
config36	0x24	0x0000	datadly(2:0)				clkdly(2:0)				reserved								
config37	0x25	0x7A7A	iostest_pattern0																
config38	0x26	0xB6B6	iostest_pattern1																
config39	0x27	0xEAEA	iostest_pattern2																
config40	0x28	0x4545	iostest_pattern3																
config41	0x29	0x1A1A	iostest_pattern4																
config42	0x2A	0x1616	iostest_pattern5																
config43	0x2B	0xAAAA	iostest_pattern6																
config44	0x2C	0xC6C6	iostest_pattern7																
config45	0x2D	0x0004	reserved	ostrtodig_sel	ramp_ena	reserved											sifdac_ena		
config46	0x2E	0x0000	grp_delayA(7:0)								grp_delayB(7:0)								
config47	0x2F	0x0000	grp_delayC(7:0)								grp_delayD(7:0)								
config48	0x30	0x0000	sifdac(15:0)																
version	0x7F	0x540C	reserved						reserved	reserved	reserved	reserved	deviceid(1:0)		versionid(2:0)				

**7.6.1 Register Descriptions**
**Table 12. Register Name: config0 – Address: 0x00, Default: 0x049C**

Register Name	Address	Bit	Name	Function	Default Value	
config0	0x00	15	qmc_offsetAB_ena	When set, the digital Quadrature Modulator Correction (QMC) offset correction for the AB data path is enabled.	0	
		14	qmc_offsetCD_ena	When set, the digital Quadrature Modulator Correction (QMC) offset correction for the CD data path is enabled.	0	
		13	qmc_corrAB_ena	When set, the QMC phase and gain correction circuitry for the AB data path is enabled.	0	
		12	qmc_corrCD_ena	When set, the QMC phase and gain correction circuitry for the CD data path is enabled.	0	
		11:8	interp(3:0)	These bits define the interpolation factor	0100	
				<b>interp</b>	<b>Interpolation Factor</b>	
				0000	1x	
				0001	2x	
				0010	4x	
				0100	8x	
				1000	16x	
		7	fifo_ena	When set, the FIFO is enabled. <b>When the FIFO is disabled, DACCLKP/N and DATACLKP/N must be aligned (not recommended).</b>	1	
		6	Reserved	Reserved for factory use.	0	
		5	Reserved	Reserved for factory use.	0	
4	alarm_out_ena	When set, the ALARM pin becomes an output. When cleared, the ALARM pin is 3-stated.	1			
3	alarm_out_pol	This bit changes the polarity of the ALARM signal. 0: Negative logic 1: Positive logic	1			
2	clkdiv_sync_ena	When set, enables the syncing of the clock divider using the sync source selected by register <i>config32</i> . The internal divided-down clocks will be phase aligned after syncing. Refer to the <a href="#">Power-Up Sequence</a> section for more detail.	1			
1	invsincAB_ena	When set, the inverse sinc filter for the AB data is enabled.	0			
0	invsincCD_ena	When set, the inverse sinc filter for the CD data is enabled.	0			

**Table 13. Register Name: config1 – Address: 0x01, Default: 0x050E**

Register Name	Address	Bit	Name	Function	Default Value
config1	0x01	15	iotest_ena	When set, enables the data pattern checker test. <b>The outputs are deactivated regardless of the state of TXENABLE and sif_txenable.</b>	0
		14	Reserved	Reserved for factory use.	0
		13	Reserved	Reserved for factory use.	0
		12	64cnt_ena	When set, enables resetting of the alarms after 64 good samples with the goal of removing unnecessary errors. For instance, when checking setup/hold through the pattern checker test, there may initially be errors. Setting this bit removes the need for a SIF write to clear the alarm register.	0
		11	oddeven_parity	Selects between odd and even parity check 0: Even parity 1: Odd parity	0
		10	word_parity_ena	When set, enables parity checking of each input word using the PARITYP/N parity input. It should match the <b>oddeven_parity</b> register setting.	1
		9	frame_parity_ena	When set, enables parity checking using the FRAME signal to source the parity bit.	0
		8	quad_ena	When set, the device is in quad channel mode. To enable the dual channel mode, set Config1, bit <8> to 0b and Config16, bit<13:12> to 11b. This dual channel mode is functionally equivalent to the dual channel DAC3484 (channels B and C active). See the DAC3484 SLAS748 datasheet for details.	1
		7	dacA_complement	When set, the DACA output is complemented. This allows to effectively change the + and – designations of the LVDS data lines.	0
		6	dacB_complement	When set, the DACB output is complemented. This allows to effectively change the + and – designations of the LVDS data lines.	0
		5	dacC_complement	When set, the DACC output is complemented. This allows to effectively change the + and – designations of the LVDS data lines.	0
		4	dacD_complement	When set, the DACD output is complemented. This allows to effectively change the + and – designations of the LVDS data lines.	0
		3	alarm_2away_ena	When set, the alarm from the FIFO indicating the write and read pointers being 2 away is enabled.	1
		2	alarm_1away_ena	When set, the alarm from the FIFO indicating the write and read pointers being 1 away is enabled.	1
		1	alarm_collision_ena	When set, the alarm from the FIFO indicating a collision between the write and read pointers is enabled.	1
0	Reserved	Reserved for factory use.	0		

**Table 14. Register Name: config2 – Address: 0x02, Default: 0x7000**

Register Name	Address	Bit	Name	Function	Default Value
config2	0x02	15	16bit_in	When set, the input interface is set to word-wide mode. When cleared, the input interface is set to byte-wide mode.	0
		14	dacclkgone_ena	When set, the DACCLK-gone signal from the clock monitor circuit can be used to shut off the DAC outputs. The corresponding alarms, <i>alarm_dacclk_gone</i> and <i>alarm_output_gone</i> , must not be masked (i.e. Config7, bit <10> and bit <8> must set to 0b).	1
		13	dataclkgone_ena	When set, the DATACLK-gone signal from the clock monitor circuit can be used to shut off the DAC outputs. The corresponding alarms, <i>alarm_dataclk_gone</i> and <i>alarm_output_gone</i> , must not be masked (i.e. Config7, bit <9> and bit <8> must set to 0b).	1
		12	collisiongone_ena	When set, the FIFO collision alarms can be used to shut off the DAC outputs. The corresponding alarms, <i>alarm_fifo_collision</i> and <i>alarm_output_gone</i> , must not be masked (i.e. Config7, bit <13> and bit <8> must set to 0b).	1
		11	Reserved	Reserved for factory use.	0
		10	Reserved	Reserved for factory use.	0
		9	Reserved	Reserved for factory use.	0
		8	Reserved	Reserved for factory use.	0
		7	sif4_ena	When set, the serial interface (SIF) is a 4 bit interface, otherwise it is a 3-bit interface.	0
		6	mixer_ena	When set, the mixer block is enabled.	0
		5	mixer_gain	When set, a 6dB gain is added to the mixer output.	0
		4	nco_ena	When set, the NCO is enabled. This is not required for coarse mixing.	0
		3	revbus	When set, the input bits for the data bus are reversed. MSB becomes LSB.	0
		2	Reserved	Reserved for factory use.	0
		1	twos	When set, the input data format is expected to be 2s complement. When cleared, the input is expected to be offset-binary.	0
0	Reserved	Reserved for factory use.	0		

**Table 15. Register Name: config3 – Address: 0x03, Default: 0xF000**

Register Name	Address	Bit	Name	Function	Default Value
config3	0x03	15:12	coarse_dac(3:0)	Scales the output current in 16 equal steps. $I_{FS} = \frac{V_{EXTIO}}{R_{BIAS}} \times 2 \times (\text{coarse\_dac} + 1)$	1111
		11:8	Reserved	Reserved for factory use.	0000
		7:1	Reserved	Reserved for factory use.	0000000
		0	sif_txenable	When set, the internal value of TXENABLE is set to 1b. To enable analog output data transmission, set <i>sif_txenable</i> to 1b or pull CMOS TXENABLE pin (A32 for DAC3484IRKD and N9 for DAC3484IZAY) to high. To disable analog output, set <i>sif_txenable</i> to 0b and pull CMOS TXENABLE pin (A32 for DAC3484IRKD and N9 for DAC3484IZAY) to low.	0

**Table 16. Register Name: config4 – Address: 0x04, Default: No RESET Value (Write to Clear)**

Register Name	Address	Bit	Name	Function	Default Value
config4	0x04	15:0	iotest_results(15:0)	This register is used with pattern checker test enabled ( <i>iotest_ena</i> in <i>config1</i> , bit <15> set to 1b). It does not have a default RESET value. The values of these bits tell which bit in the word failed during the pattern checker test. <i>iotest_results</i> (15:8) correspond to the data bits on D[15:8] and <i>iotest_results</i> (7:0) correspond to the data bits on D[7:0].	No RESET Value

**Table 17. Register Name: config5 – Address: 0x05, Default: Setup and Power-Up Conditions Dependent (Write to Clear)**

Register Name	Address	Bit	Name	Function	Default Value
config5	0x05	15	alarm_from_zerock	This alarm indicates the 8-bit FIFO write pointer address has an all zeros patterns. Due to pointer address being a shift register, this is not a valid address and will cause the write pointer to be stuck until the next sync. This error is typically caused by timing error or improper power start-up sequence. If this alarm is asserted, resynchronization of FIFO is necessary. See Power-Up Sequence for more detail.	NA
		14	Reserved	Reserved for factory use.	NA
		13:11	alarms_from_fifo(2:0)	Alarm indicating FIFO pointer collisions and nearness: 000: All fine 001: Pointers are 2 away 01x: Pointers are 1 away 1xx: FIFO pointer collision If the FIFO pointer collision alarm is set when <i>collisiogone_ena</i> is enabled, the FIFO must be re-synchronized and the bits must be cleared to resume normal operation.	NA
		10	alarm_dacclk_gone	Alarm indicating the DACCLK has been stopped. If the bit is set when <i>dacclkgone_ena</i> is enabled, the DACCLK must resume and the bit must be cleared to resume normal operation.	NA
		9	alarm_dataclk_gone	Alarm indicating the DATACLK has been stopped. If the bit is set when <i>dataclkgone_ena</i> is enabled, the DATACLK must resume and the bit must be cleared to resume normal operation.	NA
		8	alarm_output_gone	Alarm indicating either <i>alarm_dacclk_gone</i> , <i>alarm_dataclk_gone</i> , or <i>alarm_fifo_collision</i> are asserted. It controls the output. When high it will output 0x8000 for each output connected to the DAC. If the bit is set when <i>dacclkgone_ena</i> , <i>dataclkgone_ena</i> , or <i>collisiogone_ena</i> are enabled, then the corresponding errors must be fixed and the bits must be cleared to resume normal operation.	NA
		7	alarm_from_iotest	Alarm indicating the input data pattern does not match the pattern in the <i>iotest_pattern</i> registers. When data pattern checker mode is enabled, this alarm in register config5, bit7 is the only valid alarm. Other alarms in register config5 are not valid and can be disregarded.	NA
		6	Reserved	Reserved for factory use.	NA
		5	alarm_from_pll	Alarm indicating the PLL has lost lock. For version ID 100b or earlier, <i>alarm_from_PLL</i> may not indicate the correct status of the PLL. Refer to <i>pll_lfvolt(2:0)</i> in register config24 for proper PLL lock indication.	NA
		4	alarm_rparity	Alarm indicating a parity error on data captured on the rising edge of DATACLKP/N.	NA
		3	alarm_fparity	Alarm indicating a parity error on data captured on the falling edge of DATACLKP/N.	NA
		2	alarm_frame_parity	Alarm indicating a parity error when using the FRAME as parity bit.	NA
		1	Reserved	Reserved for factory use.	NA
0	Reserved	Reserved for factory use.	NA		

**Table 18. Register Name: config6 – Address: 0x06, Default: No RESET Value (Read Only)**

Register Name	Address	Bit	Name	Function	Default Value
config6	0x06	15:8	tempdata(7:0)	This is the output from the chip temperature sensor. The value of this register in two's complement format represents the temperature in degrees Celsius. <b>This register must be read with a minimum SCLK period of 1 <math>\mu</math>s.</b>	No RESET Value
		7:2	Reserved	Reserved for factory use.	000000
		1	Reserved	Reserved for factory use.	0
		0	Reserved	Reserved for factory use.	0

**Table 19. Register Name: config7 – Address: 0x07, Default: 0xFFFF**

Register Name	Address	Bit	Name	Function	Default Value			
config7	0x07	15:0	alarms_mask(15:0)	These bits control the masking of the alarms. (0 = not masked, 1 = masked)		0xFFFF		
				<b>alarm_mask</b>			<b>Alarm that is Masked</b>	
				15	alarm_from_zerock			
				14	not used			
				13	alarm_fifo_collision			
				12	alarm_fifo_1away			
				11	alarm_fifo_2away			
				10	alarm_dacclk_gone			
				9	alarm_dataclk_gone			
				8	alarm_output_gone			
				7	alarm_from_iotest			
				6	not used			
				5	alarm_from_pll			
				4	alarm_rparity			
				3	alarm_fparity			
				2	alarm_frame_parity			
1	not used							
0	not used							

**Table 20. Register Name: config8 – Address: 0x08, Default: 0x0000 (Causes Auto-Sync)**

Register Name	Address	Bit	Name	Function	Default Value
config8	0x08	15	Reserved	Reserved for factory use.	0
		14	Reserved	Reserved for factory use.	0
		13	Reserved	Reserved for factory use.	0
		12:0	qmc_offsetA(12:0)	DACA offset correction. The offset is measured in DAC LSBs. <b>If enabled in config30 writing to this register causes an auto-sync to be generated. This loads the values of the QMC offset registers (config8-config9) into the offset block at the same time. When updating the offset values for AB channel config8 should be written last. Programming config9 will not affect the offset setting.</b>	All zeros

**Table 21. Register Name: config9 – Address: 0x09, Default: 0x8000**

Register Name	Address	Bit	Name	Function	Default Value
config9	0x09	15:13	fifo_offset(2:0)	When the sync to the FIFO occurs, this is the value loaded into the FIFO read pointer. With this value the initial difference between write and read pointers can be controlled. This may be helpful in syncing multiple chips or controlling the delay through the device.	100
		12:0	qmc_offsetB(12:0)	DACB offset correction. The offset is measured in DAC LSBs.	All zeros

**Table 22. Register Name: config10 – Address: 0x0A, Default: 0x0000 (Causes Auto-Sync)**

Register Name	Address	Bit	Name	Function	Default Value
config10	0x0A	15	Reserved	Reserved for factory use.	0
		14	Reserved	Reserved for factory use.	0
		13	Reserved	Reserved for factory use.	0
		12:0	qmc_offsetC(12:0)	DACC offset correction. The offset is measured in DAC LSBs. <b>If enabled in config30 writing to this register causes an auto-sync to be generated. This loads the values of the CD-channel QMC offset registers (config10-config11) into the offset block at the same time. When updating the offset values for the CD-channel config10 should be written last. Programming config11 will not affect the offset setting.</b>	All zeros

**Table 23. Register Name: config11 – Address: 0x0B, Default: 0x0000**

Register Name	Address	Bit	Name	Function	Default Value
config11	0x0B	15	Reserved	Reserved for factory use.	0
		14	Reserved	Reserved for factory use.	0
		13	Reserved	Reserved for factory use.	0
		12:0	qmc_offsetD(12:0)	DACD offset correction. The offset is measured in DAC LSBs.	All zeros

**Table 24. Register Name: config12 – Address: 0x0C, Default: 0x0400**

Register Name	Address	Bit	Name	Function	Default Value
config12	0x0C	15	Reserved	Reserved for factory use.	0
		14	Reserved	Reserved for factory use.	0
		13	Reserved	Reserved for factory use.	0
		12	Reserved	Reserved for factory use.	0
		11	Reserved	Reserved for factory use.	0
		10:0	qmc_gainA(10:0)	QMC gain for DACA. The full 11-bit qmc_gainA(10:0) word is formatted as UNSIGNED with a range of 0 to 1.9990. The implied decimal point for the multiplication is between bit 9 and bit 10.	10000000 000

**Table 25. Register Name: config13 – Address: 0x0D, Default: 0x0400**

Register Name	Address	Bit	Name	Function	Default Value
config13	0x0D	15	cmix_mode(3:0)	Sets the mixing function of the coarse mixer. Bit 15: Fs/8 mixer Bit 14: Fs/4 mixer Bit 13: Fs/2 mixer Bit 12: -Fs/4 mixer The various mixers can be combined together to obtain a $\pm n \times F_s/8$ total mixing factor.	0000
		11	Reserved	Reserved for factory use.	0
		10:0	qmc_gainB(10:0)	QMC gain for DACB. The full 11-bit qmc_gainB(10:0) word is formatted as UNSIGNED with a range of 0 to 1.9990. The implied decimal point for the multiplication is between bit 9 and bit 10.	10000000 000

**Table 26. Register Name: config14 – Address: 0x0E, Default: 0x0400**

Register Name	Address	Bit	Name	Function	Default Value
config14	0x0E	15	Reserved	Reserved for factory use.	0
		14	Reserved	Reserved for factory use.	0
		13	Reserved	Reserved for factory use.	0
		12	Reserved	Reserved for factory use.	0
		11	Reserved	Reserved for factory use.	0
		10:0	qmc_gainC(10:0)	QMC gain for DACC. The 11-bit qmc_gainC(10:0) word is formatted as UNSIGNED with a range of 0 to 1.9990. The implied decimal point for the multiplication is between bit 9 and bit 10.	10000000 000

**Table 27. Register Name: config15 – Address: 0x0F, Default: 0x0400**

Register Name	Address	Bit	Name	Function	Default Value
config15	0x0F	15:14	output_delayAB(1:0)	Delays the AB data path outputs from 0 to 3 DAC clock cycles.	00
		13:12	output_delayCD(1:0)	Delays the CD data path outputs from 0 to 3 DAC clock cycles.	00
		11	Reserved	Reserved for factory use.	0
		10:0	qmc_gainD(10:0)	QMC gain for DACD. The full 11-bit qmc_gainD(10:0) word is formatted as UNSIGNED with a range of 0 to 1.9990. The implied decimal point for the multiplication is between bit 9 and bit 10.	10000000 000

**Table 28. Register Name: config16 – Address: 0x10, Default: 0x0000 (Causes Auto-Sync)**

Register Name	Address	Bit	Name	Function	Default Value
config16	0x10	15	Reserved	Reserved for factory use.	0
		14	Reserved	Reserved for factory use.	0
		13:12	dual_ena (1:0)	To enable the dual channel mode, set Config1, bit <8> to 0b and Config16, bit<13:12> to 11b. This dual channel mode is functionally equivalent to the dual channel DAC3484 (channels B and C active). See the DAC3482 <a href="#">SLAS748</a> data sheet for details.	0
		11:0	qmc_phaseAB(11:0)	QMC correction phase for the AB data path. The 12-bit qmc_phaseAB(11:0) word is formatted as 2s complement and scaled to occupy a range of –0.5 to 0.49975 and a default phase correction of 0.00. To accomplish QMC phase correction, this value is multiplied by the current B sample, then summed into the A sample. <b>If enabled in config30 writing to this register causes an auto-sync to be generated. This loads the values of the QMC correction registers (config12, config13, and config16) into the QMC block at the same time. When updating the QMC values for the AB channel config16 should be written last. Programming config12 and config13 will not affect the QMC settings.</b>	All zeros

**Table 29. Register Name: config17 – Address: 0x11, Default: 0x0000 (Causes Auto-Sync)**

Register Name	Address	Bit	Name	Function	Default Value
config17	0x11	15	Reserved	Reserved for factory use.	0
		14	Reserved	Reserved for factory use.	0
		13	Reserved	Reserved for factory use.	0
		12	Reserved	Reserved for factory use.	0
		11:0	qmc_phaseCD(11:0)	QMC correction phase for the CD data path. The 12-bit qmc_phaseCD(11:0) word is formatted as 2s complement and scaled to occupy a range of –0.5 to 0.49975 and a default phase correction of 0.00. To accomplish QMC phase correction, this value is multiplied by the current D sample, then summed into the C sample. <b>If enabled in config30 writing to this register causes an auto-sync to be generated. This loads the values of the CD-channel QMC block registers (config14, config15, and config17) into the QMC block at the same time. When updating the QMC values for the CD-channel config17 should be written last. Programming config14 and config15 will not affect the QMC settings.</b>	All zeros

**Table 30. Register Name: config18 – Address: 0x12, Default: 0x0000 (Causes Auto-Sync)**

Register Name	Address	Bit	Name	Function	Default Value
config18	0x12	15:0	phase_offsetAB(15:0)	Phase offset added to the AB data path NCO accumulator before the generation of the SIN and COS values. The phase offset is added to the upper 16 bits of the NCO accumulator results and these 16 bits are used in the sin/cos lookup tables. <b>If enabled in config31 writing to this register causes an auto-sync to be generated. This loads the values of the fine mixer block registers (config18, config20, and config21) at the same time. When updating the mixer values the config18 should be written last. Programming config20 and config21 will not affect the mixer settings.</b>	0x0000

**Table 31. Register Name: config19 – Address: 0x13, Default: 0x0000 (Causes Auto-Sync)**

Register Name	Address	Bit	Name	Function	Default Value
config19	0x13	15:0	phase_offsetCD(15:0)	Phase offset added to the CD data path NCO accumulator before the generation of the SIN and COS values. The phase offset is added to the upper 16 bits of the NCO accumulator results and these 16 bits are used in the sin/cos lookup tables. <b>If enabled in config31 writing to this register causes an auto-sync to be generated. This loads the values of the CD-channel fine mixer block registers (config19, config22 and config23) at the same time. When updating the mixer values for the CD-channel config19 should be written last. Programming config22 and config23 will not affect the mixer settings.</b>	0x0000

**Table 32. Register Name: config20 – Address: 0x14, Default: 0x0000**

Register Name	Address	Bit	Name	Function	Default Value
config20	0x14	15:0	phase_addAB(15:0)	The phase_addAB(15:0) value is used to determine the NCO frequency. The 2s complement formatted value can be positive or negative. Each LSB represents $F_s/(2^{32})$ frequency step.	0x0000

**Table 33. Register Name: config21 – Address: 0x15, Default: 0x0000**

Register Name	Address	Bit	Name	Function	Default Value
config21	0x15	15:0	phase_addAB(31:16)	See <i>config20</i> above.	0x0000

**Table 34. Register Name: config22 – Address: 0x16, Default: 0x0000**

Register Name	Address	Bit	Name	Function	Default Value
config22	0x16	15:0	phase_addCD(15:0)	The phase_addCD(15:0) value is used to determine the NCO frequency. The 2s complement formatted value can be positive or negative. Each LSB represents $F_s/(2^{32})$ frequency step.	0x0000

**Table 35. Register Name: config23 – Address: 0x17, Default: 0x0000**

Register Name	Address	Bit	Name	Function	Default Value
config23	0x17	15:0	phase_addCD(31:16)	See <i>config22</i> above.	0x0000

**Table 36. Register Name: config24 – Address: 0x18, Default: NA**

Register Name	Address	Bit	Name	Function	Default Value
config24	0x18	15:13	Reserved	Reserved for factory use.	001
		12	pll_reset	When set, the PLL loop filter (LPF) is pulled down to 0 V. Toggle from 1b to 0b to restart the PLL if an over-speed lock-up occurs. Over-speed can happen when the process is fast, the supplies are higher than nominal, etc. resulting in the feedback dividers missing a clock.	0
		11	pll_ndivsync_ena	When set, the LVDS SYNC input is used to sync the PLL N dividers.	1
		10	pll_ena	When set, the PLL is enabled. When cleared, the PLL is bypassed.	0
		9:8	Reserved	Reserved for factory use.	00
		7:6	pll_cp(1:0)	PLL pump charge select 00: No charge pump 01: Single pump charge 10: Not used 11: Dual pump charge	00
		5:3	pll_p(2:0)	PLL pre-scaler dividing module control. 010: 2 011: 3 100: 4 101: 5 110: 6 111: 7 000: 8	001
		2:0	pll_lfvolt(2:0)	PLL loop filter voltage. This three bit read-only indicator has step size of 0.4125 V. The entire range covers from 0 V to 3.3 V. The optimal lock range of the PLL will be from 010 to 101 (0.825 V to 2.063 V). Adjust pll_vco(5:0) for optimal lock range.	NA

**Table 37. Register Name: config25 – Address: 0x19, Default: 0x0440**

Register Name	Address	Bit	Name	Function	Default Value
config25	0x19	15:8	pll_m(7:0)	M portion of the M/N divider of the PLL. If pll_m<7> = 0, the M divider value has the range of pll_m<6:0>, spanning from 4 to 127. (0, 1, 2, and 3 are not valid.) If pll_m<7> = 1, the M divider value has the range of 2 × pll_m<6:0>, spanning from 8 to 254. (0, 2, 4, and 6 are not valid. M divider has even values only.)	0x04
		7:4	pll_n(3:0)	N portion of the M/N divider of the PLL. 0000: 1 0001: 2 0010: 3 0011: 4 0100: 5 0101: 6 0110: 7 0111: 8 1000: 9 1001: 10 1010: 11 1011: 12 1100: 13 1101: 14 1110: 15 1111: 16	0100
		3:2	pll_vcoitune(1:0)	PLL VCO bias tuning bits. Set to 01b for normal PLL operation.	00
		1:0	Reserved	Reserved for factory use.	00

**Table 38. Register Name: config26 – Address: 0x1A, Default: 0x0020**

Register Name	Address	Bit	Name	Function	Default Value
config26	0x1A	15:10	pll_vco(5:0)	VCO frequency coarse tuning bits.	000000
		9	Reserved	Reserved for factory use.	0
		8	Reserved	Reserved for factory use.	0
		7	bias_sleep	When set, the bias amplifier is put into sleep mode.	0
		6	tsense_sleep	Turns off the temperature sensor when asserted.	0
		5	pll_sleep	When set, the PLL is put into sleep mode.	1
		4	clkrecv_sleep	When asserted the clock input receiver gets put into sleep mode. This affects the OSTR receiver as well.	0
		3	sleepA	When set, the DACA is put into sleep mode.	0
		2	sleepB	When set, the DACB is put into sleep mode.	0
		1	sleepC	When set, the DACC is put into sleep mode.	0
0	sleepD	When set, the DACD is put into sleep mode.	0		

**Table 39. Register Name: config27 – Address: 0x1B, Default: 0x0000**

Register Name	Address	Bit	Name	Function	Default Value		
config27	0x1B	15	extref_ena	Allows the device to use an external reference or the internal reference. 0: Internal reference 1: External reference	0		
		14	Reserved	Reserved for factory use.	0		
		13	Reserved	Reserved for factory use.	0		
		12	Reserved	Reserved for factory use.	0		
		11	fuse_sleep	Put the fuses to sleep when set high. If SLEEP pin is set to logic HIGH before and during device power-up and initialization, the fuse_sleep bit in register 0x1B, bit 11 must be written after register 0x23 during device initialization register setup. <b>Note: Default value is '0'. Must be set to '1' for proper operation</b>	0		
		10	Reserved	Reserved for factory use.	0		
		9	Reserved	Reserved for factory use.	0		
		8	Reserved	Reserved for factory use.	0		
		7	Reserved	Reserved for factory use.	0		
		6	Reserved	Reserved for factory use.	0		
		5:0	atest	ATEST mode allows the user to check for the internal die voltages to ensure the supply voltages are within the range. When ATEST mode is programmed, the internal die voltages can be measured at the TXENABLE pin. The TXENABLE pin (A32) must be floating without any pull-up or pull-down resistors. In ATEST mode, the TXENABLE and sif_txenable logics are bypassed, and output will be active at all time.			000000
		<b>Config27, bit&lt;5:0&gt;</b>		<b>Description</b>	<b>Expected Nominal Voltage</b>		
		001110		DACA AVSS	0 V		
		001111		DACA DVDD	1.2 V		
		010000		DACA AVDD	3.3 V		
		010110		DACB AVSS	0 V		
010111		DACB DVDD	1.2 V				
011000		DACB AVDD	3.3 V				
011110		DACC AVSS	0 V				
011111		DACC DVDD	1.2 V				
100000		DACC AVDD	3.3 V				
100110		DACD AVSS	0 V				
100111		DACD DVDD	1.2 V				
101000		DACD AVDD	3.3 V				
110000		DIGVDD	1.2 V				
000101		CLKVDD	1.2 V				

**Table 40. Register Name: config28 – Address: 0x1C, Default: 0x0000**

Register Name	Address	Bit	Name	Function	Default Value
config28	0x1C	15:8	Reserved	Reserved for factory use.	0x00
		7:0	Reserved	Reserved for factory use.	0x00

**Table 41. Register Name: config29 – Address: 0x1D, Default: 0x0000**

Register Name	Address	Bit	Name	Function	Default Value
config29	0x1D	15:8	Reserved	Reserved for factory use.	0x00
		7:0	Reserved	Reserved for factory use.	0x00

**Table 42. Register Name: config30 – Address: 0x1E, Default: 0x1111**

Register Name	Address	Bit	Name	Function	Default Value
config30	0x1E	15:12	syncsel_qmoffsetAB(3:0)	Selects the syncing source(s) of the AB data path double buffered QMC offset registers. A 1b in the bit enables the signal as a sync source. More than one sync source is permitted. Bit 15: sif_sync (via config31) Bit 14: SYNC Bit 13: OSTR Bit 12: Auto-sync from register write	0001
		11:8	syncsel_qmoffsetCD(3:0)	Selects the syncing source(s) of the CD data path double buffered QMC offset registers. A 1b in the bit enables the signal as a sync source. More than one sync source is permitted. Bit 11: sif_sync (via config31) Bit 10: SYNC Bit 9: OSTR Bit 8: Auto-sync from register write	0001
		7:4	syncsel_qmccorrAB(3:0)	Selects the syncing source(s) of the AB data path double buffered QMC correction registers. A '1' in the bit enables the signal as a sync source. More than one sync source is permitted. Bit 7: sif_sync (via config31) Bit 6: SYNC Bit 5: OSTR Bit 4: Auto-sync from register write	0001
		3:0	syncsel_qmccorrCD(3:0)	Selects the syncing source(s) of the CD data path double buffered QMC correction registers. A 1b in the bit enables the signal as a sync source. More than one sync source is permitted. Bit 3: sif_sync (via config31) Bit 2: SYNC Bit 1: OSTR Bit 0: Auto-sync from register write	0001

**Table 43. Register Name: config31 – Address: 0x1F, Default: 0x1140**

Register Name	Address	Bit	Name	Function	Default Value
config31	0x1F	15:12	syncsel_mixerAB(3:0)	Selects the syncing source(s) of the AB data path double buffered mixer registers. A 1b in the bit enables the signal as a sync source. More than one sync source is permitted. Bit 15: sif_sync (via config31) Bit 14: SYNC Bit 13: OSTR Bit 12: Auto-sync from register write	0001
		11:8	syncsel_mixerCD(3:0)	Selects the syncing source(s) of the CD data path double buffered mixer registers. A 1b in the bit enables the signal as a sync source. More than one sync source is permitted. Bit 11: sif_sync (via config31) Bit 10: SYNC Bit 9: OSTR Bit 8: Auto-sync from register write	0001
		7:4	syncsel_nco(3:0)	Selects the syncing source(s) of the two NCO accumulators. A 1b in the bit enables the signal as a sync source. More than one sync source is permitted. Bit 7: sif_sync (via config31) Bit 6: SYNC Bit 5: OSTR Bit 4: FRAME	0100
		3:2	syncsel_dataformatter(1:0)	Selects the syncing source of the data formatter. Unlike the other syncs only one sync source is allowed. 00: FRAME 01: SYNC 10: No sync 11: No sync	00
		1	sif_sync	SIF created sync signal. Set to 1b to cause a sync and then clear to 0b to remove it.	0
		0	Reserved	Reserved for factory use.	0

**Table 44. Register Name: config32 – Address: 0x20, Default: 0x2400**

Register Name	Address	Bit	Name	Function	Default Value
config32	0x20	15:12	syncsel_fifoIn(3:0)	Selects the syncing source(s) of the FIFO input side. A '1' in the bit enables the signal as a sync source. More than one sync source is permitted. Bit 15: sif_sync (via config31) Bit 14: Always zero Bit 13: FRAME Bit 12: SYNC	0010
		11:8	syncsel_fifoOut(3:0)	Selects the syncing source(s) of the FIFO output side. A 1b in the bit enables the signal as a sync source. More than one sync source is permitted. Bit 11: sif_sync (via config31) Bit 10: OSTR – Dual Sync Sources Mode Bit 9: FRAME – Single Sync Source mode Bit 8: SYNC – Single Sync Source mode	0100
		7:1	Reserved	Reserved for factory use.	0000
		0	clkdiv_sync_sel	Selects the signal source for clock divider synchronization.	0
			<b>clkdiv_sync_sel</b>	<b>Sync Source</b>	
			0	OSTR	
			1	FRAME or SYNC, based on syncsel_fifoIn source selection (config32, bit<15:12>)	

**Table 45. Register Name: config33 – Address: 0x21, Default: 0x0000**

Register Name	Address	Bit	Name	Function	Default Value
config33	0x21	15:0	Reserved	Reserved for factory use.	0x0000

**Table 46. Register Name: config34 – Address: 0x22, Default: 0x1B1B**

Register Name	Address	Bit	Name	Function	Default Value
config34	0x22	15:14	pathA_in_sel(1:0)	Selects the word used for the A channel path.	00
		13:12	pathB_in_sel(1:0)	Selects the word used for the B channel path.	01
		11:10	pathC_in_sel(1:0)	Selects the word used for the C channel path.	10
		9:8	pathD_in_sel(1:0)	Selects the word used for the D channel path.	11
		7:6	DACA_out_sel(1:0)	Selects the word used for the DACA output.	00
		5:4	DACB_out_sel(1:0)	Selects the word used for the DACB output.	01
		3:2	DACC_out_sel(1:0)	Selects the word used for the DACC output.	10
		1:0	DACD_out_sel(1:0)	Selects the word used for the DACD output.	11

**Table 47. Register Name: config35 – Address: 0x23, Default: 0xFFFF**

Register Name	Address	Bit	Name	Function	Default Value	
config35	0x23	15:0	sleep_cntl(15:0)	Controls the routing of the CMOS SLEEP signal (pin B40 for the DAC3484IRKD and pin B8 for the DAC3484IZAY) to different blocks. When a bit in this register is set, the SLEEP signal will be sent to the corresponding block. The block will only be disabled when the SLEEP is logic HIGH and the correspond bit is set to 1b. These bits do not override SIF bits in config26 that control the same sleep function.	0xFFFF	
				<b>sleep_cntl(bit)</b>		<b>Function</b>
				15		DACA sleep
				14		DACB sleep
				13		DACC sleep
				12		DACD sleep
				11		Clock receiver sleep
				10		PLL sleep
				9		LVDS data sleep
				8		LVDS control sleep
				7		Temp sensor sleep
				6		reserved
				5		Bias amplifier sleep
All others	not used					

**Table 48. Register Name: config36 – Address: 0x24, Default: 0x0000**

Register Name	Address	Bit	Name	Function	Default Value
config36	0x24	15:13	datadly(2:0)	Controls the delay of the data inputs through the LVDS receivers. Each LSB adds approximately 50 ps. Refer to Digital Input Timing Specifications Table for details. 0: Minimum	000
		12:10	ckdly(2:0)	Controls the delay of the data clock through the LVDS receivers. Each LSB adds approximately 50 ps. Refer to Digital Input Timing Specifications Table for details. 0: Minimum	000
		9:0	Reserved	Reserved for factory use.	0x000

**Table 49. Register Name: config37 – Address: 0x25, Default: 0x7A7A**

Register Name	Address	Bit	Name	Function	Default Value
config37	0x25	15:0	iotest_pattern0	Dataword0 in the IO test pattern. It is used with the seven other words to test the input data. At the start of the IO test pattern, this word should be aligned with rising edge of FRAME or SYNC signal to indicate sample 0.	0x7A7A

**Table 50. Register Name: config38 – Address: 0x26, Default: 0xB6B6**

Register Name	Address	Bit	Name	Function	Default Value
config38	0x26	15:0	iotest_pattern1	Dataword1 in the IO test pattern. It is used with the seven other words to test the input data.	0xB6B6

**Table 51. Register Name: config39 – Address: 0x27, Default: 0xEAEA**

Register Name	Address	Bit	Name	Function	Default Value
config39	0x27	15:0	iotest_pattern2	Dataword2 in the IO test pattern. It is used with the seven other words to test the input data.	0xEAEA

**Table 52. Register Name: config40 – Address: 0x28, Default: 0x4545**

Register Name	Address	Bit	Name	Function	Default Value
config40	0x28	15:0	iotest_pattern3	Dataword3 in the IO test pattern. It is used with the seven other words to test the input data.	0x4545

**Table 53. Register Name: config41 – Address: 0x29, Default: 0x1A1A**

Register Name	Address	Bit	Name	Function	Default Value
config41	0x29	15:0	iotest_pattern4	Dataword4 in the IO test pattern. It is used with the seven other words to test the input data.	0x1A1A

**Table 54. Register Name: config42 – Address: 0x2A, Default: 0x1616**

Register Name	Address	Bit	Name	Function	Default Value
config42	0x2A	15:0	iotest_pattern5	Dataword5 in the IO test pattern. It is used with the seven other words to test the input data.	0x1616

**Table 55. Register Name: config43 – Address: 0x2B, Default: 0xAAAA**

Register Name	Address	Bit	Name	Function	Default Value
config43	0x2B	15:0	iotest_pattern6	Dataword6 in the IO test pattern. It is used with the seven other words to test the input data.	0xAAAA

**Table 56. Register Name: config44 – Address: 0x2C, Default: 0xC6C6**

Register Name	Address	Bit	Name	Function	Default Value
config44	0x2C	15:0	iotest_pattern7	Dataword7 in the IO test pattern. It is used with the seven other words to test the input data.	0xC6C6

**Table 57. Register Name: config45 – Address: 0x2D, Default: 0x0004**

Register Name	Address	Bit	Name	Function	Default Value
config45	0x2D	15	reserved	Reserved for factory use	0
		14	ostrtodig_sel	When set, the OSTR signal is passed directly to the digital block. This is the signal that is used to clock the dividers.	0
		13	ramp_ena	When set, a ramp signal is inserted in the input data at the FIFO input.	0
		12:1	Reserved	Reserved for factory use.	0000 0000 0010
		0	sifdac_ena	When set, the DAC output is set to the value in sifdac(15:0) in register <i>config48</i> . In this mode, sif_txena in config3 and TXENABLE inputs are ignored.	0

**Table 58. Register Name: config46 – Address: 0x2E, Default: 0x0000**

Register Name	Address	Bit	Name	Function	Default Value
config46	0x2E	15:8	grp_delayA(7:0)	Sets the group delay function for DACA. The maximum delay ranges from 30 ps to 100 ps and is dependent on DAC sample clock. Contact TI for specific application information.	0x00
		7:0	grp_delayB(7:0)	Sets the group delay function for DACB. The maximum delay ranges from 30 ps to 100 ps and is dependent on DAC sample clock. Contact TI for specific application information.	0x00

**Table 59. Register Name: config47 – Address: 0x2F, Default: 0x0000**

Register Name	Address	Bit	Name	Function	Default Value
config47	0x2F	15:8	grp_delayC(7:0)	Sets the group delay function for DACC. The maximum delay ranges from 30 ps to 100 ps and is dependent on DAC sample clock. Contact TI for specific application information.	0x00
		7:0	grp_delayD(7:0)	Sets the group delay function for DACD. The maximum delay ranges from 30 ps to 100 ps and is dependent on DAC sample clock. Contact TI for specific application information.	0x00

**Table 60. Register Name: config48 – Address: 0x30, Default: 0x0000**

Register Name	Address	Bit	Name	Function	Default Value
config48	0x30	15:0	sifdac(15:0)	Value sent to the DACs when <i>sifdac_ena</i> is asserted. DATACLK must be running to latch this value into the DACs. The format would be based on <i>twos</i> in register <i>config2</i> .	0x0000

**Table 61. Register Name: Version – Address: 0x7F, Default: 0x540C (Read Only)**

Register Name	Address	Bit	Name	Function	Default Value
version	0x7F	15:10	Reserved	Reserved for factory use.	010101
		9	Reserved	Reserved for factory use.	0
		8:7	Reserved	Reserved for factory use.	00
		6:5	Reserved	Reserved for factory use.	00
		4:3	deviceid(1:0)	Returns 01b for DAC3484.	01
		2:0	versionid(2:0)	A hardwired register that contains the version of the chip.	100

## 8 Application and Implementation

---

### NOTE

Information in the following applications sections is not part of the TI component specification, and TI does not warrant its accuracy or completeness. TI's customers are responsible for determining suitability of components for their purposes. Customers should validate and test their design implementation to confirm system functionality.

---

### 8.1 Application Information

The DAC3484 is a quad 16-bit DAC with max input data rate of up to 312.5 MSPS per DAC and max DAC update rate of 1.25 GSPS after the final, selectable interpolation stages. With build-in interpolation filter of 2x, 4x, 8x, and 16x options, the lower input data rate can be interpolated all the way to 1.25 GSPS. This allows the DAC to update the samples at higher rate, and pushes the DAC images further away to relax anti-image filter specification due to the increased Nyquist bandwidth. With integrated coarse and fine mixers, baseband signal can be upconverted to an intermediate frequency (IF) signal between the baseband processor and post-DAC analog signal chains.

The DAC can output baseband or IF when connected to post-DAC analog signals chain components such as transformers or IF amplifiers. When used in conjunction with TI RF quadrature modulator such as the TRF3705, the DAC and RF modulator can function as a set of baseband or IF upconverter. With integrated QMC circuits, the LO offset and the sideband artifacts can be properly corrected in the direct up-conversion applications. The DAC3484 provides the bandwidth, performance, small footprint, and lower power consumption needed for multi-mode 2G/3G/4G cellular base stations to migrate to more advanced technologies, such as LTE-Advanced and carrier aggregation on multiple antennas.

## 8.2 Typical Applications

### 8.2.1 IF Based LTE Transmitter

Figure 91 shows an example block diagram for a direct conversion radio. The design requires a single carrier, 20-MHz LTE signal. The system has digital-predication (DPD) to correct up to 5th order distortion so the total DAC output bandwidth is 100 MHz. Interpolation is used to output the signal at highest sampling rate possible to simplify the analog filter requirements and move high order harmonics out of band (due to wider Nyquist zone). The internal PLL is used to generate the final DAC output clock from a reference clock of 491.52 MHz.

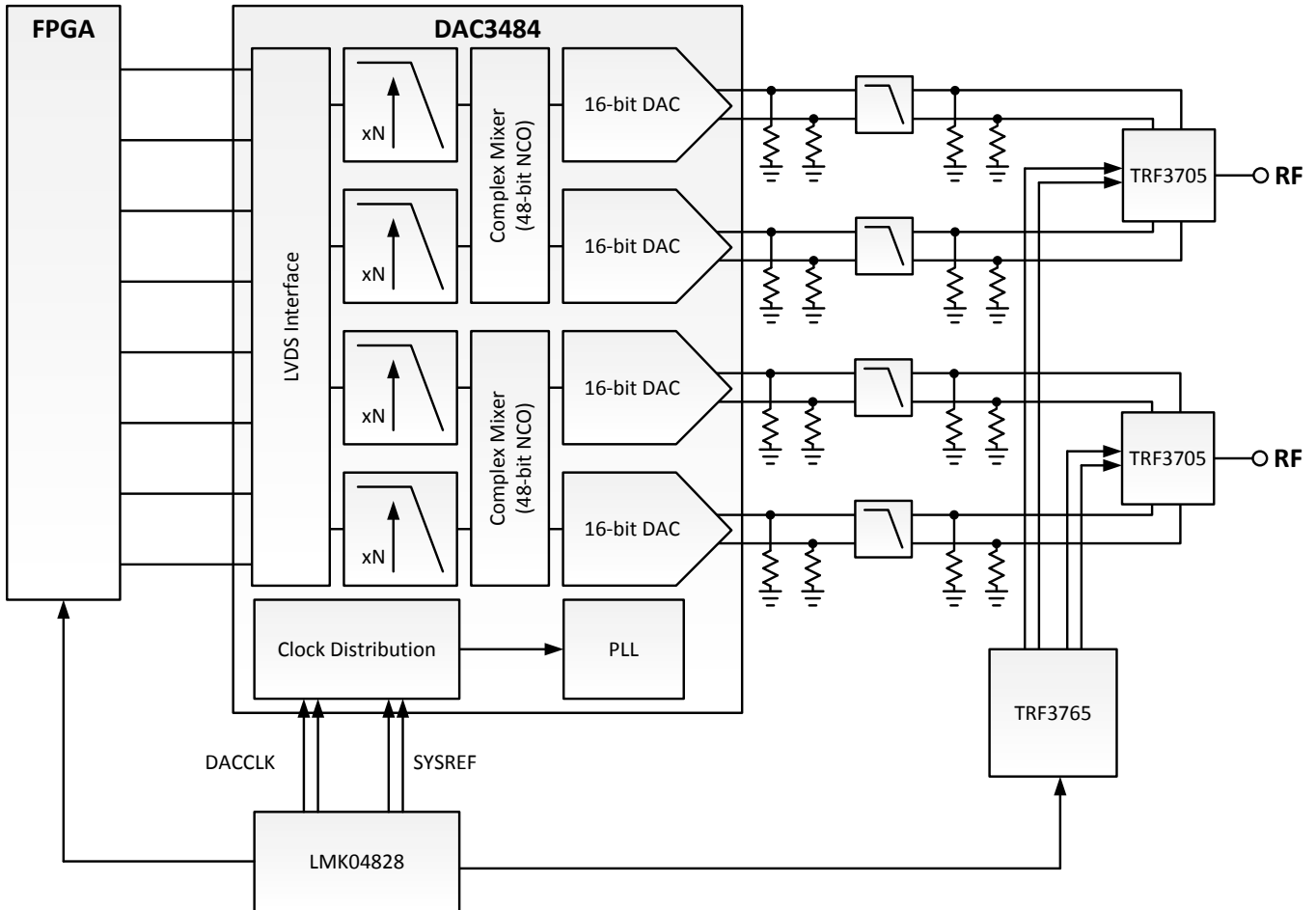

Figure 91. Dual Low-IF Wideband LTE Transmitter Diagram

#### 8.2.1.1 Design Requirements

For this design example, use the parameters listed in Table 62 as the input parameters.

Table 62. Design Parameters

DESIGN PARAMETER	EXAMPLE VALUE
Signal Bandwidth ( $BW_{\text{signal}}$ )	20 MHz
Total DAC Output Bandwidth ( $BW_{\text{total}}$ )	100 MHz
DAC PLL	On
DAC PLL Reference Frequency	491.52 MHz
Maximum FPGA LVDS Rate	491.52 Mbps

## 8.2.1.2 Detailed Design Procedure

### 8.2.1.2.1 Data Input Rate

Nyquist theory states that the data rate must be at least two times the highest signal frequency. The data will be sent to the DAC as complex baseband data. Due to the quadrature nature of the signal, each in-phase (I component) and quadrature (Q component) need to have 50 MHz of bandwidth to construct 100 MHz of complex bandwidth. Since the interpolation filter design is not the ideal half-band filter design with infinite roll-off at  $F_{DATA}/2$  (refer to FIR Filters section for more detail), the filter limits the useable input bandwidth to about 40 percent of  $F_{DATA}$ . Therefore, the minimum data input rate is 125 MSPS. Since the standard telecom data rate is typically multiples of 30.72 MSPS, the DAC input data rate is chosen to be eight times of 30.72 MSPS, which is 245.76 MSPS.

### 8.2.1.2.2 Interpolation

It is desired to use the highest DAC output rate as possible to move the DAC images further from the signal of interest to ease analog filter requirement. The DAC output rate must be greater than two times the highest output frequency of 200 MHz, which is greater than 400 MHz. [Table 63](#) shows the possible DAC output rates based on the data input rate and available interpolation settings. The DAC image frequency is also listed.

**Table 63. Interpolation**

$F_{DATA}$	INTERPOLATION	$F_{DAC}$	POSSIBLE?	LOWEST IMAGE FREQUENCY	DISTANCE FROM BAND OF INTEREST
245.76 MSPS	1	245.76 MSPS	No	N/A	N/A
245.76 MSPS	2	491.52 MSPS	Yes	318.64 MHz	145.76 MHz
245.76 MSPS	4	983.04 MSPS	Yes	810.16 MHz	637.28 MHz
245.76 MSPS	8	1966.08 MSPS	No	N/A	N/A
245.76 MSPS	16	3932.16 MSPS	No	N/A	N/A

### 8.2.1.2.3 LO Feedthrough and Sideband Correction

For typical IF based systems, the IF location is selected such that the image location and the LO feedthrough location is far from the signal location. The minimum distance is based on the bandpass filter roll-off and attenuation level at the LO feedthrough and image location. If sufficient attenuation level of these two artifacts meets the system requirement, then further digital cancellation of these artifacts may not be needed.

Although the I/Q modulation process will inherently reduce the level of the RF sideband signal, an IF based transmitter without sufficient RF image rejection capabilities or an zero-IF based system (detail in the next section) will likely need additional sideband suppression to maximize performance. Further, any mixing process will result in some feedthrough of the LO source. The DAC3484 has build-in digital features to cancel both the LO feedthrough and sideband signal. The LO feedthrough is corrected by adding a DC offset to the DAC outputs until the LO feedthrough power is suppressed. The sideband suppression can be improved by correcting the gain and phase differences between the I and Q analog outputs through the digital QMC block. Besides gain and phase differences between the I and Q analog outputs, group delay differences may also be present in the signal path and are typically contributed by group delay variations of post DAC image reject analog filters and PCB trace variations. Since delay in time translates to higher order linear phase variation, the sideband of a wideband system may not be completely suppressed by typical digital QMC block. The DAC3484 has integrated group delay correction feature to provide delay adjustments. (The maximum group delay correction ranges from 30 ps to 100 ps and is dependent on DAC sample clock. Contact TI for specific application information.) Moreover, system designer may implement additional linear group delay compensation in the host processor to the DAC to perform higher order sideband suppression.

### 8.2.1.3 Application Curves

The ACPR performance for LTE 20 MHz TM1.1 are shown in Figure 92, Figure 93, Figure 93, and Figure 93. The figures provide comparisons between two major LTE bands such as 2.14 GHz and 2.655 GHz, and also comparisons between two different DAC clocking options such as DAC on-chip PLL mode and external clocking mode.

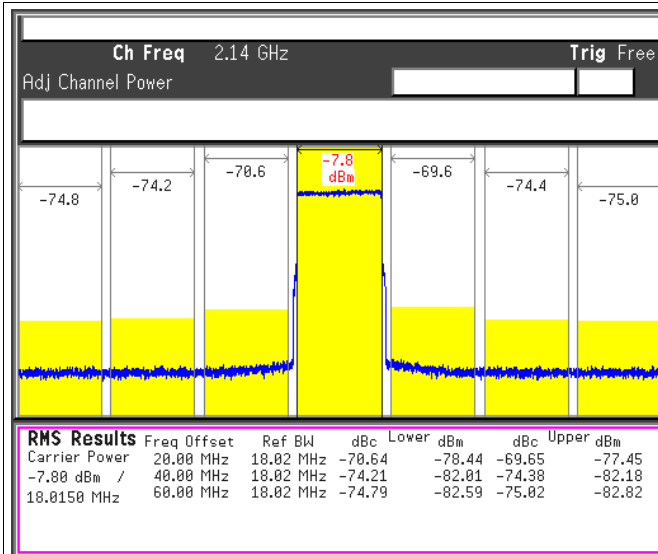

DAC Output IF = 122.88 MHz, LO = 2017.12 MHz, DAC Clock = External Clock Source from LMK04806

Figure 92. 20MHz TM1.1 LTE Carrier at 2.14GHz

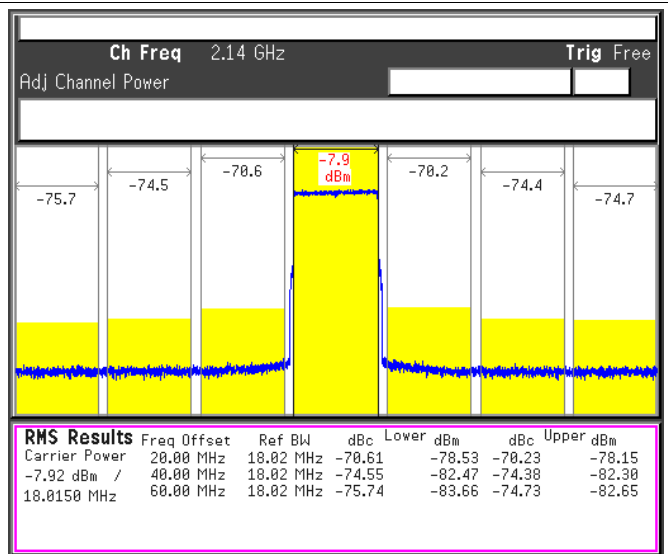

DAC Output IF = 122.88 MHz, LO = 2017.12 MHz, DAC Clock = DAC3484 On-Chip PLL

Figure 93. 20MHz TM1.1 LTE Carrier at 2.14GHz

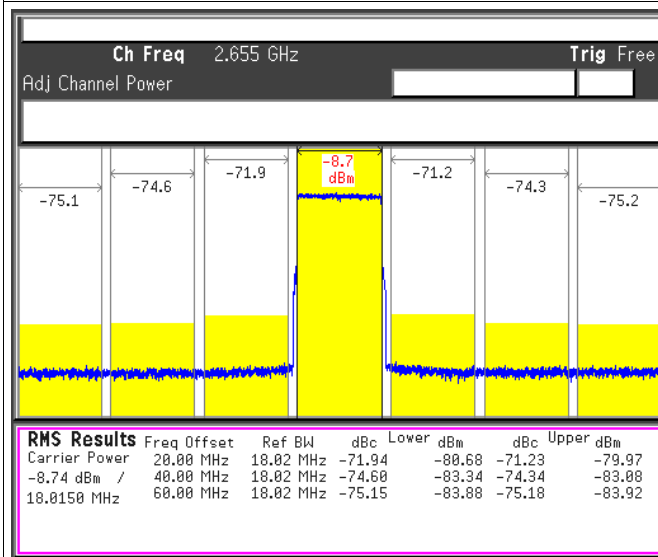

DAC Output IF = 122.88 MHz, LO = 2532.12 MHz, DAC Clock = External Clock Source from LMK04806

Figure 94. 20MHz TM1.1 LTE Carrier at 2.655GHz

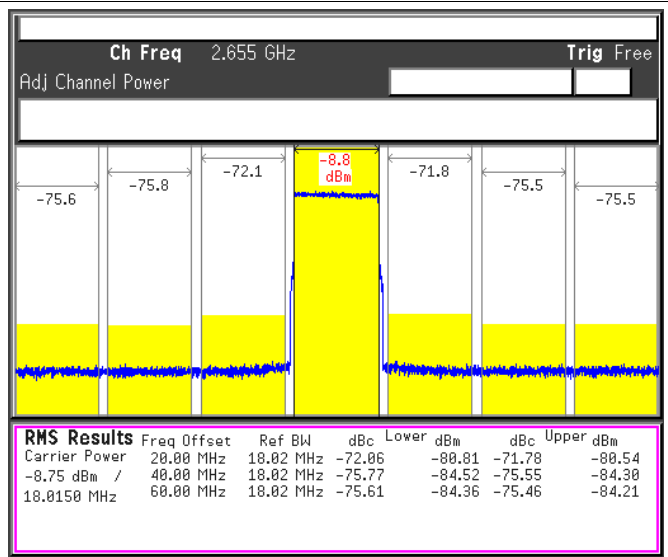

DAC Output IF = 122.88 MHz, LO = 2532.12 MHz, DAC Clock = DAC3484 On-Chip PLL

Figure 95. 20MHz TM1.1 LTE Carrier at 2.655GHz

### 8.2.2 Direct Upconversion (Zero IF) LTE Transmitter

Figure 91 shows an example block diagram for a direct conversion radio. The design specification requires that the desired output bandwidth is 40 MHz, which could be, for instance, a typical LTE signal. The system has DPD to correct up to 5th order distortion so the total DAC output bandwidth is 200 MHz. Interpolation is used to output the signal at the highest sampling rate possible to simplify the analog filtering requirements and move high order harmonics out of band (due to wider Nyquist zone). The DAC sampling clock is provided by high quality clock synthesizer such as the LMK0480x family.

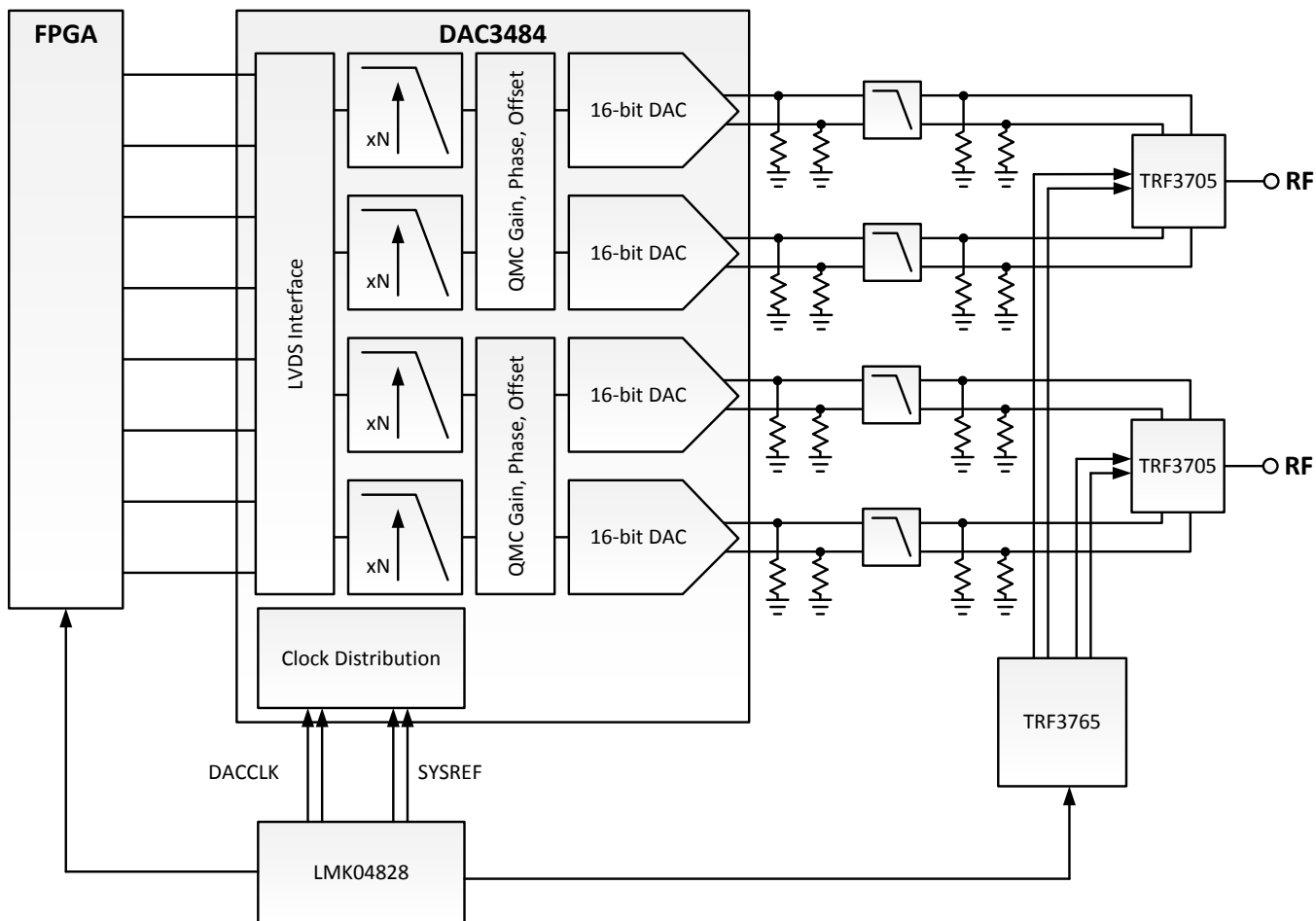

Figure 96. Zero LTE Transmitter Diagram

#### 8.2.2.1 Design Requirements

For this design example, use the parameters listed in Table 64 as the input parameters.

Table 64. Design Parameters

DESIGN PARAMETER	EXAMPLE VALUE
Signal Bandwidth ( $BW_{\text{signal}}$ )	40 MHz
Total DAC Output Bandwidth ( $BW_{\text{total}}$ )	200 MHz
DAC PLL	Off
Maximum FPGA LVDS Rate	1228.8 Mbps

### 8.2.2.2 Detailed Design Procedure

#### 8.2.2.2.1 Data Input Rate

Nyquist theory states that the data rate must be at least two times the highest signal frequency. The data will be sent to the DAC as complex baseband data. Due to the quadrature nature of the signal, each in-phase (I component) and quadrature (Q component) need to have 100 MHz of bandwidth to construct 200 MHz of complex bandwidth. Since the interpolation filter design is not the ideal half-band filter design with infinite roll-off at  $F_{DATA}/2$  (refer to [FIR Filters](#) section for more detail), the filter limits the useable input bandwidth to about 44 percent of  $F_{DATA}$  with less than 0.1dB of FIR filter roll-off. Therefore, the minimum data input rate is 228 MSPS. Since the standard telecom data rate is typically multiples of 30.72 MSPS, the DAC input data rate is chosen to be 10 times of 30.72 MSPS, which is 307.2 MSPS.

#### 8.2.2.2.2 Interpolation

It is desired to use the highest DAC output rate as possible to move the DAC images further from the signal of interest to ease analog filter requirement. The DAC output rate must be greater than two times the highest output frequency of 100 MHz, which is greater than 200 MHz. The table below shows the possible DAC output rates based on the data input rate and available interpolation settings. The DAC image frequency is also listed.

**Table 65. Interpolation**

$F_{DATA}$	INTERPOLATION	$F_{DAC}$	POSSIBLE?	LOWEST IMAGE FREQUENCY	DISTANCE FROM BAND OF INTEREST
307.2 MSPS	1	307.2 MSPS	Yes	287.2 MHz	267.2 MHz
307.2 MSPS	2	614.4 MSPS	Yes	594.4 MHz	574.4 MHz
307.2 MSPS	4	1228.8 MSPS	Yes	1208.8	1188.8
307.2 MSPS	8	2457.6 MSPS	No	N/A	N/A
307.2 MSPS	16	4915.2 MSPS	No	N/A	N/A

#### 8.2.2.2.3 LO Feedthrough and Sideband Correction

Refer to [LO Feedthrough and Sideband Correction](#) section of IF based LTE Transmitter design.

**8.2.2.3 Application Curves**

The ACPR performance for LTE 20MHz TM1.1 are shown in [Figure 97](#) and [Figure 98](#). The figures provide comparisons between two major LTE bands such as 2.14 GHz and 2.655 GHz with DAC clocking option set to external clocking mode.

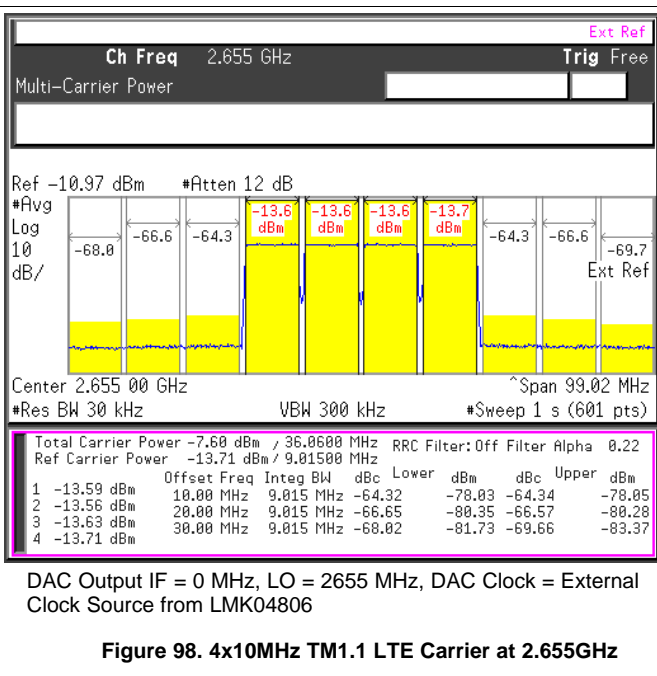
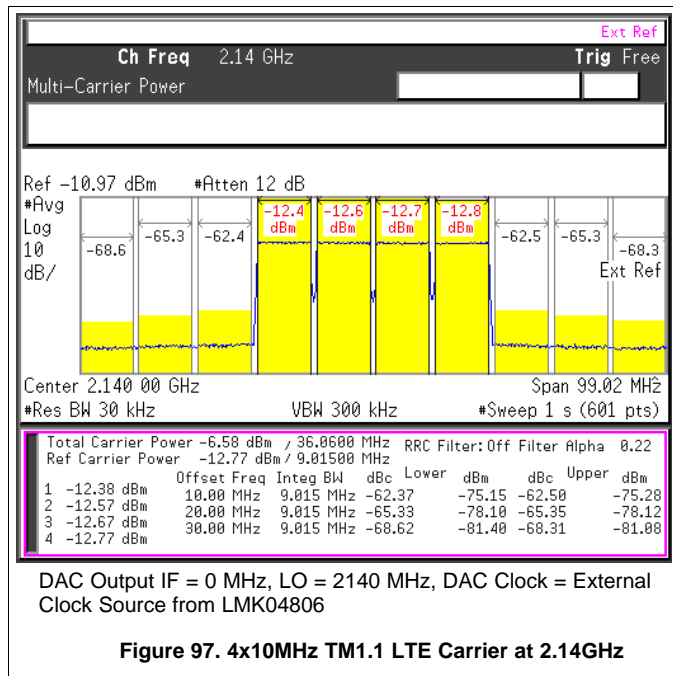

## 9 Power Supply Recommendations

As shown in Figure 99, the DAC3484 device has various power rails and has two primary voltages of 1.2 V and 3.3 V. Some of the DAC power rails such as CLKVDD and AVDD are more noise sensitive than other rails because they are mainly powering the switch drivers for the current switch array and the current bias circuits, respectively. These circuits are the main analog DAC core. Any power supply noises such as switching power supply ripple may be modulated directly onto the signal of interest. These two power rails should be powered by low noise power supplies such as LDO. Powering the rail directly with switching power supplies is not recommended for these two rails.

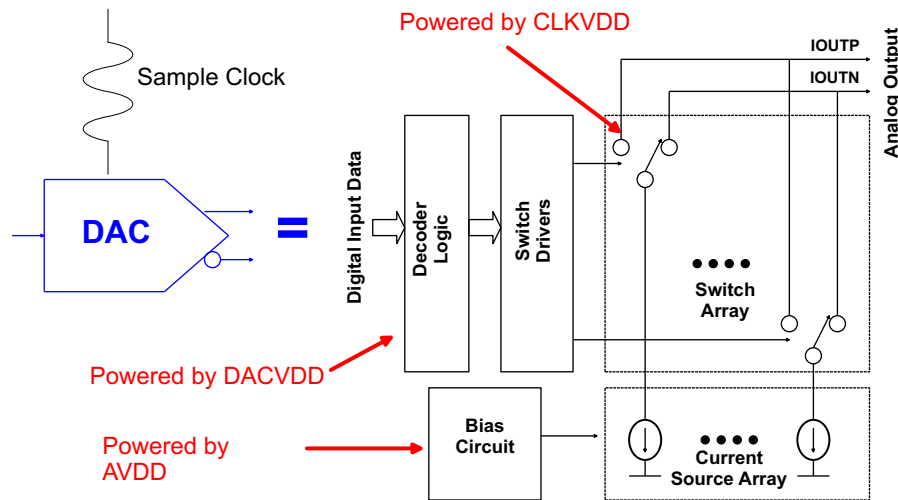

Figure 99. Interpolation Filters, NCOs, and QMC Blocks Powered by DIGVDD

With the DAC3484 being a mixed signal device, the device contains circuits that bridges the digital section and the analog section. The DACVDD powers these sections. System designer can design this rail in secondary priority. Powering the rail with LDO is recommended. Unless system designer pays special care to supply filtering and power supply routing/placement, powering the rail directly with switching power supplies is not recommended for this rail.

Since digital circuits have more inherent noise immunity than analog circuits, the power supply noise requirements for DIGVDD of the digital section of the device may be relaxed and placed at a lower priority. Depending on the spur level requirement, routing and placement of the power supply, power the rail directly with switching power supplies can be possible. With the digital logics running, the DIGVDD rail may draw significant current. If the power supply traces and filtering network have significant DC resistance loss (for example, DCR), then the final supply voltage seen by the DIGVDD rail may not be sufficient to meet the minimum power supply level. For instance, with 450 mA of DIGVDD current and about 0.1 Ω of DCR from the ferrite bead, the final supply voltage at the DIGVDD pins may be 1.2 V – 0.045 V = 1.155 V. This is fairly close to the minimum supply voltage range of 1.14 V. System designer may need to elevate the power supply voltage according to the DCR level or design a feedback network for the power supply to account for associated voltage drop. To ensure power supply accuracy and to account for power supply filter network loss at operating conditions, the use of the ATEST function in register config27 to check the internal power supply nodes is recommended.

The table below is a summary of the various power supply nodes of the DAC. Care should be taken to keep clean power supplies routing away from noisy digital supplies. It is recommended to use at least two power layers. Power supplies for digital circuits tend to have more switching activities and are typically noisier, and system designer should avoid sharing the digital power rail (for example, power supplies for FPGA or DIGVDD of DAC3484) with the analog power rail (for example, CLKVDD and AVDD of DAC3484). Avoid placing noisy supplies and clean supplies on adjacent board layers and use a ground layer between these two supplies if possible. All supply pins should be decoupled as close to the pins as possible by using small value capacitors, with larger bulk capacitors placed further away and near the power supply source.

**Table 66. Power Rails**

POWER RAILS	TYPICAL VOLTAGE	NOISE SENSITIVITY	RECOMMENDATIONS	POWER SUPPLY DESIGN PRIORITY
CLKVDD	1.2 V	High	Provide clean supply to the rail. Avoid spurious noise or coupling from other supplies	High
AVDD	3.3 V	High	Provide clean supply to the rail. Avoid spurious noise or coupling from other supplies	High
DACVDD	1.2 V	Medium	Provide clean supply to the rail. Avoid spurious noise or coupling from other supplies	Medium
DIGVDD	1.2 V	Low	Keep Away from other noise sensitive nodes in placement and routing.	Low

## 10 Layout

### 10.1 Layout Guidelines

The design of the PCB is critical to achieve the full performance of the DAC3484 device. Defining the PCB stackup should be the first step in the board design. Experience has shown that at least six layers are required to adequately route all required signals to and from the device. Each signal routing layer must have an adjacent solid ground plane to control signal return paths to have minimal loop areas and to achieve controlled impedances for microstrip and stripline routing. Power planes must also have adjacent solid ground planes to control supply return paths. Minimizing the space between supply and ground planes improves performance by increasing the distributed decoupling.

Although the DAC3484 device consists of both analog and digital circuitry, TI highly recommends solid ground planes that encompass the device and its input and output signal paths. TI does not recommend split ground planes that divide the analog and digital portions of the device. Split ground planes may improve performance if a nearby, noisy, digital device is corrupting the ground reference of the analog signal path. When split ground planes are employed, one must carefully control the supply return paths and keep the paths on top of their respective ground reference planes.

Quality analog output signals and input conversion clock signal path layout is required for full dynamic performance. Symmetry of the differential signal paths and discrete components in the path is mandatory, and symmetrical shunt-oriented components should have a common grounding via. The high frequency requirements of the analog output and clock signal paths necessitate using differential routing with controlled impedances and minimizing signal path stubs (including vias) when possible.

Coupling onto or between the clock and output signals paths should be avoided using any isolation techniques available including distance isolation, orientation planning to prevent field coupling of components like inductors and transformers, and providing well coupled reference planes. Via stitching around the clock signal path and the input analog signal path provides a quiet ground reference for the critical signal paths and reduces noise coupling onto these paths. Sensitive signal traces must not cross other signal traces or power routing on adjacent PCB layers, rather a ground plane must separate the traces. If necessary, the traces should cross at 90° angles to minimize crosstalk.

The substrate (dielectric) material requirements of the PCB are largely influenced by the speed and length of the high speed serial lanes. Affordable and common FR4 varieties are adequate in most cases.

Coupling of ambient signals into the signal path is reduced by providing quiet, close reference planes and by maintaining signal path symmetry to ensure the coupled noise is common-mode. Faraday caging may be used in very noise environment and high dynamic range applications to isolate the signal path.

The following layout guidelines correspond to the layout shown in [Figure 100](#).

1. DAC output termination resistors should be placed as close to the output pins as possible to provide a DC path to ground and set the source impedance matching.
2. For DAC on-chip PLL clocking mode, if the external loop filter is not used, leave the loop filter pin floating without any board routing nearby. Signals coupling to this node may cause clock mixing spurs in the DAC output.
3. Route the high speed LVDS lanes as impedance-controlled, tightly-coupled, differential traces.

## Layout Guidelines (continued)

4. Maintain a solid ground plane under the LVDS lanes without any ground plane splits.
5. Simulation of the LVDS channel with DAC3484 IBIS model is recommended to verify good eye opening of the data patterns.
6. Keep the OSTR signal routing away from the DACCLK routing to reduce coupling.
7. Keep routing for RBIAS short, for instance a resistor can be placed on the board directly connecting the RBIAS pin to the ground layer.

The following layout guidelines correspond to the layouts shown in [Figure 101](#) and [Figure 102](#).

1. Noise power supplies should be routed away from clean supplies. Use two power plane layers, preferably with a ground layer in between.
2. As shown in [Figure 101](#) and [Figure 102](#), both layers three and four are designated for power supply planes. The DAC analog powers are all in the same layer to avoid coupling with each other, and the planes are copied from layer three to layer four for double the copper coverage area.
3. Decoupling capacitors should be placed as close to the supply pins as possible. For instance, a capacitor can be placed on the bottom of the board directly connecting the supply pin to a ground layer.

### 10.1.1 Assembly

Information regarding the package and assembly of the WQFN-MR package version of the DAC3484 can be found at the end of the data sheet and also on the following application note: [SZZA059](#)

Information regarding the package and assembly of the ZAY package version of the DAC3484 can be found at the end of the data sheet and also on the following application note: [SPRAA99](#)

## 10.2 Layout Examples

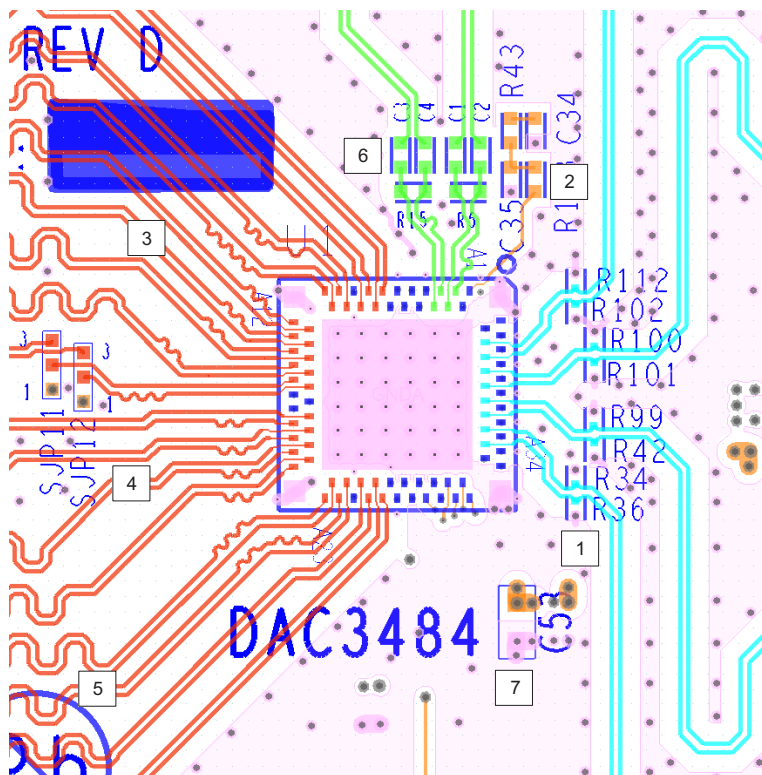

**Figure 100. Top Layer of DAC3484 Layout Showing High Speed Signals such as LVDS Bus, DACCLK, OSTR, and DAC Outputs. Layout Example from TSW3085EVM Rev D**

Layout Examples (continued)

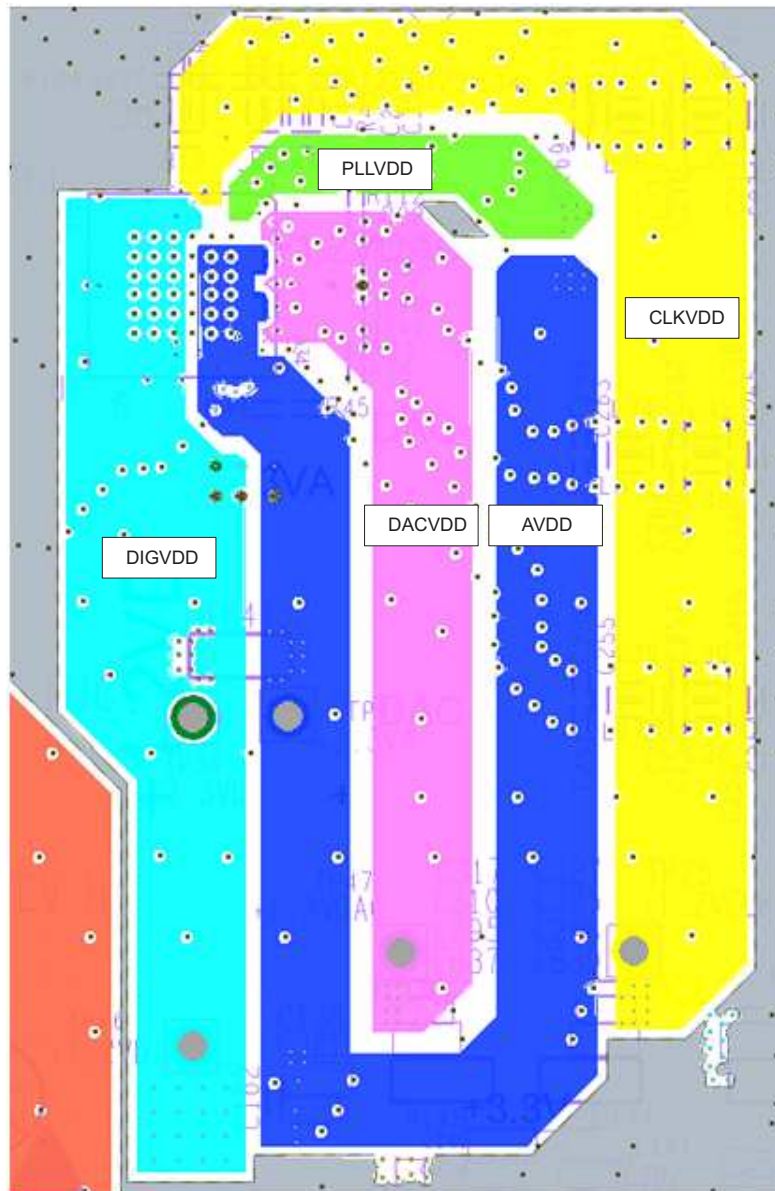
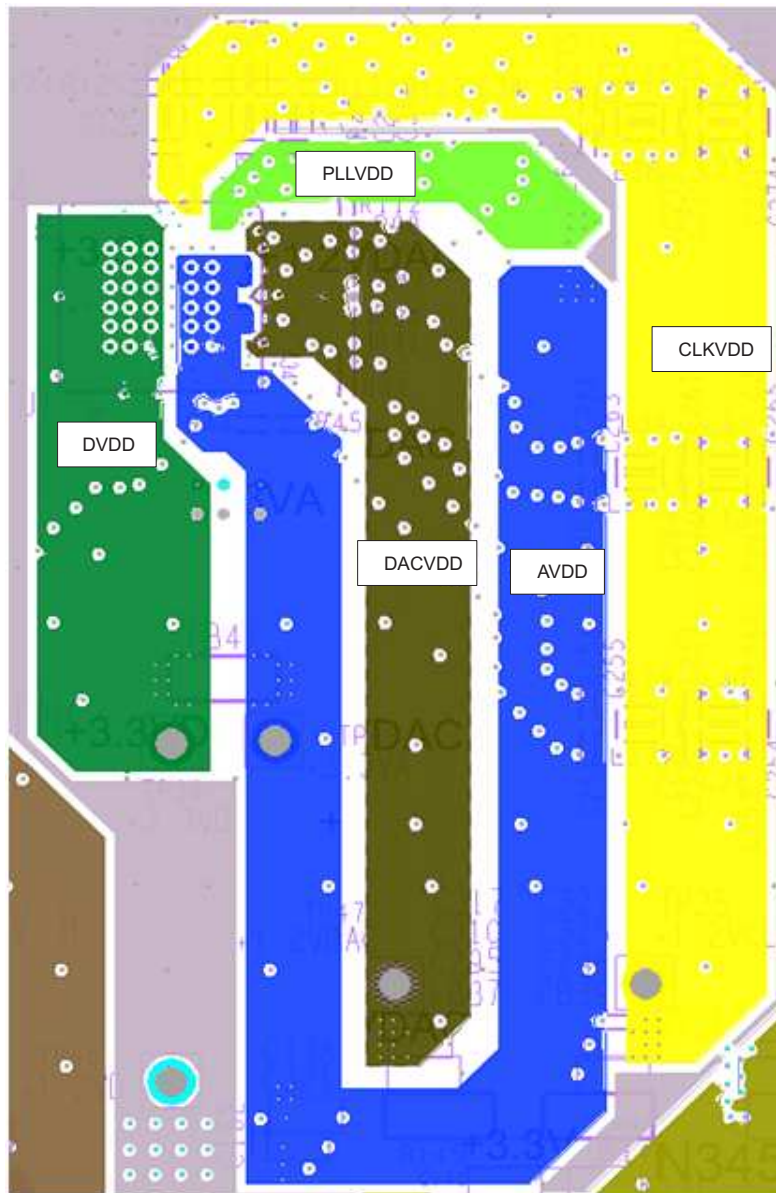

Figure 101. Third Layer of DAC3484 Layout Showing Power Layers. Layout Example from DAC3484EVM Rev H

**Layout Examples (continued)**



**Figure 102. Fourth Layer of DAC3484 Layout Showing Power Layers. Layout Example from DAC3484EVM Rev H**

## 11 Device and Documentation Support

### 11.1 Device Support

#### 11.1.1 Third-Party Products Disclaimer

TI'S PUBLICATION OF INFORMATION REGARDING THIRD-PARTY PRODUCTS OR SERVICES DOES NOT CONSTITUTE AN ENDORSEMENT REGARDING THE SUITABILITY OF SUCH PRODUCTS OR SERVICES OR A WARRANTY, REPRESENTATION OR ENDORSEMENT OF SUCH PRODUCTS OR SERVICES, EITHER ALONE OR IN COMBINATION WITH ANY TI PRODUCT OR SERVICE.

#### 11.1.2 Device Nomenclature

##### 11.1.2.1 Definition of Specifications

**Adjacent Carrier Leakage Ratio (ACLR):** Defined for a 3.84Mcps 3GPP W-CDMA input signal measured in a 3.84-MHz bandwidth at a 5-MHz offset from the carrier with a 12dB peak-to-average ratio.

**Analog and Digital Power Supply Rejection Ratio (APSSR, DPSSR):** Defined as the percentage error in the ratio of the delta IOUT and delta supply voltage normalized with respect to the ideal IOUT current.

**Differential Nonlinearity (DNL):** Defined as the variation in analog output associated with an ideal 1 LSB change in the digital input code.

**Gain Drift:** Defined as the maximum change in gain, in terms of ppm of full-scale range (FSR) per °C, from the value at ambient (25°C) to values over the full operating temperature range.

**Gain Error:** Defined as the percentage error (in FSR%) for the ratio between the measured full-scale output current and the ideal full-scale output current.

**Integral Nonlinearity (INL):** Defined as the maximum deviation of the actual analog output from the ideal output, determined by a straight line drawn from zero scale to full scale.

**Intermodulation Distortion (IMD3):** The two-tone IMD3 is defined as the ratio (in dBc) of the 3rd-order intermodulation distortion product to either fundamental output tone.

**Offset Drift:** Defined as the maximum change in DC offset, in terms of ppm of full-scale range (FSR) per °C, from the value at ambient (25°C) to values over the full operating temperature range.

**Offset Error:** Defined as the percentage error (in FSR%) for the ratio between the measured mid-scale output current and the ideal mid-scale output current.

**Output Compliance Range:** Defined as the minimum and maximum allowable voltage at the output of the current-output DAC. Exceeding this limit may result reduced reliability of the device or adversely affecting distortion performance.

**Reference Voltage Drift:** Defined as the maximum change of the reference voltage in ppm per degree Celsius from value at ambient (25°C) to values over the full operating temperature range.

**Spurious Free Dynamic Range (SFDR):** Defined as the difference (in dBc) between the peak amplitude of the output signal and the peak spurious signal within the first Nyquist zone.

**Noise Spectral Density (NSD):** Defined as the difference of power (in dBc) between the output tone signal power and the noise floor of 1-Hz bandwidth within the first Nyquist zone.

## 11.2 Documentation Support

### 11.2.1 Related Documentation

- *Design Summary Multi-row Quad Flat No-lead (MRQFN) Application Report (SZZA059)*
- *nFBGA Packaging Application Report (SPRAA99)*
- *DAC348x Device Configuration and Synchronization Application Report (SLAA584)*
- *Semiconductor and IC Package Thermal Metrics Application Report (SPRA953)*
- *Using DAC348x with Fault Detection and Auto Output Shut-off Feature Application Report (SLAA585)*

## 11.3 Community Resources

The following links connect to TI community resources. Linked contents are provided "AS IS" by the respective contributors. They do not constitute TI specifications and do not necessarily reflect TI's views; see TI's [Terms of Use](#).

**TI E2E™ Online Community** *TI's Engineer-to-Engineer (E2E) Community*. Created to foster collaboration among engineers. At [e2e.ti.com](http://e2e.ti.com), you can ask questions, share knowledge, explore ideas and help solve problems with fellow engineers.

**Design Support** *TI's Design Support* Quickly find helpful E2E forums along with design support tools and contact information for technical support.

## 11.4 Trademarks

E2E is a trademark of Texas Instruments.  
All other trademarks are the property of their respective owners.

## 11.5 Electrostatic Discharge Caution



These devices have limited built-in ESD protection. The leads should be shorted together or the device placed in conductive foam during storage or handling to prevent electrostatic damage to the MOS gates.

## 11.6 Glossary

[SLYZ022](#) — *TI Glossary*.

This glossary lists and explains terms, acronyms, and definitions.

## 12 Mechanical, Packaging, and Orderable Information

The following pages include mechanical, packaging, and orderable information. This information is the most current data available for the designated devices. This data is subject to change without notice and revision of this document. For browser-based versions of this data sheet, refer to the left-hand navigation.

**PACKAGING INFORMATION**

Orderable Device	Status (1)	Package Type	Package Drawing	Pins	Package Qty	Eco Plan (2)	Lead/Ball Finish (6)	MSL Peak Temp (3)	Op Temp (°C)	Device Marking (4/5)	Samples
DAC3484IRKDR	ACTIVE	WQFN-MR	RKD	88	2000	Green (RoHS & no Sb/Br)	CU NIPDAU	Level-3-260C-168 HR	-40 to 85	DAC3484I	<a href="#">Samples</a>
DAC3484IRKDT	ACTIVE	WQFN-MR	RKD	88	250	Green (RoHS & no Sb/Br)	CU NIPDAU	Level-3-260C-168 HR	-40 to 85	DAC3484I	<a href="#">Samples</a>
DAC3484IZAY	ACTIVE	NFBGA	ZAY	196	160	Green (RoHS & no Sb/Br)	SNAGCU	Level-3-260C-168 HR	-40 to 85	DAC3484I	<a href="#">Samples</a>
DAC3484IZAYR	ACTIVE	NFBGA	ZAY	196	1000	Green (RoHS & no Sb/Br)	SNAGCU	Level-3-260C-168 HR	-40 to 85	DAC3484I	<a href="#">Samples</a>

(1) The marketing status values are defined as follows:

**ACTIVE:** Product device recommended for new designs.

**LIFEBUY:** TI has announced that the device will be discontinued, and a lifetime-buy period is in effect.

**NRND:** Not recommended for new designs. Device is in production to support existing customers, but TI does not recommend using this part in a new design.

**PREVIEW:** Device has been announced but is not in production. Samples may or may not be available.

**OBSOLETE:** TI has discontinued the production of the device.

(2) Eco Plan - The planned eco-friendly classification: Pb-Free (RoHS), Pb-Free (RoHS Exempt), or Green (RoHS & no Sb/Br) - please check <http://www.ti.com/productcontent> for the latest availability information and additional product content details.

**TBD:** The Pb-Free/Green conversion plan has not been defined.

**Pb-Free (RoHS):** TI's terms "Lead-Free" or "Pb-Free" mean semiconductor products that are compatible with the current RoHS requirements for all 6 substances, including the requirement that lead not exceed 0.1% by weight in homogeneous materials. Where designed to be soldered at high temperatures, TI Pb-Free products are suitable for use in specified lead-free processes.

**Pb-Free (RoHS Exempt):** This component has a RoHS exemption for either 1) lead-based flip-chip solder bumps used between the die and package, or 2) lead-based die adhesive used between the die and leadframe. The component is otherwise considered Pb-Free (RoHS compatible) as defined above.

**Green (RoHS & no Sb/Br):** TI defines "Green" to mean Pb-Free (RoHS compatible), and free of Bromine (Br) and Antimony (Sb) based flame retardants (Br or Sb do not exceed 0.1% by weight in homogeneous material)

(3) MSL, Peak Temp. - The Moisture Sensitivity Level rating according to the JEDEC industry standard classifications, and peak solder temperature.

(4) There may be additional marking, which relates to the logo, the lot trace code information, or the environmental category on the device.

(5) Multiple Device Markings will be inside parentheses. Only one Device Marking contained in parentheses and separated by a "~" will appear on a device. If a line is indented then it is a continuation of the previous line and the two combined represent the entire Device Marking for that device.

(6) Lead/Ball Finish - Orderable Devices may have multiple material finish options. Finish options are separated by a vertical ruled line. Lead/Ball Finish values may wrap to two lines if the finish value exceeds the maximum column width.

**Important Information and Disclaimer:** The information provided on this page represents TI's knowledge and belief as of the date that it is provided. TI bases its knowledge and belief on information provided by third parties, and makes no representation or warranty as to the accuracy of such information. Efforts are underway to better integrate information from third parties. TI has taken and continues to take reasonable steps to provide representative and accurate information but may not have conducted destructive testing or chemical analysis on incoming materials and chemicals. TI and TI suppliers consider certain information to be proprietary, and thus CAS numbers and other limited information may not be available for release.

In no event shall TI's liability arising out of such information exceed the total purchase price of the TI part(s) at issue in this document sold by TI to Customer on an annual basis.

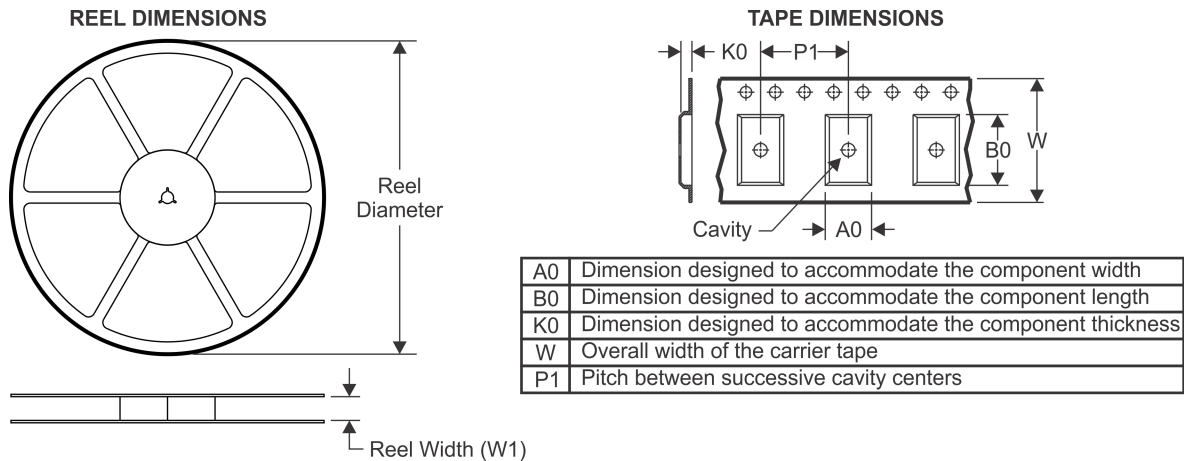
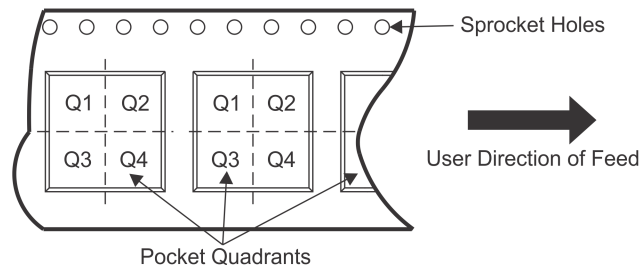
**TAPE AND REEL INFORMATION**

**QUADRANT ASSIGNMENTS FOR PIN 1 ORIENTATION IN TAPE**

\*All dimensions are nominal

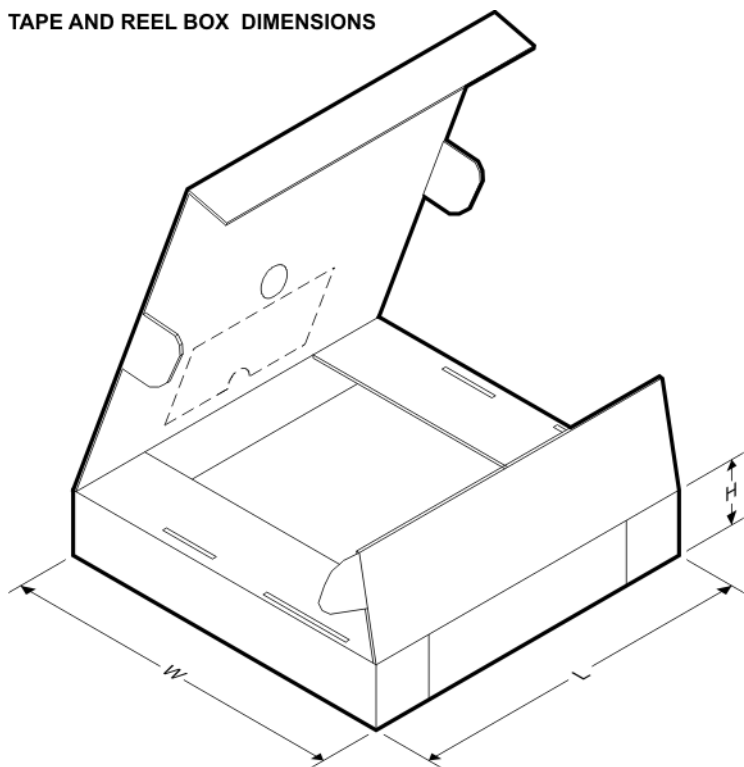
Device	Package Type	Package Drawing	Pins	SPQ	Reel Diameter (mm)	Reel Width W1 (mm)	A0 (mm)	B0 (mm)	K0 (mm)	P1 (mm)	W (mm)	Pin1 Quadrant
DAC3484IRKDR	WQFN-MR	RKD	88	2000	330.0	16.4	9.3	9.3	1.5	12.0	16.0	Q2
DAC3484IRKDT	WQFN-MR	RKD	88	250	330.0	16.4	9.3	9.3	1.5	12.0	16.0	Q2

**TAPE AND REEL BOX DIMENSIONS**

\*All dimensions are nominal

Device	Package Type	Package Drawing	Pins	SPQ	Length (mm)	Width (mm)	Height (mm)
DAC3484IRKDR	WQFN-MR	RKD	88	2000	336.6	336.6	28.6
DAC3484IRKDT	WQFN-MR	RKD	88	250	336.6	336.6	28.6

# ZAY0196A

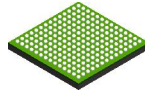

# PACKAGE OUTLINE

## NFBGA - 1.4 mm max height

PLASTIC BALL GRID ARRAY

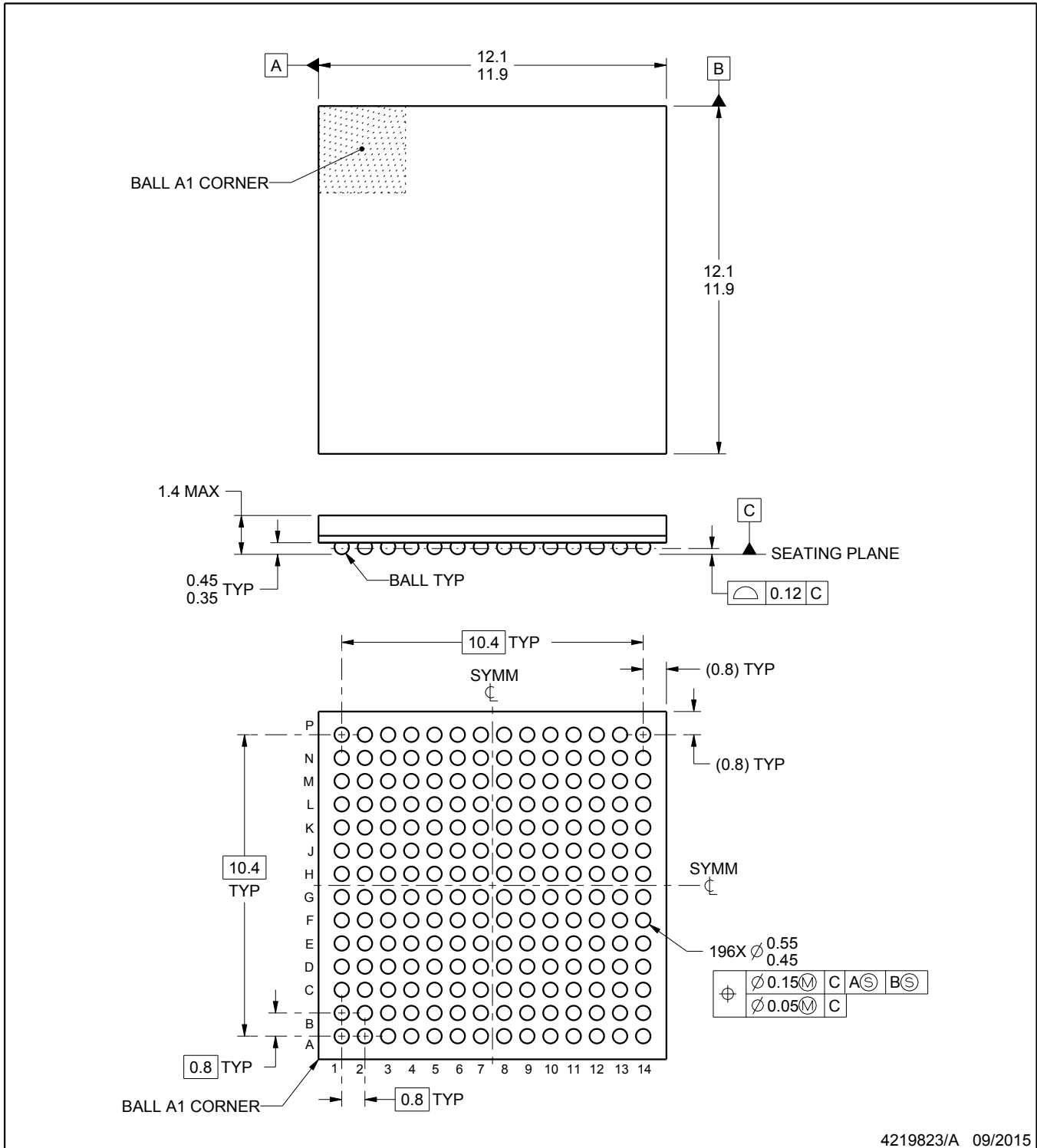

### NOTES:

1. All linear dimensions are in millimeters. Any dimensions in parenthesis are for reference only. Dimensioning and tolerancing per ASME Y14.5M.
2. This drawing is subject to change without notice.

# EXAMPLE BOARD LAYOUT

ZAY0196A

NFBGA - 1.4 mm max height

PLASTIC BALL GRID ARRAY

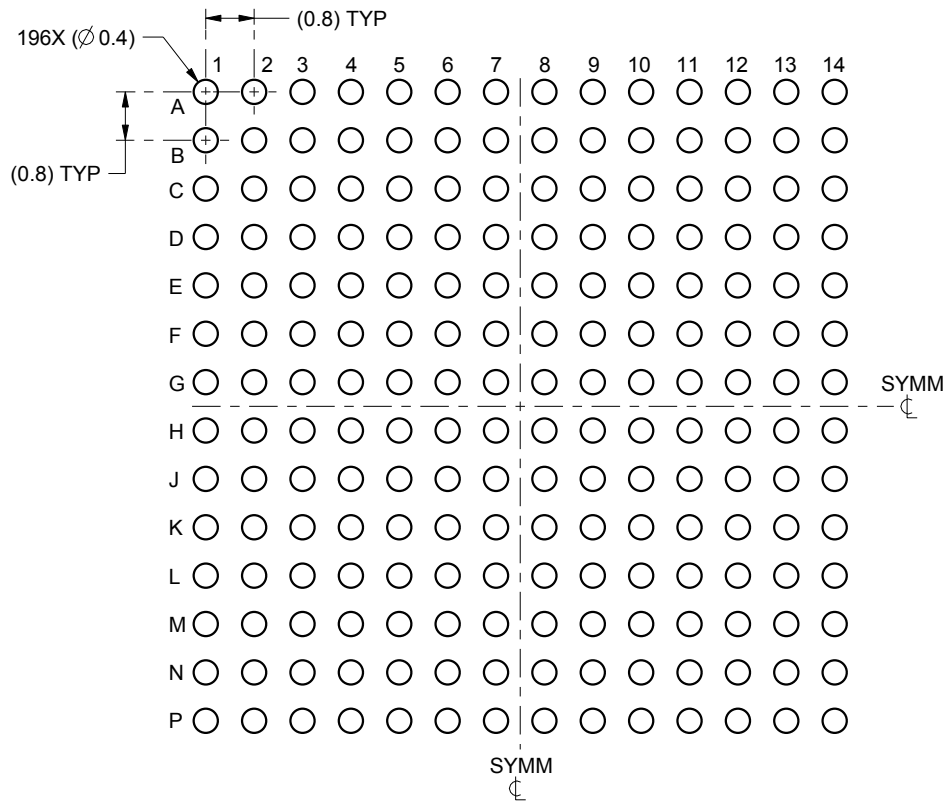

LAND PATTERN EXAMPLE  
SCALE:8X

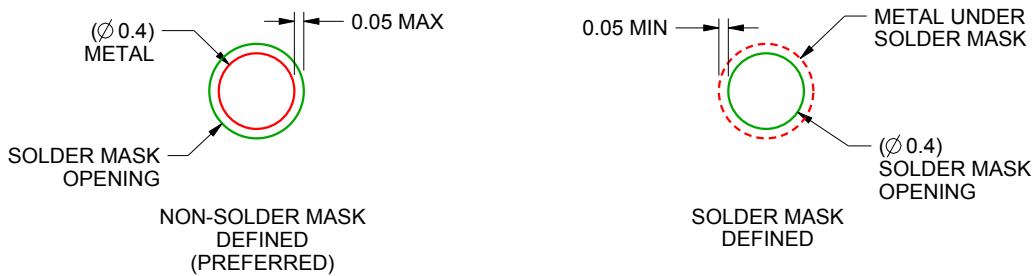

SOLDER MASK DETAILS  
NOT TO SCALE

4219823/A 09/2015

NOTES: (continued)

- Final dimensions may vary due to manufacturing tolerance considerations and also routing constraints. For information, see Texas Instruments literature number SPRAA99 ([www.ti.com/lit/spraa99](http://www.ti.com/lit/spraa99)).

# EXAMPLE STENCIL DESIGN

ZAY0196A

NFBGA - 1.4 mm max height

PLASTIC BALL GRID ARRAY

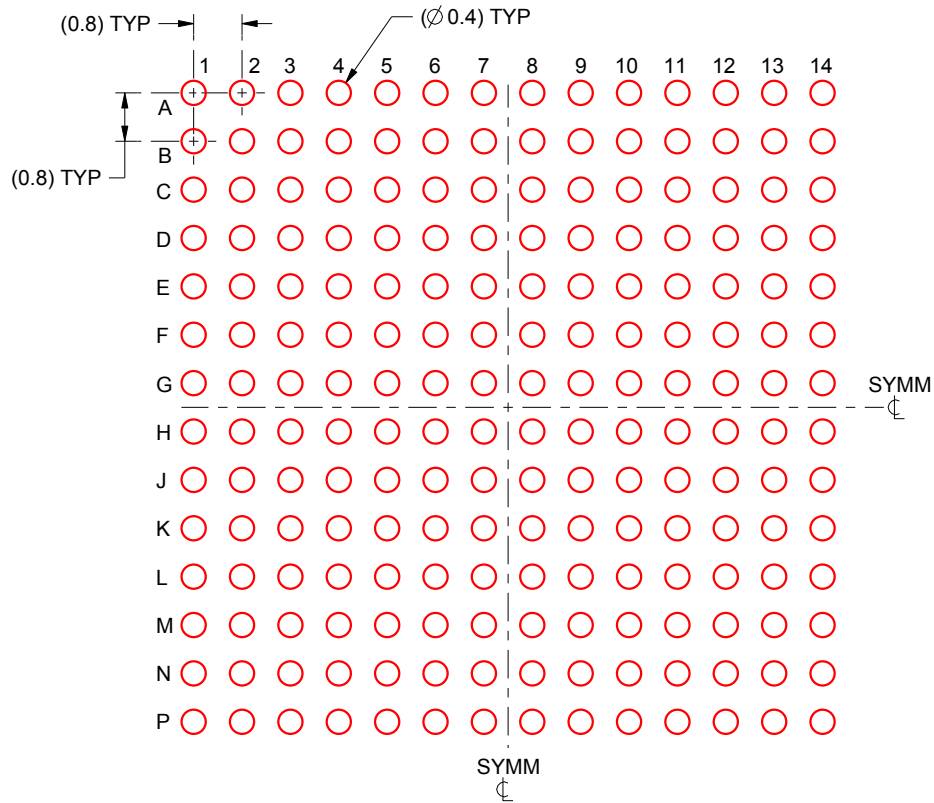

SOLDER PASTE EXAMPLE  
BASED ON 0.15 mm THICK STENCIL  
SCALE:8X

4219823/A 09/2015

NOTES: (continued)



4. Laser cutting apertures with trapezoidal walls and rounded corners may offer better paste release.

RKD (S-PWQFN-N88)

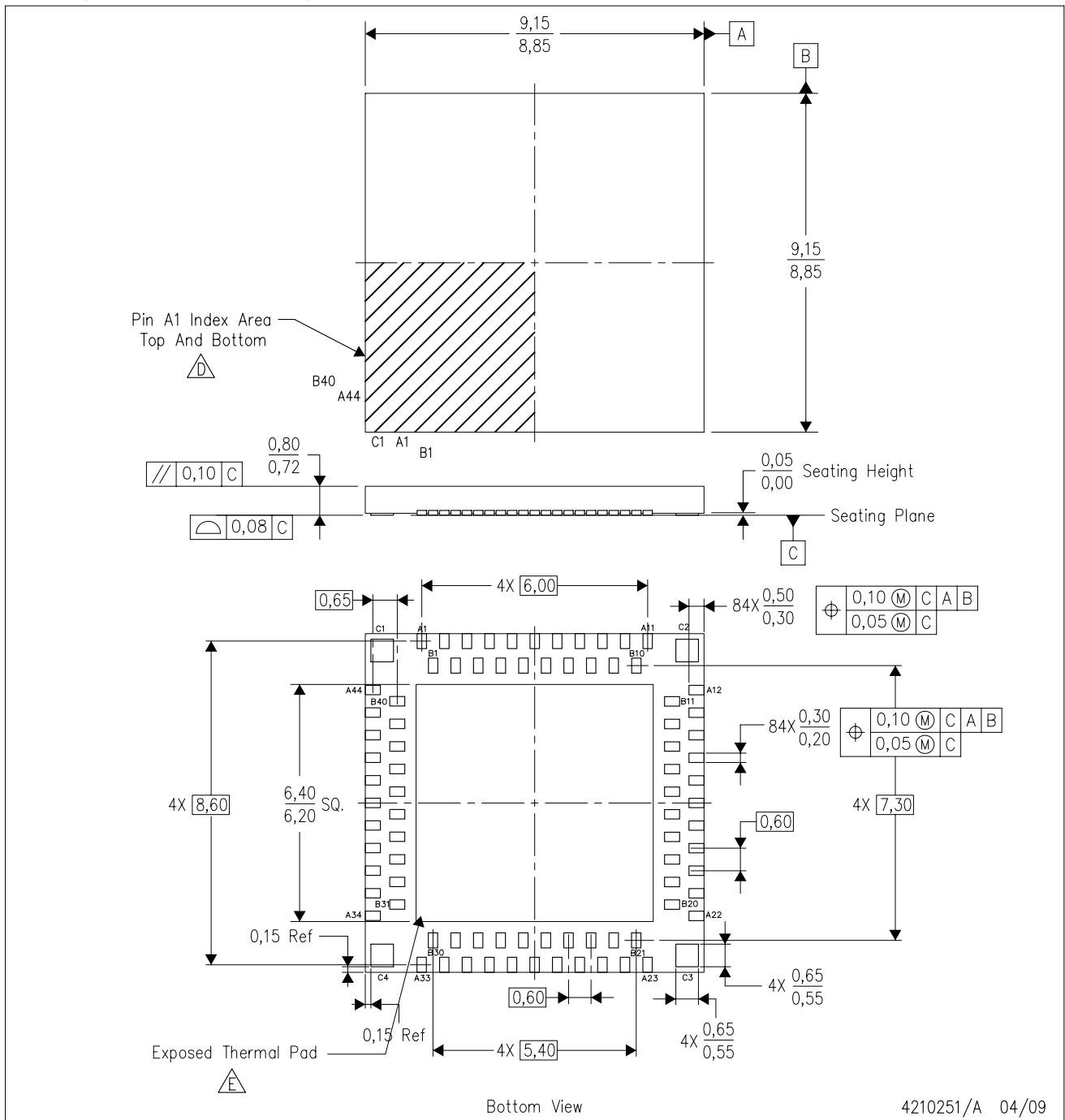
PLASTIC QUAD FLATPACK NO-LEAD



4210251/A 04/09

- NOTES:
- A. All linear dimensions are in millimeters. Dimensioning and tolerancing per ASME Y14.5M-1994.
  - B. This drawing is subject to change without notice.
  - C. QFN (Quad Flatpack No-Lead) staggered multi-row package configuration.
  -  Pin A1 identifiers are located on both top and bottom of the package and within the zone indicated. The Pin A1 identifiers are either a molded, marked, or metal feature.
  -  The package thermal pad must be soldered to the board for thermal and mechanical performance. See the Product Data Sheet for details regarding the exposed thermal pad dimensions.

# THERMAL PAD MECHANICAL DATA

RKD (S-MRQFN-N88)

PLASTIC QUAD FLATPACK NO-LEAD

## THERMAL INFORMATION

This package incorporates an exposed thermal pad that is designed to be attached directly to an external heatsink. The thermal pad must be soldered directly to the printed circuit board (PCB). After soldering, the PCB can be used as a heatsink. In addition, through the use of thermal vias, the thermal pad can be attached directly to the appropriate copper plane shown in the electrical schematic for the device, or alternatively, can be attached to a special heatsink structure designed into the PCB. This design optimizes the heat transfer from the integrated circuit (IC).

For information on the Quad Flatpack No-Lead (QFN) package and its advantages, refer to Application Report, QFN/SON PCB Attachment, Texas Instruments Literature No. SLUA271. This document is available at [www.ti.com](http://www.ti.com).

The exposed thermal pad dimensions for this package are shown in the following illustration.

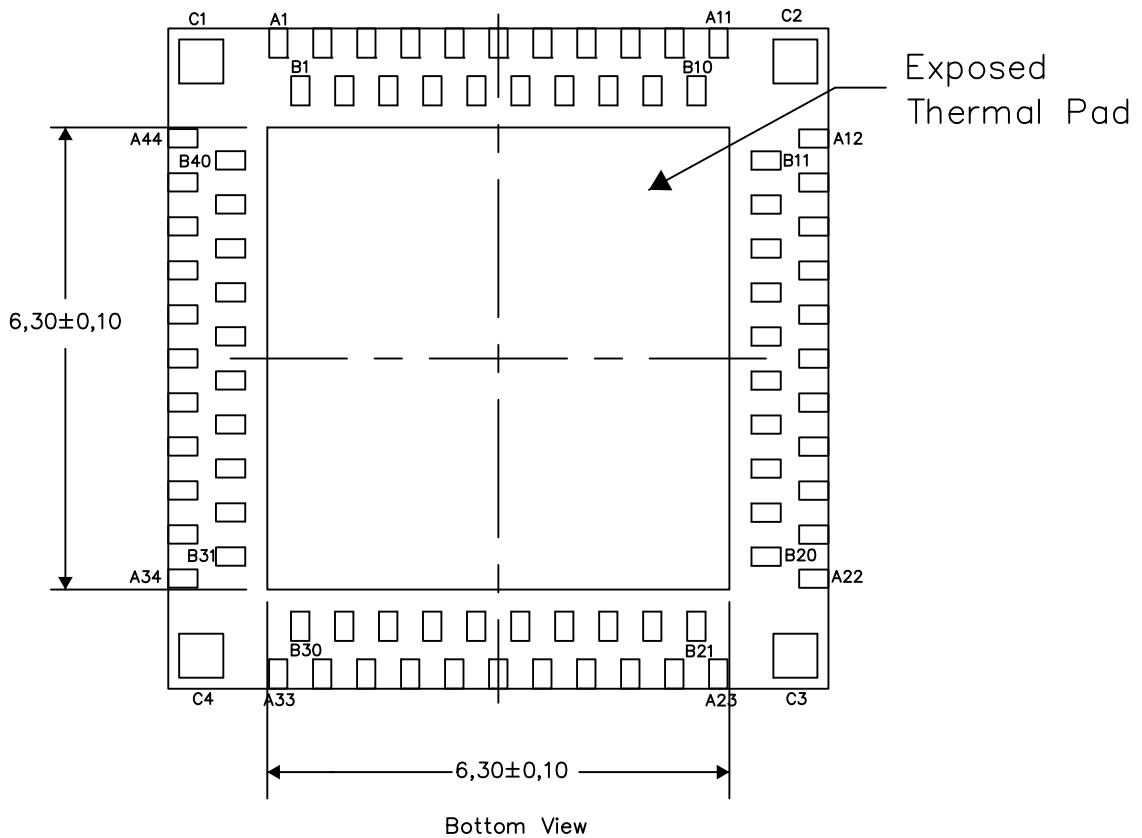

4210259/C 11/13

NOTE: All linear dimensions are in millimeters

RKD (S-MRQFN-N88)

PLASTIC QUAD FLATPACK NO-LEAD

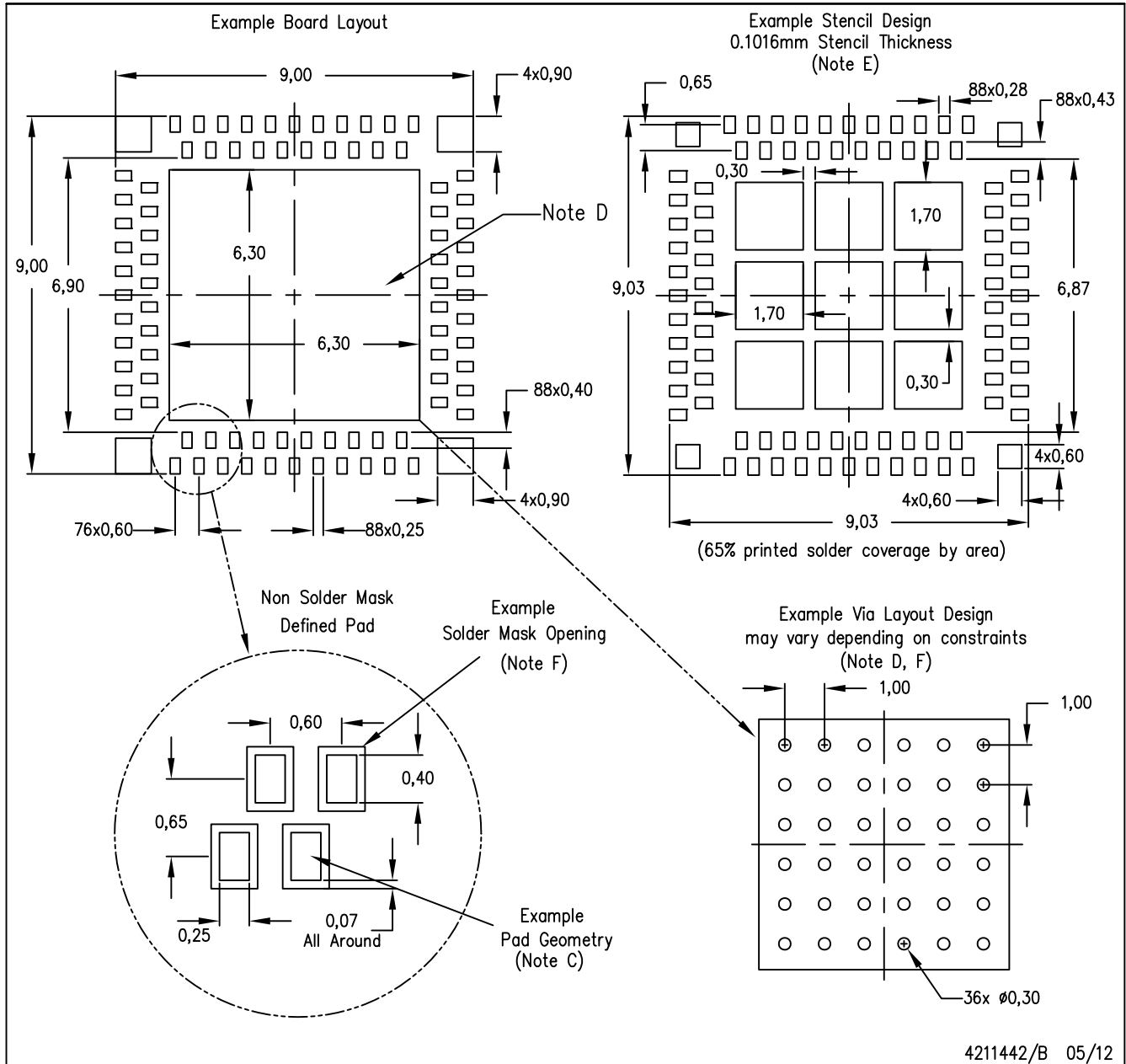

- NOTES:
- A. All linear dimensions are in millimeters.
  - B. This drawing is subject to change without notice.
  - C. Publication IPC-7351 is recommended for alternate designs.
  - D. This package is designed to be soldered to a thermal pad on the board. Refer to Application Note, Quad Flat-Pack Packages, Texas Instruments Literature No. SLUA271, and also the Product Data Sheets for specific thermal information, via requirements, and recommended board layout. These documents are available at [www.ti.com](http://www.ti.com) <<http://www.ti.com>>.
  - E. Laser cutting apertures with trapezoidal walls and also rounding corners will offer better paste release. Customers should contact their board assembly site for stencil design recommendations. Refer to IPC 7525 for stencil design considerations.
  - F. Customers should contact their board fabrication site for minimum solder mask web tolerances between signal pads.

## IMPORTANT NOTICE FOR TI DESIGN INFORMATION AND RESOURCES

Texas Instruments Incorporated ("TI") technical, application or other design advice, services or information, including, but not limited to, reference designs and materials relating to evaluation modules, (collectively, "TI Resources") are intended to assist designers who are developing applications that incorporate TI products; by downloading, accessing or using any particular TI Resource in any way, you (individually or, if you are acting on behalf of a company, your company) agree to use it solely for this purpose and subject to the terms of this Notice.

TI's provision of TI Resources does not expand or otherwise alter TI's applicable published warranties or warranty disclaimers for TI products, and no additional obligations or liabilities arise from TI providing such TI Resources. TI reserves the right to make corrections, enhancements, improvements and other changes to its TI Resources.

You understand and agree that you remain responsible for using your independent analysis, evaluation and judgment in designing your applications and that you have full and exclusive responsibility to assure the safety of your applications and compliance of your applications (and of all TI products used in or for your applications) with all applicable regulations, laws and other applicable requirements. You represent that, with respect to your applications, you have all the necessary expertise to create and implement safeguards that (1) anticipate dangerous consequences of failures, (2) monitor failures and their consequences, and (3) lessen the likelihood of failures that might cause harm and take appropriate actions. You agree that prior to using or distributing any applications that include TI products, you will thoroughly test such applications and the functionality of such TI products as used in such applications. TI has not conducted any testing other than that specifically described in the published documentation for a particular TI Resource.

You are authorized to use, copy and modify any individual TI Resource only in connection with the development of applications that include the TI product(s) identified in such TI Resource. NO OTHER LICENSE, EXPRESS OR IMPLIED, BY ESTOPPEL OR OTHERWISE TO ANY OTHER TI INTELLECTUAL PROPERTY RIGHT, AND NO LICENSE TO ANY TECHNOLOGY OR INTELLECTUAL PROPERTY RIGHT OF TI OR ANY THIRD PARTY IS GRANTED HEREIN, including but not limited to any patent right, copyright, mask work right, or other intellectual property right relating to any combination, machine, or process in which TI products or services are used. Information regarding or referencing third-party products or services does not constitute a license to use such products or services, or a warranty or endorsement thereof. Use of TI Resources may require a license from a third party under the patents or other intellectual property of the third party, or a license from TI under the patents or other intellectual property of TI.

TI RESOURCES ARE PROVIDED "AS IS" AND WITH ALL FAULTS. TI DISCLAIMS ALL OTHER WARRANTIES OR REPRESENTATIONS, EXPRESS OR IMPLIED, REGARDING TI RESOURCES OR USE THEREOF, INCLUDING BUT NOT LIMITED TO ACCURACY OR COMPLETENESS, TITLE, ANY EPIDEMIC FAILURE WARRANTY AND ANY IMPLIED WARRANTIES OF MERCHANTABILITY, FITNESS FOR A PARTICULAR PURPOSE, AND NON-INFRINGEMENT OF ANY THIRD PARTY INTELLECTUAL PROPERTY RIGHTS.

TI SHALL NOT BE LIABLE FOR AND SHALL NOT DEFEND OR INDEMNIFY YOU AGAINST ANY CLAIM, INCLUDING BUT NOT LIMITED TO ANY INFRINGEMENT CLAIM THAT RELATES TO OR IS BASED ON ANY COMBINATION OF PRODUCTS EVEN IF DESCRIBED IN TI RESOURCES OR OTHERWISE. IN NO EVENT SHALL TI BE LIABLE FOR ANY ACTUAL, DIRECT, SPECIAL, COLLATERAL, INDIRECT, PUNITIVE, INCIDENTAL, CONSEQUENTIAL OR EXEMPLARY DAMAGES IN CONNECTION WITH OR ARISING OUT OF TI RESOURCES OR USE THEREOF, AND REGARDLESS OF WHETHER TI HAS BEEN ADVISED OF THE POSSIBILITY OF SUCH DAMAGES.

You agree to fully indemnify TI and its representatives against any damages, costs, losses, and/or liabilities arising out of your non-compliance with the terms and provisions of this Notice.

This Notice applies to TI Resources. Additional terms apply to the use and purchase of certain types of materials, TI products and services. These include; without limitation, TI's standard terms for semiconductor products (<http://www.ti.com/sc/docs/stdterms.htm>), [evaluation modules](#), and [samples](http://www.ti.com/sc/docs/sampterm.htm) (<http://www.ti.com/sc/docs/sampterm.htm>).

Mailing Address: Texas Instruments, Post Office Box 655303, Dallas, Texas 75265  
Copyright © 2017, Texas Instruments Incorporated

## Looking for pricing, stock, or lifecycle information?

Click below to explore more details on WIN SOURCE:

 [View DAC3484IZAY on WIN SOURCE](#)

 [Texas Instruments](#) Information

## Optimize Your Supply Chain with WIN SOURCE Solutions

-  Global Sourcing Solution
-  Obsolete Management
-  Cost Control Management
-  Shortage Management
-  Alternative Solution
-  Excess Inventory Management