

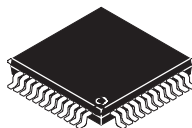

# THE DATASHEET OF DAC5674IPHP





---

## 14-BIT, 400 MSPS, 2×/4× INTERPOLATING CommsDAC™ DIGITAL-TO-ANALOG CONVERTER

---

### FEATURES

- 200-MSPS Maximum Input Data Rate
- 400-MSPS Maximum Update Rate DAC
- 76-dBc SFDR Over Full First Nyquist Zone With Single Tone Input Signal ( $F_{out} = 21$  MHz)
- 74-dBc ACPR W-CDMA at 15.36 MHz IF
- 69-dBc ACPR W-CDMA at 30.72 MHz IF
- Selectable 2× or 4× Interpolation Filter
  - Linear Phase
  - 0.05-dB Pass-Band Ripple
  - 80-dB Stop-Band Attenuation
  - Stop-Band Transition 0.4–0.6  $F_{data}$
  - Interpolation Filters Configurable in Either Low-Pass or High-Pass Mode, Allows For Selection High-Order Images
- On-Chip 2×/4× PLL Clock Multiplier, PLL Bypass Mode

- Differential Scalable Current Outputs: 2 mA to 20 mA
- On-Chip 1.2-V Reference
- 1.8-V Digital and 3.3-V Analog Supply Operation
- 1.8/3.3-V CMOS Compatible Interface
- Power Dissipation: 435 mW at 400 MSPS
- Package: 48-Pin TQFP

### APPLICATIONS

- Cellular Base Transceiver Station Transmit Channel
  - CDMA: W-CDMA, CDMA2000, IS-95
  - TDMA: GSM, IS-136, EDGE/UWC-136
- Test and Measurement: Arbitrary Waveform Generation
- Direct Digital Synthesis (DDS)
- Cable Modem Termination System

### DESCRIPTION

The DAC5674 is a 14-bit resolution, high-speed, digital-to-analog converter (DAC) with integrated 4× interpolation filter, onboard clock multiplier, and on-chip voltage reference. The device has been designed for high-speed digital data transmission in wired and wireless communication systems, high-frequency direct-digital synthesis (DDS) and waveform reconstruction in test and measurement applications.

The 4× interpolation filter is implemented as a cascade of two 2× interpolation filters, each of which can be configured for either low-pass or high-pass response. This enables the user to select one of the higher order images present at multiples of the input data rate clock while maintaining a low data input rate. The resulting high IF output frequency allows the user to omit the conventional first mixer in heterodyne transmitter architectures and directly up-convert to RF using only one mixer, thereby reducing system complexity and costs.

In 4× interpolation low-pass response mode, the DACs excellent spurious free dynamic range (SFDR) at intermediate frequencies located in the first Nyquist zone (up to 40 MHz) allows for multicarrier transmission in cellular base transceiver stations (BTS). The low-pass interpolation mode thereby relaxes image filter requirements by filtering out the images in the adjacent Nyquist zones.

The DAC5674 PLL clock multiplier controls all internal clocks for the digital filters and DAC core. The differential clock input and internal clock circuitry provides for optimum jitter performance. Sine wave clock input signal is supported. The PLL can be bypassed by an external clock running at the DAC core update rate. The clock divider of the PLL ensures that the digital filters operate at the correct clock frequencies.



Please be aware that an important notice concerning availability, standard warranty, and use in critical applications of Texas Instruments semiconductor products and disclaimers thereto appears at the end of this data sheet.

Excel is a trademark of Microsoft Corporation.

CommsDAC and PowerPAD are trademarks of Texas Instruments.

All other trademarks are the property of their respective owners.

# DAC5674

SLWS148A – SEPTEMBER 2003 – REVISED OCTOBER 2005



These devices have limited built-in ESD protection. The leads should be shorted together or the device placed in conductive foam during storage or handling to prevent electrostatic damage to the MOS gates.

The DAC5674 operates from an analog supply voltage of 3.3 V and a digital supply voltage of 1.8 V. The digital I/Os are 1.8-V and 3.3-V CMOS compatible. Power dissipation is 500 mW at maximum operating conditions. The DAC5674 provides a nominal full-scale differential current-output of 20 mA, supporting both single-ended and differential applications. The output current can be directly fed to the load with no additional external output buffer required. The device has been specifically designed for a differential transformer coupled output with a 50-Ω doubly terminated load. For a 20-mA full-scale output current, both a 4:1 impedance ratio (resulting in an output power of 4 dBm) and 1:1 impedance ratio transformer (–2-dBm output power) are supported. The latter configuration is preferred for optimum performance at high output frequencies and update rates.

An accurate on-chip 1.2-V temperature compensated band-gap reference and control amplifier allows the user to adjust the full-scale output current from 20 mA down to 2 mA. This provides 20-dB gain range control capabilities. Alternatively, an external reference voltage may be applied for maximum flexibility. The device features a SLEEP mode, which reduces the standby power to approximately 10 mW, thereby optimizing the power consumption for the system's need.

The DAC5674 is available in a 48-pin HTQFP PowerPAD™ plastic quad flatpack package. The device is characterized for operation over the industrial temperature range of –40°C to 85°C.

## AVAILABLE OPTIONS

T <sub>A</sub>	PACKAGED DEVICES
–40°C to 85°C	48-HTQFP PowerPAD Plastic Quad Flatpack
	DAC5674IPHP
	DAC5674IPHPR

## ABSOLUTE MAXIMUM RATINGS

over operating free-air temperature range unless otherwise noted<sup>(1)</sup>

		UNIT
Supply voltage range	AVDD <sup>(2)</sup> , CLKVDD <sup>(2)</sup> , IOVDD <sup>(2)</sup> , PLLVDD <sup>(2)</sup>	–0.5 V to 4 V
	DVDD <sup>(3)</sup>	–0.5 V to 2.3 V
Voltage between AGND, DGND, CLKGND, PLLGND, and IOGND		–0.5 V to 0.5 V
Supply voltage range	D[13..0] <sup>(3)</sup> , HP1, HP2, DIV0 <sup>(3)</sup> , DIV1 <sup>(3)</sup> , PLLLOCK <sup>(3)</sup> , RESET <sup>(3)</sup> , X4 <sup>(3)</sup>	–0.5 V to IOVDD + 0.5 V
	IOUT1, IOUT2 <sup>(2)</sup>	–1 V to AVDD + 0.5 V
	EXTIO <sup>(2)</sup> , EXTLO <sup>(2)</sup> , BIASJ <sup>(2)</sup> , SLEEP <sup>(2)</sup> , CLK <sup>(2)</sup> , CLKC <sup>(2)</sup> , LPF <sup>(2)</sup>	–0.5 V to AVDD + 0.5 V
Peak input current (any input)		20 mA
Peak total input current (all inputs)		–30 mA
Operating free-air temperature range, T <sub>A</sub> : DAC5674I		–40°C to 85°C
Storage temperature range		–65°C to 150°C
Lead temperature 1,6 mm (1/16 inch) from the case for 10 seconds		260°C

(1) Stresses beyond those listed under “absolute maximum ratings” may cause permanent damage to the device. These are stress ratings only, and functional operation of the device at these or any other conditions beyond those indicated under “recommended operating conditions” is not implied. Exposure to absolute-maximum-rated conditions for extended periods may affect device reliability.

(2) Measured with respect to AGND.

(3) Measured with respect to DGND.

## DC ELECTRICAL CHARACTERISTICS

over recommended operating free-air temperature range, AVDD = 3.3 V, CLKVDD = 3.3 V, PLLVDD = 3.3 V, IOVDD = 3.3 V, DVDD = 1.8 V, IOUTFS = 20 mA, R<sub>Set</sub> = 1.91 kΩ, internal reference, unless otherwise noted

PARAMETER		TEST CONDITIONS	MIN	TYP	MAX	UNIT	
<b>RESOLUTION</b>			14			Bits	
<b>DC ACCURACY(1)</b>							
INL	Integral nonlinearity	1 LSB = IOUTFS/2 <sup>14</sup> , T <sub>MIN</sub> to T <sub>MAX</sub>	–3.5		3.5	LSB	
			–2.14e–4		2.14e–4	IOUTFS	
DNL	Differential nonlinearity		–2		2	LSB	
			–1.22e–4		1.22e–4	IOUTFS	
<b>Monotonicity</b>			Monotonic to 12 bits				
<b>ANALOG OUTPUT</b>							
Offset error			0.02			FSR	
Gain error	Without internal reference		2.3			%FSR	
	With internal reference		1.3				
Minimum full-scale output current(2)			2			mA	
Maximum full-scale output current(2)			20			mA	
Output compliance range(3)		IOUTFS = 20 mA	–1		1.25	V	
Output resistance			300			kΩ	
Output capacitance			5			pF	
<b>REFERENCE OUTPUT</b>							
Reference voltage			1.14	1.2	1.26	V	
Reference output current(4)			100			nA	
<b>REFERENCE INPUT</b>							
V <sub>EXTIO</sub>	Input voltage range		0.1		1.25	V	
	Input resistance		1			MΩ	
Small signal bandwidth			1.4			MHz	
Input capacitance			100			pF	
<b>TEMPERATURE COEFFICIENTS</b>							
Offset drift			0			ppm of FSR/°C	
Gain drift	Without internal reference		±50			ppm of FSR/°C	
	With internal reference		±100			ppm of FSR/°C	
Reference voltage drift			±50			ppm/°C	
<b>POWER SUPPLY</b>							
AVDD	Analog supply voltage		3	3.3	3.6	V	
DVDD	Digital supply voltage		1.65	1.8	1.95	V	
CLKVDD	Clock supply voltage		3	3.3	3.6	V	
IOVDD	I/O supply voltage		1.65		3.6	V	
PLLVDD	PLL supply voltage		3	3.3	3.6	V	
I <sub>AVDD</sub>	Analog supply current		Including output current through the load resistor, AVDD = 3.3 V, DVDD = 1.8 V, 4× interpolation, PLL on, 9-MHz IF, 400 MSPS		41	55	mA

Specifications subject to change without notice.

(1) Measured differentially across IOUT1 and IOUT2 into 50 Ω.

(2) Nominal full-scale current, IOUTFS, equals 32× the IBIAS current.

(3) The lower limit of the output compliance is determined by the CMOS process. Exceeding this limit may result in transistor breakdown, resulting in reduced reliability of the DAC5674 device. The upper limit of the output compliance is determined by the load resistors and full-scale output current. Exceeding the upper limit adversely affects distortion performance and integral nonlinearity.

(4) Use an external buffer amplifier with high impedance input to drive any external load.

# DAC5674

SLWS148A – SEPTEMBER 2003 – REVISED OCTOBER 2005

## DC ELECTRICAL CHARACTERISTICS (CONTINUED)

 over recommended operating free-air temperature range, AVDD = 3.3 V, CLKVDD = 3.3 V, PLLVDD = 3.3 V, IOVDD = 3.3 V, DVDD = 1.8 V, IOUTFS = 20 mA, R<sub>Set</sub> = 1.91 k $\Omega$ , internal reference, unless otherwise noted

PARAMETER		TEST CONDITIONS	MIN	TYP	MAX	UNIT
<b>POWER SUPPLY (CONTINUED)</b>						
I <sub>DVDD</sub>	Digital supply current	AVDD = 3.3 V, DVDD = 1.8 V, 4 $\times$ interpolation, PLL on, 9-MHz IF, 400 MSPS		107	140	mA
I <sub>SLEEP3.3</sub>	Sleep mode	Sleep mode, supply current 3.3 V		6	12	mA
I <sub>SLEEP1.8</sub>	Sleep mode	Sleep mode, supply current 1.8 V		0.5	3	mA
I <sub>PLLVDD</sub>	PLL supply current <sup>(1)</sup>	F <sub>data</sub> = 100 MSPS, F <sub>update</sub> = 400 MSPS, DIV[1:0] = '00', AVDD = 3.3 V, DVDD = 1.8 V, 4 $\times$ interpolation, PLL on, 9-MHz IF, 400 MSPS		23	35	mA
I <sub>IOVDD</sub>	Buffer supply current	AVDD = 3.3 V, DVDD = 1.8 V, 4 $\times$ interpolation, PLL on, 9-MHz IF, 400 MSPS		4	10	mA
I <sub>CLKVDD</sub>	Clock supply current <sup>(1)</sup>	AVDD = 3.3 V, DVDD = 1.8 V, 4 $\times$ interpolation, PLL on, 9-MHz IF, 400 MSPS		6	10	mA
P <sub>D</sub>	Power dissipation	AVDD = 3.3 V, DVDD = 1.8 V, 4 $\times$ interpolation, PLL on, 9-MHz IF, 400 MSPS		435	550	mW
APSR	Power supply rejection ratio		-0.2		0.2	%FSR/V
DPSRR			-0.2		0.2	
Operating range			-40		85	$^{\circ}$ C

Specifications subject to change without notice.

(1) PLL enabled

## AC ELECTRICAL CHARACTERISTICS

 over recommended operating free-air temperature range, AVDD = 3.3 V, CLKVDD = 3.3 V, PLLVDD = 3.3 V, IOVDD = 1.8 V, DVDD = 1.8 V, IOUTFS = 20 mA, differential transformer coupled output, 50- $\Omega$  doubly terminated load (unless otherwise noted)

PARAMETER		TEST CONDITIONS	MIN	TYP	MAX	UNIT
<b>ANALOG OUTPUT</b>						
f <sub>CLK</sub>	Maximum output update rate		400			MSPS
t <sub>s</sub> (DAC)	Output settling time to 0.1%	Midscale transition		20		ns
t <sub>r</sub> (IOUT)	Output rise time 10% to 90% <sup>(1)</sup>			1.4		ns
t <sub>f</sub> (IOUT)	Output fall time 90% to 10% <sup>(1)</sup>			1.5		ns
Output noise		IOUTFS = 20 mA		55		pA/ $\sqrt{\text{HZ}}$
		IOUTFS = 2 mA		30		
<b>AC LINEARITY 1:1 IMPEDANCE RATIO TRANSFORMER (ALL AC MEASUREMENTS PLLVDD = 0 V)</b>						
SFDR	Spurious free dynamic range (First Nyquist zone < f <sub>DATA</sub> /2) X4 LL-mode	f <sub>DATA</sub> = 52 MSPS, f <sub>OUT</sub> = 14 MHz, T <sub>A</sub> = 25 $^{\circ}$ C		85		dBc
		f <sub>DATA</sub> = 100 MSPS, f <sub>OUT</sub> = 21 MHz, T <sub>MIN</sub> to T <sub>MAX</sub>		76		
		f <sub>DATA</sub> = 100 MSPS, f <sub>OUT</sub> = 41 MHz, T <sub>MIN</sub> to T <sub>MAX</sub>		71		
SNR	Signal-to-noise ratio (First Nyquist zone < f <sub>DATA</sub> /2) X4 LL-mode	f <sub>DATA</sub> = 78 MSPS, f <sub>OUT</sub> = 20 MHz, T <sub>MIN</sub> to T <sub>MAX</sub>		71		dB
		f <sub>DATA</sub> = 100 MSPS, f <sub>OUT</sub> = 20 MHz, T <sub>MIN</sub> to T <sub>MAX</sub>		70		
ACPR	Adjacent channel power ratio W-CDMA signal with 3.84-MHz BW 5-MHz channel spacing	f <sub>DATA</sub> = 61.44 MSPS, IF = 15.360 MHz, X4 LL-mode		74		dB
		f <sub>DATA</sub> = 122.88 MSPS, IF = 30.72 MHz, X2 L-mode		69		
IMD3	Third-order, two-tone intermodulation (each tone at -6 dBFS)	f <sub>DATA</sub> = 61.44 MSPS, f <sub>OUT</sub> = 45.4 and 46.4 MHz, X4 HL-mode		68		dBc
		f <sub>DATA</sub> = 61.44 MSPS, f <sub>OUT</sub> = 15.1 and 16.1 MHz, X4 LL-mode		82		
IMD	Four-tone Intermodulation to Nyquist (each tone at -12 dBFS)	f <sub>DATA</sub> = 78 MSPS f <sub>OUT</sub> = 15.6 MHz, 15.8 MHz, 16.2 MHz, 16.4 MHz, X4 LL-mode		76		dBc
		f <sub>DATA</sub> = 52 MSPS f <sub>OUT</sub> = 68.8 MHz, 69.6 MHz, 71.2 MHz, 72 MHz, X4 HH-mode		64		

 (1) Measured single-ended into 50- $\Omega$  load.

**ELECTRICAL CHARACTERISTICS**

over recommended operating free-air temperature range, AVDD = 3.3 V, CLKVDD = 3.3 V, PLLVDD = 3.3 V, IOVDD = 3.3 V, DVDD = 1.8 V, IOUTFS = 20 mA, differential transformer coupled output, 50-Ω doubly terminated load (unless otherwise noted)

<b>DIGITAL SPECIFICATIONS</b>						
<b>PARAMETER</b>		<b>TEST CONDITIONS</b>	<b>MIN</b>	<b>TYP</b>	<b>MAX</b>	<b>UNIT</b>
<b>CMOS INTERFACE</b>						
V <sub>IH</sub>	High-level input voltage for SLEEP and EXTLO		0.7 AV <sub>DD</sub>			V
V <sub>IL</sub>	Low-level input voltage for SLEEP and EXTLO		0	0.3 AV <sub>DD</sub>		V
V <sub>IH</sub>	High-level input voltage other digital inputs		0.7 IOV <sub>DD</sub>			V
V <sub>IL</sub>	Low-level input voltage other digital inputs		0	0.3 IOV <sub>DD</sub>		V
I <sub>IH</sub>	High-level input current		10	30		μA
I <sub>IL</sub>	Low-level input current		-1	10		μA
	Input capacitance		1	5		pF
<b>TIMING INTERNAL CLOCK MODE</b>						
t <sub>SU</sub>	Input setup time		0.6			ns
t <sub>H</sub>	Input hold time		0.6			ns
t <sub>LPH</sub>	Input latch pulse high time		2			ns
t <sub>lat_2x</sub>	Data in to DAC out latency – 2× interpolation		26			clk
t <sub>lat_4x</sub>	Data in to DAC out latency – 4× interpolation		35			clk
<b>TIMING – EXTERNAL CLOCK MODE</b>						
t <sub>su</sub>	Input setup time		5			ns
t <sub>h</sub>	Input hold time		-1.75			ns
t <sub>lph</sub>	Input latch pulse high time		2			ns
t <sub>d_clk</sub>	Clock delay time		3.6			ns
t <sub>lat_2x</sub>	Data in to DAC out latency – 2× interpolation		26			clk
t <sub>lat_4x</sub>	Data in to DAC out latency – 4× interpolation		35			clk
<b>PLL</b>						
	Input data rate supported		5	200		MSPS
	Phase noise	At 600-kHz offset	-124			dBc/Hz
		At 6-MHz offset	-134			
<b>DIGITAL FILTER SPECIFICATIONS</b>						
f <sub>DATA</sub>	Input data rate		200			MSPS
<b>FIR1 and FIR2 DIGITAL FILTER CHARACTERISTICS</b>						
Pass-band width		0.005 db	0.407		f <sub>OUT</sub> / f <sub>DATA</sub>	
		0.01 dB	0.41			
		0.1 dB	0.427			
		3 dB	0.481			

# DAC5674

SLWS148A – SEPTEMBER 2003 – REVISED OCTOBER 2005

## PINOUT DIAGRAM

PHP PACKAGE  
(TOP VIEW)

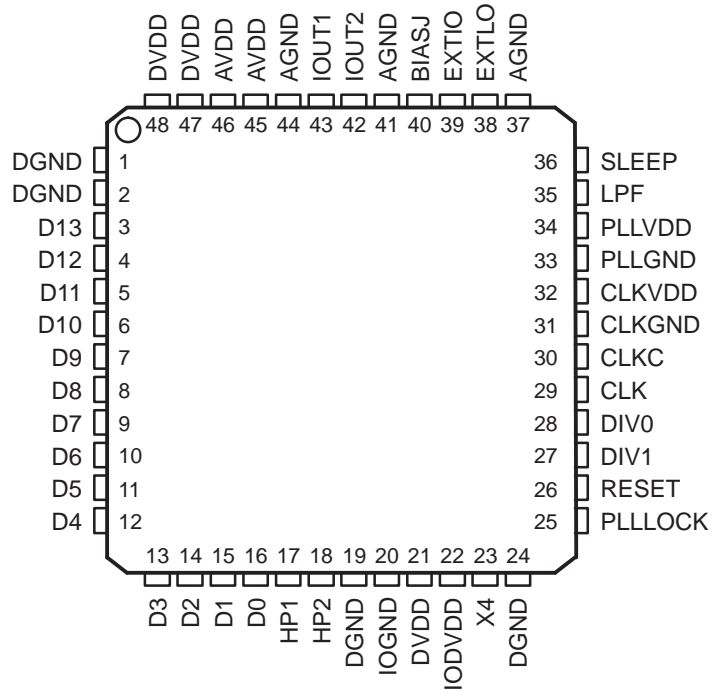

## Terminal Functions

TERMINAL		I/O	DESCRIPTION
NAME	NO.		
AGND	37, 41, 44	I	Analog ground return
AVDD	45, 46	I	Analog supply voltage
BIASJ	40	O	Full-scale output current bias
CLK	29	I	External clock input
CLKC	30	I	Complementary external clock input
CLKGND	31	I	Ground return for internal clock buffer
CLKVDD	32	I	Internal clock buffer supply voltage
D[13..0]	3–16	I	Data bits 0 through 13 D13 is most significant data bit (MSB) D0 is least significant data bit (MSB)
DIV[1..0]	27,28	I	PLL prescaler divide ratio settings
DGND	1, 2, 19, 24	I	Digital ground return
DVDD	21, 47, 48	I	Digital supply voltage
EXTIO	39	I/O	Used as external reference input when internal reference is disabled (i.e., EXTLO connected to AVDD). Used as internal reference output when EXTLO = AGND, requires a 0.1- $\mu$ F decoupling capacitor to AGND when used as reference output
EXTLO	38	I	For internal reference connect to AGND. Connect to AVDD to disable the internal reference
HP1	17	I	Filter 1 high-pass setting. Active high
HP2	18	I	Filter 2 high-pass setting. Active high
IOGND	20	I	Input digital ground return
IODVDD	22	I	Input digital supply voltage
IOUT1	43	O	DAC current output. Full scale when all input bits are set 1
IOUT2	42	O	DAC complementary current output. Full scale when all input bits are 0
LPF	35	I	PLL loop filter connection
PLLGND	33	I	Ground return for internal PLL
PLLLOCK	25	O	PLL lock status bit. PLL is locked to input clock when high. Provides output clock equal to the data rate when the PLL is disabled.
PLLVDD	34	I	Internal PLL supply voltage. Connect to PLLGND to disable PLL clock multiplier.
RESET	26	I	Reset internal registers. Active high
SLEEP	36	I	Asynchronous hardware power-down input. Active high. Internally pull down.
X4	23	I	4 $\times$ interpolation mode. Active high. Filter 1 is bypassed when connected to DGND

# DAC5674

SLWS148A – SEPTEMBER 2003 – REVISED OCTOBER 2005

## FUNCTIONAL BLOCK DIAGRAM

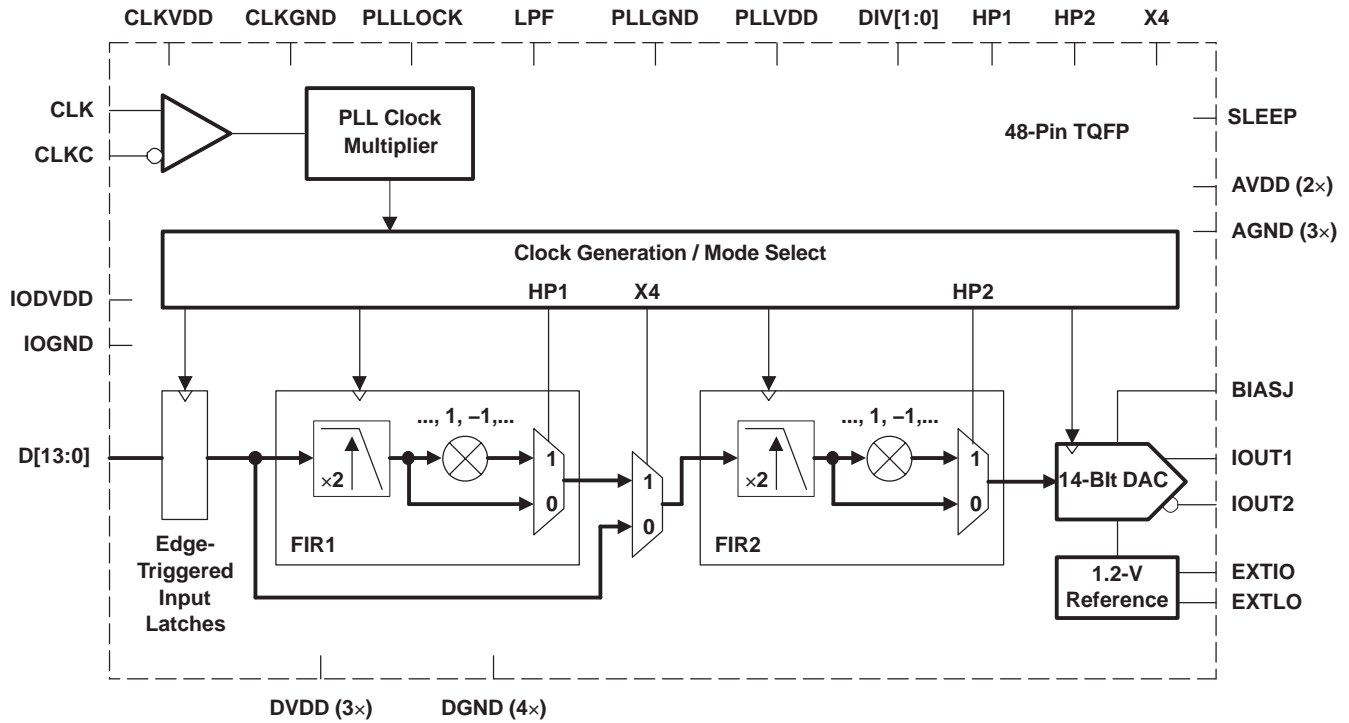

Figure 1. Block Diagram

## TYPICAL CHARACTERISTICS

### INTEGRAL NONLINEARITY VS INPUT CODE

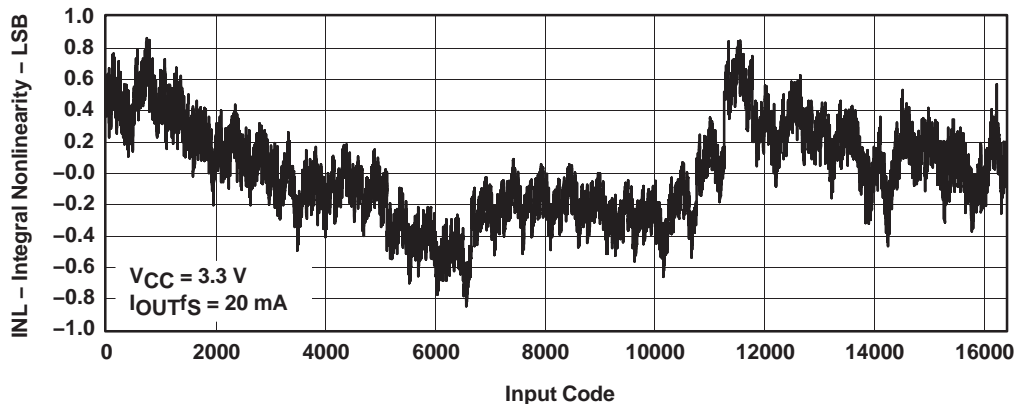

Figure 2

### DIFFERENTIAL NONLINEARITY VS INPUT CODE

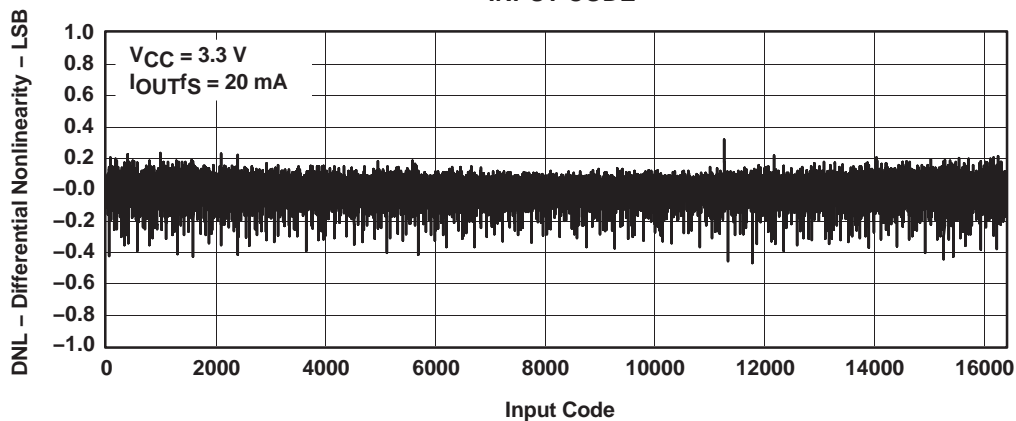

Figure 3

DAC5674

SLWS148A – SEPTEMBER 2003 – REVISED OCTOBER 2005

SPURIOUS-FREE DYNAMIC RANGE  
vs  
OUTPUT FREQUENCY

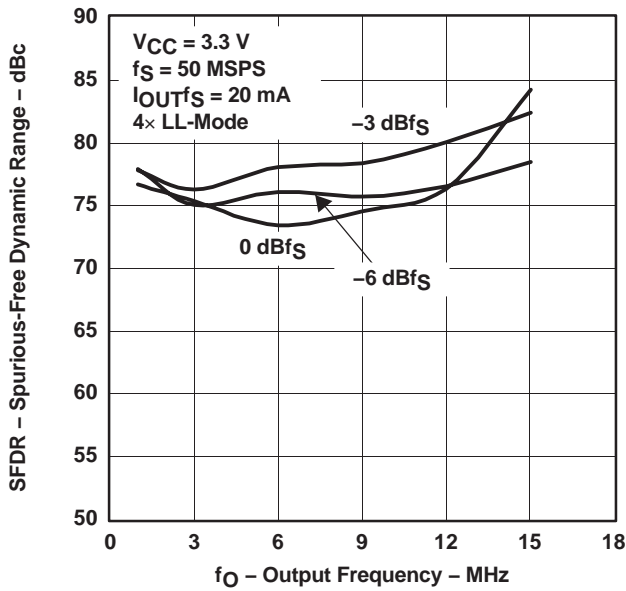

Figure 4

SPURIOUS-FREE DYNAMIC RANGE  
vs  
OUTPUT FREQUENCY

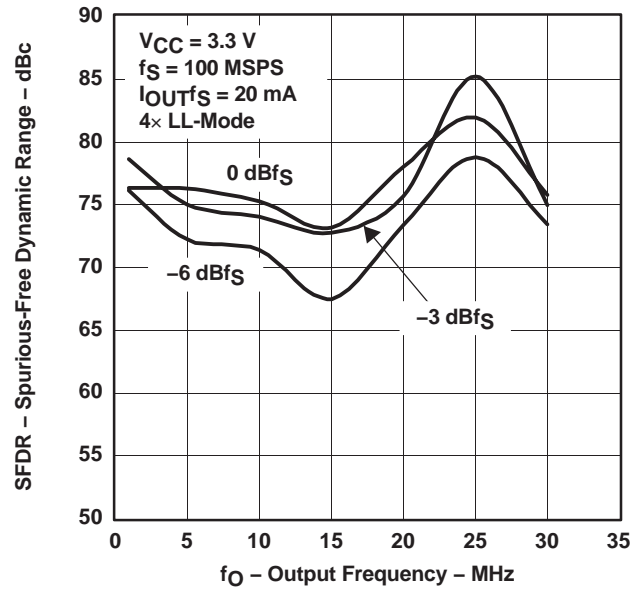

Figure 5

POWER  
vs  
FREQUENCY

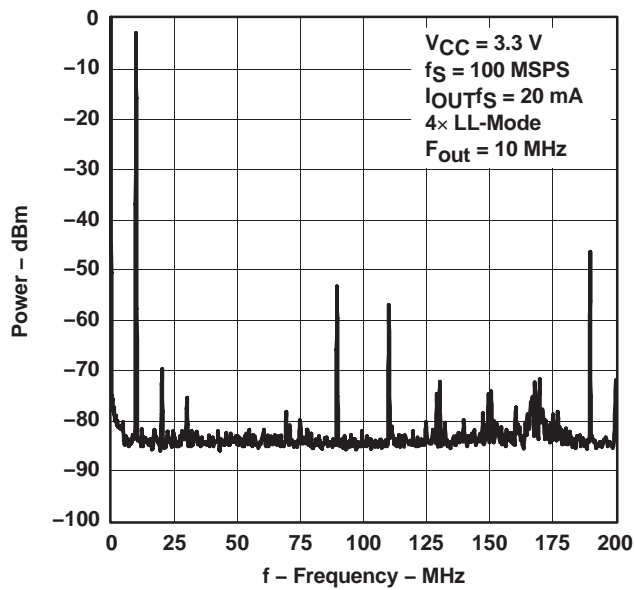

Figure 6

IN-BAND  
SPURIOUS-FREE DYNAMIC RANGE  
vs  
OUTPUT FREQUENCY

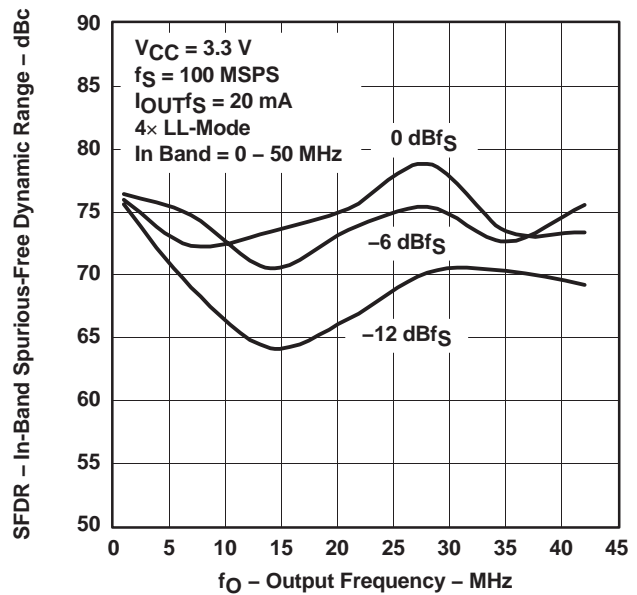

Figure 7

NOTE: All measurements made with PLL off.

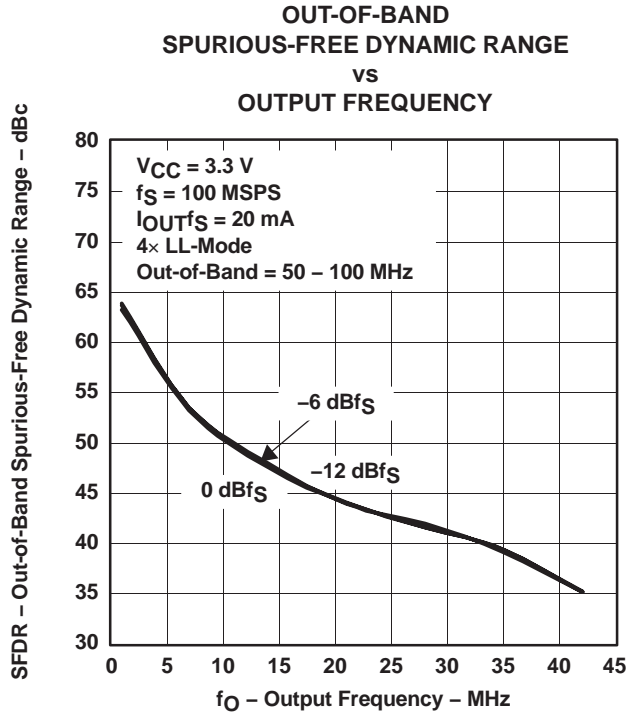

Figure 8

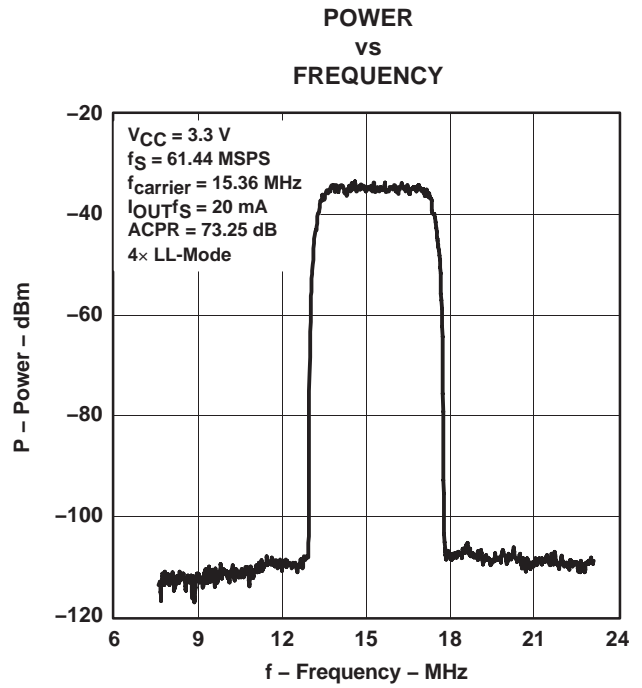

Figure 9

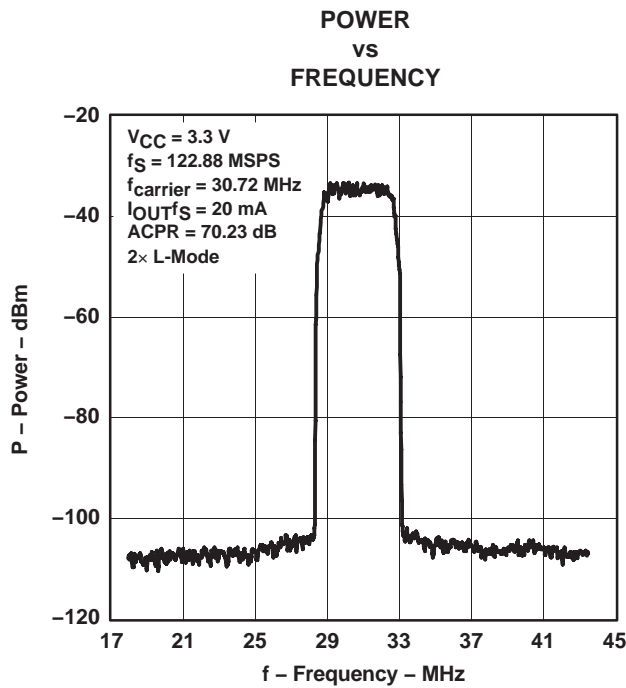

Figure 10

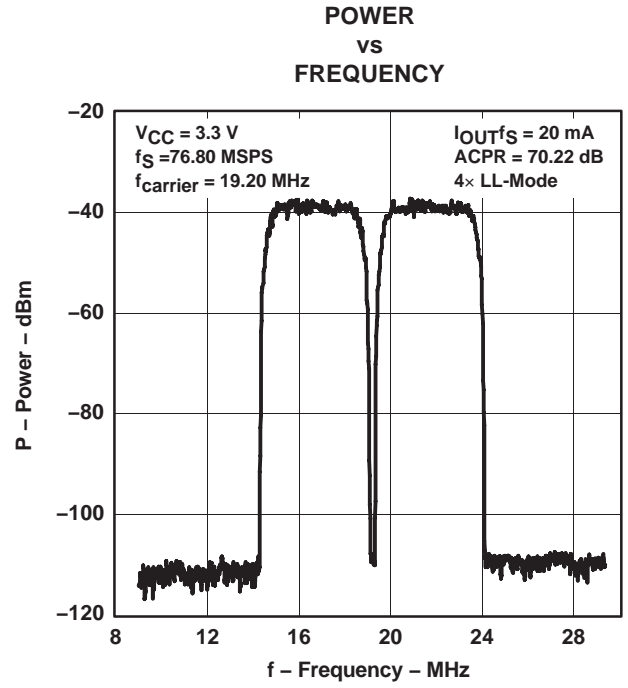

Figure 11

NOTE: All measurements made with PLL off.

DAC5674

SLWS148A – SEPTEMBER 2003 – REVISED OCTOBER 2005

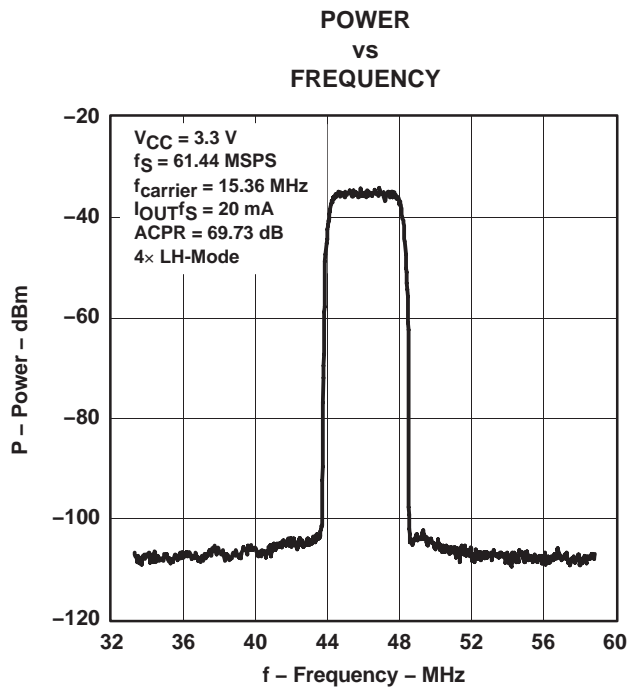

Figure 12

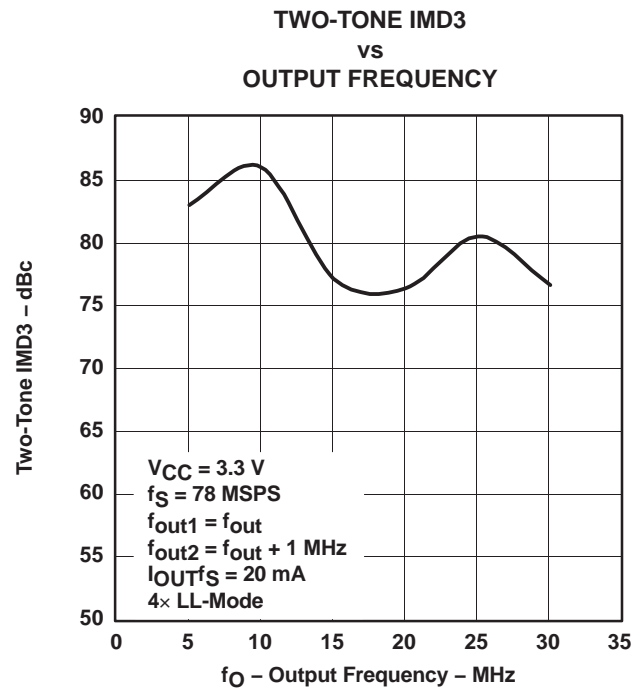

Figure 13

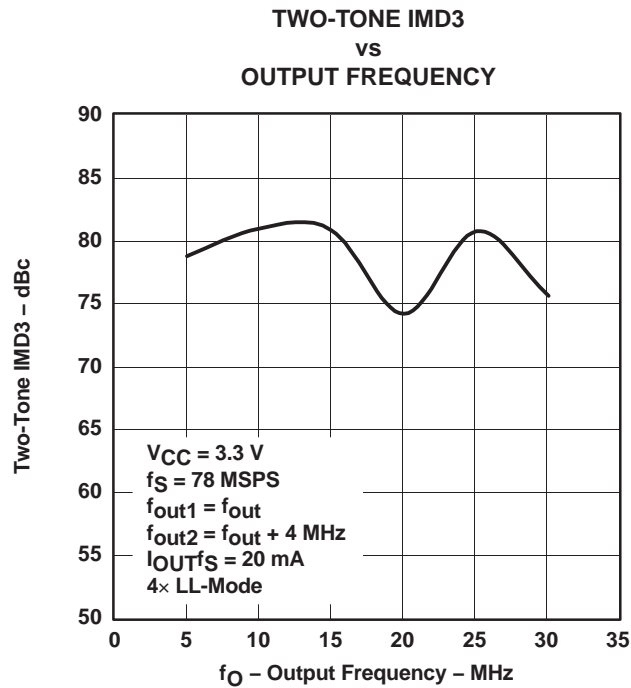

Figure 14

NOTE: All measurements made with PLL off.

## DETAILED DESCRIPTION

Figure 1 shows a simplified block diagram of the DAC5674. The CMOS device consists of a segmented array of PMOS current sources, capable of delivering a full-scale output current up to 20 mA. Differential current switches direct the current of each current source to either one of the complementary output nodes IOUT1 or IOUT2. The complementary output currents thus enable differential operation, canceling out common mode noise sources (digital feedthrough, on-chip, and PCB noise), dc offsets, even-order distortion components, and increase signal output power by a factor of two.

The full-scale output current is set using an external resistor  $R_{BIAS}$  in combination with an on-chip band-gap voltage reference source (1.2 V) and control amplifier. The current  $I_{BIAS}$  through resistor  $R_{BIAS}$  is mirrored internally to provide a full-scale output current equal to 32 times  $I_{BIAS}$ . The full-scale current can be adjusted from 20 mA down to 2 mA.

### Interpolation Filter

The interpolation filters FIR1 and FIR2 can be configured for either low-pass or high-pass response. In this way, higher order images can be selected. Table 1 shows the DAC IF output range for the different filter response combinations, for both the first and second Nyquist zone (after interpolation). Table 2 lists the DAC IF output ranges for two popular GSM data rates. Table 3 shows the W-CDMA IF carrier center frequency for an input data rate of 61.44 MSPS and a fundamental input IF of 15.36 MHz. Figure 15 shows the spectral response; the corresponding nonzero tap weights are:

- [5, -20, 50, -108, 206, -361, 597, -947, 1467, -2267, 3633, -6617, 20746, 32768]

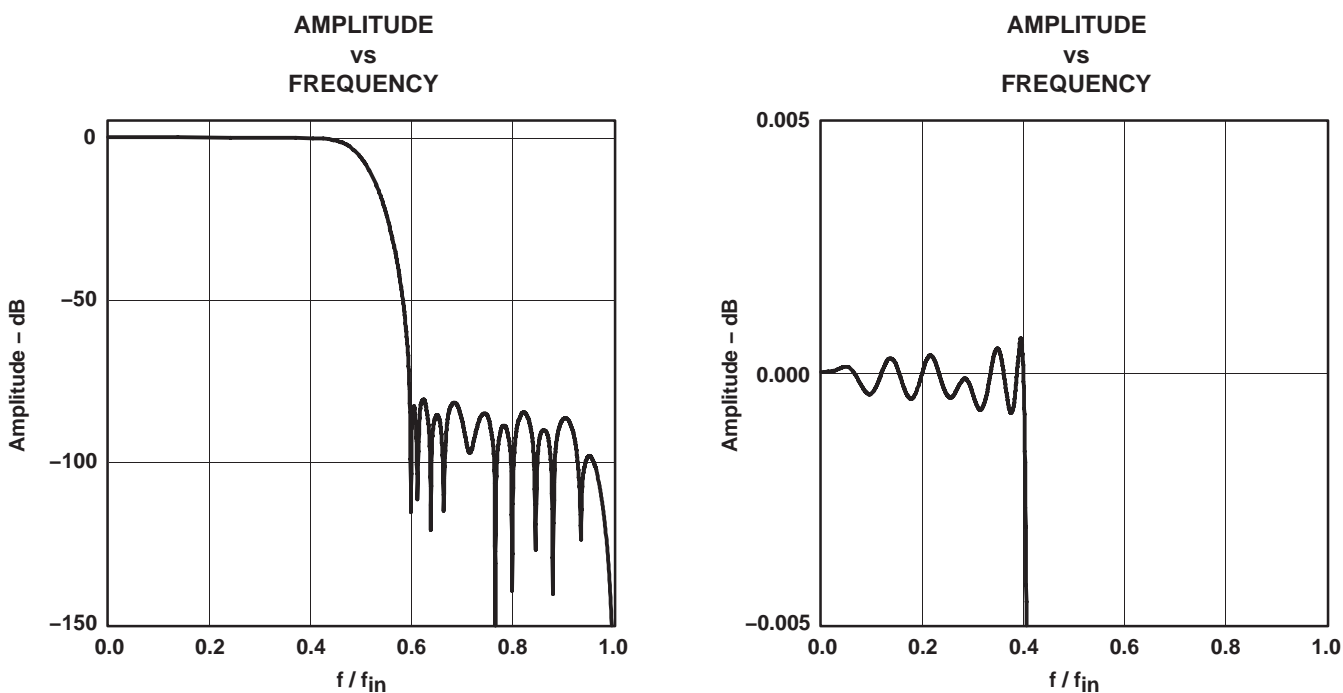

Figure 15. FIR1 and FIR2 Magnitude Spectrum

**Table 1. Interpolation Filters Configuration**

FILTER 1 CONFIGURATION	FILTER 2 CONFIGURATION	IF OUTPUT RANGE 1 (FIRST NYQUIST ZONE)		IF OUTPUT RANGE 2 (SECOND NYQUIST ZONE)	
		FREQUENCY	SINX/X ATT. [dB]	FREQUENCY	SINX/X ATT. [dB]
Low pass	Low pass	$0 \dots 0.4F_{data}$	$0 \dots 0.14$	$3.6 \dots 4F_{data}$	$19.2 \dots \infty$
Low pass	High pass	$1.6 \dots 2F_{data}$	$2.42 \dots 3.92$	$2 \dots 2.4F_{data}$	$3.92 \dots 5.94$
High pass	Low pass	$0.6 \dots 0.8F_{data}$	$0.32 \dots 0.58$	$3.2 \dots 3.4F_{data}$	$12.6 \dots 15.4$
High pass	High pass	$1.2 \dots 1.4F_{data}$	$1.33 \dots 1.83$	$2.6 \dots 2.8F_{data}$	$7.20 \dots 8.69$

**Table 2. Interpolation Filters Configuration: Example Frequencies GSM**

FILTER 1 CONFIGURATION	FILTER 2 CONFIGURATION	IF OUTPUT RANGE 1 (FIRST NYQUIST ZONE)		IF OUTPUT RANGE 2 (SECOND NYQUIST ZONE)	
		IF FREQUENCY [MHz]		IF FREQUENCY [MHz]	
		$F_{data} = 52$ MSPS	$F_{data} = 78$ MSPS	$F_{data} = 52$ MSPS	$F_{data} = 78$ MSPS
Low pass	Low pass	$0 \dots 20.8$	$0 \dots 31.2$	$187.2 \dots 208$	$280.8 \dots 312$
Low pass	High pass	$83.2 \dots 108$	$124.8 \dots 156$	$104 \dots 124.8$	$156 \dots 187.2$
High pass	Low pass	$31.2 \dots 41.6$	$46.8 \dots 62.4$	$166.4 \dots 176.8$	$249.6 \dots 265.2$
High pass	High pass	$62.4 \dots 72.8$	$93.6 \dots 109.2$	$135.2 \dots 145.6$	$202.8 \dots 218.4$

**Table 3. Interpolation Filters Configuration: Example Frequencies W-CDMA, IF =  $F_{data}/4$ ,  $F_{DATA} = 61.44$  MSPS;  $F_{update} = 245.76$  MSPS**

FILTER 1 CONFIGURATION	FILTER 2 CONFIGURATION	IF FREQUENCY [MHz] (FIRST NYQUIST ZONE)		IF FREQUENCY [MHz] (SECOND NYQUIST ZONE)	
		IF CENTER [MHz]	SINX/X ATT. [dB]	IF CENTER [MHz]	SINX/X ATT. [dB]
Low pass	Low pass	15.36	0.05	230.4	23.6
Low pass	High pass	107.52	2.93	138.24	5.11
High pass	Low pass	46.08	0.51	199.68	13.2
High pass	High pass	76.8	1.44	168.96	8.29

### Low-Pass/Low-Pass 4× Interpolation Filter Operation

Figure 16 shows the low-pass/low-pass interpolation operation where the 4× FIR filter is implemented as a cascade of two 2× interpolation filters with the input signal coming from a digital signal source such as an FPGA or digital upconverter (DUC). Users can place their IF signal at a maximum of 0.4 times the FIR filter input (i.e., DAC5674 input) data rate. For a 100-MSPS data rate, this would translate into a pass band extending to 40 MHz.

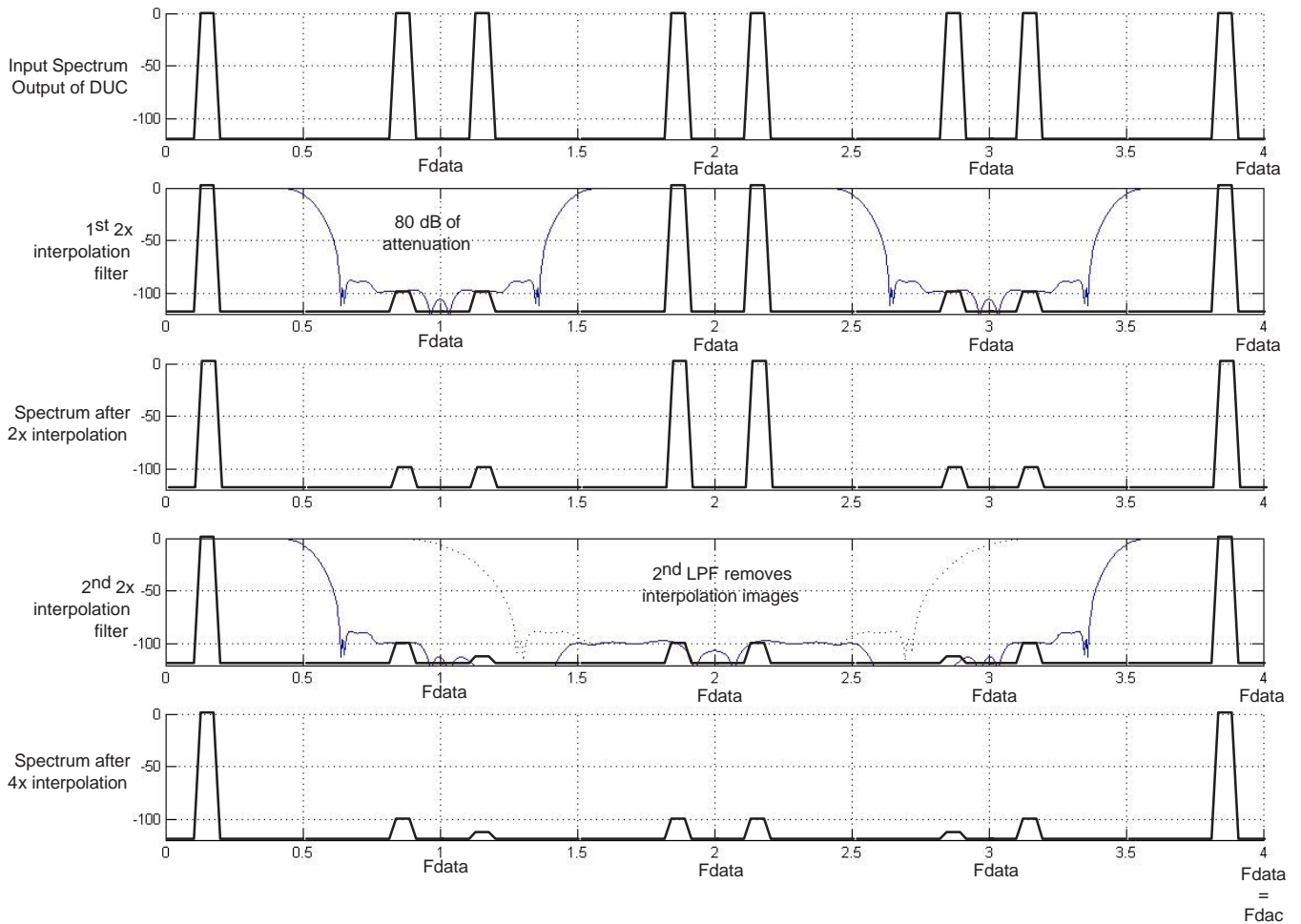

**Figure 16. Low-Pass/Low-Pass 4× Interpolation Filter Operation**

# DAC5674

SLWS148A – SEPTEMBER 2003 – REVISED OCTOBER 2005

## Low-Pass/High-Pass 4× Interpolation Filter Operation

By configuring the low-pass filters as high-pass filters, the user can select one of the images present at multiples of the clock. Figure 17 shows the low-pass/high-pass filter response. After digital filtering, the DAC transmits at  $2F_{data} - IF$  and  $2F_{data} + IF$ . This configuration is equivalent to sub-sampling receiver systems where a high-speed analog-to-digital converter samples high IF frequencies with relatively low sample rates, resulting in low (output) data rates.

The placement of the IF in the first Nyquist zone combined with the DAC5674 input data determines the final output signal frequency. For  $F_{data} = 100$  MSPS and a fundamental IF of  $0.4 \times F_{data} = 40$  MHz, this would translate into images located at 160 MHz and 240 MHz. Note that this is the equivalent of mixing a 40-MHz analog IF signal with a 200-MHz sine wave. By doing this, the first mixer in the total transmission chain is eliminated.

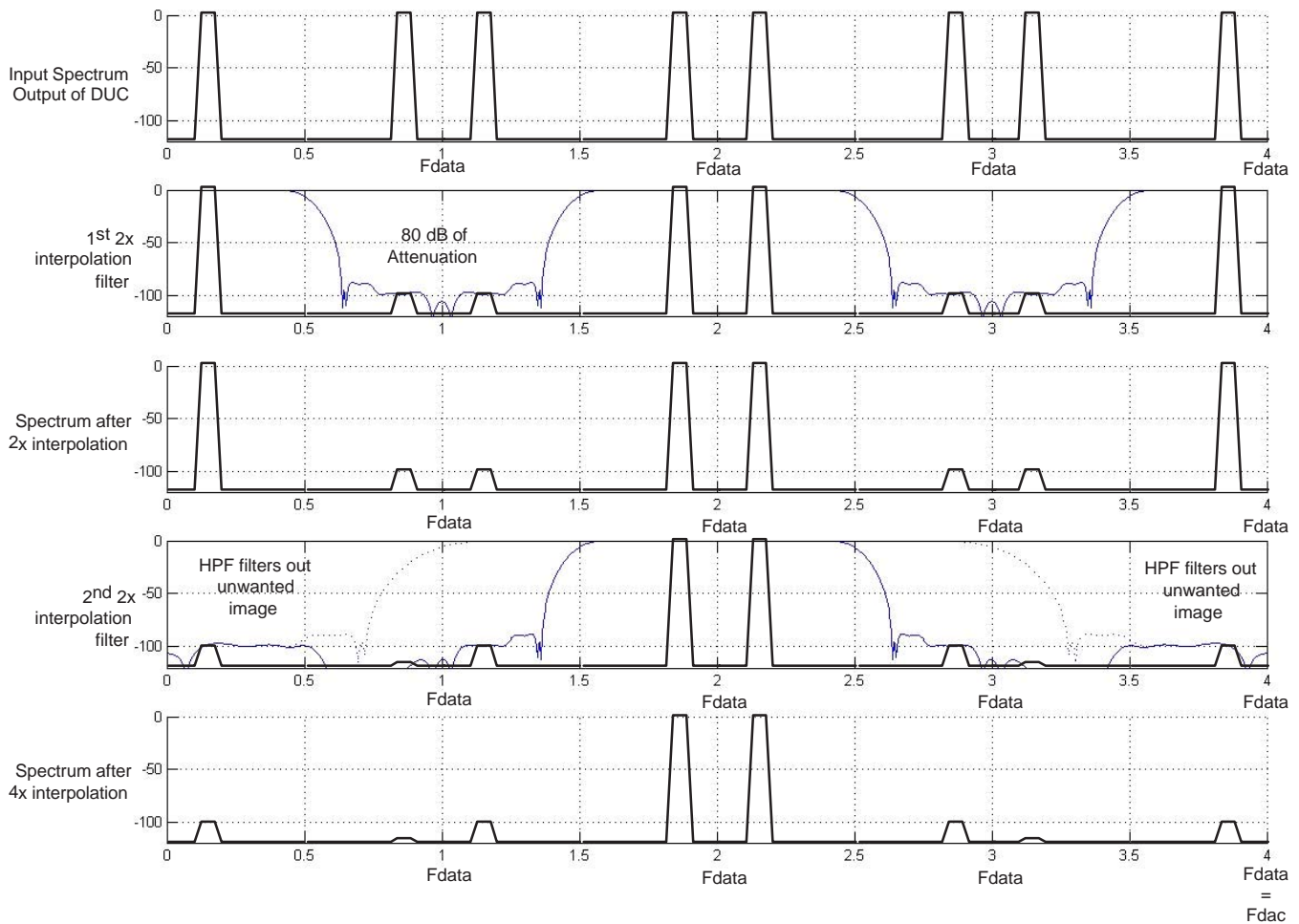
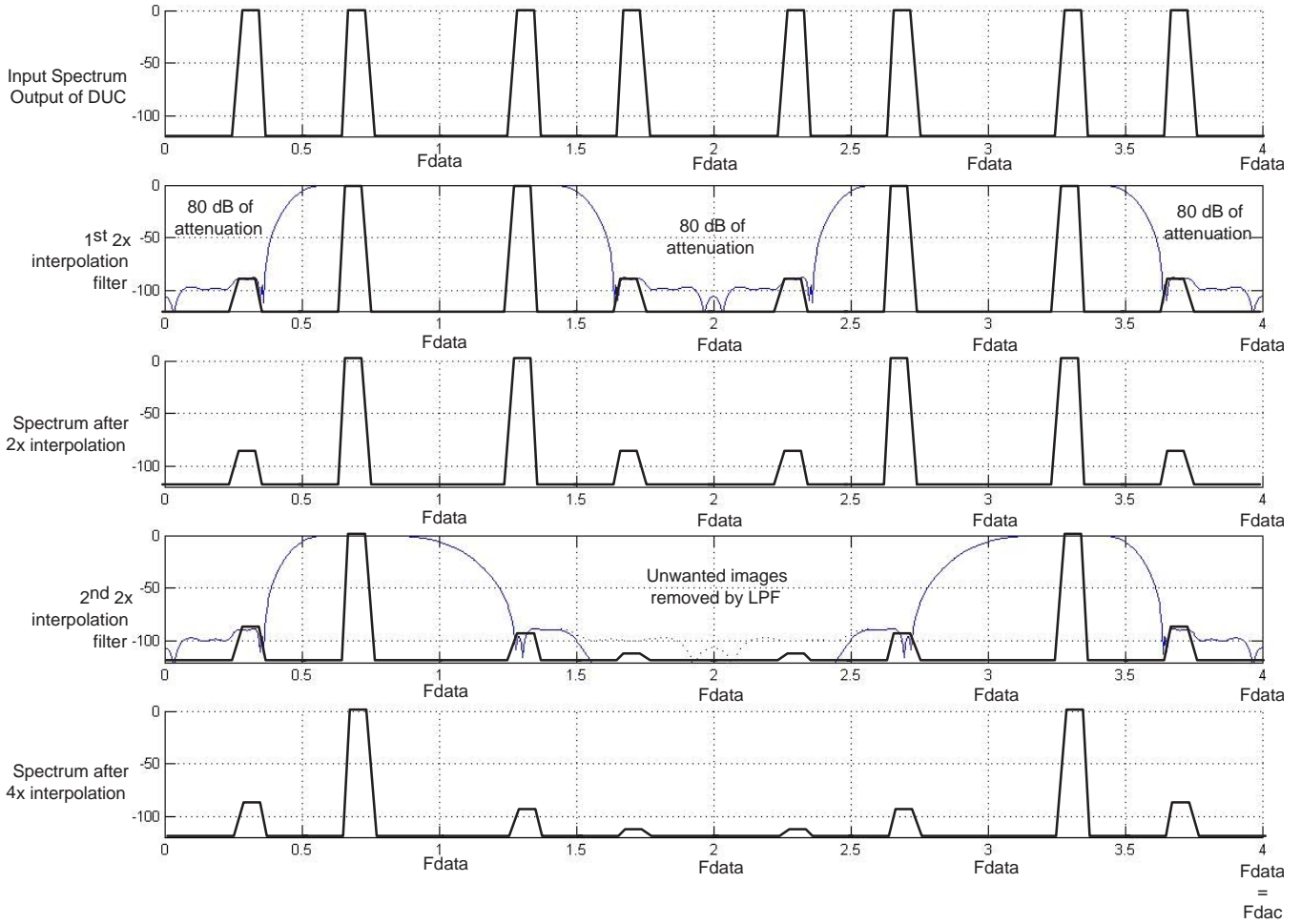

Figure 17. Low-Pass/High-Pass 4× Interpolation Filter Operation

**High-Pass/Low-Pass 4× Interpolation Filter Operation**

Figure 18 shows the high-pass/low-pass filter configuration. Images at  $F_{data} - IF$  and  $3F_{data} + IF$  can be selected. Note that the latter image severely attenuates by the  $\text{sinc}/x$  response. The transition bandwidths of filter 1 and filter 2 occupy  $0.2F_{data}$ . The combination of these transition bands results in an output IF between  $0.6 \dots 0.8F_{data}$ .



**Figure 18. High-Pass/Low-Pass 4× Interpolation Filter Operation**

### High-Pass/High-Pass 4× Interpolation Filter Operation

Figure 19 shows the high-pass/high-pass filter configuration. The transition bands of filter 1 and filter 2 allow for the placement of the fundamental IF between  $0.2...0.4F_{data}$ . In this configuration, the user can select the images at  $F_{data} + IF$  and  $3F_{data} - IF$ . For  $F_{data} = 100$  MSPS and a fundamental IF of  $0.4 \times F_{data} = 40$  MHz, this would translate into images located at 140 MHz and 260 MHz. Note that this is the equivalent of mixing a 60-MHz analog IF signal with a 200-MHz sine wave.

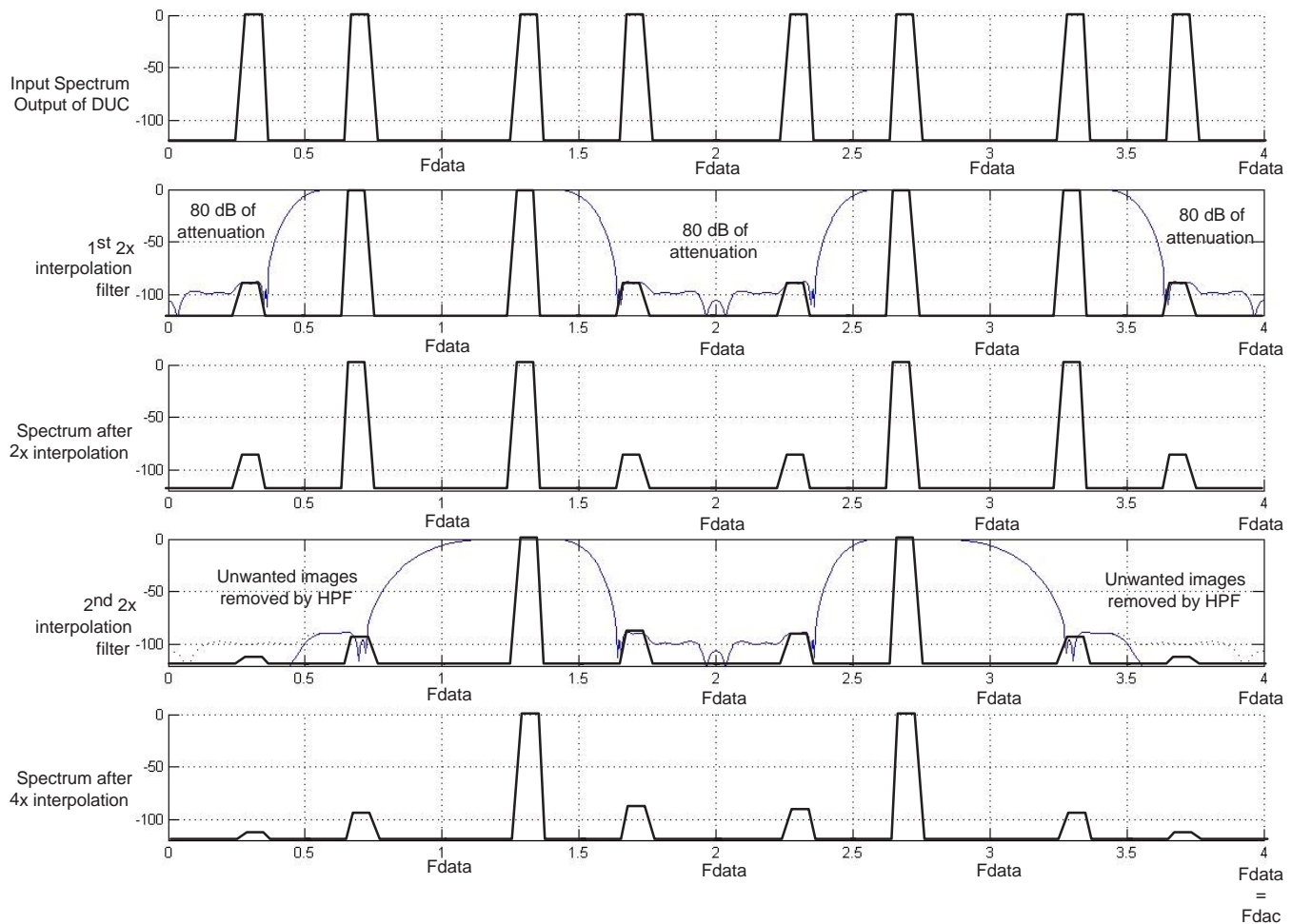
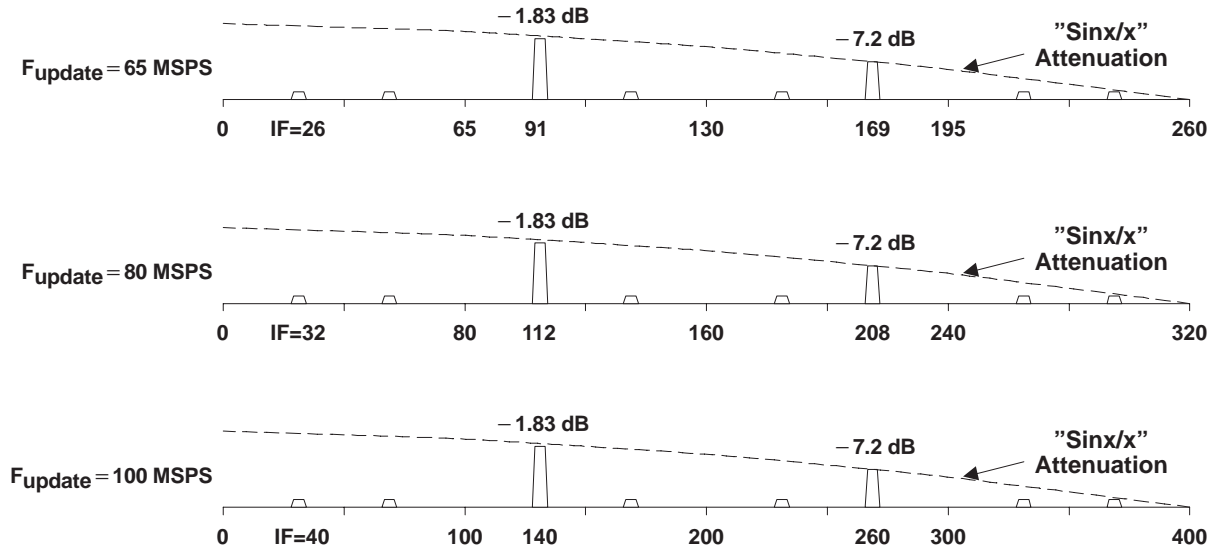

**Figure 19. High-Pass/High-Pass 4× Interpolation Filter Operation**

### DAC Sinx/x Output Attenuation

The output frequency spectrum of the DACs shows some inherent attenuation due to their sample-and-hold nature. The output of the DAC is normally seen as the signal sample held over the sampling time in a stair-step manner. In the time domain, this step-like output can be thought of as an impulse sample of some value convolved with a unit-square pulse with a duration of the sampling time. In the frequency domain, this translates to the frequency response of the discretely sampled signal multiplied by the  $\text{sinc}/x$  frequency response function of the square pulse. The  $\text{sinc}/x$  function has a null at every integer multiple of the sampling rate.

This is shown in Figure 20 for various data rates at 4× interpolation.



**Figure 20. High-Pass 4× Interpolation Filter Operation: Example Frequencies**

### Clock Generation Function

An internal phase-locked loop (PLL) or external clock can be used to derive the internal clocks (1×, 2×, and 4×) for the logic, FIR interpolation filters, and DAC. Basic functionality is depicted in Figure 21. Power for the internal PLL blocks (PLL<sub>VDD</sub> and PLL<sub>GND</sub>) is separate from the other clock generation blocks power (CLK<sub>VDD</sub> and CLK<sub>GND</sub>), thus minimizing phase noise within the PLL. The PLL<sub>VDD</sub> pin establishes internal/external clock mode: when PLL<sub>VDD</sub> is grounded, external clock mode is active and when PLL<sub>VDD</sub> is 3.3 V, internal clock mode is active.

In external clock mode, the user provides a differential external clock on pins CLK/CLKC. This clock becomes the 4× clock and is twice divided down to generate the 2× and 1× clocks. The 2× or 1× clock is multiplexed out on the PLL<sub>LOCK</sub> pin to allow for external clock synchronization.

In internal clock mode, the user provides a differential external reference clock on CLK/CLKC. A type four phase-frequency detector (PFD) in the internal PLL compares this reference clock to a feedback clock and drives the PLL to maintain synchronization between the two clocks. The feedback clock is generated by dividing the VCO output by 1×, 2×, 4×, or 8×, as selected by the prescaler (DIV[1:0]). The output of the prescaler is the 4× clock, and is divided down twice to generate the 2× and 1× clocks. Pin X4 selects the 1× or 2× clock to clock in the input data; the selected clock is also fed back to the PFD for synchronization. The PLL<sub>LOCK</sub> pin is an output indicating when the PLL has achieved lock. An external RC low-pass PLL filter is provided by the user at pin LPF. See the *Low-Pass Filter* section for filter setting calculations. Table 4 provides a summary of the clock configurations with corresponding data rate ranges.

# DAC5674

SLWS148A – SEPTEMBER 2003 – REVISED OCTOBER 2005

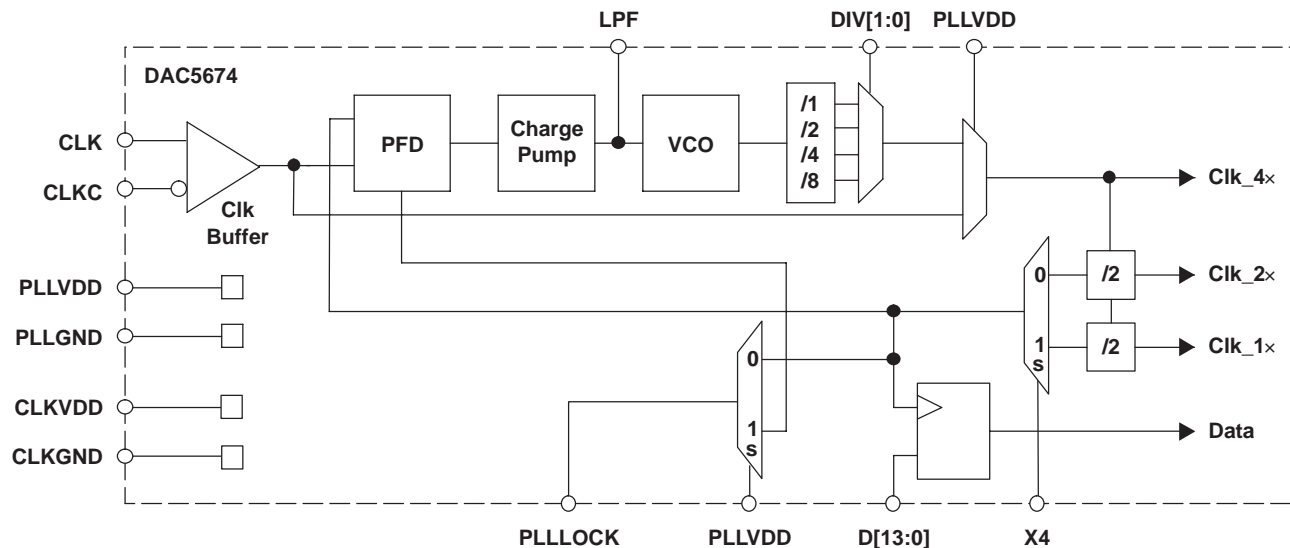

Figure 21. Clock Generation Functional Diagram

Table 4. Clock Mode Configuration

CLOCK MODE	PLLVDD	DIV[1:0]	X4	DATA RANGE (MHz)	PLLLOCK PIN FUNCTION
External 2×	0 V	XX	0	DC to 200	External clock/2
External 4×	0 V	XX	1	DC to 100	External clock/4
Internal 2×	3.3 V	00	0	100 to 200	Internal PLL lock indicator
Internal 2×	3.3 V	01	0	50 to 100	Internal PLL lock indicator
Internal 2×	3.3 V	10	0	25 to 50	Internal PLL lock indicator
Internal 2×	3.3 V	11	0	12 to 25	Internal PLL lock indicator
Internal 4×	3.3 V	00	1	50 to 100	Internal PLL lock indicator
Internal 4×	3.3 V	01	1	25 to 50	Internal PLL lock indicator
Internal 4×	3.3 V	10	1	12 to 25	Internal PLL lock indicator
Internal 4×	3.3 V	11	1	5 to 12	Internal PLL lock indicator

## Low-Pass Filter

The PLL consists of a type four phase-frequency detector (PFD), charge pump, external low-pass loop filter, voltage to current converter, and current controlled oscillator (ICO) as shown in Figure 22. The DAC5674 evaluation board comes with component values  $R = 200$ ,  $C_1 = 0.01 \mu\text{F}$ , and  $C_2 = 100 \text{ pF}$ . These values have been designed to give the phase margins and loop bandwidths listed in Table 5 for the five divide down factors of prescaling and interpolation. Note that the values derived were based on a charge pump current output of 1 mA and a VCO gain of 300 MHz/V (nominal at  $F_{\text{vco}} = 400 \text{ MHz}$ ). With this filter, the settling time from a phase or frequency disturbance is about  $2.5 \mu\text{s}$ . If different PLL dynamics are required, DAC5674 users can design a second order filter for their application; see the *Designing the PLL Loop Filter* section of this data sheet.

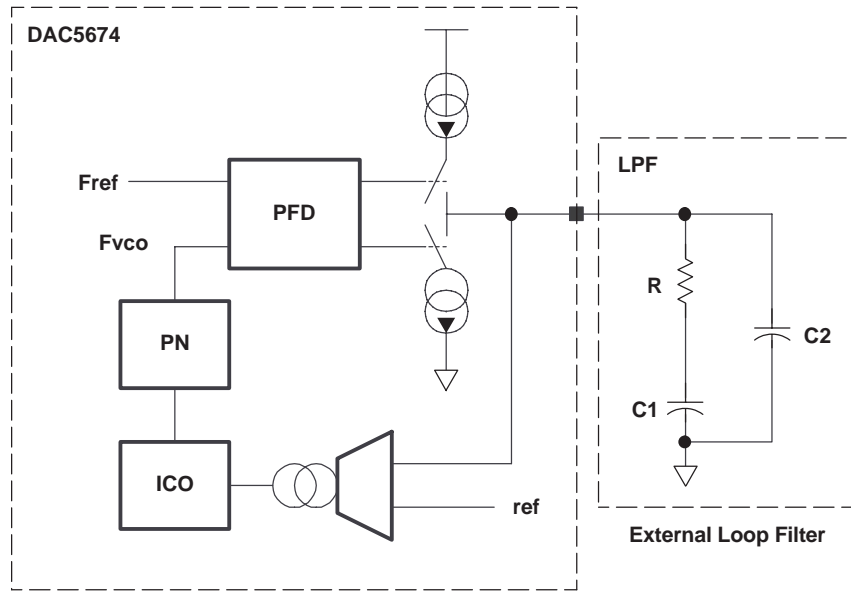

Figure 22. PLL Functional Block Diagram

Table 5. DAC5674 Evaluation Board PLL Loop Filter Parameters

N(1)	PHASE MARGIN (DEGREES)	BANDWIDTH (MHZ)
2	60	1.6
4	71	1.4
8	77	1
16	78	0.7
32	74	0.4

(1) N is the VCO divide-down factor from prescale and interpolation.

### Non-Harmonic Clock-Related Spurious Signals

In interpolating DACs, imperfect isolation between the digital and DAC clock circuits generates spurious signals at frequencies related to the DAC clock rate. The digital interpolation filters in these DACs run at subharmonic frequencies of the output rate clock, where these frequencies are  $f_{DAC}/2$ ,  $N = 1, 2$ . For example, for  $2\times$  interpolation only one interpolation filter runs at  $f_{DAC}/2$ ; for  $4\times$  interpolation, on the other hand, two interpolation filters run at  $f_{DAC}/2$  and  $f_{DAC}/4$ . These lower-speed clocks for the interpolation filter mix with the DAC clock circuit and create spurious images of the wanted signal and second Nyquist-zone image at offsets of  $f_{DAC}/2^N$ .

Figure 23 shows the location of the largest spurious signals for  $4\times$  interpolation for a real signal. With a real output signal, there is no distinction between negative and positive frequencies, and therefore the signals that appear at negative frequencies wrap and potentially fall near the wanted signal. In particular, at IFs near  $f_{DAC}/8$ ,  $f_{DAC}/4$ , and  $f_{DAC} \times 3/4$  (50 MHz, 100 MHz, and 150 MHz in this example), the mixing effect results in spurious signals falling near the wanted signal, which may present a problem depending on the system application. For a frequency-symmetric signal (such as a single WCDMA or CDMA carrier), operating at exactly  $f_{DAC}/8$ ,  $f_{DAC}/4$  and  $f_{DAC} \times 3/4$ , the spurious signal falls completely inside the wanted signal, which produces a clean spectrum but may result in degradation of the signal quality.

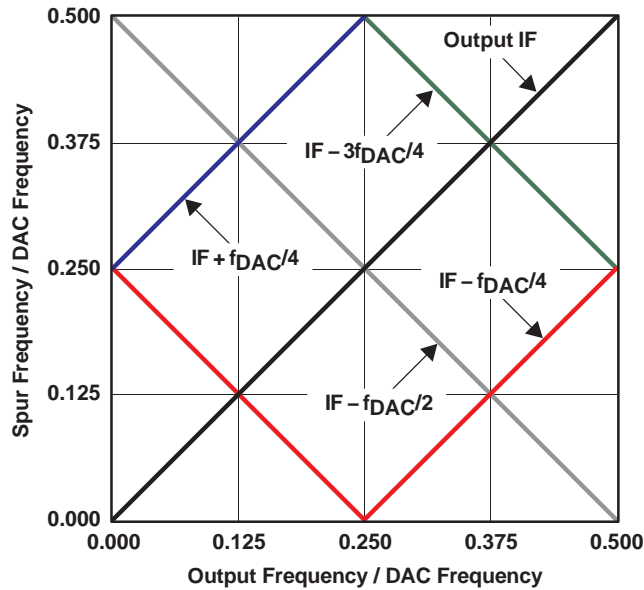

Figure 23. Location of Clock Mixing Spurs vs IF for 4x Mode

The offset between wanted and spurious signals is maximized at low IFs ( $< f_{DAC}/8$ ) and at  $f_{DAC} \times 3/16$ ,  $f_{DAC} \times 5/16$ , and  $f_{DAC} \times 7/16$ . For example, with  $f_{DATA} = 100$  MSPS and 4x interpolation, operating with  $IF = f_{DAC} \times 5/16 = 125$  MHz results in spurious signals at offsets of  $\pm 50$  MHz from the wanted signal.

Figure 24a shows the amplitude of each spurious signal as a function of IF in external-clock mode. The dominant spurious signal is  $IF - f_{DAC}/2$ . The amplitudes of the  $IF + f_{DAC}/4$  and  $IF - f_{DAC}/4$  are the next-highest spurious signals and are approximately at the same amplitude. Finally, at IF frequencies greater than 100 MHz, small spurious signals at  $IF - f_{DAC} \times 3/4$  are measurable.

Figure 24b shows the amplitude of each spurious signal as a function of IF in PLL clock mode. Generating the DAC clock with the onboard PLL/VCO increases the  $IF - f_{DAC}/2$  by 3 dB. The amplitude of the  $IF \pm f_{DAC}/4$  and  $IF - f_{DAC} \times 3/4$  remain at about the same level as in the external-clock mode.

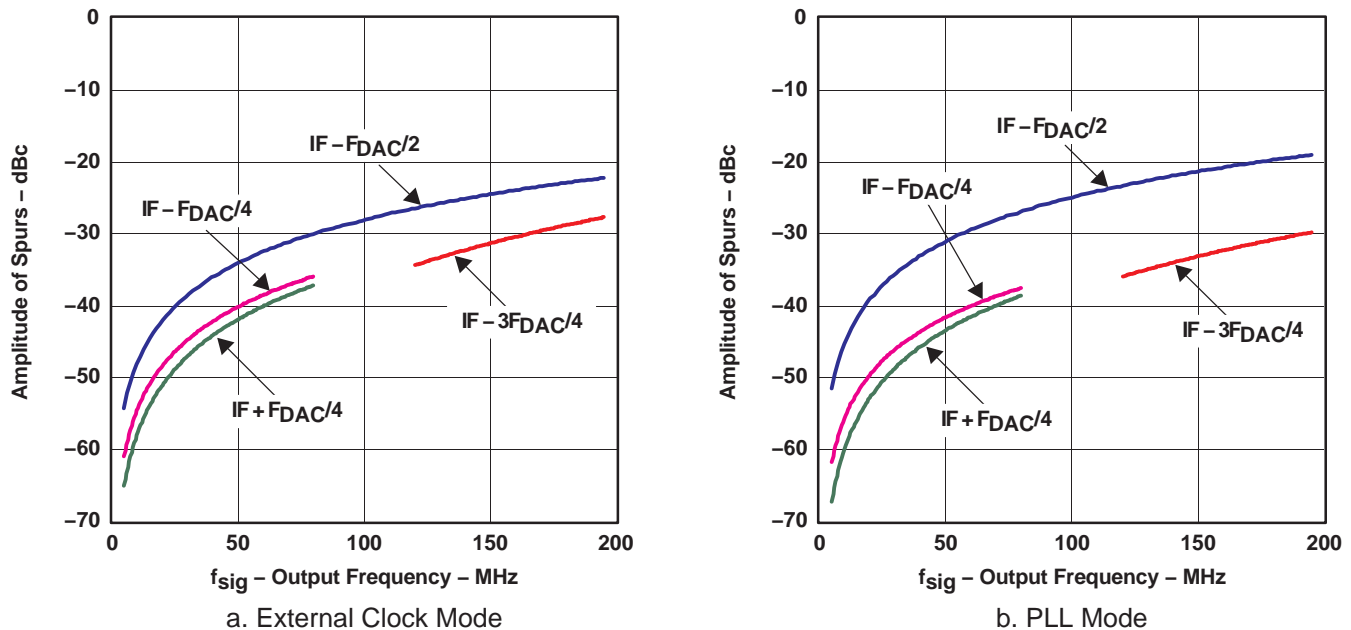

Figure 24. External Clock Mode and PLL Mode

The amplitudes in Figure 24 are typical values and vary by a few dB across different parts, supply voltages, and temperatures. Figure 23 and Figure 24 can be used to estimate the non-harmonic clock-related spurious signals. Take the example for using the DAC5674 in external-clock mode,  $f_{DAC} = 400$  MHz, 4× interpolation, and  $IF = 30$  MHz. Figure 23 and Figure 24a predict the spurious signals shown in Table 6. The resulting spurs are at 170 MHz at  $-38$  dBc, 130 MHz at  $-45$  dBc, and 70 MHz at  $-43$  dBc.

**Table 6. Predicted Frequency and Amplitude for  $F_{DAC} = 400$  MHz, 4× Interpolation**

SPURIOUS COMPONENT	SPURIOUS FREQUENCY	AMPLITUDE dBc
$IF - f_{DAC}/2$	170 MHz	$-38$
$IF + f_{DAC}/4$	130 MHz	$-45$
$IF - f_{DAC}/4$	70 MHz	$-43$
$IF - 3f_{DAC}/4$	$>200$ MHz	N/A

Figure 25 shows the DAC5674 output spectrum for the preceding example. The amplitudes of the clock-related spurs agree quite well with the predicted amplitudes in Table 6.

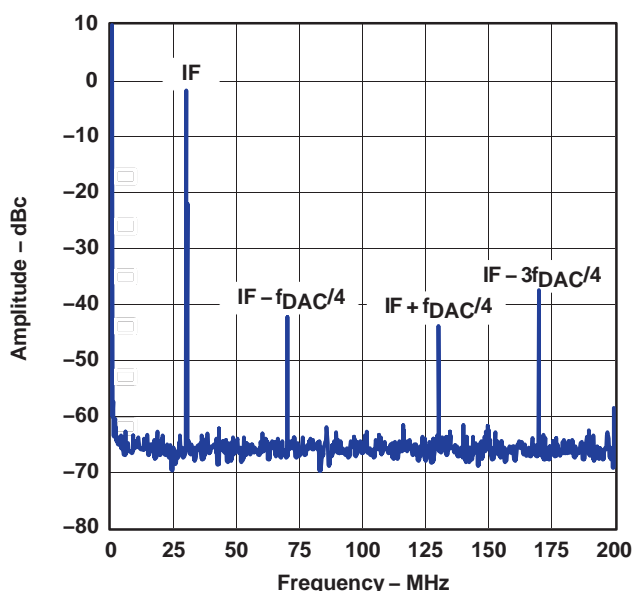

**Figure 25. DAC Output Spectrum With  $F_{DAC} = 400$  MSPS, 4× Interpolation,  $IF=30$  MHz, External Clock**

### Digital Inputs

Figure 26 shows a schematic of the equivalent CMOS digital inputs of the DAC5674. The CMOS-compatible inputs have logic thresholds of  $IOVDD/2 \pm 20\%$ . The 14-bit digital data input follows the offset positive binary coding scheme.

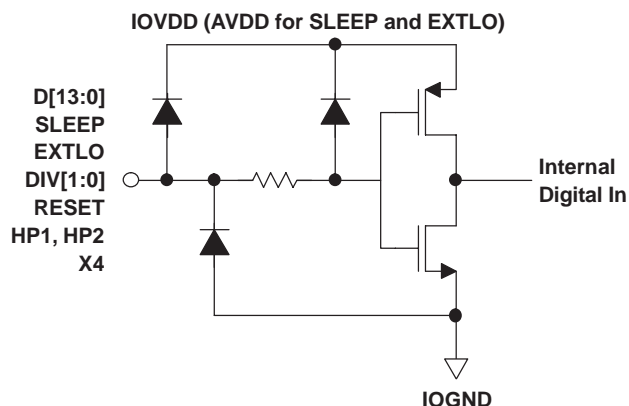

**Figure 26. CMOS/TTL Digital Equivalent Input**

# DAC5674

SLWS148A – SEPTEMBER 2003 – REVISED OCTOBER 2005

## Clock Input and Timing

Figure 27 shows the clock and data input timing diagram for internal and external clock modes, respectively. Note that a negative value indicates a reversal of the edge positions as shown in the timing diagram. Figure 27 also shows the delay ( $t_d$ ) of the  $1\times/2\times$  data clock (PLLLOCK) from CLK in external clock mode (typical  $t_d = 4.1$  ns). The latency from data to DAC is defined by Figure 28. The DAC5674 features a differential clock input. In internal clock mode, the internal data clock is a divided down version of the PLL clock ( $/2$  or  $/4$ ), depending on the level of interpolation ( $2\times$  or  $4\times$ ). In external mode, the internal data clock is a divided down version of the input CLK ( $/2$  or  $/4$ ), depending on the level of interpolation ( $2\times$  or  $4\times$ ). Internal edge-triggered flip-flops latch the input word on the rising edge of the positive data clock.

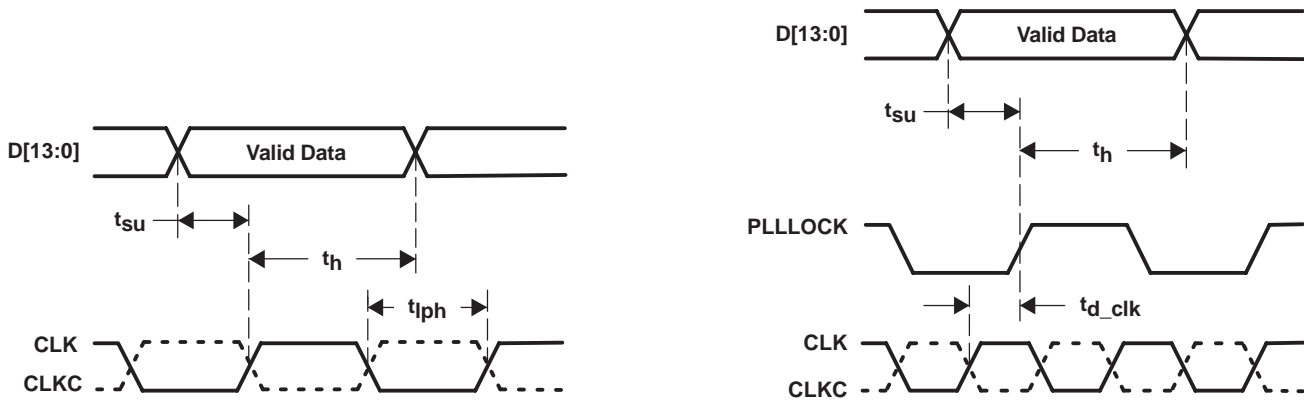

Figure 27. Internal (Left) and External (Right) Clock Mode Timing

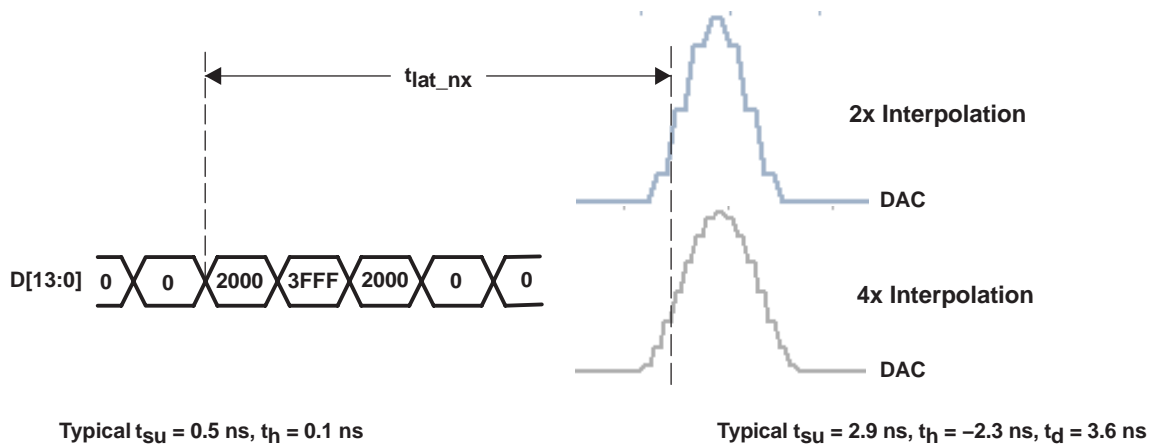

Figure 28. Data to DAC Latency

Figure 29 shows an equivalent circuit for the clock input.

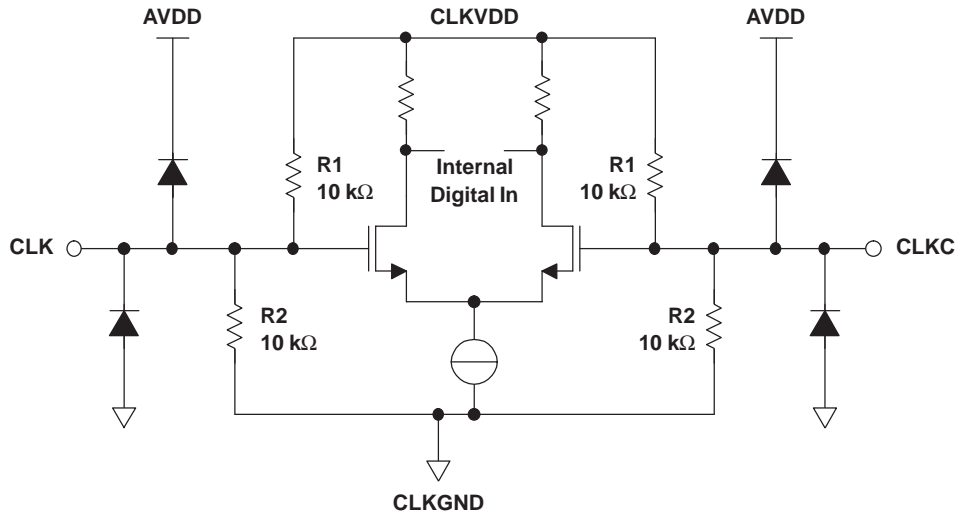

Figure 29. Clock Input Equivalent Circuit

Figure 30, Figure 31, Figure 32, and Figure 33 show various input configurations for driving the differential clock input (CLK/CLKC).

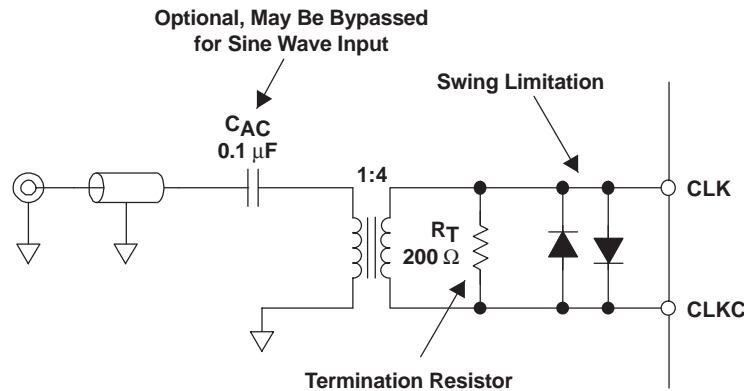

Figure 30. Preferred Clock Input Configuration

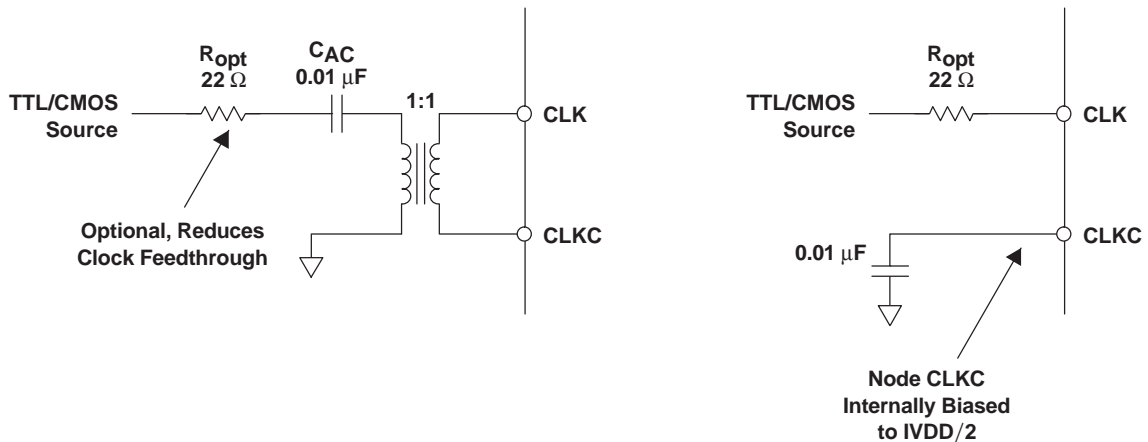
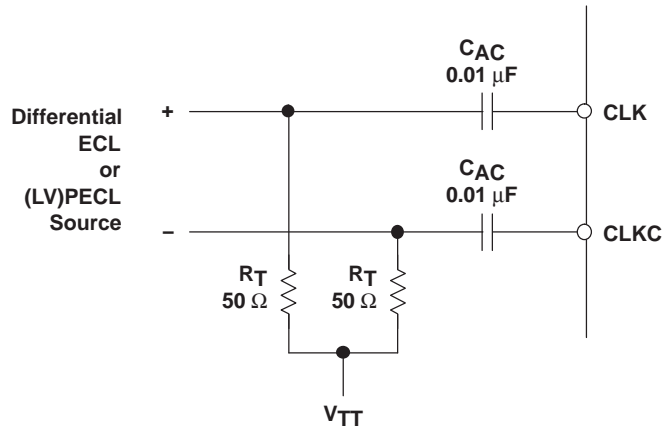

Figure 31. Driving the DAC5674 With a Single-Ended TTL/CMOS Clock Source

# DAC5674

SLWS148A – SEPTEMBER 2003 – REVISED OCTOBER 2005



**Figure 32. Driving the DAC5674 With Differential ECL/PECL Clock Source**

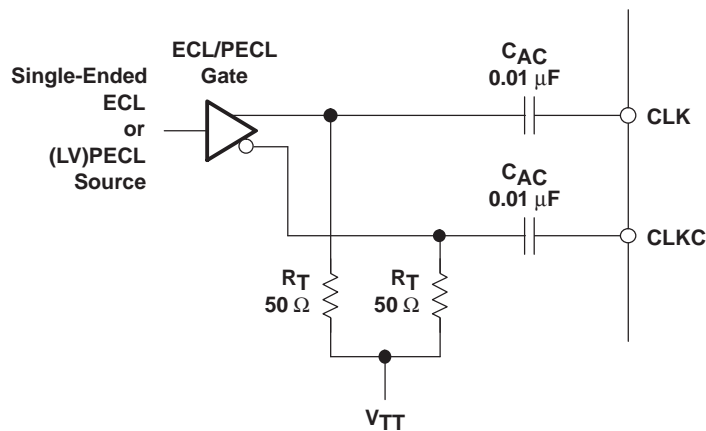

**Figure 33. Driving the DAC5674 With a Single-Ended ECL/PECL Clock Source**

## Supply Inputs

The DAC5674 comprises separate analog and digital supplies at AVDD, DVDD, and IOVDD. These supplies can range from 3 V to 3.6 V for AVDD, 1.65 to 1.95 V for DVDD, and 1.65 to 3.6 for IOVDD.

## DAC Transfer Function

The DAC5674 delivers complementary output currents IOUT1 and IOUT2. The DAC supports straight binary coding, with D13 being the MSB and D0 the LSB. Output current IOUT1 equals the approximate full-scale output current when all input bits are set high, i.e., the binary input word has the decimal representation 16383. Full-scale output current flows through terminal IOUT2 when all input bits are set low (mode 0, straight binary input). The relation between IOUT1 and IOUT2 can thus be expressed as:

$$I_{OUT1} = \frac{2^N - 1}{2^N} I_{OUT_{FS}} - I_{OUT2}$$

Where  $I_{OUT_{FS}}$  is the full-scale output current,  $N = 14$  bits. The output currents can be expressed as:

$$I_{OUT1} = I_{OUT_{FS}} \times \frac{CODE}{16384}$$

$$I_{OUT2} = I_{OUT_{FS}} \times \frac{16383 - CODE}{16384}$$

Where CODE is the decimal representation of the DAC data input word. Output currents IOUT1 and IOUT2 drive resistor loads ( $R_L$ ) or a transformer with equivalent input load resistance ( $R_L$ ). This would translate into single-ended voltages VOUT1 and VOUT2 at terminal IOUT1 and IOUT2, respectively, of:

$$VOUT1 = IOUT1 \times R_L = IOUT_{FS} \times \frac{CODE}{16384} \times R_L$$

$$VOUT2 = IOUT2 \times R_L = IOUT_{FS} \times \frac{16383 - CODE}{16384} \times R_L$$

The differential output voltage  $VOUT_{DIFF}$  can thus be expressed as:

$$VOUT_{DIFF} = VOUT1 - VOUT2 = IOUT_{FS} \times \frac{2CODE - 16383}{16384} \times R_L$$

The latter equation shows that applying the differential output results in doubling of the signal power delivered to the load. Because the output currents  $IOUT1$  and  $IOUT2$  are complementary, they become additive when processed differentially. Note that care should be taken not to exceed the compliance voltages at node  $IOUT1$  and  $IOUT2$ , which would lead to increased signal distortion.

### Reference Operation

The DAC5674 comprises a band-gap reference and control amplifier for biasing the full-scale output current. The full-scale output current is set by applying an external resistor  $R_{BIAS}$ . The bias current  $I_{BIAS}$  through resistor  $R_{BIAS}$  is defined by the on-chip band-gap reference voltage and control amplifier. The full-scale output current equals 32 times this bias current. The full-scale output current  $IOUT_{FS}$  can thus be expressed as:

$$IOUT_{FS} = 32 \times I_{BIAS} = \frac{32 \times V_{EXTIO}}{R_{BIAS}}$$

where  $V_{EXTIO}$  is the voltage at terminal  $EXTIO$ . The band-gap reference voltage delivers an accurate voltage of 1.2 V. This reference is active when terminal  $EXTLO$  is connected to  $AGND$ . An external decoupling capacitor  $C_{EXT}$  of 0.1  $\mu F$  should be connected externally to terminal  $EXTIO$  for compensation. The band-gap reference can additionally be used for external reference operation. In that case, an external buffer with high impedance input should be applied in order to limit the band-gap load current to a maximum of 100 nA. The internal reference can be disabled and overridden by an external reference by connecting  $EXTLO$  to  $AVDD$ . In this case, capacitor  $C_{EXT}$  can be omitted. Terminal  $EXTIO$  serves as either input or output node.

The full-scale output current can be adjusted from 20 mA to 2 mA by varying resistor  $R_{BIAS}$  or changing the externally applied reference voltage. The internal control amplifier has a wide input range, supporting the full-scale output current range of 20 mA.

### Analog Current Outputs

Figure 34 shows a simplified schematic of the current source array output with corresponding switches. Differential switches direct the current of each individual PMOS current source to either the positive output node  $IOUT1$  or its complementary negative output node  $IOUT2$ . The output impedance is determined by the stack of the current sources and differential switches, and is typically  $>300 \text{ k}\Omega$  in parallel with an output capacitance of 5 pF.

The external output resistors are referred to an external ground. The minimum output compliance at nodes  $IOUT1$  and  $IOUT2$  is limited to  $-1 \text{ V}$ , determined by the CMOS process. Beyond this value, transistor breakdown may occur resulting in reduced reliability of the DAC5674 device. The maximum output compliance voltage at nodes  $IOUT1$  and  $IOUT2$  equals 1.25 V. Exceeding the maximum output compliance voltage adversely affects distortion performance and integral nonlinearity. The optimum distortion performance for a single-ended or differential output is achieved when the maximum full-scale signal at  $IOUT1$  and  $IOUT2$  does not exceed 0.5 V.

# DAC5674

SLWS148A – SEPTEMBER 2003 – REVISED OCTOBER 2005

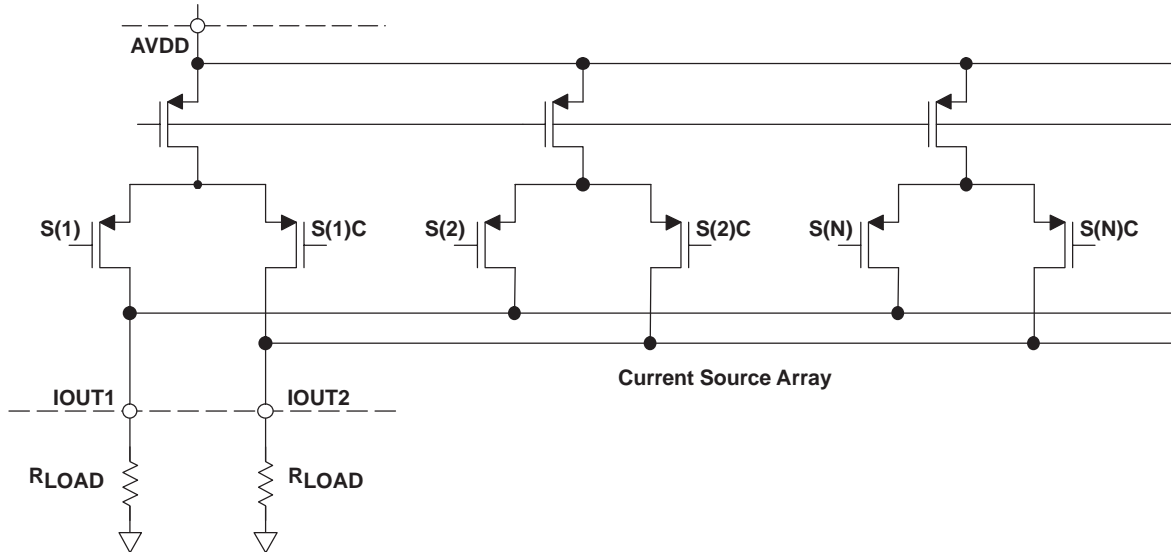

**Figure 34. Equivalent Analog Current Output**

The DAC5674 can be easily configured to drive a doubly terminated 50-Ω cable using a properly selected RF transformer. Figure 35 and Figure 36 show the 50-Ω doubly terminated transformer configuration with 1:1 and 4:1 impedance ratio, respectively. Note that the center tap of the primary input of the transformer has to be grounded to enable a dc current flow. Applying a 20-mA full-scale output current would lead to a 0.5 V<sub>PP</sub> for a 1:1 transformer and a 1 V<sub>PP</sub> output for a 4:1 transformer.

Figure 37 shows the single-ended output configuration, where the output current IOUT1 flows into an equivalent load resistance of 25 Ω. Node IOUT2 should be connected to AGND or terminated with a resistor of 25 Ω to AGND. The nominal resistor load of 25 Ω gives a differential output swing of 1 V<sub>PP</sub> when applying a 20-mA full-scale output current.

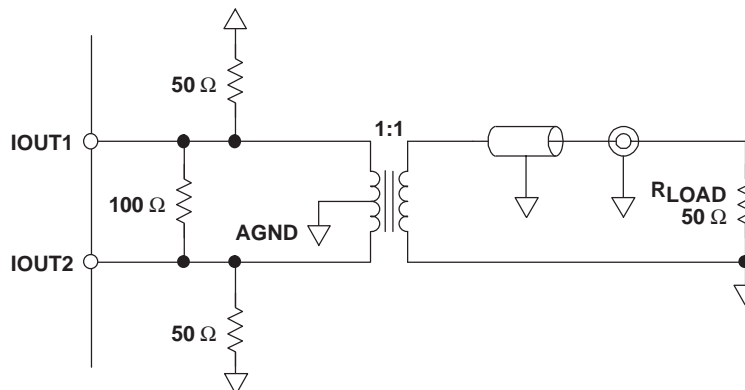

**Figure 35. Driving a Doubly Terminated 50-Ω Cable Using a 1:1 Impedance Ratio Transformer**

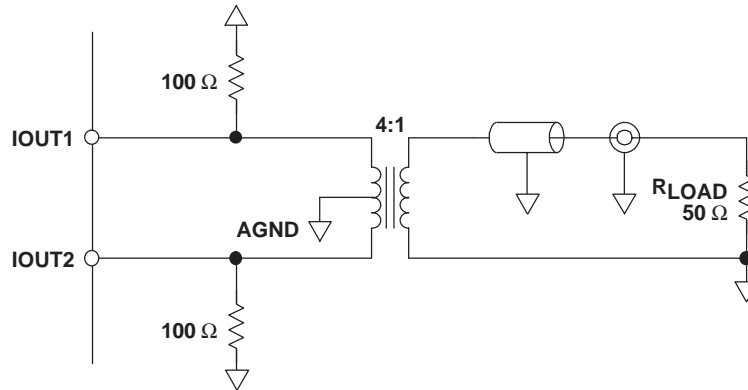

**Figure 36. Driving a Doubly Terminated 50-Ω Cable Using a 4:1 Impedance Ratio Transformer**

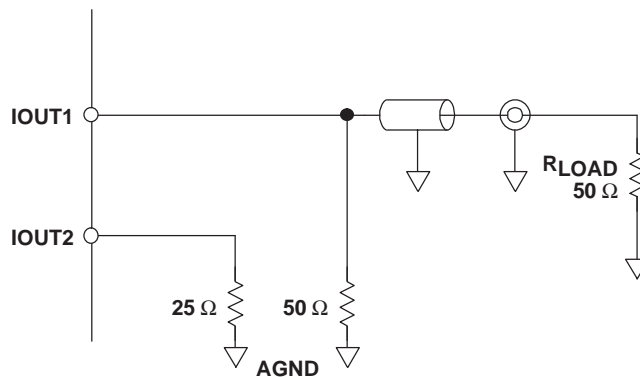

**Figure 37. Driving a Doubly Terminated 50-Ω Cable Using Single-Ended Output**

### Sleep Mode

The DAC5674 features a power-down mode that turns off the output current and reduces the supply current to less than 5 mA over the supply range of 3 V to 3.6 V and temperature range. The power-down mode is activated by applying a logic level 1 to the SLEEP pin (e.g., by connecting pin SLEEP to AVDD). An internal pulldown circuit at node SLEEP ensures that the DAC5674 is enabled if the input is left disconnected. Power-up and power-down activation times depend on the value of external capacitor at node EXTIO. For a nominal capacitor value of 0.1-μF power-down takes less than 5 μs, and power-up takes approximately 3 ms. With external reference, power up takes 10 μs; power down remains the same.

### DAC5674 Evaluation Board

A combo EVM board is available for the DAC5674 digital-to-analog converter for evaluation. This board allows the user the flexibility to operate the DAC5674 in various configurations. Possible output configurations include transformer coupled, resistor terminated, inverting/noninverting and differential amplifier outputs. The digital inputs are designed to interface with a TMS320 DSP SDK or to be driven directly from various pattern generators with the onboard option to add a resistor network for proper load termination. See the *DAC5674 EVM User's Guide* (SWRU007) for more information.

# DAC5674

SLWS148A – SEPTEMBER 2003 – REVISED OCTOBER 2005

## DESIGNING THE PLL LOOP FILTER

The DAC5674 contains an external loop filter to set the bandwidth and phase margin of the PLL. For the external second-order filter shown in Figure 38, the components R1, C1, and C2 are set by the user to optimize the PLL for the application. The resistance R3 = 200 Ω and the capacitance C3 = 8 pF are internal to the DAC5674. Note that R1 and C1 can be reversed.

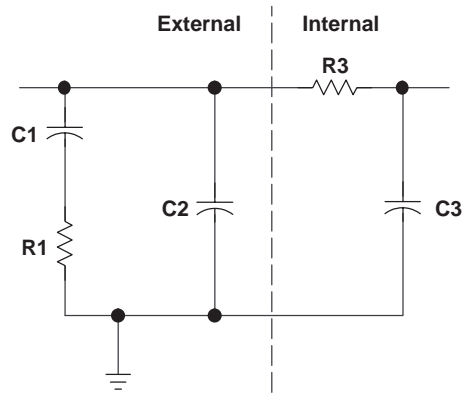

**Figure 38. DAC5674 Loop Filter**

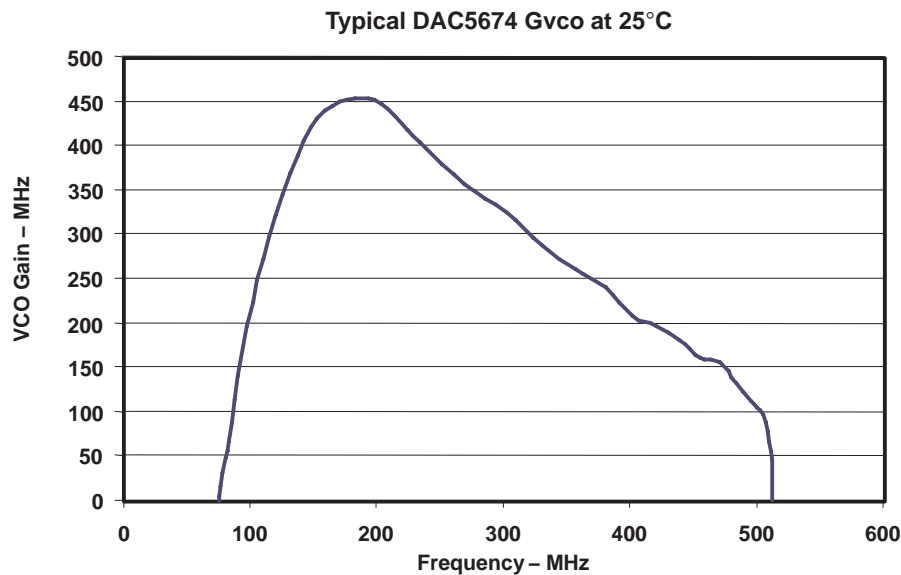

**Figure 39. Typical VCO Gain vs VCO Frequency at 25°C**

The typical VCO gain (G<sub>vco</sub>) (the slope of VCO frequency vs voltage) as a function of VCO frequency for the DAC5674 is shown in Figure 39. For the lowest possible phase noise, the VCO frequency should be chosen so G<sub>vco</sub> is minimized, where

$$F_{vco} = F_{data} \times \text{Interpolation} \times \text{PLL Divider:}$$

For example, if F<sub>data</sub> = 100 MSPS and 2× interpolation is used, the PLL divider should be set to 2 to lock the VCO at 400 MHz for a typical G<sub>vco</sub> of 210 MHz/V. Note that the maximum specified VCO frequency range is 160 MHz to 400 MHz.

The external loop filter components C1, C2, and R1 are given by choosing Gvco, N = Fvco/Fdata, the loop phase margin  $\phi_d$  and the loop bandwidth  $\omega_d$ . Except for applications where abrupt clock frequency changes require a fast PLL lock time, it is suggested that  $\phi_d$  be set to at least 80 degrees for stable locking and suppression of the phase noise side lobes. Phase margins of 60 degrees or less have occasionally been sensitive to board layout and decoupling details.

The optimum loop bandwidth  $\omega_d$  depends on both the VCO phase noise, which is largely a function of Gvco, and the application. For the foregoing example with Gvco = 210 MHz/V, an  $\omega_d = 1$  MHz would be typical, but lower and higher loop bandwidths may provide better phase-noise characteristics. For a higher Gvco, for example Gvco = 400 MHz/V, a  $\omega_d \approx 7$  MHz would be typical. However, it is suggested that the customer experiment with varying the loop bandwidth by at least 1/2× through 2× to verify the optimum setting.

C1, C2, and R1 are then calculated by the following equations:

$$C1 = \tau1 \left( 1 - \frac{\tau2}{\tau3} \right) \quad C2 = \frac{\tau1 - \tau2}{\tau3} \quad R1 = \frac{\tau3^2}{\tau1(\tau3 - \tau2)}$$

where

$$\tau1 = \frac{K_d K_{VCO}}{\omega_d^2} (\tan \phi_d + \sec \phi_d) \quad \tau2 = \frac{1}{\omega_d (\tan \phi_d + \sec \phi_d)} \quad \tau3 = \frac{\tan \phi_d + \sec \phi_d}{\omega_d}$$

and

charge pump current:	iqp = 1 mA
vco gain:	Kvco = 2π × Gvco rad/V
Fvco/Fdata:	N = {2, 4, 8, 16, 32}
phase detector gain:	Kd = iqp × (2πN) <sup>-1</sup> A/rad

An Excel™ spreadsheet is provided by TI for automatically calculating the values for C1, C2, and R.

Completing the preceding example with

PARAMETER	VALUE	UNIT
Gvco	2.10E+02	MHz/V
$\omega_d$	1.00E+00	MHz
N	4	
$\phi_d$	80	degrees

the component values are

C1 (F)	C2 (F)	R (Ω)
1.51E-08	1.16E-10	1.21E+02

As the PLL characteristics are not sensitive to these components, the closest 20% tolerance capacitor and 1% tolerance resistor values can be used. If the calculation results in a negative value for C2 or an unrealistically large value for C1, then the phase margin may need to be reduced slightly.

## USING PowerPAD DEVICES

A thermal land should be placed on the top and bottom layers of the circuit board. The recommended thermal land size for this package is 5 mm × 5 mm, with top and bottom layers connected by 9 vias. A thermal land size of 3,8 mm × 3,8 mm (as used on the DAC5674 EVM) is adequate for this device.

# DAC5674

SLWS148A – SEPTEMBER 2003 – REVISED OCTOBER 2005

## REVISION HISTORY

DATE	REV	PAGE	SECTION	DESCRIPTION
Aug. 2005	A	10–12	Typical Characteristics	Added a note that ac measurements are taken with the PLL off
		15	Low-Pass/Low-Pass 4× Interpolation Filter Operation	Updated the filter mode diagrams with more-realistic response
		16	Low-Pass/High-Pass 4× Interpolation Filter Operation	
		17	High-Pass/Low-Pass 4× Interpolation Filter Operation	
		18	High-Pass/High-Pass 4× Interpolation Filter Operation	
		18	DAC Sinx/x Output Attenuation	Added this new section
		26	DAC Transfer Function	Updated DAC transfer equation with a more-accurate model
		29	Sleep Mode	Corrected a word and added a sentence
		30	PLL Loop Filter Components	Replaced with a new section, Designing the PLL Loop Filter

## PACKAGING INFORMATION

Orderable Device	Status (1)	Package Type	Package Drawing	Pins	Package Qty	Eco Plan (2)	Lead/Ball Finish (6)	MSL Peak Temp (3)	Op Temp (°C)	Device Marking (4/5)	Samples
DAC5674IPHP	ACTIVE	HTQFP	PHP	48	250	Green (RoHS & no Sb/Br)	CU NIPDAU	Level-3-260C-168 HR	-40 to 85	DAC5674	<a href="#">Samples</a>
DAC5674IPHPG4	ACTIVE	HTQFP	PHP	48	250	Green (RoHS & no Sb/Br)	CU NIPDAU	Level-3-260C-168 HR	-40 to 85	DAC5674	<a href="#">Samples</a>
DAC5674IPHPR	ACTIVE	HTQFP	PHP	48	1000	Green (RoHS & no Sb/Br)	CU NIPDAU	Level-3-260C-168 HR	-40 to 85	DAC5674	<a href="#">Samples</a>

(1) The marketing status values are defined as follows:

**ACTIVE:** Product device recommended for new designs.

**LIFEBUY:** TI has announced that the device will be discontinued, and a lifetime-buy period is in effect.

**NRND:** Not recommended for new designs. Device is in production to support existing customers, but TI does not recommend using this part in a new design.

**PREVIEW:** Device has been announced but is not in production. Samples may or may not be available.

**OBsolete:** TI has discontinued the production of the device.

(2) Eco Plan - The planned eco-friendly classification: Pb-Free (RoHS), Pb-Free (RoHS Exempt), or Green (RoHS & no Sb/Br) - please check <http://www.ti.com/productcontent> for the latest availability information and additional product content details.

**TBD:** The Pb-Free/Green conversion plan has not been defined.

**Pb-Free (RoHS):** TI's terms "Lead-Free" or "Pb-Free" mean semiconductor products that are compatible with the current RoHS requirements for all 6 substances, including the requirement that lead not exceed 0.1% by weight in homogeneous materials. Where designed to be soldered at high temperatures, TI Pb-Free products are suitable for use in specified lead-free processes.

**Pb-Free (RoHS Exempt):** This component has a RoHS exemption for either 1) lead-based flip-chip solder bumps used between the die and package, or 2) lead-based die adhesive used between the die and leadframe. The component is otherwise considered Pb-Free (RoHS compatible) as defined above.

**Green (RoHS & no Sb/Br):** TI defines "Green" to mean Pb-Free (RoHS compatible), and free of Bromine (Br) and Antimony (Sb) based flame retardants (Br or Sb do not exceed 0.1% by weight in homogeneous material)

(3) MSL, Peak Temp. - The Moisture Sensitivity Level rating according to the JEDEC industry standard classifications, and peak solder temperature.

(4) There may be additional marking, which relates to the logo, the lot trace code information, or the environmental category on the device.

(5) Multiple Device Markings will be inside parentheses. Only one Device Marking contained in parentheses and separated by a "~" will appear on a device. If a line is indented then it is a continuation of the previous line and the two combined represent the entire Device Marking for that device.

(6) Lead/Ball Finish - Orderable Devices may have multiple material finish options. Finish options are separated by a vertical ruled line. Lead/Ball Finish values may wrap to two lines if the finish value exceeds the maximum column width.

**Important Information and Disclaimer:** The information provided on this page represents TI's knowledge and belief as of the date that it is provided. TI bases its knowledge and belief on information provided by third parties, and makes no representation or warranty as to the accuracy of such information. Efforts are underway to better integrate information from third parties. TI has taken and

continues to take reasonable steps to provide representative and accurate information but may not have conducted destructive testing or chemical analysis on incoming materials and chemicals. TI and TI suppliers consider certain information to be proprietary, and thus CAS numbers and other limited information may not be available for release.

In no event shall TI's liability arising out of such information exceed the total purchase price of the TI part(s) at issue in this document sold by TI to Customer on an annual basis.

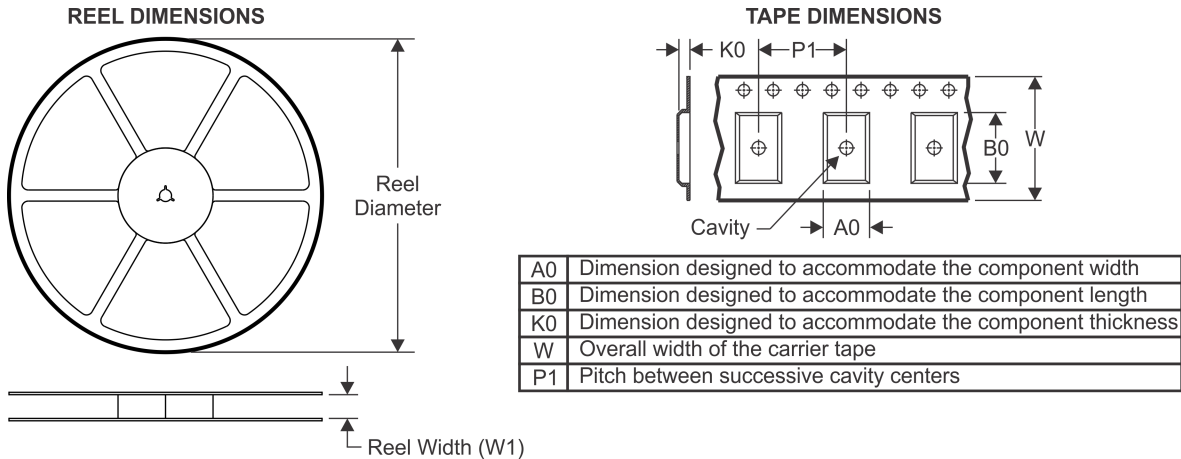
**TAPE AND REEL INFORMATION**

**QUADRANT ASSIGNMENTS FOR PIN 1 ORIENTATION IN TAPE**

\*All dimensions are nominal

Device	Package Type	Package Drawing	Pins	SPQ	Reel Diameter (mm)	Reel Width W1 (mm)	A0 (mm)	B0 (mm)	K0 (mm)	P1 (mm)	W (mm)	Pin1 Quadrant
DAC5674IPHR	HTQFP	PHP	48	1000	330.0	16.4	9.6	9.6	1.5	12.0	16.0	Q2

TAPE AND REEL BOX DIMENSIONS



\*All dimensions are nominal

Device	Package Type	Package Drawing	Pins	SPQ	Length (mm)	Width (mm)	Height (mm)
DAC5674IPHR	HTQFP	PHP	48	1000	350.0	350.0	43.0

PHP (S-PQFP-G48)

PowerPAD™ PLASTIC QUAD FLATPACK

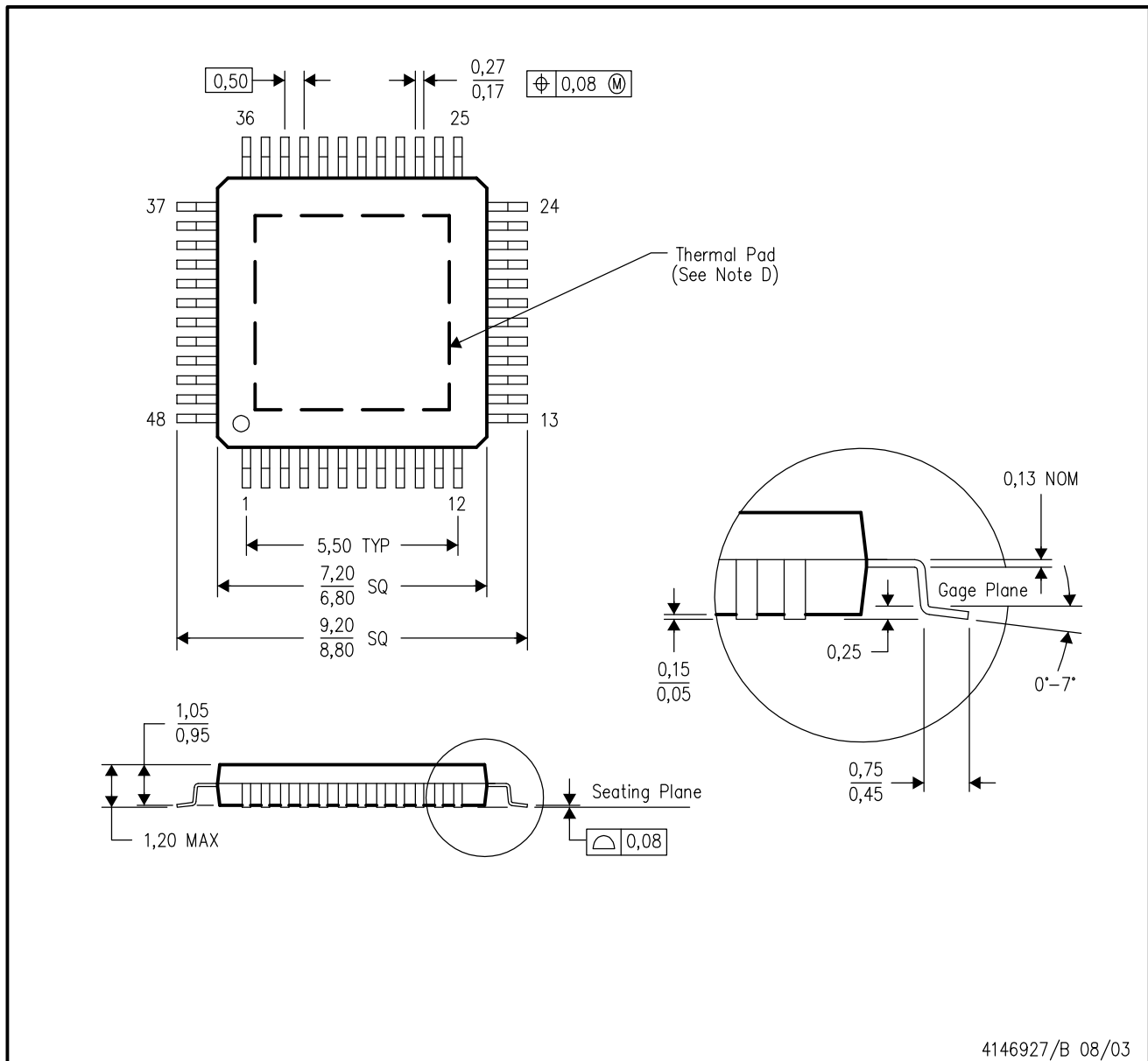

- NOTES:
- All linear dimensions are in millimeters.
  - This drawing is subject to change without notice.
  - Body dimensions do not include mold flash or protrusion.
  - This package is designed to be soldered to a thermal pad on the board. Refer to Technical Brief, PowerPad Thermally Enhanced Package, Texas Instruments Literature No. SLMA002 for information regarding recommended board layout. This document is available at [www.ti.com](http://www.ti.com) <<http://www.ti.com>>.
  - Falls within JEDEC MS-026

PowerPAD is a trademark of Texas Instruments.

# THERMAL PAD MECHANICAL DATA

PHP (S-PQFP-G48)

PowerPAD™ PLASTIC QUAD FLATPACK

## THERMAL INFORMATION

This PowerPAD™ package incorporates an exposed thermal pad that is designed to be attached to a printed circuit board (PCB). The thermal pad must be soldered directly to the PCB. After soldering, the PCB can be used as a heatsink. In addition, through the use of thermal vias, the thermal pad can be attached directly to the appropriate copper plane shown in the electrical schematic for the device, or alternatively, can be attached to a special heatsink structure designed into the PCB. This design optimizes the heat transfer from the integrated circuit (IC).

For additional information on the PowerPAD package and how to take advantage of its heat dissipating abilities, refer to Technical Brief, PowerPAD Thermally Enhanced Package, Texas Instruments Literature No. SLMA002 and Application Brief, PowerPAD Made Easy, Texas Instruments Literature No. SLMA004. Both documents are available at [www.ti.com](http://www.ti.com).

The exposed thermal pad dimensions for this package are shown in the following illustration.

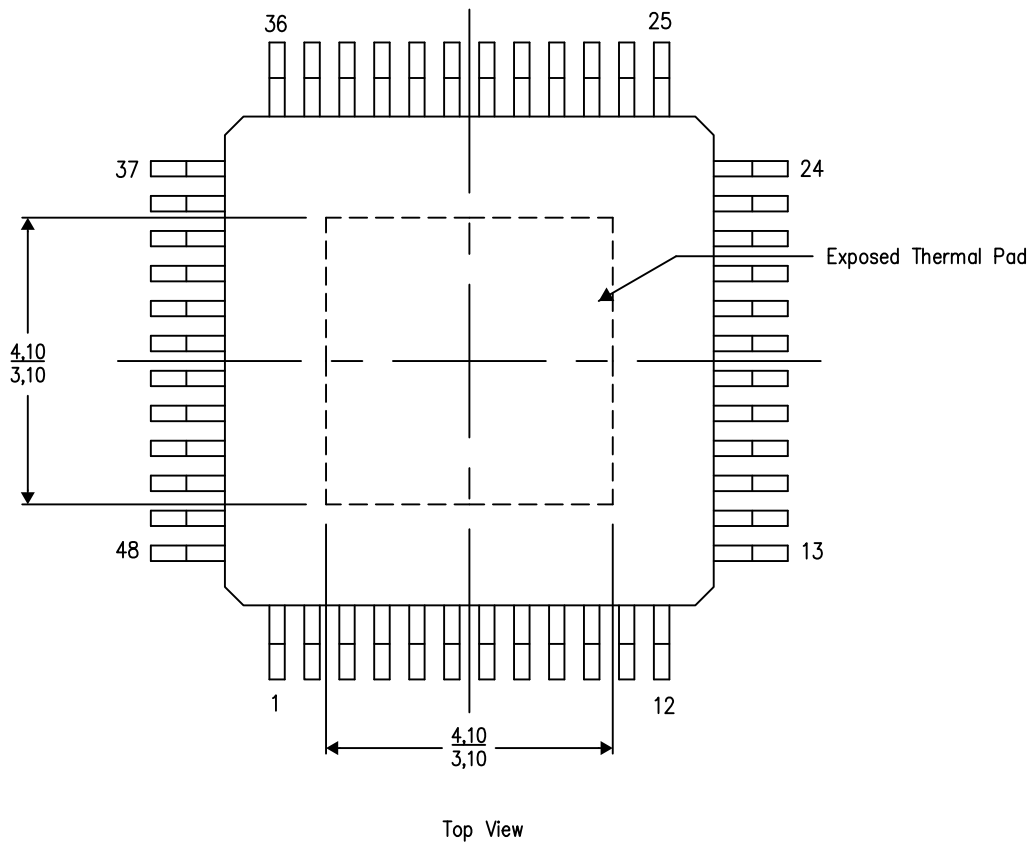

Exposed Thermal Pad Dimensions

4206329-3/P 03/15

NOTE: A. All linear dimensions are in millimeters

PowerPAD is a trademark of Texas Instruments

PHP (S-PQFP-G48)

PowerPAD™ PLASTIC QUAD FLATPACK

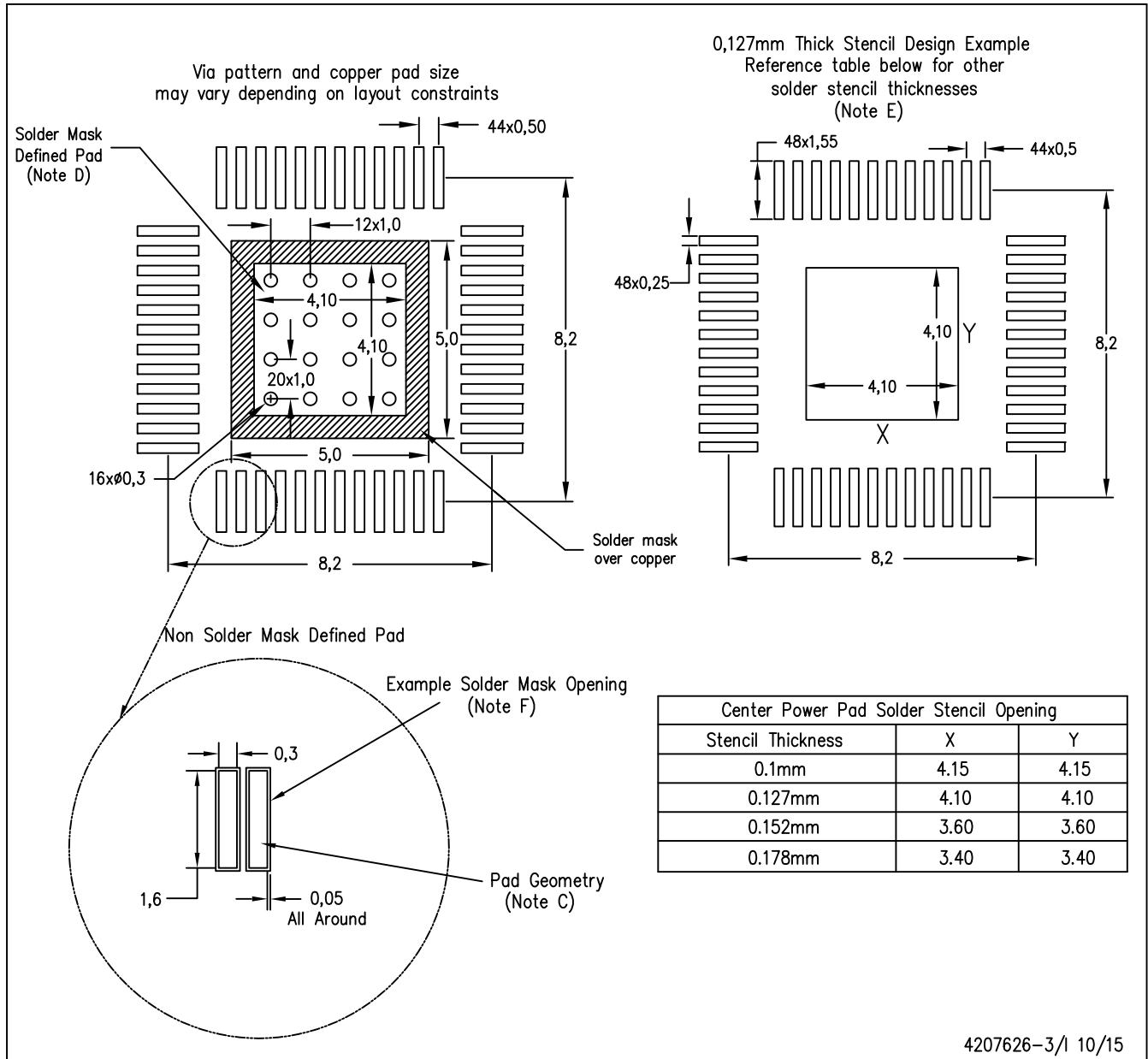

- NOTES:
- A. All linear dimensions are in millimeters.
  - B. This drawing is subject to change without notice.
  - C. Publication IPC-7351 is recommended for alternate designs.
  - D. This package is designed to be soldered to a thermal pad on the board. Refer to Technical Brief, PowerPAD Thermally Enhanced Package, Texas Instruments Literature No. SLMA002, SLMA004, and also the Product Data Sheets for specific thermal information, via requirements, and recommended board layout. These documents are available at [www.ti.com](http://www.ti.com) <<http://www.ti.com>>.
  - E. Laser cutting apertures with trapezoidal walls and also rounding corners will offer better paste release. Customers should contact their board assembly site for stencil design recommendations. Refer to IPC 7525 for stencil design considerations.
  - F. Customers should contact their board fabrication site for recommended solder mask tolerances and via tenting options for vias placed in the thermal pad.

PowerPAD is a trademark of Texas Instruments

## IMPORTANT NOTICE AND DISCLAIMER

TI PROVIDES TECHNICAL AND RELIABILITY DATA (INCLUDING DATASHEETS), DESIGN RESOURCES (INCLUDING REFERENCE DESIGNS), APPLICATION OR OTHER DESIGN ADVICE, WEB TOOLS, SAFETY INFORMATION, AND OTHER RESOURCES "AS IS" AND WITH ALL FAULTS, AND DISCLAIMS ALL WARRANTIES, EXPRESS AND IMPLIED, INCLUDING WITHOUT LIMITATION ANY IMPLIED WARRANTIES OF MERCHANTABILITY, FITNESS FOR A PARTICULAR PURPOSE OR NON-INFRINGEMENT OF THIRD PARTY INTELLECTUAL PROPERTY RIGHTS.

These resources are intended for skilled developers designing with TI products. You are solely responsible for (1) selecting the appropriate TI products for your application, (2) designing, validating and testing your application, and (3) ensuring your application meets applicable standards, and any other safety, security, or other requirements. These resources are subject to change without notice. TI grants you permission to use these resources only for development of an application that uses the TI products described in the resource. Other reproduction and display of these resources is prohibited. No license is granted to any other TI intellectual property right or to any third party intellectual property right. TI disclaims responsibility for, and you will fully indemnify TI and its representatives against, any claims, damages, costs, losses, and liabilities arising out of your use of these resources.

TI's products are provided subject to TI's Terms of Sale ([www.ti.com/legal/termsofsale.html](http://www.ti.com/legal/termsofsale.html)) or other applicable terms available either on [ti.com](http://ti.com) or provided in conjunction with such TI products. TI's provision of these resources does not expand or otherwise alter TI's applicable warranties or warranty disclaimers for TI products.

Mailing Address: Texas Instruments, Post Office Box 655303, Dallas, Texas 75265  
Copyright © 2019, Texas Instruments Incorporated

## Looking for pricing, stock, or lifecycle information?

Click below to explore more details on WIN SOURCE:

 [View DAC5674IPHP](#) on WIN SOURCE

 [Texas Instruments](#) Information

## Optimize Your Supply Chain with WIN SOURCE Solutions

-  Global Sourcing Solution
-  Obsolete Management
-  Cost Control Management
-  Shortage Management
-  Alternative Solution
-  Excess Inventory Management