



**THE DATASHEET OF  
DAC7513N/3K**





# Low-Power, Rail-to-Rail Output, 12-Bit Serial Input DIGITAL-TO-ANALOG CONVERTER

## FEATURES

- **microPOWER OPERATION:** 115 $\mu$ A at 5V
- **POWER-ON RESET TO ZERO**
- **POWER SUPPLY:** +2.7V to +5.5V
- **ENSURED MONOTONIC BY DESIGN**
- **SETTLING TIME:** 10 $\mu$ s to 1LSB
- **LOW-POWER SERIAL INTERFACE WITH SCHMITT-TRIGGERED INPUTS**
- **ON-CHIP OUTPUT BUFFER AMPLIFIER, RAIL-TO-RAIL OPERATION**
- **SYNC INTERRUPT FACILITY**
- **SOT23-8 AND MSOP-8 PACKAGES**

## APPLICATIONS

- **PROCESS CONTROL**
- **DATA ACQUISITION SYSTEMS**
- **CLOSED-LOOP SERVO-CONTROL**
- **PC PERIPHERALS**
- **PORTABLE INSTRUMENTATION**
- **PROGRAMMABLE ATTENUATION**

## DESCRIPTION

The DAC7513 is a low-power, single, 12-bit buffered voltage output Digital-to-Analog Converter (DAC). The on-chip precision output amplifier allows rail-to-rail output swing to be achieved. The DAC7513 uses a versatile 3-wire serial interface that operates at clock rates up to 30MHz and is compatible with standard SPI™, QSPI™, Microwire™, and DSP interfaces.

The DAC7513 requires an external reference voltage to set the output range of the DAC, this allows the DAC7513 to be used in a multiplying mode. The DAC7513 incorporates a power-on reset circuit which ensures that the DAC output powers up at 0V and remains there until a valid write takes place to the device. The DAC7513 contains a power-down feature, accessed over the serial interface, that reduces the current consumption of the device to 200nA at 5V.

The low-power consumption of this part in normal operation makes it ideally suited to portable battery-operated equipment. The power consumption is 0.5mW at 5V reducing to 1 $\mu$ W in power-down mode.

The DAC7513 is available in an SOT23-8 package and an MSOP-8 package.

SPI and QSPI are registered trademarks of Motorola.  
Microwire is a registered trademark of National Semiconductor.

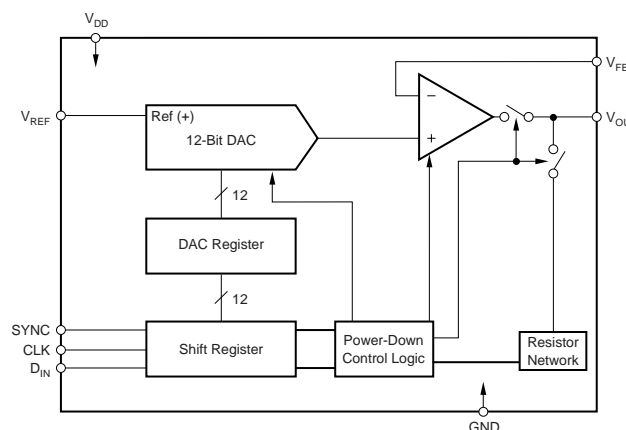

Please be aware that an important notice concerning availability, standard warranty, and use in critical applications of Texas Instruments semiconductor products and disclaimers thereto appears at the end of this data sheet.

## ABSOLUTE MAXIMUM RATINGS<sup>(1)</sup>

$V_{DD}$ to GND .....	-0.3V to +6V
Digital Input Voltage to GND .....	-0.3V to $+V_{DD} + 0.3V$
$V_{OUT}$ to GND .....	-0.3V to $+V_{DD} + 0.3V$
Operating Temperature Range .....	-40°C to +105°C
Storage Temperature Range .....	-65°C to +150°C
Junction Temperature Range ( $T_J$ max) .....	+150°C
SOT23 Package:	
Power Dissipation .....	$(T_J \text{ max} - T_A)/\theta_{JA}$
$\theta_{JA}$ Thermal Impedance .....	240°C/W
Lead Temperature, Soldering:	
Vapor Phase (60s) .....	+215°C
Infrared (15s) .....	+220°C
MSOP Package:	
Power Dissipation .....	$(T_J \text{ max} - T_A)/\theta_{JA}$
$\theta_{JA}$ Thermal Impedance .....	206°C/W
$\theta_{JC}$ Thermal Impedance .....	44°C/W
Lead Temperature, Soldering:	
Vapor Phase (60s) .....	+215°C
Infrared (15s) .....	+220°C

NOTE: (1) Stresses above those listed under *Absolute Maximum Ratings* may cause permanent damage to the device. Exposure to absolute maximum conditions for extended periods may affect device reliability.



## ELECTROSTATIC DISCHARGE SENSITIVITY

This integrated circuit can be damaged by ESD. Texas Instruments recommends that all integrated circuits be handled with appropriate precautions. Failure to observe proper handling and installation procedures can cause damage.

ESD damage can range from subtle performance degradation to complete device failure. Precision integrated circuits may be more susceptible to damage because very small parametric changes could cause the device not to meet its published specifications.

## PACKAGE/ORDERING INFORMATION

PRODUCT	MINIMUM RELATIVE ACCURACY (LSB)	DIFFERENTIAL NONLINEARITY (LSB)	PACKAGE-LEAD	PACKAGE DESIGNATOR <sup>(1)</sup>	SPECIFICATION TEMPERATURE RANGE	PACKAGE MARKING	ORDERING NUMBER	TRANSPORT MEDIA, QUANTITY
DAC7513E "	±8 "	±1 "	MSOP-8 "	DGK "	-40°C to +105°C "	D13E "	DAC7513E/250 DAC7513E/2K5	Tape and Reel, 250 Tape and Reel, 2500
DAC7513N "	±8 "	±1 "	SOT23-8 "	DCN "	-40°C to +105°C "	D13N "	DAC7513N/250 DAC7513N/3K	Tape and Reel, 250 Tape and Reel, 3000

NOTE: (1) For the most current specifications and package information, refer to our web site at [www.ti.com](http://www.ti.com).

## PIN CONFIGURATIONS

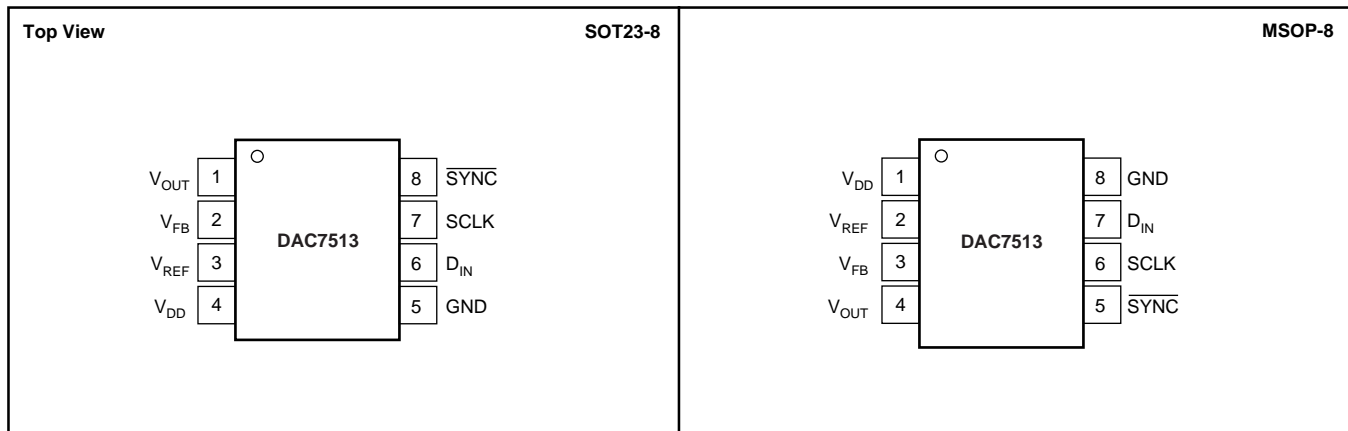

## MARKING ARTWORK

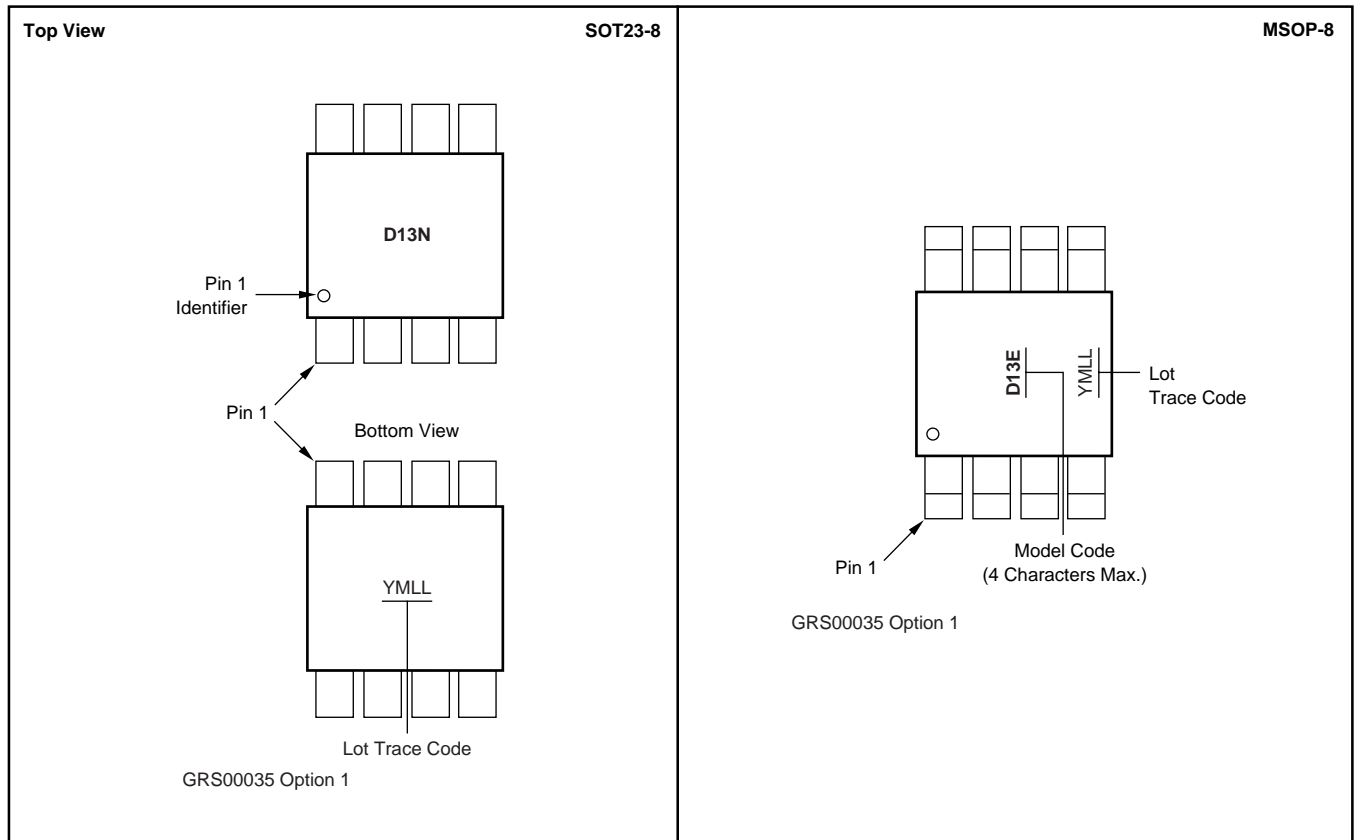

## PIN DESCRIPTIONS

MSOP-8	SOT23-8	NAME	DESCRIPTION
1	4	$V_{DD}$	Power Supply Input, +2.7V to +5.5V
2	3	$V_{REF}$	Reference Voltage Input
3	2	$V_{FB}$	Feedback connection for the output amplifier.
4	1	$V_{OUT}$	Analog output voltage from DAC. The output amplifier has rail-to-rail operation.
5	8	$\overline{SYNC}$	Level triggered control input (active LOW), this is the frame synchronization signal for the input data. When $\overline{SYNC}$ goes LOW, it enables the input shift register and data is transferred in on the falling edges of the following clocks. The DAC is updated following the 16th clock cycle unless $\overline{SYNC}$ is taken HIGH before this edge in which case the rising edge of SYNC acts as an interrupt and the write sequence is ignored by the DAC7513.
6	7	SCLK	Serial Clock Input. Data can be transferred at rates up to 30MHz.
7	6	$D_{IN}$	Serial Data Input. Data is clocked into the 16-bit input shift register on the falling edge of the serial clock input.
8	5	GND	Ground reference point for all circuitry on the part.



# TIMING CHARACTERISTICS(1, 2)

$V_{DD} = +2.7V$  to  $+5.5V$ , all specifications  $-40^{\circ}C$  to  $+105^{\circ}C$ , unless otherwise noted.

PARAMETER	DESCRIPTION	CONDITIONS	DAC7513E, N			UNITS
			MIN	TYP	MAX	
$t_1^{(3)}$	SCLK Cycle Time	$V_{DD} = 2.7V$ to $3.6V$ $V_{DD} = 3.6V$ to $5.5V$	50 33			ns ns
$t_2$	SCLK HIGH Time	$V_{DD} = 2.7V$ to $3.6V$ $V_{DD} = 3.6V$ to $5.5V$	13 13			ns ns
$t_3$	SCLK LOW Time	$V_{DD} = 2.7V$ to $3.6V$ $V_{DD} = 3.6V$ to $5.5V$	22.5 13			ns ns
$t_4$	$\overline{SYNC}$ to SCLK Rising Edge Setup Time	$V_{DD} = 2.7V$ to $3.6V$ $V_{DD} = 3.6V$ to $5.5V$	0 0			ns ns
$t_5$	Data Setup Time	$V_{DD} = 2.7V$ to $3.6V$ $V_{DD} = 3.6V$ to $5.5V$	5 5			ns ns
$t_6$	Data Hold Time	$V_{DD} = 2.7V$ to $3.6V$ $V_{DD} = 3.6V$ to $5.5V$	4.5 4.5			ns ns
$t_7$	SCLK Falling Edge to $\overline{SYNC}$ Rising Edge	$V_{DD} = 2.7V$ to $3.6V$ $V_{DD} = 3.6V$ to $5.5V$	0 0			ns ns
$t_8$	Minimum $\overline{SYNC}$ HIGH Time	$V_{DD} = 2.7V$ to $3.6V$ $V_{DD} = 3.6V$ to $5.5V$	50 33			ns ns

NOTES: (1) All input signals are specified with  $t_R = t_F = 5ns$  (10% to 90% of  $V_{DD}$ ) and timed from a voltage level of  $(V_{IL} + V_{IH})/2$ . (2) See Serial Write Operation timing diagram, below. (3) Maximum SCLK frequency is 30MHz at  $V_{DD} = +3.6V$  to  $+5.5V$  and 20MHz at  $V_{DD} = +2.7V$  to  $+3.6V$ .

## SERIAL WRITE OPERATION

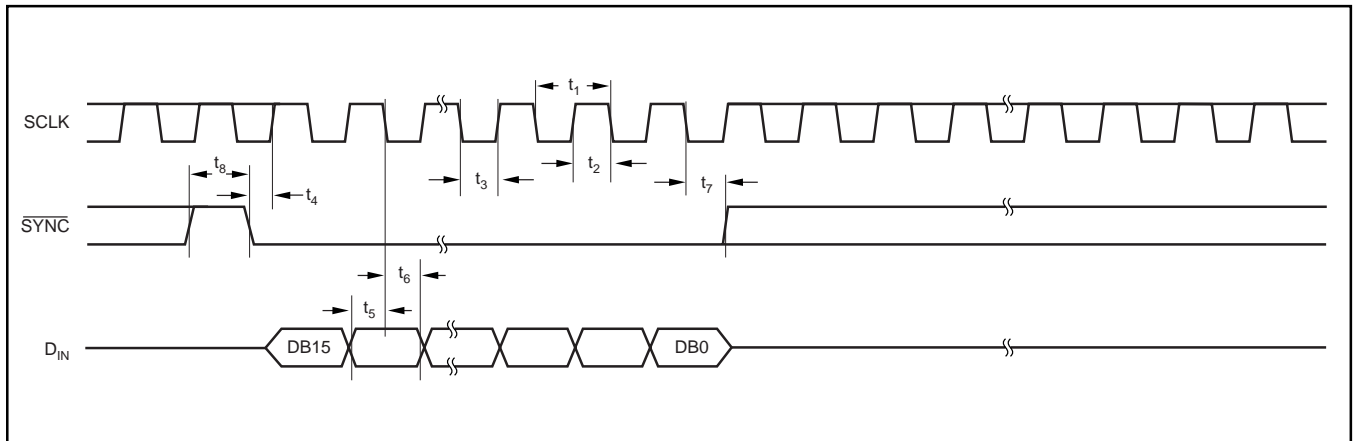

# TYPICAL CHARACTERISTICS: $V_{DD} = +5V$

At  $T_A = +25^\circ\text{C}$  and  $+V_{DD} = +5V$ , unless otherwise noted.

LINEARITY ERROR AND DIFFERENTIAL LINEARITY ERROR vs CODE  
( $-40^\circ\text{C}$ )

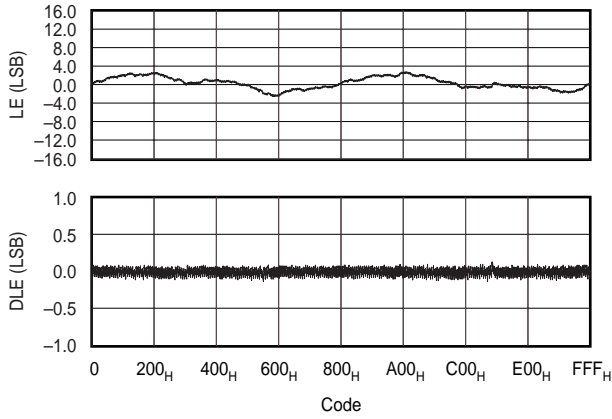

LINEARITY ERROR AND DIFFERENTIAL LINEARITY ERROR vs CODE  
( $+25^\circ\text{C}$ )

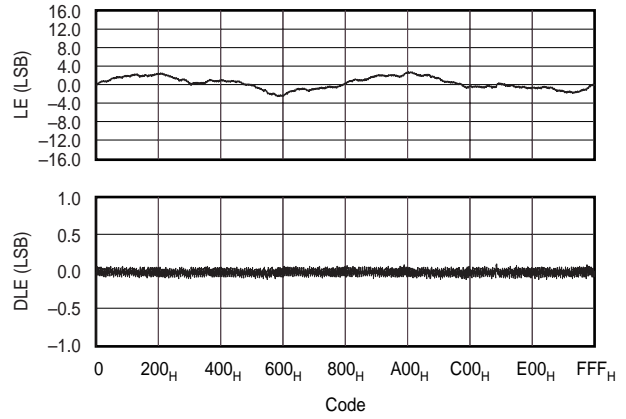

LINEARITY ERROR AND DIFFERENTIAL LINEARITY ERROR vs CODE  
( $+105^\circ\text{C}$ )

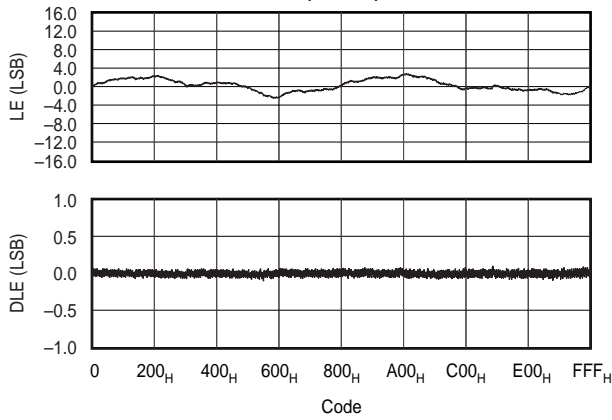

TYPICAL TOTAL UNADJUSTED ERROR

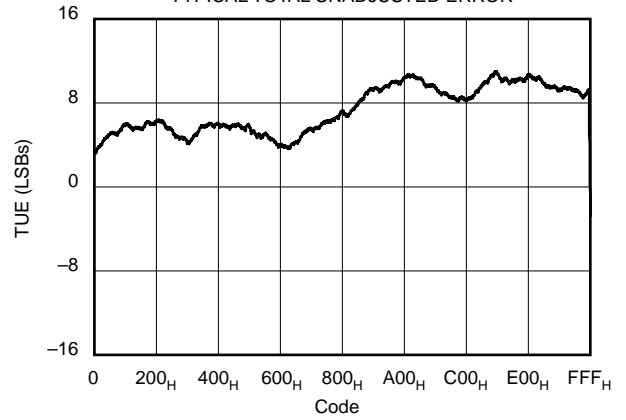

ZERO-SCALE ERROR vs TEMPERATURE

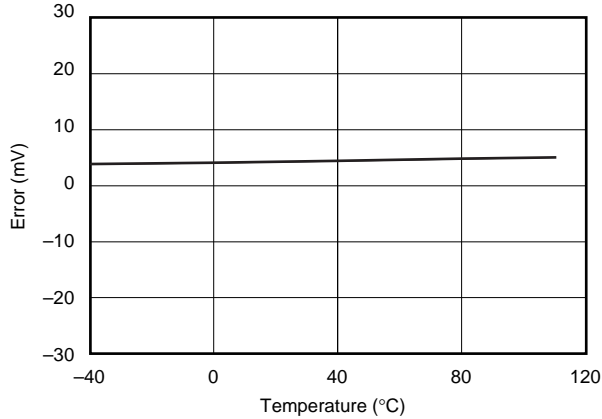

FULL-SCALE ERROR vs TEMPERATURE

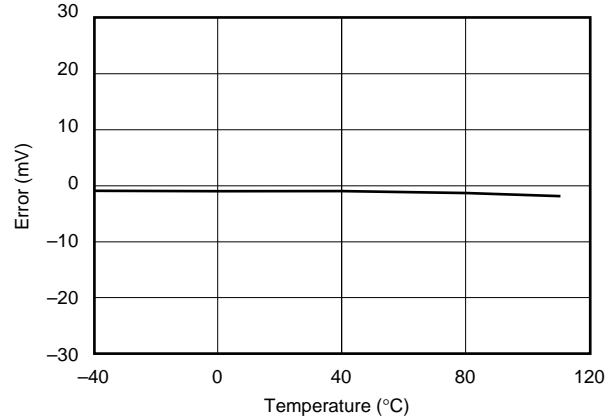

# TYPICAL CHARACTERISTICS: $V_{DD} = +5V$ (Cont.)

At  $T_A = +25^\circ\text{C}$  and  $+V_{DD} = +5V$ , unless otherwise noted.

NOTE: All references to  $I_{DD}$  include  $I_{REF}$  current.

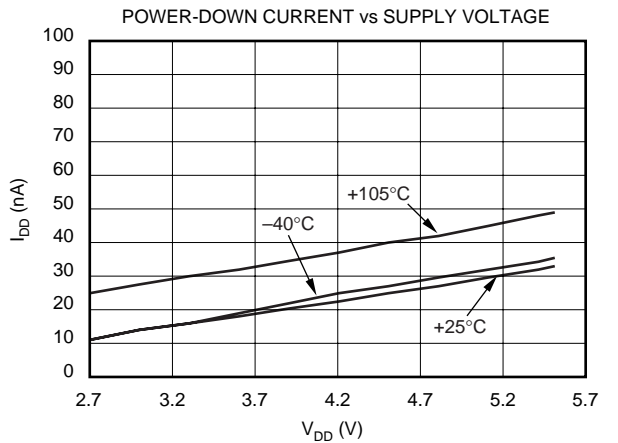
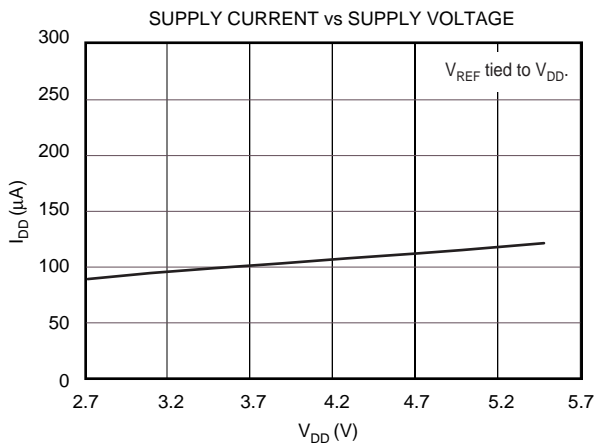
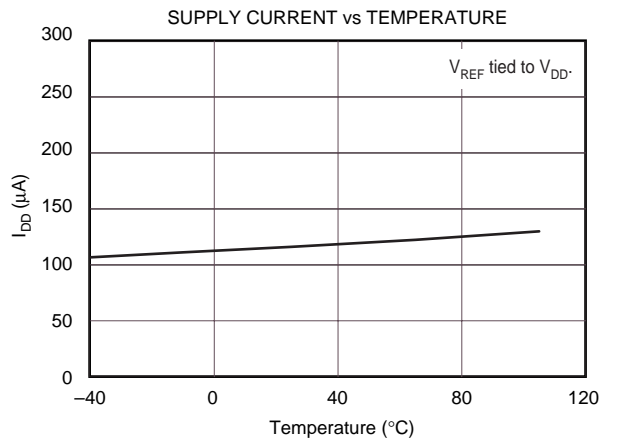
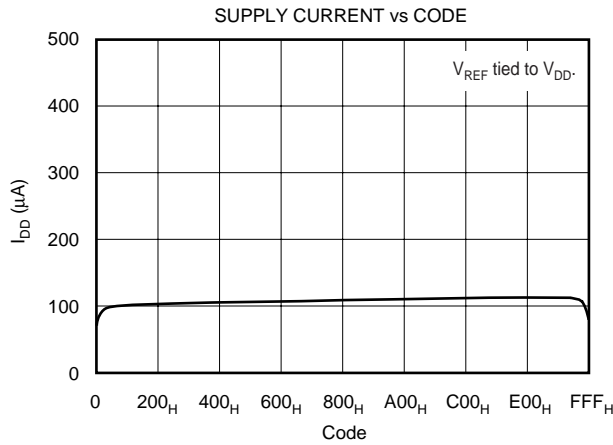
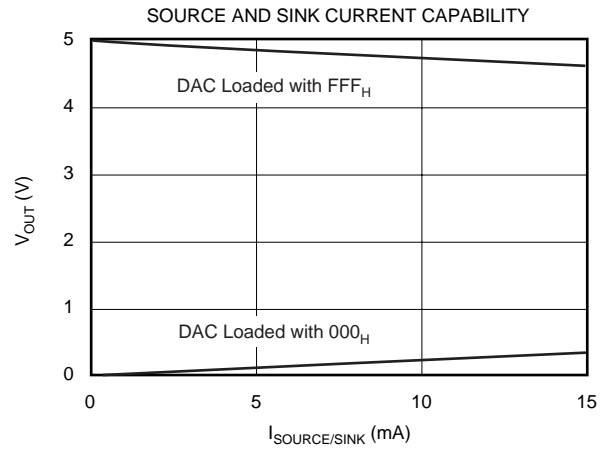
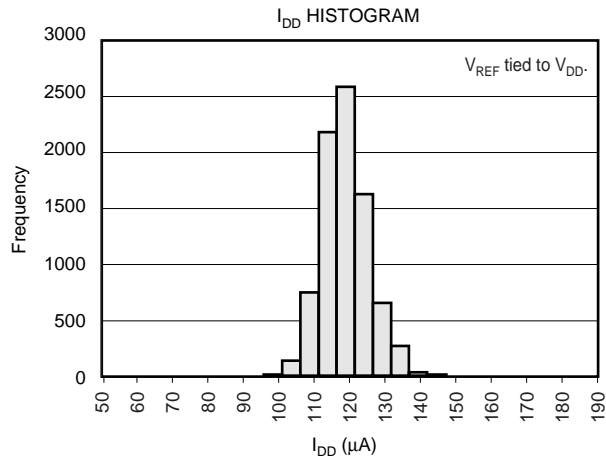

# TYPICAL CHARACTERISTICS: $V_{DD} = +5V$ (Cont.)

At  $T_A = +25^\circ\text{C}$  and  $+V_{DD} = +5V$ , unless otherwise noted.

NOTE: All references to  $I_{DD}$  include  $I_{REF}$  current.

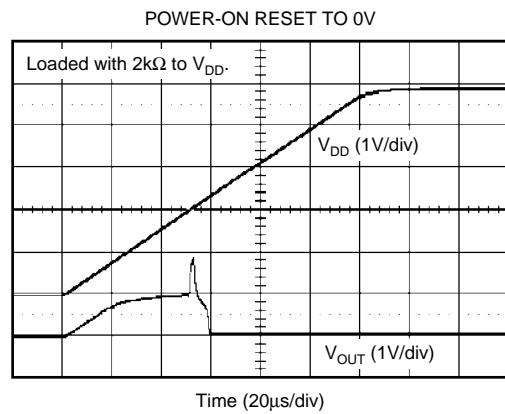
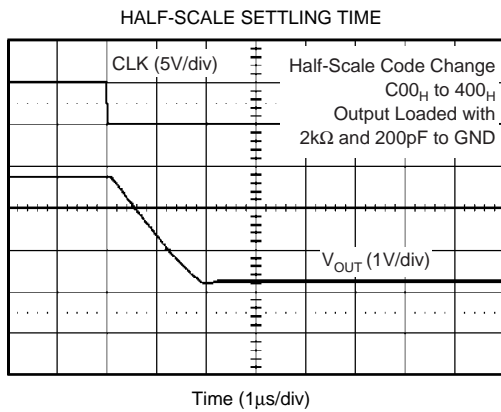
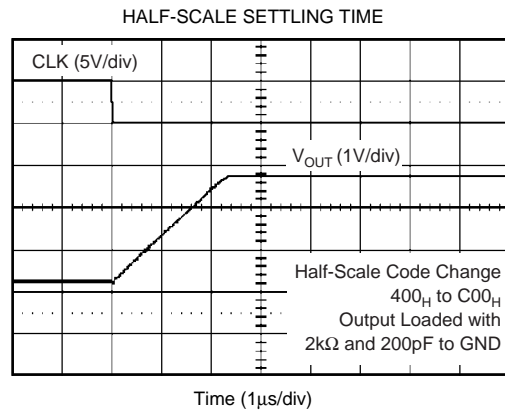
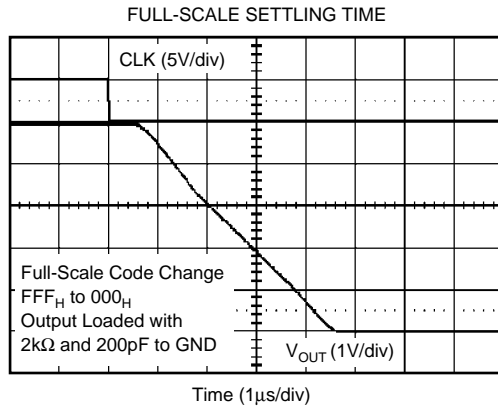
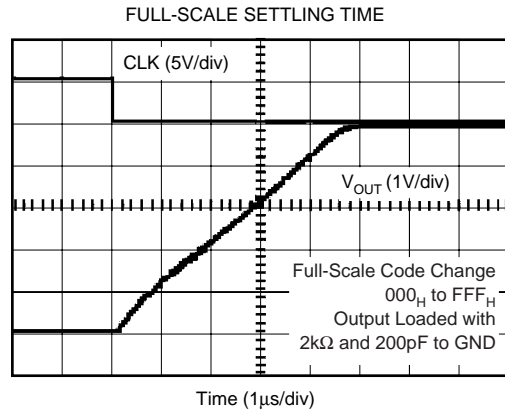
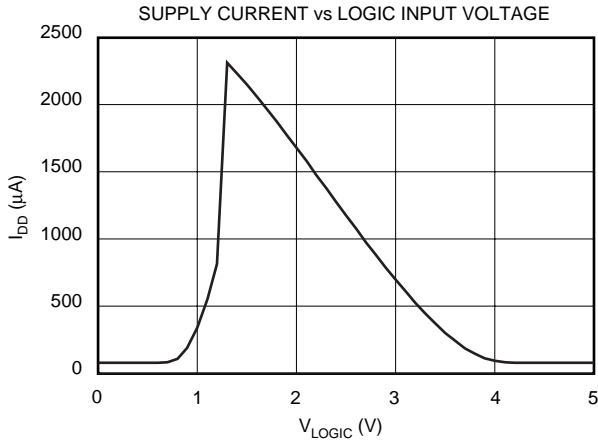

# TYPICAL CHARACTERISTICS: $V_{DD} = +5V$ (Cont.)

At  $T_A = +25^\circ\text{C}$  and  $+V_{DD} = +5V$ , unless otherwise noted.

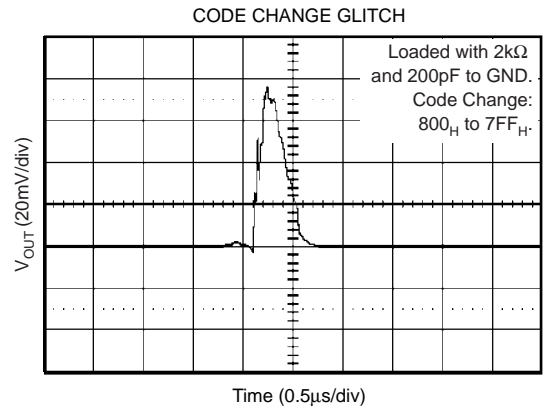
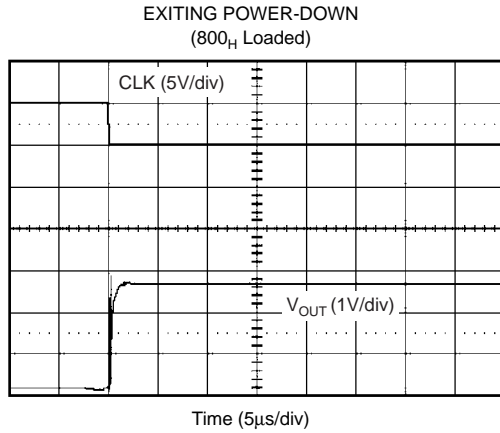

# TYPICAL CHARACTERISTICS: $V_{DD} = +2.7V$

At  $T_A = +25^\circ\text{C}$  and  $+V_{DD} = +2.7V$ , unless otherwise noted.

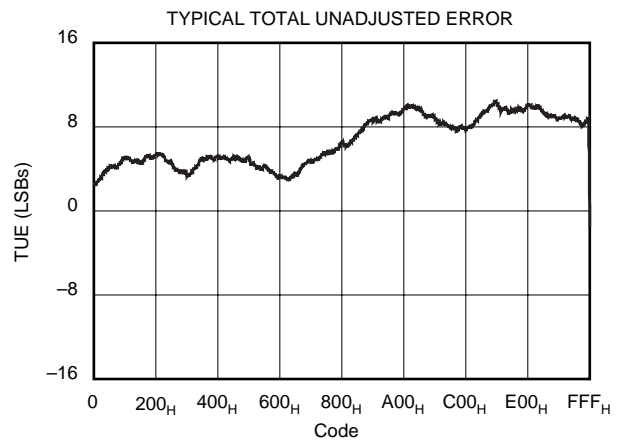
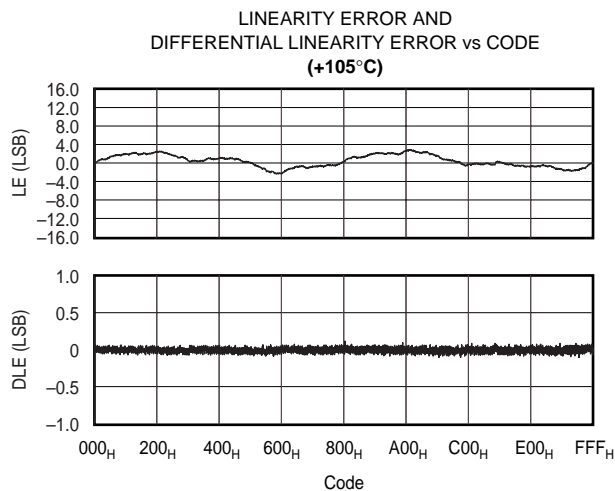
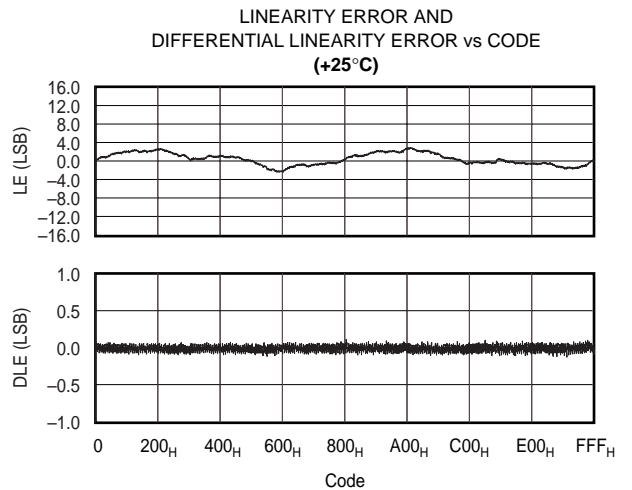
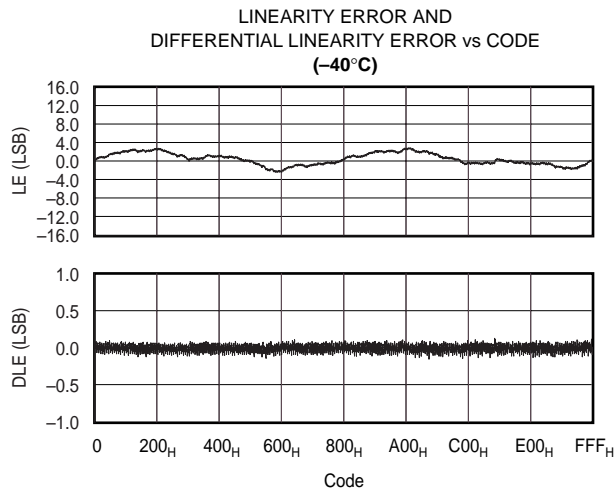

# TYPICAL CHARACTERISTICS: $V_{DD} = +2.7V$ (Cont.)

At  $T_A = +25^\circ C$  and  $+V_{DD} = +2.7V$ , unless otherwise noted.

NOTE: All references to  $I_{DD}$  include  $I_{REF}$  current.

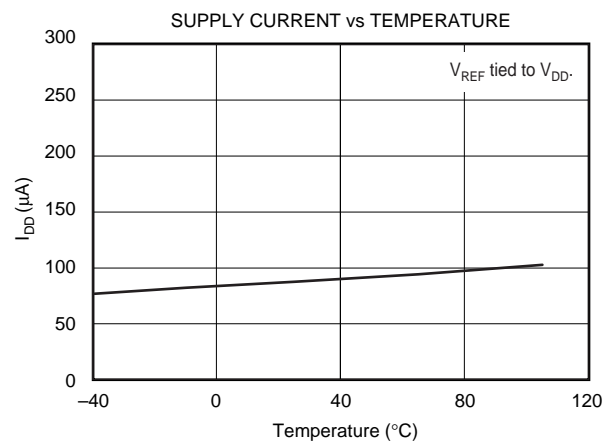
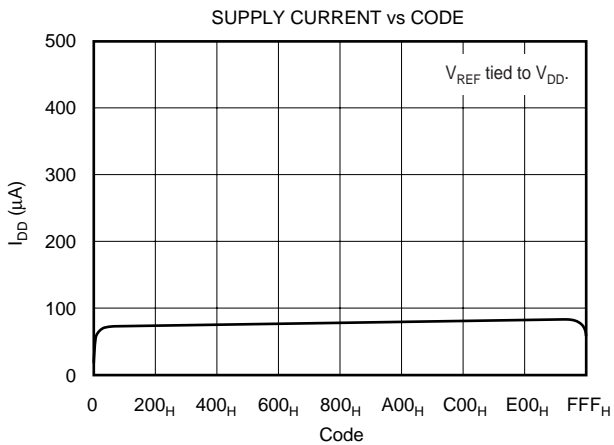
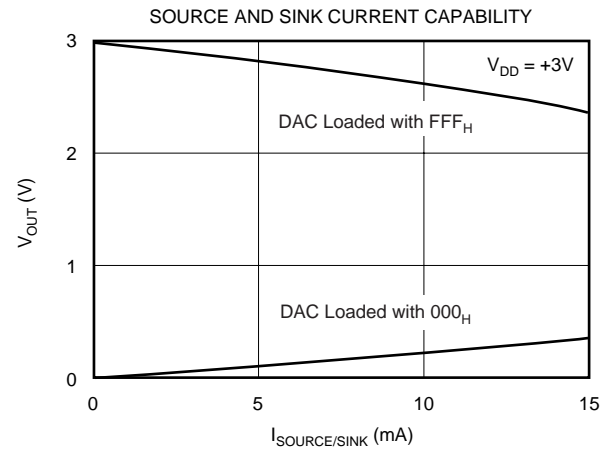
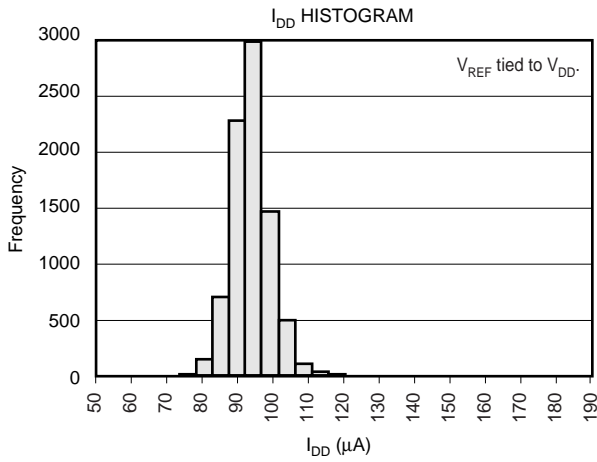
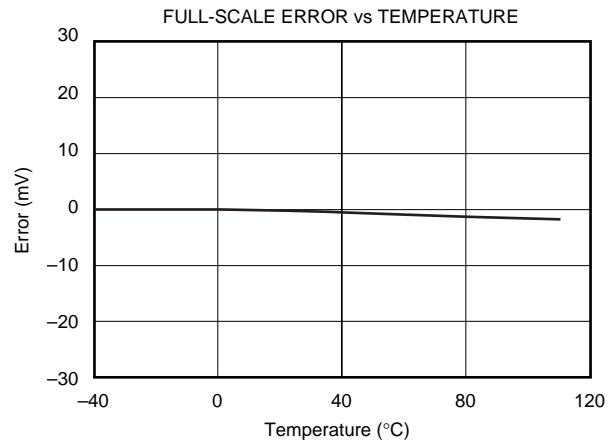
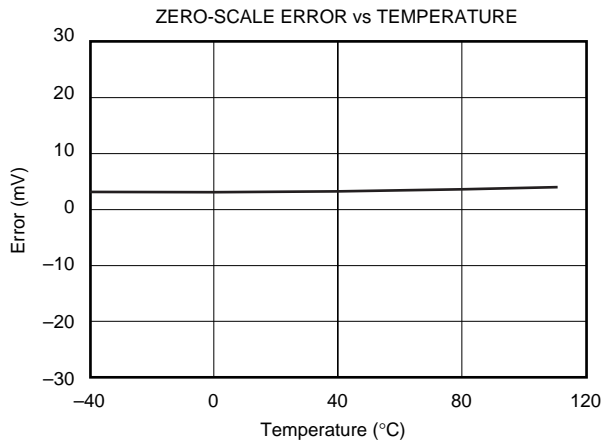

# TYPICAL CHARACTERISTICS: $V_{DD} = +2.7V$ (Cont.)

At  $T_A = +25^\circ C$  and  $+V_{DD} = +2.7V$ , unless otherwise noted.

NOTE: All references to  $I_{DD}$  include  $I_{REF}$  current.

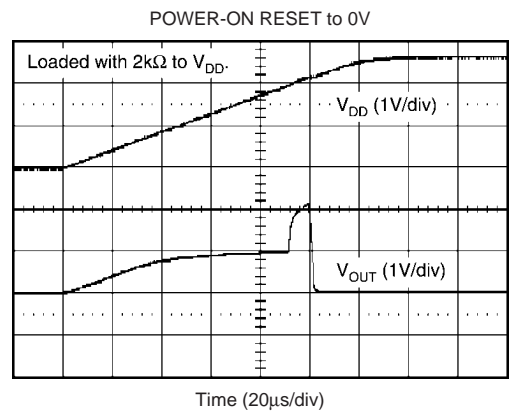
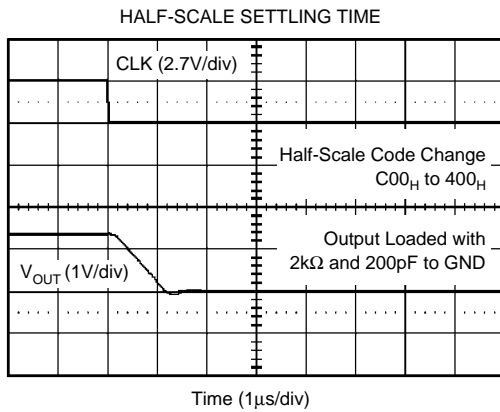
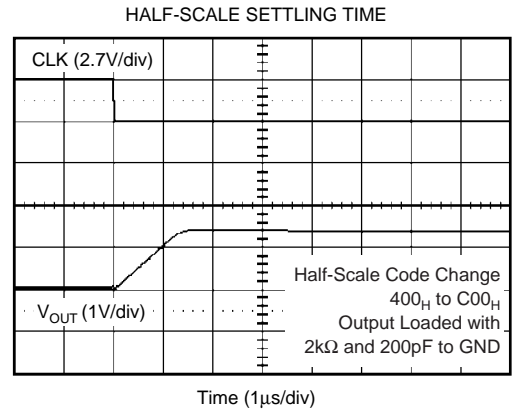
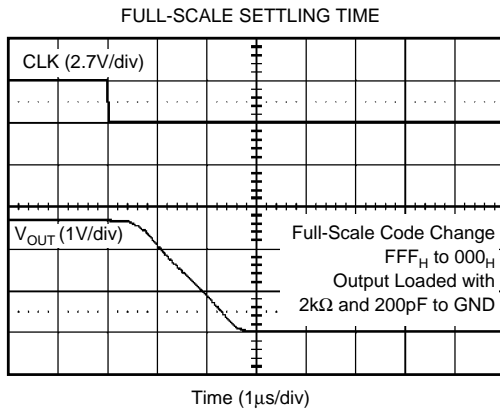
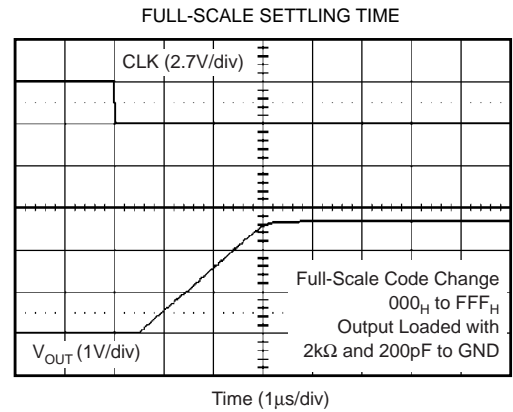
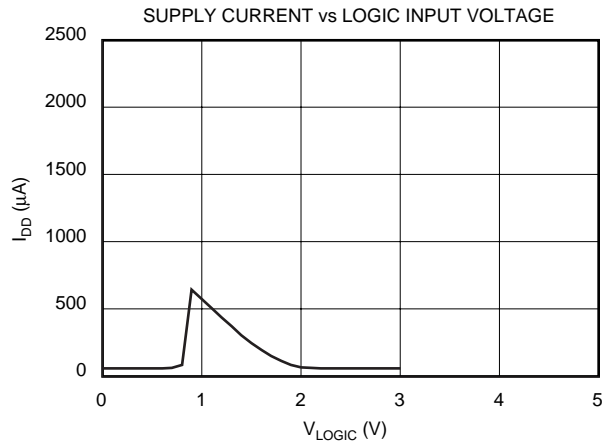

# TYPICAL CHARACTERISTICS: $V_{DD} = +2.7V$ (Cont.)

At  $T_A = +25^\circ C$  and  $+V_{DD} = +2.7V$ , unless otherwise noted.

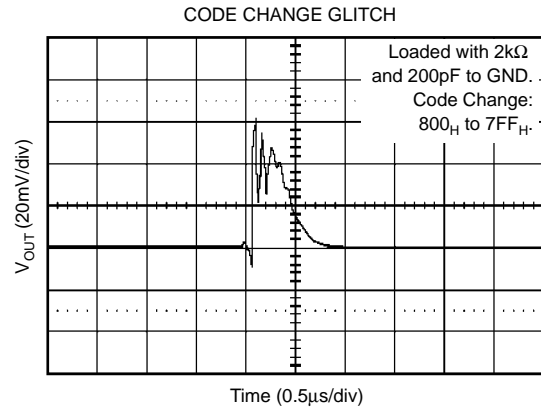
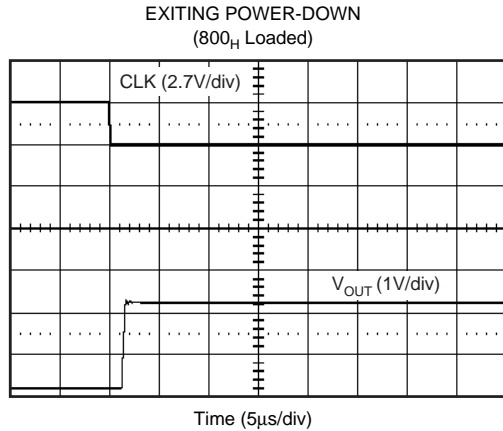

## THEORY OF OPERATION

### DAC SECTION

The architecture consists of a string DAC followed by an output buffer amplifier. Figure 1 shows a block diagram of the DAC architecture.

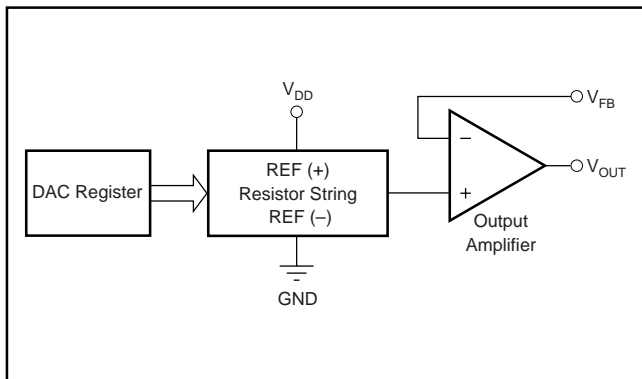

FIGURE 1. DAC7513 Architecture.

The input coding to the DAC7513 is straight binary, so the ideal output voltage is given by:

$$V_{OUT} = V_{REF} \cdot \frac{D}{4096} \quad (1)$$

where  $D$  = decimal equivalent of the binary code that is loaded to the DAC register; it can range from 0 to 4095.

### RESISTOR STRING

The resistor string shown in Figure 2 is simply a string of resistors, each of value  $R$ . The code loaded into the DAC register determines at which node on the string the voltage is tapped off to be fed into the output amplifier by closing one of the switches connecting the string to the amplifier. It is ensured monotonic because it is a string of resistors.

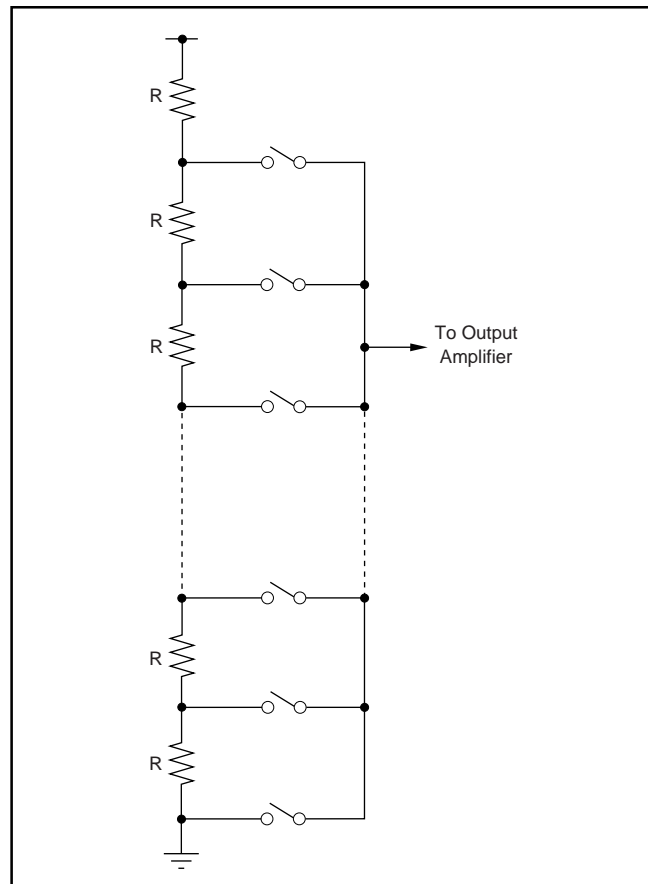

FIGURE 2. Resistor String.

### OUTPUT AMPLIFIER

The output buffer amplifier is capable of generating rail-to-rail voltages on its output which gives an output range of 0V to  $V_{DD}$ , it is capable of driving a load of  $2k\Omega$  in parallel with  $1000pF$  to GND. The source and sink capabilities of the output amplifier can be seen in the typical characteristics. The slew rate is  $1V/\mu s$  with a half-scale settling time of  $8\mu s$  with the output unloaded.

The inverting input of the output amplifier is brought out to the  $V_{FB}$  pin. This allows for better accuracy in critical applications by tying the  $V_{FB}$  point and the amplifier output together directly at the load. Other signal conditioning circuitry can also be connected between these points for specific applications.

## SERIAL INTERFACE

The DAC7513 has a 3-wire serial interface  $\overline{SYNC}$ , SCLK, and  $D_{IN}$ , which is compatible with SPI, QSPI, and Microwire interface standards as well as most Digital Signal Processors (DSPs). See the Serial Write Operation timing diagram for an example of a typical write sequence.

The write sequence begins by bringing the  $\overline{SYNC}$  line LOW, data from the  $D_{IN}$  line is clocked into the 16-bit shift register on the falling edge of SCLK. The serial clock frequency can be as high as 30MHz, making the DAC7513 compatible with high-speed DSPs. On the 16th falling edge of the serial clock, the last data bit is clocked in and the programmed function is executed (i.e., a change in the DAC register contents and/or a change in the mode of operation).

At this point, the  $\overline{SYNC}$  line may be kept LOW or brought HIGH. In either case, it must be brought HIGH for a minimum of 33ns before the next write sequence so that a falling edge of  $\overline{SYNC}$  can initiate the next write sequence. As the  $\overline{SYNC}$  buffer draws more current when the  $\overline{SYNC}$  signal is HIGH than it does when it is LOW,  $\overline{SYNC}$  must be idled LOW between write sequences for lowest power operation of the part. As mentioned above, however, it must be brought HIGH again just before the next write sequence.

### INPUT SHIFT REGISTER

The input shift register is 16 bits wide, as shown in Figure 3. The first two bits are *don't cares*. The next two bits (PD1 and PD0) are control bits that control which mode of operation the part is in (normal mode or any one of three power-down modes). There is a more complete description of the various modes in the Power-Down Modes section. The next 12 bits are the data bits. These are transferred to the DAC register on the 16th falling edge of SCLK.

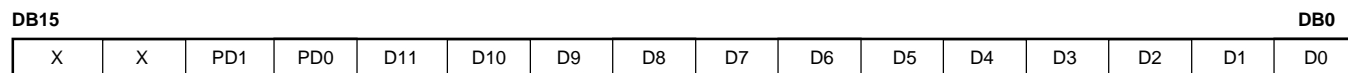

FIGURE 3. Data Input Register.

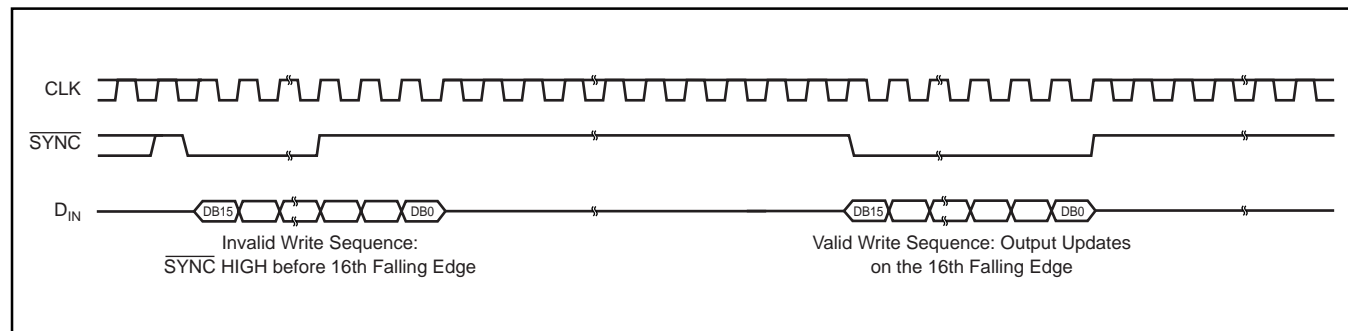

FIGURE 4.  $\overline{SYNC}$  Interrupt Facility.

## SYNC INTERRUPT

In a normal write sequence, the  $\overline{SYNC}$  line is kept LOW for at least 16 falling edges of SCLK and the DAC is updated on the 16th falling edge. However, if  $\overline{SYNC}$  is brought HIGH before the 16th falling edge, this acts as an interrupt to the write sequence. The shift register is reset and the write sequence is seen as invalid. Neither an update of the DAC register contents or a change in the operating mode occurs, as shown in Figure 4.

### POWER-ON RESET

The DAC7513 contains a power-on reset circuit that controls the output voltage during power-up. Upon power up, the DAC register is filled with zeros and the output voltage is 0V; it remains there until a valid write sequence is made to the DAC. This is useful in applications where it is important to know the state of the output of the DAC while it is in the process of powering up.

### POWER-DOWN MODES

The DAC7513 contains four separate modes of operation, which are programmable by setting two bits (PD1 and PD0) in the control register. Table I shows how the state of the bits corresponds to the mode of operation of the device.

DB13	DB12	OPERATING MODE
0	0	Normal Operation
0	1	Power-Down Modes Output 1k $\Omega$ to GND
1	0	Output 100k $\Omega$ to GND
1	1	High-Z

TABLE I. Modes of Operation for the DAC7513.

When both bits are set to 0, the part works normally with its normal power consumption of 115 $\mu$ A at 5V. However, for the three power-down modes, the supply current falls to 200nA at 5V (50nA at 3V). Not only does the supply current fall, but the output stage is also internally switched from the output of the amplifier to a resistor network of known values. This has

the advantage that the output impedance of the part is known while the part is in power-down mode. There are three different options: the output is connected internally to GND through a 1kΩ resistor; a 100kΩ resistor; or it is left open-circuited (High-Z). The output stage is illustrated in Figure 5.

All linear circuitry is shut down when the power-down mode is activated, however, the contents of the DAC register are unaffected when in power-down. The time to exit power-down is typically 2.5μs for V<sub>DD</sub> = 5V, and 5μs for V<sub>DD</sub> = 3V, (see the Typical Characteristics for more information).

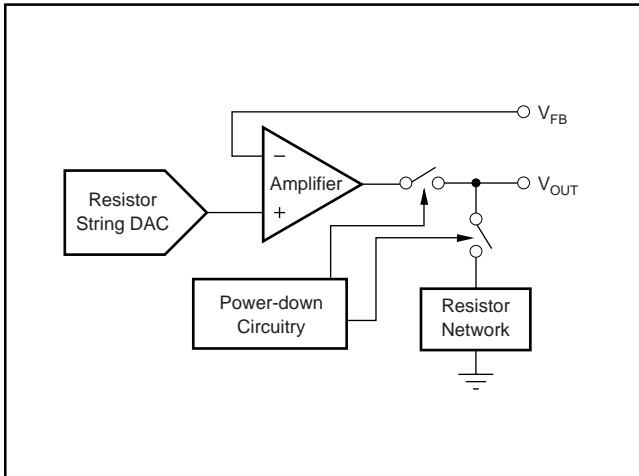

FIGURE 5. Output Stage During Power-Down.

## MICROPROCESSOR INTERFACING

### DAC7513 TO 8051 INTERFACE

Figure 6 shows a serial interface between the DAC7513 and a typical 8051-type microcontroller. The setup for the interface is as follows: TXD of the 8051 drives SCLK of the DAC7513, while RXD drives the serial data line of the part; the  $\overline{\text{SYNC}}$  signal is derived from a bit programmable pin on the port. In this case, port line P3.3 is used. When data is to be transmitted to the DAC7513, P3.3 is taken LOW. The 8051 transmits data only in 8-bit bytes; thus only eight falling clock edges occur in the transmit cycle. To load data to the DAC, P3.3 is left LOW after the first eight bits are transmitted, a second write cycle is initiated to transmit the second byte

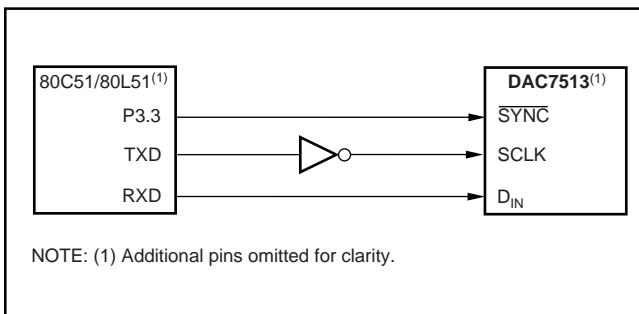

FIGURE 6. DAC7513 to 80C51/80L51 Interface.

of data, and P3.3 is taken HIGH following the completion of this cycle. The 8051 outputs the serial data in a format which has the LSB first. The DAC7513 requires its data with the MSB as the first bit received, thus, the 8051 transmit routine must therefore take this into account and mirror the data as needed.

### DAC7513 TO Microwire INTERFACE

Figure 7 shows an interface between the DAC7513 and any Microwire compatible device. Serial data is shifted out on the falling edge of the serial clock and is clocked into the DAC7513 on the rising edge of the SK signal.

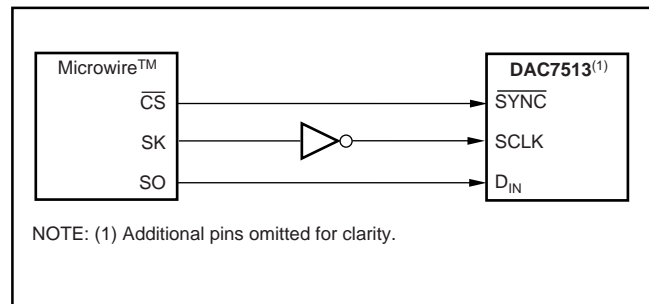

FIGURE 7. DAC7513 to Microwire Interface.

### DAC7513 TO 68HC11 INTERFACE

Figure 8 shows a serial interface between the DAC7513 and the 68HC11 microcontroller. SCK of the 68HC11 drives the SCLK of the DAC7513, while the MOSI output drives the serial data line of the DAC. The  $\overline{\text{SYNC}}$  signal is derived from a port line (PC7), similar to what was done for the 8051.

The 68HC11 must be configured so that its CPOL bit is a 0 and its CPHA bit is a 1, this configuration causes data appearing on the MOSI output as valid on the falling edge of SCK. When data is being transmitted to the DAC, the  $\overline{\text{SYNC}}$  line is taken LOW (PC7). Serial data from the 68HC11 is transmitted in 8-bit bytes with only eight falling clock edges occurring in the transmit cycle. Data is transmitted MSB first. In order to load data to the DAC7513, PC7 is left LOW after the first eight bits are transferred, and a second serial write operation is performed to the DAC and PC7 is taken HIGH at the end of this procedure.

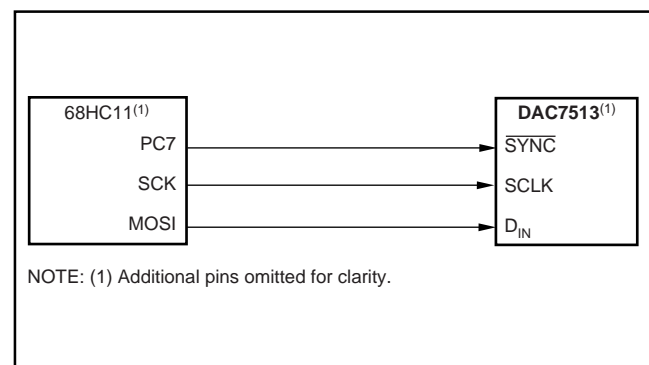

FIGURE 8. DAC7513 to 68HC11 Interface.

# APPLICATIONS

## USING REF02 AS A POWER SUPPLY FOR THE DAC7513

Due to the extremely low supply current required by the DAC7513, an alternative option is to use a REF02 +5V precision voltage reference to supply the required voltage to the part, as shown in Figure 9. This is especially useful if the power supply is quite noisy or if the system supply voltages are at some value other than 5V. The REF02 will output a steady supply voltage for the DAC7513; if the REF02 is used, the current it needs to supply to the DAC7513 is 132µA. This is with no load on the output of the DAC, so when the DAC output is loaded, the REF02 also needs to supply the current to the load. The total current required (with a 5kΩ load on the DAC output) is:

$$132\mu\text{A} + (5\text{V}/5\text{k}\Omega) = 1.13\text{mA} \quad (2)$$

The load regulation of the REF02 is typically 0.005%/mA, which results in an error of 285µV for the 1.13mA current drawn from it; this corresponds to a 0.2LSB error.

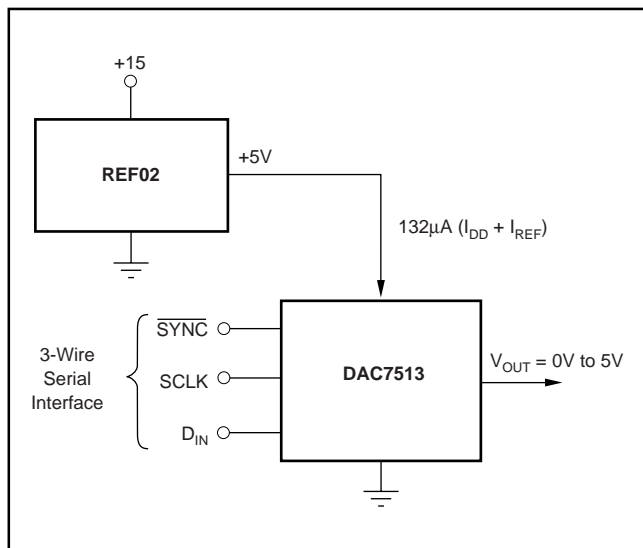

FIGURE 9. REF02 as Power Supply to the DAC7513.

## BIPOLAR OPERATION USING THE DAC7513

The DAC7513 has been designed for single-supply operation, but a bipolar output range is also possible using the circuit in Figure 10 which will give an output voltage range of ±V<sub>REF</sub>. Rail-to-rail operation at the amplifier output is achievable using an OPA703 as the output amplifier.

The output voltage for any input code can be calculated as follows:

$$V_O = \left[ V_{REF} \cdot \left( \frac{D}{4096} \right) \cdot \left( \frac{R_1 + R_2}{R_1} \right) - V_{REF} \cdot \left( \frac{R_2}{R_1} \right) \right] \quad (3)$$

where D represents the input code in decimal (0 to 4095).

With V<sub>REF</sub> = 5V, R<sub>1</sub> = R<sub>2</sub> = 10kΩ:

$$V_O = \left( \frac{10 \cdot D}{4096} \right) - 5V \quad (4)$$

This is an output voltage range of ±5V with 000<sub>H</sub> corresponding to a -5V output and FFF<sub>H</sub> corresponding to a +5V output. Similarly, using V<sub>REF</sub> = 2.5V, ±2.5V output voltage range can be achieved.

## LAYOUT

A precision analog component requires careful layout, adequate bypassing, and clean, well-regulated power supplies.

As the DAC7513 offers single-supply operation, it will often be used in close proximity with digital logic, microcontrollers, microprocessors, and digital signal processors. The more digital logic present in the design and the higher the switching speed, the more difficult it will be to achieve good performance from the converter.

Due to the single ground pin of the DAC7513, all return currents, including digital and analog return currents, must flow through the GND pin, which would, ideally, be connected directly to an analog ground plane. This plane would be separate from the ground connection for the digital components until they were connected at the power-entry point of the system.

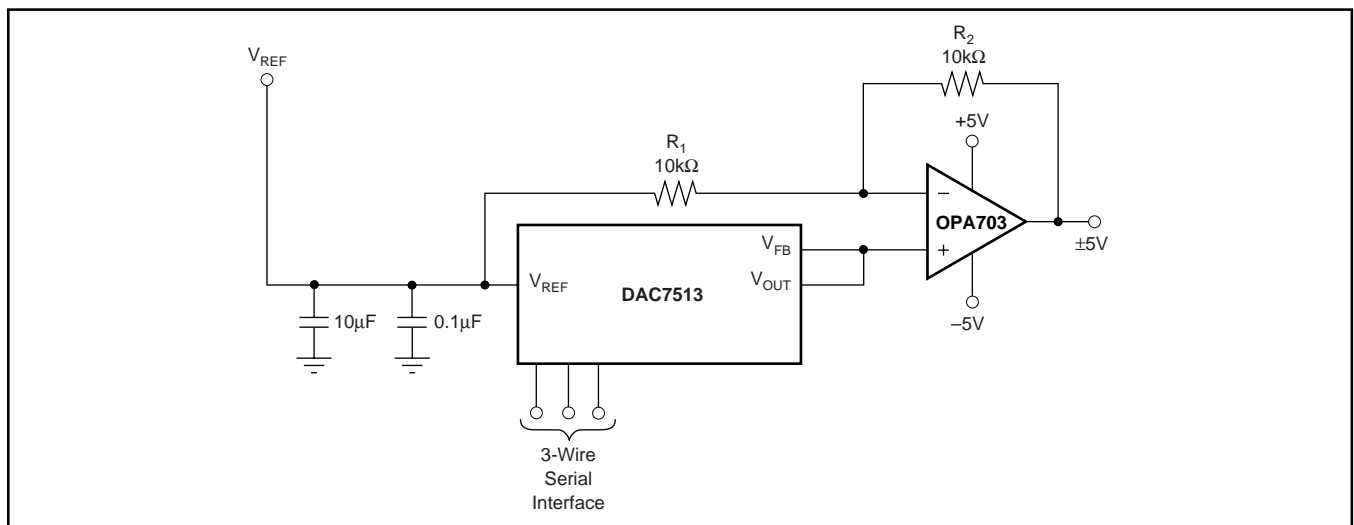
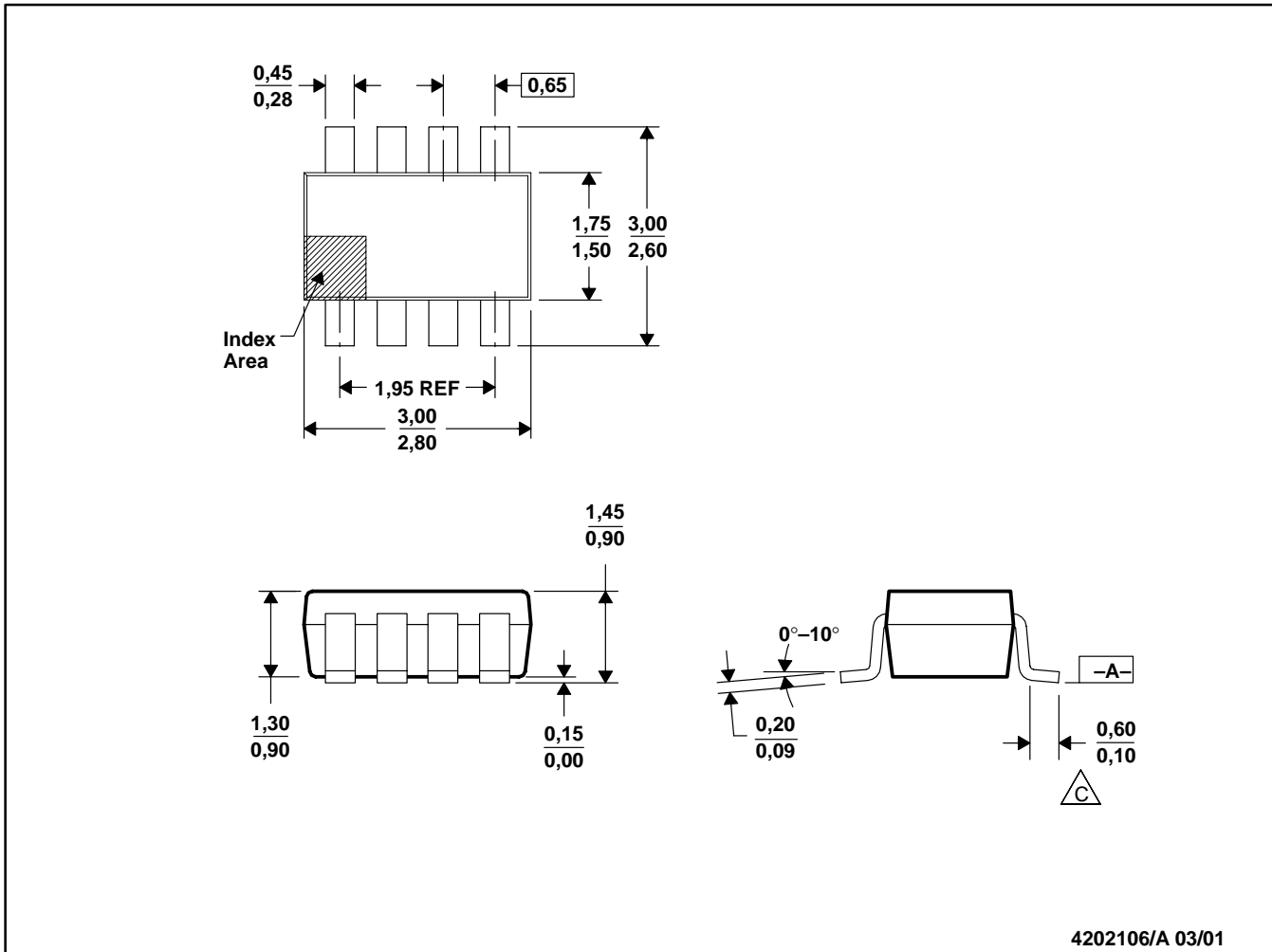



FIGURE 10. Bipolar Operation with the DAC7513.

The power applied to  $V_{DD}$  should be well regulated and low noise. Switching power supplies and DC/DC converters will often have high-frequency glitches or spikes riding on the output voltage. In addition, digital components can create similar high-frequency spikes as their internal logic switches states; this noise can easily couple into the DAC output voltage through various paths between the power connections and analog output. This is only true for the DAC7513 if the power supply is also opted to be used as the source of reference voltage for the DAC.

As with the GND connection,  $V_{DD}$  should be connected to a +5V power-supply plane or trace that is separate from the connection for digital logic until they are connected at the power-entry point. In addition, the 1 $\mu$ F to 10 $\mu$ F and 0.1 $\mu$ F bypass capacitors are strongly recommended. In some situations, additional bypassing may be required, such as a 100 $\mu$ F electrolytic capacitor or even a *Pi* filter made up of inductors and capacitors—all designed to essentially low-pass filter the +5V supply, removing the high-frequency noise.





- NOTES:
- A. All linear dimensions are in millimeters.
  - B. This drawing is subject to change without notice.
  -  C. Foot length measured reference to flat foot surface parallel to Datum A.
  - D. Package outline exclusive of mold flash, metal burr and dambar protrusion/intrusion.
  - E. Package outline inclusive of solder plating.
  - F. A visual index feature must be located within the cross-hatched area.

**PACKAGING INFORMATION**

Orderable Device	Status (1)	Package Type	Package Drawing	Pins	Package Qty	Eco Plan (2)	Lead/Ball Finish	MSL Peak Temp (3)	Op Temp (°C)	Top-Side Markings (4)	Samples
DAC7513E/250	ACTIVE	VSSOP	DGK	8	250	Green (RoHS & no Sb/Br)	CU NIPDAUAG	Level-2-260C-1 YEAR	-40 to 105	D13E	<a href="#">Samples</a>
DAC7513E/250G4	ACTIVE	VSSOP	DGK	8	250	Green (RoHS & no Sb/Br)	CU NIPDAUAG	Level-2-260C-1 YEAR	-40 to 105	D13E	<a href="#">Samples</a>
DAC7513E/2K5	ACTIVE	VSSOP	DGK	8	2500	Green (RoHS & no Sb/Br)	CU NIPDAUAG	Level-2-260C-1 YEAR	-40 to 105	D13E	<a href="#">Samples</a>
DAC7513E/2K5G4	ACTIVE	VSSOP	DGK	8	2500	Green (RoHS & no Sb/Br)	CU NIPDAUAG	Level-2-260C-1 YEAR	-40 to 105	D13E	<a href="#">Samples</a>
DAC7513N/250	ACTIVE	SOT-23	DCN	8	250	Green (RoHS & no Sb/Br)	CU NIPDAU	Level-1-260C-UNLIM	-40 to 105	D13N	<a href="#">Samples</a>
DAC7513N/250G4	ACTIVE	SOT-23	DCN	8	250	Green (RoHS & no Sb/Br)	CU NIPDAU	Level-1-260C-UNLIM	-40 to 105	D13N	<a href="#">Samples</a>
DAC7513N/3K	ACTIVE	SOT-23	DCN	8	3000	Green (RoHS & no Sb/Br)	CU NIPDAU	Level-1-260C-UNLIM	-40 to 105	D13N	<a href="#">Samples</a>
DAC7513N/3KG4	ACTIVE	SOT-23	DCN	8	3000	Green (RoHS & no Sb/Br)	CU NIPDAU	Level-1-260C-UNLIM	-40 to 105	D13N	<a href="#">Samples</a>

(1) The marketing status values are defined as follows:

**ACTIVE:** Product device recommended for new designs.

**LIFEBUY:** TI has announced that the device will be discontinued, and a lifetime-buy period is in effect.

**NRND:** Not recommended for new designs. Device is in production to support existing customers, but TI does not recommend using this part in a new design.

**PREVIEW:** Device has been announced but is not in production. Samples may or may not be available.

**OBSOLETE:** TI has discontinued the production of the device.

(2) Eco Plan - The planned eco-friendly classification: Pb-Free (RoHS), Pb-Free (RoHS Exempt), or Green (RoHS & no Sb/Br) - please check <http://www.ti.com/productcontent> for the latest availability information and additional product content details.

**TBD:** The Pb-Free/Green conversion plan has not been defined.

**Pb-Free (RoHS):** TI's terms "Lead-Free" or "Pb-Free" mean semiconductor products that are compatible with the current RoHS requirements for all 6 substances, including the requirement that lead not exceed 0.1% by weight in homogeneous materials. Where designed to be soldered at high temperatures, TI Pb-Free products are suitable for use in specified lead-free processes.

**Pb-Free (RoHS Exempt):** This component has a RoHS exemption for either 1) lead-based flip-chip solder bumps used between the die and package, or 2) lead-based die adhesive used between the die and leadframe. The component is otherwise considered Pb-Free (RoHS compatible) as defined above.

**Green (RoHS & no Sb/Br):** TI defines "Green" to mean Pb-Free (RoHS compatible), and free of Bromine (Br) and Antimony (Sb) based flame retardants (Br or Sb do not exceed 0.1% by weight in homogeneous material)

(3) MSL, Peak Temp. -- The Moisture Sensitivity Level rating according to the JEDEC industry standard classifications, and peak solder temperature.

<sup>(4)</sup> Multiple Top-Side Markings will be inside parentheses. Only one Top-Side Marking contained in parentheses and separated by a "~" will appear on a device. If a line is indented then it is a continuation of the previous line and the two combined represent the entire Top-Side Marking for that device.

**Important Information and Disclaimer:** The information provided on this page represents TI's knowledge and belief as of the date that it is provided. TI bases its knowledge and belief on information provided by third parties, and makes no representation or warranty as to the accuracy of such information. Efforts are underway to better integrate information from third parties. TI has taken and continues to take reasonable steps to provide representative and accurate information but may not have conducted destructive testing or chemical analysis on incoming materials and chemicals. TI and TI suppliers consider certain information to be proprietary, and thus CAS numbers and other limited information may not be available for release.

In no event shall TI's liability arising out of such information exceed the total purchase price of the TI part(s) at issue in this document sold by TI to Customer on an annual basis.

## TAPE AND REEL INFORMATION



### QUADRANT ASSIGNMENTS FOR PIN 1 ORIENTATION IN TAPE



\*All dimensions are nominal

Device	Package Type	Package Drawing	Pins	SPQ	Reel Diameter (mm)	Reel Width W1 (mm)	A0 (mm)	B0 (mm)	K0 (mm)	P1 (mm)	W (mm)	Pin1 Quadrant
DAC7513E/250	VSSOP	DGK	8	250	180.0	12.4	5.3	3.4	1.4	8.0	12.0	Q1
DAC7513E/2K5	VSSOP	DGK	8	2500	330.0	12.4	5.3	3.4	1.4	8.0	12.0	Q1

## TAPE AND REEL BOX DIMENSIONS



\*All dimensions are nominal

Device	Package Type	Package Drawing	Pins	SPQ	Length (mm)	Width (mm)	Height (mm)
DAC7513E/250	VSSOP	DGK	8	250	210.0	185.0	35.0
DAC7513E/2K5	VSSOP	DGK	8	2500	367.0	367.0	35.0

DCN (R-PDSO-G8)

PLASTIC SMALL-OUTLINE PACKAGE (DIE DOWN)

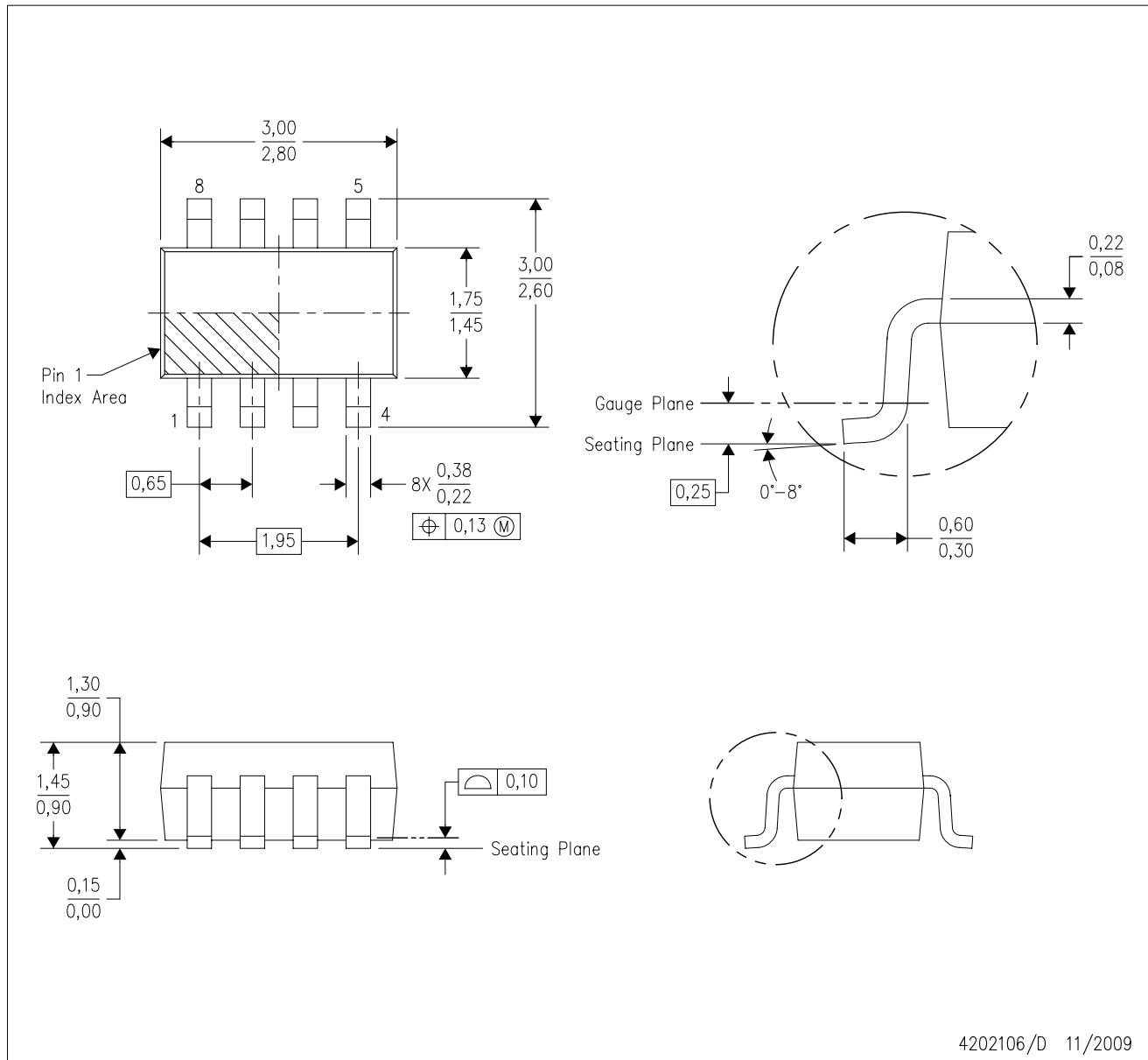

- NOTES:
- All linear dimensions are in millimeters.
  - This drawing is subject to change without notice.
  - Package outline exclusive of metal burr & dambar protrusion/intrusion.
  - Package outline inclusive of solder plating.
  - A visual index feature must be located within the Pin 1 index area.
  - Falls within JEDEC MO-178 Variation BA.
  - Body dimensions do not include flash or protrusion. Mold flash and protrusion shall not exceed 0.25 per side.

DCN (R-PDSO-G8)

PLASTIC SMALL-OUTLINE PACKAGE (DIE DOWN)



- NOTES:
- A. All linear dimensions are in millimeters.
  - B. This drawing is subject to change without notice.
  - C. Publication IPC-7351 is recommended for alternate designs.
  - D. Laser cutting apertures with trapezoidal walls and also rounding corners will offer better paste release. Customers should contact their board assembly site for stencil design recommendations. Refer to IPC-7525.
  - E. Customers should contact their board fabrication site for solder mask tolerances between and around signal pads.

DGK (S-PDSO-G8)

PLASTIC SMALL-OUTLINE PACKAGE



- NOTES:
- A. All linear dimensions are in millimeters.
  - B. This drawing is subject to change without notice.
  - C. Body length does not include mold flash, protrusions, or gate burrs. Mold flash, protrusions, or gate burrs shall not exceed 0.15 per end.
  - D. Body width does not include interlead flash. Interlead flash shall not exceed 0.50 per side.
  - E. Falls within JEDEC MO-187 variation AA, except interlead flash.



- NOTES:
- A. All linear dimensions are in millimeters.
  - B. This drawing is subject to change without notice.
  - C. Publication IPC-7351 is recommended for alternate designs.
  - D. Laser cutting apertures with trapezoidal walls and also rounding corners will offer better paste release. Customers should contact their board assembly site for stencil design recommendations. Refer to IPC-7525 for other stencil recommendations.
  - E. Customers should contact their board fabrication site for solder mask tolerances between and around signal pads.

## IMPORTANT NOTICE

Texas Instruments Incorporated (TI) reserves the right to make corrections, enhancements, improvements and other changes to its semiconductor products and services per JESD46, latest issue, and to discontinue any product or service per JESD48, latest issue. Buyers should obtain the latest relevant information before placing orders and should verify that such information is current and complete.

TI's published terms of sale for semiconductor products (<http://www.ti.com/sc/docs/stdterms.htm>) apply to the sale of packaged integrated circuit products that TI has qualified and released to market. Additional terms may apply to the use or sale of other types of TI products and services.

Reproduction of significant portions of TI information in TI data sheets is permissible only if reproduction is without alteration and is accompanied by all associated warranties, conditions, limitations, and notices. TI is not responsible or liable for such reproduced documentation. Information of third parties may be subject to additional restrictions. Resale of TI products or services with statements different from or beyond the parameters stated by TI for that product or service voids all express and any implied warranties for the associated TI product or service and is an unfair and deceptive business practice. TI is not responsible or liable for any such statements.

Buyers and others who are developing systems that incorporate TI products (collectively, "Designers") understand and agree that Designers remain responsible for using their independent analysis, evaluation and judgment in designing their applications and that Designers have full and exclusive responsibility to assure the safety of Designers' applications and compliance of their applications (and of all TI products used in or for Designers' applications) with all applicable regulations, laws and other applicable requirements. Designer represents that, with respect to their applications, Designer has all the necessary expertise to create and implement safeguards that (1) anticipate dangerous consequences of failures, (2) monitor failures and their consequences, and (3) lessen the likelihood of failures that might cause harm and take appropriate actions. Designer agrees that prior to using or distributing any applications that include TI products, Designer will thoroughly test such applications and the functionality of such TI products as used in such applications.

TI's provision of technical, application or other design advice, quality characterization, reliability data or other services or information, including, but not limited to, reference designs and materials relating to evaluation modules, (collectively, "TI Resources") are intended to assist designers who are developing applications that incorporate TI products; by downloading, accessing or using TI Resources in any way, Designer (individually or, if Designer is acting on behalf of a company, Designer's company) agrees to use any particular TI Resource solely for this purpose and subject to the terms of this Notice.

TI's provision of TI Resources does not expand or otherwise alter TI's applicable published warranties or warranty disclaimers for TI products, and no additional obligations or liabilities arise from TI providing such TI Resources. TI reserves the right to make corrections, enhancements, improvements and other changes to its TI Resources. TI has not conducted any testing other than that specifically described in the published documentation for a particular TI Resource.

Designer is authorized to use, copy and modify any individual TI Resource only in connection with the development of applications that include the TI product(s) identified in such TI Resource. NO OTHER LICENSE, EXPRESS OR IMPLIED, BY ESTOPPEL OR OTHERWISE TO ANY OTHER TI INTELLECTUAL PROPERTY RIGHT, AND NO LICENSE TO ANY TECHNOLOGY OR INTELLECTUAL PROPERTY RIGHT OF TI OR ANY THIRD PARTY IS GRANTED HEREIN, including but not limited to any patent right, copyright, mask work right, or other intellectual property right relating to any combination, machine, or process in which TI products or services are used. Information regarding or referencing third-party products or services does not constitute a license to use such products or services, or a warranty or endorsement thereof. Use of TI Resources may require a license from a third party under the patents or other intellectual property of the third party, or a license from TI under the patents or other intellectual property of TI.

TI RESOURCES ARE PROVIDED "AS IS" AND WITH ALL FAULTS. TI DISCLAIMS ALL OTHER WARRANTIES OR REPRESENTATIONS, EXPRESS OR IMPLIED, REGARDING RESOURCES OR USE THEREOF, INCLUDING BUT NOT LIMITED TO ACCURACY OR COMPLETENESS, TITLE, ANY EPIDEMIC FAILURE WARRANTY AND ANY IMPLIED WARRANTIES OF MERCHANTABILITY, FITNESS FOR A PARTICULAR PURPOSE, AND NON-INFRINGEMENT OF ANY THIRD PARTY INTELLECTUAL PROPERTY RIGHTS. TI SHALL NOT BE LIABLE FOR AND SHALL NOT DEFEND OR INDEMNIFY DESIGNER AGAINST ANY CLAIM, INCLUDING BUT NOT LIMITED TO ANY INFRINGEMENT CLAIM THAT RELATES TO OR IS BASED ON ANY COMBINATION OF PRODUCTS EVEN IF DESCRIBED IN TI RESOURCES OR OTHERWISE. IN NO EVENT SHALL TI BE LIABLE FOR ANY ACTUAL, DIRECT, SPECIAL, COLLATERAL, INDIRECT, PUNITIVE, INCIDENTAL, CONSEQUENTIAL OR EXEMPLARY DAMAGES IN CONNECTION WITH OR ARISING OUT OF TI RESOURCES OR USE THEREOF, AND REGARDLESS OF WHETHER TI HAS BEEN ADVISED OF THE POSSIBILITY OF SUCH DAMAGES.

Unless TI has explicitly designated an individual product as meeting the requirements of a particular industry standard (e.g., ISO/TS 16949 and ISO 26262), TI is not responsible for any failure to meet such industry standard requirements.

Where TI specifically promotes products as facilitating functional safety or as compliant with industry functional safety standards, such products are intended to help enable customers to design and create their own applications that meet applicable functional safety standards and requirements. Using products in an application does not by itself establish any safety features in the application. Designers must ensure compliance with safety-related requirements and standards applicable to their applications. Designer may not use any TI products in life-critical medical equipment unless authorized officers of the parties have executed a special contract specifically governing such use. Life-critical medical equipment is medical equipment where failure of such equipment would cause serious bodily injury or death (e.g., life support, pacemakers, defibrillators, heart pumps, neurostimulators, and implantables). Such equipment includes, without limitation, all medical devices identified by the U.S. Food and Drug Administration as Class III devices and equivalent classifications outside the U.S.

TI may expressly designate certain products as completing a particular qualification (e.g., Q100, Military Grade, or Enhanced Product). Designers agree that it has the necessary expertise to select the product with the appropriate qualification designation for their applications and that proper product selection is at Designers' own risk. Designers are solely responsible for compliance with all legal and regulatory requirements in connection with such selection.

Designer will fully indemnify TI and its representatives against any damages, costs, losses, and/or liabilities arising out of Designer's non-compliance with the terms and provisions of this Notice.

## Looking for pricing, stock, or lifecycle information?

Click below to explore more details on WIN SOURCE:

 [View DAC7513N/3K on WIN SOURCE](#)

 [Texas Instruments](#) Information

## Optimize Your Supply Chain with WIN SOURCE Solutions

-  Global Sourcing Solution
-  Obsolete Management
-  Cost Control Management
-  Shortage Management
-  Alternative Solution
-  Excess Inventory Management