



**THE DATASHEET OF
TDA38820AUMA1**



TDA38820 OptiMOS™ IPOL

20 A single-voltage synchronous Buck regulator

Features

- Single 4.3 V to 17 V application or Wide Input Voltage Range from 2.0 V to 17 V with an External VCC
- Precision Reference Voltage (0.6 V +/- 0.5%)
- Enhanced Fast COT engine stable with Ceramic Output Capacitors and No External Compensation
- Optional Forced Continuous Conduction Mode and Diode Emulation for Enhanced Light Load Efficiency
- Programmable Switching Frequency from 600 kHz to 2 MHz
- Monotonic Start-Up with Four Selectable Soft-Start Time & Enhanced Pre-Bias Start-Up
- Thermally Compensated Internal Over Current Protection with Four Selectable Settings
- Enable input with Voltage Monitoring Capability & Power Good Output
- Thermal Shut Down
- Operating Temp: $-40\text{ °C} < T_j < 125\text{ °C}$
- Small Size: 4 mm x 5 mm PQFN
- Halogen-free and RoHS2 Compliant with Exemption 7a

Potential applications

- Server Applications
- Storage Applications
- Telecom & Datacom Applications
- Distributed Point of Load Power Architectures

Product validation

Qualified for industrial applications according to the relevant tests of JEDEC47/20/22

Description

The TDA38820 is an easy-to-use, fully integrated dc - dc Buck regulator. The onboard PWM controller and OptiMOS™ FETs with integrated bootstrap diode make TDA38820 a small footprint solution, providing high-efficient power delivery. Furthermore, it uses a fast Constant On-Time (COT) control scheme, which simplifies the design efforts and achieves fast control response.

The TDA38820 has an internal low dropout voltage regulator, allowing operations with a single supply. It can also operate with an external bias supply, extending the operating input voltage (P_{Vin}) range from 2.0 V to 17 V.

The TDA38820 is a versatile regulator, offering programmable switching frequency from 600 kHz to 2 MHz, four selectable current limits, four selectable soft-start time, Forced Continuous Conduction Mode (FCCM) and Diode Emulation Mode (DEM) operation.

It also features important protection functions, such as pre-bias start-up, thermally compensated current limit, over voltage and under voltage protection, and thermal shutdown to give required system level security in the event of fault conditions.

Table of contents

Features 1

Potential applications 1

Product validation 1

Description 1

Table of contents 2

1 Ordering information 4

2 Functional block diagram 5

3 Typical application diagram 6

4 Pin descriptions 7

5 Absolute maximum ratings 9

6 Thermal Characteristics 10

6.1 Thermal Characteristics 10

7 Electrical specifications 11

7.1 Recommended operating conditions 11

7.2 Electrical characteristics 12

8 Typical efficiency and power loss curves 15

8.1 P_{Vin} = V_{in} = 12 V, f_{sw} = 600 kHz 15

8.2 P_{Vin} = V_{in} = 12 V, f_{sw} = 800 kHz 16

8.3 P_{Vin} = V_{in} = 12 V, f_{sw} = 1000 kHz 17

8.4 P_{Vin} = V_{in} = V_{CC} = 5 V, f_{sw} = 600 kHz 18

9 Typical operating characteristics (-40 °C ≤ T_j ≤ +125 °C) 19

10 Thermal De-rating curves 22

11 R_{DS(ON)} of MOSFET Over Temperature 23

12 Theory of operation 24

12.1 Fast Constant On-Time Control 24

12.2 Enable 24

12.3 FCCM and DEM Operation 25

12.4 Pseudo Constant Switching Frequency 25

12.5 Soft-start 26

12.6 Pre-bias Start-up 27

12.7 Internal Low - Dropout (LDO) Regulator 27

12.8 Over Current Protection (OCP) 28

12.9 Under Voltage Protection (UVP) 29

12.10 Over Voltage Protection (OVP) 29

12.11 Over Temperature Protection (OTP) 30

12.12 Power Good (PGood) Output 30

12.13 Minimum On - Time and Minimum Off - Time 31

12.14 Selection of Feedforward Capacitor and Feedback Resistors 31

12.15 Resistors for Configuration Pins 32

13 Design example 33

13.1 Enabling the TDA38820 33

13.2 Programming the Switching Frequency and Operation Mode 33

13.3 Selecting Input Capacitors 33

13.4 Inductor Selection 34

Table of contents

13.5	Output Capacitor Selection	34
13.6	Output Voltage Programming.....	35
13.7	Feedforward Capacitor	35
13.8	Bootstrap Capacitor	35
13.9	VIN, and VCC/LDO bypass Capacitor	35
14	Application Information.....	36
14.1	Application Diagram.....	36
14.2	Typical Operating Waveforms.....	36
15	Layout Recommendations.....	39
15.1	Solder Mask	43
15.2	Stencil Design	44
16	Package	45
16.1	Marking Information	45
16.2	Dimensions	45
16.3	Tape and Reel Information	47
17	Environmental Qualifications	48
18	Evaluation Boards and Support Documentation	49
	Revision history.....	50

Ordering information

1 Ordering information

1. Ordering Information

Sales Product Name	Package Type	Standard Pack Form and Qty		Orderable Part Number
TDA38820	QFN 4 mm x 5 mm	Tape and Reel	5000	TDA38820AUMA1

Packing type	Tape & Reel
Moisture protection packing	Dry
Packing size	330 mm

Halogen Free	Yes
RoHS compliant	Yes
Total lead free	No

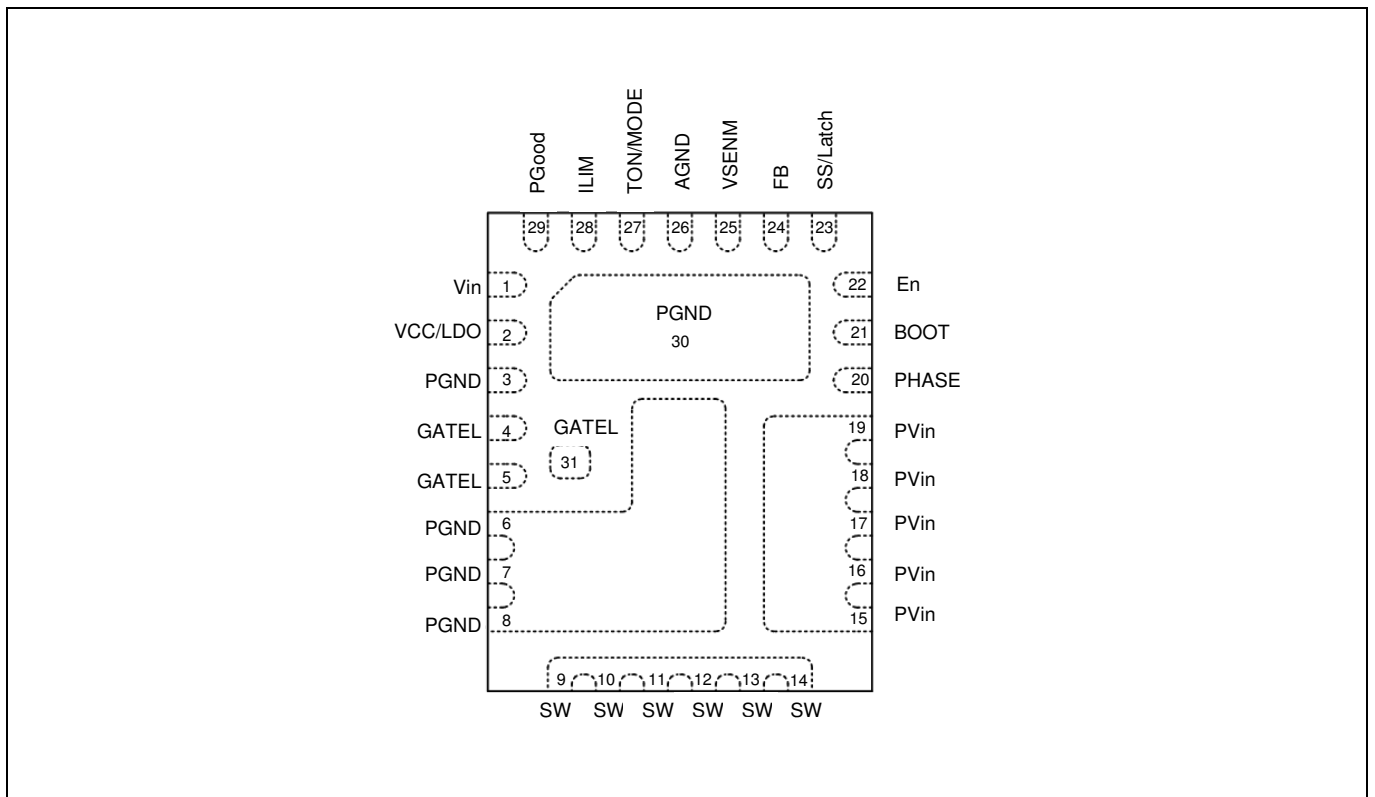

Figure 1 Package Top View

2 Functional block diagram

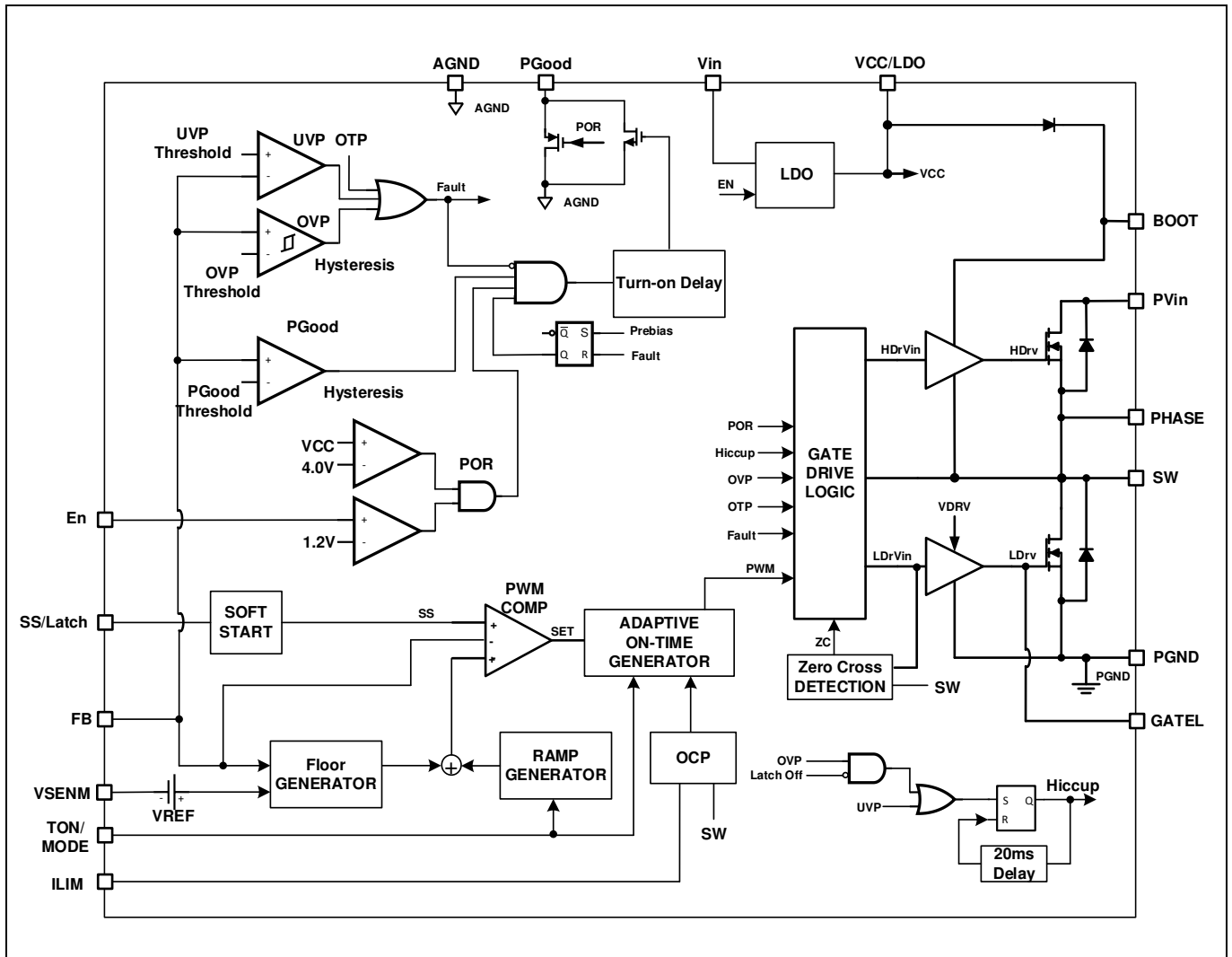

Figure 2 Block diagram

3 Typical application diagram

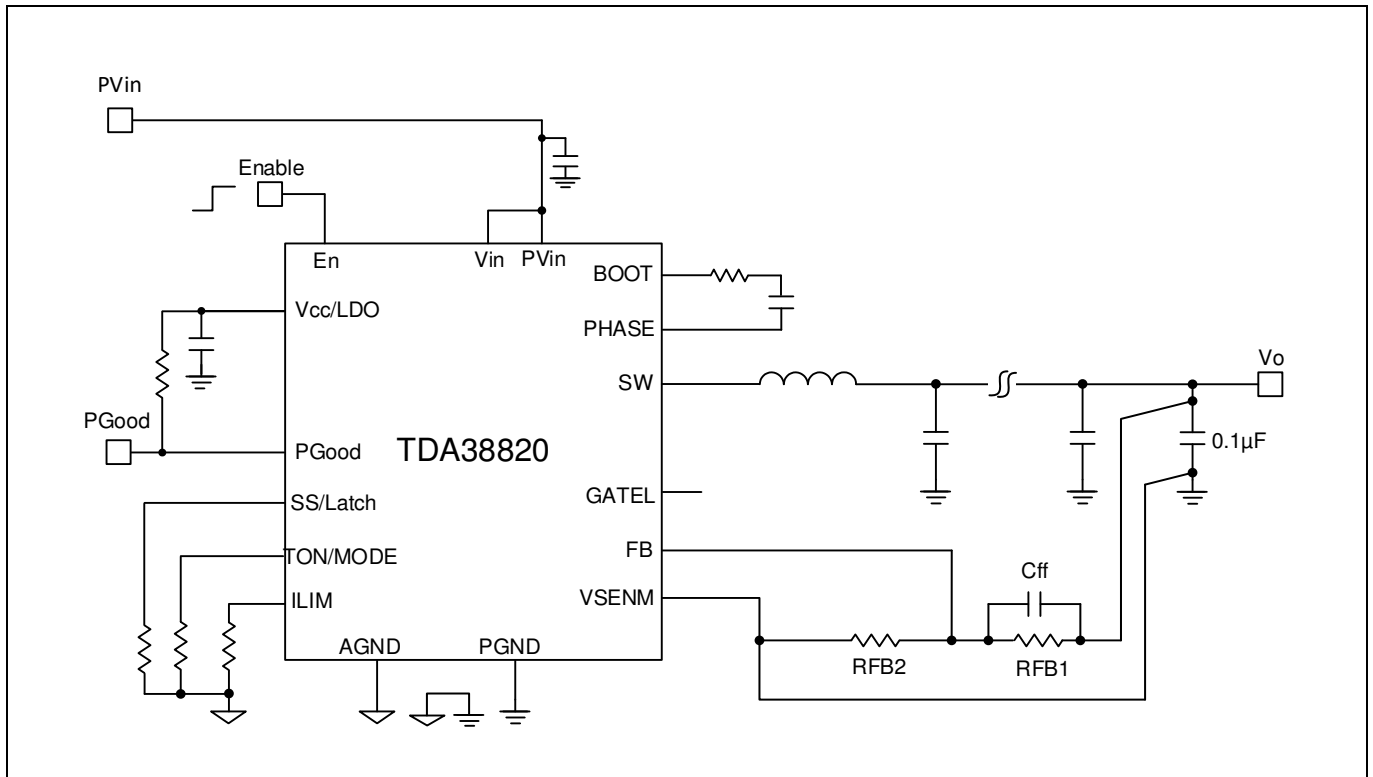

Figure 3 TDA38820 basic application circuit

Pin descriptions

4 Pin descriptions

Note: I = Input, O = Output

Pin#	Pin Name	I/O	Type	Pin Description
1	VIN	I	Power	Input voltage for an Internal LDO. A 4.7 μ F capacitor should be connected between this pin and PGnd. If an external supply is connected to VCC/LDO pin, this pin should be shorted to VCC/LDO pin and a 10 μ F ceramic capacitor can be shared with Vin and VCC/LDO pin.
2	VCC/LDO	I/O	Power	Input bias for an external VCC voltage or output of the internal LDO. A 2.2 μ F - 10 μ F ceramic capacitor is recommended to use between VCC and the Power ground (PGND).
3, 6, 7, 8, 30	PGND	-	Ground	Power Ground. Should be connected to the system's power ground plane. PGND and AGND are internally connected via the lead frame.
4, 5, 31	GATEL	I	Analog	Gate of Low-side FET. The signal on this pin is used for test purposes and must not have external components connected to it.
9, 10, 11, 12, 13, 14	SW	O	Power	Switch Node. Connect these pins to an output inductor.
15, 16, 17, 18, 19	PVin	I	Power	Input supply for the power stage.
20	Phase	O	Analog	Source of High-side FET. Connect a bootstrap capacitor between this pin and Boot pin. A high temperature (X7R) 0.1 μ F or greater value ceramic capacitor is recommended.
21	Boot	I	Analog	Supply voltage for the high side driver. Connect this pin to the Phase pin through a bootstrap capacitor. A resistor can be placed in series with the bootstrap capacitor to control the slew rate of the SW node rising edge.
22	EN	I	Analog	Multi-function pin: (1) Enable pin to turn the device on and off; (2) enable or disable the internal LDO; (3) , If this pin is connected to PVin pin through a resistor divider, input voltage UVLO can be implemented.
23	SS/Latch	I	Analog	Multi-function pin. Connect this pin to GND with a resistor to select Soft-Start time from 4 options. This pin also selects latched-off Over Voltage Protection (OVP) or non-latched OVP.
24	FB	I	Analog	Output voltage feedback pin. Connect this pin to the output of the regulator via a resistor divider to set the output voltage.
25	VSENM	-	Analog	This pin provides the return connection for a pseudo remote voltage sensing. The feedback resistor divider should be connected to this pin. It is also used as ground for the internal reference voltage.
26	AGND	-	Ground	Signal ground for the internal circuitry except the internal reference voltage.

TDA38820 OptiMOS™ IPOL

20 A single-voltage synchronous Buck regulator



Pin descriptions

Pin#	Pin Name	I/O	Type	Pin Description
27	MODE/TON	I	Analog	Multi-function pin. This pin sets the switching frequency to 1 of 8 settings and sets the mode of operation to FCCM or DEM by connecting a resistor to ground.
28	ILIM	I	Analog	Connecting a resistor to ground sets the Over Current Protection (OCP) limit. Four user selectable OCP limits are available.
29	PGood	O	Analog	Power Good status output pin is open drain. Connect a pull up resistor from this pin to VCC or to an external bias voltage, e.g. a 50 kΩ pull-up resistor for a PGood bias voltage of 3.3 V.

Absolute maximum ratings

5 Absolute maximum ratings

Absolute maximum ratings

Description	Min	Max	Unit	Conditions
PVin, Vin, En to PGND	-0.3	25	V	Note 1
PVin to SW and PHASE	-0.3 V(dc) , below -5 V for 5 ns	25 V(dc), above 32 V for 2 ns	V	
VCC to PGND	-0.3	6	V	Note 1
Boot to PGND	-0.3 V(dc), below -0.3 V for 5 ns	29	V	Note 1
SW and PHASE to PGND	-0.3 (dc), below -5 V for 5 ns	25 V(dc), above 32 V for 2 ns	V	Note 1
Boot to PHASE	-0.3	6 V(dc), 7 V for 5 ns	V	
ILIM, Fb, PGood, TON, GATEL and SS to GND	-0.3	6	V	Note 1
PGnd to AGND	-0.3	0.3	V	
VSENM to AGND	-0.3	0.3	V	
Storage Temperature Range	-55	150	°C	
Junction Temperature Range	-40	150	°C	

Note:

1. PGND, VSENM, and AGND pin are connected together

Attention: *Stresses beyond these listed under “Absolute Maximum Ratings” may cause permanent damage to the device. These are stress ratings only and functional operation of the device at these or any other conditions beyond those indicated in the operational sections of the specifications are not implied.*

6 Thermal Characteristics

6.1 Thermal Characteristics

Description	Symbol	Values	Test Conditions
Junction to Ambient Thermal Resistance	θ_{JA}	15 °C/W	Note 2
Junction to PCB Thermal Resistance	θ_{JC-PCB}	1 °C/W	Note 3
Junction to Case Top Thermal Resistance	θ_{JC}	22 °C/W	

Note:

2. Thermal resistance is measured with components mounted on a standard EVAL_38820_1Vout demo board in free air.
3. Thermal resistance is based on the board temperature near the pin 17.

7 Electrical specifications

7.1 Recommended operating conditions

Description	Min	Max	Unit	Note
PVin Voltage Range with External VCC	2	17	V	Note 4, Note 5
PVin Voltage Range with Internal LDO	4.5	17	V	Note 5, Note 6 & 10
VCC Supply Voltage Range	4.3	5.5	V	Note 4, Note 7
Typical Output Voltage Range	0.6	6	V	Note 8, Note 9
Continuous Output Current Range		20	A	Note 9
Typical Switching Frequency	600	2000	kHz	Note 10
Operating Junction Temperature	-40	125	°C	

Note:

4. *V_{in} is shorted to VCC and use an external bias voltage.*
5. *A common practice is to have 20% margin on the maximum SW node voltage in the design. For applications requiring PVin equal to or above 14 V, a small resistor in series with the Boot pin might be needed to ensure the maximum SW node spike voltage does not exceed 20 V. Alternatively, a snubber can be used at the SW node to reduce the SW node spike.*
6. *V_{in} is connected to PVin and the internal LDO is used. For single-rail applications with the internal LDO and PVin = V_{in} = 4.3 V-5.4 V, the internal LDO may enter dropout mode. OCP limits can be reduced due to the lower VCC voltage. Please refer to [Section 12.7](#) for more detailed design guidelines.*
7. *The TDA38820 is designed to function with VCC down to 4.2 V, however, electrical specifications such as OCP limits may be degraded.*
8. *The maximum output voltage is limited by the minimum off-time. Please refer to [Section 12.13](#) for details. Also note that OCP limit may be degraded when off-time is close to the minimum off-time.*
9. *Maximum output current capability can be reduced at elevated ambient temperatures.*
10. *The maximum LDO output current must be limited within 50 mA for operations requiring full operating temperature range of -40 °C ≤ T_J ≤ 125 °C. [Figure 4](#) shows the maximum LDO output current capability over junction temperature. Thermal de-rating may be needed at an elevated ambient temperature to ensure the junction temperature within the recommended operating range.*

Electrical specifications

7.2 Electrical characteristics

Note: Unless otherwise specified, the specifications apply over, $4.5\text{ V} \leq V_{in} = P_{Vin} \leq 17\text{ V}$, $0\text{ }^\circ\text{C} < T_j < 125\text{ }^\circ\text{C}$. Typical values are specified at $T_a = 25\text{ }^\circ\text{C}$.

Parameter	Symbol	Conditions	Min	Typ	Max	Unit
Power Stage						
Top Switch	$R_{ds(on)_Top}$	$V_{Boot} - V_{sw} = 5.0\text{ V}$, $I_o = 20\text{ A}$, $T_j = 25\text{ }^\circ\text{C}$		2.4		m Ω
Bottom Switch	$R_{ds(on)_Bot}$	$V_{CC} = 5.0\text{ V}$, $I_o = 20\text{ A}$, $T_j = 25\text{ }^\circ\text{C}$		1.98		
Bootstrap Forward Voltage		$I(\text{Boot}) = 25\text{ mA}$		365	600	mV
SW float voltage	V_{sw}	EN = 0 V			300	mV
		EN = high, No Switching			300	
Dead Band Time	T_{db}	SW node rising edge, $I_o = 20\text{ A}$, Internal LDO, $T_j = 25\text{ }^\circ\text{C}$, Note 11		9		ns
		SW node falling edge, $I_o = 20\text{ A}$, Internal LDO, $T_j = 25\text{ }^\circ\text{C}$, Note 11		9		ns
Supply Current						
Vin Supply Current (standby)	$I_{in(\text{Standby})}$	EN = Low, No Switching		2.7	10	μA
Vin Supply Current (static)	$I_{in(\text{Static})}$	EN=2 V, No Switching		2.3	4	mA
Soft Start						
Soft Start Ramp Rate	SS rate	SS/Latch = 0 k Ω , 4.53 k Ω , 10.5 k Ω , 18.7 k Ω ;	0.4	0.6	0.84	mV/ μs
		SS/Latch = 1.5 k Ω , 5.76 k Ω , 12.1 k Ω , 21.5 k Ω ;	0.2	0.3	0.42	
		SS/Latch = 2.49 k Ω , 7.32 k Ω , 14 k Ω , 24.9 k Ω ; floating	0.1	0.15	0.21	
		SS/Latch = 3.48 k Ω , 8.87 k Ω , 16.2 k Ω , 28.7 k Ω ;	0.05	0.075	0.105	
Feedback Voltage						
Feedback Voltage	V_{FB}			0.6		V
Accuracy		$0\text{ }^\circ\text{C} < T_j < 85\text{ }^\circ\text{C}$	-0.5		+0.5	%
		$-40\text{ }^\circ\text{C} < T_j < 125\text{ }^\circ\text{C}$, Note 12	-1		1	
V_{FB} Input Current	$I_{V_{FB}}$	$V_{FB} = 0.6\text{ V}$, $T_j = 25\text{ }^\circ\text{C}$	-150	0	+150	nA
On-Time Timer Control						
On Time	T_{on}	$V_{in} = 12\text{ V}$, $V_o = 1\text{ V}$, TON= 0 k Ω , 10.5 k Ω , Note 13		151		ns
		$V_{in} = 12\text{ V}$, $V_o = 1\text{ V}$, TON= 1.5 k Ω , 12.1 k Ω , Note 13		114		
		$V_{in} = 12\text{ V}$, $V_o = 1\text{ V}$, TON= 2.49 k Ω , 14 k Ω , Note 13 ;		91.5		
		$V_{in} = 12\text{ V}$, $V_o = 1\text{ V}$, TON= 3.48 k Ω , 16.2 k Ω , Note 13		77		

TDA38820 OptiMOS™ IPOL

20 A single-voltage synchronous Buck regulator



Electrical specifications

Parameter	Symbol	Conditions	Min	Typ	Max	Unit
		Vin=12 V, Vo=1 V, TON= 4.53 kΩ, 18.7 kΩ, Note 13		66.5		
		Vin=12 V, Vo=1 V, TON= 5.76 kΩ, 21.5 kΩ, Note 13		58.5		
		Vin=12 V, Vo=1 V, TON= 7.32 kΩ, 24.9 kΩ, Note 13		52		
		Vin=12V , Vo=1 V, TON= 8.87kΩ, 28.7kΩ, Note 13		47		
		Vin=12V, Vo=1.0V, TON = Floating, Note 13		114		
Minimum On-Time	T _{on (Min)}	Vin=12 V, Vo=0 V		23	32	ns
Minimum Off-Time	T _{off (Min)}	T _j =25 °C, V _{FB} =0 V		270	360	ns
VCC LDO Output						
Output Voltage	VCC	5.5 V ≤ Vin ≤ 17 V, when I _{cc} =50 mA, C _{load} = 2.2 μF	4.7	5.0	5.3	V
VCC Dropout	VCC_drop	Vin = 4.3 V, I _{cc} =50 mA, C _{load} =2.2 μF			300	mV
Short Circuit Current	I _{short}	5.5 V ≤ Vin ≤ 17 V		90		mA
Under Voltage Lockout						
VCC-Start Threshold	Vcc_UVLO_Start	VCC Rising Trip Level	3.8	4.0	4.2	V
VCC-Stop Threshold	Vcc_UVLO_Stop	VCC Falling Trip Level	3.6	3.8	4.0	
Enable-Start-Threshold	En_UVLO_Start	ramping up	1.14	1.2	1.36	V
Enable-Stop-Threshold	En_UVLO_Stop	ramping down	0.9	1	1.06	
Input Impedance	R _{EN}		500	1000	1500	kΩ
Over Current Limit						
Current Limit Threshold (Valley current)	I _{oc}	T _j = 25 °C, Int LDO, RILIM=24.9 kΩ, Note 14	20.7	26	29	A
		T _j = 25 °C, Int LDO, RILIM=21.5 kΩ, Note 14	16.9	21.6	24.1	
		T _j = 25 °C, Int LDO, RILIM=16.2 kΩ, Note 14	13.5	17	19.2	
		T _j = 25 °C, Int LDO, RILIM=12.1 kΩ, Note 14	10.1	13	14.4	
Over Voltage Protection						
OVP Trip Threshold	OVP_Vth	FB Rising	115	121	125	% V _{ref}
		FB Falling, OVP hysteresis	110	115	120	
OVP Protection Delay	OVP_Tdly			8		μs
Hiccup Blanking Time	T _{blk_Hiccup}	Unlatched OVP		20		ms
Under Voltage Protection						
UVP Trip Threshold	UVP_Vth	FB Falling	65	70	75	% V _{ref}
UVP Protection Delay	UVP_Tdly			2		μs

TDA38820 OptiMOS™ IPOL

20 A single-voltage synchronous Buck regulator



Electrical specifications

Parameter	Symbol	Conditions	Min	Typ	Max	Unit
Hiccup Blanking Time	Tblk_Hiccup			20		ms
Power Good						
Pgood Turn on Threshold	VPG(upper)	FB Rising	85	91	95	% Vref
Pgood Turn off Threshold	VPG(lower)	FB Falling	80	84	90	% Vref
Pgood Sink Current	I _{PG}	PG = 0.5 V, En = 2 V	2.5	5		mA
Pgood Voltage Low	V _{PG(low)}	Vin = VCC = 0 V, Rpull-up = 50 kΩ to 3.3 V		0.3	0.5	V
Pgood Turn on Delay	V _{PG(on)_Dly}	FB Rising, see VPG(upper)		2.5		ms
Pgood Comparator Delay	V _{PG(comp)_Dly}	VFB < VPG(lower) or VFB > VPG(upper)	1	2	3.5	μs
Pgood Open Drain Leakage Current		PG = 3.3 V			1	μA
Thermal Shutdown						
Thermal Shutdown		Note 11		140		°C
Hysteresis		Note 11		20		

Note:

11. Guaranteed by construction and not tested in production
12. Cold and hot temperature performance is guaranteed via correlation using statistical quality control. Not tested in production.
13. The Ton is trimmed so that the target switching frequency is achieved at around 10A load current using EVAL_38820_1Vout demo board.
14. The specified OCP limits refer to the valley of the inductor current when OCP is tripped. For more detailed design guideline, please refer to Section [12.8](#).

8 Typical efficiency and power loss curves

8.1 $P_{Vin} = V_{in} = 12\text{ V}$, $f_{sw} = 600\text{ kHz}$

$P_{Vin} = V_{in} = 12\text{ V}$, $V_{CC} = \text{Internal LDO}$, $I_o = 0\text{ A}-20\text{ A}$, $f_{sw} = 600\text{ kHz}$, Room Temperature, No Air Flow. Note that the efficiency and power loss curves include the losses of TDA38820, the inductor losses, the losses of the input and output capacitors, and PCB trace losses. The table below shows the inductors used for each of the output voltages in the efficiency measurement.

Table 1 Inductors for $P_{Vin} = V_{in} = 12\text{ V}$, $f_{sw} = 600\text{ kHz}$

Vout (V)	Lout (nH)	P/N	DCR (mΩ)	Size (mm)
1.0	215	HCB1075N-211 (Delta)	0.29	10.4 x 8 x 7.5
1.2	215	HCB1075N-211 (Delta)	0.29	10.4 x 8 x 7.5
1.8	350	HCBD101195-351 (Delta)	0.35	10.1 x 11.4 x 9.5
2.5	450	HCBD101195-451 (Delta)	0.35	10.1 x 11.4 x 9.5
3.3	450	HCBD101195-451 (Delta)	0.35	10.1 x 11.4 x 9.5
5	625	SLM534214A-R62MHF (ITG)	0.42	13.5 x 12.8 x 10.7

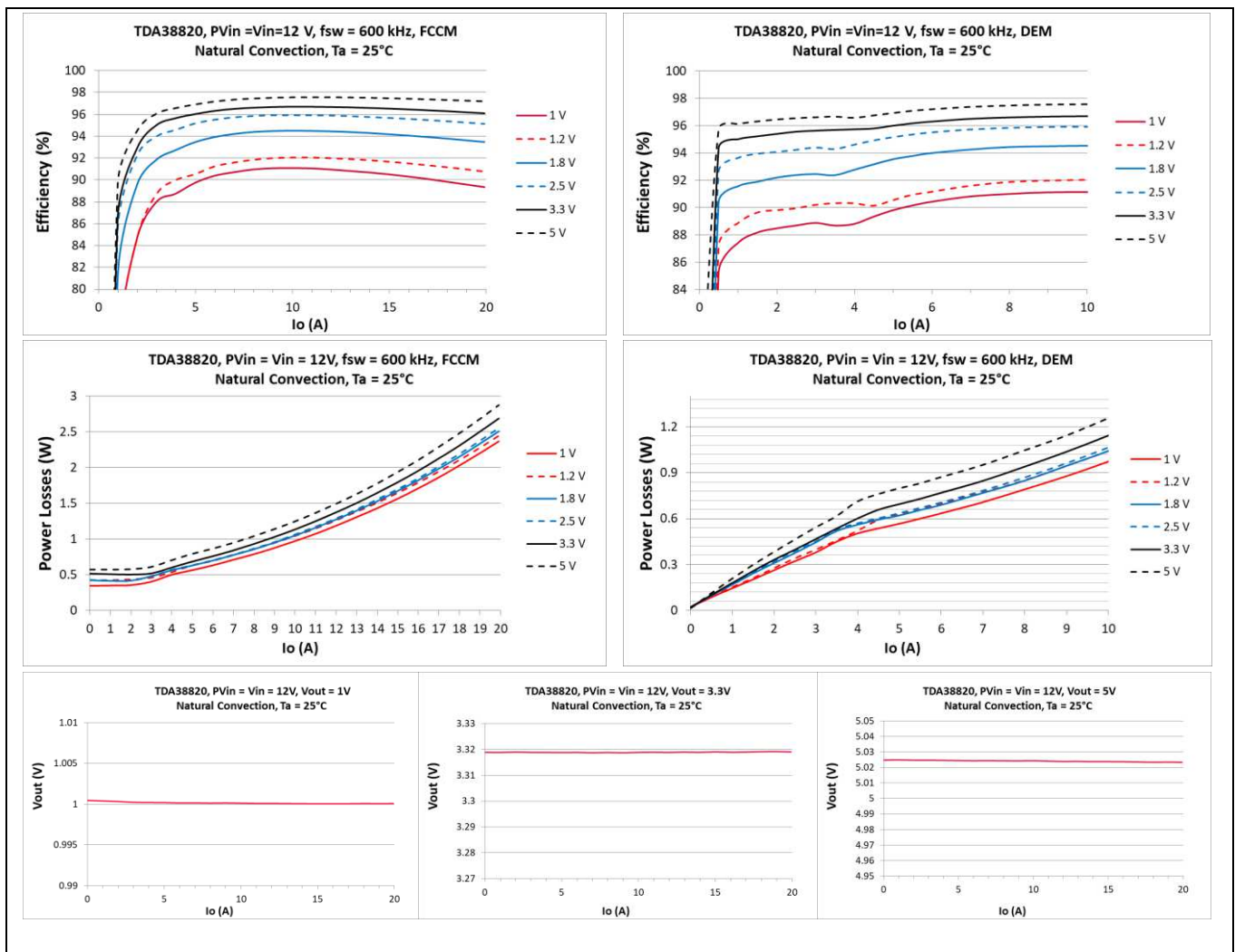

Typical efficiency and power loss curves

8.2 PVin = Vin = 12 V, fsw = 800 kHz

PVin = Vin = 12 V, VCC = Internal LDO, Io = 0 A-20 A, fsw = 800 kHz, Room Temperature, No Air Flow. Note that the efficiency and power loss curves include the losses of TDA38820, the inductor losses, the losses of the input and output capacitors, and PCB trace losses. The table below shows the inductors used for each of the output voltages in the efficiency measurement.

Table 2 Inductors for PVin = Vin = 12 V, fsw = 800 kHz

Vout (V)	Lout (nH)	P/N	DCR (mΩ)	Size (mm)
1.0	150	AH3740A-150K (ITG)	0.145	6.4x9.5x10
1.2	150	AH3740A-150K (ITG)	0.145	6.4x9.5x10
1.8	215	HCB1075N-211 (Delta)	0.29	10.4 x 8 x 7.5
2.5	350	HCBD101195-351 (Delta)	0.35	10.1 x 11.4 x 9.5
3.3	350	HCBD101195-351 (Delta)	0.35	10.1 x 11.4 x 9.5
5	450	HCBD101195-451 (Delta)	0.35	10.1 x 11.4 x 9.5

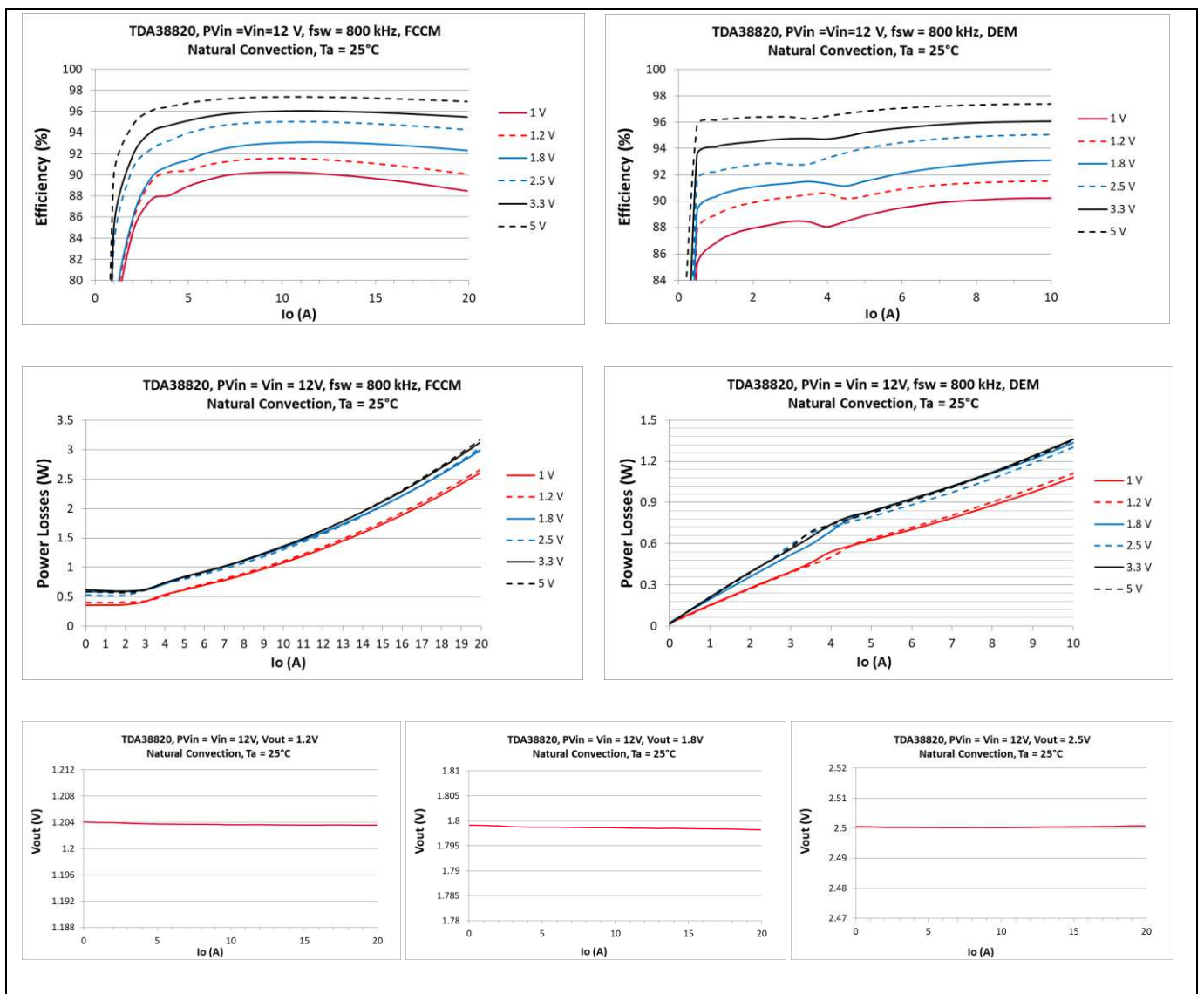

Typical efficiency and power loss curves

8.3 PVin = Vin = 12 V, fsw = 1000 kHz

PVin = Vin = 12 V, VCC = Internal LDO, Io = 0 A-20 A, fsw = 1000 kHz, Room Temperature, No Air Flow. Note that the efficiency and power loss curves include the losses of TDA38820, the inductor losses, the losses of the input and output capacitors, and PCB trace losses. The table below shows the inductors used for each of the output voltages in the efficiency measurement.

Table 3 Inductors for PVin = Vin = 12 V, fsw = 1000 kHz

Vout (V)	Lout (nH)	P/N	DCR (mΩ)	Size (mm)
1.0	150	AH3740A-150K (ITG)	0.145	6.4x9.5x10
1.2	150	AH3740A-150K (ITG)	0.145	6.4x9.5x10
1.8	215	HCB1075N-211 (Delta)	0.29	10.4 x 8 x 7.5

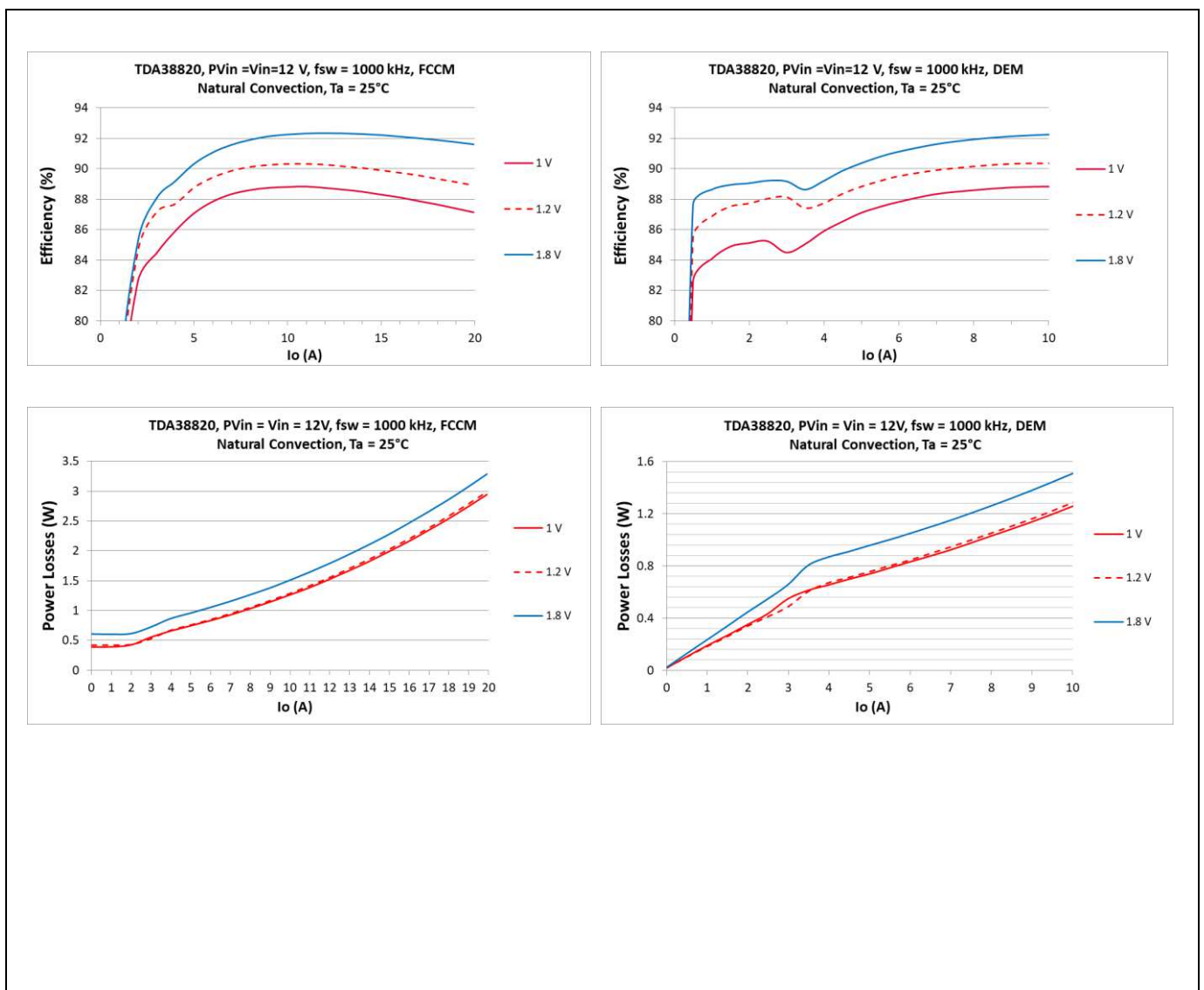

8.4 PVin = Vin = VCC = 5 V, fsw = 600 kHz

PVin = Vin = VCC = 5.0 V, Io = 0 A – 20 A, fsw = 600 kHz, Room Temperature, No Air Flow. Note that the efficiency and power loss curves include the losses of TDA38820, the inductor losses, the losses of the input and output capacitors and and PCB trace losses. The table below shows the inductors used for each of the output voltages in the efficiency measurement.

Table 4 Inductors for PVin = Vin = VCC = 5 V, fsw = 600 kHz

Vout (V)	Lout (nH)	P/N	DCR (mΩ)	Size (mm)
1.0	150	AH3740A-150K (ITG)	0.145	6.4x9.5x10
1.2	215	HCB1075N-211 (Delta)	0.29	10.4 x 8 x 7.5
1.8	215	HCB1075N-211 (Delta)	0.29	10.4 x 8 x 7.5
3.3	215	HCB1075N-211 (Delta)	0.29	10.4 x 8 x 7.5

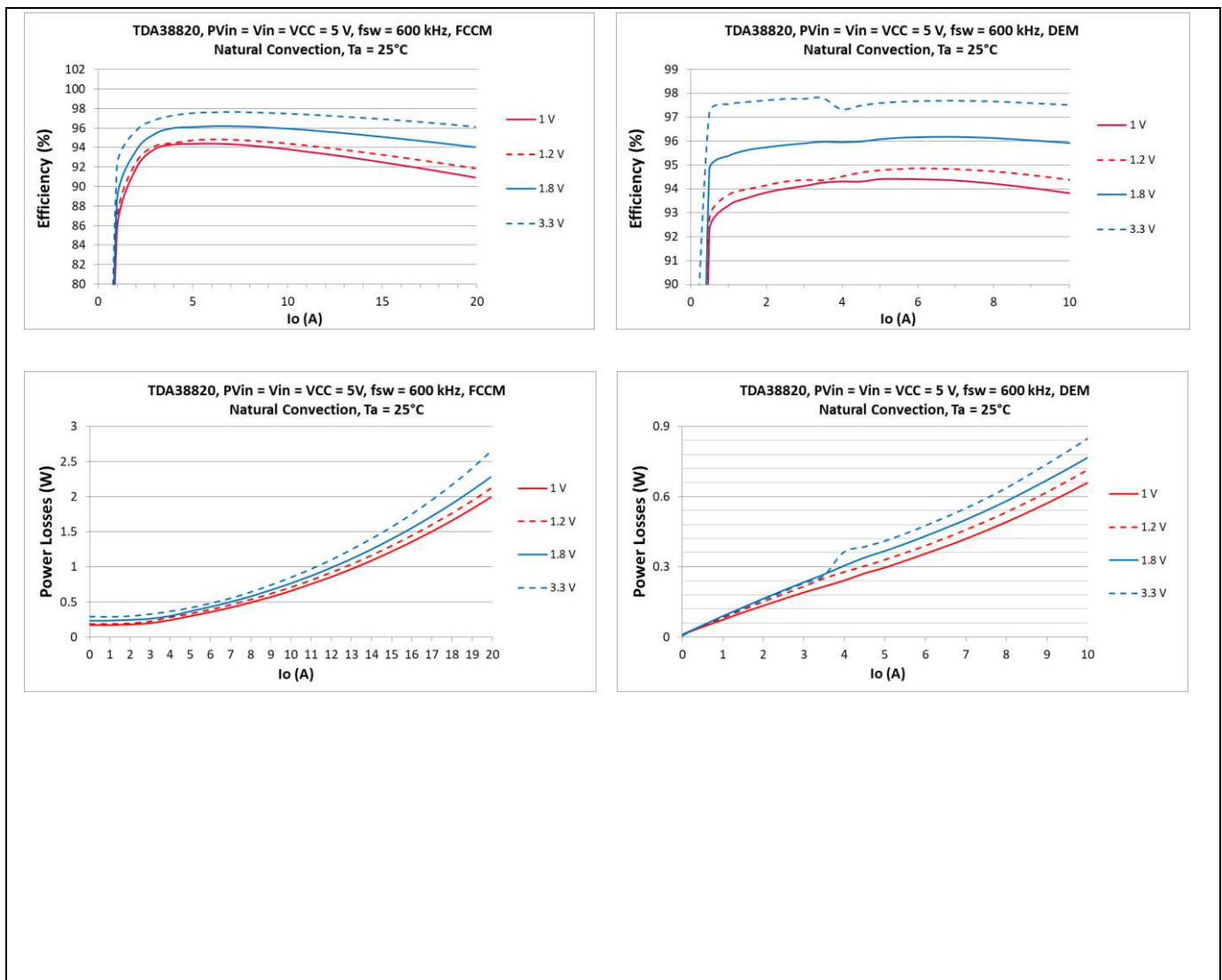

9 Typical operating characteristics (-40 °C ≤ T_j ≤ +125 °C)

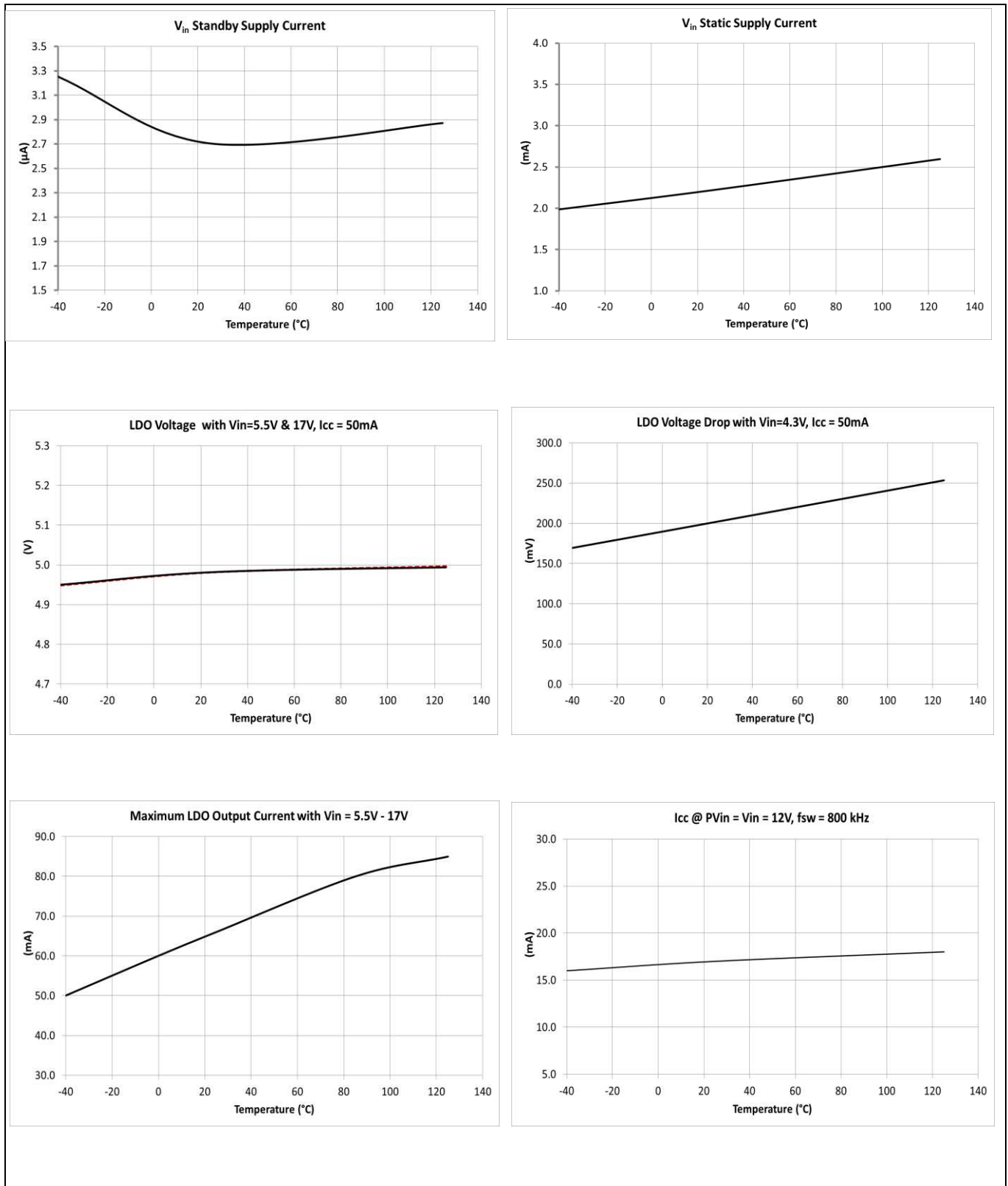

Figure 4 Typical operating characteristics (set 1 of 3)

TDA38820 OptiMOS™ IPOL
20 A single-voltage synchronous Buck regulator
Typical operating characteristics (-40 C ≤ Tj ≤ +125 C)

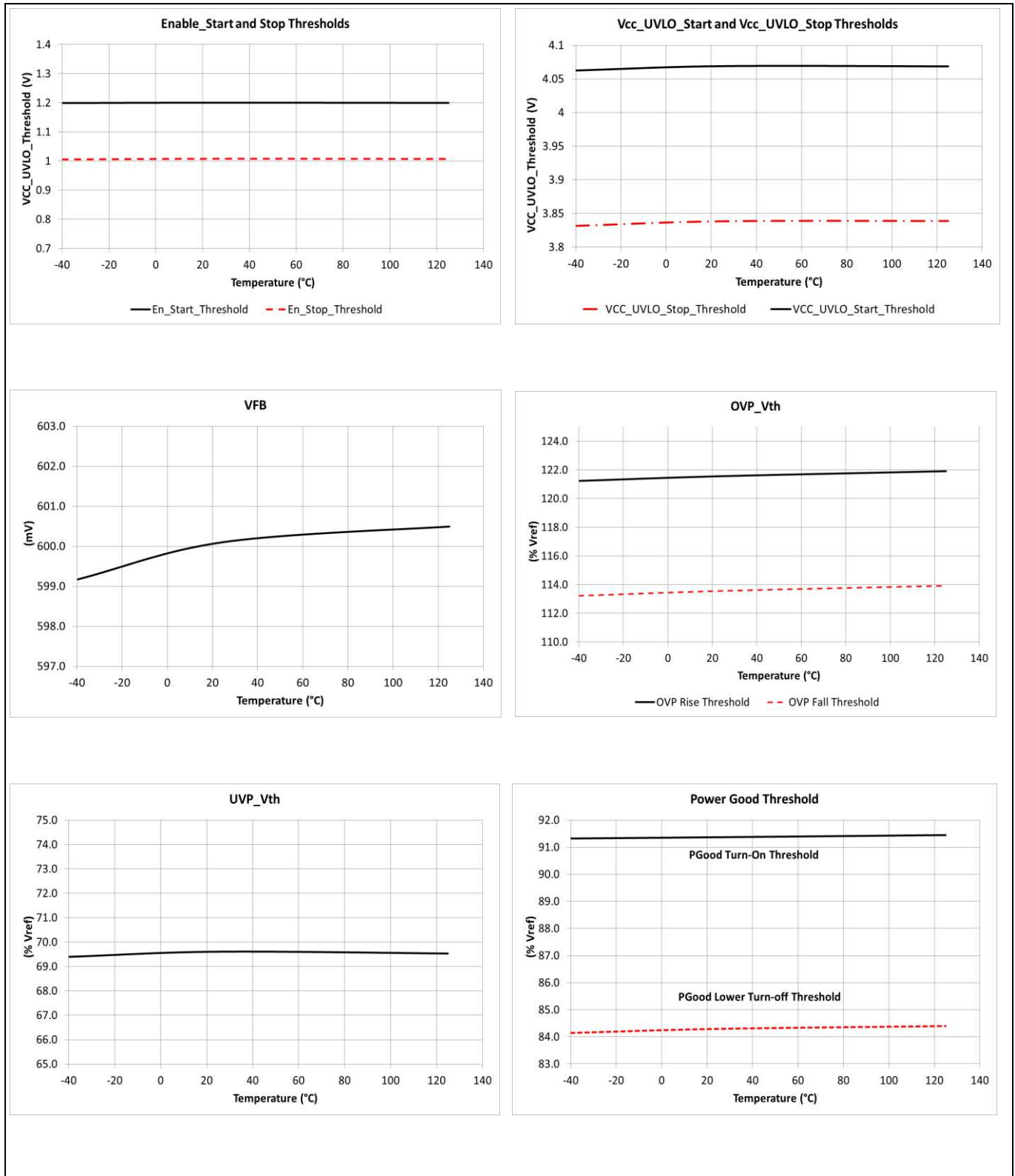

Figure 5 Typical operating characteristics (set 2 of 3)

TDA38820 OptiMOS™ IPOL

20 A single-voltage synchronous Buck regulator

Typical operating characteristics (-40 C ≤ Tj ≤ +125 C)

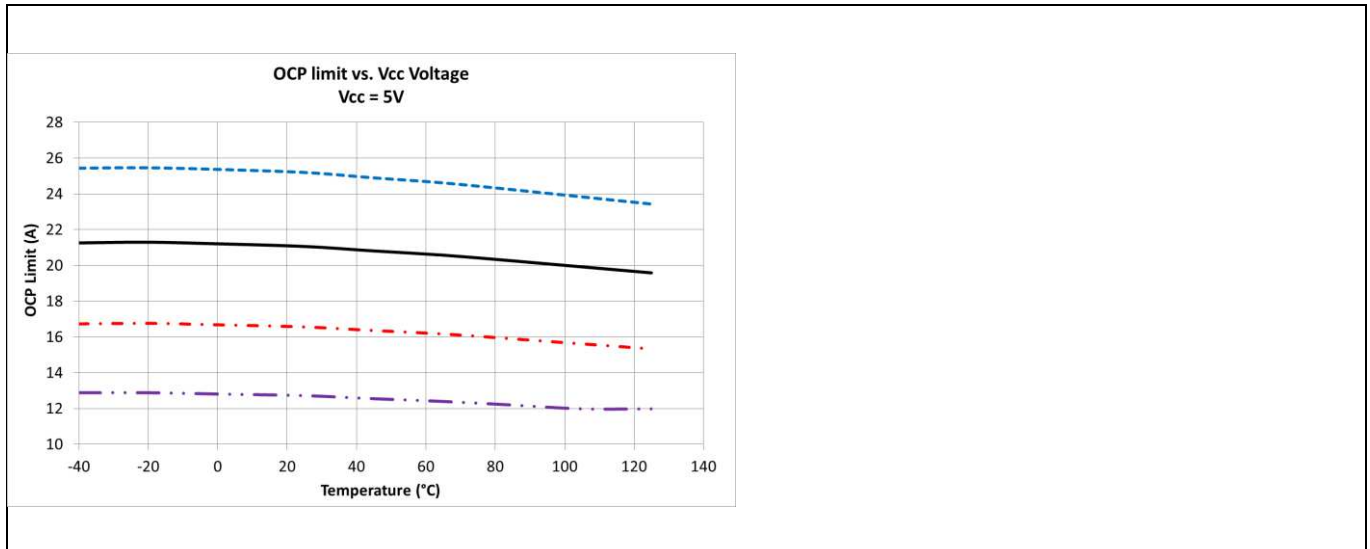

Figure 6 Typical operating characteristics (set 3 of 3)

10 Thermal De-rating curves

Measurement is done on Evaluation board of EVAL_38820. PCB is a 6-layer board with 1.5 ounce Copper for top and bottom layer and 2 z Copper for the inner layers, FR4 material, size 3.0”x3.75”.

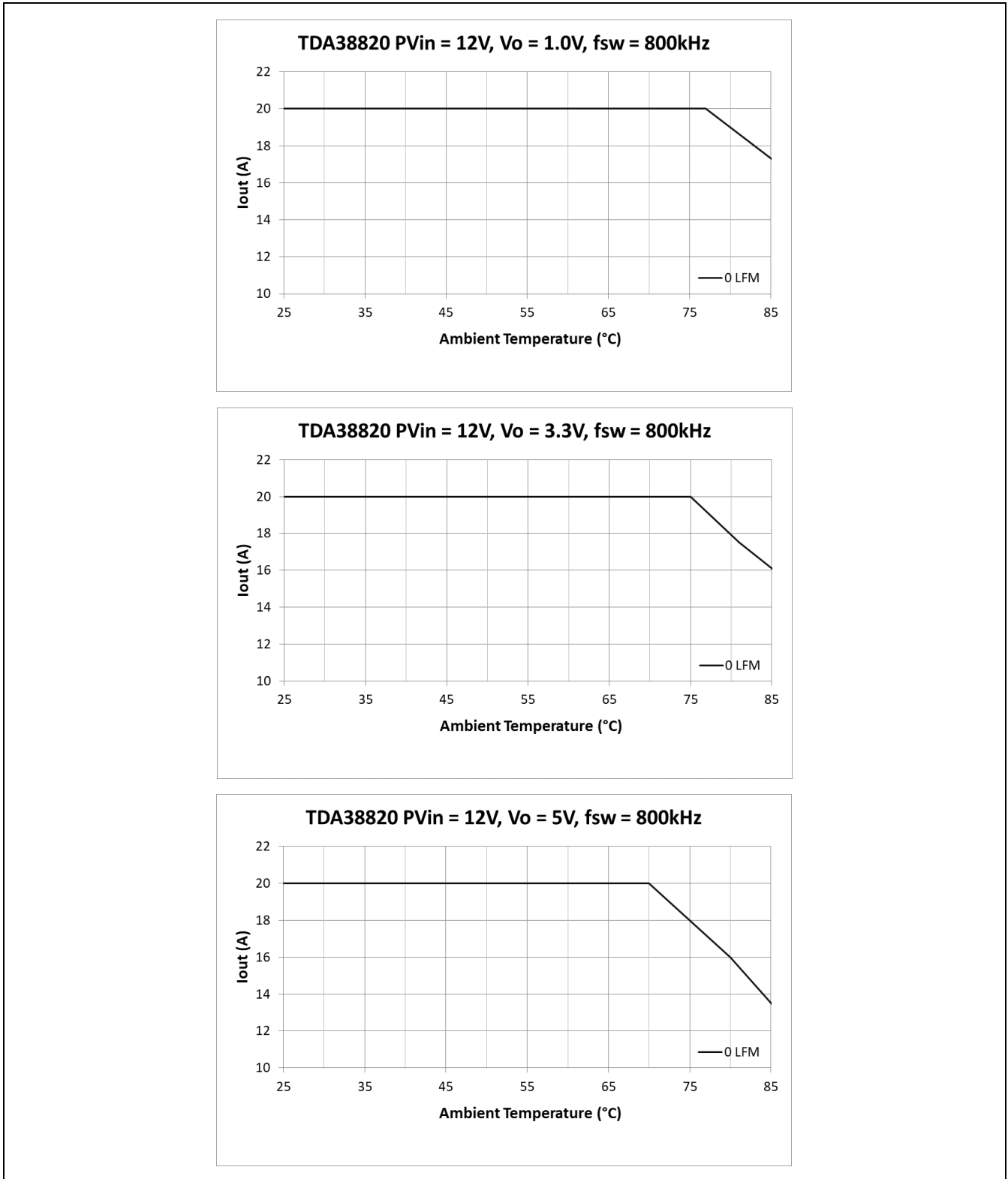

Figure 7 Thermal de-rating curves, PVin = 12 V, Vout=1.0 V/3.3 V/5 V, fsw = 800 kHz, VCC = Internal LDO

11 R_{DS(on)} of MOSFET Over Temperature

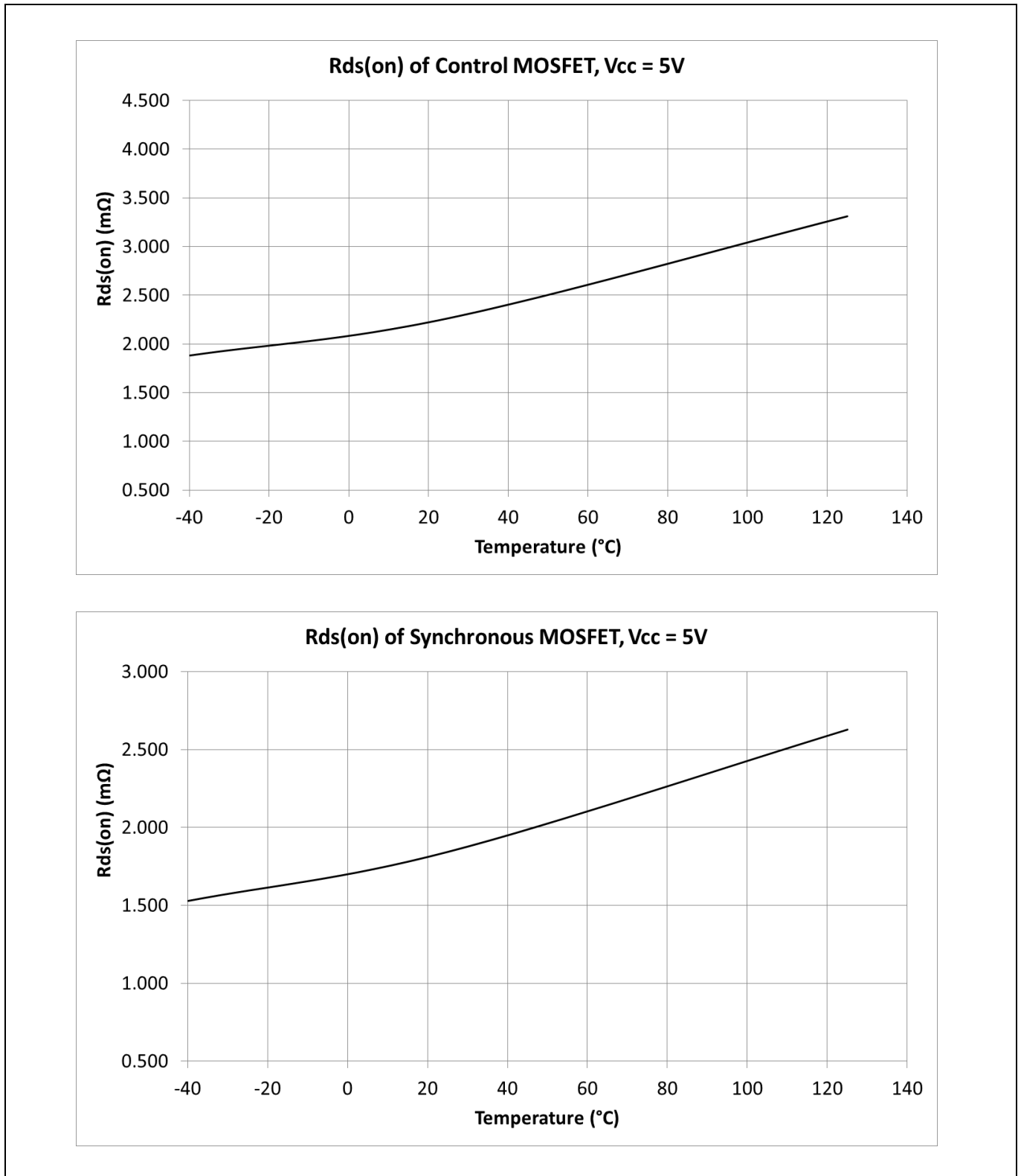

Figure 8 R_{DS(on)} of MOSFETs over Junction Temperature

12 Theory of operation

12.1 Fast Constant On-Time Control

The TDA38820 features a proprietary Fast Constant On-Time (COT) Control, which can provide fast load transient response, good output regulation and minimize the design effort. Fast COT control compares the output voltage, V_o , to a floor voltage combined with an internal ramp signal. When V_{out} drops below that signal, a PWM signal is initiated to turn on the high-side FET for a fixed on-time. The floor voltage is generated from an internal compensated error amplifier, which compares the V_{out} with a reference voltage. Compared to the traditional COT control, Fast COT control significantly improves the V_{out} regulation.

12.2 Enable

En pin controls the on/off of the TDA38820. An internal Under Voltage Lock-Out (UVLO) circuit monitors the En voltage. When the En voltage is above an internal threshold, the internal LDO starts to ramp up. When the VCC/LDO voltage rises above the VCC_UVLO_Start threshold, the soft-start sequence starts. The En pin can be configured in three ways, as shown in **Figure 9**. With configuration 2, the Enable signal is derived from the PVin voltage by a set of resistive divider, R_{EN1} and R_{EN2} . By selecting different divider ratios, users can program a UVLO threshold voltage for the bus voltage. This is a very desirable feature because it prevents the TDA38820 from operating until PVin is higher than a desired voltage level. For some space constrained designs, the En pin can be directly connected to PVin without using the external resistor dividers, as shown in Configuration 3. The En pin should not be left floating. A pull down resistor in the range of tens of kilohms is recommended. **Figure 10** illustrates the corresponding start-up sequences with three En configurations.

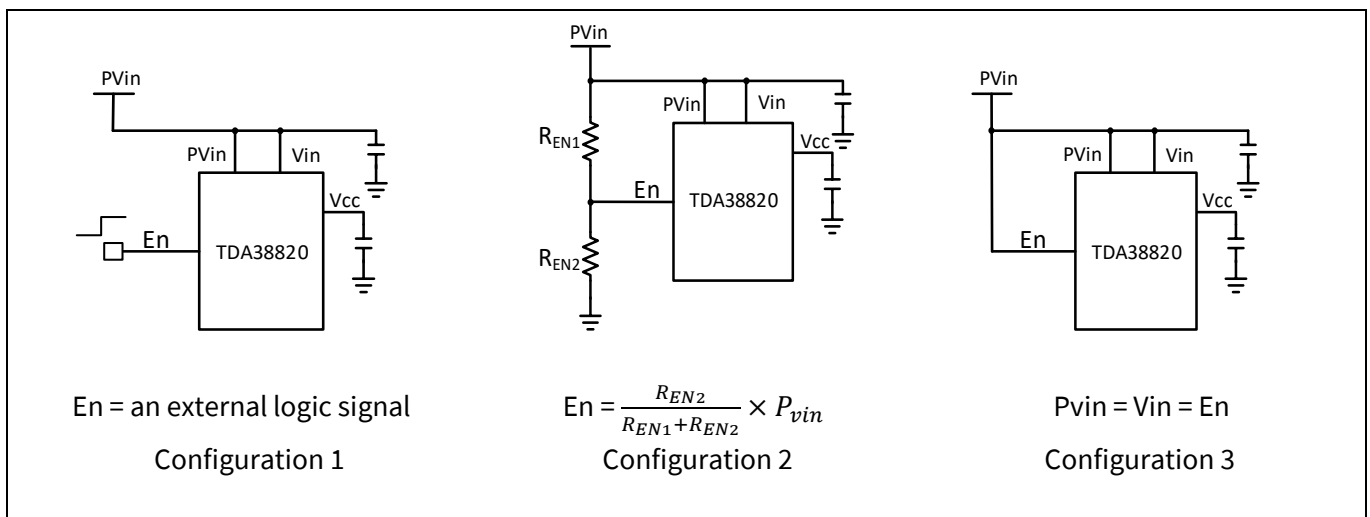

Figure 9 Enable Configurations

Theory of operation

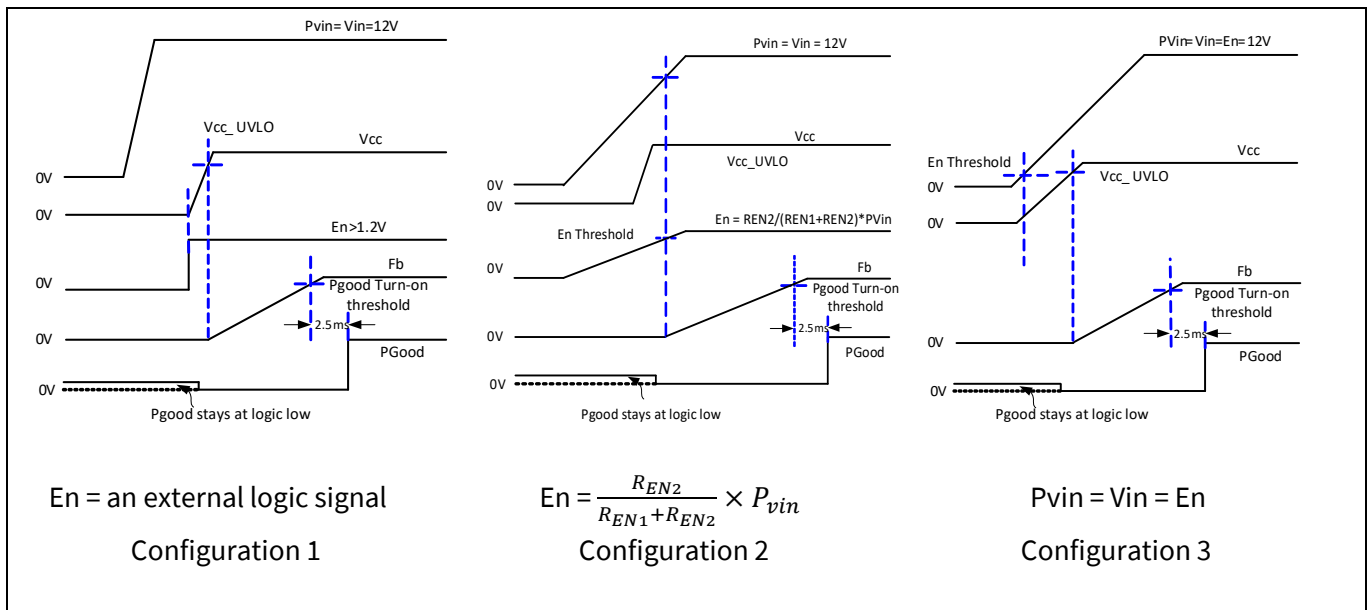

Figure 10 Start-up sequence

12.3 FCCM and DEM Operation

The TDA38820 offers two operation modes: Forced Continuous Conduction (FCCM) and Diode Emulation Mode (DEM). With FCCM, the TDA38820 always operates as a synchronous buck converter with a pseudo constant switching frequency and therefore achieves small output voltage ripples. In DEM, the synchronous FET is turned off when the inductor current is close to zero, which reduces the switching frequency and improves the efficiency at light load. At heavy load, both FCCM and DEM operate in the same way. The operation mode can be selected with TON/MODE pin, as shown in [Table 5](#). It should be noted that the selection of the operation mode cannot be changed on the fly. To load a new TON/MODE configuration, En or VCC voltage needs to be cycled.

12.4 Pseudo Constant Switching Frequency

The TDA38820 offers eight programmable switching frequencies, f_{sw} , from 600 kHz to 2 MHz, by connecting an external resistor from Ton/Mode pin to the ground. Based on the selected f_{sw} , the TDA38820 generates the corresponding on-time of the Control FET for a given PV_{in} and V_o , as shown by the formula below.

$$T_{on} = \frac{V_o}{PV_{in}} \times \frac{1}{f_{sw}}$$

Where f_{sw} is the desired switching frequency. During the operation, the TDA38820 monitors PV_{in} and V_o , and can automatically adjust the on-time to maintain the pre-selected f_{sw} . With the increase of the load, the switching frequency can increase to compensate for the power losses. Therefore, the TDA38820 has a pseudo constant switching frequency.

Table 5 lists the resistors for TON/MODE pin. In this table, E96 resistors with $\pm 1\%$ tolerance are used. If E12 resistor values are preferred, please refer to the Section [12.15](#). To load a new TON/MODE configuration, En or VCC voltage needs to be cycled.

Table 5 Configuration Resistors for TON/MODE Pin

TON/MODE Resistor (kΩ) ±1% Tolerance	Freq (kHz)	Mode
0	600	FCCM
1.5	800	
2.49	1000	
3.48	1200	
4.53	1400	
5.76	1600	
7.32	1800	
8.87	2000	
10.5	600	
12.1	800	
14	1000	
16.2	1200	
18.7	1400	
21.5	1600	
24.9	1800	
28.7	2000	
Ton = Floating	800	FCCM

12.5 Soft-start

The TDA38820 has an internal digital soft-start to control the output voltage rise and to limit the current surge at the start-up. To ensure a correct start-up, the soft-start sequence initiates when the EN and VCC voltages rise above their respective thresholds. The internal soft-start signal linearly rises from 0 V to 0.6 V in a defined time duration. The soft-start time does not change with the output voltage. During the soft-start, the TDA38820 operates in DEM until 1ms after the output voltage ramps above the PGood turn-on threshold. The TDA38820 has four soft-start time options selected by placing a resistor from SS/Latch pin to the ground. **Table 6** lists the resistor values and its corresponding soft-start time. In this table, E96 resistors with ±1% tolerance are used. If E12 resistor values are preferred, please refer to the Section **12.15**. For each soft-start time, there are two resistor options available. Please note that SS/Latch pin is a multi-function pin, which is also used to select different responses for Over Voltage Protection (OVP). Please note that to load a new SS/Latch selection, En or VCC voltage needs to be cycled.

Theory of operation

Table 6 Configuration Resistor for SS/Latch Pin

SS/Latch Resistor (kΩ) ±1% Tolerance	Soft-start Time (ms)	OVP	
0	1	Latch	
4.53			
1.5	2		
5.76			
2.49	4		
7.32			
3.48	8		
8.87			
10.5	1		No Latch
18.7			
12.1	2		
21.5			
14	4		
24.9			
16.2	8		
28.7			
SS/Latch = Floating	4	Latch	

12.6 Pre-bias Start-up

The TDA38820 is able to start up into a pre-charged output without causing oscillations and disturbances of the output voltage. When TDA38820 starts up with a pre-biased output voltage, both control FET and Synch FET are kept off till the internal soft-start signal exceeds the FB voltage.

12.7 Internal Low - Dropout (LDO) Regulator

The TDA38820 has an integrated low-dropout LDO regulator, providing the bias voltage for the internal circuitry. To minimize the standby current, the internal LDO is disabled when the En voltage is pulled low. VIN pin is the input of the LDO. When using the internal LDO for a single rail operation, VIN pin should be connected to PVIN pin. To save the power losses on the LDO, an external bias voltage can be used by connecting VIN pin to the VCC/LDO pin. **Figure 11** illustrates the configuration of VCC/LDO, and VIN pin.

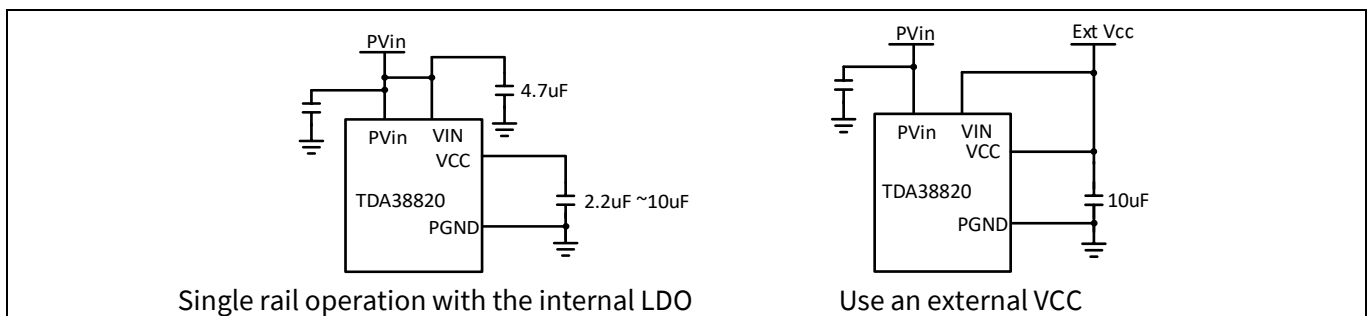

Figure 11 Configuration of Using the internal LDO or an external VCC.

Theory of operation

Section 7.1 specified the recommended operating voltage range of V_{in} and VCC under different configurations. Following design guidelines are recommended when configuring the VCC/LDO.

- Place a bypass capacitor to minimize the disturbance on the VCC pin. For a single rail operation using the internal LDO, a 4.7 μF low ESR ceramic capacitor must be used between VIN pin and PGND and a 2.2 μF ~10 μF low ESR ceramic capacitor is required to be placed close to the VCC/LDO with reference to PGND. 10 μF MLCC is recommended for VCC bypass capacitor when VIN is below 5.5 V. When using an external VCC bias voltage, a 10 μF ceramic capacitor can be shared with VIN, and VCC/LDO pin.
- For applications using the internal LDO with $4.3\text{ V} \leq V_{in} \leq 5.4\text{ V}$, the LDO can be in the dropout mode. It is important to ensure that the LDO voltage does not fall below the VCC UVLO threshold voltage. At $V_{in} = 4.3\text{ V}$, I_{CC} must not exceed 50 mA under all operating conditions such as during a step-up load transient, in which the control loop may require the increase of f_{sw} . OCP limits can be reduced due to the lower VCC voltage.

12.8 Over Current Protection (OCP)

The TDA38820 offers cycle-by-cycle OCP response with four selectable current limits, which is set by the resistance between ILIM pin and GND. The selected OCP limit bank is loaded to the IC during the power up and cannot be changed on the fly. To change the OCP limit, users must cycle EN signal or VCC voltage. Cycle-by-cycle OCP response allows the TDA38820 to fulfill a brief high current demand, such as a high inrush current during the start-up. The detailed operation is explained as follows.

The OCP is activated when EN voltage is above its threshold. The OCP circuitry monitors the current of the Synchronous MOSFET through its $R_{ds(on)}$. When a new PWM pulse is requested by the control loop, if the current of Synchronous MOSFET exceeds the selected OCP limit, the TDA38820 skips the PWM pulse and extends the on-time of Synchronous MOSFET till the current drops below the OCP limit. The OCP operation is also illustrated in **Figure 12**. As can be seen, during OCP events, the valley of the inductor current is regulated around the OCP limit. But during the first switching cycle when the OCP is tripped, the valley of the inductor current can drop below the OCP limit due to skipped pulses. It should be noted that OCP events do not pull the PGood signal low unless the V_o drops below the PGood turn-off threshold. If the OCP event persists, the output voltage can eventually drop below the Under Voltage Protection (UVP) threshold and trigger UVP. Then the TDA38820 enters a hiccup mode.

The OCP limits specified in the Section 7.2 refer to the valley of the inductor current when OCP is tripped. Therefore, the corresponding output DC current can be calculated as follows:

$$I_{out_OCP} = I_{OC} + \frac{\Delta i_L}{2}$$

Where I_{out_OCP} = Output DC current when OCP is tripped. I_{OC} = OCP limit specified in the Section 7.2, which is the valley of inductor current. Δi_L = Peak-peak inductor ripple current. To achieve the desired I_{out_OCP} , Δi_L is recommended to meet the following criterion

$$\Delta i_L \geq 2 \times (I_{out_OCP} - I_{OC_min})$$

Where I_{OC_min} = the minimum spec of OCP limit. For example, for a 20A rail, to achieve $I_{out_OCP} \geq 24\text{A}$, it is recommended to select $\Delta i_L \geq 6.6\text{ A}$.

To avoid the inductor saturation during OCP events, the following criterion is recommended for the inductor saturation current rating.

$$I_{sat} \geq I_{OC_max} + \Delta i_L$$

Where I_{sat} is the inductor saturation current and I_{OC_max} is the maximum spec of the OCP limit.

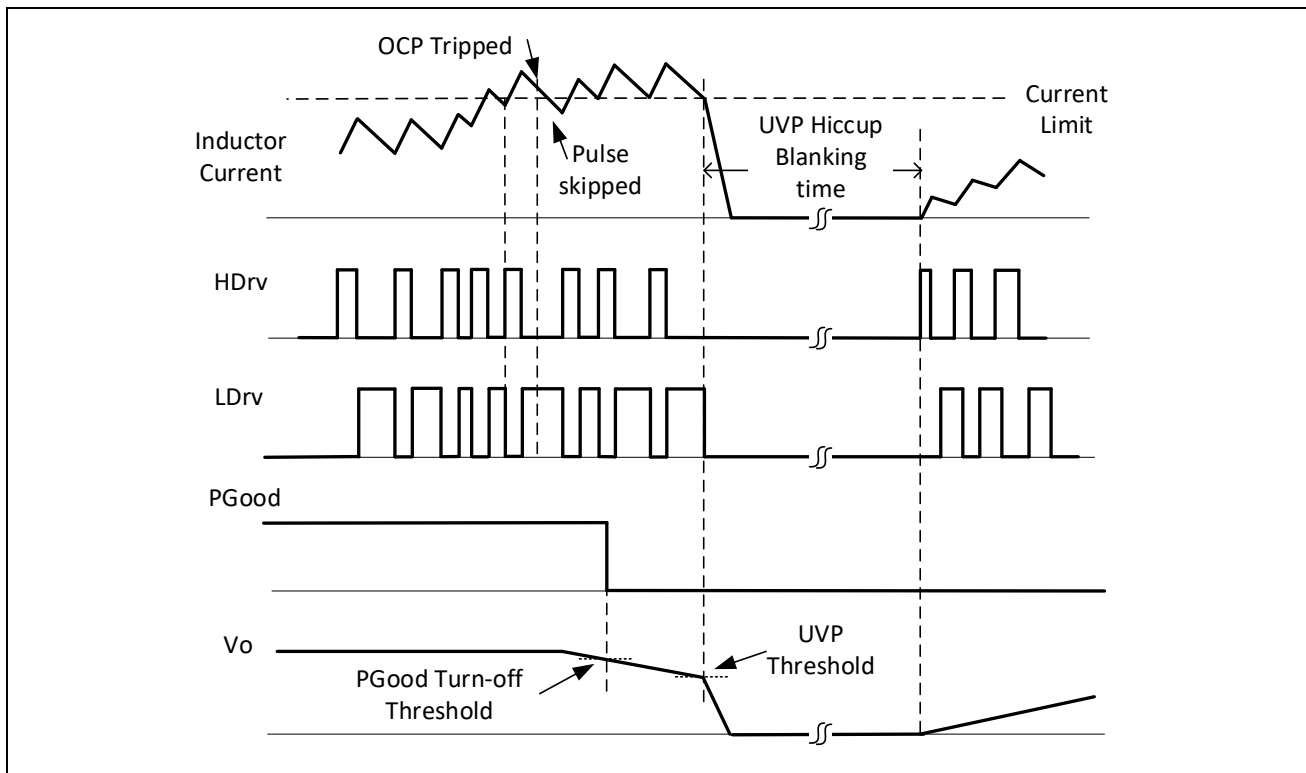

Figure 12 Cycle-by-cycle OCP response

12.9 Under Voltage Protection (UVP)

Under Voltage Protection (UVP) provides additional protection during OCP fault or other faults. UVP is activated when the soft-start voltage rises above 100 mV. UVP circuitry monitors the FB voltage. When it is below the UVP threshold for 2 μ s (typical), an under voltage trip signal asserts and both Control MOSFET and Synchronous MOSFET are turned off. The TDA38820 enters a hiccup mode with a blanking time of 20 ms, during which Control MOSFET and Synchronous MOSFET remain off. After the completion of blanking time, the TDA38820 attempts to recover to the nominal output voltage with a soft-start, as shown in [Figure 12](#). The TDA38820 will repeat hiccup mode and attempt to recover until UVP condition is removed.

12.10 Over Voltage Protection (OVP)

Over Voltage Protection (OVP) is achieved by comparing the FB voltage to an OVP threshold voltage. When the FB voltage exceeds the OVP threshold, an over voltage trip signal asserts after 8 μ s (typical) delay. Control MOSFET is latched off immediately and PGood flags low. Synchronous MOSFET remains on to discharge the output capacitor. When FB voltage drops below around 115% of the reference voltage, Synchronous MOSFET turns off to prevent the complete depletion of the output capacitors. [Figure 13](#) illustrates the OVP operation. The OVP comparator becomes active when the EN signal is above the start threshold.

With SS/Latch pin, two OVP responses can be selected: Latch or No Latch, as shown in [Table 6](#). With a latched OVP response, Control FET remains latched off until either VCC voltage or EN signal is cycled. With an unlatched OVP response, the TDA38820 enters a hiccup mode. Control FET remains off for a blanking time of 20ms. After hiccup blanking time expires, the TDA38820 will try to restart with a soft-start. The TDA38820 can stay in the hiccup mode infinitely if over voltage fault persists.

Theory of operation

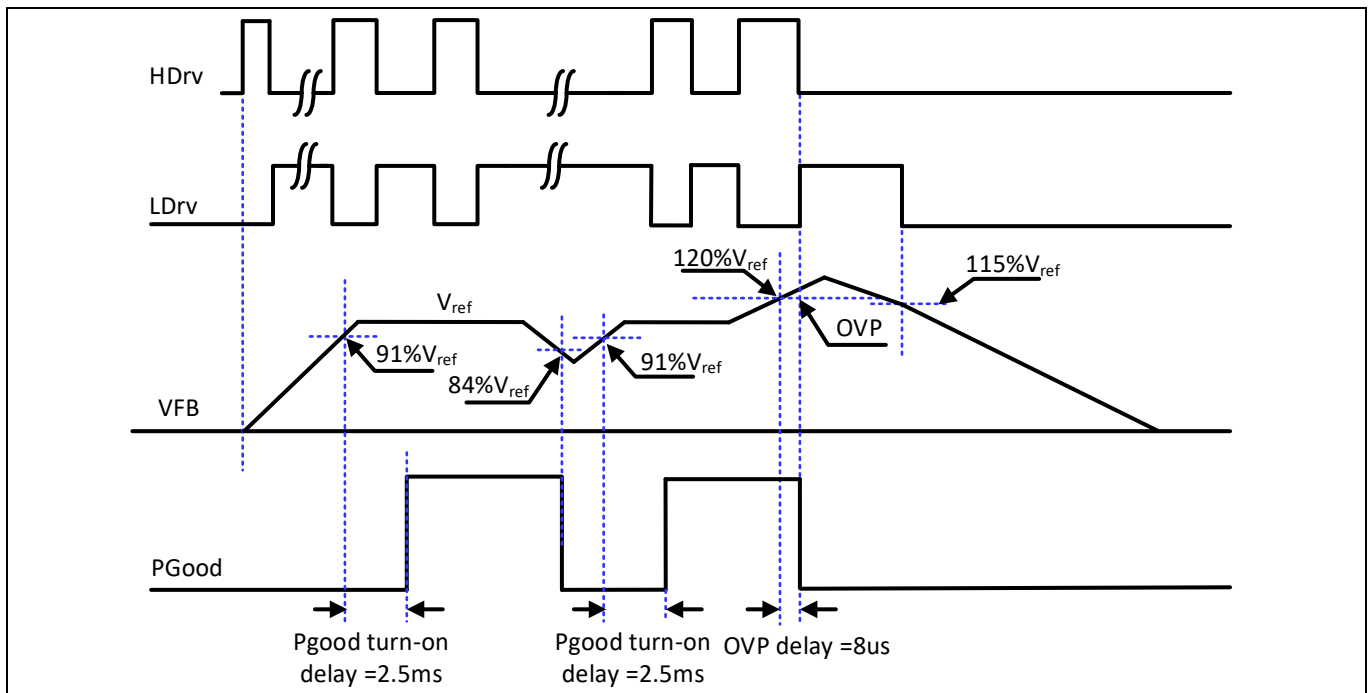

Figure 13 Over voltage protection response and PGood behavior.

12.11 Over Temperature Protection (OTP)

Temperature of the controller is monitored internally. When the temperature exceeds the over temperature threshold, OTP circuitry turns off both Control and Synchronous MOSFETs and resets the internal soft start. Automatic restart is initiated when the sensed temperature drops back into the operating range. The thermal shutdown threshold has a hysteresis of 20 °C.

12.12 Power Good (PGood) Output

The PGood pin is the open drain of an internal NFET, and needs to be externally pulled high through a pull-up resistor. PGood signal is high when three criteria are satisfied.

1. EN signal and VCC voltage are above their respective thresholds.
2. No over voltage and over temperature faults occur.
3. V_o is within the regulation.

In order to detect if V_o is in regulation, PGood comparator continuously monitors the FB voltage. When FB voltage ramps up above the upper threshold, PGood signal is pulled high after 2.5 ms. When FB voltage drops below the lower threshold, PGood signal is pulled low immediately. **Figure 13** illustrates the PGood response.

During the start-up with a pre-biased voltage, PGood signal is held low before the first PWM is generated and is then pulled high with 2.5 ms delay after FB voltage rises above the PGood threshold. TDA38820 also integrates an additional PFET in parallel to the PGood NFET, as shown in **Figure 2**. This PFET allows PGood signal to stay at logic low when the VCC voltage is not present, and PGood pin is pulled up by an external bias voltage. Please refer to **Figure 10**. Since PGood PFET has relatively higher on resistance, a 50 kΩ pull-up resistor is needed for a PGood bias voltage of 3.3 V to maintain the PGood signal at logic low when PGood PFET is on.

12.13 Minimum On - Time and Minimum Off - Time

The minimum on-time refers to the shortest time for Control MOSFET to be reliably turned on. The minimum off-time refers to the minimum time duration in which Synchronous FET stays on before a new PWM pulse is generated. The minimum off-time is needed for TDA38820 to charge the bootstrap capacitor, and to sense the current of the Synchronous MOSFET for OCP.

For applications requiring a small duty cycle, it is important that the selected switching frequency results in an on-time larger than the maximum spec of the minimum on-time in the Section 7.2. Otherwise the resulting switching frequency may be lower than the desired target. Following formula could be used to check for the minimum on-time requirement.

$$\frac{V_0}{k f_{sw} \times PV_{in}} > \max \text{ spec of } T_{on(\min)}$$

Where f_{sw} is the desired switching frequency. k is the variation of the switching frequency. As a rule of thumb, select $k = 1.25$ to ensure the design margin.

For applications requiring a high duty cycle, it is important to make sure a proper switching frequency is selected so that the resulting off-time is longer than the maximum spec of the minimum off-time in the Section 7.2, which can be calculated as shown below.

$$\frac{PV_{in} - V_0}{f_{sw_max} \times PV_{in}} > \max \text{ spec of } T_{off(\min)}$$

Where f_{sw_max} is the maximum switching frequency. In a steady state operation, $f_{sw_max} = k \times f_{sw}$. f_{sw} is the desired switching frequency. k is the variation of the switching frequency. As a rule of thumb, select $k = 1.25$ to ensure the design margin. Please note that during a load step, f_{sw} will increase due to the intrinsic COT operation. Therefore extra design margin needs to be considered to cover the worst case scenario. Also note that OCP limit may be degraded when off-time is close to $T_{off(\min)}$.

The resulting maximum duty cycle is therefore determined by the selected on-time and minimum off-time.

$$D_{max} = \frac{T_{on}}{T_{on} + T_{off(\min)}}$$

12.14 Selection of Feedforward Capacitor and Feedback Resistors

Output voltage can be programmed with an external voltage divider. The FB voltage is compared to an internal reference voltage of 0.6 V. The divider ratio is set to provide 0.6 V at the FB pin when the output is at its desired value. The calculation of the feedback resistor divider is shown below.

$$V_0 = V_{ref} \times \left(1 + \frac{R_{FB1}}{R_{FB2}}\right)$$

Where R_{FB1} and R_{FB2} are the top and bottom feedback resistors.

A small MLCC capacitor, C_{ff} , is preferred in parallel with the top feedback resistor, R_{FB1} , to provide extra phase boost and to improve the transient load response, as shown in Figure 14. Following formula can be used to help select C_{ff} and R_{FB1} . The value of C_{ff} is recommended to be 100 pF or higher to minimize the impact of circuit parasitic capacitance. Where L_o and C_o are the output LC filter of the buck regulator. Table 7 lists the suggested m for some common outputs. C_{ff} and R_{FB1} may be further optimized based on the transient load tests.

$$R_{FB1} C_{ff} = \frac{\sqrt{L_o C_o}}{m \times 4.9}$$

Theory of operation

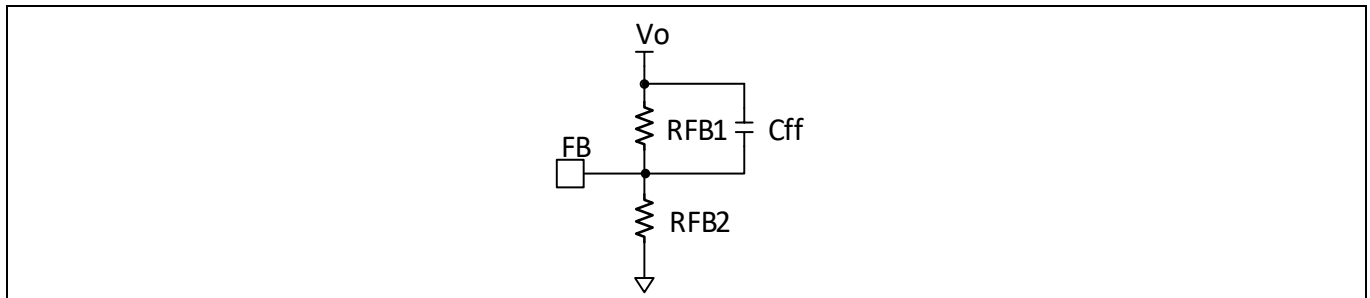

Figure 14 Configuration of feedforward capacitor, Cff.

Table 7 Selection of m

Vo	m
$3\text{ V} \leq V_o \leq 6\text{ V}$	0.3
$1.2\text{ V} < V_o < 3\text{ V}$	0.5
$V_o \leq 1.2\text{ V}$	0.7

12.15 Resistors for Configuration Pins

To properly configure SS/LATCH pin, MODE/TON pin and ILIM pin, E96 resistors with $\pm 1\%$ tolerance must be used per Table 5, Table 6 and Section 7.2. If E12 resistor values are preferred, the E96 resistors can be replaced with two or three E12 resistors in series, as shown in Table 8. Note that the tolerance of E12 resistors must be $\pm 0.1\%$.

Table 8 Replacement of E96 configuration resistors with E12 resistors in series

E96 $\pm 1\%$	E12 $\pm 0.1\%$ ($R = R_{S1} + R_{S2}$ or $R_{S1} + R_{S2} + R_{S3}$)		
	R_{S1} (k Ω)	R_{S2} (k Ω)	R_{S3} (k Ω)
R (k Ω)			
4.53	2.7	1.8	N/A
1.50	1.5	0	N/A
5.76	5.6	0.15	N/A
2.49	1.8	0.68	N/A
7.32	6.8	0.56	N/A
3.45	3.3	0.15	N/A
8.87	8.2	0.68	N/A
10.5	10	0.47	N/A
12.1	12	0.1	N/A
21.5	18	3.3	N/A
14	10	3.9	N/A
24.9	22	2.7	N/A
16.2	15	1.2	N/A
28.7	27	1.8	N/A
21.5	18	3.3	0.18
24.9	22	2.7	0.18

Design example

13 Design example

In this section, an example is used to explain how to design a buck regulator with the TDA38820. The application circuit is shown in Figure 15. The design specifications are given below.

- $PV_{in} = 12\text{ V} (\pm 10\%)$
- $V_o = 1.0\text{ V}$
- $I_o = 20\text{ A}$
- $f_{sw} = 600\text{ kHz}$
- V_o ripple voltage = $\pm 1\%$ of V_o
- Load transient response = $\pm 3\%$ of V_o with a step load current = 6 A and slew rate = 30 A/ μ s

13.1 Enabling the TDA38820

The TDA38820 has a precise Enable threshold voltage, which can be used to implement a UVLO of the input bus voltage by connecting the EN pin to PV_{in} with a resistor divider, as shown in Configuration 2 of Figure 9. The Enable feedback resistor, R_{EN1} and R_{EN2} , can be calculated as follows.

$$PV_{in(\min)} \times \frac{R_{EN2}}{R_{EN1} + R_{EN2}} \geq V_{EN(\max)}$$

$$R_{EN2} \geq R_{EN1} \times \frac{V_{EN(\max)}}{PV_{in(\min)} - V_{EN(\max)}}$$

Where $V_{EN(\max)}$ is the maximum spec of the En-start-threshold as defined in Section 7.2. For $PV_{in(\min)} = 10.8\text{ V}$, select $R_{EN1} = 49.9\text{ k}\Omega$ and $R_{EN2} = 7.5\text{ k}\Omega$.

13.2 Programming the Switching Frequency and Operation Mode

The TDA38820 has very good efficiency performance and is suitable for high switching frequency operation. In this case, 600 kHz is selected to achieve a good compromise between the efficiency, passive component size and dynamic response. In addition, FCCM operation is selected to ensure a small output ripple voltage over the entire load range. To select 600 kHz and FCCM operation, the TON/MODE pin can be shorted to GND with one zero resistor, per Table 5.

13.3 Selecting Input Capacitors

Without input capacitors, the pulse current of Control MOSFET is directly from the input supply power. Due to the impedance on the cable, the pulse current can cause disturbance on the input voltage and potential EMI issues. The input capacitors filter the pulse current, resulting in almost constant current from the input supply. The input capacitors should be selected to tolerate the input pulse current, and to reduce the input voltage ripple. The RMS value of the input ripple current can be expressed by:

$$I_{RMS} = I_o \times \sqrt{D \times (1 - D)}$$

$$D = \frac{V_o}{PV_{in}}$$

Design example

Where I_{RMS} is the RMS value of the input capacitor current. I_o is the output current and D is the Duty Cycle. For $I_o = 20A$ and $D_{(max)} = 0.09$, the resulting RMS current flowing into the input capacitor is $I_{rms} = 5.7 A$.

To meet the requirement of the input ripple voltage, the minimum input capacitance can be calculated as follows.

$$C_{in(min)} > \frac{I_o \times (1 - D) \times D}{f_{sw} \times (\Delta PV_{in} - ESR \times I_o \times (1 - D))}$$

Where ΔPV_{in} is the maximum allowable peak-to-peak input ripple voltage, and ESR is the equivalent series resistor of the input capacitors. Ceramic capacitors are recommended due to low ESR, ESL and high RMS current capability. For $I_o = 20 A$, $f_{sw} = 600 \text{ kHz}$, $ESR = 3 \text{ m}\Omega$, and $\Delta PV_{in} = 240 \text{ mV}$, $C_{in(min)} > 15 \mu\text{F}$. To account for the de-rating of ceramic capacitors under a bias voltage, $10 \times 22 \mu\text{F}/0805/25 \text{ V MLCC}$ are used for the input capacitors. In addition, a bulk capacitor is recommended if the input supply is not located close to the voltage regulator.

13.4 Inductor Selection

The inductor is selected based on output power, operating frequency and efficiency requirements. A low inductor value results in a large ripple current, lower efficiency and high output noise, but helps with size reduction and transient load response. Generally, the peak-to-peak ripple current in the inductor (Δi) is selected between 20% and 60% of the output current.

In addition, as discussed in Section 12.8, TDA38820 detects the valley of the inductor current for OCP. Proper inductor ripple should be used to achieve the desired OCP trip point at the output.

The inductor saturation current must be higher than the maximum spec of the OCP limit plus the peak-to-peak inductor ripple current. For some core material, inductor saturation current may decrease as the increase of temperature. So it is important to check the inductor saturation current at the maximum operating temperature.

The inductor value for the desired operating ripple current can be determined using the following relation:

$$\Delta i_{L(min)} \geq 2 \times (I_{out_OCP} - I_{OC_min})$$

$$\Delta i_{L(max)} \leq I_{sat} - I_{OC_max}$$

$$\Delta i_{L(max)} = (PV_{in(max)} - V_o) \times \frac{D_{min}}{L \times F_{sw}}, \quad \Delta i_{L(min)} = (PV_{in(min)} - V_o) \times \frac{D_{max}}{L \times F_{sw}}$$

$$D_{min} = \frac{V_o}{PV_{in(max)}}, \quad D_{max} = \frac{V_o}{PV_{in(min)}}$$

Where: PV_{in} = input voltage; Δi_L = peak-to-peak inductor ripple current; I_{OC} = valley current OCP limit as defined in Section 7.2; I_{sat} = inductor saturation current; and I_{out_OCP} = desired OCP trip point at the output. In this case, select inductor $L = 215 \text{ nH}$ to achieve $\Delta i_{L_max} = 35\%$ of I_{o_max} , and $I_{out_OCP} \geq 121\%$ of I_{o_max} . The I_{sat} should be no less than 36 A.

13.5 Output Capacitor Selection

The output capacitor selection is mainly determined by the output voltage ripple and transient requirements.

To satisfy the V_o ripple requirement, C_o should satisfy the following criterion.

$$C_o > \frac{\Delta i_{Lmax}}{8 \times \Delta V_{or} \times f_{sw}}$$

Where ΔV_{or} is the desired peak-to-peak output ripple voltage. For $\Delta i_{L_max} = 7.16 A$, $\Delta V_{or} = 20 \text{ mV}$, $f_{sw} = 600 \text{ kHz}$, C_o must be larger than $75 \mu\text{F}$. The ESR and ESL of the output capacitors, as well as the parasitic resistance or

Design example

inductance due to PCB layout, can also contribute to the output voltage ripple. It is suggested to use Multi-Layer Ceramic Capacitor (MLCC) for their low ESR, ESL and small size.

To meet the transient response requirements, the output capacitors should also meet the following criterion.

$$C_o > \frac{L \times \Delta I_{o(max)}^2}{2 \times \Delta V_{oL} \times V_o}$$

Where ΔV_{oL} is the allowable V_o deviation during the load transient. $\Delta I_{o(max)}$ is the maximum step load current. Please note that the impact of ESL, ESR, control loop response, transient load slew rate, and PWM latency is not considered in the calculation shown above. Extra capacitance is usually needed to meet the transient requirements. As a rule of thumb, we can triple the C_o that is calculated above as a starting point, and then optimize the design based on the bench measurement. In this case, to meet the transient load requirement (i.e. $\Delta V_{oL} = 30$ mV, $\Delta I_{o(max)} = 6$ A), select $C_o = \sim 767$ μ F. For more accurate estimation of C_o , simulation tool should be used to aid the design.

13.6 Output Voltage Programming

Output voltage can be programmed with an external voltage divider. The FB voltage is compared to an internal reference voltage of 0.6 V. The divider ratio is set to provide 0.6 V at the FB pin when the output is at its desired value. The calculation of the feedback resistor divider is shown below.

$$V_o = V_{ref} \times \left(1 + \frac{R_{FB1}}{R_{FB2}}\right)$$

Where R_{FB1} and R_{FB2} are the top and bottom feedback resistors. Select $R_{FB1} = 7.5$ k Ω and $R_{FB2} = 11.3$ k Ω , to achieve $V_o = 1$ V.

13.7 Feedforward Capacitor

A small MLCC capacitor, C_{ff} , can be placed in parallel with the top feedback resistor, R_{FB1} , to improve the transient response. Based on Section 12.14, C_{ff} can be selected using the following formula.

$$R_{FB1} C_{ff} = \frac{\sqrt{L_o C_o}}{m \times 4.9}$$

With $L_o = 215$ nH, $C_o = 767$ μ F, $m = 0.7$, and $R_{FB1} = 7.5$ k Ω , $C_{ff} = \sim 500$ pF. Then 680 pF is selected for C_{ff} .

13.8 Bootstrap Capacitor

For most applications, a 0.1 μ F ceramic capacitor is recommended for bootstrap capacitor placed between PHASE and BOOT Pin. For applications requiring PV_{in} equal to or above 14 V, a small resistor of 1~2 Ω might be used in series with the BOOT pin to ensure the maximum SW node spike voltage does not exceed 20 V.

13.9 VIN, and VCC/LDO bypass Capacitor

Please see the recommendation in Section 12.7. A 10 μ F MLCC is selected for VCC/LDO bypass capacitor and a 4.7 μ F MLCC is selected for VIN bypass capacitor.

14 Application Information

14.1 Application Diagram

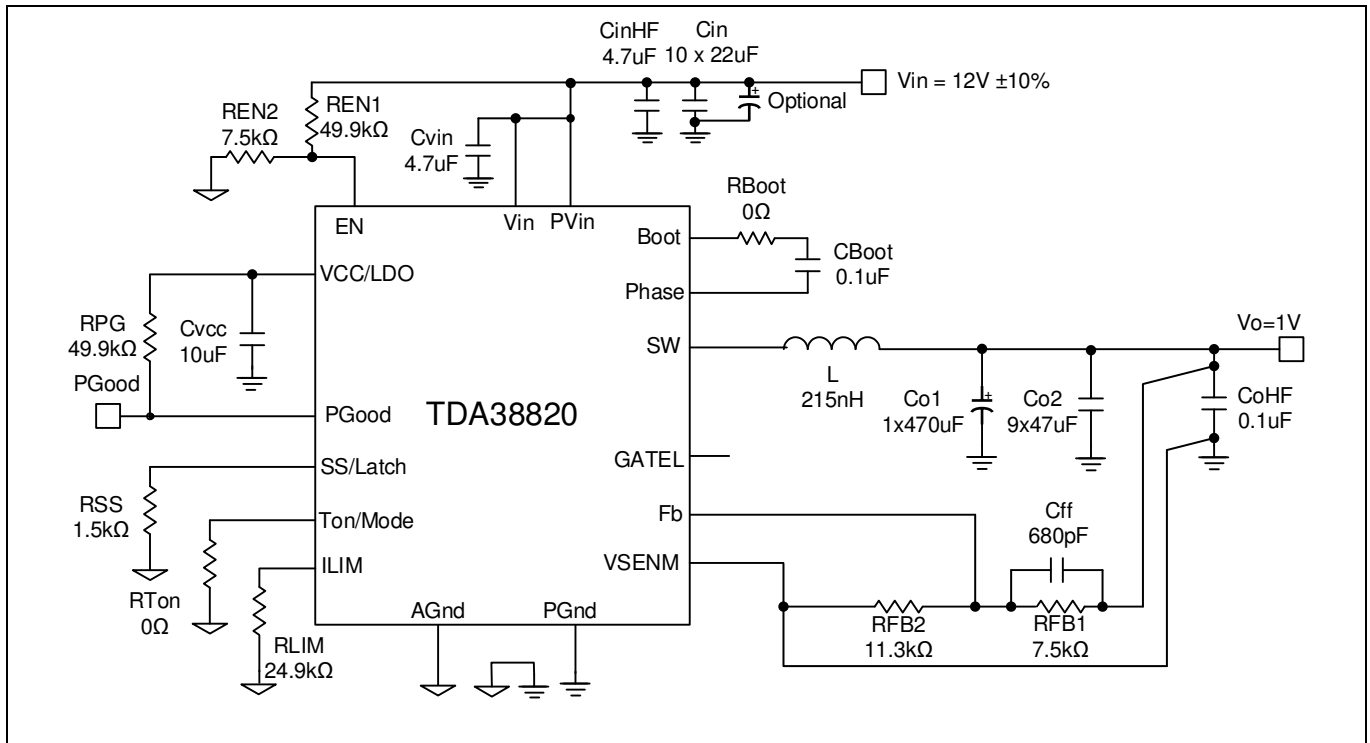

Figure 15 Application diagram of TDA38820. $P_{Vin} = 12\text{ V}$, $V_o = 1\text{ V}$, $I_o = 20\text{ A}$, $f_{sw} = 600\text{ kHz}$.

14.2 Typical Operating Waveforms

$P_{Vin} = V_{in} = 12.0\text{ V}$, $V_o = 1\text{ V}$, $I_o = 0 - 20\text{ A}$, $f_{sw} = 600\text{ kHz}$, Room Temperature, no airflow

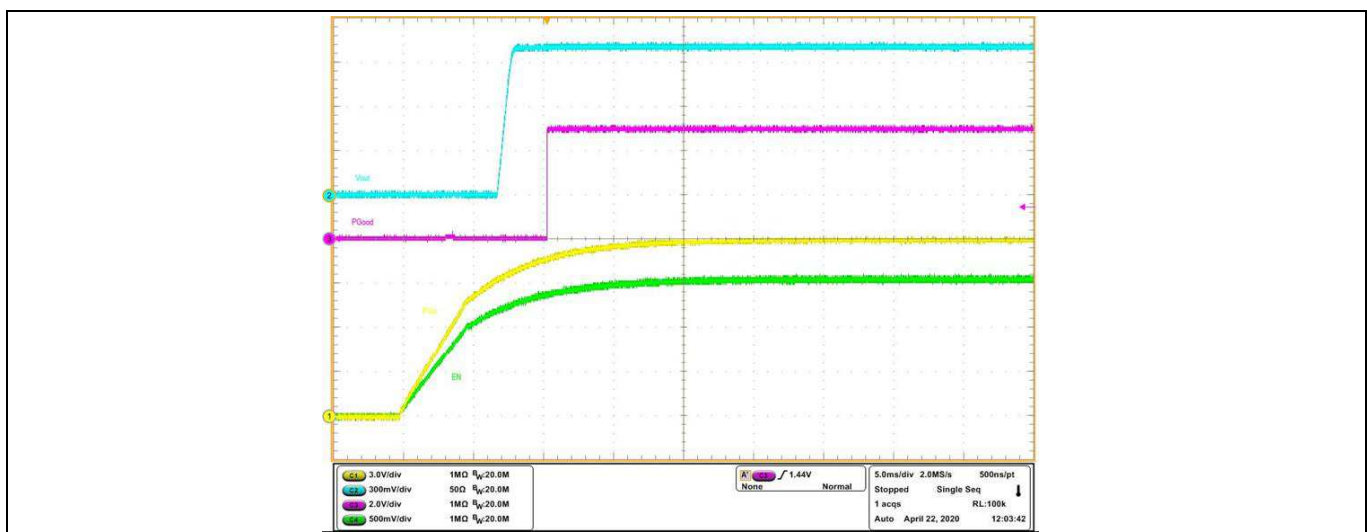

Figure 16 Start up at 20 A Load, (Ch1: P_{Vin} , Ch2: V_{out} , Ch3: P_{Good} , Ch4: Enable)

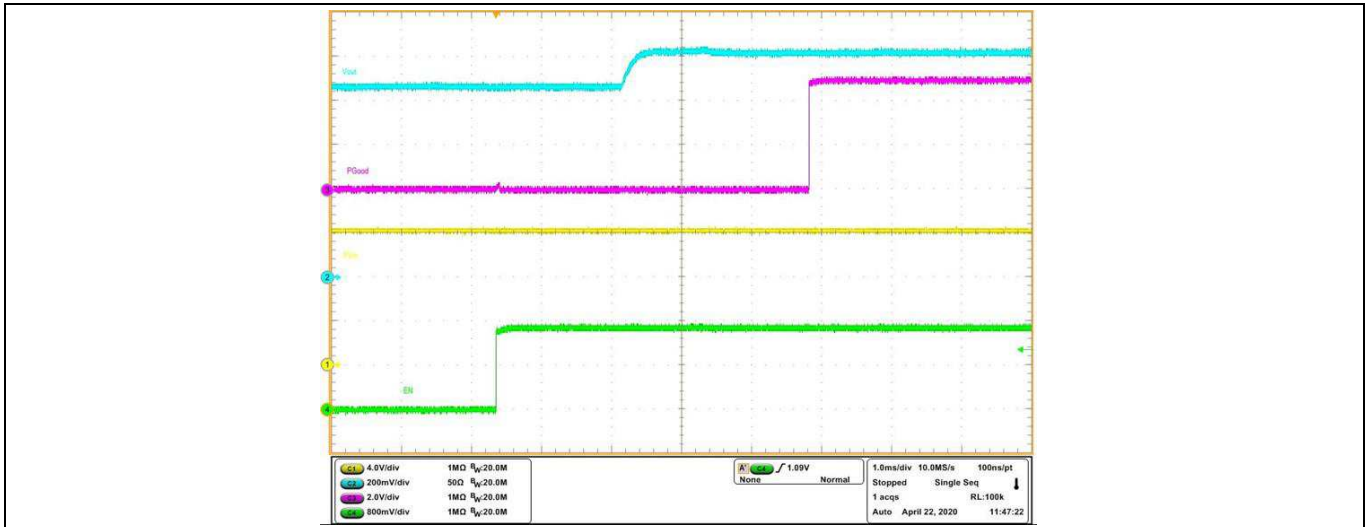

Figure 17 Pre-bias Start up at 0 A Load, (Ch1: PV_{in}, Ch2: V_{out}, Ch3:P_{Good} ,Ch4:Enable)

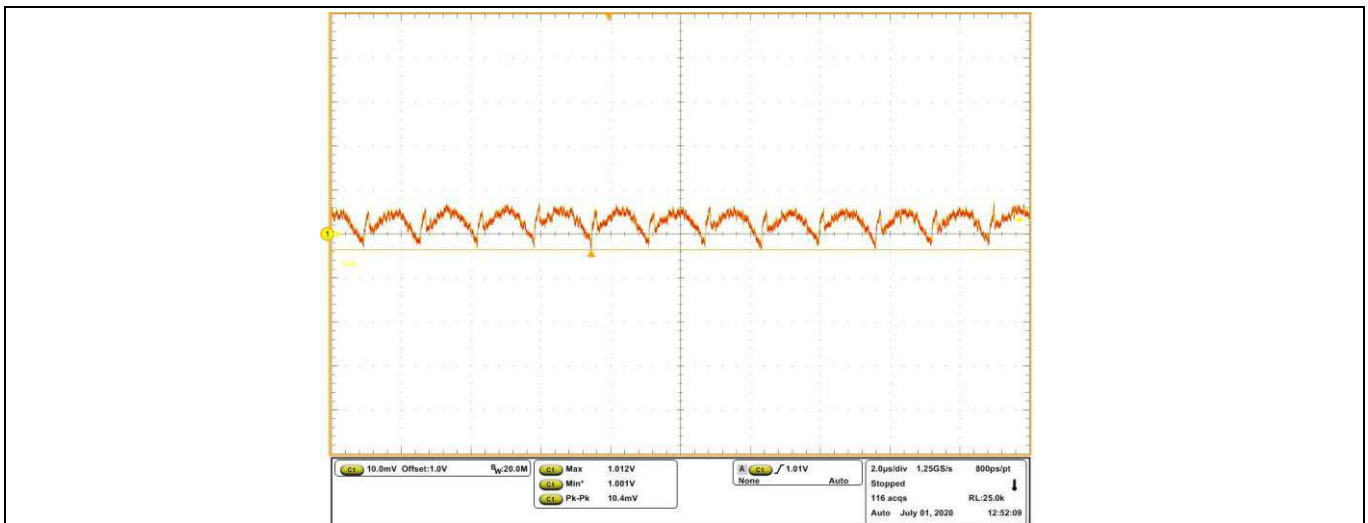

Figure 18 Vout ripple at 20 A Load, fsw = 600 kHz, (Ch1: V_o)

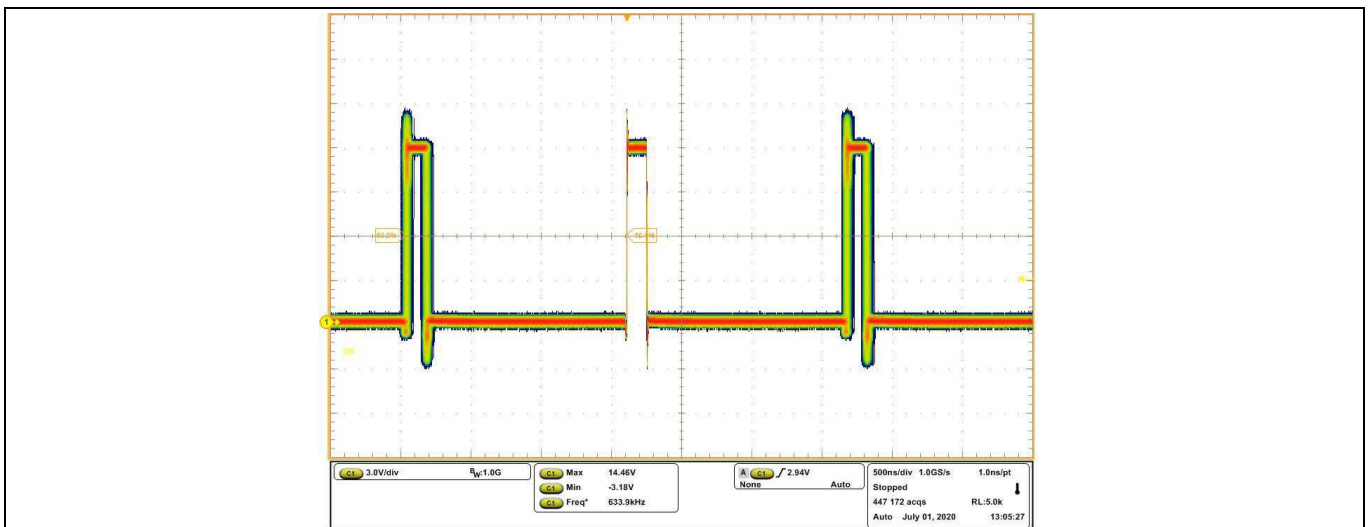

Figure 19 SW node, 20 A load, fsw = 600 kHz

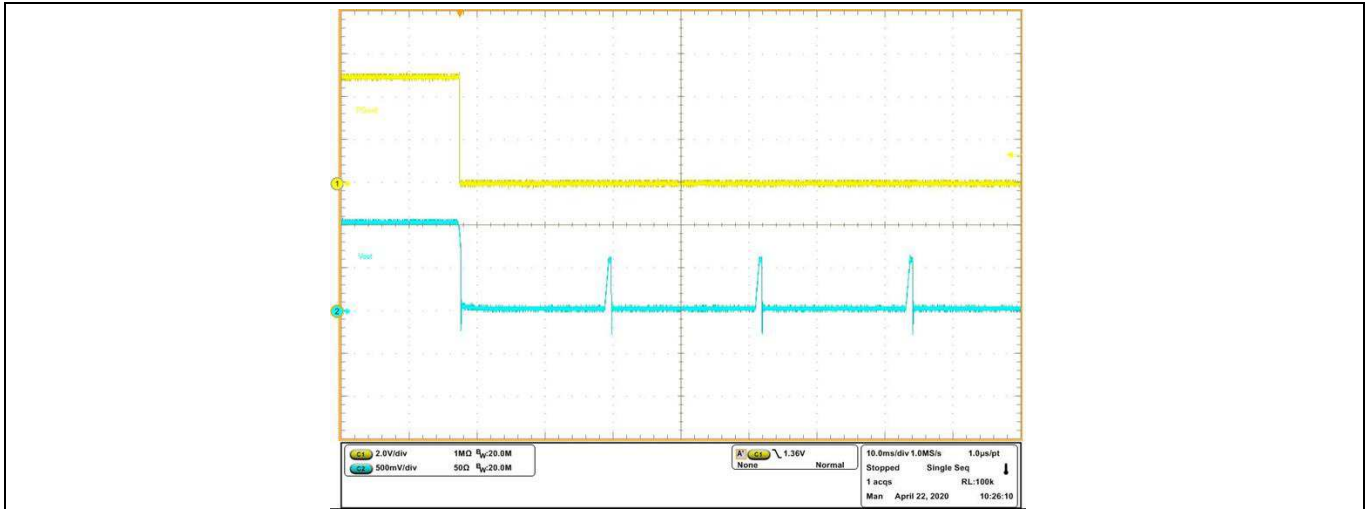

Figure 20 Short circuit and UVP (Hiccup), (Ch2: V_o , Ch1: P_{Good})

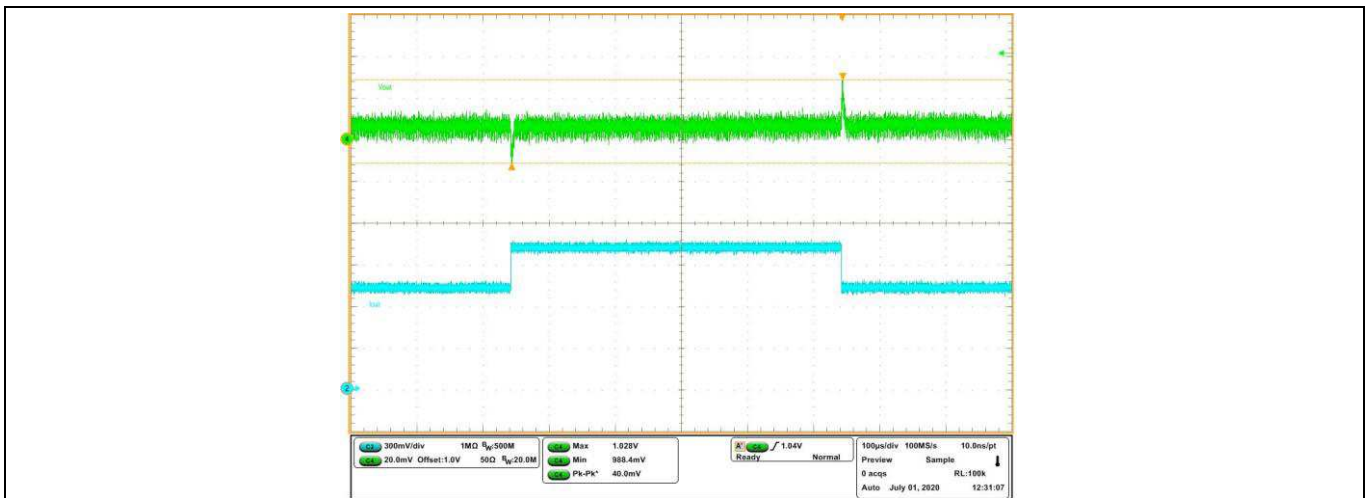

Figure 21 Transient response at 6 A step load current at 30 A/ μ s slew rate: $I_{out} = 14$ to 20 A (Ch4: V_{out} , Ch2: I_{out} , 50 mV/A), pk-pk: 40 mV, $f_{sw} = 600$ kHz



Figure 22 Thermal image at 20 A load TDA38820 = 58°C, L = 49°C, $f_{sw} = 600$ kHz, $T_a = 25^\circ\text{C}$, natural convection

15 Layout Recommendations

PCB layout is very important when designing high frequency switching converters. Layout will affect noise pickup and can cause a good design to perform with less than expected results. Following design guidelines are recommended to achieve the best performance.

- Bypass capacitors, including input/output capacitors, Vin, and VCC bypass capacitors, should be placed near the corresponding pins as close as possible.
- Place bypass capacitors from TDA38820 power input (Drain of Control MOSFET) to PGND (Source of Synchronous MOSFET) to reduce noise and ringing in the system. The output capacitors should be terminated to a ground plane that is away from the input PGND to mitigate the switching spikes on the Vout. The bypass capacitor for VCC should be terminated to PGND.
- Place a boot strap capacitor near the TDA38820 BOOT and PHASE pin as close as possible to minimize the loop inductance.
- SW node copper should only be routed on the top layer to minimize the impact of switching noises
- Connect AGND pin to the PGND pad through a single point connection. On the TDA38820 demo board, AGND pin is connected to the exposed PGND pad with a copper trace.
- Via holes can be placed on PVIN and PGND pads to aid thermal dissipation.
- Wide copper polygons are desired for PVin and PGND connections in favor of power losses reduction and thermal dissipation. Sufficient via holes should be used to connect power traces between different layers.
- Single-ended V_o sensing is often used for local sensing. To implement this configuration, following design guidelines should be followed, as illustrated in [Figure 23](#).
 - The output voltage can be sensed from a high-frequency bypass capacitor of 0.1 μF or higher, through a 15 mil PCB trace.
 - Keep the Vout sense line away from any noise sources and shield the sense line with ground planes.
 - The sense trace is connected to a feedback resistor divider with the lower resistor terminated at VSENM pin.
 - Short VSENM pin and AGND pin with a short trace.
- If it is required to sense the output voltage at a remote location, pseudo remoting sensing can be implemented as follows. The configuration is also shown in [Figure 24](#).
 - A pair of PCB traces with at least 15 mil trace width, running close to each other and away from any noise sources such as inductor and SW nodes, should be used to implement Kelvin sensing of the voltage across a high bypass capacitor of 0.1 μF or higher.
 - The ground connection of the remote sensing signal must be terminated at VSENM pin.
 - The Vout connection of the remote sensing signal must be connected to the feedback resistor divider with the lower feedback resistor terminated at VSENM pin.
 - Shield the pair of remote sensing lines with ground planes above and below.
 - Do **NOT** connect VSENM pin and AGND pin in this configuration
- The EN pin and configuration pins including SS/LATCH, TON/MODE, and ILIM should be terminated to a quiet ground. On the TDA38820 standard demo board, they are terminated to the PGND copper plane away from the power current flow. Alternatively, they can be terminated to a dedicated AGND PCB trace.

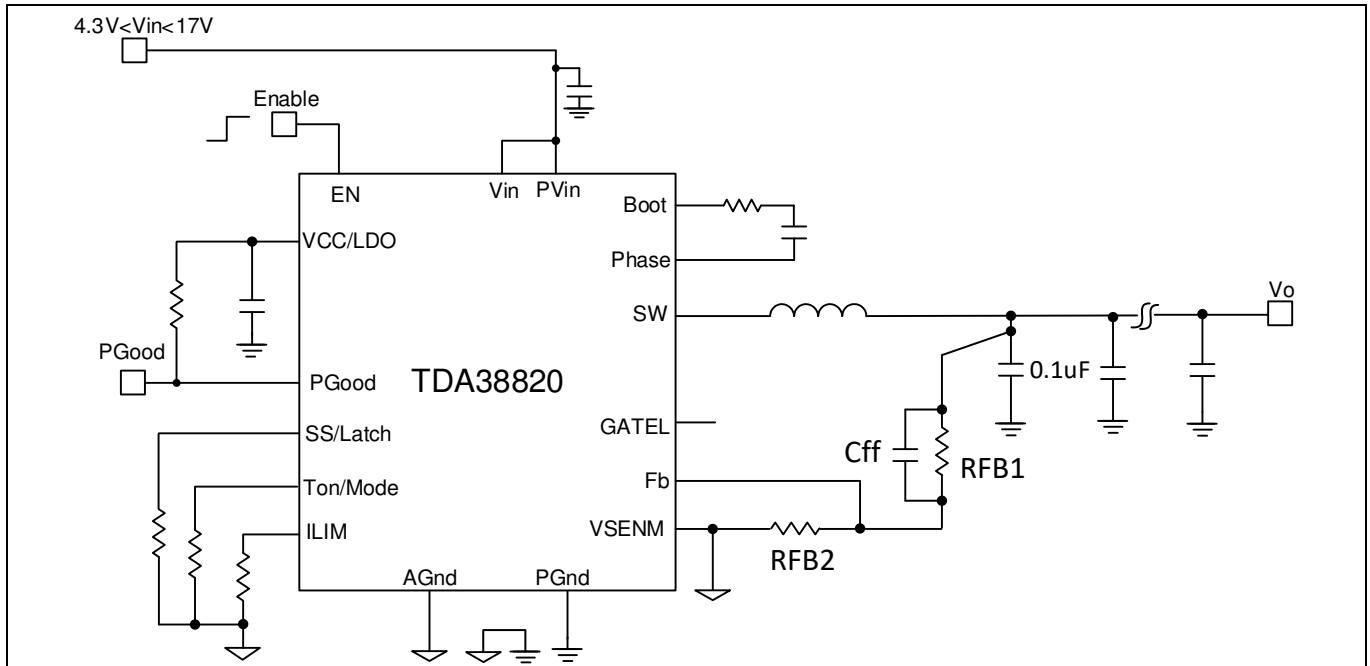

Figure 23 Single-ended V_o local sense configuration

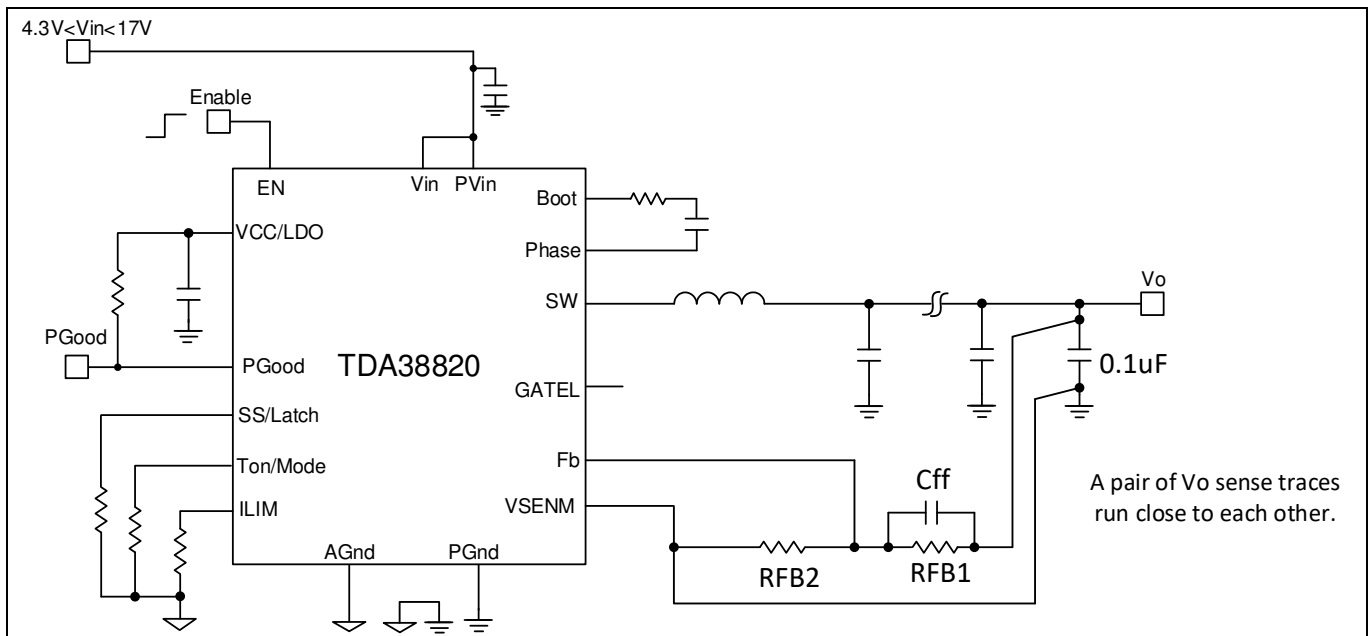

Figure 24 Pseudo remote V_o sense configuration

TDA38820 OptiMOS™ IPOL
20 A single-voltage synchronous Buck regulator
Layout Recommendations



Following figures illustrate the PCB layout design of the TDA38820 standard demo board with pseudo remote V_o sense.

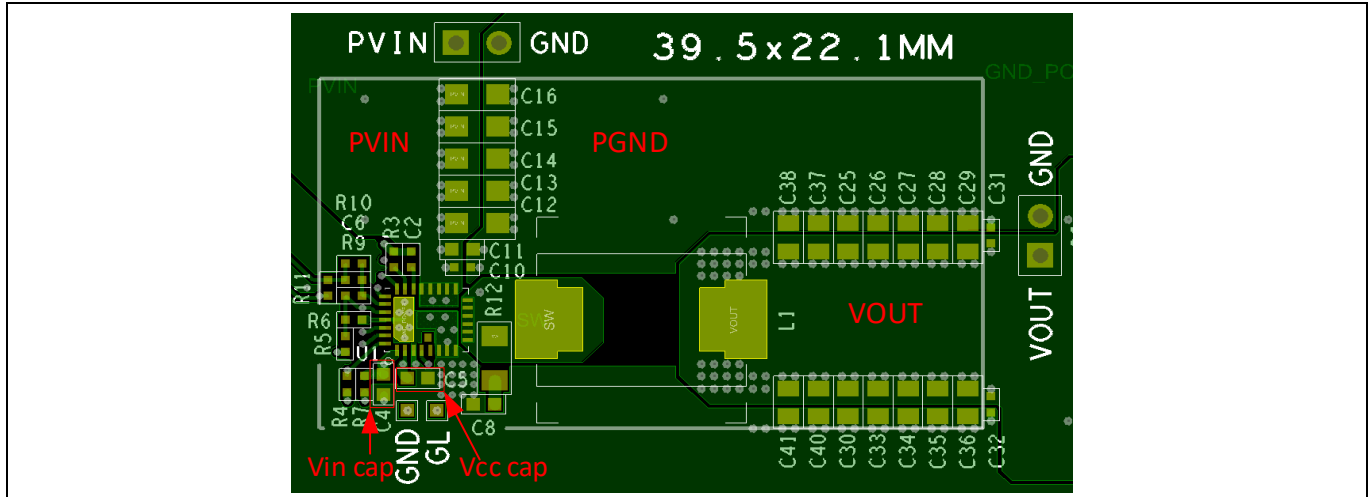

Figure 25 TDA38820 Demo Board – Top Layer

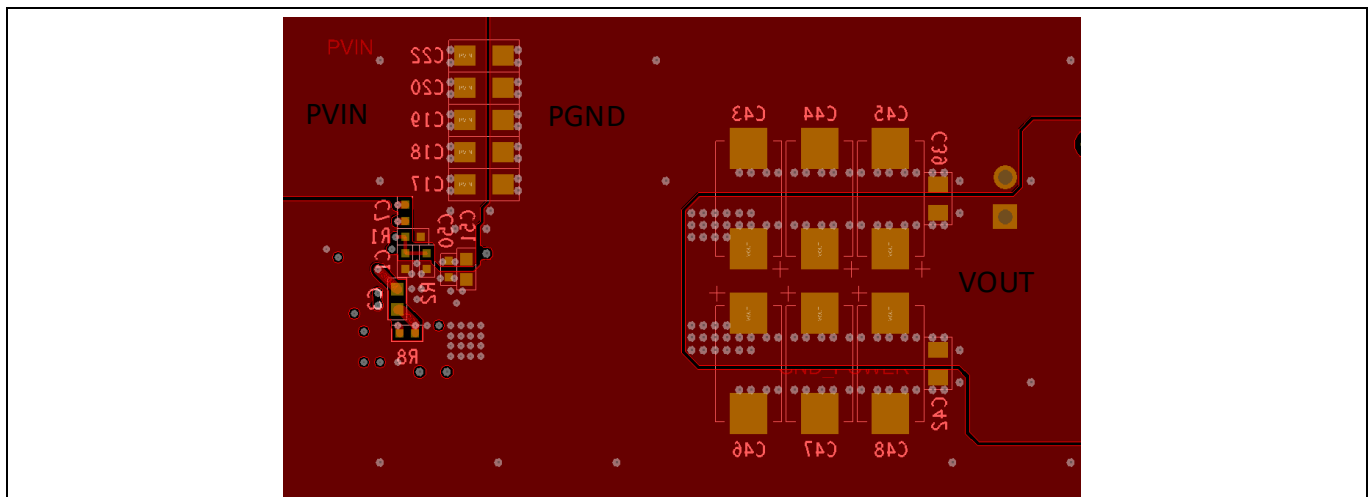

Figure 26 TDA38820 Demo Board – Bottom Layer

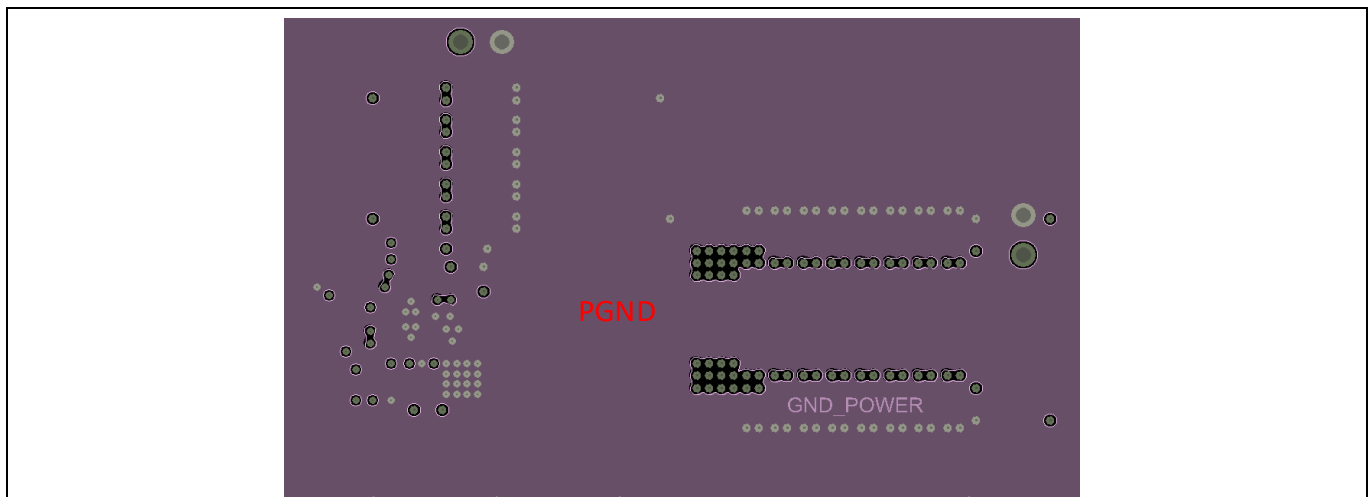

Figure 27 TDA38820 Demo Board – 2nd Layer (Ground)

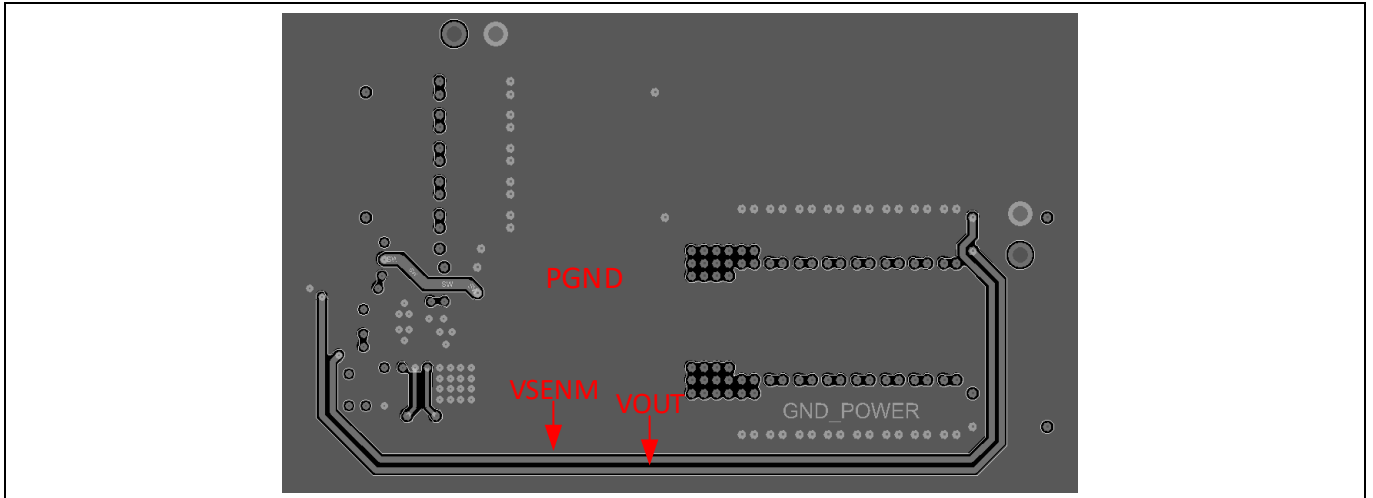

Figure 28 TDA38820 Demo Board – 3rd Layer (Ground & Signal)

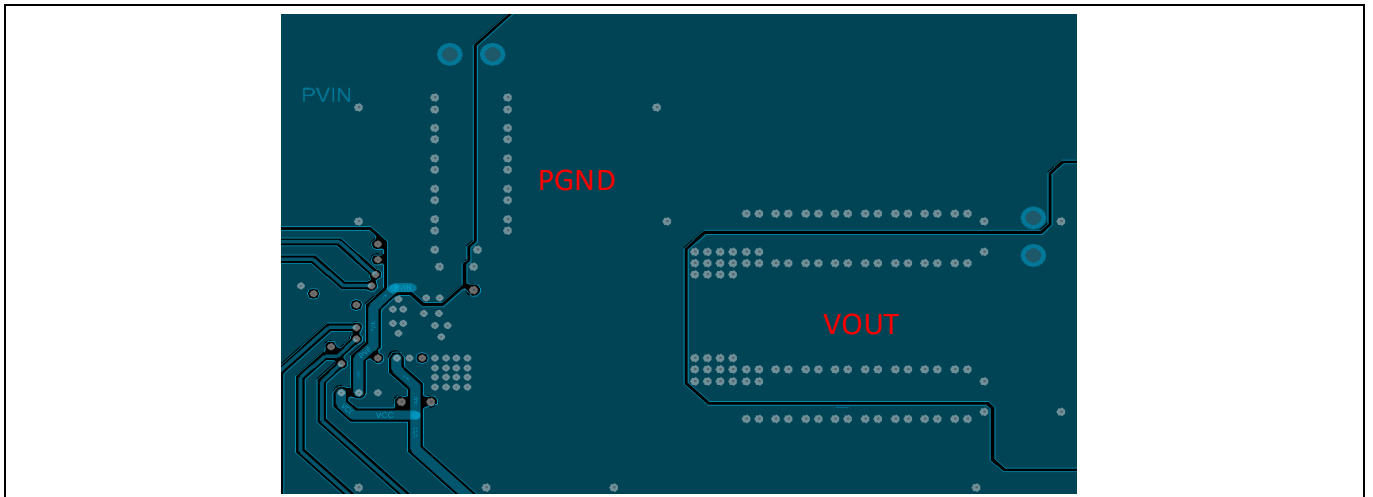

Figure 29 TDA38820 Demo Board – 4th Layer (Ground & Signal)

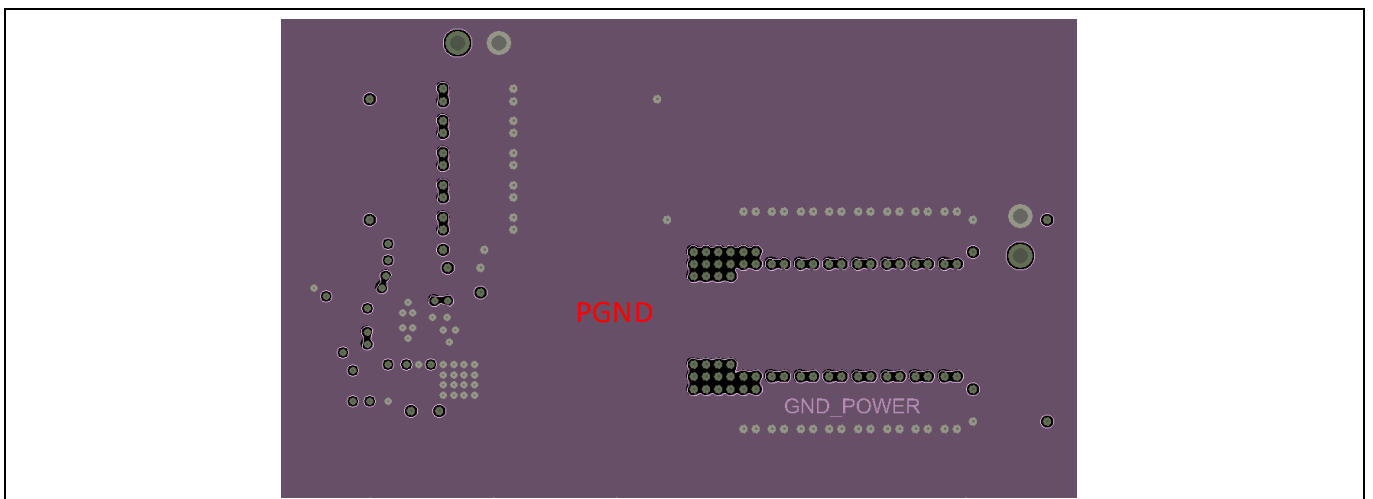

Figure 30 TDA38820 Demo Board – 5th Layer (Ground)

Layout Recommendations

15.1 Solder Mask

Evaluation has shown that the best overall performance is achieved using the substrate/PCB layout as shown in the following figures. PQFN devices should be placed to an accuracy of 0.050 mm on both X and Y axes. Self-centering behavior is highly dependent on solders and processes, and experiments should be run to confirm the limits of self-centering on specific processes.

Infineon recommends that larger Power or Land Area pads are Solder Mask Defined (SMD). This allows the underlying copper traces to be as large as possible, which helps in terms of current carrying capability and device cooling capability. When using SMD pads, the underlying copper traces should be at least 0.05 mm larger (on each edge) than the openings in the solder mask. This allows for layers to be misaligned by up to 0.1 mm on both axes. Ensure that the solder resist in-between the smaller signal lead areas is at least 0.15 mm wide, due to the high x/y aspect ratio of the solder mask strip.

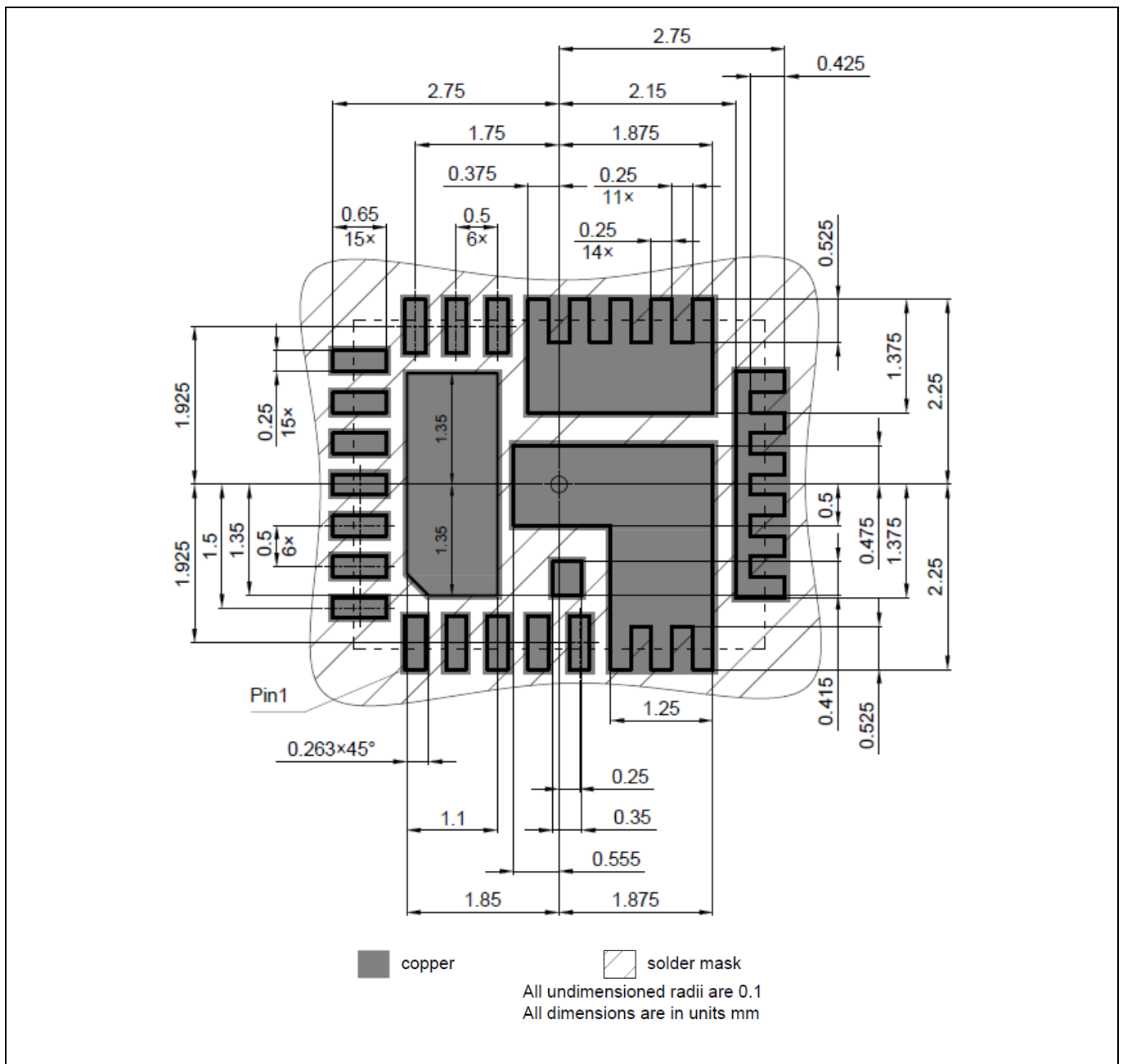

Figure 31 Solder mask (all dimensions in mm)

Layout Recommendations

15.2 Stencil Design

In most cases, the thickness of a stencil has to be matched to the needs of all components on the PCB. For typical integrated QFN or SON packages, stencils with a thickness of 100 µm to 120 µm are recommended. Further details and specific stencil design recommendations can be found in the application note [“Recommendations for Board Assembly of Infineon Integrated Packages without Leads”](#).

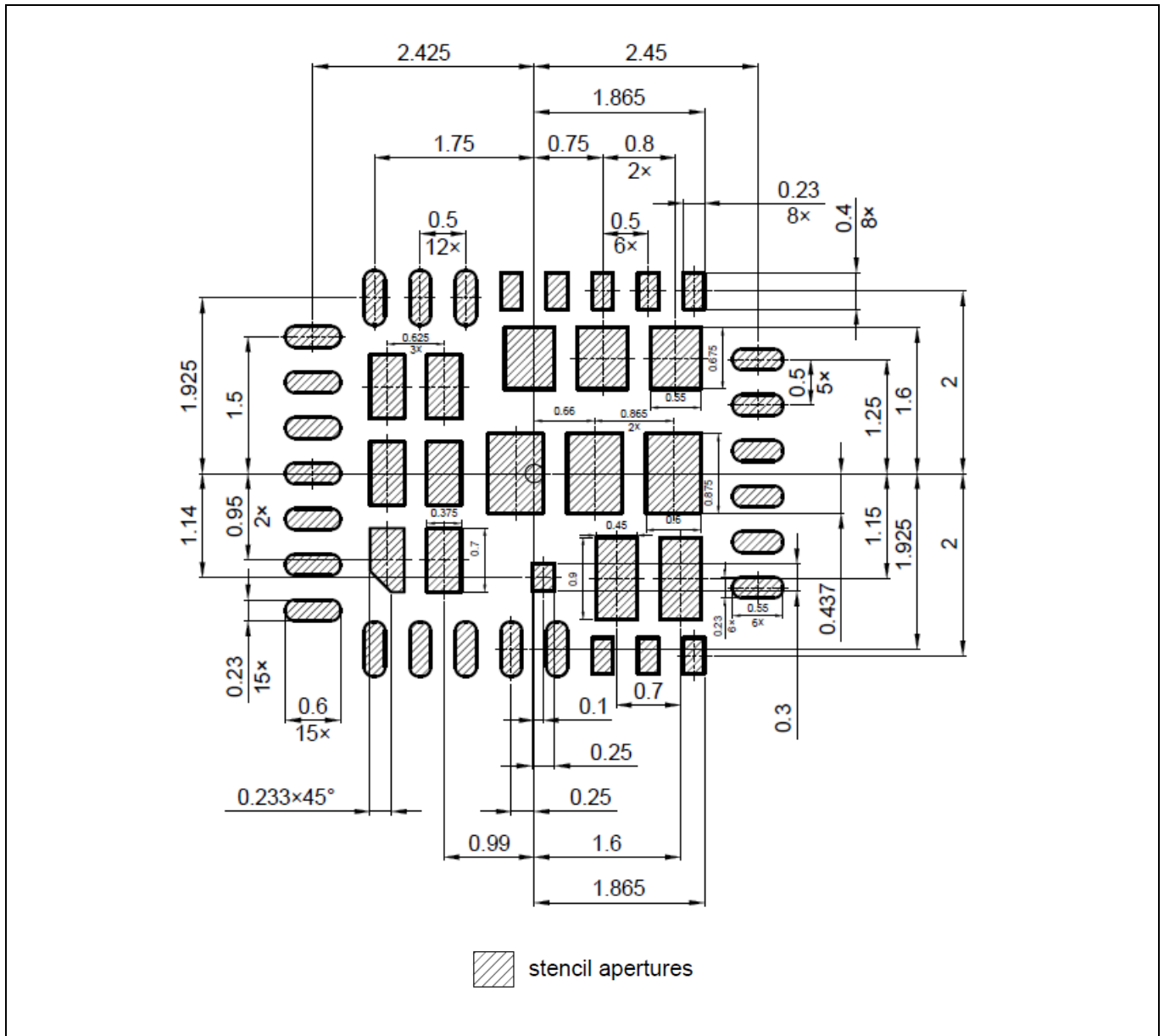

Figure 32 Stencil pad size and spacing (all dimensions in mm)

Package

16 Package

This section includes marking, mechanical and packaging information for the TDA38820.

16.1 Marking Information

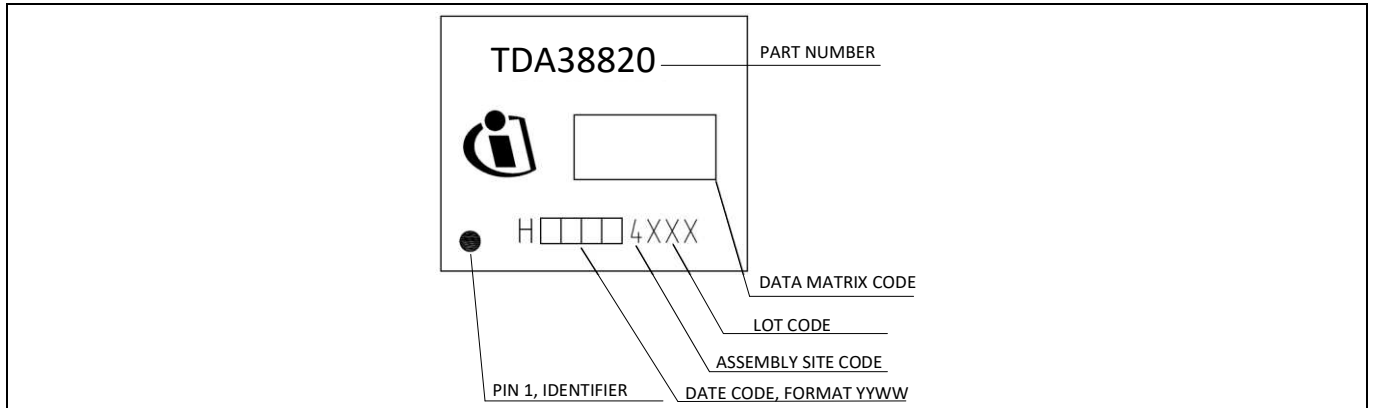
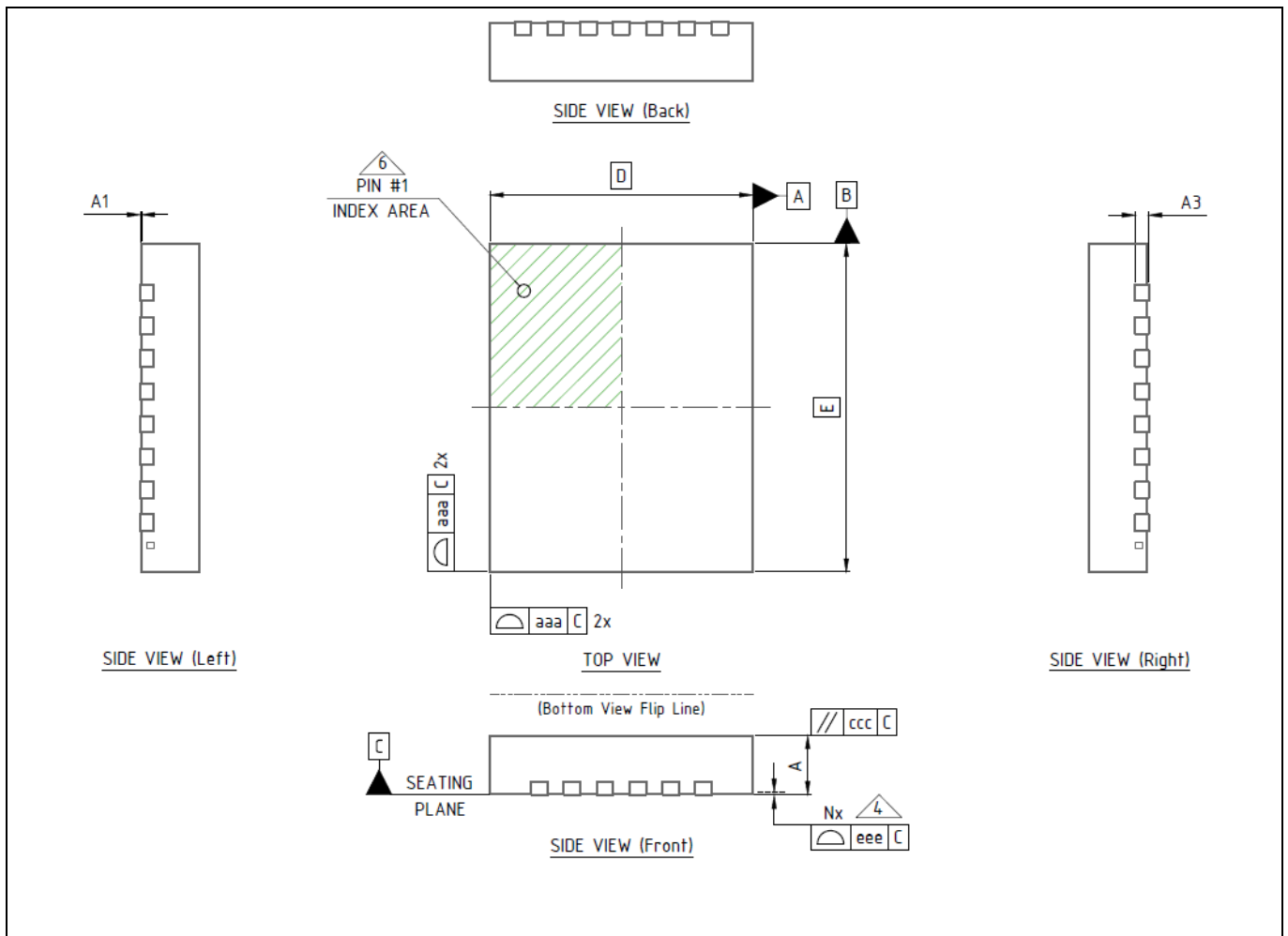

Figure 33 Package Marking

16.2 Dimensions



TDA38820 OptiMOS™ IPOL

20 A single-voltage synchronous Buck regulator



Package

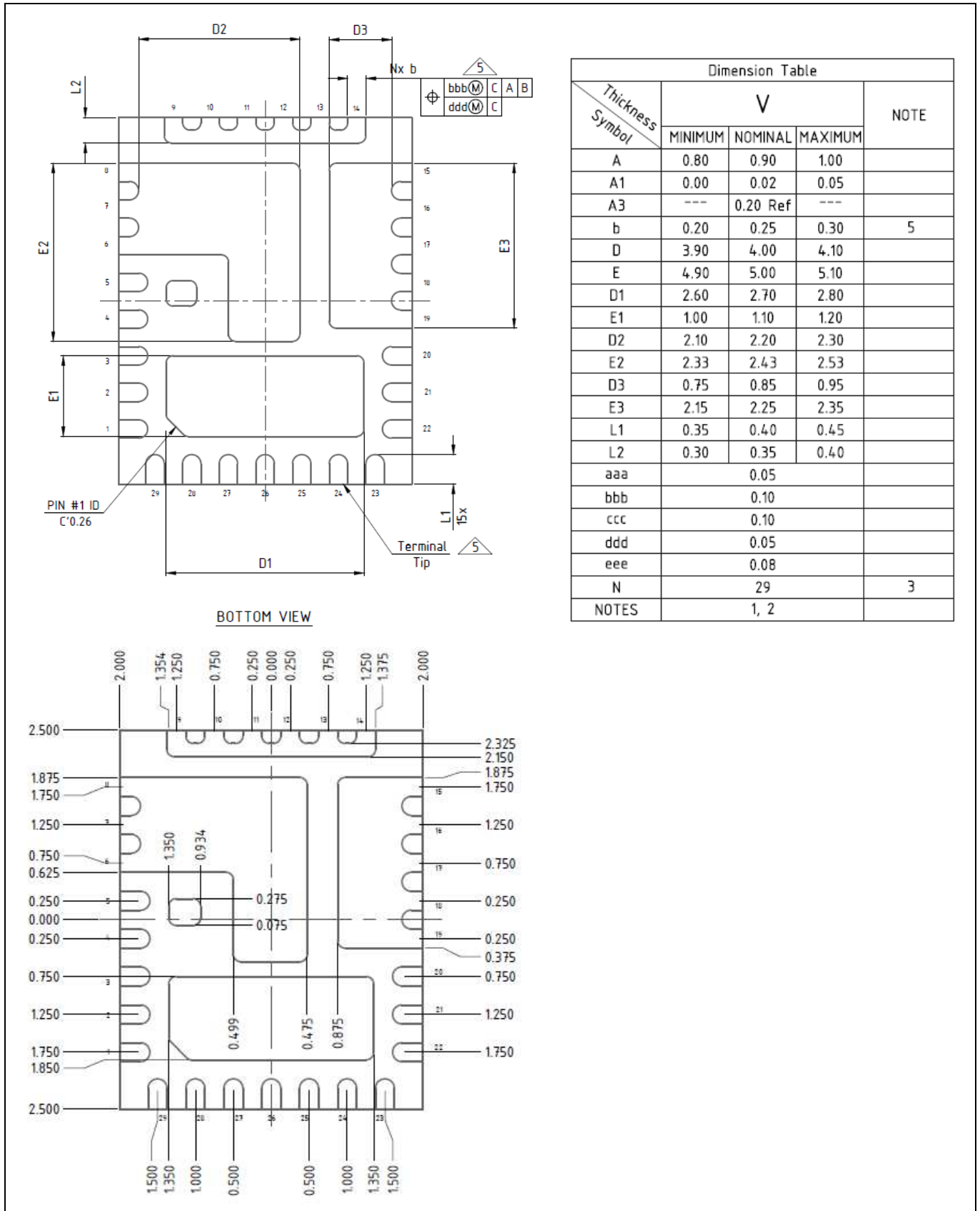

Figure 34 Package Dimensions (all dimensions in mm)

16.3 Tape and Reel Information

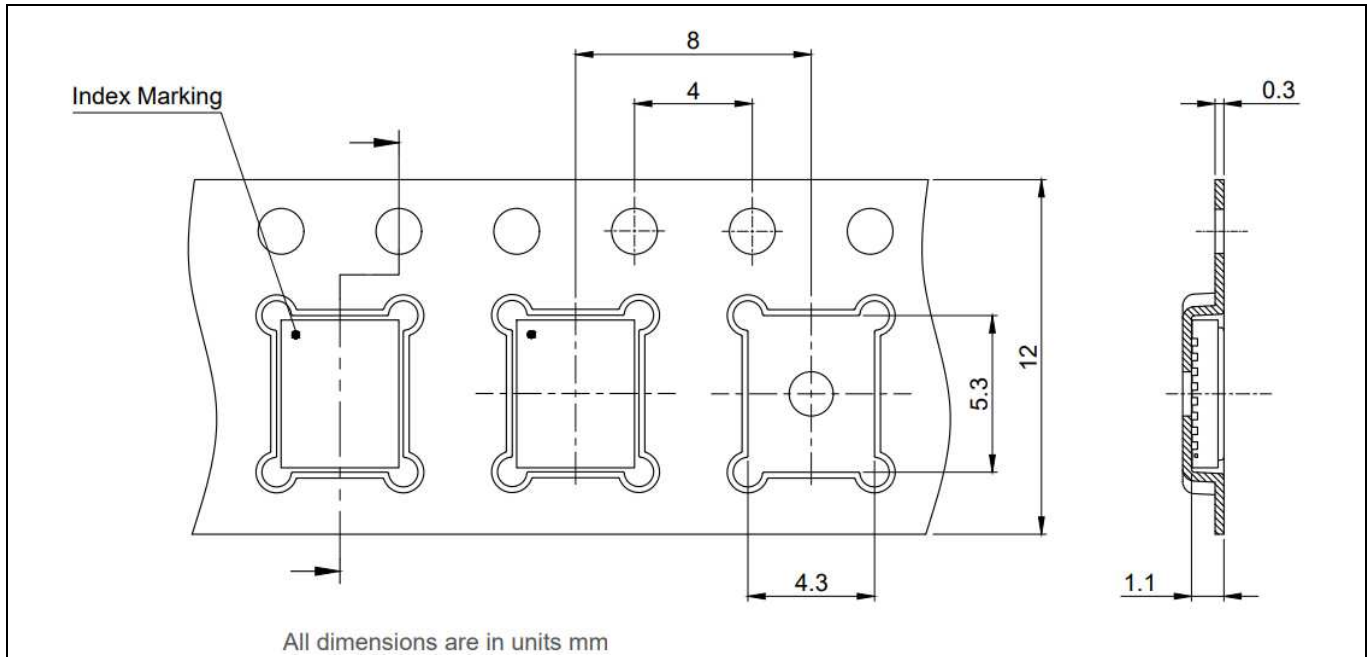

Figure 35 Pin 1 orientation in the tape

17 Environmental Qualifications

Qualification Level		Industrial
Moisture Sensitivity		QFN Package JEDEC Level 2 @ 260 °C
ESD	Human Body Model	ANSI/ESDA/JEDEC JS-001, 2 (2000 V to < 4000 V)
	Charged Device Model	ANSI/ESDA/JEDEC JS-002, C3 (≥ 1000 V)
RoHS2 Compliant		This product is in compliance with EU Directive 2015/863/EU amending Annex II to EU Directive 2011/65/EU (RoHS) and contains Pb according RoHS exemption 7a, Lead in high melting temperature type solders.

18 Evaluation Boards and Support Documentation

Table 9 TDA38820 Evaluation Boards and User Guides

Evaluation board	Specifications	Website Address
EVAL_38820_1Vout	12 V±10%, 1 V, 20 A	www.infineon.com/EVAL_38820_1Vout

Table 10 TDA38820 Package Information

Device	Package Type	Website Address
TDA38820	PG-IQFN-29-1	https://www.infineon.com/cms/en/product/packages/PG-IQFN

Revision History

TDA38820

Revision: 2022-04-13, Rev. 2.5

Previous Revision

Revision	Date	Subjects (major changes since last revision)
2.0	2021-01-22	Release of final version
2.1	2021-02-25	Add figure 7, 8 and thermal characteristics in section 6.1. Update figure 6. Update ordering information
2.2	2021-03-02	Correct revision date
2.3	2021-04-17	1) Add max Vout of 6V to the recommended operating conditions; (2) Update note 8; (3) Add Fig 22.
2.4	2021-06-15	(1) Change test condition for OCP limit from VCC = 5V to Int LDO; (2) Correct typo in the VFB typical performance curve; (3) Update Table 7
2.5	2022-04-13	Update Fig 31, 32, 34, and 35

Trademarks

All referenced product or service names and trademarks are the property of their respective owners.

We Listen to Your Comments

Any information within this document that you feel is wrong, unclear or missing at all? Your feedback will help us to continuously improve the quality of this document. Please send your proposal (including a reference to this document) to: erratum@infineon.com

Published by
Infineon Technologies AG
81726 München, Germany
© 2022 Infineon Technologies AG
All Rights Reserved.

Legal Disclaimer

The information given in this document shall in no event be regarded as a guarantee of conditions or characteristics ("Beschaffheitsgarantie").

With respect to any examples, hints or any typical values stated herein and/or any information regarding the application of the product, Infineon Technologies hereby disclaims any and all warranties and liabilities of any kind, including without limitation warranties of non-infringement of intellectual property rights of any third party.

In addition, any information given in this document is subject to customer's compliance with its obligations stated in this document and any applicable legal requirements, norms and standards concerning customer's products and any use of the product of Infineon Technologies in customer's applications.

The data contained in this document is exclusively intended for technically trained staff. It is the responsibility of customer's technical departments to evaluate the suitability of the product for the intended application and the completeness of the product information given in this document with respect to such application.

Information

For further information on technology, delivery terms and conditions and prices please contact your nearest Infineon Technologies Office (www.infineon.com).



Warnings

Due to technical requirements, components may contain dangerous substances. For information on the types in question, please contact the nearest Infineon Technologies Office.



The Infineon Technologies component described in this Data Sheet may be used in life-support devices or systems and/or automotive, aviation and aerospace applications or systems only with the express written approval of Infineon Technologies, if a failure of such components can reasonably be expected to cause the failure of that life-support, automotive, aviation and aerospace device or system or to affect the safety or effectiveness of that device or system. Life support devices or systems are intended to be implanted in the human body or to support and/or maintain and sustain and/or protect human life. If they fail, it is reasonable to assume that the health of the user or other persons may be endangered.

Looking for pricing, stock, or lifecycle information?

Click below to explore more details on WIN SOURCE:

-  [View TDA38820AUMA1](#) on WIN SOURCE
-  [Infineon Technologies](#) Information

Optimize Your Supply Chain with WIN SOURCE Solutions

-  Global Sourcing Solution
-  Obsolete Management
-  Cost Control Management
-  Shortage Management
-  Alternative Solution
-  Excess Inventory Management