



**THE DATASHEET OF
8SLVD1208-33NBGI**



General Description

The IDT8SLVD1208-33I is a high-performance differential LVDS fanout buffer. The device is designed for the fanout of high-frequency, very low additive phase-noise clock and data signals. The IDT8SLVD1208-33I is characterized to operate from a 3.3V power supply. Guaranteed output-to-output and part-to-part skew characteristics make the IDT8SLVD1208-33I ideal for those clock distribution applications demanding well-defined performance and repeatability. Two selectable differential inputs and eight low skew outputs are available. The integrated bias voltage reference enables easy interfacing of single-ended signals to the device inputs. The device is optimized for low power consumption and low additive phase noise.

Features

- Eight low skew, low additive jitter LVDS output pairs
- Two selectable, differential clock input pairs
- Differential PCLK, nPCLK pairs can accept the following differential input levels: LVDS, LVPECL
- Maximum input clock frequency: 2GHz (maximum)
- LVC MOS/LVTTL interface levels for the control select input
- Output skew: 8ps (typical)
- Propagation delay: 240ps (typical)
- Low additive phase jitter, RMS; $f_{REF} = 156.25\text{MHz}$, $V_{PP} = 1\text{V}$, 10kHz - 20MHz: 82fs (typical)
- Maximum device current consumption (I_{DD}): 190mA (maximum) @ 3.465V
- 3.3V supply voltage
- Lead-free (RoHS 6), 28-Lead VFQFN package
- -40°C to 85°C ambient operating temperature

Pin Assignment

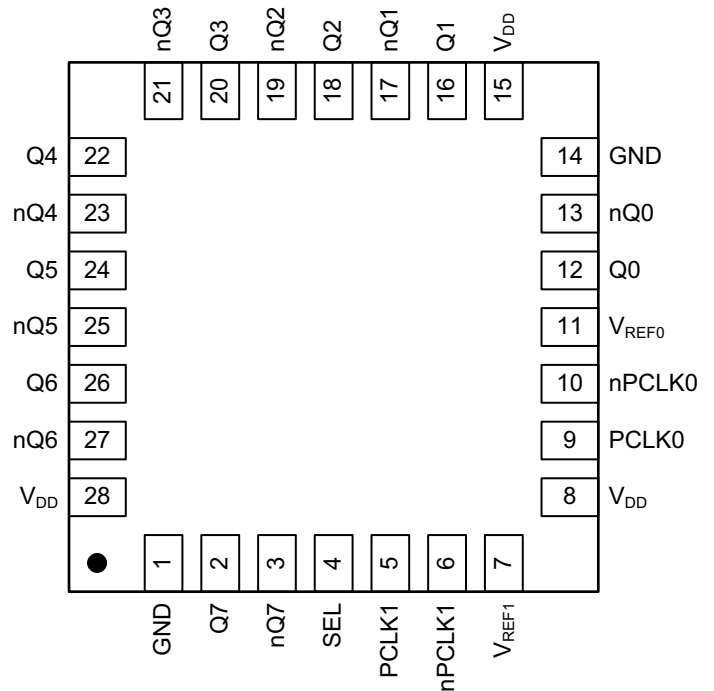

IDT8SLVD1208-33I

28 lead VFQFN

5.0mm x 5.0mm x 0.925mm package body

E-Pad size 3.25mm x 3.25 mm

NB Package

Top View

Block Diagram

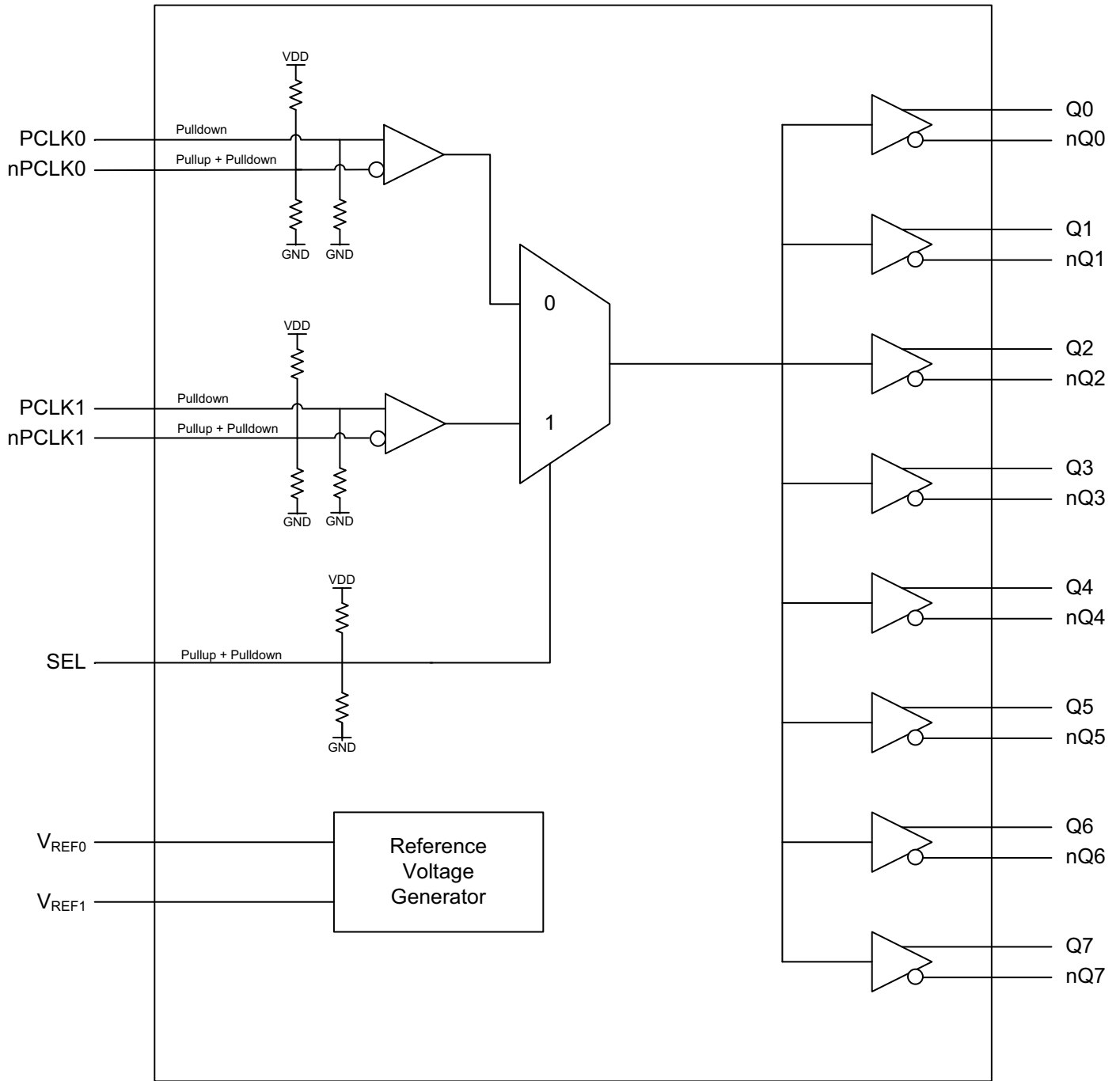

Pin Descriptions and Characteristics

Table 1. Pin Descriptions

Number	Name	Type		Description
1,14	GND	Power		Power supply pin.
4	SEL	Input	Pullup/ Pulldown	Reference select control pin. See Table 3 for function. LVCMOS/LVTTL interface levels.
5	PCLK1	Input	Pulldown	Non-inverting differential clock/data input.
6	nPCLK1	Input	Pullup/ Pulldown	Inverting differential clock/data input. $V_{DD}/2$ default when left floating.
8,15,28	V_{DD}	Power		Power supply pin.
9	PCLK0	Input	Pulldown	Non-inverting differential clock/data input.
10	nPCLK0	Input	Pullup/ Pulldown	Inverting differential clock/data input. $V_{DD}/2$ default when left floating.
11	V_{REF0}	Output		Bias voltage reference for the PCLK0, nPCLK0 inputs.
7	V_{REF1}	Output		Bias voltage reference for the PCLK1, nPCLK1 inputs.
12, 13	Q0, nQ0	Output		Differential clock output pair. LVDS interface levels.
16, 17	Q1, nQ1	Output		Differential clock output pair. LVDS interface levels.
18, 19	Q2, nQ2	Output		Differential clock output pair. LVDS interface levels.
20, 21	Q3, nQ3	Output		Differential clock output pair. LVDS interface levels.
22, 23	Q4, nQ4	Output		Differential clock output pair. LVDS interface levels.
24, 25	Q5, nQ5	Output		Differential clock output pair. LVDS interface levels.
26, 27	Q6, nQ6	Output		Differential clock output pair. LVDS interface levels.
2, 3	Q7, nQ7	Output		Differential clock output pair. LVDS interface levels.

NOTE: *Pulldown* and *Pullup* refers to internal input resistors. See Table 2, *Pin Characteristics*, for typical values.

Table 2. Pin Characteristics

Symbol	Parameter	Test Conditions	Minimum	Typical	Maximum	Units
C_{IN}	Input Capacitance			2		pF
$R_{PULLDOWN}$	Input Pulldown Resistor			51		k Ω
R_{PULLUP}	Input Pullup Resistor			51		k Ω

Function Table

Table 3. SEL Input Selection Function Table

Input	Operation
0	PCLK0, nPCLK0 is the selected differential clock input.
1	PCLK1, nPCLK1 is the selected differential clock input.
Open	Input buffers are disabled and outputs are static.

NOTE: SEL is an asynchronous control.

Absolute Maximum Ratings

NOTE: Stresses beyond those listed under *Absolute Maximum Ratings* may cause permanent damage to the device. These ratings are stress specifications only. Functional operation of product at these conditions or any conditions beyond those listed in the *DC Characteristics* or *AC Characteristics* is not implied. Exposure to absolute maximum rating conditions for extended periods may affect product reliability.

Item	Rating
Supply Voltage, V_{DD}	4.6V
Inputs, V_I	-0.5V to $V_{DD} + 0.5V$
Outputs, I_O (LVPECL) Continuous Current Surge Current	10mA 15mA
Input Sink/Source, I_{REF}	$\pm 2mA$
Maximum Junction Temperature, $T_{J,MAX}$	125°C
Storage Temperature, T_{STG}	-65°C to 150°C
ESD - Human Body Model, NOTE 1	2000V
ESD - Charged Device Model, NOTE 1	1500V

NOTE 1: According to JEDEC/JS-001-2012/ 22-C101E.

DC Electrical Characteristics

Table 4A. Power Supply DC Characteristics, $V_{DD} = 3.3V \pm 5\%$, $T_A = -40^\circ C$ to $85^\circ C$

Symbol	Parameter	Test Conditions	Minimum	Typical	Maximum	Units
V_{DD}	Power Supply Voltage		3.135	3.3	3.465	V
I_{DD}	Power Supply Current	Q0 to Q7 terminated 100Ω between nQx, Qx		170	190	mA

Table 4B. LVCMOS/LVTTL DC Characteristics, $V_{DD} = 3.3V \pm 5\%$, $T_A = -40^\circ C$ to $85^\circ C$

Symbol	Parameter		Test Conditions	Minimum	Typical	Maximum	Units
V_{MID}	Input voltage - open pin		Open		$V_{DD} / 2$		V
V_{IH}	Input High Voltage	SEL		$0.7 * V_{DD}$		$V_{DD} + 0.3$	V
V_{IL}	Input Low Voltage	SEL		-0.3		$0.2 * V_{DD}$	V
I_{IH}	Input High Current	SEL	$V_{DD} = V_{IN} = 3.465V$			150	μA
I_{IL}	Input Low Current	SEL	$V_{DD} = 3.465V, V_{IN} = 0V$	-150			μA

Table 4C. Differential Inputs Characteristics, $V_{DD} = 3.3V \pm 5\%$, $T_A = -40^\circ C$ to $85^\circ C$

Symbol	Parameter		Test Conditions	Minimum	Typical	Maximum	Units
I_{IH}	Input High Current	PCLK0, nPCLK0 PCLK1, nPCLK1	$V_{IN} = V_{DD} = 3.465V$			150	μA
I_{IL}	Input Low Current	PCLK0, PCLK1	$V_{IN} = 0V, V_{DD} = 3.465V$	-10			μA
		nPCLK0, nPCLK1	$V_{IN} = 0V, V_{DD} = 3.465V$	-150			μA
V_{REF0}, V_{REF1}	Reference Voltage for Input Bias		$I_{REFx} = \pm 1mA$	$V_{DD} - 1.5$	$V_{DD} - 1.25$	$V_{DD} - 1.15$	V
V_{PP}	Peak-to-Peak Voltage; NOTE 1		$f_{REF} < 1.5 GHz$	0.1		1.5	V
			$f_{REF} > 1.5 GHz$	0.2		1.5	V
V_{CMR}	Common Mode Input Voltage; NOTE 1, 2			1.0		$V_{DD} - 0.6$	V

NOTE 1: V_{IL} should not be less than -0.3V.

NOTE 2: Common mode input voltage is defined as crosspoint voltage.

Table 4D. LVDS DC Characteristics, $V_{DD} = 3.3V \pm 5\%$, $T_A = -40^\circ C$ to $85^\circ C$

Symbol	Parameter	Test Conditions	Minimum	Typical	Maximum	Units
V_{OD}	Differential Output Voltage	Outputs loaded with 100Ω	247		454	mV
ΔV_{OD}	V_{OD} Magnitude Change				50	mV
V_{OS}	Offset Voltage		1.125		1.55	V
ΔV_{OS}	V_{OS} Magnitude Change				50	mV

AC Electrical Characteristics

Table 5. AC Electrical Characteristics, $V_{DD} = 3.3V \pm 5\%$, $T_A = -40^\circ C$ to $85^\circ C$

Symbol	Parameter		Test Conditions	Minimum	Typical	Maximum	Units
f_{REF}	Input Frequency	PCLK[0:1], nPCLK[0:1]				2	GHz
$\Delta V/\Delta t$	Input Edge Rate	PCLK[0:1], nPCLK[0:1]		1.5			V/ns
t_{PD}	Propagation Delay; NOTE 1		PCKx, nPCKx to any Qx, nQx for $V_{PP} = 0.1V$ or $0.3V$	150	240	330	ps
$t_{sk(o)}$	Output Skew; NOTE 2, 3					40	ps
$t_{sk(i)}$	Input Skew; NOTE 3					60	ps
$t_{sk(p)}$	Pulse Skew		$f_{REF} = 100MHz$			25	ps
$t_{sk(pp)}$	Part-to-Part Skew; NOTE 3, 4					230	ps
t_{JIT}	Buffer Additive Phase Jitter, RMS; refer to Additive Phase Jitter Section		$f_{REF} = 122.88MHz$ Square Wave, $V_{PP} = 1V$, Integration Range: 1kHz – 40MHz		134	185	fs
			$f_{REF} = 122.88MHz$ Square Wave, $V_{PP} = 1V$, Integration Range: 10kHz – 20MHz		102	140	fs
			$f_{REF} = 122.88MHz$ Square Wave, $V_{PP} = 1V$, Integration Range: 12kHz – 20MHz		102	140	fs
			$f_{REF} = 156.25MHz$ Square Wave, $V_{PP} = 1V$, Integration Range: 1kHz – 40MHz		112	190	fs
			$f_{REF} = 156.25MHz$ Square Wave, $V_{PP} = 1V$, Integration Range: 10kHz – 20MHz		82	150	fs
			$f_{REF} = 156.25MHz$ Square Wave, $V_{PP} = 1V$, Integration Range: 12kHz – 20MHz		82	150	fs
			$f_{REF} = 156.25MHz$ Square Wave, $V_{PP} = 0.5V$, Integration Range: 1kHz – 40MHz		103	160	fs
			$f_{REF} = 156.25MHz$ Square Wave, $V_{PP} = 0.5V$, Integration Range: 10kHz – 20MHz		78	150	fs
			$f_{REF} = 156.25MHz$ Square Wave, $V_{PP} = 0.5V$, Integration Range: 12kHz – 20MHz		78	150	fs
t_R / t_F	Output Rise/ Fall Time		20% to 80% outputs loaded with 100Ω	30	100	300	ps
$MUX_{ISOLATION}$	Mux Isolation; NOTE 5		$f_{REF} = 100MHz$		-82		dB

NOTE: Electrical parameters are guaranteed over the specified ambient operating temperature range, which is established when the device is mounted in a test socket with maintained transverse airflow greater than 500 lpm. The device will meet specifications after thermal equilibrium has been reached under these conditions.

NOTE 1: Measured from the differential input crosspoint to the differential output crosspoint.

NOTE 2: Defined as skew between outputs at the same supply voltage and with equal load conditions. Measured at the differential crosspoint.

NOTE 3: This parameter is defined in accordance with JEDEC Standard 65.

NOTE 4: Defined as skew between outputs on different devices operating at the same supply voltage, same frequency, same temperature and with equal load conditions. Using the same type of inputs on each device, the outputs are measured at the differential crosspoint.

NOTE 5: Qx, nQx outputs measured differentially. See *MUX Isolation diagram* in the *Parameter Measurement Information section*.

Typical Phase Noise at 122.88MHz

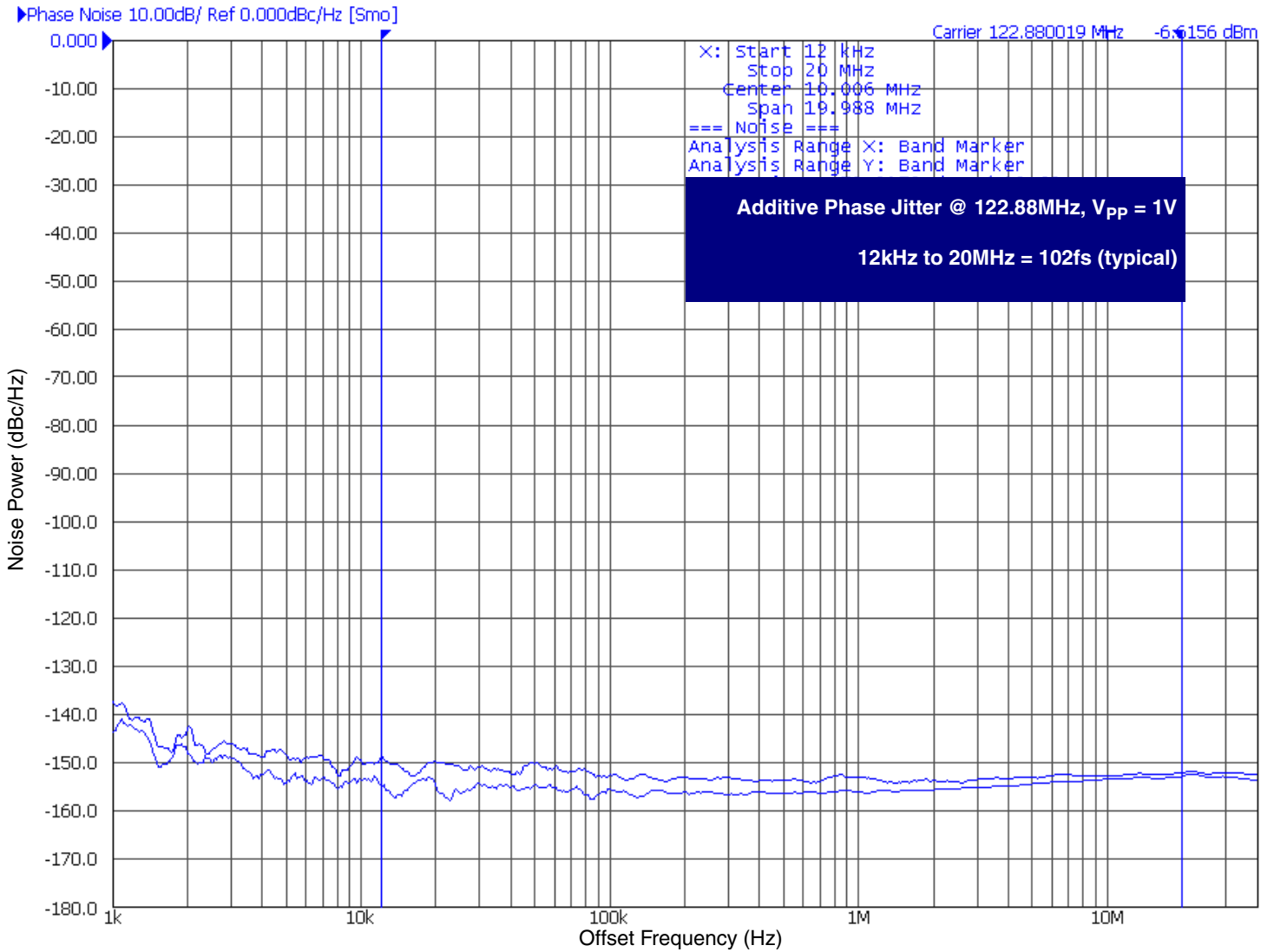

Typical Phase Noise at 156.25MHz

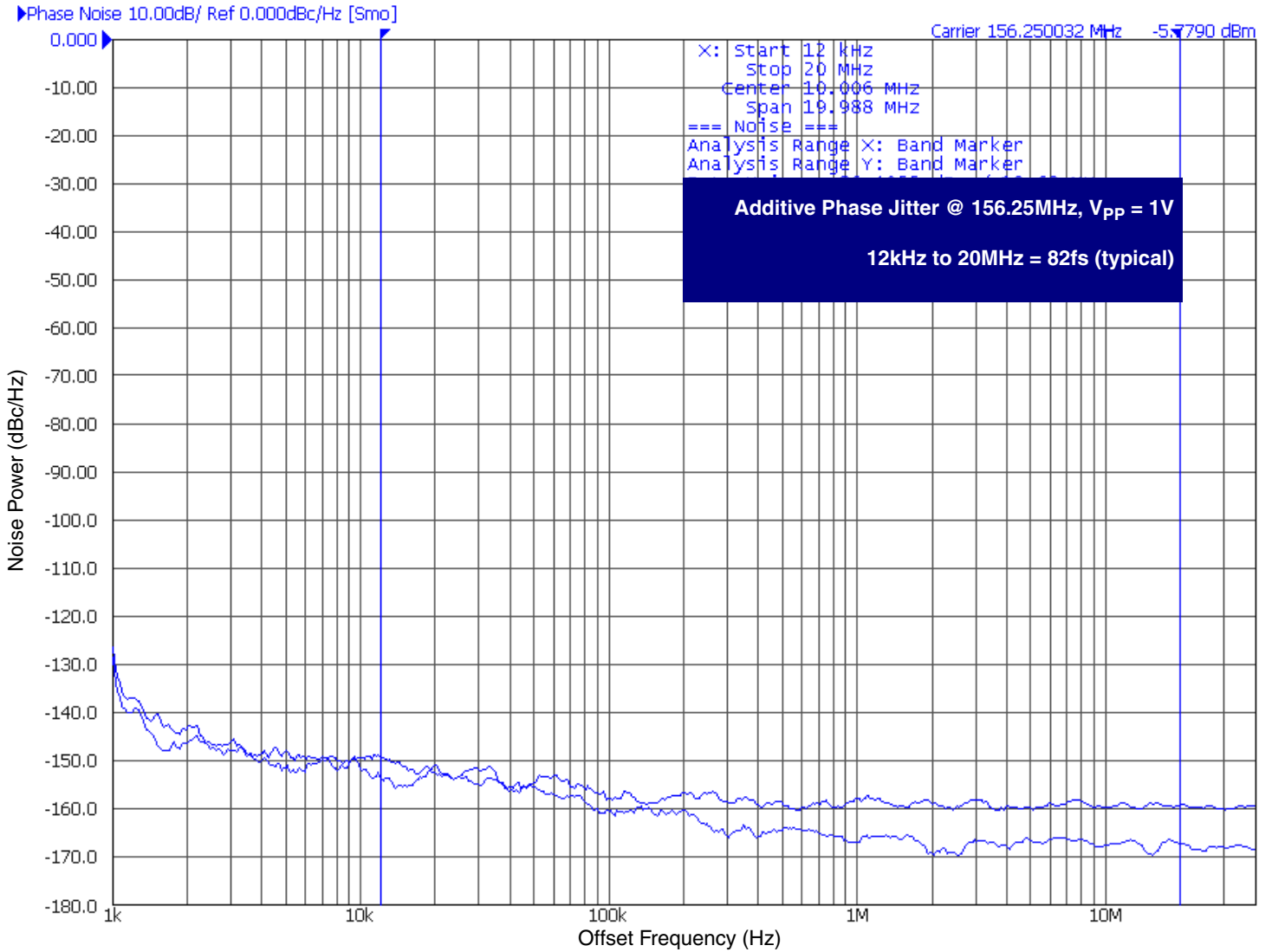

Typical Phase Noise at 156.25MHz

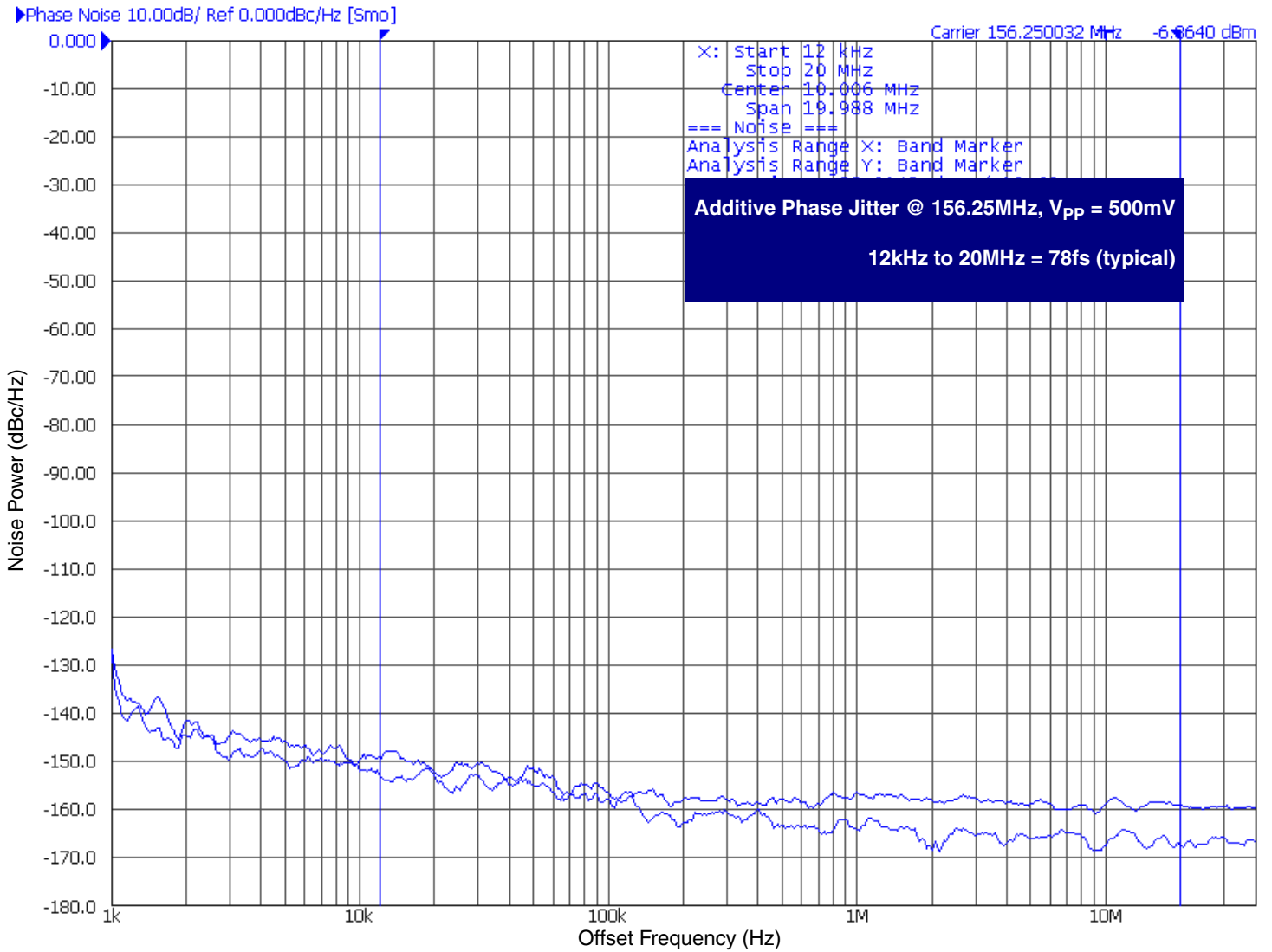

Parameter Measurement Information

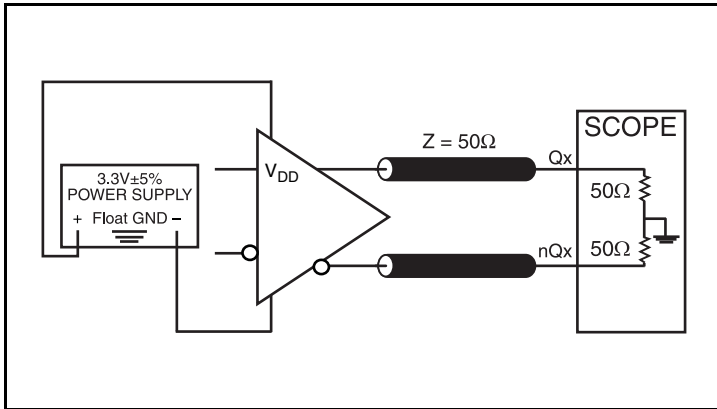

3.3V LVDS Output Load Test Circuit

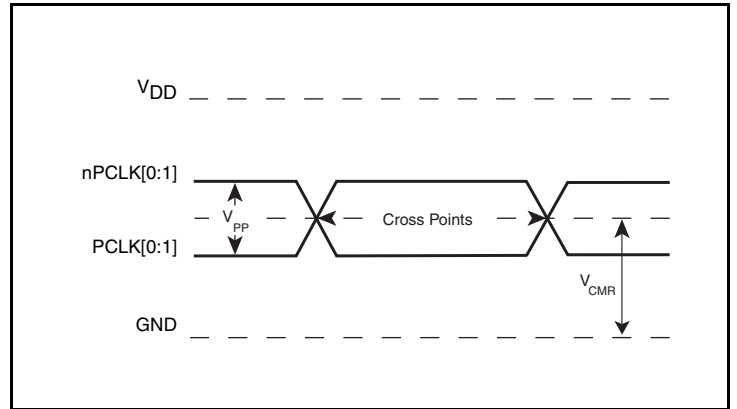

Differential Input Level

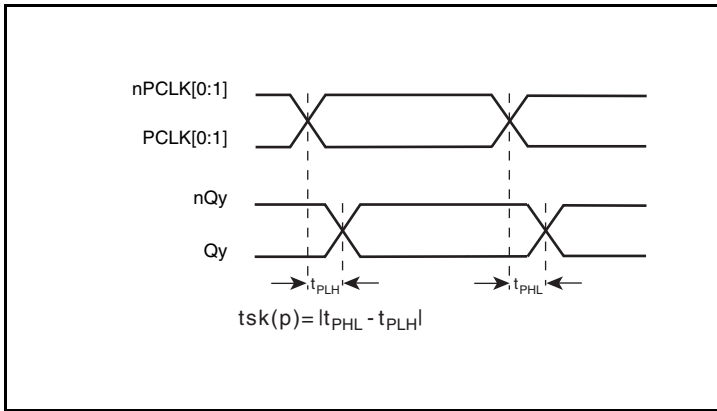

Pulse Skew

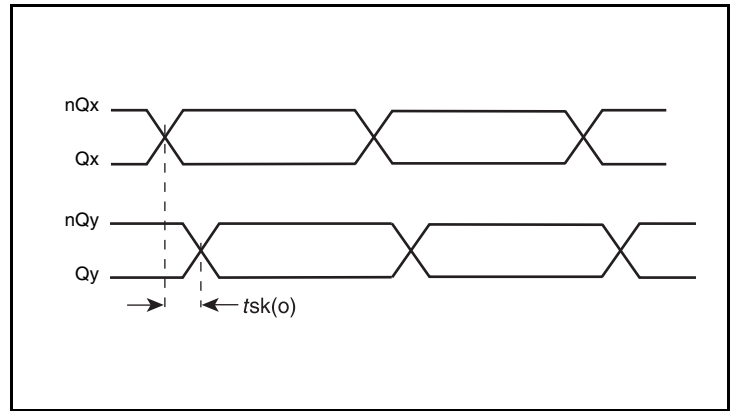

Output Skew

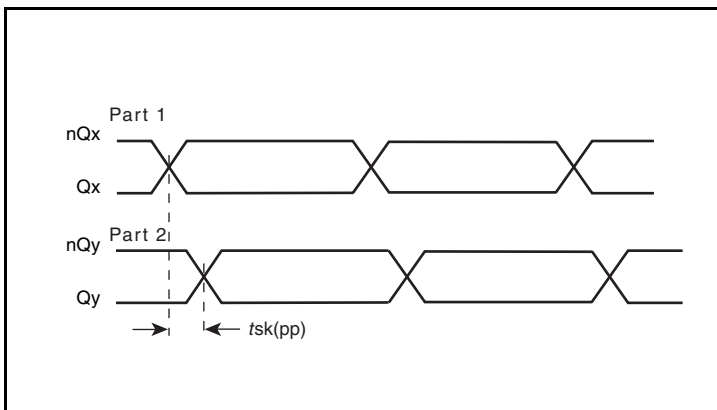

Part-to-Part Skew

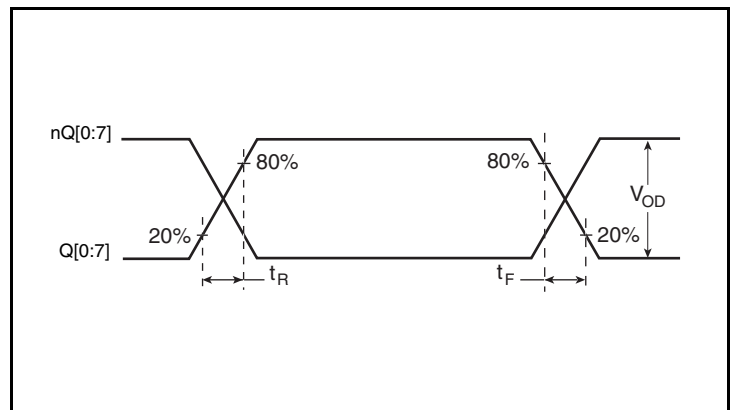

Output Rise/Fall Time

Parameter Measurement Information, continued

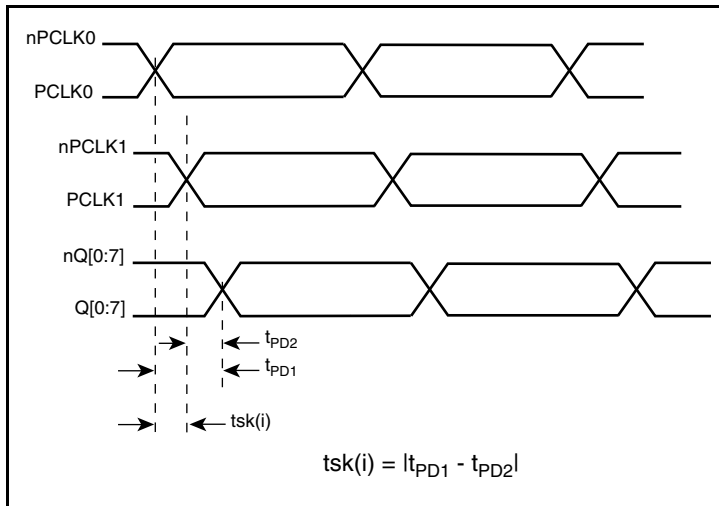

Input Skew

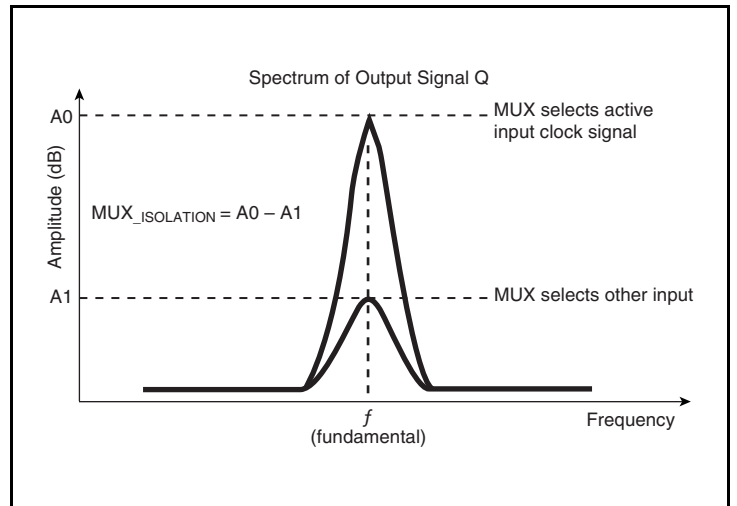

MUX Isolation

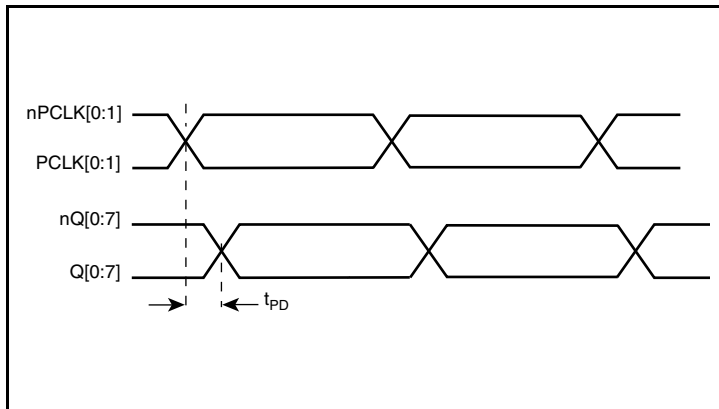

Propagation Delay

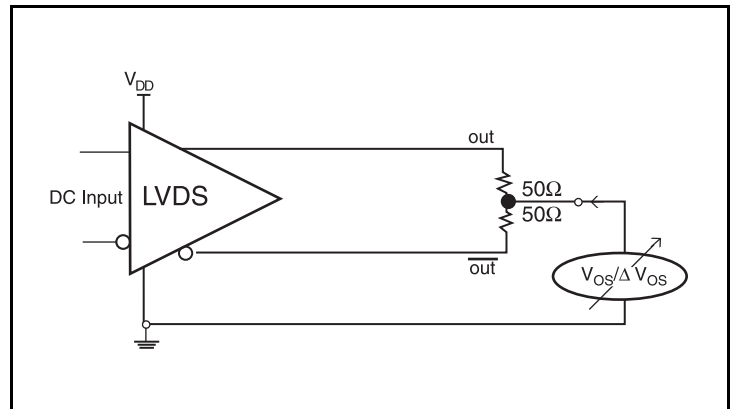

Offset Voltage Setup

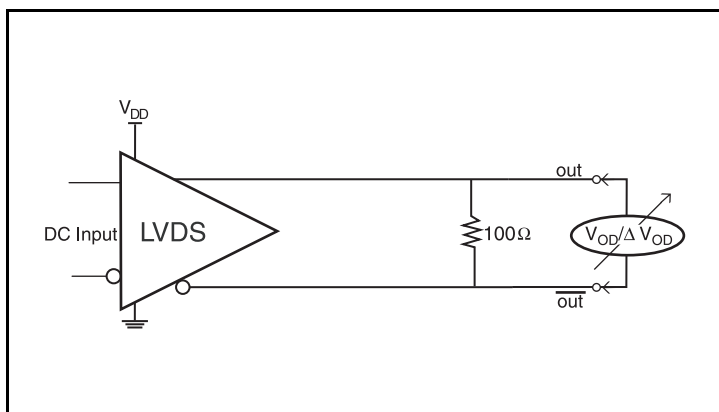

Differential Output Voltage Setup

Applications Information

Recommendations for Unused Input and Output Pins

Inputs:

PCLK/nPCLK Inputs

For applications not requiring the use of a differential input, both the PCLK and nPCLK pins can be left floating. Though not required, but for additional protection, a 1kΩ resistor can be tied from PCLK to ground.

Outputs:

LVDS Outputs

All unused LVDS output pairs can be either left floating or terminated with 100Ω across. If they are left floating, there should be no trace attached.

Wiring the Differential Input to Accept Single-Ended Levels

Figure 1 shows how a differential input can be wired to accept single ended levels. The reference voltage $V1 = V_{DD}/2$ is generated by the bias resistors R1 and R2. The bypass capacitor (C1) is used to help filter noise on the DC bias. This bias circuit should be located as close to the input pin as possible. The ratio of R1 and R2 might need to be adjusted to position the V1 in the center of the input voltage swing. For example, if the input clock swing is 2.5V and $V_{DD} = 2.5V$, R1 and R2 value should be adjusted to set V1 at 1.25V. The values below are for when both the single ended swing and V_{DD} are at the same voltage. This configuration requires that the sum of the output impedance of the driver (R_o) and the series resistance (R_s) equals the transmission line impedance. In addition, matched termination at the input will attenuate the signal in half. This can be done in one of two ways. First, R3 and R4 in parallel should equal the transmission

line impedance. For most 50Ω applications, R3 and R4 can be 100Ω. The values of the resistors can be increased to reduce the loading for slower and weaker LVCMOS driver. When using single-ended signaling, the noise rejection benefits of differential signaling are reduced. Even though the differential input can handle full rail LVCMOS signaling, it is recommended that the amplitude be reduced. The datasheet specifies a lower differential amplitude, however this only applies to differential signals. For single-ended applications, the swing can be larger, however V_{IL} cannot be less than -0.3V and V_{IH} cannot be more than $V_{DD} + 0.3V$. Though some of the recommended components might not be used, the pads should be placed in the layout. They can be utilized for debugging purposes. The datasheet specifications are characterized and guaranteed by using a differential signal.

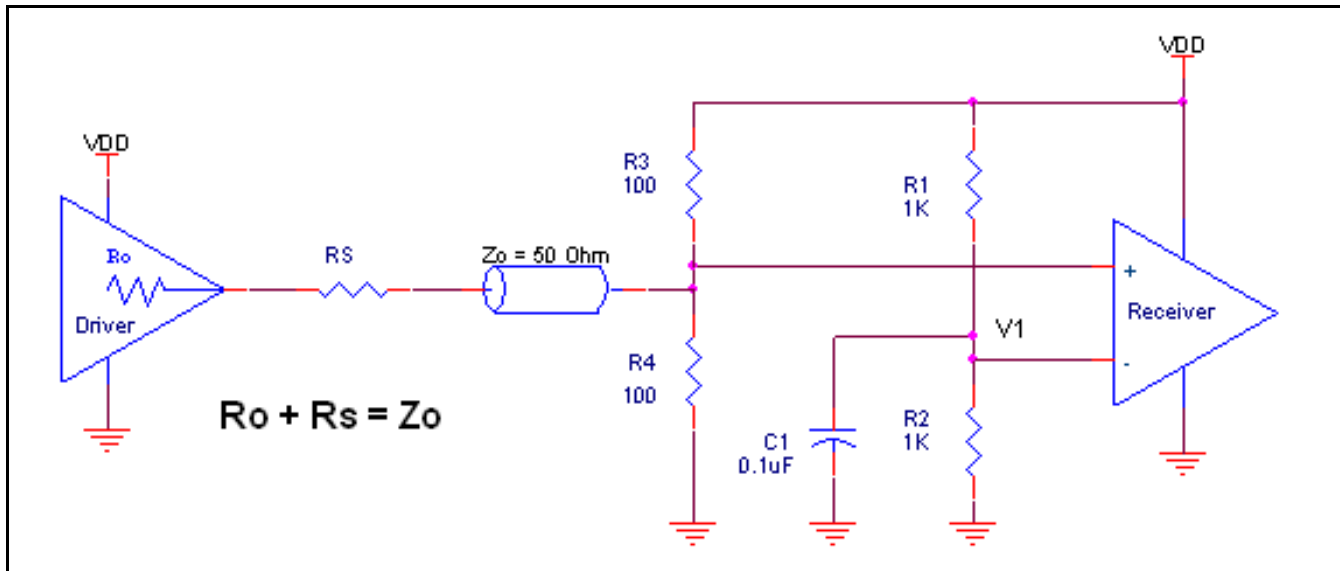

Figure 1. Recommended Schematic for Wiring a Differential Input to Accept Single-ended Levels

3.3V LVPECL Clock Input Interface

The PCLK /nPCLK accepts LVPECL, LVDS and other differential signals. Both differential outputs must meet the V_{PP} and V_{CMR} input requirements. Figures 2A to 2E show interface examples for the PCLK /nPCLK input driven by the most common driver types. The

input interfaces suggested here are examples only. If the driver is from another vendor, use their termination recommendation. Please consult with the vendor of the driver component to confirm the driver termination requirements.

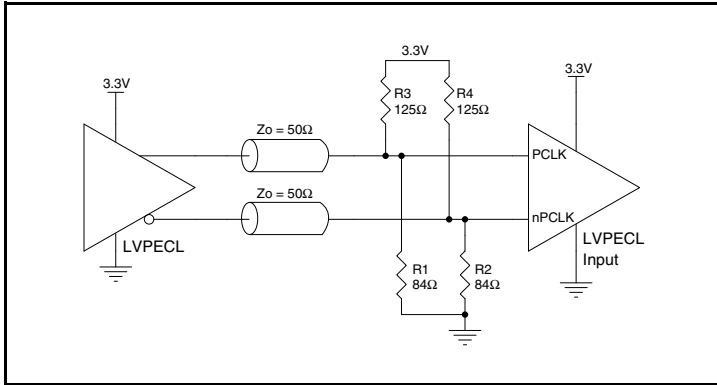

Figure 2A. PCLK/nPCLK Input Driven by a 3.3V LVPECL Driver

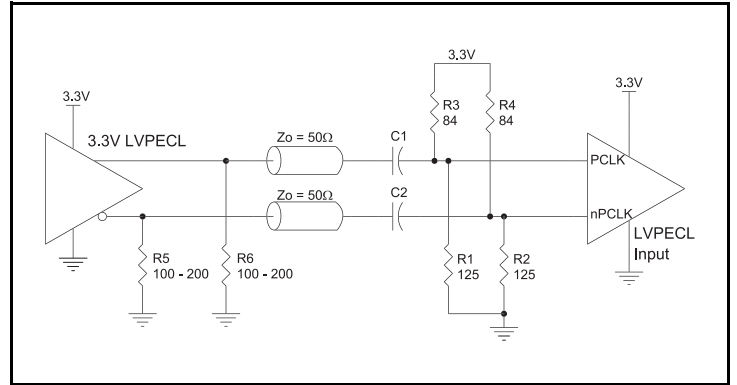

Figure 2B. PCLK/nPCLK Input Driven by a 3.3V LVPECL Driver with AC Couple

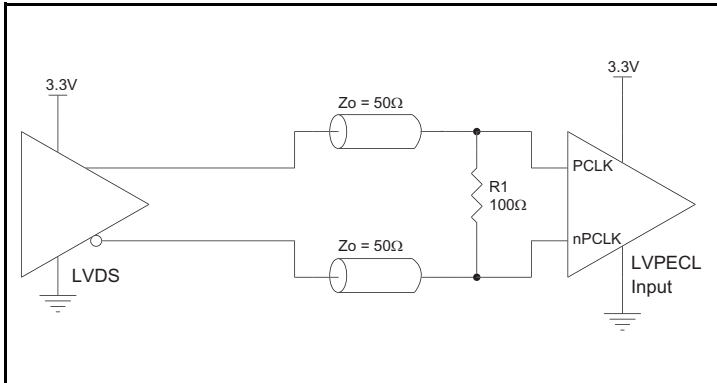

Figure 2C. PCLK/nPCLK Input Driven by a 3.3V LVDS Driver

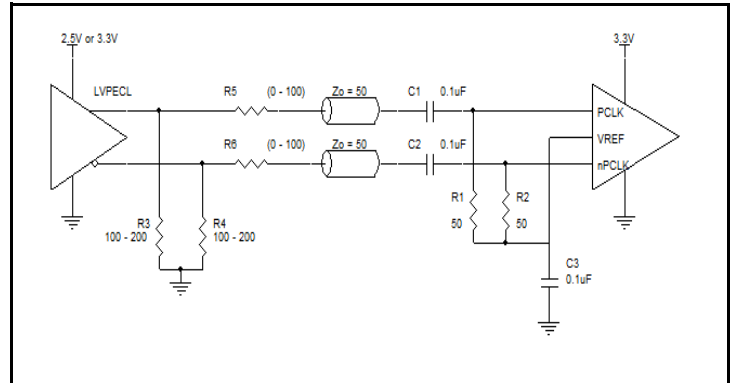

Figure 2D. PCLK/nPCLK Input Driven by a 3.3V LVPECL Driver with AC Coupling

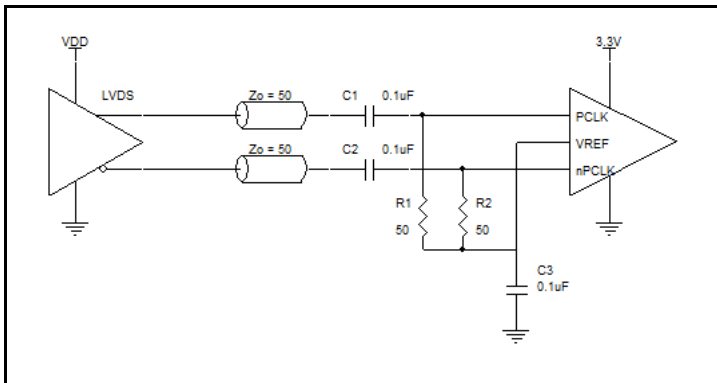
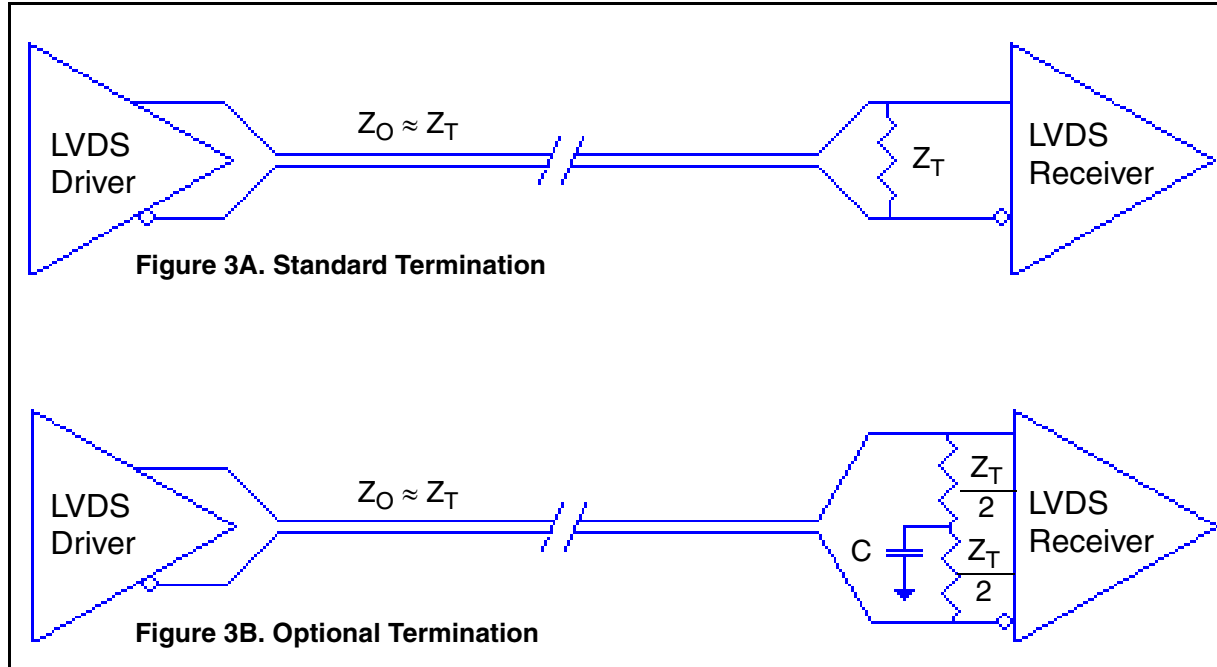

Figure 2E. PCLK/nPCLK Input Driven by a 3.3V LVDS Driver with AC Coupling

LVDS Driver Termination

For a general LVDS interface, the recommended value for the termination impedance (Z_T) is between 90Ω and 132Ω . The actual value should be selected to match the differential impedance (Z_0) of your transmission line. A typical point-to-point LVDS design uses a 100Ω parallel resistor at the receiver and a 100Ω differential transmission-line environment. In order to avoid any transmission-line reflection issues, the components should be surface mounted and must be placed as close to the receiver as possible. IDT offers a full line of LVDS compliant devices with two types of output structures: current source and voltage source. The

standard termination schematic as shown in *Figure 3A* can be used with either type of output structure. *Figure 3B*, which can also be used with both output types, is an optional termination with center tap capacitance to help filter common mode noise. The capacitor value should be approximately 50pF . If using a non-standard termination, it is recommended to contact IDT and confirm if the output structure is current source or voltage source type. In addition, since these outputs are LVDS compatible, the input receiver's amplitude and common-mode input range should be verified for compatibility with the output.



LVDS Termination

VFQFN EPAD Thermal Release Path

In order to maximize both the removal of heat from the package and the electrical performance, a land pattern must be incorporated on the Printed Circuit Board (PCB) within the footprint of the package corresponding to the exposed metal pad or exposed heat slug on the package, as shown in *Figure 4*. The solderable area on the PCB, as defined by the solder mask, should be at least the same size/shape as the exposed pad/slug area on the package to maximize the thermal/electrical performance. Sufficient clearance should be designed on the PCB between the outer edges of the land pattern and the inner edges of pad pattern for the leads to avoid any shorts.

While the land pattern on the PCB provides a means of heat transfer and electrical grounding from the package to the board through a solder joint, thermal vias are necessary to effectively conduct from the surface of the PCB to the ground plane(s). The land pattern must be connected to ground through these vias. The vias act as “heat pipes”. The number of vias (i.e. “heat pipes”) are application specific

and dependent upon the package power dissipation as well as electrical conductivity requirements. Thus, thermal and electrical analysis and/or testing are recommended to determine the minimum number needed. Maximum thermal and electrical performance is achieved when an array of vias is incorporated in the land pattern. It is recommended to use as many vias connected to ground as possible. It is also recommended that the via diameter should be 12 to 13mils (0.30 to 0.33mm) with 1oz copper via barrel plating. This is desirable to avoid any solder wicking inside the via during the soldering process which may result in voids in solder between the exposed pad/slug and the thermal land. Precautions should be taken to eliminate any solder voids between the exposed heat slug and the land pattern. Note: These recommendations are to be used as a guideline only. For further information, please refer to the Application Note on the Surface Mount Assembly of Amkor’s Thermally/Electrically Enhance Leadframe Base Package, Amkor Technology.

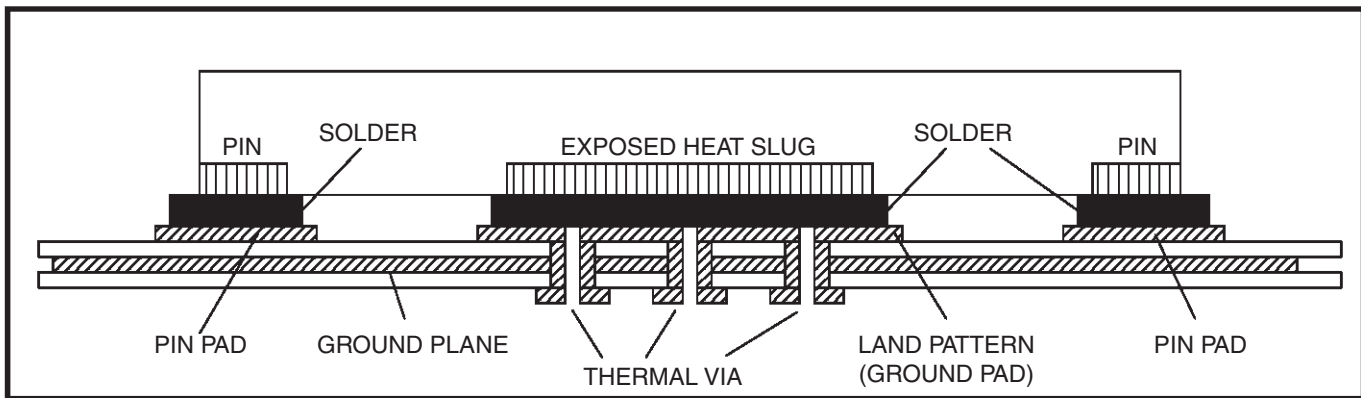

Figure 4. P.C. Assembly for Exposed Pad Thermal Release Path – Side View (drawing not to scale)

Power Considerations

This section provides information on power dissipation and junction temperature for the IDT8SLVD1208-33I. Equations and example calculations are also provided.

1. Power Dissipation.

The total power dissipation for the IDT8SLVD1208-33I is the sum of the core power plus the output power dissipation into the load. The following is the power dissipation for $V_{DD} = 3.3V + 5\% = 3.465V$, which gives worst case results.

The maximum current at 85°C is as follows:

$$I_{DD_MAX} = 190mA$$

- Power_{(core)MAX} = $V_{DD_MAX} * I_{DD_MAX} = 3.465V * 190mA = 658.4mW$

$$\text{Total Power}_{MAX} = 658.4mW$$

2. Junction Temperature.

Junction temperature, T_j , is the temperature at the junction of the bond wire and bond pad directly affects the reliability of the device. The maximum recommended junction temperature is 125°C. Limiting the internal transistor junction temperature, T_j , to 125°C ensures that the bond wire and bond pad temperature remains below 125°C.

The equation for T_j is as follows: $T_j = \theta_{JA} * Pd_total + T_A$

T_j = Junction Temperature

θ_{JA} = Junction-to-Ambient Thermal Resistance

Pd_total = Total Device Power Dissipation (example calculation is in section 1 above)

T_A = Ambient Temperature

In order to calculate junction temperature, the appropriate junction-to-ambient thermal resistance θ_{JA} must be used. Assuming no air flow and a multi-layer board, the appropriate value is 46.2°C/W per Table 6 below.

Therefore, T_j for an ambient temperature of 85°C with all outputs switching is:

$$85^\circ C + 0.658W * 46.2^\circ C/W = 115.4^\circ C. \text{ This is below the limit of } 125^\circ C.$$

This calculation is only an example. T_j will obviously vary depending on the number of loaded outputs, supply voltage, air flow and the type of board (multi-layer).

Table 6. Thermal Resistance θ_{JA} for 28 Lead VFQFN, Forced Convection

θ_{JA} at 0 Air Flow			
Meters per Second	0	1	2
Multi-Layer PCB, JEDEC Standard Test Boards	46.2°C/W	39.4C/W	37.1°C/W

Reliability Information

Table 7. θ_{JA} vs. Air Flow Table for a 28 Lead VFQFN

θ_{JA} at 0 Air Flow			
Meters per Second	0	1	2.5
Multi-Layer PCB, JEDEC Standard Test Boards	46.2°C/W	39.4C/W	37.1°C/W

Transistor Count

The transistor count for the IDT8SLVD1208-33I is: 489

28 Lead VFQFN Package Outline and Package Dimensions

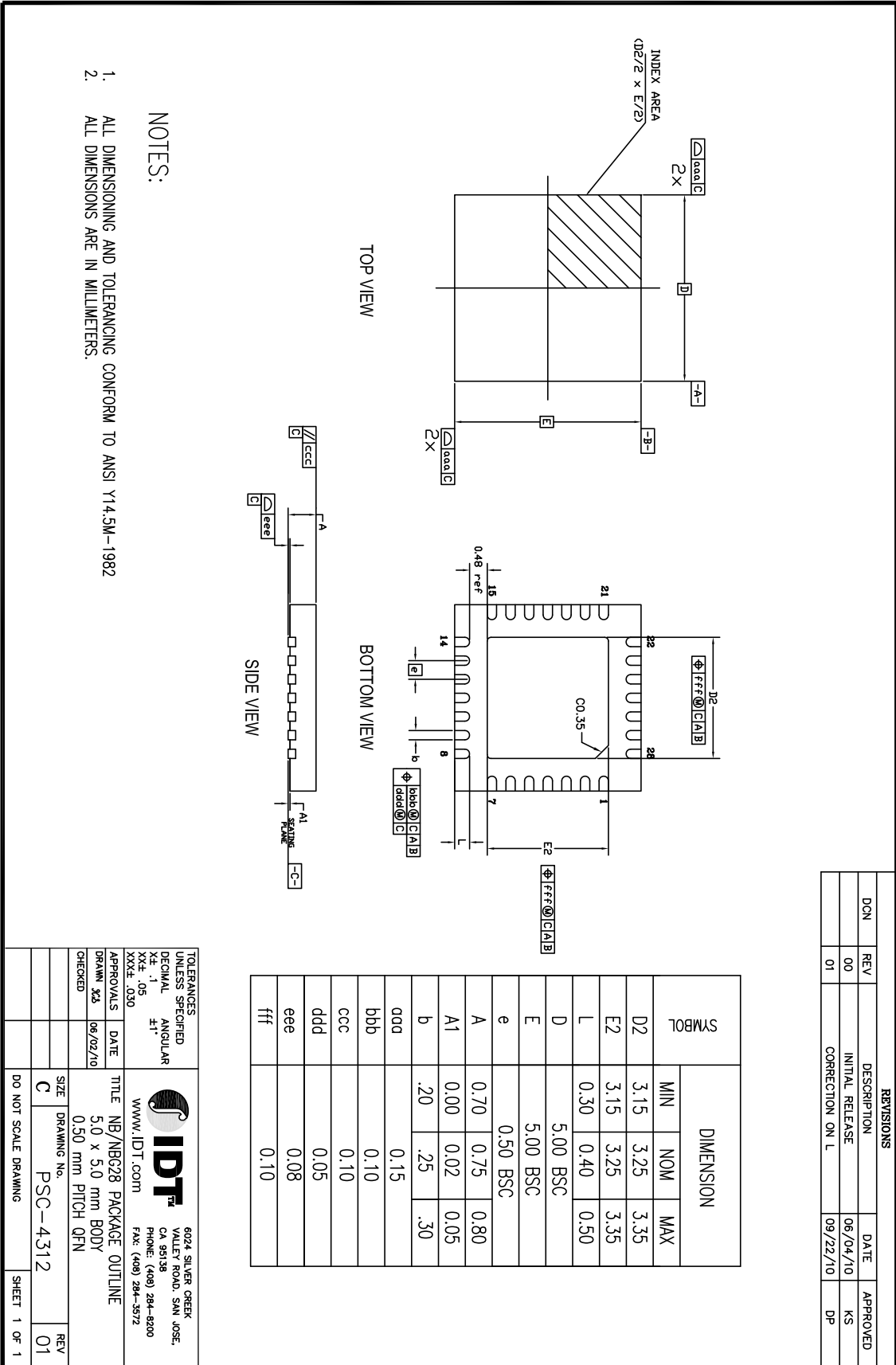

- NOTES:**
1. ALL DIMENSIONING AND TOLERANCING CONFORM TO ANSI Y14.5M-1982
 2. ALL DIMENSIONS ARE IN MILLIMETERS.

REVISIONS				
DN	REV	DESCRIPTION	DATE	APPROVED
	00	INITIAL RELEASE	06/04/10	KS
	01	CORRECTION ON L	09/22/10	DP

TOLERANCES UNLESS SPECIFIED

DECIMAL	ANGULAR
XX.X ±.05	±1°
XXX.X ±.050	

APPROVALS

DRAWN	DATE
XXX	06/02/10

CHECKED

DATE

SIZE C **DRAWING No.** PSC-4312 **REV** 01

DO NOT SCALE DRAWING SHEET 1 OF 1

IDT™ 6024 SILVER CREEK VALLEY ROAD, SAN JOSE, CA 95138 PHONE: (408) 284-8200 FAX: (408) 284-5572 www.IDT.com

TITLE NB/NBG28 PACKAGE OUTLINE
5.0 x 5.0 mm BODY
0.50 mm PITCH QFN

Ordering Information

Table 8. Ordering Information

Part/Order Number	Marking	Package	Shipping Packaging	Temperature
8SLVD1208-33NBGI	VD120833NBGI	"Lead-Free" 28 Lead VFQFN	Tray	-40°C to 85°C
8SLVD1208-33NBGI8	VD120833NBGI	"Lead-Free" 28 Lead VFQFN	Tape & Reel, pin 1 orientation: EIA-481-C	-40°C to 85°C
8SLVD1208-33NBGI/W	VD120833NBGI	"Lead-Free" 28 Lead VFQFN	Tape & Reel, pin 1 orientation: EIA-481-D	-40°C to 85°C

Table 9. Pin 1 Orientation in Tape and Reel Packaging

Part Number Suffix	Pin 1 Orientation	Illustration
8	Quadrant 1 (EIA-481-C)	
/W	Quadrant 2 (EIA-481-D)	

Revision History Sheet

Rev	Table	Page	Description of Change	Date
A		13	3.3V LVPECL Clock Input Interface application note - added figures 2D and 2E.	2/12/2014

IMPORTANT NOTICE AND DISCLAIMER

RENESAS ELECTRONICS CORPORATION AND ITS SUBSIDIARIES (“RENESAS”) PROVIDES TECHNICAL SPECIFICATIONS AND RELIABILITY DATA (INCLUDING DATASHEETS), DESIGN RESOURCES (INCLUDING REFERENCE DESIGNS), APPLICATION OR OTHER DESIGN ADVICE, WEB TOOLS, SAFETY INFORMATION, AND OTHER RESOURCES “AS IS” AND WITH ALL FAULTS, AND DISCLAIMS ALL WARRANTIES, EXPRESS OR IMPLIED, INCLUDING, WITHOUT LIMITATION, ANY IMPLIED WARRANTIES OF MERCHANTABILITY, FITNESS FOR A PARTICULAR PURPOSE, OR NON-INFRINGEMENT OF THIRD-PARTY INTELLECTUAL PROPERTY RIGHTS.

These resources are intended for developers who are designing with Renesas products. You are solely responsible for (1) selecting the appropriate products for your application, (2) designing, validating, and testing your application, and (3) ensuring your application meets applicable standards, and any other safety, security, or other requirements. These resources are subject to change without notice. Renesas grants you permission to use these resources only to develop an application that uses Renesas products. Other reproduction or use of these resources is strictly prohibited. No license is granted to any other Renesas intellectual property or to any third-party intellectual property. Renesas disclaims responsibility for, and you will fully indemnify Renesas and its representatives against, any claims, damages, costs, losses, or liabilities arising from your use of these resources. Renesas' products are provided only subject to Renesas' Terms and Conditions of Sale or other applicable terms agreed to in writing. No use of any Renesas resources expands or otherwise alters any applicable warranties or warranty disclaimers for these products.

(Disclaimer Rev.1.01 Jan 2024)

Corporate Headquarters

TOYOSU FORESIA, 3-2-24 Toyosu,
Koto-ku, Tokyo 135-0061, Japan
www.renesas.com

Trademarks



Renesas and the Renesas logo are trademarks of Renesas Electronics Corporation. All trademarks and registered trademarks are the property of their respective owners.

Contact Information

For further information on a product, technology, the most up-to-date version of a document, or your nearest sales office, please visit www.renesas.com/contact-us/.

Looking for pricing, stock, or lifecycle information?

Click below to explore more details on WIN SOURCE:

-  [View 8SLVD1208-33NBGI on WIN SOURCE](#)
-  [Renesas Electronics America](#) Information

Optimize Your Supply Chain with WIN SOURCE Solutions

-  Global Sourcing Solution
-  Obsolete Management
-  Cost Control Management
-  Shortage Management
-  Alternative Solution
-  Excess Inventory Management