



**THE DATASHEET OF
LTC3888IUHG-1#PBF**



Dual Loop 8-Phase Step-Down DC/DC Controller with Digital Power System Management

FEATURES

- ▶ PMBus/I²C Compliant Serial Interface
 - ▶ Monitor Voltage, Current, Temperature and Faults
 - ▶ Digitally Program V_{OUT}, Margins, UV, OV, Current Limit, Soft-Start/Stop and Sequencing
- ▶ Expandable to >16 Phases
- ▶ 4.5 V ≤ V_{IN} ≤ 26.5 V, 0.3 V ≤ V_{OUT} ≤ 3.45 V
- ▶ ±0.5% Output Voltage Accuracy
- ▶ Programmable PWM Loop Compensation
- ▶ Accurate PolyPhase[®] Current Sharing
- ▶ Internal EEPROM with ECC and Fault Logging
- ▶ DrMOS Output Current Monitor Interface
- ▶ DrMOS Temperature/Fault Bus Interface
- ▶ DrMOS Gate Drive Supply Monitor
- ▶ Load Step Emulation
- ▶ Internal or External PWM Clock from 250 kHz to 1 MHz
- ▶ 52-Pin (5 mm × 8 mm) QFN Package
- ▶ AEC-Q100 Qualified for Automotive Applications

APPLICATIONS

- ▶ High Current Distributed Power Systems
- ▶ Servers, Network and Storage Equipment

TYPICAL APPLICATION

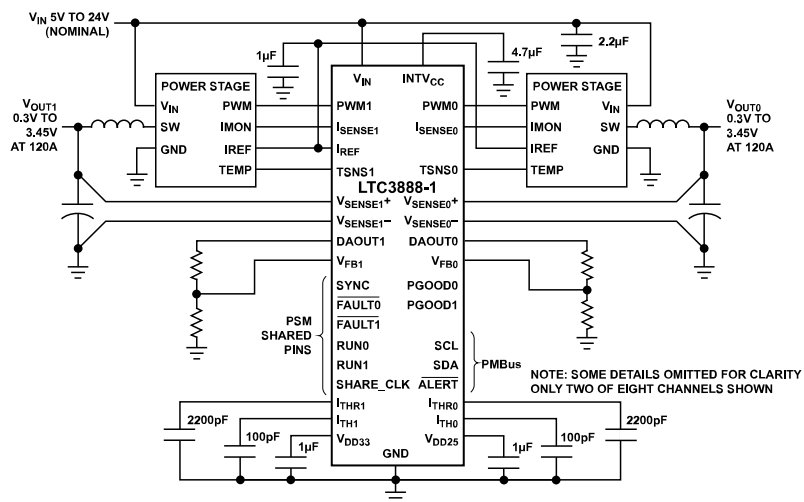

Figure 1. Dual 4-Phase PSM Rails (LTC3888-1)

GENERAL DESCRIPTION

The LTC3888/LTC3888-1/LTC3888-2¹ is a PMBus-compliant dual loop DC/DC synchronous step-down switching regulator controller with eight expandable phases supporting a wide range of master/slave configurations. The controller uses constant frequency current mode architecture to provide excellent transient response and output regulation. Each PWM master is capable of producing output voltages from 0.3 V to 3.45 V with multiple phase configurations using DrMOS devices that provide an output current monitor.

PMBus configuration and monitoring is supported by LTpower-Play™ software. Programmable loop compensation and built-in load step emulation facilitate setting bandwidth based on input voltage and output load capacitance. PMBus commands allow read back of input voltage, output voltage and current, and operating status. Operating parameters can be set via PMBus command or stored in internal EEPROM for use at power up. Switching frequency, phase configuration, output voltage (LTC3888/LTC3888-2), output current limit (LTC3888-1) and device address can also be set using external programming resistors.

Table 1.

PRODUCT	AVS, SPI ADJUST OF V _{OUT}	V _{OUT} SET BY RESISTOR DIVIDER	PMBus CONTROL OF V _{OUT}	OPTIONAL COMPENSATION ZERO
LTC3888	Yes		Yes	
LTC3888-1		Yes	Yes	Yes
LTC3888-2			Yes	Yes

¹ Protected by U.S. Patents, including 7420359, 8786265, 8786268, and 8823352. Licensed under U.S. Patent 7000125 and other related patents worldwide.

TABLE OF CONTENTS

Features.....	1	Efficiency Considerations.....	44
Applications.....	1	Power Stage Selection and Interface.....	44
General Description.....	1	Using The VDR Monitor.....	46
Typical Application.....	1	Unused TSNS Inputs.....	46
Functional Block Diagram.....	4	PWM Frequency and Inductor Selection.....	46
Specifications.....	5	C _{IN} Selection.....	47
Electrical Characteristics.....	5	C _{OUT} Selection.....	47
PMBus Timing Diagram.....	8	Programmable Loop Compensation.....	48
SPI Timing Diagram.....	9	PCB Layout Considerations.....	49
Absolute Maximum Ratings.....	10	Output Voltage Sensing.....	50
ESD Caution.....	10	Classical Analog Output Voltage Control (LTC3888-1).....	50
Pin Configuration and Function Descriptions.....	11	PMBus Output Voltage Control.....	51
Typical Performance Characteristics.....	14	Using Output Voltage Servo.....	51
Test Circuit.....	18	Soft-Start and Stop.....	52
Theory of Operation.....	19	Time-Based Output Sequencing and Ramping.....	52
Overview.....	19	Voltage-Based Output Sequencing.....	53
Major Product Features.....	19	PWM Frequency Synchronization.....	54
Main Control Loop.....	19	PolyPhase Operation and Load Sharing.....	54
Power-Up and Initialization.....	20	Resistor Configuration Pins.....	57
Analog Output Voltage Control (LTC3888-1).....	22	Internal Regulator Outputs.....	58
PMBus Output Voltage Control (LTC3888-1).....	23	IC Junction Temperature.....	59
Soft-Start.....	23	Derating EEPROM Retention at Temperature.....	59
Time-Based Output Sequencing.....	23	Configuring Open-Drain Pins.....	59
Output Ramping Control.....	23	PMBus Communication and Command Processing.....	60
Voltage-Based Output Sequencing.....	23	Status and Fault Log Management.....	61
Output Disable.....	23	LTpowerPlay—An Interactive Digital Power GUI.....	61
Output Short Cycle.....	24	Interfacing to the DC1613.....	61
Switching Frequency and Phase.....	24	Design Example.....	62
PolyPhase Load Sharing.....	24	Typical Applications.....	65
Voltage Control Loop Compensation.....	24	PMBus Command Details.....	68
Load Step Emulation.....	25	Addressing and Write Protect.....	68
Input Supply Monitoring.....	25	General Device Configuration.....	69
Output Voltage Sensing and Monitoring.....	25	On, Off and Margin Control.....	70
Output Current Sensing and Monitoring.....	25	PWM Configuration.....	71
Temperature Sense.....	25	Input Voltage and Limits.....	76
Resistor Configuration Pins.....	25	Output Voltage and Limits.....	77
Internal EEPROM With CRC.....	26	Output Current and Limits.....	79
Fault Detection.....	26	Output Timing, Delays, and Ramping.....	80
Higher-Level Fault Handling.....	28	External Temperature and Limits.....	82
Status Registers and ALERT Masking.....	28	Status Reporting.....	83
FAULT Pin I/O.....	30	Telemetry.....	88
Fault Log Operation.....	30	Fault Response and Communication.....	90
Factory Default Operation.....	32	EEPROM User Access.....	96
PMBus Serial Interface.....	33	Unit Identification.....	97
Serial Peripheral Interface (LTC3888 Only).....	37	Outline Dimensions.....	99
PMBus Command Summary.....	39		
PMBus Commands.....	39		
Data Formats.....	39		
Applications Information.....	44		

TABLE OF CONTENTS

Ordering Guide.....	100	Automotive Products.....	100
Evaluation Boards.....	100		

REVISION HISTORY**10/2023—Rev. C to Rev. D**

Changes to Ordering Guide.....	100
Changes to Evaluation Boards.....	100

4/2023—Rev. B to Rev. C

Updated Format (Universal).....	1
Changed TDA21470 to LTC7051 (Throughout).....	1
Moved Table 1.....	1
Deleted Figure 2; Renumbered Sequentially.....	1
Changes to Electrical Characteristics Section.....	5
Changes to Input High Voltage Parameter and Input Low Voltage Parameter, Table 2.....	5
Deleted Figure 8 and Figure 9.....	14
Changes to Figure 13.....	14
Changes to Design Example Section.....	62
Deleted Figure 48.....	62
Changes to Figure 82.....	63
Changes to Ordering Guide.....	100
Added Evaluation Boards Section.....	100

FUNCTIONAL BLOCK DIAGRAM

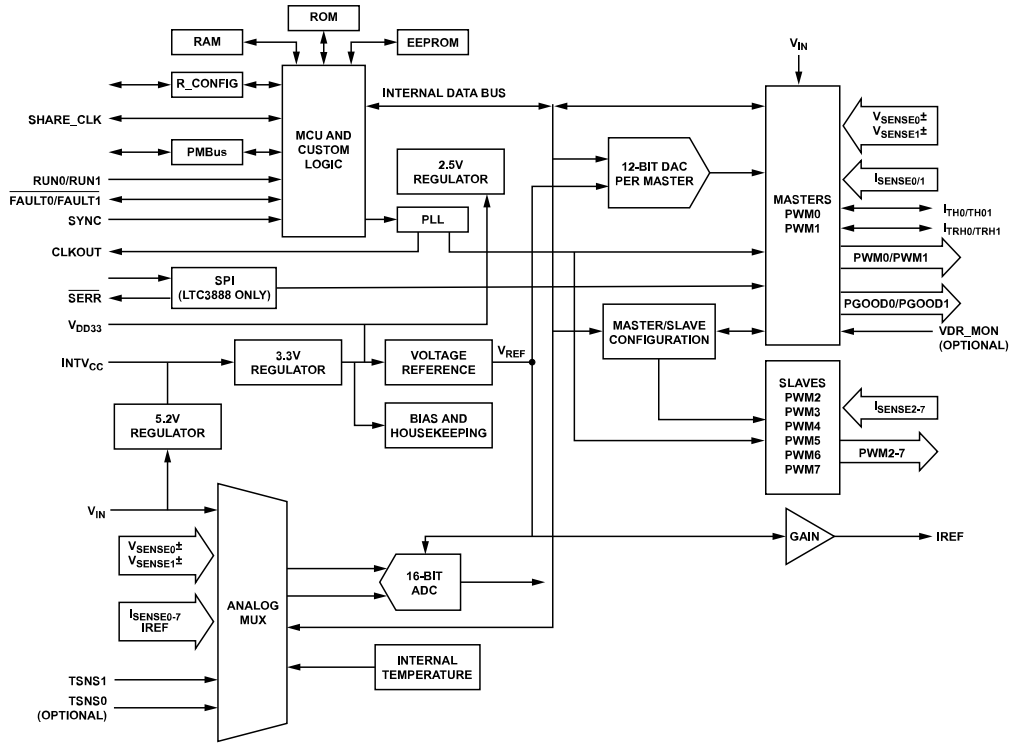

Figure 2. Functional Block Diagram

20

SPECIFICATIONS

ELECTRICAL CHARACTERISTICS

$T_J = -40^\circ\text{C}$ to $+125^\circ\text{C}$ for the minimum and maximum values, $T_A = 25^\circ\text{C}$ for the typical values, $V_{IN} = 12\text{ V}$, $V_{SENSEn+} = 1\text{ V}$, $V_{SENSEn-} = \text{GND} = 0\text{ V}$, $f_{\text{SYNC}} = 500\text{ kHz}$ (externally driven), unless otherwise specified.

Table 2.

Parameter	Symbol	Test Conditions/Comments	Min	Typ	Max	Unit
V_{IN} SUPPLY						
V_{IN} Operating Range	V_{IN}		4.5		26.5	V
IC Operating Current	I_Q	RUN0, 1 = 0 V RUN0, 1 = 3.3 V, $C_{\text{PWMn}} = 0\text{ pF}$		24 28		mA mA
INTV_{CC} LINEAR REGULATOR SUPPLY						
INTV _{CC} Output Voltage	INTV _{CC}	$V_{IN} \geq 6\text{ V}^1$		5.2		V
INTV _{CC} Input Voltage Range	EXTV _{CC}	$V_{IN} = \text{INTV}_{\text{CC}}^1$	4.5		5.5	V
PWM Undervoltage	V5 _{UVLO}	V_{DD33} Rising			4.45	V
Lockout Threshold		Hysteresis		300		mV
V_{DD33} LINEAR REGULATOR SUPPLY						
V_{DD33} Output Voltage	V_{DD33}	$\text{INTV}_{\text{CC}} \geq 4.5\text{ V}^2$	3.15	3.3	3.45	V
PMBus Undervoltage	V3 _{UVLO}	V_{DD33} Rising			3.10	V
Lockout Threshold		Hysteresis		275		mV
V_{DD25} LINEAR REGULATOR						
V_{DD25} Output Voltage ³	V_{DD25}			2.5		V
PWM CONTROL LOOPS						
Regulated Feedback Voltage	V_{FB} (LTC3888-1)	VOUT_SCALE_LOOP Not Programmed		400		mV
V_{FB} Input Current	I_{FB} (LTC3888-1)	$V_{\text{FB}} = 0.4\text{ V}$	-100		+100	nA
Accuracy without Servo ⁴	V_{OUT}	$1\text{ V} \leq V_{\text{OUT}} \leq 3.45\text{ V}$	-1.5		+1.5	%
Accuracy with Servo ^{4, 5, 6}		$0.3\text{ V} \leq V_{\text{OUT}} \leq 3.45\text{ V}$		±0.2		%
		$0.3\text{ V} \leq V_{\text{OUT}} \leq 3.45\text{ V}$	-0.5		+0.5	%
Servo Resolution				12		Bits
V_{SENSE} Input Resistance	R_{VSENSE} (LTC3888)		19.5	28		k Ω
	R_{VSENSE} (LTC3888-1/ LTC3888-2)		30	43.3		k Ω
Line Regulation	V_{LINEREG}	$6\text{ V} \leq V_{IN} \leq 24\text{ V}^4$	-0.02		+0.02	%/V
Load Regulation	V_{LOADREG}	$\Delta I_{\text{THn}} = \pm 600\text{ mV}^4$	-0.1		+0.1	%
Resolution	g_m			3		Bits
Error Amplifier $g_{m(\text{MAX})}$		$I_{\text{TH}} = 1.35\text{ V}$		5.76		mmho
Error Amplifier $g_{m(\text{MIN})}$				1		mmho
LSB Step Size				0.68		mmho
Resolution (Nonlinear) Compensation	R_{ITH}			5		Bits
Resistance $R_{\text{TH}(\text{MAX})}$ Compensation				62		k Ω
Resistance $R_{\text{TH}(\text{MIN})}$				1		k Ω
Phase-to-Phase Output Current	$I_{\text{SHARE_TOL}}$	$I_{\text{SENSEn}} - I_{\text{REF}} \geq 150\text{ mV}$	-6.5		+6.5	%
Sharing Accuracy				±3		%
I_{SENSEn} Input Current	I_{SENSE}	$1.5\text{ V} \leq I_{\text{SENSEn}} \leq 1.9\text{ V}$	-1		+3	μA
Current Monitor Reference Output Voltage	V_{IREF}	$I_{\text{IREF}} = 3\text{ mA}^7$	1.52		1.68	V
IREF Output Current	I_{IREF}	Source, $I_{\text{REF}} \geq 1.52\text{ V}$ Sink, $I_{\text{REF}} \leq 1.68\text{ V}$			-500	μA
			10			mA
SYNC Output Frequency Accuracy	f_{SYNC}		-7.5		+7.5	%
Minimum On-Time	$t_{\text{ON}(\text{MIN})}$	MFR_PWM_MODE_LTC3888-1[3] = 1 MFR_PWM_MODE_LTC3888-1[3] = 0	30		60	ns
				21		ns

SPECIFICATIONS

Table 2. (Continued)

Parameter	Symbol	Test Conditions/Comments	Min	Typ	Max	Unit
DIFFERENCE AMPLIFIERS (LTC3888-1)						
Input Offset Voltage	DA_V _{OS}	Referred to V _{SENSE+}	-16		+16	mV
Gain Error	DA_GE	Nominal Gain at DAOUT: 1.00 ⁴	-4		+4	%
Unity-Gain Crossover Frequency	DA_BW	R _L = 40 kΩ ⁸		25		MHz
Maximum Output Current	DA_I _{OUT}	Sourced, DAOUT = 3.45 V	325			μA
Maximum Output Voltage	DA_V _{MAX}			3.45		V
INPUT VOLTAGE SUPERVISOR						
Input ON/OFF Resolution LSB Step Size	N _{VON}			9		Bits
Full-Scale ON Threshold	V _{ON_FS}			54.7		mV
Input ON/OFF Threshold Accuracy	V _{ON_TOL}	V _{IN_ON} ≥ 6.5 V	-2		+2	%
OUTPUT VOLTAGE SUPERVISORS						
Accuracy ⁴	V _{UVOV_TOL}	0.5 V ≤ V _{OUT} < 1.0 V (UV and OV) 1.0 V ≤ V _{OUT} ≤ 3.6 V (UV and OV)	-3		+3	%
OUTPUT CURRENT SUPERVISORS						
I _{SENSE} Overcurrent Limit Resolution	N _{LIMIT}			7		Bits
Full-Scale Threshold	V _{OC_FS}	I _{SENSEn} - I _{REF}		500		mV
Accuracy	V _{OC_TOL}	I _{SENSEn} - I _{REF} ≥ 100 mV	-6.5		+6.5	%
GATE DRIVE VOLTAGE SUPERVISORS						
V _{DR_MON} Input Current	I _{VDR_MON}	V _{DR_MON} = 1.22 V	-1		+1	μA
UV Threshold	V _{DR_UV}		1.194		1.243	V
ADC READBACK TELEMETRY⁹						
V _{IN} Readback Resolution ¹⁰	N _{VIN}			10		Bits
V _{IN} Total Unadjusted Readback Error	V _{IN_TUE}	V _{IN} ≥ 4.5 V			1	%
V _{OUT} Resolution	N _{VOUT}			16		Bits
LSB Step Size				130		μV
V _{OUT} Total Unadjusted Readback Error	V _{OUT_TUE}	Constant Load		±0.2		%
V _{OUT} Readback Offset Voltage	V _{OUT_OS}		-0.5		+0.5	%
I _{OUT} Readback Resolution ¹⁰	N _{ISENSE}			±300		μV
I _{OUT} Total Unadjusted Readback Error	I _{SENSE_TUE}	I _{SENSEn} - I _{REF} ≥ 40 mV	-1		+1	%
I _{OUT} Readback Offset Voltage	I _{SENSE_OS}			±125		μV
Temperature Resolution ¹⁰	N _{TEMP}			10		Bits
Temperature Total Unadjusted Readback Error	T _{TUE}	0.24 V ≤ TSNS _n ≤ 1.8 V ¹¹	-1.5		+1.5	°C
Update Rate ¹²	t _{CONVERT}	MFR_PWM_CONFIG_LTC3888-1[6] = 0 MFR_PWM_CONFIG_LTC3888-1[6] = 1		90		ms
				45		ms
INTERNAL EEPROM¹³						
Number of Write Operations	Endurance	0°C ≤ T _J ≤ 85°C During All Write Operations	10,000			Cycles
Stored Data Retention	Retention	T _J ≤ 125°C	10			Years
STORE_USER_ALL Execution Duration	Mass Write Time	0°C ≤ T _J ≤ 85°C During All Write Operations		0.2	2	s
DIGITAL INPUTS (SCL, SDA, RUN_n, FAULT_n, SYNC, SHARE_CLOCK)						
Input High Voltage	V _{IH}	SCL, SDA, RUN _n , FAULT _n LTC3888 SCL, SDA, RUN _n , FAULT _n LTC3888-1 SYNC, SHARE_CLK	1.25			V
			2			V
			1.8			V

SPECIFICATIONS

Table 2. (Continued)

Parameter	Symbol	Test Conditions/Comments	Min	Typ	Max	Unit
Input Low Voltage	V_{IL}	SCL, SDA, RUN $_n$, \overline{FAULT}_n LTC3888 SCL, SDA, RUN $_n$, \overline{FAULT}_n LTC3888-1			0.8 1.4	V V
Input Hysteresis	V_{HYST}	SYNC, SHARE_CLK SCL, SDA ⁴		65	0.6	mV V
Input Leakage Current	I_{IN}	0 V \leq SCL, SDA, RUN0, RUN1 \leq 5.5 V	-5		+5	μ A
Input Capacitance ⁸	C_{IN}				10	pF
Input Digital Filter Delay	t_{FILT}	\overline{FAULT}_n RUN $_n$		3 10		μ s μ s
DIGITAL OUTPUTS (SCL, SDA, RUN $_n$, \overline{FAULT}_n , SYNC, SHARE_CLOCK, ALERT, PWM $_n$, PGOOD $_n$, CLKOUT)						
Output Low Voltage	V_{OL}	$I_{SINK} = 3$ mA: SDA, SCL, \overline{FAULT}_n , ALERT, SYNC, RUN $_n$, SHARE_CLK $I_{SINK} = 2$ mA: PWM $_n$, PGOOD $_n$, CLKOUT			400 300	mV mV
Output High Voltage	V_{OH}	PWM $_n$, $I_{SOURCE} = 2$ mA	2.7			V
Output Leakage Current	I_{LKG}	0 V \leq PWM $_n$, PGOOD $_n \leq V_{DD33}$, 0 V \leq CLKOUT $\leq V_{DD33}$ 0 V $\leq \overline{FAULT}_n$, SYNC ≤ 3.6 V, 0 V \leq SHARE_CLOCK ≤ 3.6 V 0 V \leq RUN $_n$, SCL, SDA, ALERT ≤ 5.5 V	-2 -2 -2 -5 -5		+2 +2 +2 +5 +5	μ A μ A μ A μ A μ A
PWM $_n$ Output Rise Time	t_{RO}	$C_{LOAD} = 30$ pF, 10% to 90%		5		ns
PWM $_n$ Output Fall Time	t_{FO}	$C_{LOAD} = 30$ pF, 90% to 10%		4		ns
PMBus TIMING						
Serial Bus Operating Frequency	f_{SMB}		10		400	kHz
Bus Free Time Between Stop and Start	t_{BUF}		1.3			μ s
Hold Time After (Repeated) Start Condition. After this Period, the First Clock is Generated.	$t_{HD,STA}$		0.6			μ s
Repeated Start Condition Setup Time	$t_{SU,STA}$		0.6			μ s
Stop Condition Setup Time	$t_{SU,STO}$		0.6			μ s
Data Hold Time:	$t_{HD,DAT}$					
Receiving Data			0			ns
Transmitting Data			0.3		0.9	μ s
Input Data Setup Time	$t_{SU,DAT}$		100			ns
Clock Low Time-Out	$t_{TIMEOUT}$		25		35	ms
Serial Clock Low Period	t_{LOW}		1.3		10,000	μ s
Serial Clock High Period	t_{HIGH}		0.6			μ s
Clock or Data Fall Time	t_F	90% to 10%	20		300	ns
Clock or Data Rise Time	t_R	10% to 90%	20		300	ns
SERIAL PERIPHERAL INTERFACE						
SCK Clock Frequency	f_{SCK}				20	MHz
SCK Clock High Time	t_{HI}		20			ns
SCK Clock Low Time	t_{LO}		20			ns
SDI Setup Time	t_{SU}		10			ns
SDI Hold Time	t_{HD}		10			ns
\overline{SCS} Setup Time	t_{SUCS}		15			ns
\overline{SCS} Hold Time	t_{HDCS}		15			ns
Continuous SPI Byte Data Rate ⁸	t_{RATE}				250	kHz
Input High Voltage	V_{IH}	SDI, SCK, \overline{SCS} MFR_PWM_CONFIG_LTC3888[5] = 0 MFR_PWM_CONFIG_LTC3888[5] = 1	2.1 1.25			V V

SPECIFICATIONS

Table 2. (Continued)

Parameter	Symbol	Test Conditions/Comments	Min	Typ	Max	Unit
Input Low Voltage	V_{IL}	SDI, SCK, \overline{SCS} MFR_PWM_CONFIG_LTC3888[5] = 0			0.8	V
		MFR_PWM_CONFIG_LTC3888[5] = 1			0.54	V
Input Hysteresis	V_{HYST}	SDI, SCK, \overline{SCS} MFR_PWM_CONFIG_LTC3888[5] = 0		65		mV
		MFR_PWM_CONFIG_LTC3888[5] = 1		65		mV
Input Leakage Current	I_{IN}	$0\text{ V} \leq \text{SDI, SCK, } \overline{\text{SCS}} \leq V_{DD33}$	-5		+5	μA
Output Low Voltage	V_{OL}	$\overline{\text{SERR}}$, $I_{\text{SINK}} = 2\text{ mA}$		0.2	0.4	V
Output Leakage Current	I_{LKG}	$0\text{ V} \leq \overline{\text{SERR}} \leq V_{DD33}$	-1		+1	μA

- Do not apply a voltage source to INTV_{CC} unless shorted to V_{IN} . Otherwise, connect only external passive components for LTC3888/LTC3888-1/LTC3888-2 configuration. See [Electrical Characteristics](#) section for applicable limits beyond which permanent damage may occur.
- An external voltage source may be connected directly to V_{DD33} only if the device is not powered from V_{IN} or INTV_{CC} . Otherwise, connect only external passive components for LTC3888/LTC3888-1/LTC3888-2 configuration. See [Electrical Characteristics](#) section for applicable limits beyond which permanent damage may occur.
- Do not apply a voltage or current source directly to these pins. Connect only external passive components for LTC3888/LTC3888-1/LTC3888-2 configuration and application, otherwise permanent damage may occur.
- LTC3888/LTC3888-1/LTC3888-2 output voltage control is trimmed and measured in a feedback loop that servos I_{TH} to a specified value. In the LTC3888-1 output accuracy may be better than that of other loop regulated voltages (DAOOUT, VFB). Output accuracy without Servo Mode may degrade when external gain deviates from 3.5 in the application.
- Specified accuracy requires Servo Mode to be set with MFR_PWM_MODE_LTC3888 command bit 6. $V_{OUT_COMMAND}$ must be within $\pm 5.5\%$ of unadjusted V_{OUT} .
- See [Test Circuit](#) section.
- Do not apply a voltage source directly to these pins. See [Electrical Characteristics](#) section for applicable limits beyond which permanent damage may occur.
- Guaranteed by design.
- ADC tested with PWMs disabled. Comparable capability demonstrated by in-circuit evaluations. Total unadjusted error includes all gain and linearity errors, as well as offsets.
- Internal 32-bit calculations using 16-bit ADC results are limited to 10-bit mantissa resolution by PMBus linear 11-bit data format.
- Limits guaranteed by TSNS voltage and current measurements during test, including ADC read backs.
- Data conversion is done in round robin fashion. If all inputs signals are scanned, continuous in-sequence conversions result in a typical latency of 90ms.
- The EEPROM endurance, retention and mass write times are guaranteed by design, characterization and correlation with statistical process controls. Minimum retention applies only for devices cycled less than the minimum endurance specification. EEPROM read commands (e.g., RESTORE_USER_ALL) are valid over the entire specified operating junction temperature range.

PMBUS TIMING DIAGRAM

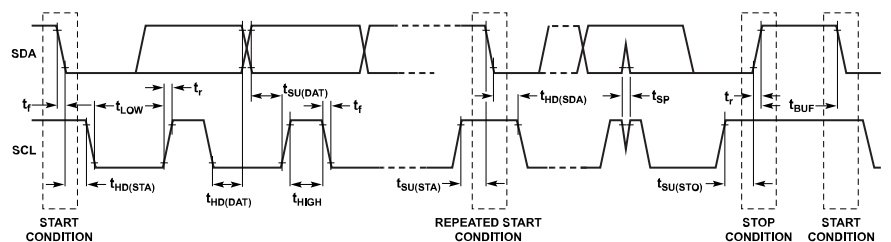

Figure 3. PMBus Timing Diagram

SPECIFICATIONS

SPI TIMING DIAGRAM

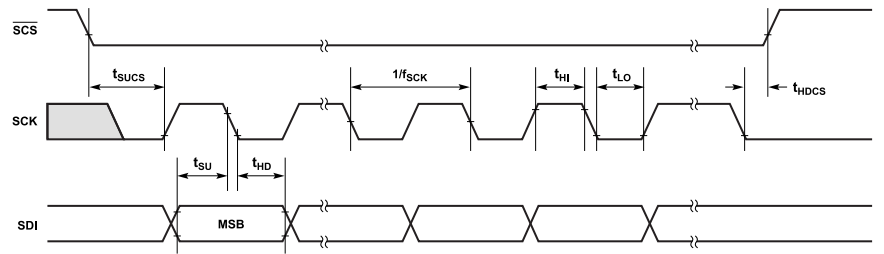

Figure 4. LTC3888 SPI Timing Diagram

ABSOLUTE MAXIMUM RATINGS

Table 3.

Parameter	Rating
V_{IN} Supply Voltage	-0.3 V to +40 V
V_{SENSEn}^+ , DAOUT n (LTC3888-1/LTC3888-2)	-0.3 V to +4.2 V
V_{SENSEn}^-	-0.3 V to +0.3 V
I_{SENSEn} , V_{FBn} (LTC3888-1), C_{ZEROn} (LTC3888-2)	-0.3 V to +3.6 V
TSNS n , VDR_MON	-0.3 V to +6.0 V
SYNC, \overline{FAULTn} , PGOOD n , CLKOUT, SHARE_CLK	-0.3 V to +3.6 V
SDI, SCK, \overline{SCS} , \overline{SERR} (LTC3888)	-0.3 V to +3.6 V
SCL, SDA, RUN n	-0.3 V to +5.5 V
INTV $_{CC}^1$	
V_{DD33}^2	
IREF, PWM n^3	
V_{DD25} , I_{THn} , I_{THRn} , R_{SET} , ASEL n , ILIM n _CFG, PWM_CFG 4	
Operating Junction Temperature Range 5,6	-40°C to +125°C 7
Storage Temperature Range	-65°C to +150°C 7
ABSMAX T $_j$	125°C 7

¹ Do not apply a voltage source to INTV $_{CC}$ unless shorted to V_{IN} . Otherwise, connect only external passive components for LTC3888/LTC3888-1/LTC3888-2 configuration. See [Electrical Characteristics](#) section for applicable limits beyond which permanent damage may occur.

² An external voltage source may be connected directly to V_{DD33} only if the device is not powered from V_{IN} or INTV $_{CC}$. Otherwise, connect only external passive components for LTC3888/LTC3888-1/LTC3888-2 configuration. See [Electrical Characteristics](#) section for applicable limits beyond which permanent damage may occur.

³ Do not apply a voltage source directly to these pins. See [Electrical Characteristics](#) section for applicable limits beyond which permanent damage may occur.

⁴ Do not apply a voltage or current source directly to these pins. Connect only external passive components for LTC3888/LTC3888-1/LTC3888-2 configuration and application, otherwise permanent damage may occur.

- ⁵ The LTC3888/LTC3888-1/LTC3888-2 is specified over the -40°C to +125°C operating junction temperature range. High junction temperatures degrade operating lifetimes; operating lifetime is derated for junction temperatures greater than 125°C. Note the maximum ambient temperature consistent with these specifications is determined by specific operating conditions in conjunction with board layout, the rated package thermal impedance and other environmental factors.
- ⁶ This IC includes overtemperature protection that is intended to protect the device during momentary overload conditions. The maximum rated junction temperature will be exceeded when this protection is active. Continuous operation above the specified absolute maximum operating junction temperature may impair device reliability or permanently damage the device.
- ⁷ See [Derating EEPROM Retention at Temperature](#) section for junction temperatures in excess of 125°C.

Stresses at or above those listed under Absolute Maximum Ratings may cause permanent damage to the product. This is a stress rating only; functional operation of the product at these or any other conditions above those indicated in the operational section of this specification is not implied. Operation beyond the maximum operating conditions for extended periods may affect product reliability.

ESD CAUTION



ESD (electrostatic discharge) sensitive device. Charged devices and circuit boards can discharge without detection. Although this product features patented or proprietary protection circuitry, damage may occur on devices subjected to high energy ESD. Therefore, proper ESD precautions should be taken to avoid performance degradation or loss of functionality.

PIN CONFIGURATION AND FUNCTION DESCRIPTIONS

Table 4. Pin Function Descriptions (Continued)

Pin No.	Mnemonic	Description
9, 38	I _{TH0} , I _{TH1}	PWM Current Control Threshold and Loop Compensation Nodes. Peak current increases with I _{TH} voltage. Attach a low ESR capacitor between these pins and GND for adequate loop compensation. Refer to the Applications Information section for more details.
10, 37	I _{THRO} , I _{THR1}	Loop Compensation Nodes. Attach a low ESR capacitor between these pins and GND for adequate loop compensation. Refer to the Applications Information section for more details.
11, 36	DAOUT0, DAOUT1 (LTC3888-1/ LTC3888-2)	Differential Amplifier Outputs. DAOUT0/1 provide a voltage equal to the difference between V _{SENSE+} and V _{SENSE-} for that channel, referenced to GND (paddle). The LTC3888-1 requires a resistor divider on this pin.
12, 35	V _{FB0} , V _{FB1} (LTC3888-1), CZERO0, CZERO1 (LTC3888-2)	Error Amplifier Inverting Input. The PWM control loop regulates this voltage when the output rail is on. The LTC3888-1 requires a resistor divider on this pin.
11, 36 (LTC3888), 13, 34 (LTC3888-1/ LTC3888-2)	PGOOD0, PGOOD1	Power Good Indicator Open-Drain Outputs. These outputs are driven low through an 80 μs filter when the respective channel output is below its programmed UV fault limit or above its programmed OV fault limit. If used, a pull-up resistor is required in the application.
11 (LTC3888), 13 (LTC3888-1/LTC3888-2)	CLKOUT	Expansion Clock Output. This output provides a phase expansion clock to a second LTC3888/LTC3888-1/LTC3888-2 if bit 3 of MFR_PWM_CONFIG_LTC3888 is set. If used, a pull-up resistor is required. Minimize the capacitance on this line to ensure its time constant is fast enough for the application.
14	SYNC	External Clock Synchronization Input and Open-Drain Output. If desired, an external clock can be applied to this pin to synchronize the internal PWM channels. Otherwise this pin can pull to ground at the selected PWM switching frequency with a 500 ns pulse width. A pull-up resistor to 3.3 V is required if SYNC is provided by the LTC3888/LTC3888-1/LTC3888-2. Minimize the capacitance on this line to ensure its time constant is fast enough for the application.
15	SCL	Serial PMBus Clock Input and Open-Drain Output. SCL functions as an output only if clock stretching is enabled. A pull-up resistor to the bus supply is required in the application.
16	SDA	Serial PMBus Data Input and Open-Drain Output. A pull-up resistor to the bus supply is required in the application.
17	$\overline{\text{ALERT}}$	Open-Drain Status Output. This pin may be connected to the system SMBALERT# wire-AND interrupt signal. A pull-up resistor to the bus supply is required in the application. This pin should be left open if not used.
18, 19	$\overline{\text{FAULT0}}$, FAULT1	Programmable Digital Inputs and Open-Drain Outputs for Fault Sharing. These pins are used for channel-to-channel fault communication and propagation. A pull-up resistor to 3.3 V is required in the application.
20, 21	RUN0, RUN1	Run Control Inputs and Open-Drain Outputs. A voltage above 1.5 V (LTC3888/LTC3888-2) and 2 V (LTC3888-1) is required on these pins to enable the respective PWM master channel. The LTC3888/LTC3888-1/LTC3888-2 may drive these pins low under certain reset/restart conditions regardless of any PMBus command settings. A pullup resistor is required in the application.
22	R _{SET}	Resistor Configuration Set Input. Connect a 1% 18.7 kΩ resistor between this pin and GND to set the selection values for the configuration resistors for programming bus address, output current limit and other PWM settings. Refer to the Applications Information section for more details.
23, 24	ASEL0/ASEL1	PMBus Serial Address Select Inputs. Connect optional 1% resistors between these pins and GND to select the serial bus interface address. Refer to the Applications Information section for more detail.
25, 26	VOUT0_CFG, VOUT1_CFG (LTC3888/ LTC3888-2), ILIM0_CFG, ILIM1_CFG (LTC3888-1)	Output Voltage (LTC3888/LTC3888-2), Output Current Limit (LTC3888-1) Configuration Inputs. Connect optional 1% resistors between these pins and GND to select the output current limit for each channel. Refer to the Applications Information section for more detail.

PIN CONFIGURATION AND FUNCTION DESCRIPTIONS

Table 4. Pin Function Descriptions (Continued)

Pin No.	Mnemonic	Description
27	PWM_CFG	PWM Configuration Input. Connect an optional 1% resistor between this pin and GND to configure PWM switching frequency and master/slave configuration. Refer to the Applications Information section for more detail.
28	V _{DD25}	Internal 2.5 V Regulator Output. Bypass this pin to GND with a low ESR 1 μ F capacitor. Do not load this pin with external current.
12 (LTC3888)	SDI	Serial Data Input. This pin provides input data for the Serial Peripheral Interface (SPI). Ground this pin if not used.
13 (LTC3888)	SCK	Serial Clock Input. This pin provides the input data clock for the SPI. Ground this pin if not used.
34 (LTC3888)	$\overline{\text{SERR}}$	Open-Drain SPI Status Output. This pin is pulled low if a SPI transmission error is detected. Do not wire this pin to a standard (shared) SPI SDO line. Refer to the Theory of Operation section for more detail. A pull-up resistor is required in the application. This pin should be left open if not used.
35 (LTC3888)	$\overline{\text{SCS}}$	SPI Chip Select Input. This active-low input is used to enable the LTC3888 to receive a SPI data transmission. Wire this pin to V _{DD33} if not used.
29	SHARE_CLK	Share Clock Input and Open-Drain Output. Share clock, nominally 100 kHz, is used to sequence multiple rails in a power system utilizing more than one ADI PMBus controller. A pull-up resistor to 3.3 V is required in the application. Minimize the capacitance on this line to ensure the time constant is fast enough for the application.
30	V _{DD33}	Internal 3.3 V Regulator Output. Bypass this pin to GND with a low ESR capacitor (1 μ F to 2.2 μ F). The LTC3888/LTC3888-1/LTC3888-2 may also be powered from an external 3.3 V source attached to this pin for programming purposes only, if the device is otherwise unpowered. Connect only external passive components for LTC3888/LTC3888-1/LTC3888-2 configuration and application.
31	INTV _{CC}	5.2 V Regulator Output. Bypass this pin to GND with a low ESR 4.7 μ F capacitor. Connect only external passive components for LTC3888/LTC3888-1/LTC3888-2 configuration and application.
32	V _{IN}	Main Input Supply. Decouple this pin to GND with a low ESR capacitor (0.1 μ F to 2.2 μ F). In applications where V _{IN} will always operate below 6 V, short this pin and INTV _{CC} together.
33	IREF	DrMOS Current Sense Reference. This voltage output provides reference bias for floating current monitors from DrMOS devices. Decouple this pin to GND (exposed pad) at the LTC3888/LTC3888-1/LTC3888-2 and each power stage with 100 nF to 1 μ F using low ESR capacitors.
53	EPAD (GND)	Ground. All small-signal and compensation components should connect to this pad. The exposed pad must be soldered to a suitable PCB copper ground plane for proper electrical operation and to obtain the specified package thermal resistance.

TYPICAL PERFORMANCE CHARACTERISTICS

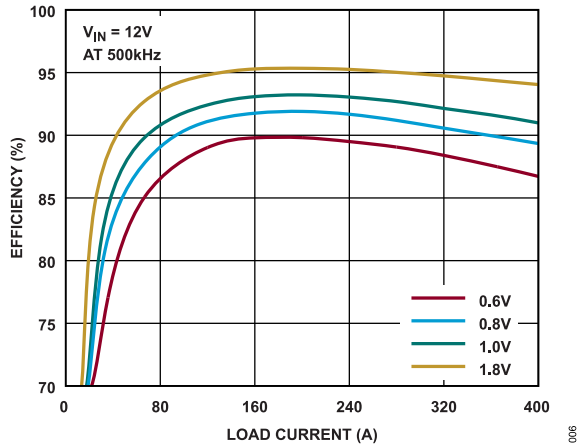

Figure 8. Efficiency vs. Load Current (8-Phase Using LTC7051)

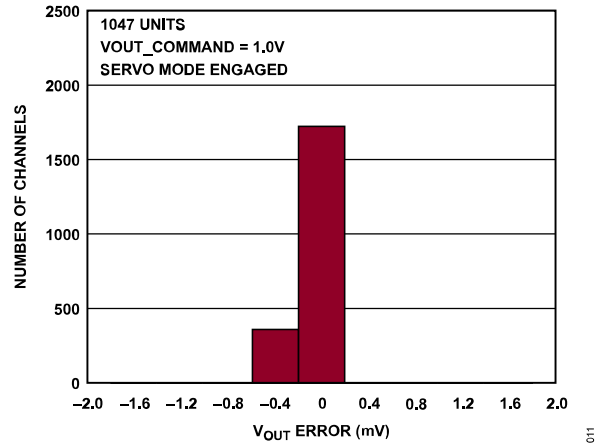

Figure 11. Typical Output Voltage Distribution at 25°C with Servo

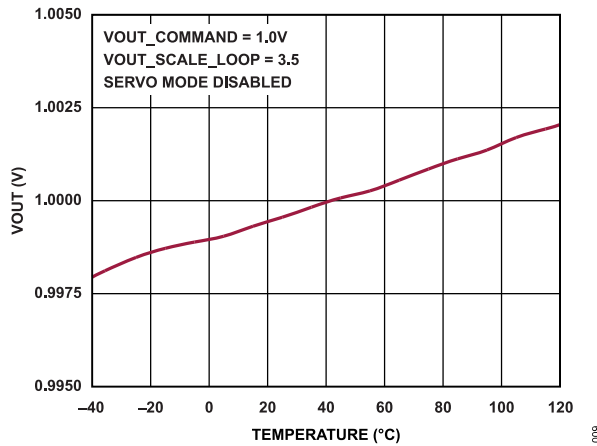

Figure 9. Regulated Output vs. Temperature

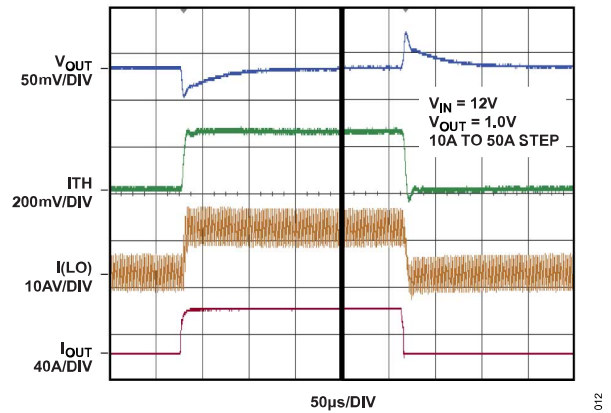

Figure 12. 4-Phase Load Step Response (Using LTC7051)

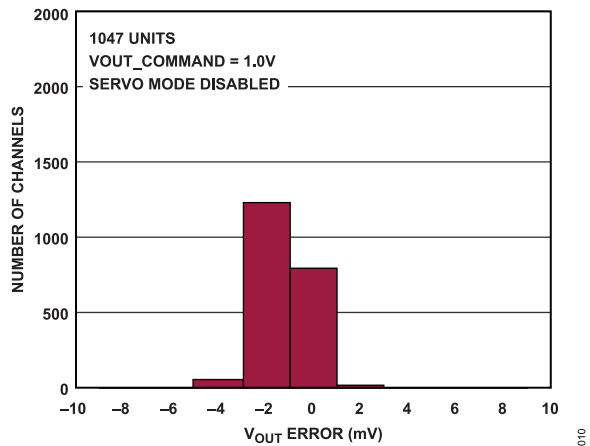

Figure 10. Typical Output Voltage Distribution at 25°C Without Servo

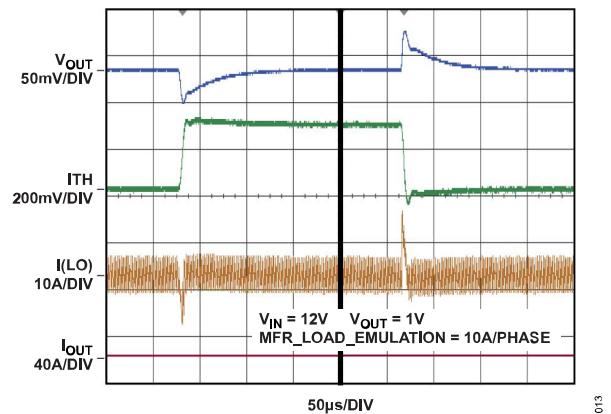

Figure 13. Emulated 4-Phase Load Step Response (Using LTC7051)

TYPICAL PERFORMANCE CHARACTERISTICS

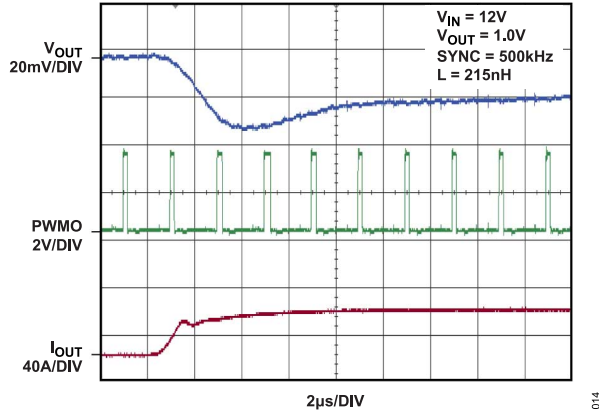

Figure 14. 4-Phase Single Cycle Response (Using LTC7051 with $C_{OUT} = 4\text{ mF}$)

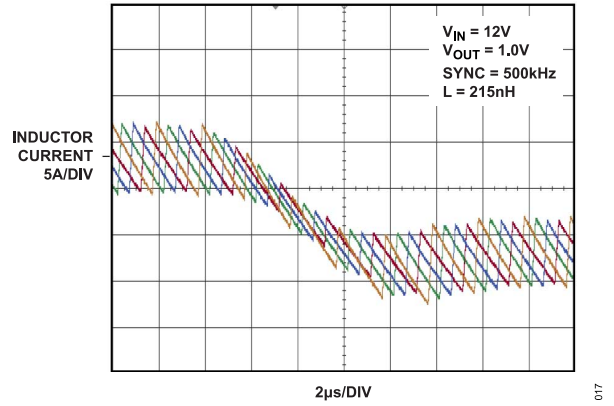

Figure 17. 4-Phase Dynamic Load Sharing

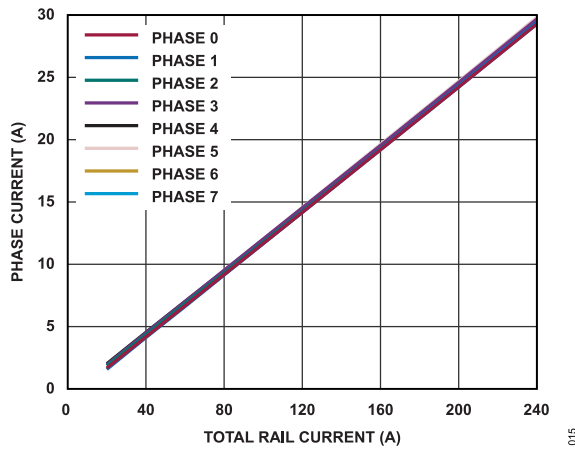

Figure 15. 8-Phase DC Output Current Sharing (Using LTC7051)

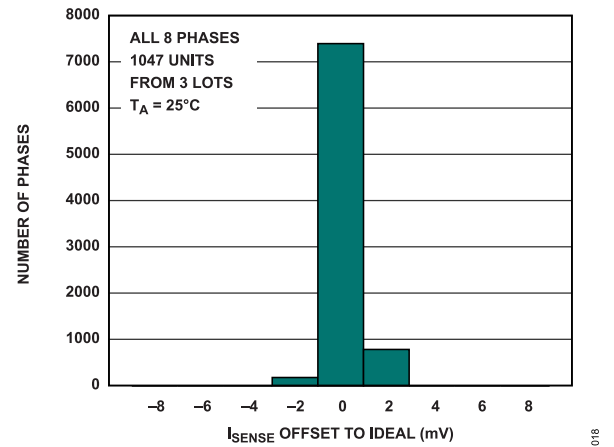

Figure 18. Typical Distribution of Slave I_{OUT} Offset (Not Including DrMOS Mismatch) Room

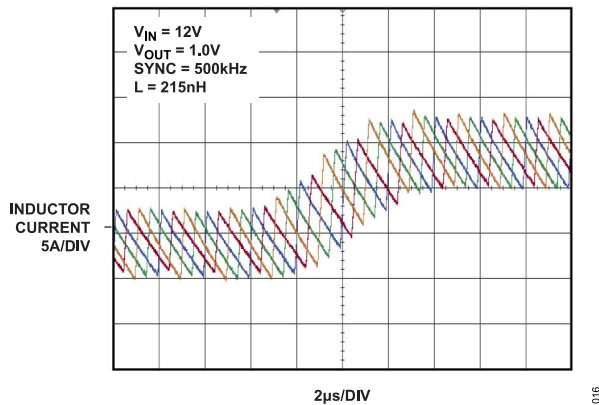

Figure 16. 4-Phase Dynamic Load Sharing

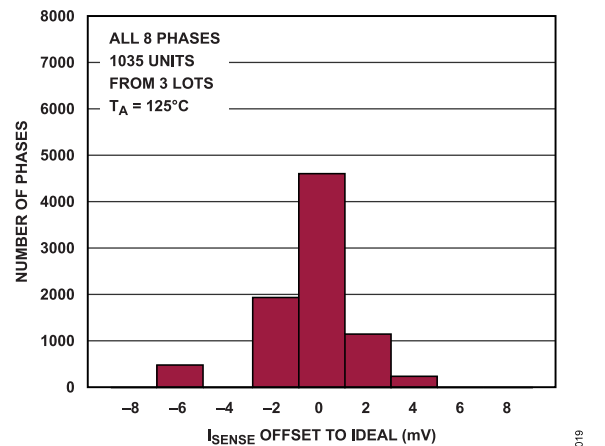

Figure 19. Typical Distribution of Slave I_{OUT} Offset (Not Including DrMOS Mismatch) Hot

TYPICAL PERFORMANCE CHARACTERISTICS

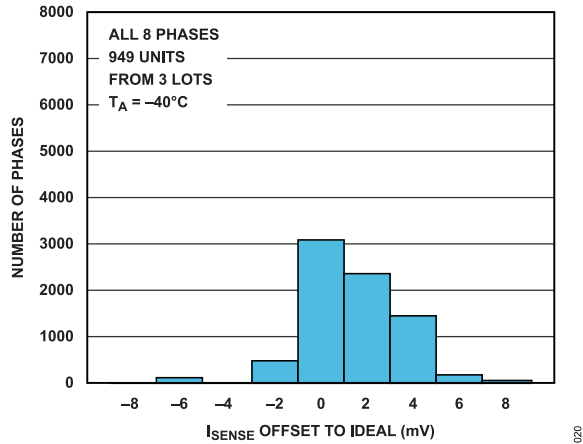

Figure 20. Typical Distribution of Slave I_{OUT} Offset (Not Including DrMOS Mismatch) Cold

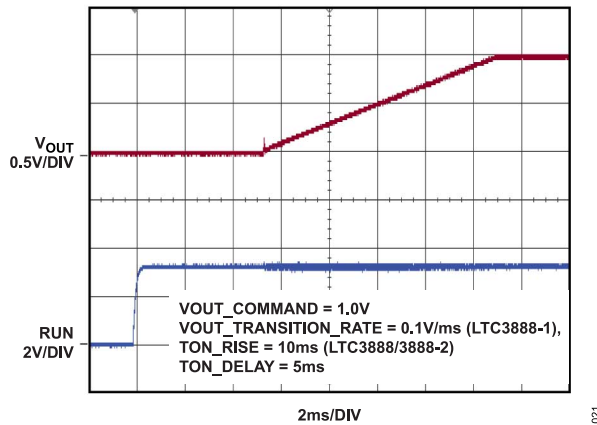

Figure 21. Soft-Start Ramp

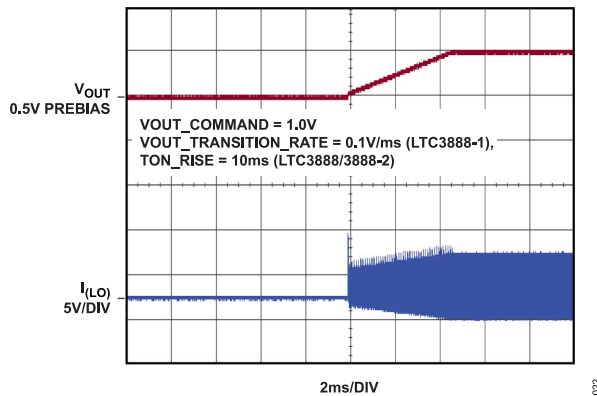

Figure 22. Start-Up into a Prebiased Load

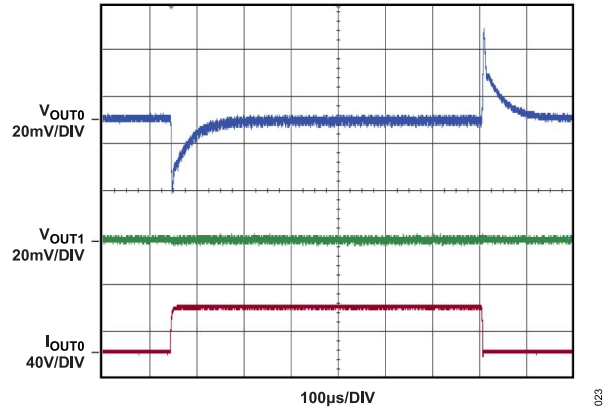

Figure 23. 4+4 Channel Crosstalk (Using LTC7051)

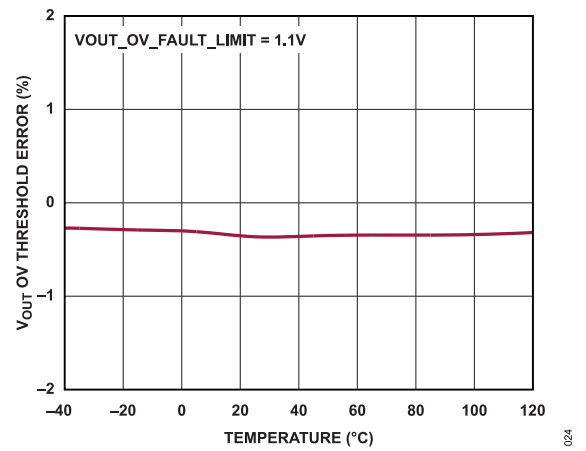

Figure 24. Output Overvoltage Threshold Error vs. Temperature

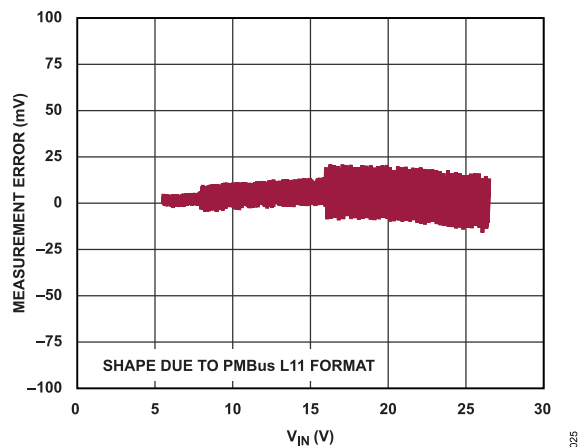

Figure 25. V_{IN} ADC TUE

TYPICAL PERFORMANCE CHARACTERISTICS

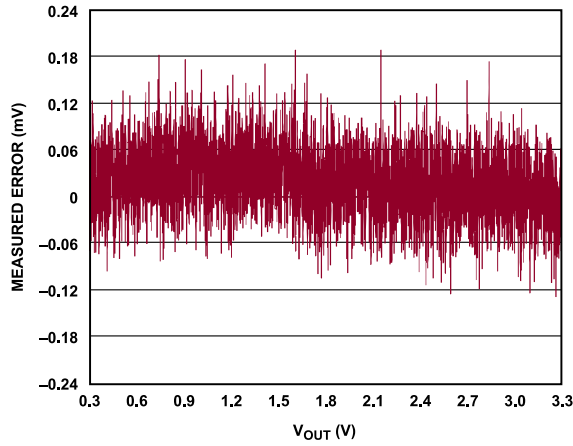

Figure 26. V_{OUT} ADC TUE

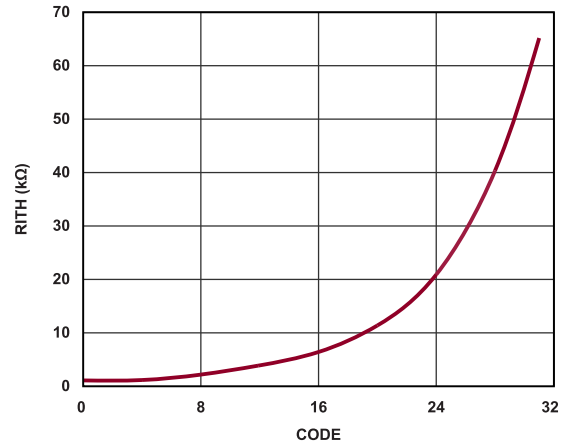

Figure 29. Programmable R_{ITH}

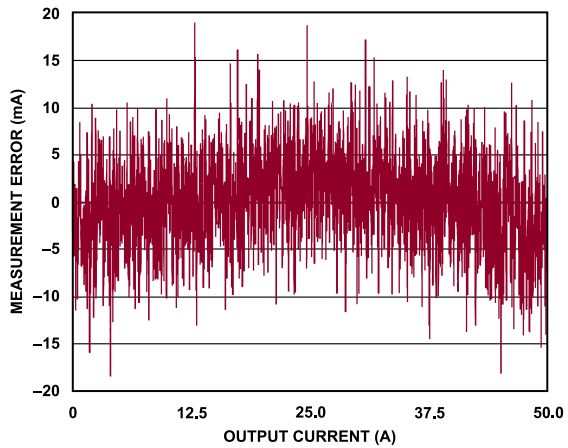

Figure 27. I_{OUT} ADC TUE

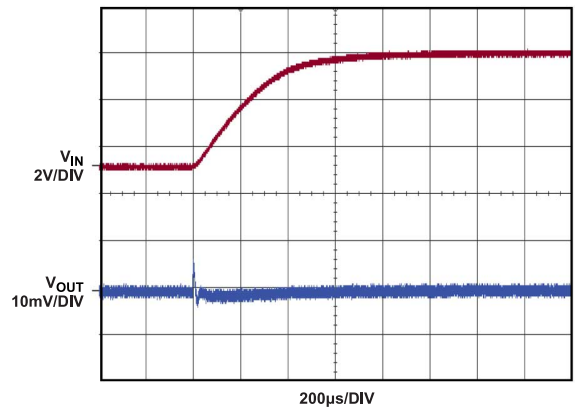

Figure 30. 4-Phase Line Step Transient (Using *LTC7051*)

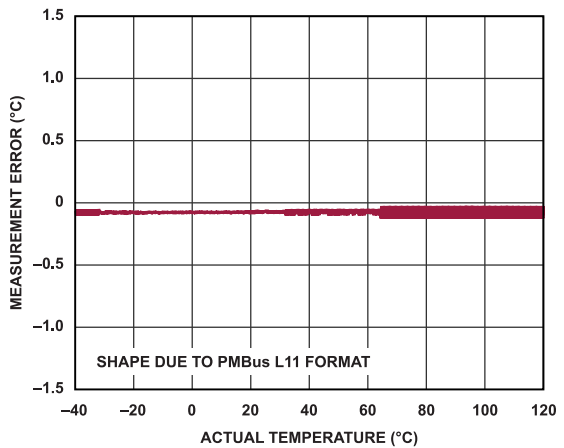

Figure 28. Temperature ADC TUE (Not Including $DrMOS$ Error)

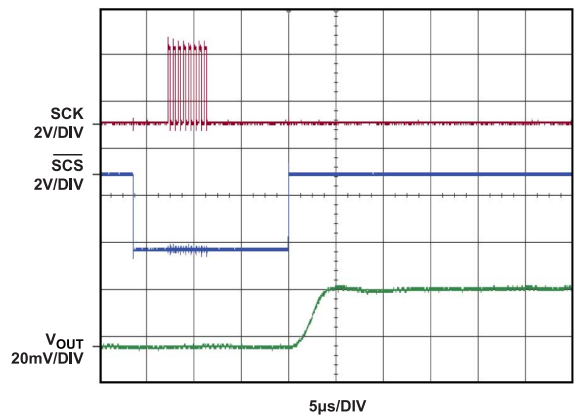

Figure 31. SPI Command 25 mV V_{OUT} Adjustment

TYPICAL PERFORMANCE CHARACTERISTICS

TEST CIRCUIT

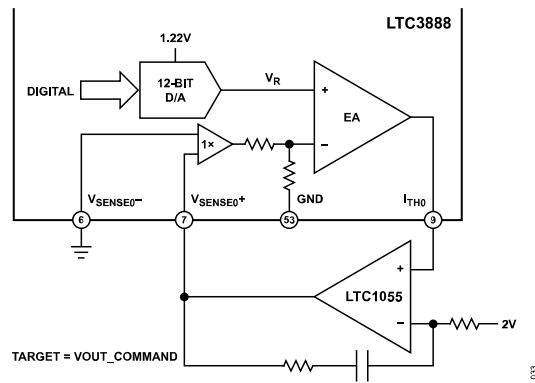

Figure 32. LTC3888/LTC3888-2

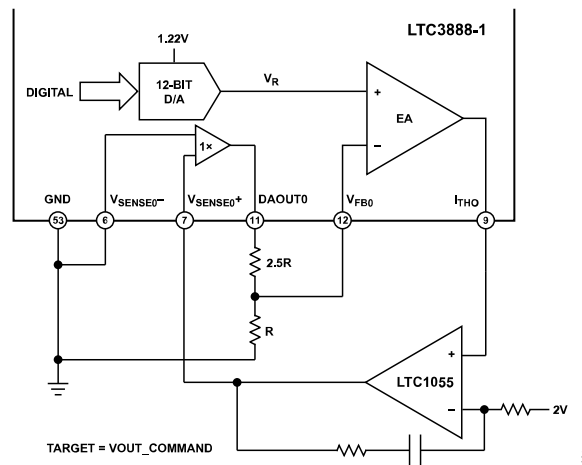

Figure 33. LTC3888-1

THEORY OF OPERATION

OVERVIEW

The LTC3888/LTC3888-1/LTC3888-2 is a constant frequency analog current mode controller for DC/DC step-down switch-mode applications. It provides up to two independent voltage loops (masters) and also contains six additional slave modulators, affording a wide range of predetermined PolyPhase configurations.

The device is designed to be used with external power stages that provide an output current monitor, either as a voltage or current. This includes higher level integrations such as non-isolated power blocks. The LTC3888/LTC3888-1/LTC3888-2 provides a direct interface to the shared temperature and fault indication bus commonly found on such power stages, as well as an optional DrMOS gate drive supply voltage supervisor.

The chip operates from a V_{IN} power supply between 4.5 V and 28.5 V. Without any other programming the LTC3888-1 output voltage may be set to any value between 0.4 V and 3.45 V using an external resistor divider and the factory EEPROM settings. The LTC3888/LTC3888-2 output voltage can be set either with resistor configuration pins (see [Table 14](#)) or EEPROM.

The LTC3888/LTC3888-1/LTC3888-2 also features a PMBus compliant digital interface for monitoring and setting of important power system parameters, including direct output control using the external resistor divider, if desired.

About This Document

PMBus command pages 0 and 1 control the two voltage regulation loops associated with PWM0 and PWM1, respectively. In this document, these may also be referred to as masters or master channels. There are often unique IC pins associated with each of these master channels, such as I_{TH0} and I_{TH1} . In cases where discussion applies to both or either of the master channels, these pin names may appear without index. Statements herein related to the LTC3888 also apply to the LTC3888-1 and LTC3888-2, unless specifically noted.

PWM2 to PWM7 are not directly controlled by PMBus operation, but instead are managed by the master channel that is assigned to control them. In this document, the modulators associated with PWM2 to PWM7 will be referred to as slaves or slave channels. Occasionally, the term PWM or channel may apply to any of the eight PWM modulators. Rail will designate a master channel and the group of slaves it controls to produce a single output voltage, including multiple master channels with wire-OR I_{TH} control.

The phrase operating memory or simply RAM refers to volatile onboard RAM holding PMBus commands during operation.

PMBus commands in this document are given in all capital letters with no white space, although hyphens or underscores may be included. For brevity, the indentifying phrase PMBus command is most often omitted when this typeface appears. All PMBus commands from 0x00 through 0xFF not listed in [Table 11](#) section are implicitly not supported by the LTC3888. Writing to any command

not listed in this table may result in a CML fault and/or undesired operation of the part.

MAJOR PRODUCT FEATURES

- ▶ Analog and/or Digitally Programmable Output Voltage with UV/OV Supervisors
- ▶ Digitally Programmable Output Current Limit
- ▶ Digitally Programmable Input Voltage Supervisor
- ▶ Digitally Programmable Switching Frequency
- ▶ Digitally Programmable On and Off Delay Times
- ▶ Digitally Programmable Soft-Start/Stop
- ▶ Digitally Programmable Load Step Emulation
- ▶ Operating Condition Telemetry
- ▶ Phase-Locked Loop for Synchronous PolyPhase Operation
- ▶ Non-Volatile Configuration Memory
- ▶ Optional External Configuration Resistors for Key Operating Parameters
- ▶ Optional Time-Base Interconnect for Synchronization Between Multiple Controllers
- ▶ Fault Event Data Logging
- ▶ Capable of Standalone Operation via EEPROM Configuration
- ▶ High Speed SPI for VOUT adjust (LTC3888)
- ▶ PMBus Revision 1.2 Compliant Interface up to 400 kHz

The PMBus interface provides access to important power management data during system operation including:

- ▶ Average Input Voltage
- ▶ Average Output Voltages
- ▶ Average Output Currents
- ▶ PWM Operating Frequency
- ▶ Internal Device Temperature
- ▶ External Sensed Temperatures
- ▶ Warning and Fault Status, Including Input and Output Undervoltage and Overvoltage

The LTC3888 supports four PMBus bus addressing schemes to access the individual PWM voltage loops separately or jointly.

Fault reporting and system response behavior are fully configurable. The two status outputs ($\overline{\text{FAULT0}}$, $\overline{\text{FAULT1}}$) can be controlled independently. A separate $\overline{\text{ALERT}}$ pin also provides a maskable SMBALERT#. Fault responses for each channel may be individually programmed, depending on the fault type. PMBus status commands allow fault reporting over the serial bus to identify a specific fault event.

MAIN CONTROL LOOP

The LTC3888 utilizes constant frequency current mode control with trailing-edge modulation. The main control loop used for each master channel is illustrated in [Figure 34](#) and [Figure 35](#). During normal operation the top MOSFET in the external power stage

THEORY OF OPERATION

(power switch) driving choke L1 is commanded on when the clock phase for that master sets the RS latch, unless the main PWM comparator ICMP indicates there is already too much current in L1. In that case, no additional energy is delivered to the choke during that cycle (PWM output remains low, cycle skipped). Otherwise the latch is reset and power switch commanded off later in the cycle by the PWM comparator. Sensed output current is provided from the external power stage at the I_{SENSE} pin. The point in the PWM cycle at which ICMP resets the RS latch is controlled by the I_{TH} voltage provided by the output of error amplifier EA, including internal slope compensation for stable operation regardless of duty cycle. In steady state, I_{TH} adjusts the PWM duty cycle to match the FB (LTC3888) and V_{FB} (LTC3888-1) voltage to the EA positive terminal voltage.

The positive terminal of EA is connected to the output of a 12-bit DAC with values ranging from 0 V to approximately 1.22 V. The DAC value is determined by command values retrieved from internal EEPROM or by a combination of PMBus commands to synthesize the desired output voltage. The factory default EEPROM sets the value of this DAC output to 400 mV. The EA then regulates the output voltage based on the ratio of external resistors R1 and R2.

If load current increases, V_{SENSE}^+ and thus FB (LTC3888/LTC3888-2) and V_{FB} (LTC3888-1) will droop slightly, FB (LTC3888/LTC3888-2) and V_{FB} (LTC3888-1) with respect to the 12-bit DAC

output. This causes the I_{TH} voltage to increase until the average inductor current matches the new load current and the desired output voltage is restored. I_{TH} is monitored to provide programmable over-current protection with comparator ILIM.

When the top MOSFET is commanded off by the PWM output, the bottom MOSFET is commanded on. The LTC3888 operates in continuous conduction mode (CCM), so the bottom MOSFET stays on until the PWM clock next turns on the top MOSFET or the rail is commanded off.

POWER-UP AND INITIALIZATION

The LTC3888 is designed to provide standalone supply sequencing with controlled turn-on and turn-off functions. It operates from a V_{IN} supply of 4.5 V to 26.5 V while three on-chip linear regulators generate internal 2.5 V, 3.3 V, and 5.2 V. If V_{IN} is below 6 V, the V_{IN} and $INTV_{CC}$ pins must be shorted together and limited to a maximum operating voltage of 5.5 V. Controller configuration is reset by the internal UVLO threshold, where $INTV_{CC}$ must be at or above 4.45 V, V_{DD33} must be at or above 3.1 V and the internal 2.5 V supply must be within about 20% of its regulated value. V_{IN} must simply be high enough for the LDO outputs to reach these voltages. At that point the internal microcontroller begins initialization. A `RESTORE_USER_ALL` or `MFR_RESET` forces this same initialization.

THEORY OF OPERATION

key parameters such as output current limit programmable using external configuration resistors, it is possible to create complex PolyPhase rail solutions without needing to connect the device to any digital bus. Refer to the [Applications Information](#) section for more details on using analog output voltage control with default factory EEPROM settings.

PMBUS OUTPUT VOLTAGE CONTROL (LTC3888-1)

Once external programming resistors R1 and R2 ([Figure 34](#)) are chosen, it is possible to also use the full range of digitally programmed output voltage control found on most ADI PSM controllers. This is accomplished by specifying the external divider gain with VOUT_SCALE_LOOP. Again, refer to [Applications Information](#) section for complete details on controlling output voltage using built-in LTC3888-1 PMBus commands and features.

SOFT-START

The internal microcontroller typically requires 35 ms to complete initialization once all onboard supplies are above their UVLO threshold. After MCU initialization, an internal comparator monitors V_{IN} , which must exceed the VIN_ON threshold before output power sequencing can begin. SHARE_CLK is released to run and the RUN pins are released for external control after the part initializes and V_{IN} is greater than the VIN_ON threshold. Accurate readback telemetry can then require an additional 90 ms for initial round-robin A/D conversions.

If multiple LTC3888 ICs are used in an application, shared RUN pins are held low until all units initialize and V_{IN} exceeds the VIN_ON threshold for all devices. A common SHARE_CLK signal can also ensure all connected devices use the same time reference for initial start-up even if RUN pins cannot be shared due to other design requirements. SHARE_CLK is released by each IC once the conditions for power sequencing have been fully satisfied, regardless of RUN pin state.

After a channel RUN pin rises above 2 V and any specified turn on delay (TON_DELAY) has expired, the LTC3888 performs an initial monotonic soft-start ramp on that channel, allowing inrush current control. This is carried out with a digitally controlled ramp of the internal EA reference voltage from 0 mV to the commanded value (400 mV factory default) at the VOUT_TRANSITION_RATE (LTC3888-1) or TON_RISE (LTC3888/LTC3888-2). The soft-start feature is disabled by setting the value of VOUT_TRANSITION_RATE to 4 V/ms (LTC3888-1) or TON_RISE less than 250 μ s (LTC3888/LTC3888-2). The LTC3888 does not initiate PWM operation until the commanded output exceeds the actual rail voltage and I_{TH} has risen to a level that will avoid negative average choke current. This allows the regulator to start up into a prebiased load.

TIME-BASED OUTPUT SEQUENCING

The LTC3888 supports time-based output on and off sequencing using a shared time reference (SHARE_CLK). Following a qualified command to turn on, each output is enabled after waiting its programmed TON_DELAY. This can be used to sequence outputs in a prescribed order that can be reprogrammed as needed without hardware modification. Channel off-sequencing is accomplished in a similar way with the TOFF_DELAY command.

OUTPUT RAMPING CONTROL

The LTC3888 supports synchronized output on and off ramping control using a shared time reference (SHARE_CLK). Power rail on and off relationships similar to those of conventional analog tracking functions can be achieved by using programmed delays and VOUT_TRANSITION_RATE (LTC3888-1) or TON_RISE (LTC3888/LTC3888-2). With LTC3888 digital control, ramping configurations can be reprogrammed as needed without hardware modification.

Programmable fault responses and fault sharing can ensure that any desired time-based output sequencing and ramping control is properly accomplished each time the system powers up or down. Refer to the [Applications Information](#) section for various LTC3888 hardware and PMBus command configurations needed to fully support synchronization for time-based sequencing and output ramping when using multiple ICs.

VOLTAGE-BASED OUTPUT SEQUENCING

It is also possible to sequence outputs on using cascaded voltage events. To do this, the PGOOD status pin of one PWM channel can be used to control the RUN pin of a downstream channel. The controlling PGOOD pin holds RUN low if V_{OUT} is below the VOUT_UV_FAULT_LIMIT or if power-good conditions are not being met. This keeps the downstream channel off until acceptable output conditions exist on the controlling channel. The LTC3888 does not readily support voltage-based off-sequencing. Refer to the [Applications Information](#) section for more details on voltage-based sequencing.

OUTPUT DISABLE

All PWMs on the IC are disabled any time V_{IN} is below the VIN_OFF threshold. The power stages are immediately shut off to stop the transfer of energy to the load(s) as quickly as possible.

PWM channels may also be disabled in response to certain internal fault conditions, an external fault propagated through a FAULT pin, or loss of SHARE_CLK. In these cases the power stages are immediately commanded off to stop the transfer of energy to the load as quickly as possible. Refer to the following Fault Detection and Handling section for additional details related to fault recovery.

Each rail can be disabled with an OPERATION command at any time if enabled by ON_OFF_CONFIG. This will force a controlled turn-off response with defined delay (TOFF_DELAY)

THEORY OF OPERATION

and ramp down rate (VOUT_TRANSITION_RATE, LTC3888-1 or TOFF_FALL, LTC3888/LTC3888-2).

Finally, each rail can be commanded off by pulling the associated RUN pin low. Pulling the RUN pin low can force the master to perform a controlled turn off or immediately disable all rail power stages, depending on the programming of ON_OFF_CONFIG.

Minimum Output Disable Times

When OPERATION is used to turn off an LTC3888 rail, a minimum output disable time of 120 ms is imposed regardless of how quickly the rail is commanded back on. If bit 4 of MFR_CHAN_CONFIG is clear, a PMBus command to turn the channel off also pulses the RUN pin low. Once the RUN pin is pulled low internally or externally, a minimum output disable time (RUN forced low by the LTC3888) of TOFF_DELAY + V_{OUT}/VOUT_TRANSITION_RATE + 136 ms (LTC3888-1) or TOFF_DELAY+TOFF_FALL + 136 ms (LTC3888/LTC3888-2) is enforced. If MFR_RESTART_DELAY is greater than this mandatory minimum, the larger value of MFR_RESTART_DELAY is used. These minimum off times allow a consistent rail restart with coherent monitor ADC values and make the LTC3888 highly compatible with other ADI PMBus digital power system management products.

OUTPUT SHORT CYCLE

An output short cycle condition is created when a master channel is commanded back on while waiting for controlled turn off to complete based on TOFF_DELAY and VOUT_TRANSITION_RATE (LTC3888-1) or TOFF_FALL (LTC3888/LTC3888-2). Any time this occurs, the LTC3888 asserts the short cycle bit in STATUS_MFR_SPECIFIC. Device response at that point is governed by bits in MFR_CHAN_CONFIG and SMBALERT_MASK. Refer to the detailed descriptions of those commands for additional details. Generally, the LTC3888 should be controlled so that short cycle conditions are not created during normal operation.

SWITCHING FREQUENCY AND PHASE

There is a high degree of flexibility for setting the PWM operating frequency of the LTC3888. The switching frequency of the PWM can be established with an internal oscillator or an external time base. The internal phase-locked loop (PLL) synchronizes PWM control to this timing reference with proper phase relation. The device can also be configured to provide the master clock (SYNC) to other ICs through PMBus command or EEPROM setting. The LTC3888 is designated as a clock master by clearing bit 4 of MFR_CONFIG_ALL. As clock master, the LTC3888 will drive its open-drain SYNC pin at the selected rate with a pulse width of 500 ns. An external pull-up resistor between SYNC and V_{DD33} is required in this case. Only one device connected to SYNC should be designated to drive the pin. If more than one LTC3888 sharing SYNC is programmed as clock master, just one of the devices is automatically elected to provide the clock. The others disable their SYNC outputs and indicate this with bit 10 of MFR_PADS_LTC3888.

The LTC3888 will automatically accept an external SYNC input, disabling its own SYNC drive if necessary, as long as the external clock frequency is greater than one-half of the programmed internal oscillator. Whether configured to drive SYNC or not, the LTC3888 will continue PWM operation at the selected frequency (FREQUENCY_SWITCH) using its own internal oscillator if an external clock signal is subsequently lost.

The MFR_PWM_CONFIG_LTC3888 command can be used to create a specific master/slave configuration and assign the phase of each channel. Desired master/slave arrangement can also be set from EEPROM or external configuration resistors as outlined in [Table 15](#). Phase designates the relationship between the falling edge of SYNC and the internal clock edge that sets the PWM latch for that channel. Additional small propagation delays to the PWM control pins will apply.

PWM phase relationships and frequency are independent of each other, providing numerous application options. Multiple LTC3888 ICs can be synchronized to realize a PolyPhase array. Two LTC3888 devices can be combined to expand phase count while maintaining ideal phase separation of 360/n degrees, where n is the number of phases driving the output voltage rail. Refer to the [Applications Information](#) section for additional details.

POLYPHASE LOAD SHARING

Multiple LTC3888 devices can be combined to provide a balanced load-share solution by configuring the necessary pins. The SHARE_CLK and SYNC pins of all load-sharing ICs should be bussed together. Connecting the SYNC pins synchronizes the PWM controllers with each other. Bussing the SHARE_CLK pins together allows the phases to start synchronously. Refer to the discussion in the previous [Power-Up and Initialization](#) section. The last device to see all start-up conditions satisfied controls the initiation of power sequencing for all phases.

The outputs of multiple LTC3888 error amplifiers (I_{TH} pins) may be wired together in large PolyPhase applications if V_{OUT} sensing for those channels is also shared. The error amplifier of only one master phase can also be designated for voltage control by redefining any remaining master phases as slaves using bit 4 of MFR_PWM_MODE_LTC3888. Additional details for properly constructing various PolyPhase designs are covered in the [Applications Information](#) section.

VOLTAGE CONTROL LOOP COMPENSATION

Because the LTC3888 uses an operational transconductance amplifier (OTA) architecture for its error amplifier, Type II compensation is most commonly applied for stabilizing the voltage control loop. The LTC3888 offers several programmable features for flexibility in designing and operating the PWM with optimum transient behavior over a wide range of output capacitance without additional hardware changes.

Bits[4:0] of MFR_PWM_COMP adjust an internal resistor which can be used to set the dominant zero against the primary compensation

THEORY OF OPERATION

capacitance. This resistance appears between the I_{TH} and I_{THR} pins.

The transconductance of the error amplifier itself can also be adjusted using bits[7:5] of MFR_PWM_COMP.

Both of these parameters can be modified when the device is in operation, affording real-time evaluation of compensation settings. Refer to the [Applications Information](#) section for additional details related to loop compensation.

LOAD STEP EMULATION

Basic assembly integrity, PWM regulator loop response, and passive component aging or thermal degradation are best evaluated by analyzing load current transient response. The LTC3888 features a flexible load step emulation capability that allows in-situ transient response evaluation without the need to actually generate and apply large, regulated load current pulses at the regulator output. These features can find use in the design, debug, prototyping and preventative maintenance phases of a product life cycle.

Load step emulation is controlled by MFR_LOAD_EMULATION. All phases associated with each master channel can be programmed to emulate a load step of known amplitude (bits[1:0]). Bit 2 of the command determines whether the emulated load is applied as a continuous increase or as a 100 μ s pulse. Because internal application of data from a PMBus command is an asynchronous event, bit 3 of the command allows the PGOOD output to be repurposed to provide a trigger at the actual start of the emulated load step, if necessary.

INPUT SUPPLY MONITORING

The input supply voltage is sensed by the LTC3888 at the V_{IN} pin. Undervoltage, overvoltage, and valid on/off levels can be programmed for V_{IN} . Refer to the following [PMBus Command Details](#) section for more information on programming input supply thresholds. In addition, the telemetry ADC monitors V_{IN} relative to GND. Conversion results are returned by READ_VIN.

OUTPUT VOLTAGE SENSING AND MONITORING

Both on-chip voltage control loops allow remote, differential sensing of the load voltage with $V_{SENSE\pm}$ pins. The amplifier outputs provide a 1X buffered version of this sensed differential referenced to package GND. These outputs are suitable for driving a resistor divider to GND supplying FB (LTC3888/LTC3888-2), V_{FB} (LTC3888-1) to set the desired output voltage.

V_{OUT} supervisor UV and OV fault limits are set from EEPROM or PMBus command. Factory EEPROM sets the supervisor limits and margin values as a percentage of V_{OUT} (LTC3888/LTC3888-2), V_{FB} (LTC3888-1) and hence V_{OUT} . If these are modified by PMBus command, they are specified in absolute volts.

The telemetry ADC is also fully differential and makes measurements of regulated output voltages at $V_{SENSE\pm}$. Conversion results are returned by READ_VOUT.

OUTPUT CURRENT SENSING AND MONITORING

Every PWM channel on the LTC3888 accepts an output current monitor signal from the power stage it controls. A proprietary input interface uses this information to control output pulse width on that phase. When the I_{SENSE} pins for a channel are multiplexed to the differential inputs of the LTC3888 monitor ADC, they use IREF as the negative input. These ADC channels have a differential input range of approximately ± 400 mVDC. The internal ADC anti-aliasing filter and conversion rate produce an average reading of the I_{SENSE} input voltage relative to IREF. The resulting value is returned by the READ_IOUT PMBus command. To allow reduction in round-robin latency, bit 6 of MFR_PWM_CONFIG_LTC3888 determines if the ADC converts I_{SENSE} for all eight phases, or only the two master channels. If only I_{SENSE0} and I_{SENSE1} are monitored, the IOUT results for the remaining six channels are set to 0 A. READ_IOUT returns readings for the two master channels, MFR_TOTAL_IOUT returns the sum of all output currents for on-chip phases assigned to each master channel, and MFR_READ_ALL_IOUT returns output current for each individual phase using block read format.

TEMPERATURE SENSE

External temperature can be monitored by most modern power stages. This is normally presented on a highest-indicated wire-OR analog bus for each rail, where the device with highest internal temperature sets the bus voltage. The internal ADC converts these temperature inputs at one-third the rate of voltage or current channels, and those results are returned by READ_TEMPERATURE_1. READ_TEMPERATURE_2 returns the internal junction temperature of the LTC3888 using an on-chip diode with accurate ΔV_{BE} measurement and calculation.

RESISTOR CONFIGURATION PINS

Six input pins can be used to configure key operating parameters with selected 1% resistors between each pin and GND. R_{SET} establishes the proper bias levels for the remaining five pins and requires an 18.7 k Ω resistor to GND. The remaining RCONFIG pins are ASEL0, ASEL1, VOUT0_CFG, VOUT1_CFG (LTC3888/LTC3888-2) or ILIM0_CFG, ILIM1_CFG (LTC3888-1), and PWM_CFG. If any of these five pins are left open, the value stored in the corresponding EEPROM command(s) is used. The resistor configuration pins are only measured during power-up and execution of RESTORE_USER_ALL or MFR_RESET. If bit 6 of MFR_CONFIG_ALL is set in EEPROM, all resistor configuration pins except ASEL0 and ASEL1 are ignored. Per the PMBus specification, all pin-programmed parameters can be overridden at any time by commands from the digital interface.

The ASEL0/1 pin settings are described in application [Table 16](#). These pins can be used to select the entire LTC3888 device

THEORY OF OPERATION

address. ASEL0 always programs the bottom four bits of the device address for the LTC3888 unless left open. ASEL1 can be used to program the three most-significant bits. Either portion of the address can also be retrieved from the MFR_ADDRESS value in EEPROM. If both pins are left open, the full 7-bit MFR_ADDRESS value stored in EEPROM is used to determine the device address. The LTC3888 always responds to 7-bit global addresses 0x5A and 0x5B. MFR_ADDRESS should not be set to either of these values or 0x7C.

The VOUT0_CFG and VOUT1_CFG (LTC3888/LTC3888-2) or the ILIM0_CFG and ILIM1_CFG (LTC3888-1) pin settings are described in application [Figure 56](#). These pins select the per-phase output voltage (LTC3888/LTC3888-2) or current limit (LTC3888-1) for each related rail.

For more details on the LTC3888-1 voltage settings refer to the [Classical Analog Output Voltage Control \(LTC3888-1\)](#) section. For the LTC3888 the VOUTn_CONFIG pins set the desired output voltage. In addition, the following parameters are set as a percentage of the programmed VOUT.

- ▶ VOUT_OV_FAULT_LIMIT: +10%
- ▶ VOUT_OV_WARN+LIMIT: +7.5%
- ▶ VOUT_MARGIN_HIGH: 5%
- ▶ VOUT_MARGIN_LOW: -5%
- ▶ VOUT_UV_WARN_LIMIT: -6.5%
- ▶ VOUT_UV_FAULT_LIMIT: -7.5%

PWM_CFG pin settings are described in application [Table 15](#). This pin selects the master/slave configuration and switching frequency of the internal oscillator.

INTERNAL EEPROM WITH CRC

The LTC3888 contains internal EEPROM with error correction code (ECC) to store user configuration settings and fault log information. EEPROM endurance and retention for user space and fault log pages are specified in the [Absolute Maximum Ratings](#) section and [Table 2](#).

The integrity of the entire onboard EEPROM is checked with a CRC calculation each time its data is to be read, such as after a power-on reset or execution of RESTORE_USER_ALL. If a CRC error occurs, the CML bit is set in STATUS_BYTE and STATUS_WORD, the EEPROM CRC Error bit in STATUS_MFR_SPECIFIC is set, and the ALERT, SHARE_CLK and RUN pins are pulled low (PWM channels off). At that point the device will respond at special address 0x7C, which is activated after an invalid CRC has been detected. The chip no longer responds at its specifically assigned address, but will still respond at global addresses 0x5A and 0x5B. However, use of these global addresses when attempting to recover from a CRC issue is not recommended. All power supply rails associated with a device reporting an invalid CRC should remain disabled until the issue is resolved.

ADI recommends that the EEPROM not be written when die temperature is greater than 85°C. If internal die temperature exceeds 130°C, all EEPROM operations except RESTORE_USER_ALL and MFR_RESET are disabled. Full EEPROM operation is not re-enabled until die temperature falls below 125°C. Refer to the [Applications Information](#) section for equations to predict retention degradation due to elevated operating temperatures.

See the [Applications Information](#) section or contact the factory for details on efficient in-system EEPROM programming, including bulk EEPROM programming, which the LTC3888 also supports.

FAULT DETECTION

A variety of fault and warning detection, reporting and handling mechanisms are provided by the LTC3888. Fault or warning detection capabilities include:

- ▶ Input Under/Overvoltage
- ▶ Power Stage UV or Fault
- ▶ Output Under/Overvoltage
- ▶ Output Overcurrent
- ▶ External Overtemperature
- ▶ Internal Overtemperature
- ▶ CML Fault (Communication, Memory, or Logic)
- ▶ External Fault Detection via Bidirectional FAULT Pins

Reporting is covered in following sections on status commands (registers) and ALERT pin function. Fault handling mechanisms include hardwired low level PWM safety responses that always occur and higher-level programmable event management. Both types are covered in the following sections.

Input Supply Faults

Input undervoltage and overvoltage limits are determined from multiplexed monitor ADC conversions. Therefore the input UV/OV response is naturally deglitched by the typical conversion cycle of the ADC (tens of milliseconds). There is no hardwired low level PWM response for any input supply fault.

Hardwired PWM Response to Power Stage Faults

Power stage faults are monitored on the shared TEMP/FAULT bus attached to an LTC3888 TSNS pin. A power stage fault condition is detected if this bus is pulled above any voltage expected for normal operating temperature range. The specific faults that are reported are determined by the power stage manufacturer. When a power stage fault is detected, the master and its associated slave channels are all commanded off. This state is indicated in the LTC3888 status registers and optionally on the ALERT pin. The off condition is latched until the rail is turned off and then back on by the RUN pin or OPERATION command, including IC reset or power supply cycling.

THEORY OF OPERATION

Hardwired PWM Response to Power Stage UV

Some power stages can also report a undervoltage condition for their input supplies on the shared TEMP/FAULT bus. When supported, this condition is indicated by pulling the bus below any voltage expected for normal operating temperature range. The LTC3888 recognizes this UV indication if enabled by bit 0 of MFR_PWM_MODE_LTC3888.

If the power stage does not provide inherent UV indication on a shared TEMP/FAULT bus, the LTC3888 can be programmed to provide additional power stage undervoltage detection by setting bit 5 of MFR_CHAN_CONFIG on Page 0. Pin 8 is then converted to a VDR_MON input to monitor the FET gate drive supply voltage (VDR) of the external power stages for both master channels. Normally an external resistor divider to set the desired UV threshold is required. In this case TSNS1 serves as connection for the shared TEMP/FAULT bus for both master channels with UV detection disabled, regardless of the state of bit 0 of MFR_PWM_MODE_LTC3888 on either page.

When TSNS-based UV detection or VDR_MON are enabled, power stage UV condition is continuously indicated in bits[15:14] of MFR_PADS_LTC3888. If a power stage UV condition then occurs during PWM operation or is present when the PWM master is commanded to start, the master and its associated slave channels are all latched off. This state is indicated in the LTC3888 status registers and optionally on the ALERT pin. The off condition is latched until the rail is turned off and then back on by the RUN pin or OPERATION command, including IC reset or power supply cycling.

Note that if an enabled power stage UV indication exists on both master channels that are sequentially turned on by RUN pin or OPERATION command, the indicated fault on the first channel on will be cleared if bit 0 of MFR_CONFIG_ALL is set. However, both channels will be latched off as described above.

Hardwired PWM Response to VOUT Faults

V_{OUT} undervoltage (UV) and overvoltage (OV) faults are detected by supervisor comparators. The output overvoltage comparator guards against transient overshoots as well as long term overvoltages at the output. When an output OV fault is detected, the state is indicated in the LTC3888 status registers and optionally on the ALERT pin. The master and its associated slave channels are all commanded off, unless bit 4 of MFR_PWM_CONFIG_LTC3888 is set and bit 4 in the associated MFR_PWM_MODE_LTC3888 command is clear. In that special case the master phase of the OV rail commands its power stage to drive low as long as the OV condition is detected. Regardless, the off condition is latched until the rail is cycled off and then back on after the fault has cleared.

UV faults are masked if the channel has been commanded off or until all of the following criteria are achieved.

- ▶ TON_DELAY Has Expired

- ▶ The Soft-Start Ramp Has Completed
- ▶ TON_MAX_FAULT_LIMIT Has Been Reached
- ▶ IOUT_OC_FAULT_LIMIT Has Not Been Reached
- ▶ Soft-Off Is Not in Progress

The LTC3888 has no hardwired PWM response for output UV faults.

The LTC3888 supports optional output UV and OV warnings that are determined from multiplexed monitor ADC conversions. The LTC3888 has no hardwired PWM response for output UV or OV warnings.

Power Good Indication

An LTC3888 master phase indicates Power Good on its PGOOD pin and in STATUS_WORD based on selected UV and OV fault limits. Power Good is indicated as long as the phase is enabled to run and V_{OUT} is between the UV and OV fault limits.

Hardwired PWM Response to I_{OUT} Faults

The LTC3888 monitors output current as commanded by the I_{TH} pins, taking into account power stage current monitor gain, which is provided by PMBus command or EEPROM values.

An output overcurrent (OC) fault condition is detected by a supervisor comparator for each master channel when the I_{TH} voltage for that channel reaches its maximum allowed value. Refer to IOUT_OC_FAULT_LIMIT for details. When an OC fault is detected the controller clamps I_{TH} at the OC value.

Output OC warnings are determined from multiplexed monitor ADC conversions. The LTC3888 has no hardwired PWM response if an output OC warning occurs.

Hardwired PWM Response to Internal Temperature Faults

An internal temperature sensor measured by the monitor ADC protects against EEPROM and other IC damage. When die temperature rises above 130°C, the LTC3888 will NACK any EEPROM-related command except RESTORE_USER_ALL and MFR_RESET and issue a CML fault for Invalid/Unsupported Command. Normal EEPROM access is re-enabled when die temperature drops below 125°C. Above 160°C, the part shuts down all PWM outputs until die temperature is below 150°C. Internal temperature fault limits cannot be adjusted. Writing to the EEPROM above a die temperature of 85°C is strongly discouraged. Refer to the [Absolute Maximum Ratings](#) section for other important temperature limitations on internal EEPROM use.

External Temperature Faults

The external shared (wire-OR) power stage temperature bus may also be monitored by the onboard ADC. There is no hardwired PWM response for sensed external temperature faults or warnings.

THEORY OF OPERATION

Timing Faults

There is no hardwired PWM response to any timing faults.

TON_MAX_FAULT_LIMIT is the time allowed for V_{OUT} to rise and settle at start-up. The TON_MAX_FAULT_LIMIT timer, which has a resolution of 10 μ s, is started after TON_DELAY has been reached and a soft-start sequence is started. If the VOUT_UV_FAULT_LIMIT is not reached or an OC fault remains after the specified time, fault response is determined by the value of TON_MAX_FAULT_RESPONSE.

An internal watchdog detects if SHARE_CLK remains low for more than 64 μ s. The part then actively holds SHARE_CLK low for 120 ms, ensuring all devices connected to this shared control observe a minimum RETRY_DELAY event. The LTC3888 sets the SHARE_CLK_LOW bit in MFR_COMMON to indicate this fault condition.

External Faults

There are no hardware-level responses to any external faults propagated into the IC through the FAULT pins.

HIGHER-LEVEL FAULT HANDLING

Higher-level input and output fault event handling (response) can be programmed as described in the following [PMBus Command Details](#) section. Once a fault is detected, several tens of microseconds may be required for these higher level responses to occur, including related assertion of a FAULT output. Time filtering programmed in any specific fault response will be in addition to these normal processing delays. For many faults, the LTC3888 can manage response in one of three ways: ignore, autonomous recovery (hiccup), or latch off. The device takes no additional action beyond previously discussed hardware-level responses when programmed to ignore a fault.

For autonomous recovery a new soft-start is attempted if the fault condition is not present after the MFR_RETRY_DELAY interval has elapsed. MFR_RETRY_DELAY can be set from 120 ms to 83 seconds in 1 ms increments. If the fault persists, the controller will continue to retry with an interval specified by MFR_RETRY_DELAY. This avoids damage to external regulator components caused by repetitive, rapid power cycling.

No retry is attempted for a latch off fault response. In the latch off state the applicable external power stages are immediately disabled to stop the transfer of energy to the load as quickly as possible. The output remains disabled until the master channel is commanded off and then on, or IC supply power is cycled. Commanding a

PWM channel off and on may require software and/or hardware intervention depending on its programmed configuration.

The RUN pin must be released by any controlling external application circuits for that channel to restart from the latch off state. As the RUN pin for a given rail rises, associated internal fault indications are cleared automatically. The LTC3888 can also be programmed to clear faults for both master channels based solely on the run state of just one channel. See the [MFR_CONFIG_ALL](#) command. CLEAR_FAULTS can also be used to clear all fault bits at any time, independent of PWM channel state.

Higher-level handling of some internally generated faults can be digitally deglitched. External faults propagated into the chip using FAULT pins are not deglitched. Refer to the following section on [FAULT Pin I/O](#).

STATUS REGISTERS AND ALERT MASKING

[Figure 36](#) summarizes the internal LTC3888 status registers accessible by PMBus command. These contain indication of various faults, warnings and other important operating conditions. As shown, STATUS_BYTE and STATUS_WORD also summarize contents of other status registers. Refer to [PMBus Command Details](#) section for specific information.

NONE OF THE ABOVE in STATUS_BYTE indicates that one or more of the bits in the most-significant nibble of STATUS_WORD are also set.

[Figure 36](#) also shows which of the status bits will assert ALERT if set and not masked. Once set, ALERT will remain low until one of the following occurs.

- ▶ A CLEAR_FAULTS, RESTORE_USER_ALL or MFR_RESET Command Is Issued
- ▶ The Related Status Bit Is Written to a One
- ▶ The Faulted Channel Is Properly Commanded Off and Back On
- ▶ The LTC3888 Successfully Transmits Its Address During a PMBus Alert Response Address (ARA)
- ▶ IC Supply Power Is Cycled

With some exceptions, the SMBALERT_MASK command can be used to prevent the LTC3888 from asserting ALERT on a bit-by-bit basis by register. These mask settings are promoted to STATUS_WORD and STATUS_BYTE in the same fashion as the status bits themselves. For example, if ALERT is masked for all bits in Channel 0 STATUS_VOUT, then ALERT is effectively masked for the VOUT bit in STATUS_WORD for PAGE 0.

THEORY OF OPERATION

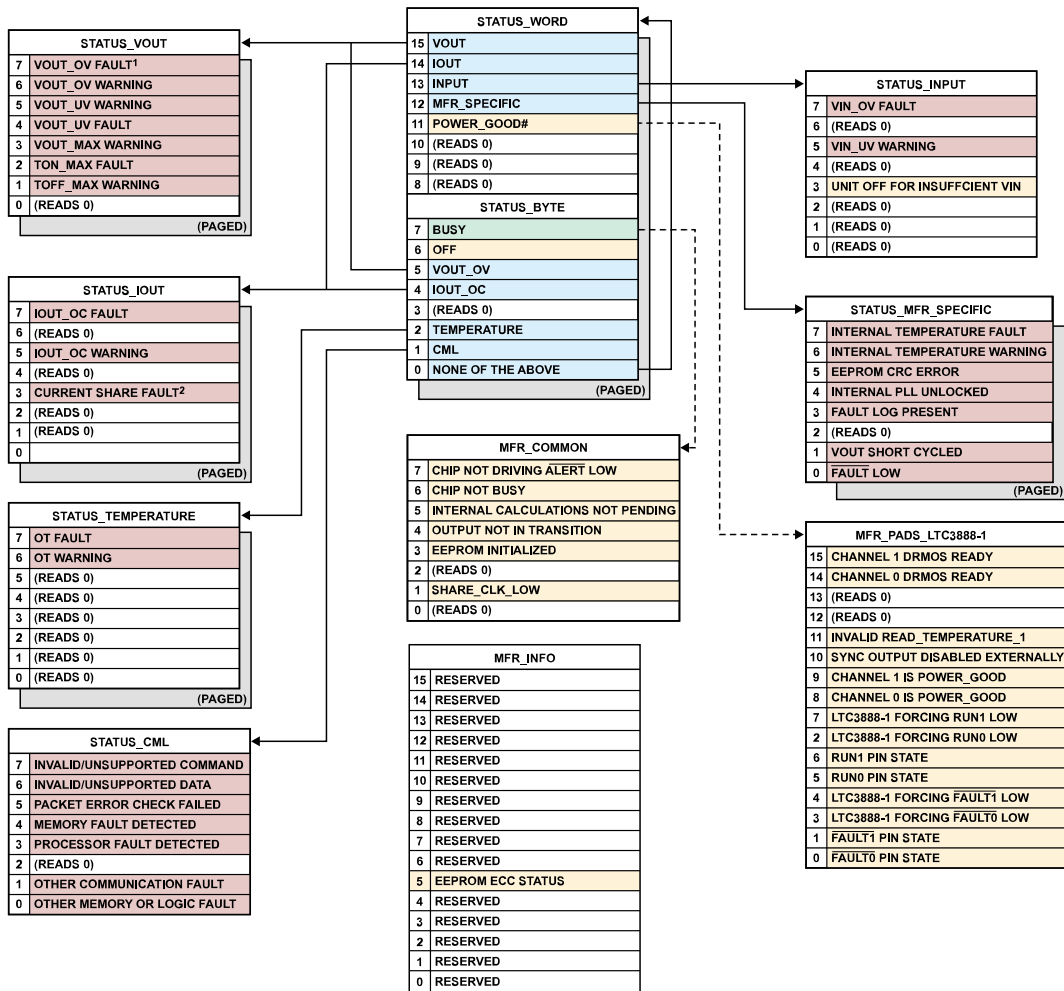

DESCRIPTION	MASKABLE	GENERATES ALERT	BIT CLEARABLE
GENERAL FAULT OR WARNING EVENT	YES	YES	YES
GENERAL NON-MASKABLE EVENT	NO	YES	YES
DYNAMIC	NO	NO	NO
STATUS DERIVED FROM OTHER BITS	NO	NOT DIRECTLY	NO

¹SET BY VOUT_OV, DR MOS (POWER STAGE) FAULT OR DR MOS UVLO DURING RUN
²SET ONLY BY DETECTED POWER STAGE FAULT

Figure 36. LTC3888-1 Status Register Summary

THEORY OF OPERATION

The `BUSY` bit in `STATUS_BYTE` also asserts $\overline{\text{ALERT}}$ and cannot be masked. This bit can be set as a result of interaction between internal operations and PMBus communication. This fault occurs when a command is received that cannot be safely executed with one or both master channels enabled. As discussed in [Applications Information](#) section, `BUSY` faults can be avoided by polling `MFR_COMMON` before executing some commands.

Status information contained in `MFR_COMMON` and `MFR_PADS_LTC3888` can be used to clarify the contents of `STATUS_BYTE` or `STATUS_WORD` as shown, but the contents of these registers do not affect the state of the $\overline{\text{ALERT}}$ pin and may not directly influence bits in `STATUS_BYTE` or `STATUS_WORD`.

FAULT PIN I/O

The LTC3888 can map various fault indicators to their respective $\overline{\text{FAULT}}$ pin using the `MFR_FAULT_PROPAGATE` command.

Channel-to-channel fault dependencies and communication can be created by connecting $\overline{\text{FAULT}}$ pins together. In the event of an internal fault, one or more of the channels is configured to pull the bussed $\overline{\text{FAULT}}$ pins low. All channels are then configured to shut down when the bussed $\overline{\text{FAULT}}$ pins are pulled low (`MFR_FAULT_RESPONSE` set to `0xC0`). If latch off is the programmed response on the faulted channel, the $\overline{\text{FAULT}}$ pin remains low until one of the following occurs:

- ▶ A `CLEAR_FAULTS`, `RESTORE_USER_ALL` or `MFR_RESET` Command Is Issued
- ▶ The Related Status Bit Is Written to a One
- ▶ The Faulted Channel Is Properly Commanded Off and Back On
- ▶ IC Supply Power Is Cycled

For autonomous group retry, the faulted channel is configured to release the $\overline{\text{FAULT}}$ pin(s) after a retry interval, assuming the original fault has cleared. All the channels in the group then begin a soft-start sequence.

As noted above, $\overline{\text{FAULT}}$ pins can also find use as inputs to detect faults external to the controller that require an immediate response. External faults propagated into the chip using $\overline{\text{FAULT}}$ pins are not deglitched.

Refer to [MFR_FAULT_PROPAGATE](#) for additional details.

FAULT LOG OPERATION

The LTC3888 supports fault logging to provide telemetry recording capability. A conceptual diagram of the fault log is shown in [Figure 37](#). During normal operation the contents of primary status registers and all ADC readings, including peak voltage and current results, are stored in a continuously updated RAM buffer if enabled by bit 7 of `MFR_CONFIG_ALL`. The operation is similar to a strip recorder. When a fault occurs that disables either master channel, recording to internal memory is halted (locked) and the fault log information is made available from RAM via the `MFR_FAULT_LOG` command.

Some contents of the locked RAM fault log are also copied into EEPROM for nonvolatile storage. See [Fault Log Details](#) section.

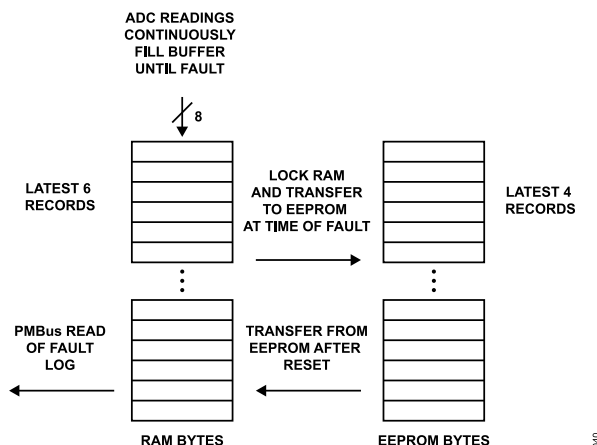

Figure 37. Fault Log Conceptual Diagram

A fault log write to EEPROM is allowed above a die temperature of 85°C , but 10 years of retention is not guaranteed. When die temperature exceeds 130°C , any EEPROM fault log storage is delayed until the temperature drops below 125°C .

Once created, a fault log cannot be overwritten by subsequent fault events, even if the log is only partial. An `MFR_FAULT_LOG_CLEAR` command must be executed to erase an existing log, leaving the IC free to generate a new one.

Faults propagated into the IC through $\overline{\text{FAULT}}$ pins do not trigger a fault logging event, regardless of their impact on PWM operation. Faults that generate a fault log should be fully cleared before the log is erased to prevent creation of spurious fault logs.

When the LTC3888 powers up it checks the EEPROM for a valid fault log. If one is found the Fault Log Present bit in `STATUS_MFR_SPECIFIC` is set. If the Memory Fault Detected bit is also set in `STATUS_CML`, then the stored fault log is partial. Data in one or more event records may be incomplete or incorrect.

Fault Log Details

The `MFR_FAULT_LOG` command uses a block read protocol with a fixed length of 147 bytes. The LTC3888 returns a block byte count of zero if a fault log is not present.

Contents of a fault log are shown in [Table 5](#) through [Table 8](#). Refer to [Table 10](#) for an explanation of data formats. Each event record represents one complete conversion cycle through all multiplexed monitor ADC inputs and related status. When a fault log is created the present ADC input cycle is completed and the ADC input being converted at the time of the fault is noted in the log header. Referring to [Figure 37](#), the six most recent event records are maintained in internal RAM in reverse chronological order. If input power is cycled or the part is reset after a fault log is created, the

THEORY OF OPERATION

RAM record is restored from EEPROM where only the four most recent events are retained due to available storage.

Table 5. LTC3888-1 Fault Log Contents

RECORD TYPE	STARTING BYTE	ENDING BYTE	COMMENTS
Header Information	0	26	See Table 6 .
Fault Event Record	27	46	Fault may have occurred anywhere during this event record. See byte 4 of Table 6 and all of Table 7 and Table 8 .
Event Record N-1	47	66	Last complete cyclical data read before the fault was detected.
Event Record N-2	67	86	Older data records...
Event Record N-3	87	106	
Event Record N-4	107	126	
Event Record N-5	127	146	Oldest recorded data.

Table 6. Fault Log Header Information

RECORD	BITS	FORMAT	BLOCK BYTE COUNT	DETAILS
Fault Log Preface	[7:0]	ASC	0	Returns LTxx beginning at byte 0 if a partial or complete fault log exists. Word xx is a factory identifier that may vary part to part.
	[7:0]		1	
	[15:8]	Reg	2	
	[7:0]		3	
Fault Source	[7:0]	Reg	4	Refer to Table 7 .
MFR_REAL_TIME	[7:0]	Reg	5	48 bit share-clock counter value when fault occurred (200µs resolution).
	[15:8]		6	
	[23:16]		7	
	[31:24]		8	
	[39:32]		9	
	[47:40]		10	
MFR_VOUT_PEAK (PAGE 0)	[15:8]	L16	11	Peak READ_VOUT on Channel 0 since last power-on or CLEAR_PEAKE command.
	[7:0]		12	
MFR_VOUT_PEAK (PAGE 1)	[15:8]	L16	13	Peak READ_VOUT on Channel 1 since last power-on or CLEAR_PEAKE command.
	[7:0]		14	
MFR_IOUT_PEAK (PAGE 0)	[15:8]	L11	15	Peak READ_IOUT on Channel 0 since last power-on or CLEAR_PEAKE command.
	[7:0]		16	
MFR_IOUT_PEAK (PAGE 1)	[15:8]	L11	17	Peak READ_IOUT on Channel 1 since last power-on or CLEAR_PEAKE command.
	[7:0]		18	
MFR_VIN_PEAK	[15:8]	L11	19	Peak READ_VIN since last power-on or CLEAR_PEAKE command.
	[7:0]		20	
READ_TEMPERATURE1 (PAGE 0)	[15:8]	L11	21	External temperature sensor 0 during last event.
	[7:0]		22	
READ_TEMPERATURE1 (PAGE 1)	[15:8]	L11	23	External temperature sensor 1 during last event.
	[7:0]		24	
READ_TEMPERATURE2	[15:8]	L11	25	Internal temperature sensor during last event.
	[7:0]		26	

Table 7. Fault Source Values

FAULT SOURCE VALUE	CAUSE OF FAULT LOG	CHANNEL
0x00	TON_MAX	0
0x01	VOUT_OV	
0x02	VOUT_UV	

THEORY OF OPERATION

Table 7. Fault Source Values (Continued)

FAULT SOURCE VALUE	CAUSE OF FAULT LOG	CHANNEL
0x03	IOUT_OC	1
0x05	Over Temperature	
0x07	VIN_OV	
0x0A	Internal Temperature	
0x10	TON_MAX	
0x11	VOUT_OV	
0x12	VOUT_UV	
0x13	IOUT_OC	
0x15	Over Temperature	
0x17	VIN_OV	
0x1A	Internal Temperature	
0xFF	MFR_FAULT_LOG_STORE	

Table 8. Fault Log Event Record

DATA	BITS	FORMAT	RECORD BYTE INDEX
READ_VOUT (PAGE 0)	[15:8]	L16	0
	[7:0]		1
READ_VOUT (PAGE 1)	[15:8]	L16	2
	[7:0]		3
MFR_TOTAL_IOUT (PAGE 0)	[15:8]	L11	4
	[7:0]		5
MFR_TOTAL_IOUT (PAGE 1)	[15:8]	L11	6
	[7:0]		7
READ_VIN	[15:8]	L11	8
	[7:0]		9
(Not used)	[15:8]	L11	10
	[7:0]		11
STATUS_VOUT (PAGE 0)	[7:0]	Reg	12
STATUS_VOUT (PAGE 1)	[7:0]	Reg	13
STATUS_WORD (PAGE 0)	[15:8]	Reg	14
	[7:0]		15
STATUS_WORD (PAGE 1)	[15:8]	Reg	16
	[7:0]		17
STATUS_MFR_SPECIFIC (PAGE 0)	[7:0]	Reg	18
STATUS_MFR_SPECIFIC (PAGE 1)	[7:0]	Reg	19

FACTORY DEFAULT OPERATION

The LTC3888 ships from the factory with a default configuration stored in its non-volatile memory unless custom programming has been requested. These command values are loaded into volatile RAM when the chip is initialized. Prior to receiving any PMBus commands, a stock LTC3888 will operate in the factory default mode. If a STORE_USER_ALL command is executed, the contents of the non-volatile memory are replaced with active command values from internal RAM, and that will permanently overwrite the factory defaults. Table 9 summarizes the default factory operation settings of the LTC3888 if all resistor configuration pins are left open. These defaults allow parameters listed in bold text in the table to be

overridden with configuration resistor programming. Warning limits are given in Table 9 because exceeding them will cause the ALERT pin to be asserted even if the PMBus interface is not being utilized.

THEORY OF OPERATION

Table 9. Factory Default Operation Summary

PARAMETER	DEFAULT SETTING	UNITS
PMBus Address ¹	All writes enabled to Channel 0 at address 0x4F (no PEC).	–
Operation	OPERATION enabled with RUN pin control and soft-off.	–
Input Voltage OFF Threshold	6.0	V
Input Voltage UV Warning Limit	6.3	V
Input Voltage ON Threshold	6.5	V
Input Voltage OV Fault Limit	15.5	V
Input Voltage OV Fault Response	Latch off	–
Soft-Start Time	1.6 (with no delay)	ms
Maximum Start-Up Time (TMAX)	10	ms
TMAX Fault Response	Retry every 350ms	–
Output Voltage UV Fault Limit	–10% of nominal V _{OUT}	–
Output Voltage UV Fault Response	Retry every 350 ms	–
Output Voltage	Set by RCONFIG or EEPROM (LTC3888/LTC3888-2) or external R-divider (V _{FB} = 400 mV, V _{OUT} servo disabled) LTC3888-1	–
Output Voltage OV Fault Limit	10% of nominal V _{OUT}	–
Output Voltage OV Fault Response	Latch off	–
Shut Down	1.6 ms soft-off	–
Output Current Monitor Gain	5.0	mΩ
Output Current OC Warning/Fault Limits ¹	20/29.75	A
Output Current OC Fault Response	Ignore	–
PWM Switching Frequency ¹	500	kHz
Master/Slave Configuration ¹	4+4 (or 8-phase)	–
Internal Overtemperature Warning/Fault Limits	130/160	°C
Internal Overtemperature Responses	Warning: EEPROM disabled; Fault: PWM disabled	–
External Overtemperature Warning/Fault Limits	85/100	°C
External Overtemperature Fault Response	Retry every 350 ms	–
FAULT	Asserts low for the following faults: V _{OUT} UV or OV, V _{IN} OV, external or internal OT, TON_MAX, or output short cycle	–
ALERT Masking	Masked for loss of PLL lock and external fault inputs	–

¹ Can be changed with external configuration resistors.

PMBUS SERIAL INTERFACE

The LTC3888 has a PMBus compliant serial interface that can operate at any frequency between 10 kHz and 400 kHz. The LTC3888 is a bus slave device that communicates bidirectionally with a host (master) using standard PMBus protocols. The [Figure 3](#) found earlier in this document, along with related [Table 2](#) entries, define the timing relationships of the SDA and SCL bus signals. SDA and SCL must be high when the bus is not in use. External pull-up resistors or current sources are required on these lines.

PMBus, an incremental extension of the SMBus standard, offers more robust operation than a 2-wire I²C interface. In addition to adding a protocol layer to improve interoperability and facilitate reuse, PMBus supports bus timeout recovery for system reliability, optional packet error checking (PEC) to ensure data integrity, and peripheral hardware alerts for system fault management. In general, a programmable device capable of functioning as an I²C bus

master can be configured for PMBus management with little or no change to hardware. However, not all I²C controllers support repeat start (restart) required for PMBus reads.

For a description of the minor extensions and exceptions PMBus makes to the SMBus standard, refer to PMBus Specification Part I Revision 1.2 Paragraph 5 on Transport.

For a description of the differences between SMBus and I²C, refer to System Management Bus (SMBus) Specification Version 2.0 Appendix B on Differences Between SMBus and I²C.

The user is encouraged to reference Part I of the latest PMBus Power System Management Protocol Specification to understand how to interface the LTC3888 to a PMBus system. This specification can be found at <http://www.pmbus.org/specs.html>.

The LTC3888 uses the following standard serial interface protocols defined in the SMBus and PMBus specifications:

THEORY OF OPERATION

- ▶ Quick Command
- ▶ Send Byte
- ▶ Write Byte
- ▶ Write Word
- ▶ Read Byte
- ▶ Read Word
- ▶ Block Read
- ▶ Block Write – Block Read Process Call
- ▶ Alert Response Address

The LTC3888 does not require PEC for Quick Command under any circumstances. The LTC3888 also supports group command protocol (GCP) as required by PMBus specification Part I, section 5.2.3. GCP is used to send commands to more than one PMBus device in one continuous transmission. It should not be used with commands that require the receiving device to respond with data, such as a STATUS_BYTE command. Refer to Part I of the PMBus specification for additional details on using GCP.

All LTC3888 message transmission types allow for packet error checking. The later section on Serial Communication Errors provides more detail on packet error checking.

Figure 39 to Figure 55 illustrate these protocols. Figure 38 provides a key to the protocol diagrams. Not all protocol elements will be present in every data packet. For instance, not all packets are required to include the packet error code. A number shown above a field in these diagrams indicates the number of bits in that field. All data transfers are initiated by the present bus master regardless of how many times data direction flow may change during the subsequent transmission. The LTC3888 never functions as a bus master.

This device includes handshaking features to ensure robust system communication. Please refer to the [PMBus Communication and Command Processing](#) section in [Applications Information](#) section for more details.

- S START CONDITION
- Sr REPEATED START CONDITION
- Rd READ (BIT VALUE OF 1)
- Wr WRITE (BIT VALUE OF 0)
- A ACKNOWLEDGE (BIT SHOULD BE 0), OR
- NA NOT ACKNOWLEDGE (BIT SHOULD BE 1)
- P STOP CONDITION
- PEC PACKET ERROR CODE
- ◻ MASTER TO SLAVE
- ◼ SLAVE TO MASTER
- ... CONTINUATION OF PROTOCOL

Figure 38. PMBus Packet Protocol Diagram Element Key

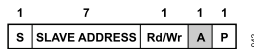

Figure 39. Quick Command Protocol

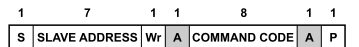

Figure 40. Send Byte Protocol

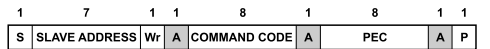

Figure 41. Send Byte Protocol with PEC

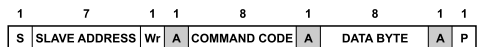

Figure 42. Write Byte Protocol

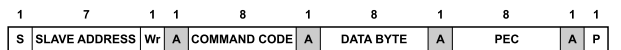

Figure 43. Write Byte Protocol with PEC

THEORY OF OPERATION

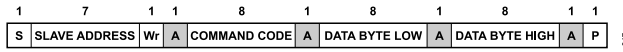

Figure 44. Write Word Protocol

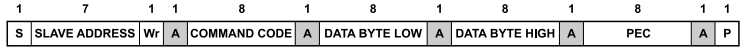

Figure 45. Write Word Protocol with PEC

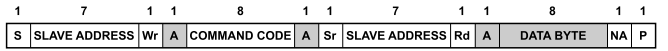

Figure 46. Read Byte Protocol

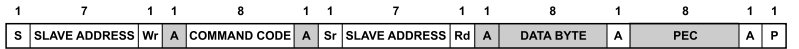

Figure 47. Read Byte Protocol with PEC

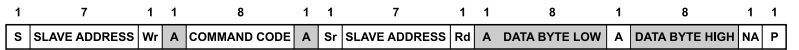

Figure 48. Read Word Protocol

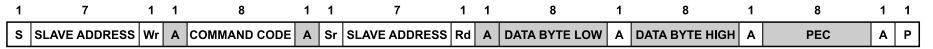

Figure 49. Read Word Protocol with PEC



Figure 50. Block Read Protocol

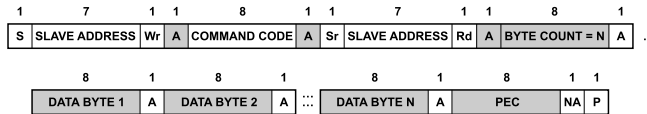

Figure 51. Block Read Protocol with PEC

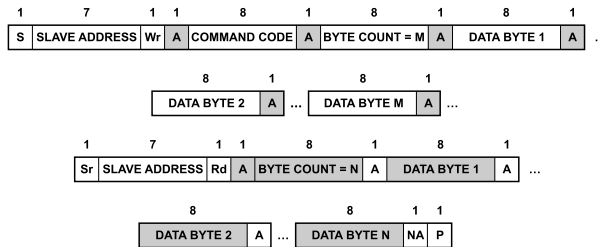

Figure 52. Block Write – Block Read Process Call

THEORY OF OPERATION

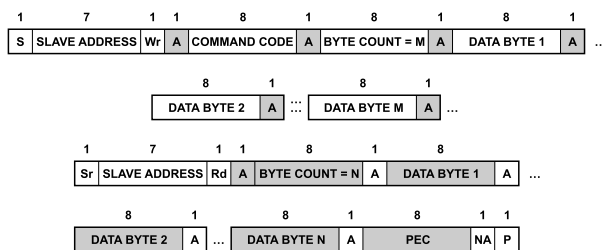

Figure 53. Block Write – Block Read Process Call with PEC

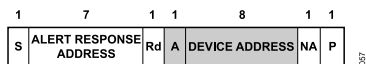

Figure 54. Alert Response Address Protocol

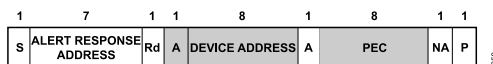

Figure 55. Alert Response Address Protocol with PEC

PMBus Serial Bus Addressing

The LTC3888 supports four types of serial bus addressing:

- ▶ Global Bus Addressing
- ▶ Power Rail Addressing
- ▶ Individual Device Addressing
- ▶ Page+ Master Channel Addressing

Global addressing provides a means for the bus master to communicate with all LTC3888 devices on the bus simultaneously. The LTC3888 global addresses of 0x5A and 0x5B cannot be changed or disabled. Commands sent to address 0x5A are applied to both master channels as if the PAGE command were set to 0xFF. Global address 0x5B is paged, allowing channel-specific control of all LTC3888 devices on the bus. Other ADI device types may respond at one or both of these global addresses. Reading from global addresses is strongly discouraged.

Rail addressing provides a means for the bus master to simultaneously communicate with all master channels connected together to produce a single output voltage (PolyPhase). While similar to global addressing, the rail address can be dynamically assigned with the paged MFR_RAIL_ADDRESS command, allowing for any logical grouping of channels that might be required for reliable system control. Reading from rail addresses is also strongly discouraged.

Device addressing is the most common means used by a bus master to communicate with an LTC3888. The value of the device address is set by the combination of ASELO/ASEL1 pin programming and the MFR_ADDRESS command. Refer to the previous section on Resistor Configuration Pins for details.

Direct, individual channel addressing (Page+) allows the bus master to communicate directly with a specific LTC3888 PWM mas-

ter channel without first using a PAGE command. Refer to the PAGE_PLUS commands for additional details.

Use of any of the four types of addressing requires careful planning to avoid address-related bus conflicts. Communication to LTC3888 devices at global and rail addresses should be limited to command write operations.

PMBus Serial Bus Timeout

The LTC3888 implements a timeout feature to avoid hanging the serial interface. The data packet timer begins running at the first START event before the SLAVE ADDRESS write byte and ends with the STOP bit. Packet transmission must be completed before the timer expires, or the LTC3888 will tri-state the bus and ignore all message data. The data packet includes the SLAVE ADDRESS byte, COMMAND CODE byte, repeated START and SLAVE ADDRESS byte (if a read operation), all ACKNOWLEDGE and flow control bits ($\overline{R}/\overline{W}$) and all data bytes.

The packet timer is typically set to 30 ms. If bit 3 of MFR_CONFIG_ALL is set, this period is extended to 255 ms. The LTC3888 automatically allows a packet transmission time of 255 ms for MFR_FAULT_LOG block reads regardless of the setting of this bit. In no circumstances will the timeout period be less than the t_{TIMEOUT} specification (25 ms minimum).

The LTC3888 supports a PMBus frequency range of 10 kHz to 400 kHz.

PMBus Communication Errors

The LTC3888 supports the optional PMBus packet error checking protocol. This protocol appends a packet error code (PEC) to the end of applicable message transfers to improve communication reliability. The PEC is a CRC-8 error-checking byte calculated

THEORY OF OPERATION

by the bus device sending the last data byte. Refer to SMBus specification 1.2 or higher for additional implementation details. All LTC3888 read operations will return a valid PEC if the bus master requests it. If bit 2 in the MFR_CONFIG_ALL command is set, the IC will not act in response to a bus write operation unless a valid PEC is also received from the host.

PEC errors on command writes, attempts to access unsupported commands, or writing invalid data to supported commands all cause the LTC3888 to generate a CML fault. The CML bit is then set in the STATUS_BYTE and STATUS_WORD commands, and the appropriate bit is set in the STATUS_CML command.

SERIAL PERIPHERAL INTERFACE (LTC3888 ONLY)

The LTC3888 also features a SPI for V_{OUT} offset adjustment. The interface can operate at any frequency up to 20 MHz. The LTC3888 is a SPI slave device that communicates unidirectionally with a host (master) using a byte-wide SPI Mode 1 protocol (SCK active high, data loads MSB to LSB on falling SCK edge). The interface chip select (\overline{SCS}) must be de-asserted between each 8-bit packet. The [SPI Timing Diagram](#) found earlier in this document, along with related [Table 2](#) entries, define the timing relationships of the SPI input signals.

The LTC3888 does not provide a conventional serial data output (aka MISO) data line to return to the SPI master. Instead, an open-drain \overline{SERR} status output is provided that can be read by a processor GPIO to detect errors in SPI data transfer. \overline{SERR} is asserted when \overline{SCS} is de-asserted if a parity error is detected or the data packet did not include exactly eight bits. \overline{SERR} would then stay low until the next falling edge of \overline{SCS} .

The 8-bit data packet sign-magnitude payload for V_{OUT} offset adjustment is shown in [Figure 56](#).

LTC3888 8-BIT SPI DATA PACKET FORMAT							
MSB	PAYLOAD						LSB
CHANNEL	SIGN	MAGNITUDE					ODD PARITY
CHAN	SIGN	B4	B3	B2	B1	B0	PAR

SIGN:

1'b0: POSITIVE V_{OUT} TWEAK

1'b1: NEGATIVE V_{OUT} TWEAK

NOTE: MFR_SPL_DATA RETURNS TWO'S-COMPLIMENT

059

Figure 56. LTC3888 SPI Packet Format

Application of this data is controlled by PMBus command parameters. V_{OUT} adjustment amplitude can be either 5 mV or 10 mV per

SPI LSB, controlled by bit 2 of MFR_PWM_MODE_LTC3888. The SPI also supports two input logic thresholds controlled by bit 5 of MFR_PWM_CONFIG_LTC3888. The interface is compatible with either SMBus or 1.8 V CMOS logic levels.

The LTC3888 SPI is also fully integrated with PMBus output voltage control. The offset adjustment set for each master channel is applied to programmed $V_{OUT_COMMAND}$ and $_MARGIN$ levels. If enabled, V_{OUT} servo control adjusts the target output voltage for each voltage loop, including margin values, according to any programmed SPI offset. If bit 4 of MFR_PWM_MODE_LTC3888 is set on either page, any valid SPI write will be applied to V_{OUT} regardless of the packet CHAN selection bit. The SPI LSB size programmed for the enabled master channel then applies to the packet data. Any existing offset is cleared when the rail is commanded off by RUN pin or OPERATION command, if MFR_RESET or RESTORE_USER_ALL is executed, or any time \overline{IC} power is initially applied or cycled.

MFR_SPI_DATA returns the present SPI control value for each page to the PMBus host using binary two's complement format.

In order to ensure these PMBus-related features function properly, the SPI master should not write to the interface more than once every 4 μ s.

An important aspect of SPI-based V_{OUT} offset on the LTC3888 is managing output voltage supervisors. As can be seen in [Figure 57](#), two options are supported by MFR_PWM_MODE_LTC3888. The first applies the programmed supervisor fault limits in a conventional, absolute fashion. The second option applies the offset programmed by the SPI to the supervisor thresholds as well, always keeping the output bracketed by these limits. The best approach for supervisor management will depend on specific application requirements.

[Figure 57](#) also includes a block diagram of V_{OUT} servo operation, showing how it interacts with the SPI output offset value and output voltage fault level supervisors.

Output voltage warning levels are not affected by these fault-related PWM mode settings or any particular SPI offset value. When using the SPI to adjust V_{OUT} , these warnings levels should be programmed to avoid any false indications due only to intended, in-range output movement.

THEORY OF OPERATION

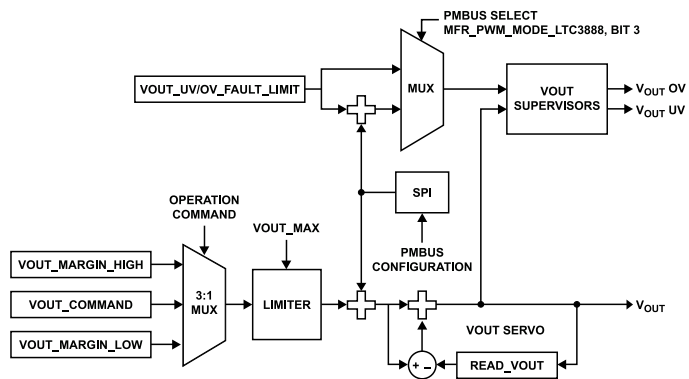

Figure 57. V_{OUT} Control Flow with Supervisors and Servo (LTC3888 Only)

PMBUS COMMAND SUMMARY

PMBUS COMMANDS

Table 11 lists supported PMBus commands and manufacturer specific commands. Additional information about these commands can be found in Revision 1.2 of Part II of the PMBus Power System Management Protocol Specification. Users are encouraged to reference that manual. Exceptions or manufacturer-specific implementations are detailed in the tables below. All standard PMBus commands from 0x00 through 0xCF not listed in this table are implicitly not supported by the LTC3888. All commands from 0xD0 through 0xFF not listed in Table 11 are implicitly reserved by the manufacturer. The LTC3888 may execute additional commands not listed in this table, and these can change without notice. Reading these unlisted commands is harmless to the operation of the IC. Writes to any unsupported or reserved command should be avoided, as that may result in a CML fault and/or undesired operation of the part.

If PMBus commands are received faster than they are being processed, the part may become too busy to handle new commands. In these cases the LTC3888 follows the protocols defined in the

PMBus Specification V1.2, Part II, Section 10.8.7, to communicate that it is busy. This device includes handshaking features to eliminate busy responses, simplify error handling software and ensure robust communication and system behavior. Please refer to [PMBus Communication and Command Processing](#) section in the [Applications Information](#) section for further details.

ADI has made an effort to establish PMBus command compatibility and functional uniformity among its family of parts. However, differences may occur due to specific product requirements. Compatibility of PMBus commands among any ICs should not be assumed based simply on command name. Always refer to the manufacturer's data sheet of each device for a complete definition of a command function.

DATA FORMATS

PMBus supports specific floating point number formats and allows for a wide range of other data formats.

Table 10 describes the data formats used by the LTC3888. Abbreviations of these formats appear throughout this document.

Table 10. Abbreviations of Supported Data Formats

PMBus					
	TERMINOLOGY	SPECIFICATION REFERENCE	ADI TERMINOLOGY	DEFINITION	EXAMPLE
L11	Linear	Part II ¶7.1	Linear_5s_11s	Floating point 16-bit data: value = $Y \cdot 2^N$, where N = b[15:11] and Y = b[10:0], both two's complement binary integers.	b[15:0] = 0x8039 = 10000_000_0011_1001 = $57 \cdot 2^{-16} = 870E-6$
L16	Linear VOUT_MODE	Part II ¶8.2	Linear_16u	Floating point 16-bit data: value = $Y \cdot 2^{-12}$, where Y = b[15:0], an unsigned integer.	b[15:0] = 0x4C00 = 0100_1100_0000_0000 value = $19456 \cdot 2^{-12} = 4.75$
CF	DIRECT	Part II ¶7.2	Varies	Data with a custom format defined in the detailed PMBus command description.	Often an unsigned or two's complement integer.
Reg	Register Bits	Part II ¶10.3	Reg	Per-bit meaning defined in detailed PMBus command description.	PMBus STATUS_BYTE command.
ASC	Text Characters	Part II ¶22.2.1	ASCII	ISO/IEC 8859-1 [A05]	LTC (0x4C5443)

Table 11. PMBus Command Summary

COMMAND NAME	CMD CODE	DESCRIPTION	TYPE	PAGED	DATA FORMAT	UNITS	NVM ¹	DEFAULT VALUE
PAGE	0x00	Channel (page) presently selected for any paged command.	R/W Byte	N	Reg			0x00
OPERATION	0x01	On, off and margin control.	R/W Byte	Y	Reg		Yes	0x80
ON_OFF_CONFIG	0x02	RUN pin and PMBus on/off command configuration.	R/W Byte	Y	Reg		Yes	0x1E
CLEAR_FAULTS	0x03	Clear all set fault bits.	Send Byte	N				
PAGE_PLUS_WRITE	0x05	Write a command directly to a specified page.	W Block	N				
PAGE_PLUS_READ	0x06	Read a command directly from a specified page.	Block R/W Process	N				
WRITE_PROTECT	0x10	Protect the device against unintended PMBus modifications.	R/W Byte	N	Reg		Yes	0x00
STORE_USER_ALL	0x15	Store entire operating memory in EEPROM.	Send Byte	N				
RESTORE_USER_ALL	0x16	Restore entire operating memory from EEPROM.	Send Byte	N				
CAPABILITY	0x19	Summary of supported optional PMBus features.	R Byte	N	Reg			0xB0

PMBUS COMMAND SUMMARY

Table 11. PMBus Command Summary (Continued)

COMMAND NAME	CMD CODE	DESCRIPTION	TYPE	PAGED	DATA FORMAT	UNITS	NVM ¹	DEFAULT VALUE
SMBALERT_MASK	0x1B	Mask ALERT activity.	Block R/W	Y	Reg		Yes	see CMD details
VOUT_TRANSITION_RATE	0x27	Slew rate control for V _{OUT} command and margining. Additionally in the LTC3888-1, slew rate for soft on/off and V _{FB} for default parts.	R/W Word	Y	L11	V/ms	Yes	0.25 A A00
FREQUENCY_SWITCH	0x33	PWM frequency control.	R/W Word	N	L11	kHz	Yes	500 kHz 0xFBE8
VIN_ON	0x35	Minimum input voltage to begin power conversion.	R/W Word	N	L11	V	Yes	6.5 V 0xCB40
VIN_OFF	0x36	Decreasing input voltage at which power conversion stops.	R/W Word	N	L11	V	Yes	6.0 V 0xCB00
IOUT_CAL_GAIN	0x38	Ratio of I _{SENSE} voltage to sensed current.	R/W Word	Y	L11	mΩ	Yes	5 mΩ 0xCA80
VOUT_OV_FAULT_RESPONSE	0x41	Fault response for V _{OUT} overvoltage and power stage fault.	R Byte	Y	Reg			0x80
VOUT_UV_FAULT_RESPONSE	0x45	V _{OUT} undervoltage fault response.	R/W Byte	Y	Reg		Yes	0xB8
IOUT_OC_FAULT_LIMIT	0x46	Output overcurrent fault limit.	R/W Word	Y	L11	A	Yes	29.75 A 0xDBB8
IOUT_OC_FAULT_RESPONSE	0x47	Output overcurrent fault response.	R/W Byte	Y	Reg		Yes	0x00
IOUT_OC_WARN_LIMIT	0x4A	Output overcurrent warning limit.	R/W Word	Y	L11	A	Yes	20.0 A 0xDA80
OT_FAULT_LIMIT	0x4F	External overtemperature fault limit.	R/W Word	Y	L11	°C	Yes	100.0°C 0xEB20
OT_FAULT_RESPONSE	0x50	External overtemperature fault response.	R/W Byte	Y	Reg		Yes	0xB8
OT_WARN_LIMIT	0x51	External overtemperature warning limit.	R/W Word	Y	L11	°C	Yes	85.0°C 0xEAA8
VIN_OV_FAULT_LIMIT	0x55	V _{IN} overvoltage fault limit.	R/W Word	N	L11	V	Yes	15.5 V 0xD3E0
VIN_OV_FAULT_RESPONSE	0x56	V _{IN} overvoltage fault response.	R/W Byte	Y	Reg		Yes	0x80
VIN_UV_WARN_LIMIT	0x58	V _{IN} undervoltage warning limit.	R/W Word	N	L11	V	Yes	6.3 V 0xCB26
TON_DELAY	0x60	Delay from RUN pin or OPERATION on command to V _{OUT} ramp start.	R/W Word	Y	L11	ms	Yes	0.0 ms 0x8000
TON_RISE (LTC3888)	0x61	Time for V _{OUT} to rise from 0.0 V to final value after TON_DELAY.	R/W Word	Y	L11	ms	Yes	8.0 ms 0xD200
TON_MAX_FAULT_LIMIT	0x62	Maximum time allowed for V _{OUT} to rise above VOUT_UV_FAULT_LIMIT after TON_DELAY.	R/W Word	Y	L11	ms	Yes	10.0 ms 0xD280
TON_MAX_FAULT_RESPONSE	0x63	Fault response when TON_MAX_FAULT_LIMIT is exceeded.	R/W Byte	Y	Reg		Yes	0xB8
TOFF_DELAY	0x64	Delay from RUN pin or OPERATION off command to TOFF_FALL ramp start.	R/W Word	Y	L11	ms	Yes	0.0 ms 0x8000
TOFF_FALL (LTC3888)	0x65	Time for V _{OUT} to fall to 0.0 V after TOFF_DELAY.	R/W Word	Y	L11	ms	Yes	8.0 ms 0xD200
STATUS_BYTE	0x78	One-byte channel status summary.	R/W Byte	Y	Reg			
STATUS_WORD	0x79	Two-byte channel status summary.	R/W Word	Y	Reg			
STATUS_VOUT	0x7A	V _{OUT} fault and warning status.	R/W Byte	Y	Reg			
STATUS_IOUT	0x7B	I _{OUT} fault and warning status.	R/W Byte	Y	Reg			
STATUS_INPUT	0x7C	Input supply fault and warning status.	R/W Byte	N	Reg			

PMBUS COMMAND SUMMARY

Table 11. PMBus Command Summary (Continued)

COMMAND NAME	CMD CODE	DESCRIPTION	TYPE	PAGED	DATA FORMAT	UNITS	NVM ¹	DEFAULT VALUE
TON_MAX_FAULT_LIMIT	0x7D	External temperature fault and warning status.	R/W Byte	Y	Reg			
TON_MAX_FAULT_RESPONSE	0x7E	Communication, memory and logic fault and warning status.	R/W Byte	N	Reg			
TOFF_DELAY	0x80	IC-specific status.	R/W Byte	Y	Reg			
TOFF_FALL (LTC3888)	0x88	Measured V_{IN} .	R Word	N	L11	V		
STATUS_BYTE	0x8B	Measured V_{OUT} .	R Word	Y	L16	V		
STATUS_WORD	0x8C	Measured I_{OUT} .	R Word	Y	L11	A		
STATUS_VOUT	0x8D	Measured external temperature.	R Word	Y	L11	°C		
STATUS_IOUT	0x8E	Measured internal temperature.	R Word	N	L11	°C		
STATUS_INPUT	0x95	Measured PWM input clock frequency.	R Word	Y	L11	kHz		
TON_MAX_FAULT_LIMIT	0x98	Supported PMBus version.	R Byte	N	Reg			0x22 V1.2
MFR_ID	0x99	Manufacturer identification.	R String	N	ASC			LTC
IC_DEVICE_ID	0xAD	Model number.	R String	N	ASC			LTC3888 LTC3888-1
Commands for Digital Output Voltage Control (See Applications Information section or PMBus Command Details section for details)								
VOUT_MODE	0x20	Voltage-related format (Linear) and exponent.	R Byte	Y	Reg			0x14 2 ⁻¹²
VOUT_COMMAND	0x21	Nominal output voltage setpoint for the LTC3888/ LTC3888-2 and LTC3888-1 with VOUT_SCALE_LOOP defined. Otherwise nominal V_{FB} .	R/W Word	Y	L16	V	Yes	400 mV 0x0666
VOUT_MAX	0x24	Maximum V_{OUT} capability.	R Word	Y	L16	V		1.1 V LTC3888-1 0x119A 3.75 V LTC3888 0x3C00
VOUT_MARGIN_HIGH	0x25	Margin high voltage setpoint for the LTC3888/ LTC3888-2 and LTC3888-1 with VOUT_SCALE_LOOP defined. Otherwise margin high V_{FB} .	R/W Word	Y	L16	V	Yes	420 mV 0x06B8
VOUT_MARGIN_LOW	0x26	Margin low voltage setpoint for the LTC3888/ LTC3888-2 and LTC3888-1 with VOUT_SCALE_LOOP defined. Otherwise margin low V_{FB} .	R/W Word	Y	L16	V	Yes	380 mV 0x0614
VOUT_SCALE_LOOP (LTC3888-1)	0x29	Nominal V_{OUT}/V_{FB} gain provided by external feedback network.	R/W Word	Y	L11	V/V	Yes	N/A
VOUT_OV_FAULT_LIMIT	0x40	V_{OUT} over voltage fault limit for the LTC3888/ LTC3888-2 and LTC3888-1 with VOUT_SCALE_LOOP defined. Otherwise V_{OUT} over voltage V_{FB} .	R/W Word	Y	L16	V	Yes	440 mV 0x070A
VOUT_OV_WARN_LIMIT	0x42	V_{OUT} overvoltage warning limit, sensed at $V_{SENSE\pm}$.	R/W Word	Y	L16	V	Yes	3.6 V 0x3981
VOUT_UV_WARN_LIMIT	0x43	V_{OUT} undervoltage warning limit, sensed at $V_{SENSE\pm}$.	R/W Word	Y	L16	V	Yes	0.0 V 0x0000
VOUT_UV_FAULT_LIMIT	0x44	V_{OUT} under voltage fault limit for the LTC3888/ LTC3888-2 and LTC3888-1 with VOUT_SCALE_LOOP defined. Otherwise V_{OUT} under voltage V_{FB} .	R/W Word	Y	L16	V	Yes	360 mV 0x05C3
TOFF_MAX_WARN_LIMIT	0x66	Maximum time for V_{OUT} to reach 0.125xVOUT_COMMAND after being commanded to 0.0 V.	R/W Word	Y	L11	ms	Yes	0 ms 0x8000
LTC3888/LTC3888-1 Custom Commands								
MFR_VOUT_MAX	0xA5	Maximum VOUT_MAX.	R Word	Y	L16	V		3.75 V

PMBUS COMMAND SUMMARY

Table 11. PMBus Command Summary (Continued)

COMMAND NAME	CMD CODE	DESCRIPTION	TYPE	PAGED	DATA FORMAT	UNITS	NVM ¹	DEFAULT VALUE
								0x3C00
USER_DATA_0x	0xB0	EEPROM word reserved for LTpowerPlay.	R/W Word	N	Reg		Yes	
USER_DATA_0x	0xB1	EEPROM word reserved for LTpowerPlay.	R/W Word	Y	Reg		Yes	
USER_DATA_0x	0xB2	EEPROM word reserved for OEM use.	R/W Word	N	Reg		Yes	
USER_DATA_0x	0xB3	EEPROM word available for general data storage.	R/W Word	Y	Reg		Yes	0x0000
USER_DATA_0x	0xB4	EEPROM word available for general data storage.	R/W Word	N	Reg		Yes	0x0000
MFR_INFO	0xB6	Manufacturer-specific information	R Word	N	Reg			
MFR_EE_xxxx	0xBD	(contact the factory)						
MFR_EE_xxxx	0xBE	(contact the factory)						
MFR_EE_xxxx	0xBF	(contact the factory)						
MFR_CHAN_CONFIG	0xD0	General channel-specific configuration.	R/W Byte	Y	Reg		Yes	0x1D
MFR_CONFIG_ALL	0xD1	General device-level configuration.	R/W Byte	N	Reg		Yes	0x21
MFR_FAULT_PROPAGATE	0xD2	Configure fault propagation via $\overline{\text{FAULT}}$ pins.	R/W Word	Y	Reg		Yes	0x6993
MFR_PWM_COMP	0xD3	Channel-specific PWM loop compensation.	R/W Byte	Y	Reg		Yes	0xAE
MFR_PWM_MODE_LTC3888	0xD4	LTC3888-1 channel-specific PWM mode control.	R/W Byte	Y	Reg		Yes	0x02
MFR_FAULT_RESPONSE	0xD5	PWM response when $\overline{\text{FAULT}}$ pin is low due to external fault.	R/W Byte	Y	Reg		Yes	0xC0
MFR_OT_FAULT_RESPONSE	0xD6	Internal overtemperature fault response.	R Byte	N	Reg			0xC0
MFR_IOUT_PEAK	0xD7	Maximum master channel I _{OUT} measurement since last MFR_CLEAR_PEAKS.	R Word	Y	L11	A		
MFR_RETRY_DELAY	0xDB	Minimum time before retry after a fault.	R/W Word	Y	L11	ms	Yes	350 ms 0xFABC
MFR_RESTART_DELAY	0xDC	Minimum time RUN pin is held low by the LTC3888-1.	R/W Word	Y	L11	ms	Yes	500 ms 0xFBE8
MFR_VOUT_PEAK	0xDD	Maximum V _{OUT} measurement since last MFR_CLEAR_PEAKS.	R Word	Y	L16	V		
MFR_VIN_PEAK	0xDE	Maximum V _{IN} measurement since last MFR_CLEAR_PEAKS.	R Word	N	L11	V		
MFR_TEMPERATURE_1_PEAK	0xDF	Maximum external temperature measurement since last MFR_CLEAR_PEAKS.	R Word	Y	L11	°C		
MFR_TOTAL_IOUT	0xE1	Read total IOUT for each page/rail defined by MFR_PWM_CONFIG_LTC3888-1[2:0]	R Word	Y	L11	A		
MFR_CLEAR_PEAKS	0xE3	Clear all peak values.	Send Byte	N				
MFR_PADS_LTC3888-1	0xE5	State of selected LTC3888-1 pads.	R Word	N	Reg			
MFR_ADDRESS	0xE6	Specify right-justified 7-bit device address.	R/W Byte	N	Reg		Yes	0x4F
MFR_SPECIAL_ID	0xE7	Unique manufacturer product ID	R Word	N	Reg			0x480X (LTC3888) 0x488X (LTC3888-1)
MFR_SPI_DATA (LTC3888)	0xE8	Read SPI data as binary two's complement. (LTC38888 Only)	R Byte	Y	CF			
MFR_FAULT_LOG_STORE	0xEA	Force capture of fault log in RAM and transfer to EEPROM.	Send Byte	N				
MFR_FAULT_LOG_CLEAR	0xEC	Clear existing EEPROM fault log.	Send Byte	N				
MFR_FAULT_LOG	0xEE	Read fault log data.	R Block	N	Reg			
MFR_COMMON	0xEF	ADI-generic device status reporting.	R Byte	N	Reg			
MFR_COMPARE_USER_ALL	0xF0	Compare contents of command RAM with EEPROM.	Send Byte	N				

PMBUS COMMAND SUMMARY

Table 11. PMBus Command Summary (Continued)

COMMAND NAME	CMD CODE	DESCRIPTION	TYPE	PAGED	DATA FORMAT	UNITS	NVM ¹	DEFAULT VALUE
MFR_TEMPERATURE_2_PEAK	0xF4	Maximum internal temperature measurement since last MFR_CLEAR_PEAKS.	R Word	N	L11	°C		
MFR_PWM_CONFIG_LTC3888	0xF5	LTC3888-1 PWM configuration common to both master channels.	R/W Byte	N	Reg		Yes	0x03
MFR_LOAD_EMULATION	0xF7	Load step emulation control.	R/W Byte	Y	Reg			0x00
MFR_TEMP_1_GAIN	0xF8	Slope for external temperature calculations.	R/W Word	Y	L11	mV/ °C	Yes	8 mV/°C 0xD200
MFR_TEMP_1_OFFSET	0xF9	0°C offset for external temperature calculations.	R/W Word	Y	L11	mV	Yes	600 mV 0x0258
MFR_RAIL_ADDRESS	0xFA	Specify unique right-justified 7-bit address for channels comprising a PolyPhase output.	R/W Byte	Y	Reg		Yes	0x80
MFR_RESET	0xFD	Force full reset without removing power.	Send Byte	N				

¹ Indicates a command value stored to and restored from internal EEPROM using the STORE_USER_ALL and RESTORE_USER_ALL commands, respectively.

APPLICATIONS INFORMATION

EFFICIENCY CONSIDERATIONS

Normally, one of the primary goals of any LTC3888 application will be to obtain the highest practical conversion efficiency. The efficiency of a switching regulator is equal to the output power divided by the input power. It is often useful to analyze individual losses to determine what is limiting the efficiency and to ascertain which change would produce the most improvement. Balancing or limiting these individual losses plays a dominant role in the component selection process outlined over the next few sections.

Percent efficiency can be expressed as:

$$\% \text{Efficiency} = 100\% - (L1 + L2 + L3 + \dots)$$

where L1, L2, et al, are the individual losses as a percentage of input power: $100 \cdot P_{L_n}/P_{IN}$.

Although all dissipative elements in the system produce losses, four main sources usually account for most of the losses in LTC3888 applications: IC supply current, I^2R losses, topside power MOSFET transition losses and total gate drive current.

1. The LTC3888 IC supply current is a DC value given in the [Electrical Characteristics](#) table. The absolute loss created by the IC itself is approximately this current times the V_{IN} supply voltage. IC supply current typically results in a small loss (<0.1%).
2. I^2R losses occur mainly in the DC resistances of the selected power stage, inductor, PCB routing, and input and output capacitor ESR. It is crucial that careful attention is paid to the layout of the power path on the PCB to minimize that resistance. In a 2-phase 1.2 V system, 1 m Ω of PCB resistance at the output costs 5% in efficiency with the output running at 60 A.
3. Transition losses apply only to the selected power stage and normally do not become significant until operating above 12 V.
4. Gate drive current is equal to the sum of the top and bottom MOSFET gate charges multiplied by the frequency of operation. These charges are based on internal power stage design and are normally included in overall efficiency (or power loss) numbers provided by the manufacturer at a given operating condition.

Other sources of loss include internal body or external Schottky diode conduction during the power stage FET driver non-overlap time, as well as inductor core losses. These latter categories generally account for less than 2% total additional loss.

POWER STAGE SELECTION AND INTERFACE

The LTC3888 operates with power stages that provide a voltage or current monitor of the output current they sense. As a minimum, these stages must also accept 3.3 V-compatible three-state PWM input control. Other features such as PWM input off-state biasing, power stage temperature monitoring, fault detection and indication, and UVLO protection are optional. Examples of these kinds of devices include the [LTC7051](#), IR35411 and FDMF3170.

The LTC3888 I_{SENSE} pins are high impedance inputs to internal interface circuits and the monitor ADC, both using a common mode of IREF (1.6 V). Maximum instantaneous differential current sense input relative to IREF is 525 mV, and maximum DC input differential is 400 mV. These inputs must be properly connected in the application at all times. While not strictly required, it is recommended to short I_{SENSE} to IREF on PWM channels disabled by MFR_PWM_CONFIG_LTC3888 master/slave setting.

As shown in [Figure 58](#) and [Figure 59](#), the LTC3888 is designed to interface to power stages that provide either a current or voltage analog of sensed output current. The LTC3888 IREF output should be used to provide the common mode voltage for this output current monitor, with some bypass located adjacent to each power stage and returned to GND (IC paddle). The LTC3888 is designed to work best when the power stage output current monitor is scaled to provide between 3 mV/A and 10 mV/A to its I_{SENSE} input. This scaling must be identical for all phases on a rail. For most power stages providing a voltage-mode monitor, no additional external scaling components are required.

Some of these power stages require the controller to provide a PWM pulse with a minimum width. The LTC3888 can be configured to accommodate this requirement by setting bit 1 of MFR_PWM_MODE_LTC3888.

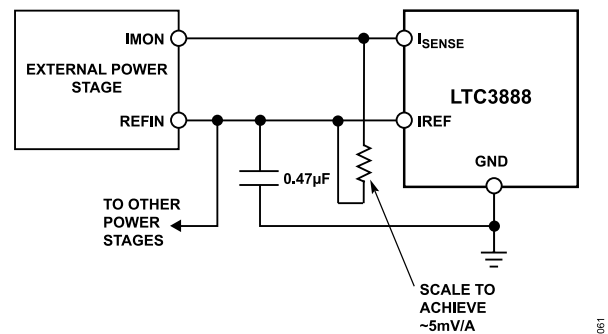

Figure 58. Interface to Current-Mode Output Current Sense

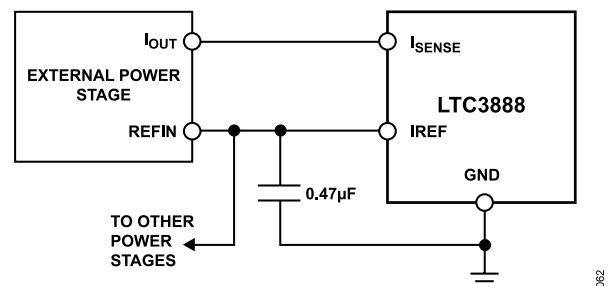

Figure 59. Interface to Voltage-Mode Output Current Sense

The LTC3888 TSNS pins interface directly to the wire-OR shared TEMP/FAULT bus found on most power stages offering output current monitor. When all phases are fault-free, the voltage on this bus indicates the highest power stage temperature on the rail. The internal monitor ADC converts this voltage, and the computed tem-

APPLICATIONS INFORMATION

perature value is returned by the paged READ_TEMPERATURE_1 telemetry command. The slope of the external temperature sensor can be modified to fit the selected power stage using the coefficient stored in MFR_TEMP_1_GAIN. The offset of the external temperature sense can be adjusted by MFR_TEMP_1_OFFSET, which designates the bus voltage indicating 0°C.

The LTC3888 also recognizes indicated power stage fault conditions on the shared TEMP/FAULT bus. This includes support for

optional power stage UV indication when enabled with bit 0 of MFR_PWM_MODE_LTC3888. These events are reported through standard PMBus status registers for improved system state observation by the bus host as shown in Table 12. Refer to previous Theory of Operation section discussions on [Hardwired PWM Response to Power Stage Faults](#) section and [Status Registers and ALERT Masking](#) section for additional details.

Table 12. Special LTC3888 Status Indications

CONDITION INDICATED ¹	PAGED			MFR_PADS_LTC3888 ²
	STATUS_VOUT BIT 7 (VOUT_OV FAULT)	STATUS_VOUT BIT 4 (VOUT_UV FAULT)	STATUS_IOUT BIT 3	CH0/1 DrMOS READY BIT 14/15
V _{OUT} OV	Yes			Yes
V _{OUT} UV		Yes		Yes
V _{SENSE+} OPEN ^{3, 4}	Yes	Yes		Yes
Power Stage UV (TSNS) ⁵ or VDR Monitor UV	Yes (IFF CH Set to Run)			
Power Stage Fault ⁶	Yes		Yes	Yes

¹ With the exception of V_{SENSE+} Open, all VOUT_OV Fault conditions are handled by VOUT_OV_FAULT_RESPONSE, which is immediate off with no retry, and a VOUT_UV fault condition is handled by VOUT_UV_FAULT_RESPONSE.

² MFR_PADS_LTC3888[15:14] respond to enabled power stage UV detection by indicating NOT READY (1'b0) for their respective channels, regardless of PWM run state. Otherwise these bits indicate READY (1'b1).

³ Both V_{SENSE+} lines are tested each time the LTC3888 powers up or resets. The response of the LTC3888 for any open V_{SENSE+} line is to disable all outputs. A detected open line condition can only be cleared with successful retesting by power cycle or MFR_RESET.

⁴ Both bit 7 and bit 4 of STATUS_VOUT may also be set if a power stage UV or fault occurs during a true V_{OUT} UV with the PWM still running. In this case STATUS_IOUT and MFR_PADS will continue to accurately indicate power stage state, which does not require a full reset to clear.

⁵ Detection of this condition must be enabled by setting bit 0 of MFR_PWM_MODE_LTC3888 (paged). No UV indication is given or response taken if bit 0 of MFR_PWM_MODE_LTC3888 is clear.

⁶ The exact nature of fault indicated in this case varies by manufacturer and can include such issues as gross output overcurrent or power stage overtemperature.

APPLICATIONS INFORMATION

If power stage UV detection is enabled, a check of the MFR_PADS_LTC3888 status bits shown in Table 12 is strongly recommended before turning on a rail. Otherwise, if the power stage UV is in the process of clearing during system power-up, the resulting LTC3888 fault condition cannot be distinguished from overvoltage on the output.

USING THE VDR MONITOR

When a shared TEMP/FAULT bus is not provided from the power stages in an application, or if a necessary UV indication is not provided by the particular power stage selected, pin 8 of the LTC3888 can be programmed to function as a VDR_MON input by bit 5 of MFR_CHAN_CONFIG on Page 0 to observe UV conditions on the power stage gate drive supply. As shown in Figure 60 this simply requires sensing the supply to be monitored with a resistor divider that produces 1.22 V at the desired UV threshold.

$$V_{UV} = 1.22 \text{ V} \cdot (R1 + R2)/R2$$

A single VDR_MON input is provided for both master channels. The state of bit 0 of MFR_PWM_CONFIG_LTC3888 is ignored and UV detection on TSNS1 fully disabled when VDR_MON is active.

UNUSED TSNS INPUTS

In cases where a shared TEMP/FAULT bus is not available or monitoring of external temperature is simply not required, unused

TSNS inputs may be left open or wired to GND as long as bit 0 of MFR_PWM_MODE_LTC3888 (paged) is left clear. The LTC3888 will then continue to respond to READ_TEMPERATURE_1 requests, but the data returned will be meaningless.

PWM FREQUENCY AND INDUCTOR SELECTION

The selection of the PWM switching frequency is a trade-off between efficiency, transient response and component size. High frequency operation reduces the size of the inductor and output capacitor as well as increasing the maximum practical control loop bandwidth. However, efficiency is generally lower due to increased transition and switching losses. The inductor value is related to the switching frequency f_{PWM} and step-down ratio. It should be selected to meet choke ripple current requirements. The inductor value can be calculated using the following equation:

$$L = \left(\frac{V_{OUT}}{f_{PWM} \times \Delta I_L} \right) \times \left(1 - \frac{V_{OUT}}{V_{IN}} \right)$$

Allowing a larger value of choke ripple current (ΔI_L) leads to smaller L, but results in greater core loss and higher output voltage ripple for a given output capacitance and/or ESR. A reasonable starting point for setting the ripple current is 30% of the maximum output current.

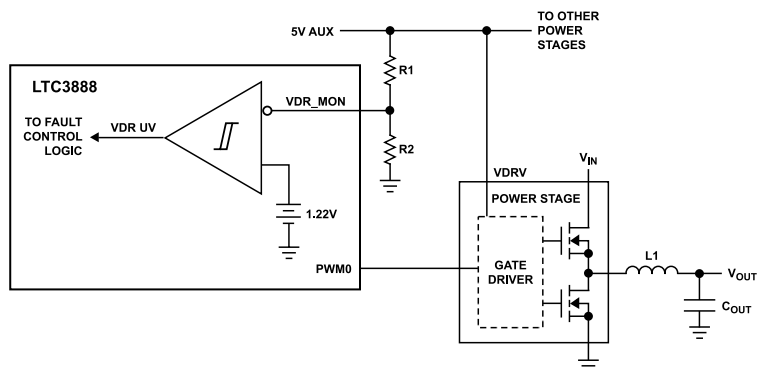

Figure 60. LTC3888 Power Stage VDR Monitor

APPLICATIONS INFORMATION

The inductor saturation current rating needs to be higher than the peak inductor current during transient conditions. If I_{OUT} is the maximum rated load current, then the maximum transient current I_{MAX} would normally be chosen to be some factor greater than I_{OUT} (e.g., $1.6 \cdot I_{OUT}$).

The minimum saturation current rating should be chosen to allow margin due to manufacturing and temperature variation in the power stage output current monitor. A reasonable I_{SAT} value would be $2.2 \cdot I_{OUT}$.

The programmed current limit `IOUT_OC_FAULT_LIMIT` must be low enough to ensure that the inductor never saturates and high enough to allow increased current during transient conditions. For example, if:

$$I_{SAT} = 2.2 \cdot I_{OUT}, \text{ and}$$

$$I_{MAX} = 1.6 \cdot I_{OUT}$$

a reasonable output current limit would be

$$\text{IOUT_OC_FAULT_LIMIT} = 1.8 \cdot I_{OUT}$$

Once the value of L is known, the type of inductor must be selected. High efficiency converters generally cannot afford the core losses found in low-cost powdered iron cores, forcing the use of more expensive ferrite or molypermalloy cores. Also, core losses decrease as inductance increases. Unfortunately, increased inductance requires more turns of wire, larger inductance and larger copper losses.

Ferrite designs have very low core loss and are preferred at high switching frequencies. However, these core materials exhibit hard saturation, causing an abrupt reduction in the inductance when the peak current capability is exceeded. Do not allow the core to saturate.

C_{IN} SELECTION

The input bypass capacitance for an LTC3888 power circuit needs to have ESR low enough to keep the supply drop low as the top MOSFETs turn on, RMS current capability adequate to withstand the ripple current at the input, and a capacitance value large enough to maintain the input voltage until the input supply can make up the difference. Generally, a capacitor that meets the first two requirements (particularly a non-ceramic type) will have far more capacitance than is required to keep capacitance-based droop under control.

The input capacitance voltage rating should be at least 1.4 times the maximum input voltage. Power loss due to ESR occurs as I^2R dissipation in the capacitor itself. The input capacitor RMS current and its impact on any preceding input network is reduced by PolyPhase architecture. It can be shown that the worst case RMS current occurs when only one phase is operating. The phase with the highest $(V_{OUT})(I_{OUT})$ product should be used to determine the maximum RMS current requirement. Increasing the number of phases will decrease the input RMS ripple current from this maxi-

imum value. 2-phase operation typically reduces the input capacitor RMS ripple current by a factor of 30% to 70%.

In continuous inductor conduction mode, the source current of the top power MOSFET is approximately a square wave of duty cycle V_{OUT}/V_{IN} . The maximum RMS capacitor current in this case is given by:

$$I_{RMS} \approx I_{OUT(MAX)} \frac{\sqrt{V_{OUT}(V_{IN} - V_{OUT})}}{V_{IN}}$$

This formula has a maximum at $V_{IN} = 2V_{OUT}$, where

$$I_{RMS} = I_{OUT}/2$$

This simple worst-case condition is commonly used for design because even significant deviations do not offer much relief.

Note that manufacturer ripple current ratings for capacitors are often based on only 2000 hours of life. This makes it advisable to further derate the capacitor or to choose a capacitor rated at a higher temperature than required. Several capacitors may also be paralleled to meet size or height requirements in the design. Always consult the manufacturer if there is any question.

Ceramic, tantalum, semiconductor electrolyte (OS-CON), hybrid conductive polymer (SUNCON) and switcher-rated electrolytic capacitors can be used as input capacitors, but each has drawbacks. Ceramics have high voltage coefficients of capacitance and may have audible piezoelectric effects; tantalums need to be surge-rated; OS-CONs suffer from higher inductance, larger case size and limited surface mount applicability; and electrolytic capacitors have higher ESR and can dry out. Sanyo OS-CON SVP(D) series, Sanyo POSCAP TQC series, or Panasonic EE-FT series aluminum electrolytic capacitors can be used in parallel with high performance ceramic capacitors as an effective means of achieving low ESR and high bulk capacitance.

In addition to PWM bulk input capacitance, a small (0.01 μF to 1 μF) bypass capacitor between the chip V_{IN} pin and ground, placed close to the LTC3888, is also suggested. A small resistor placed between the bulk C_{IN} and the V_{IN} pin/bypass provides further isolation between rails. However, if the time constant of any such R-C network on the V_{IN} pin exceeds 30 ns, dynamic line transient response can be adversely affected.

C_{OUT} SELECTION

The selection of C_{OUT} is primarily determined by the ESR required to minimize voltage ripple and load step transients. The output ripple ΔV_{OUT} is approximately bounded by:

$$\Delta V_{OUT} \leq \Delta I_L \left(ESR + \frac{1}{8 \times f_{PWM} \times C_{OUT}} \right)$$

where ΔI_L is the inductor ripple current.

$$\Delta I_L = \frac{V_{OUT}}{L \times f_{PWM}} \left(1 - \frac{V_{OUT}}{V_{IN}} \right)$$

APPLICATIONS INFORMATION

Since ΔI_L increases with input voltage, the output ripple voltage is highest at maximum input voltage. Typically once the ESR requirement is satisfied, the capacitance is adequate for filtering and has the necessary RMS current rating.

Manufacturers such as Sanyo, Panasonic and Cornell Dubilier should be considered for high performance through-hole capacitors. The OS-CON semiconductor electrolyte capacitor available from Sanyo has a good (ESR)(size) product. Additional ceramic capacitors in parallel with polarized capacitors is recommended to offset the effect of lead inductance.

In surface mount applications, multiple capacitors may have to be paralleled to meet the ESR or transient current handling requirements of the application. Aluminum electrolytic and dry tantalum capacitors are both available in surface mount configurations. New polymer surface mount capacitors also offer very low ESR but have much lower capacitive density. In the case of tantalum, it is critical that the capacitors are surge tested for use in switching power supplies. Several excellent output capacitor choices include the Sanyo POSCAP TPD/E/F series, the Kemet T520, T530 and A700 series, NEC/Tokin NeoCapacitors and Panasonic SP series. Other suitable capacitor types include Nichicon PL series and Sprague 595D series. Consult the manufacturer for other specific recommendations.

PROGRAMMABLE LOOP COMPENSATION

Because the LTC3888 uses an OTA error amplifier architecture, Type II compensation is most commonly applied for stabilizing the voltage control loop as shown in Figure 61. The LTC3888 offers programmable loop compensation to optimize the transient response without requiring a hardware change. Internal error amplifier g_m can be varied from 1 mmho to 5.73 mmho, and internal compensation resistor R_{ITH} can be varied from 1 k Ω to 62 k Ω with the MFR_PWM_COMP command. A maximum of two external capacitors are then required to stabilize each voltage control loop.

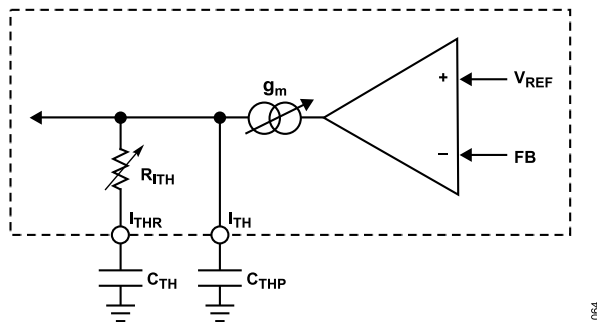

Figure 61. Programmable Loop Compensation

By adjusting EA g_m and R_{ITH} the LTC3888 can provide flexible Type II compensation for loop optimization over a wide range of output capacitance. Adjusting g_m will change compensation gain over the entire frequency range without adjusting any pole-zero locations as shown in Figure 62.

Adjusting R_{ITH} will change the pole-zero locations as shown in Figure 63. LTpowerCAD is a freeware tool available from ADI suitable for determining optimum values for g_m and R_{ITH} for the LTC3888.

Internal R_{ITH} and external C_{TH} combine to set the dominant pole-zero loop compensation. Adjust the value of R_{ITH} to optimize transient response after final PCB layout is complete and a particular C_{TH} and output filter capacitor have been selected. The types and values used for these capacitors will strongly influence loop gain and phase.

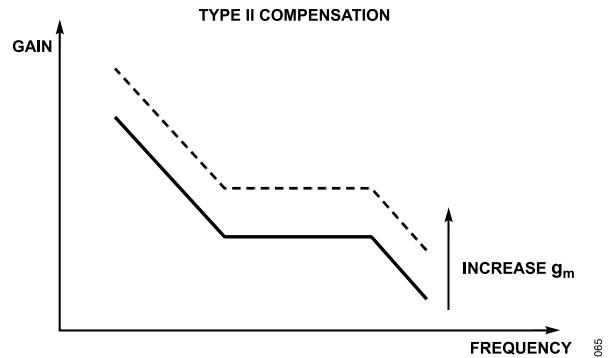

Figure 62. Error AMP g_m Adjust

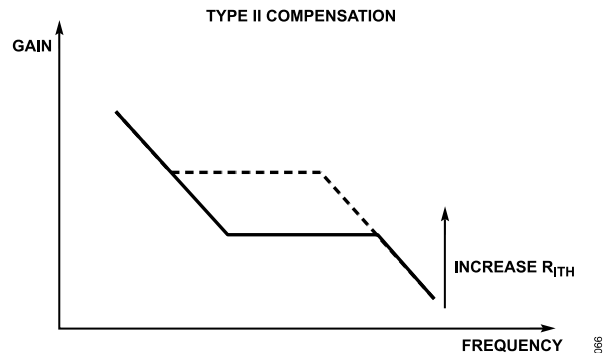

Figure 63. R_{ITH} Adjust

Occasionally, fine tuning of AC compensation to optimize transient response may benefit from additional mid-band phase recovery. In this case, another pole-zero pair can be added to the feedback loop of the LTC3888-1/LTC3888-2 with a small capacitor or R-C across the top resistor of the V_{OUT} feedback network, as shown in Figure 64. Often R_3 is replaced with a short when the error amplifier is an OTA, as is the case with the LTC3888-1/LTC3888-2. Adding R_3 provides additional AC gain control, if needed. This allows total loop compensation approaches similar to a Type III network. The LTC3888-2 does not require the resistor divider shown in Figure 64.

APPLICATIONS INFORMATION

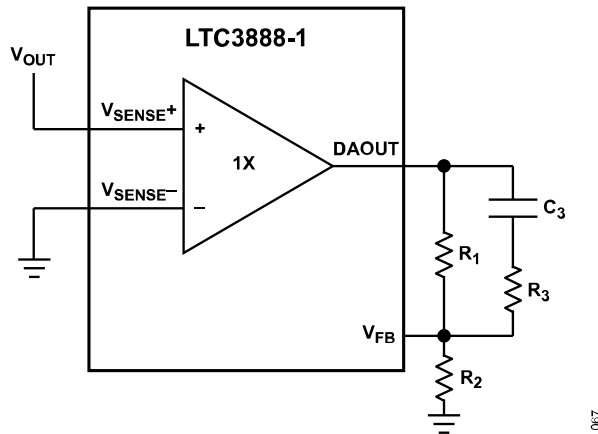

Figure 64. Remote Sense and Setting Output Voltage (LTC3888-1)

Regulator loop stability can be checked by observing a load transient response. Post-transient output voltage settling is related to closed-loop stability and will demonstrate actual overall supply performance. Switching regulators can require several clock cycles to respond to a direct step in DC load current due to the time required for a voltage feedback error signal to develop. As the loop responds and adjusts to remove the developing error signal, V_{OUT} can be monitored for an over-damped, sluggish response or excessive overshoot or ringing, which would then indicate a stability problem.

The LTC3888 features flexible load step emulation (PMBus MFR_LOAD_EMULATION command) to simulate calibrated output loads placed simultaneously on all phases of the rail. It is not necessary to generate an actual, high powered and regulated load step on the rail output. This creates a V_{OUT} response that is identical to that of a physical output load step with C_{OUT} ESR effects removed from the initial step edge. This makes observation of V_{OUT} useful for loop evaluation. In a predominantly second-order system, phase margin and/or damping factor can be estimated using the percentage of overshoot seen at the output. Bandwidth can also be estimated by the rise time of the V_{OUT} waveform in this case.

A more severe load step case is created if underpowered loads with large supply bypass capacitors ($>1 \mu\text{F}$) are cold-switched to the rail output for power. The discharged bypass capacitors are effectively put in parallel with C_{OUT} , causing a rapid drop in V_{OUT} . No regulator can alter power delivery quickly enough to prevent this sudden step change in output voltage if the load switch resistance is low and driven on quickly. If the ratio of such a switched C_{LOAD} to C_{OUT} is greater than 1:50, the switch rise time should be limited to approximately $25 \cdot C_{LOAD}$. As an example, a $10 \mu\text{F}$ switched load would require a $250 \mu\text{s}$ rise time with charging current limited to about 200 mA.

PCB LAYOUT CONSIDERATIONS

To prevent magnetic and electrical field radiation, or high frequency resonant problems, and to ensure correct IC operation, proper layout of the components connected to the LTC3888 is essential.

Refer to Figure 65, which also illustrates current waveforms typically present in the circuit branches. In this drawing SW0/1 and D0/1 represent salient features of the selected power stage. For maximum efficiency, the switch node (input to L0/1) rise and fall times should be minimized. The following PCB design priority list will help ensure proper topology.

1. Place a ground or DC voltage layer between a power layer and a small-signal layer. Generally, power planes should be placed on the top layer (4-layer PCB), or top and bottom layer if more than 4 layers are used. Use wide/short copper traces for power components and avoid improper use of thermal relief around power plane vias to minimize resistance and inductance.
2. Low ESR input capacitors should be placed as close as possible to the power stage FET supply and ground connections with the shortest copper traces possible. The power stage must be on the same layer of copper as the input capacitors with a common topside power connection at C_{IN} . Do not attempt to split the input decoupling for multiple phases, as a large resonant loop can result. Vias should not be used to make these connections. Avoid blocking forced air flow to the power stages with large size passive components.
3. Place the inductor input as close as possible to the power stage. Minimize the surface area of the switch node. Make the trace width the minimum needed to support the maximum output current. Avoid copper fills or pours. Avoid running the connection on multiple copper layers in parallel. Minimize capacitance from the switch node to any other trace or plane.
4. PCB traces for remote voltage sense should be run together back to the LTC3888 in pairs with the smallest spacing possible on any given layer on which they are routed. Avoid high frequency switching signals and ideally shield with ground planes. Locate any filter component on these traces next to the LTC3888, and not at the Kelvin sense location.
5. PCB traces for output current sense (I_{SENSE} , I_{REF}) should avoid high frequency switching signals and ideally be shielded with ground planes. Filter components on these traces should return to GND (IC paddle) and not to a local PGND.
6. Place low ESR output capacitors adjacent to the inductor output and ground. Output capacitor ground connections must feed into the same copper that connects to the input capacitor ground before connecting back to system ground.
7. Connection of switching ground to system ground, small-signal analog ground or any internal ground plane should be single-point. If the system has an internal system ground plane, a good way to do this is to cluster vias into a single star point to make the connection. This cluster should be located directly beneath the IC GND paddle, which serves as analog signal ground. A useful CAD technique is to make separate ground nets and use a 0Ω resistor to connect them to system ground.
8. Place all small-signal components away from high frequency switching nodes. Place decoupling capacitors for the LTC3888 immediately adjacent to the IC.

APPLICATIONS INFORMATION

9. A good rule of thumb for via count in a given high current path is to use 0.5 A per via. Be consistent when applying this rule.
10. Copper fills or pours are good for all power connections except as noted above in rule 3. Copper planes on multiple layers can also be used in parallel. This helps with thermal management and lowers trace inductance, which further improves EMI performance.

OUTPUT VOLTAGE SENSING

Accurate Kelvin sensing techniques should be used to connect the output voltage differentially back to the LTC3888 $V_{SENSE\pm}$ pins of the master channel for best output voltage regulation at the point of load. These pins also provide the ADC inputs for output voltage telemetry. These connections are not strictly required for disabled master channels (i.e. forced to be slave phases using bit 4 of `MFR_PWM_MODE_LTC3888`, with an external I_{TH} connection). However, because the LTC3888 error amplifier is an OTA, it is sometimes advantageous to wire-OR I_{TH} pins and use multiple V_{OUT} sense points to provide improved power plane voltage aver-

aging. Post-manufacture selection of the most ideal load sense point via final EEPROM programming is also possible. So in general, sound Kelvin V_{OUT} sensing techniques for all LTC3888 master channels is recommended. Refer to [Figure 64](#).

CLASSICAL ANALOG OUTPUT VOLTAGE CONTROL (LTC3888-1)

The LTC3888-1 employs a classical analog approach for setting output voltage when using default factory EEPROM values. This control uses the circuit of [Figure 65](#), where external resistors R1 and R2 are used to set V_{OUT} according to the following equation.

$$V_{OUT} = (R1 + R2)/R2 \times 400 \text{ mV}$$

In this mode, output margining is still possible using the `OPERATION` command. The margining levels, along with undervoltage and overvoltage supervisor fault thresholds, are preset according to the following table. These values are relative to the nominal output voltage created by R1 and R2.

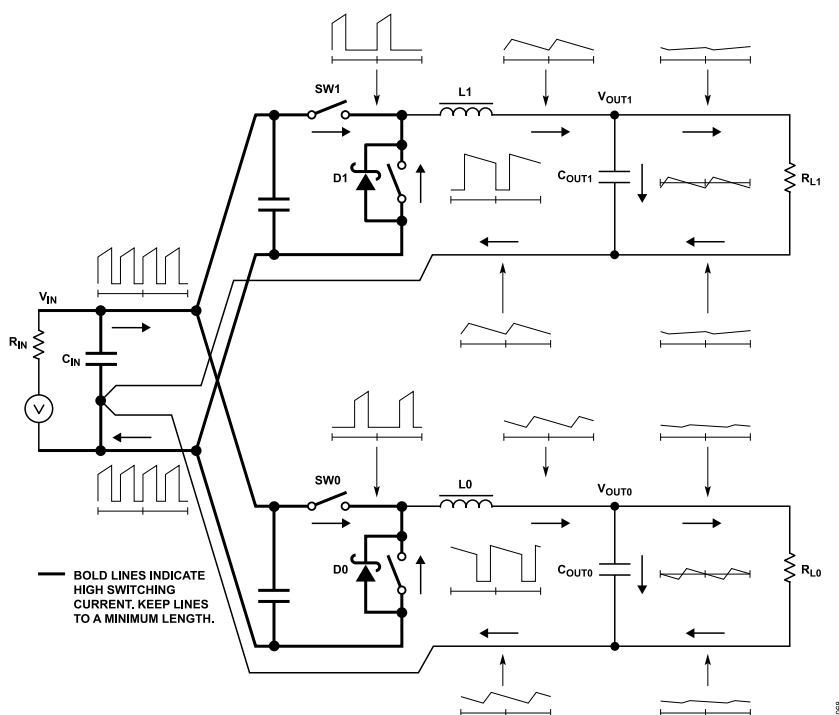

Figure 65. High Frequency Paths and Branch Current Waveforms

APPLICATIONS INFORMATION

Table 13. Factory EEPROM Output-Related Settings (LTC3888-1)

Quantity	PMBus Command	Value
UV Threshold	VOUT_UV_FAULT_LIMIT	-10%
Margin Low	VOUT_MARGIN_LOW	-5%
Margin High	VOUT_MARGIN_HIGH	+5%
OV Threshold	VOUT_OV_FAULT_LIMIT	+10%

Under and overvoltage warning limits are effectively disabled by the default factory EEPROM settings. Several other points should also be carefully noted when using the LTC3888-1 default factory configuration.

1. In this mode VOUT_TRANSITION_RATE (in V/ms) applies to the V_{FB} point, not V_{OUT} . Absolute slew rates at V_{OUT} will then be scaled by a factor of $(R1 + R2)/R2$.
2. In this mode, bit 6 of MFR_PWM_MODE_LTC3888 must be left clear, which is the factory default. V_{OUT} servo should not be used with these EEPROM settings. Refer to PWM Control Loops in [Electrical Characteristics](#) for device tolerances that apply to V_{OUT} accuracy in this case. Also refer to command details for MFR_PWM_MODE_LTC3888. Proper use of V_{OUT} servo in full PMBus control context is covered in the next few paragraphs.

PMBUS OUTPUT VOLTAGE CONTROL

It is also possible to utilize the full range of digitally programmable output voltage controls afforded by the PMBus interface once external components R1 and R2 have been chosen. The following steps should be taken to properly enable this control mode on the LTC3888-1.

1. Disable the master (page) that will utilize full PMBus control by using the RUN pin or OPERATION command.
2. Program VOUT_SCALE_LOOP to a value equal to $(R1 + R2)/R2$.
3. While internal calculations are performed to implement this change in output control mode, wait for bits[6:5] of MFR_COMMON to both be clear. This may take as much as 500 ms.
4. Program VOUT_COMMAND to the value desired (range of 300 mV to 3.45 V). See VOUT_MAX details below for limitations on this value.
5. Program related values for V_{OUT} margins, warning levels and hard supervisor thresholds (UV/OV) using good practices for the bracketing of nominal V_{OUT} with these quantities.
6. Re-enable the output using RUN pin and/or OPERATION command. V_{OUT} servo can also be enabled before the rail is turned on, or at any time afterward. See Using Output Voltage Servo below for details.

Steps 4-6 apply to the LTC3888/LTC3888-1/LTC3888-2.

Once direct PMBus control of VOUT is established in this way, VOUT_TRANSITION_RATE then applies to the output voltage proper, not V_{FB} . Also, when using VOUT_SCALE_LOOP on the LTC3888-1, some restrictions apply.

1. VOUT_SCALE_LOOP cannot be changed on the fly. The rail must be commanded off by RUN pin or OPERATION command. Bits[6:5] of MFR_COMMON should be polled whenever this command value is written. A rail-off update time of up to 500 ms may be required. During this period, processing of any other V_{OUT} -related commands sent to the LTC3888-1 will be delayed until new VOUT_SCALE_LOOP calculations have completed. It is strongly recommended to set this value just once after the desired value of $(R1 + R2)/R2$ is determined.
2. Sending V_{OUT} -related commands to the LTC3888-1 or re-enabling the output before the device indicates it has completed processing of VOUT_SCALE_LOOP for that channel may result in erroneous faults or undesirable controller operation.
3. VOUT_MAX is a read-only command that returns a value based on VOUT_SCALE_LOOP (LTC3888-1), with a maximum given by the read-only value of MFR_VOUT_MAX. This calculated value sets the maximum output that can be programmed with a particular R1/R2 combination for nominal V_{OUT} , margin or fault. See command details for VOUT_MAX. VOUT_MAX is fixed in the LTC3888 at 3.75 V.

USING OUTPUT VOLTAGE SERVO

For best output voltage accuracy, enable V_{OUT} servo mode on the master phase by setting bit 6 of MFR_PWM_MODE_LTC3888 once PMBus output control is fully programmed. In V_{OUT} servo mode, the LTC3888 will adjust the regulated output voltage based on its related monitor ADC reading. Every time that output voltage ADC channel is converted, the V_{OUT} servo will step the internal EA reference by 297.5 μ V until the output produces the correct ADC reading.

In order for the LTC3888-1 to servo V_{OUT} , VOUT_SCALE_LOOP must be used. The LTC3888/LTC3888-2 can always servo. This will allow the final V_{OUT} created by the servo at any condition to have $\pm 0.2\%$ typical accuracy ($\pm 0.5\%$ absolute maximum). The raw output created by the application must be within $\pm 5.5\%$ of VOUT_COMMAND for the V_{OUT} servo to function to full effectiveness, so external feedback resistors with $\pm 0.5\%$ tolerance are recommended.

When the master channel is turned on, V_{OUT} servo is enabled after all of the following conditions are satisfied.

- ▶ Bit 6 of MFR_PWM_MODE_LTC3888 Is Set
- ▶ The Soft-Start Sequence Is Complete
- ▶ A VOUT_UV_FAULT Is Not Present
- ▶ An IOUT_OC_FAULT Is Not Present

V_{OUT} servo mode then engages after TON_MAX_FAULT_LIMIT has expired as shown in [Figure 66](#), unless that limit is set to 0 s (infinite). In that case, the mode is engaged as soon as the above conditions are satisfied.

APPLICATIONS INFORMATION

SOFT-START AND STOP

The LTC3888 uses digital ramp control to create both soft-start and soft-stop.

The LTC3888 must enter the run state prior to soft-start. The RUN pins are released after the part initializes and V_{IN} is determined to be greater than the V_{IN_ON} threshold.

Once in the run state, soft-start is performed after any additional prescribed delay (see next section) by actively regulating the load voltage while digitally ramping the target voltage from 0 V to the final expected value. Rise time of the voltage ramp can be programmed using $V_{OUT_TRANSITION_RATE}$ (LTC3888-1) or TON_RISE (LTC3888/LTC3888-2) to minimize inrush currents associated with the start-up voltage ramp. The maximum rate at which the LTC3888 can move the output in this fashion is 100 $\mu\text{s}/\text{step}$. Soft-start is disabled by setting $V_{OUT_TRANSITION_RATE}$ to 4 V/ms (LTC3888-1) or TON_RISE (LTC3888/LTC3888-2) less than 250 μs . The LTC3888 will internally perform the math necessary to assure the voltage ramp is controlled to the desired slope. However, the voltage slope cannot be any faster than fundamental limits imposed by the power stage. The larger $V_{OUT_TRANSITION_RATE}$ (LTC3888-1) or TON_RISE (LTC3888/LTC3888-2) becomes, the more noticeable an output voltage stair-step may become.

The LTC3888 also supports soft turn off in the same manner it controls turn on. Soft-off is performed when the RUN pin goes low or if the part is commanded off. The LTC3888 can produce a controlled ramp off as long as $V_{OUT_TRANSITION_RATE}$ (LTC3888-1) or $TOFF_FALL$ (LTC3888/LTC3888-2) is sufficiently slow to allow the control loop and power stage to achieve the desired slope. If $V_{OUT_TRANSITION_RATE}$ (LTC3888-1) or $TOFF_FALL$ (LTC3888/LTC3888-2) is too high to discharge the load capacitance, the output will not reach 0 V. In this case, the power stage will still be commanded off at the end of soft-off and V_{OUT} will decay at a rate determined by the load. The larger $V_{OUT_TRANSITION_RATE}$ (LTC3888-1) or $TOFF_FALL$ (LTC3888/LTC3888-2) becomes, the more noticeable an output voltage stair-step may become. If a rail faults off for any reason, all related PWM phases are instantly commanded off. The output will then decay as a function of load current.

TIME-BASED OUTPUT SEQUENCING AND RAMPING

The LTC3888 TON_DELAY and $TOFF_DELAY$ commands can be used in combination with $V_{OUT_TRANSITION_RATE}$ (LTC3888-1) or TON_RISE and $TOFF_FALL$ (LTC3888/LTC3888-2) to implement a wide range of versatile sequencing and ramping schemes. The key to time-based sequencing and ramping is the ability of LTC3888 master phases to move their outputs up and down according to PMBus command values as shown in Figure 66 and Figure 67.

There is a fixed delay and other timing uncertainty associated with all changes in output voltage controlled by the LTC3888. A nominal fixed timing delay of 270 μs exists to process any change in output voltage including soft-start/stop and margining. The start of all time-based output operations occur with an uncertainty of $\pm 50 \mu\text{s}$ and have a nominal step resolution of 100 μs . This means the minimum controlled time delay the LTC3888 can produce will range from 220 μs to 320 μs , not including basic oscillator tolerances. For software-based output changes (e.g., margining), this algorithmic delay begins when the STOP bit is received on the PMBus. An example of this minimum turn on/off delay and step-wise output control can be seen in Figure 69, where $TON_DELAY = 0 \text{ s}$.

To effectively implement tracking and sequencing between rails controlled by ADI digital power products, two signals should be shared between all controlling ICs: $SHARE_CLK$ and RUN (CONTROL pin on LTC297x products). This facilitates synchronized rail sequencing on or off based on shared input supply state (V_{IN_ON} threshold), external hardware control (RUN pin), or PMBus commands (possibly using global addressing).

Figure 69 shows an example of output supply sequencing using TON_DELAY .

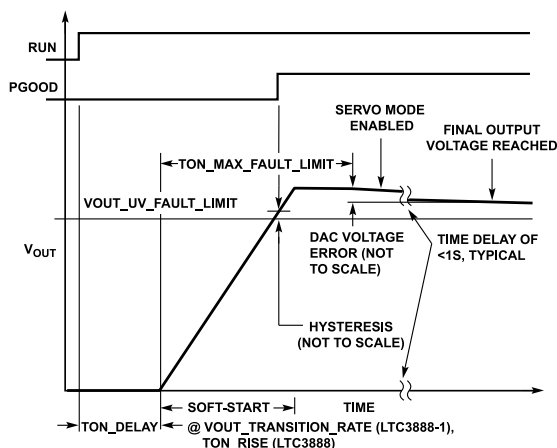

Figure 66. Time-Based V_{OUT} Turn-On with Servo

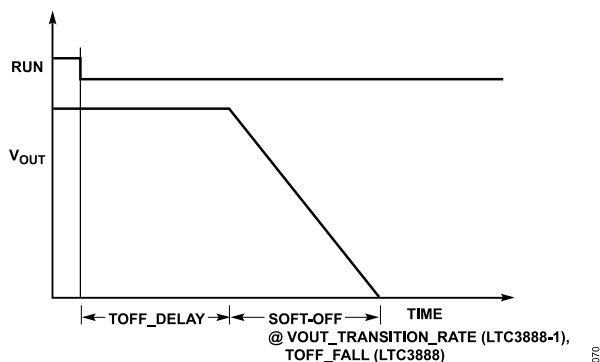

Figure 67. Time-Based V_{OUT} Turn-Off

APPLICATIONS INFORMATION

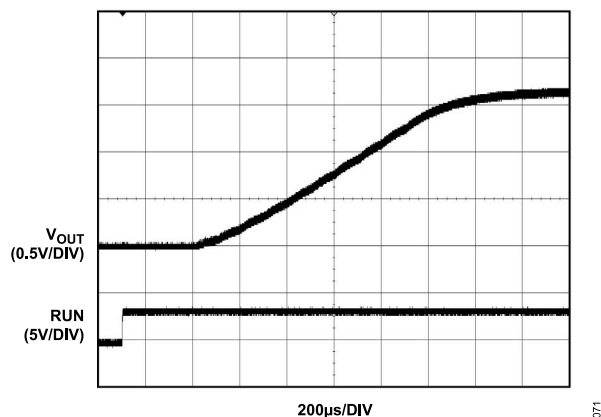

Figure 68. Example of Fixed LTC3888-1 Processing Delay and Soft-Start

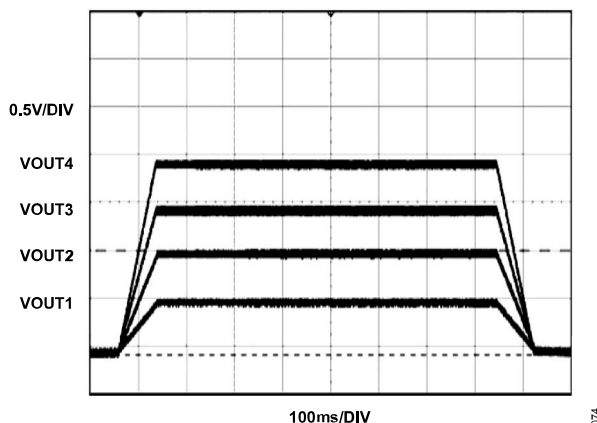

Figure 71. LTC3888-1 Time-Based Ratiometric Supply Ramping

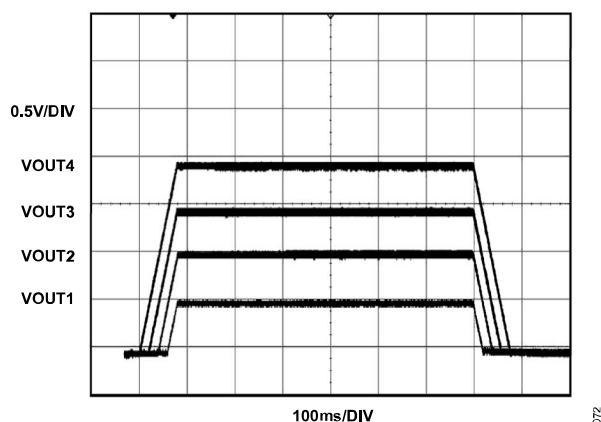

Figure 69. LTC3888-1 Time-Based Supply Sequencing

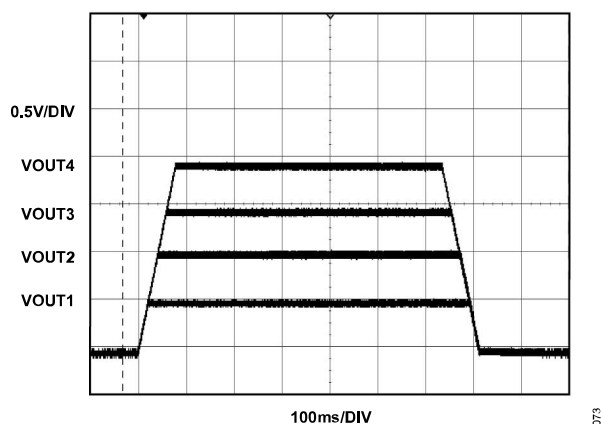

Figure 70. LTC3888-1 Time-Based Coincident Supply Ramping

Conventional coincident and ratiometric tracking can also be emulated by setting equivalent turn-on/off delays and appropriate rates as shown in Figure 70 and Figure 71.

In addition, these schemes can easily be mixed and matched to create any necessary ramping controls, some of which might prove difficult to implement with conventional analog-only controllers. These programmable features greatly simplify system development because rails can be resequenced without a hardware change as final product requirements evolve. The LTpowerPlay GUI and LTC3888 onboard EEPROM can be used for this task, avoiding the need for firmware development to modify turn on/off relationships between rails. Entire power systems can easily be scaled up or down, facilitating reuse of proven hardware macro designs.

VOLTAGE-BASED OUTPUT SEQUENCING

The LTC3888 is capable of voltage-based output sequencing. For concatenated events between members of the ADI PSM family, it is possible to control one RUN pin from a $\overline{\text{GPIO}}$, FAULT or PGOOD pin of a different controller. A hardware configuration of the type shown in Figure 72 disables the next downstream controller anytime the upstream output is below the specific UV threshold. If $\overline{\text{GPIO}}$ or FAULT is used, the controlling output must be configured to only propagate VOUT_UV_UF, and that IC must have its MFR_GPIO/FAULT_RESPONSE set to ignore (0x00). Use of the unfiltered V_{OUT} UV fault limit is recommended because there is less delay between crossing the UV threshold and the $\overline{\text{GPIO}}$ /FAULT pin releasing. When $\overline{\text{GPIO}}$ /FAULT UV propagation is utilized, an output deglitching filter can ensure the control does not toggle repeatedly at lower values of output transition due to noise on V_{OUT}. If unwanted transitions still occur with only the internal filter found on most ADI PSM devices (typically 70 μs), place a capacitor to ground on the output pin. The RC time-constant of the filter should be low enough to assure no appreciable delay is incurred. A value of 300 μs to 500 μs will provide some additional filtering without significant delay of the trigger event.

APPLICATIONS INFORMATION

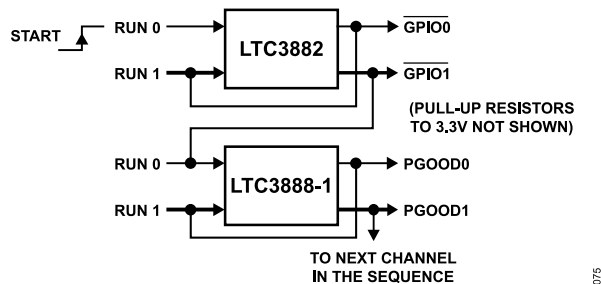

Figure 72. Cascade Sequencing Configuration Example

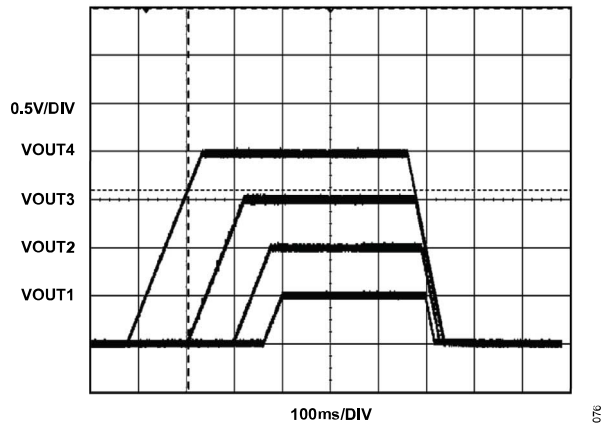

Figure 73. Cascade Sequencing Waveforms

When the system is turned off, rails will shut down in the same order as they turn on, as shown in Figure 73. If a different sequence is required, the circuit must be rewired or delays must be added by programming `TON_DELAY` or `TOFF_DELAY`. A fundamental limitation of this application is the inability of upstream rails to detect a start-up failure of downstream rails. Due to this, cascade sequencing should not be implemented without an external fast supervisor to monitor downstream rails and assert a system fault if problems occur.

PWM FREQUENCY SYNCHRONIZATION

The LTC3888 incorporates an internal phase-locked loop (PLL) which enables synchronization of all PWM channels to an external CMOS clock from 250 kHz to 1 MHz. The PLL is locked to the falling edge of the SYNC pin clock signal. For synchronization required by the application, SYNC may be driven from a separate source, including another LTC3888 or other ADI PSM device. If SYNC is not externally clocked, the PWMs will operate at the frequency specified by the `FREQUENCY_SWITCH` command.

All ICs of a PolyPhase rail may be required to share SYNC pins. If phase expansion for a single rail is all that is required, the IC providing the master clock simply drives the clock slave IC SYNC input

with its CLKOUT. If SYNC is shared between ADI PSM devices, only one device should be programmed to control the SYNC output. Refer to the following section for additional PolyPhase details.

The PLL generates very accurate channel phase relationships which can be selected with `MFR_PWM_CONFIG_LTC3888`. For PolyPhase applications, all phases should be spaced evenly around the unit circle for best results. For instance, a 4-phase system should use a separation of 90° between channels.

The PLL has a lock detection circuit. If the PLL should lose lock during operation, bit 4 of the `STATUS_MFR_SPECIFIC` command is asserted and the `ALERT` pin is pulled low, if not masked. The fault can be cleared by writing a 1 to `STATUS_MFR_SPECIFIC` bit 4.

POLYPHASE OPERATION AND LOAD SHARING

Single IC PolyPhase LTC3888 configuration are controlled by bits [2:0] of `MFR_PWM_CONFIG_LTC3888`. All necessary slave phase control is managed internal to the device in this case. When operating a high power rail requires between ten and sixteen phases, the LTC3888 affords dual-IC phase expansion to keep those phases ideally spaced around the unit circle as shown in Figure 74. To do this, bit 3 of `MFR_PWM_CONFIG_LTC3888` is set, making that device the clock master. The `PGOOD0` pin is redefined to provide CLKOUT to drive the SYNC input of the second LTC3888. A pull-up resistor to 3.3 V is still required on CLKOUT. Bits[2:0] of `MFR_PWM_CONFIG_LTC3888` are then set to the same value on both ICs, yielding the following additional dual-IC rail configurations:

- ▶ 10 + (1 or 3) + (1 or 3)
- ▶ 12 + (1 or 2) + (1 or 2)
- ▶ 14 + 1 + 1
- ▶ 16-phase

As shown in Figure 74 master channel 0 and its assigned slaves from the two ICs combine to form a single high phase count rail with ideal phase separation, in this case $360/12 = 30$ degrees. While a great deal of flexibility exists in utilizing the remaining voltage control loops and slaves, some phasing limitations do exist. For example, in a 10-phase case, the remaining three phases on each IC are separated by 120 degrees, so a 2-phase rail built from one of those loops would not be capable of 180° phasing. The two remaining loops would also not produce uniform 60° separation if combined into a single 6-phase rail. While none of the phases on these remaining two 3-phase loops overlap each other, one or more may overlap those of the primary high count rail.

Whether using the phase expansion feature of the LTC3888 or not, the following pins should be shared between two or more devices on a large PolyPhase rail:

- ▶ V_{IN} (if separate ICs)
- ▶ $V_{SENSE\pm}$ (see previous Output Voltage Sensing discussion)
- ▶ I_{TH}/I_{THR}

APPLICATIONS INFORMATION

- ▶ TSNS/VDR_MON
- ▶ SYNC (if not using phase expansion)
- ▶ I²C bus pins (SCL, SDA)
- ▶ $\overline{\text{ALERT}}$
- ▶ $\overline{\text{FAULT}}$ pins
- ▶ RUN
- ▶ SHARE_CLK (if separate ICs)

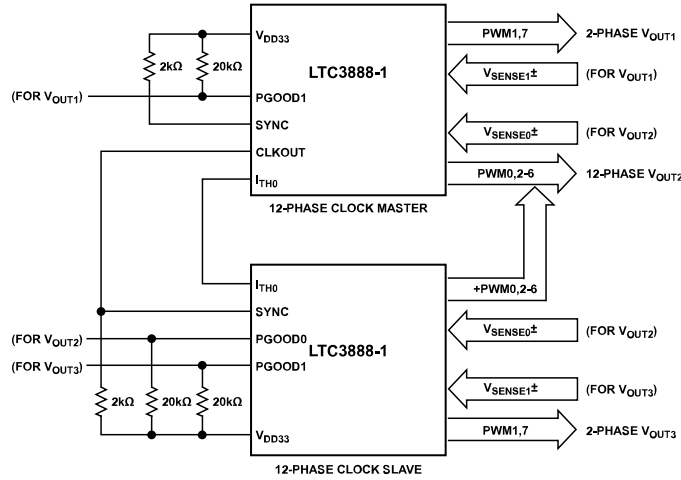

NOTE: SOME DETAILS OMITTED FOR CLARITY

Figure 74. Simplified Schematic Showing 12 + 2 + 2 Phase Expansion

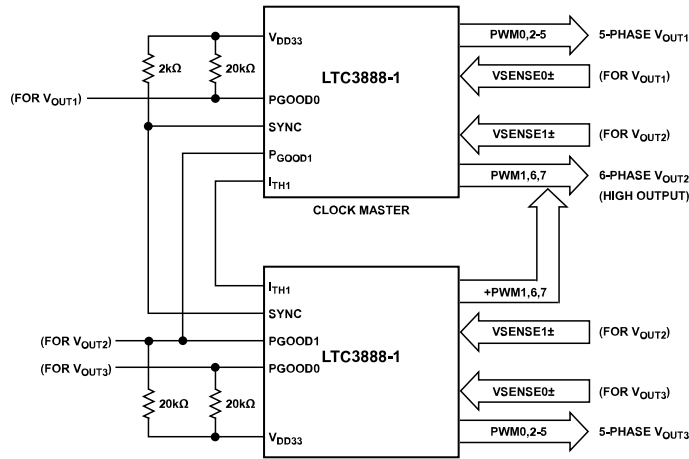

NOTE: SOME DETAILS OMITTED FOR CLARITY

Figure 75. Simplified Schematic Showing 5 + 5 + 6 Application

APPLICATIONS INFORMATION

When I_{TH} pins are shorted, one I_{THR} pin can be selected to apply primary loop compensation, with all other I_{THR} pins shorted to the common I_{TH} . Alternatively, all I_{THR} pins can be shorted, making the effective resistance the parallel combination of all these R_{ITH} . This will reduce dynamic range of R_{ITH} but will increase programming resolution.

Linear regulator outputs such as V_{DD33} and resistor configuration pins, including R_{SET} , should not be shared between devices. PGOOD may be shared between all master channels on a single rail, or a single PGOOD output can be selected to indicate the rail output voltage is in regulation.

At any point that additional output current is required without the need for additional phase separation, it is always possible to simply add overlapping phases on an LTC3888 rail. For example, two LTC3888s can be combined to provide two 5-phase rails with a third 6-phase rail with two PWMs driving each phase. In this case, SYNC would be shared between the ICs (one configured as clock master) and all rails would have phases with the desired uniform spacing around the unit circle. Refer to [Figure 75](#).

Load sharing accuracy is based on the power stage output current monitor interface of each slave phase. The gain matching errors of these channels tend to be small and negligible. The input-referred offset of the LTC3888 current interface is trimmed at the factory but will still dominate the sharing error budget, especially at lower phase current levels. Specifications for on-chip and off-chip output current matching are given in the [Electrical Characteristics](#) table. These specifications do not include the current error created by mismatch of the output current monitors of the individual power stages.

Every master channel on a rail should use identical values for all PMBus commands related to output voltage control (including margin and start/stop timing), input and output warning limits (both voltage and current), all fault limits and associated responses, and all PWM configuration controls. The correct current sense gain should also be set for each master ($I_{OUT_CAL_GAIN}$) to achieve accurate I_{OUT} telemetry and consistent fault handling across phases.

A PolyPhase power supply significantly reduces the amount of ripple current in both the input and output capacitors. The RMS input ripple current is divided by, and the effective ripple frequency is multiplied by, the number of phases used as long as the input voltage is greater than the number of phases times the output voltage. Output voltage ripple amplitude is also reduced by the number of phases used. [Figure 76](#) graphically illustrates the principle.

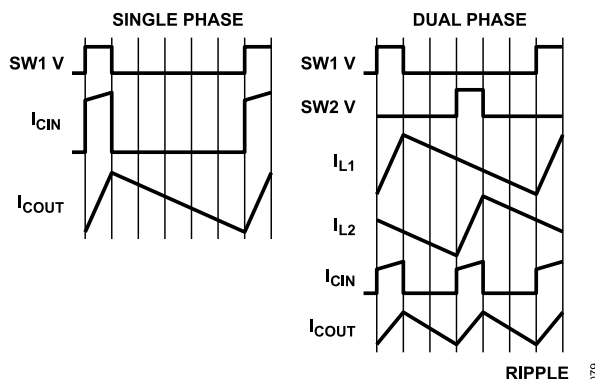

Figure 76. Single and 2-Phase Current Waveforms

The worst-case RMS ripple current for a single stage design peaks at an input voltage of twice the output voltage. The worst case RMS ripple current for a 2-phase design peaks at output voltages of one-quarter and three-quarters of the input voltage. When the RMS current is calculated, higher effective duty factor results and the peak current levels are divided as long as the current in each stage is balanced. Refer to [Application Note 19](#) for a detailed description of how to calculate RMS current for a single stage switching regulator. [Figure 77](#) and [Figure 78](#) illustrate how the input and output currents are reduced by using an additional phase. For a 2-phase converter, the input current peaks drop in half and the frequency is doubled. The input capacitor requirement is then theoretically reduced by a factor of four.

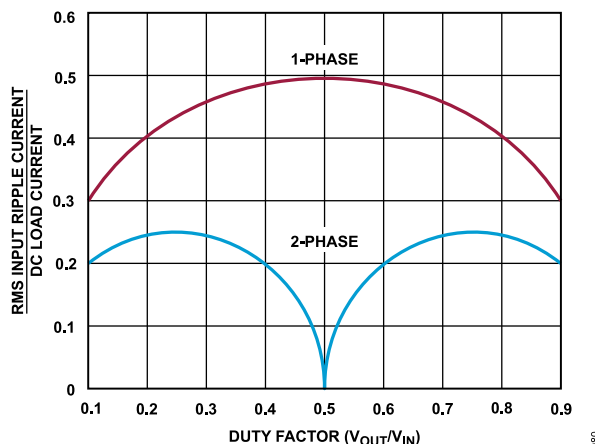

Figure 77. Normalized RMS Input Ripple Current

APPLICATIONS INFORMATION

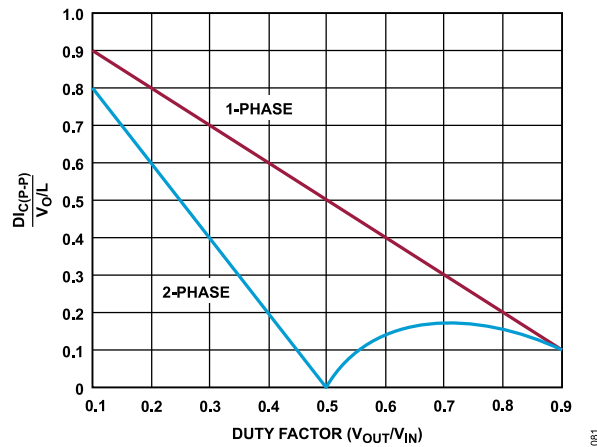

Figure 78. Normalized Output Ripple Current

RESISTOR CONFIGURATION PINS

As a factory default, the LTC3888 is programmed to use external resistor configuration, allowing output voltage (LTC3888/LTC3888-2), output current limit (LTC3888-1), PWM frequency and phasing, and the PMBus address to be set without programming the part through its serial interface or purchasing devices with custom EEPROM contents. An 18.7 k Ω resistor with a tolerance of 1% or better must be wired between the R_{SET} pin and GND. This component establishes the correct bias level for the remaining RCONFIG pins, which are programmed with a resistor to GND. The RCONFIG pins are only interrogated at initial power up and during a reset, so modifying their values on the fly is not recommended.

Table 14. Resistor Programming of V_{OUT} (LTC3888/LTC3888-2) and OC Limits (LTC3888-1)

R _{CONFIG} (k Ω)	LTC3888/LTC3888-2		LTC3888-1	
	V _{OUT} (V)	OPERATION	IOUT_OC_WARN_LIMIT (A)	IOUT_OC_FAULT_LIMIT (A)
OPEN	From EEPROM	From EEPROM	From EEPROM	From EEPROM
11.8	3.3	On	68	85
10.2	2.5	On	64	80
9.31	1.8	On	60	75
8.66	1.5	On	56	70
7.87	1.25	On	52	65
7.15	1.2	On	48	60
6.49	1.1	On	44	55
5.9	1.0	On	40	50
5.11	0.9	On	36	45
4.42	0.8	On	32	40
3.74	0.75	On	28	35
3.09	0.7	On	24	30
2.43	0.65	On	20	25
1.74	0.6	On	16	20
1.02	0.5	On	12	15
GND	From EEPROM	Off	8	10

RCONFIG pins on the same IC can share a single resistor if they require identical programming. Resistors with a tolerance of 1% or better must be used to assure proper operation. Noisy clock signals should not be routed near these pins.

Output voltage (LTC3888/LTC3888-2), or output current limit (LTC3888-1) can be set as shown in Table 14. For example, setting this resistor to 4.42 k Ω is equivalent to programming a IOUT_OC_WARN_LIMIT value of 32 A with IOUT_OC_FAULT_LIMIT set to 40 A for the (LTC3888-1).

Any of the single-IC master/slave configurations that the LTC3888 supports can be programmed with PWM_CFG using one of two frequencies as shown in Table 15. Phase expansion is not supported when using an external resistor to set master/slave configuration.

The LTC3888 address is selected based on the programming of the two configuration pins ASEL0 and ASEL1 according to Table 16. ASEL0 programs the bottom four bits of the device address for the LTC3888, and ASEL1 programs the three most-significant bits. Either portion of the address can also be retrieved from the MFR_ADDRESS value in EEPROM. If both pins are left open, the full 7-bit MFR_ADDRESS value stored in EEPROM is used to determine the device address. It is recommended that each LTC3888 in a system have a unique address, and the ASEL pins provide an efficient way to accomplish this without a plethora of custom EEPROM programming. The LTC3888 also responds to 7-bit global addresses 0x5A and 0x5B. MFR_ADDRESS and MFR_RAIL_ADDRESS should not be set to either of these values.

APPLICATIONS INFORMATION

Table 15. PWM_CFG Resistor Programming

R _{CONFIG} (kΩ)	MFR_PWM_CONFIG_LTC3888[3:0]		SWITCHING FREQUENCY (kHz)
	BINARY	MASTER/SLAVE	
OPEN		from EEPROM	
11.8	0111	7 + 1	550
10.2	0110	6 + 2	
9.31	0101	6 + 1	
8.66	0100	5 + 3	
7.87	0011	4 + 4 (or 8-phase)	
7.15	0010	4 + 3	
6.49	0001	4 + 2	
5.9	0000	3 + 3	
5.11	0111	7 + 1	450
4.42	0110	6 + 2	
3.74	0101	6 + 1	
3.09	0100	5 + 3	
2.43	0011	4 + 4 (or 8-phase)	
1.74	0010	4 + 3	
1.02	0001	4 + 2	
GND	0000	3 + 3	

Table 16. Resistor Programming of MFR_ADDRESS

R _{CONFIG} (kΩ)	ASEL1		ASEL0	
	DEVICE ADDRESS BITS[6:4]		DEVICE ADDRESS BITS[3:0]	
	BINARY	HEX	BINARY	HEX
OPEN		from EEPROM		from EEPROM
11.8			1111	F
10.2			1110	E
9.31			1101	D
8.66			1100	C
7.87			1011	B
7.15			1010	A
6.49			1001	9
5.9			1000	8
5.11	0111	7	0111	7
4.42	0110	6	0110	6
3.74	0101	5	0101	5
3.09	0100	4	0100	4
2.43	0011	3	0011	3
1.74	0010	2	0010	2
1.02	0001	1	0001	1
GND	0000	0	0000	0

INTERNAL REGULATOR OUTPUTS

The INTV_{CC} pin provides supply current for much of the internal LTC3888 analog circuitry at a nominal value of 5.2 V. The LTC3888

features an internal linear regulator that can be used to supply 5.2 V to INTV_{CC} from the primary V_{IN} supply. At lower supply voltages, the LTC3888 will also accept an external 5 V supply attached to this pin if V_{IN} and INTV_{CC} are shorted. If the internal 5.2 V LDO is

APPLICATIONS INFORMATION

used, INTV_{CC} must be bypassed to GND with a low ESR X5R or X7R ceramic capacitor with a value between 1 μF and 4.7 μF. If an external 5 V source supplies V_{IN} and INTV_{CC}, a local low ESR bypass capacitor with a value between 0.01 μF and 0.1 μF should be placed directly between the shorted power pins and GND.

INTV_{CC} powers secondary internal 3.3 V and 2.5 V LDOs whose outputs are present on V_{DD33} and V_{DD25}, respectively. The 3.3 V supply provides power for internal auxiliary circuits, and the 2.5 V supply provides power for much of the internal processor logic on the LTC3888. Both of these LDO outputs should be bypassed directly to GND with a low ESR X5R or X7R ceramic capacitor with a value of 1 μF or greater.

Do not draw any external system current from these LDO supplies beyond that required for specific LTC3888 configuration or load/pull-up resistors.

IC JUNCTION TEMPERATURE

The user must ensure that the maximum rated junction temperature is not exceeded under all operating conditions. The thermal resistance of the LTC3888 package (θ_{JA}) is 36°C/W, provided the exposed pad is in good thermal contact with the PCB. The actual thermal resistance in the application will depend on forced air cooling and other heat sinking means, especially the amount of copper on the PCB to which the LTC3888 is attached. The following formula may be used to estimate the maximum average power dissipation P_D (in watts) of the LTC3888.

$$P_D = V_{IN} \cdot (I_{EXT} + I_{RC25})$$

where:

I_{EXT} = total external load drawn from V_{DD33}, including local pull-up resistors, in amps

I_{RC25} = total current drawn from V_{DD25} by LTC3888 configuration resistors, in amps

and f_{PWM} is the PWM switching frequency in kHz

The maximum junction temperature of the LTC3888 in °C may then be found from the following equation

$$T_J = T_A + 36 \times P_D$$

with ambient temperature T_A expressed in °C

DERATING EEPROM RETENTION AT TEMPERATURE

EEPROM read operations between 85°C and 125°C will not affect data storage. But retention will be degraded if the EEPROM is written above 85°C or stored or operated above 125°C. If an occasional fault log is generated above 85°C, the slight reduction in data retention in the EEPROM fault log area will not affect the use of the function or other EEPROM storage. See the [Theory of Operation](#) section for other high temperature EEPROM functional details. Degradation in data retention can be approximated by

calculating the dimensionless acceleration factor using the following equation.

$$AF = e \left[\left(\frac{E_a}{k} \right) \times \left(\frac{1}{T_{USE} + 274} - \frac{1}{T_{STRESS} + 273} \right) \right]$$

Where:

AF = acceleration factor

E_a = activation energy = 1.4 eV

k = 8.617 × 10⁻⁵ eV/°K

T_{USE} = is the specified junction temperature

T_{STRESS} = actual junction temperature in °C

As an example, if the device is stored at 130°C for 10 hours,

T_{STRESS} = 130°C, and

$$AF = e \left[\left(\frac{1.4}{8.617 \times 10^{-5}} \right) \times \left(\frac{1}{398} - \frac{1}{403} \right) \right] = 1.66$$

indicating the effect is the same as operating the device at 125°C for 10 × 1.66 = 16.6 hours, resulting in a retention derating of 6.6 hours.

CONFIGURING OPEN-DRAIN PINS

The LTC3888 has the following open-drain pins:

► 3.3 V Pins

1. PGOOD0/CLKOUT
2. PGOOD1
3. FAULT0, FAULT1
4. SYNC
5. SHARE_CLK

► 5 V Capable Pins

(These pins operate correctly when pulled to 3.3 V.)

1. RUN0, RUN1
2. ALERT
3. SCL
4. SDA

Most of the above pins have on-chip pull-down transistors that can sink 3 mA at 0.4 V. The low state threshold on these pins provides ample noise margin with 3 mA of current. For 3.3 V pins, 3 mA of current is produced by a 1.1 k pull-up resistor. Unless there are transient speed issues associated with the RC time constant of the net, a 10 k resistor or larger is generally recommended.

The pull-up resistor for PGOOD should be terminated to the LTC3888 V_{DD33} pin or a separate bias supply under 3.6 V that

APPLICATIONS INFORMATION

is up before the LTC3888 is enabled. Otherwise, power-not-good may be falsely indicated after the PWM outputs are running.

For high speed signals such as SDA and SCL, a lower value resistor may be required. The RC time constant should be set to one-third to one-fifth the required rise time to avoid timing issues. For a 100 pF load and a 400 kHz PMBus communication rate, the resistor pull-up on the SDA and SCL pins with the time constant set to one-third the required rise time equals

$$R_{PULLUP} = \frac{t_{RISE}}{3 \times 100 \text{ pF}} = 1 \text{ k}\Omega$$

The closest 1% resistor value is 1 kΩ. Limit to 1.1 kΩ for best noise margin.

Be careful to minimize parasitic capacitance on the SDA and SCL lines to avoid communication problems. To estimate the loading capacitance, monitor the signal in question and measure how long it takes for the desired signal to reach approximately 63% of the output value. This is one time constant.

The SYNC pin has an on-chip pull-down transistor with the output held low for nominally 500 ns when driven by the LTC3888. If the internal oscillator is set for 500 kHz and the load is 100 pF with a one-third rise time required, the resistor calculation is as follows:

$$R_{PULLUP} = \frac{2 \text{ } \mu\text{s} - 500 \text{ ns}}{3 \times 100 \text{ pF}} = 5.0 \text{ k}\Omega$$

The closest 1% resistor is 4.99 kΩ.

If timing errors are occurring or if the SYNC amplitude is not as large as required, monitor the waveform and determine if the RC time constant is too long for the application. If possible reduce the parasitic capacitance. Otherwise reduce the pull-up resistor sufficiently to assure proper operation.

Similar results ($R < 5 \text{ k}\Omega$) should be applied to the PGOOD0 output when configured as CLKOUT to ensure proper clocking of the slave IC.

The SHARE_CLK output has a nominal period of 10 μs and is pulled low for about 1 μs. If the system load on this shared line is 100 pF, the resistor calculation for this line with a one-third rise time is:

$$R_{PULLUP} = \frac{9 \text{ } \mu\text{s}}{3 \times 100 \text{ pF}} = 30 \text{ k}\Omega$$

The closest 1% resistor is 30.1 kΩ.

PMBUS COMMUNICATION AND COMMAND PROCESSING

The LTC3888 has a one deep buffer to hold the last data written for each supported command prior to processing, as shown in Figure 79. Two distinct parallel sections of the LTC3888 manage command buffering and command processing to ensure the last data written to any command is never lost. When the part receives a new command from the bus, command data buffering copies the data into the write command data buffer and indicates to the

internal processor that data for that command should be handled. The internal processor runs in parallel and performs the sometimes slower task of fetching, converting (to internal format) and executing commands marked for processing.

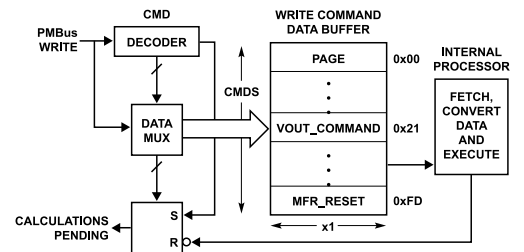

Figure 79. Write Command Data Processing

Some computationally intensive commands (e.g., timing parameters, temperatures, voltages and currents) have internal processor execution times that may be long relative to PMBus timing. If the part is busy processing a command, and a new command(s) arrives, execution may be delayed or processed in a different order than received. The part indicates when internal calculations are in process with bit 5 of MFR_COMMON (Internal Calculations Not Pending). When the internal processor is busy calculating, bit 5 is cleared. When this bit is set, the part is ready for another command. An example polling loop is provided in Figure 79, which ensures that commands are processed in order while simplifying error handling routines. MFR_COMMON always returns valid data at PMBus speeds between 10 kHz and 400 kHz.

When the part receives a new command while it is busy, it will communicate this condition using standard PMBus protocol. Depending on device configuration and state it may either NACK the command or return all ones (0xFF) for reads. It may also generate a BUSY fault and ALERT notification, or stretch the SCL clock low. For more information refer to PMBus Specification V1.2, Part II, Section 10.8.7 and SMBus V2.0 section 4.3.3. Clock stretching can be enabled by asserting bit 1 of MFR_CONFIG_ALL. Clock stretching will only occur if enabled and the bus communication speed exceeds 100 kHz.

PMBus protocols for busy devices are well accepted standards but can make writing system level software somewhat complex. The part provides three handshaking status bits which reduce this complexity while enabling robust system level communication. The three hand shaking status bits are in the MFR_COMMON register. When the part is busy executing an internal operation, it will clear bit 6 of MFR_COMMON (Chip Not BUSY). When internal calculations are in process, the part will clear bit 5 of MFR_COMMON (Internal Calculations Not Pending). When the part is busy specifically because it is transitioning V_{OUT} (margining or on/off) it will clear bit 4 of MFR_COMMON (Output Not In Transition). These three status bits can be polled with a PMBus read byte of the MFR_COMMON register until all three bits are set. A command immediately following all these status bits being set will be accepted without a NACK, BUSY fault or ALERT notification. The part can

APPLICATIONS INFORMATION

NACK commands for other reasons, however, as required by the PMBus specification (e.g., an invalid command or data).

An example of a robust command write algorithm for the VOUT_COMMAND register is provided in [Figure 80](#). It is recommended that all command writes be preceded with such a polling loop to avoid the extra complexity of dealing with busy behavior or unwanted ALERT notifications. A simple way to achieve this is to embed the polling in subroutines to write command bytes and words. This polling mechanism will allow system software to remain clean and simple while robustly communicating with the part.

When communicating using bus speeds at or below 100 kHz, the polling mechanism previously shown provides a simple solution that ensures robust communication without clock stretching. At bus speeds in excess of 100 kHz, it is strongly recommended that the part be enabled to use clock stretching, requiring a PMBus master that supports that function. Clock stretching does not allow the LTC3888 to communicate reliably on busses operating above 400 kHz. Operating the LTC3888 with PMBus SCL rates above 400 kHz is not recommended. System software that detects and properly recovers from the standard PMBus NACK responses or BUSY faults described in PMBus Specification V1.2, Part II, Section 10.8.7 is required to communicate above 100 kHz without clock stretching.

Refer to [Application Note 135](#) for techniques that may also apply to implement a robust PMBus interface to the LTC3888.

STATUS AND FAULT LOG MANAGEMENT

Due to internal operation, very infrequently the LS byte of STATUS_WORD may be inconsistent with the state of bits in the MS byte. This condition is quite transient and can normally be resolved by simply re-reading STATUS_WORD.

If power is lost during an internal store of a fault log to EEPROM, a partial write of the log can result. In this situation, the LTC3888 will indicate that a partial fault log is present the next time adequate supply voltage is applied by setting bit 3 of STATUS_MFR_SPECIFIC and bit 4 of STATUS_CML. Additional logging remains disabled. The only way to then determine how much of the log is actually valid is by subjective evaluation of the contents of each log event record. MFR_FAULT_LOG_CLEAR will permanently erase a partial fault log, allowing a subsequent log to be written. It is a good practice to always check for a partial fault log at power-up if fault logging is enabled (bit 7 of MFR_CONFIG_ALL).

Refer to [Fault Log Details](#) section in the [Theory of Operation](#) section for more details.

LTPOWERPLAY—AN INTERACTIVE DIGITAL POWER GUI

LTpowerPlay is a powerful Windows-based development environment that supports Analog Devices Power System Management ICs, including the LTC3888. LTpowerPlay can be used to evaluate

ADI products by connecting to an Analog Devices demo circuit or user application. LTpowerPlay can also be used offline (no hardware present) to build multiple IC configuration files that can be saved and later reloaded. LTpowerPlay uses the DC1613 USB-to-I²C/SMBus/PMBus controller to communicate with a system for evaluation, development or debug. The software also features automatic update to remain up-to-date with the latest application code and documentation available from Analog Devices. A great deal of context sensitive help is available within LTpowerPlay, along with several tutorials.

```
// wait until bits 6, 5, and 4 of MFR_COMMON are all set
do
{
    mfrCommonValue = PMBUS_READ_BYTE(0xEF);
    partReady = (mfrCommonValue & 0x68) == 0x68;
}while(!partReady)

// now the part is ready to receive the next command
PMBUS_WRITE_WORD(0x21, 0x2000); //write VOUT_COMMAND to 2V
```

Figure 80. Example of a Polling Loop to Write VOUT_COMMAND

INTERFACING TO THE DC1613

The ADI DC1613 USB-to-I²C/SMBus/PMBus controller can be interfaced to the LTC3888 on any board for programming, telemetry and system debug. This includes the DC2652 from Analog Devices, or any customer target system. The controller, when used in conjunction with LTpowerPlay, provides a powerful way to debug an entire power system. Faults are quickly diagnosed using telemetry, status registers and the fault log. A final design configuration can be quickly developed and stored to the LTC3888 EEPROM and/or LTpowerPlay configuration file.

The DC1613 can communicate with, program and even power one or more LTC3888 devices, regardless of whether system power is present. The DC2086 Powered Programming Adapter can be used to extend the power sourcing capability of the DC1613. [Figure 81](#) illustrates an application schematic for in-system programming of multiple LTC3888 devices normally powered from V_{IN}. If the DC2086 is used, PFETs with lower R_{DS(ON)}, such as the SiA907EDJT, should be used in place of the Si2305CDS devices. If system power is not present, the DC1613 or DC2086 will power the LTC3888 VDD33 supply, allowing in-circuit configuration or manufacturing customization. With V_{DD33} applied in this fashion, the device(s) can be initialized when the system is not powered by using PMBus address 0x5B to send a value of 0x2B to command 0xBD. If this is followed with a value of 0xC4 to 0xBD at address 0x5B, the LTC3888 will begin to communicate and allow PMBus command values to be updated at its normal PMBus device address. Any changes will become permanent (stored to EEPROM) by a subsequent STORE_USER_ALL command. When V_{IN} is reapplied, MFR_RESET must be executed to establish normal operation if command 0xBD has been used for communication in the absence of system power.

APPLICATIONS INFORMATION

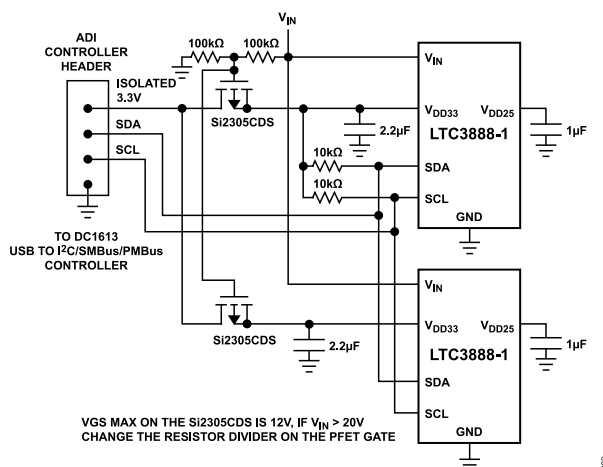

Figure 81. DC1613 Connections

The DC1613 I²C connections are opto-isolated from the host PC USB. The DC1613 3.3 V current limit is only 100 mA, so it should be used to power only one or two LTC3888 devices in-system. Because of this limited current sourcing capability, only the LTC3888 devices, their associated pull-up resistors and the I²C pull-up resistors should be powered from the isolated 3.3 V supply provided by the DC1613. Using the DC2086 will enable in-system programming of several tens of LTC3888 devices without normal system power applied. Some small current, normally less than 1 mA, may be driven back into the internal INTV_{CC} LDO output or V_{IN} supply by each LTC3888 when power is applied only to V_{DD33}.

Any other device sharing the I²C bus with the LTC3888 should not have internal body diodes between SDA/SCL pins and their respective logic supply, because this will interfere with bus communication in the absence of system power. Configure both masters to be off, for example by driving both RUN pins low, to avoid providing power to the load until the part is fully configured.

DESIGN EXAMPLE

As a design example, consider an LTC3888-1, 560 W dual output application such as the one shown in Figure 82, where V_{IN} = 12 V, V_{OUT0} = 1 V, and V_{OUT1} = 1.8 V. Both rails support a rated load of 200 A. The LTC7051 is chosen as the power stage for both rails based on its output current capability, feature set, and small package size. Assume that an auxiliary 5 V supply VDR will be available in the system for LTC7051 power requirements. Details are shown in Figure 82 for biasing and bypassing one of the power stages. This detail is not shown for the remaining seven LTC7051 devices but should be repeated for each (including V_{IN} bypass and output filter capacitance), with components located close to

each device using the PCB layout guidelines given in previous discussion.

The necessary local bypassing is then provided for the LTC3888-1 INTV_{CC} (4.7 μF), V_{DD33} (2.2 μF) and V_{DD25} (1 μF) LDO outputs. These LDO outputs should not be shared with outputs of other ICs that might have the same name, because they have independent internal control loops.

The PWM_CONFIG pin is left open to select the factory default master/slave configuration (4 + 4) and a PWM operating frequency (FREQUENCY_SWITCH) of 500 kHz, both of which are desired targets for this application. In this configuration the four phases of each rail are separated by 90°, and none of the eight phases overlap, producing the lowest input and output ripple possible.

The design will plan on a nominal output ripple of about 41% of I_{OUT} to minimize the magnetics volume, and the inductance value is chosen based on this assumption. Each phase supplies an average of 50 A to the output at full load, resulting in a ripple of 20 A_{p,p} in each choke. A 150 nH inductor would create this peak-to-peak ripple at 500 kHz on the 1.8 V rail. (Ripple on the 1 V rail will be less.) A Eaton FP1008R6-R150-R 150 nH inductor is selected with a 76 A saturation current limit at room temperature.

For input filtering, a bank of six 270 μF Panasonic OS_CON capacitors are selected to provide acceptable AC impedance against the designed converter ripple current. High frequency bypassing (1 Ω into 2.2 μF) is provided for the LTC3888-1 itself, and additional ceramic bulk bypass local to each power stage will also lower ESR on this input at higher frequencies.

APPLICATIONS INFORMATION

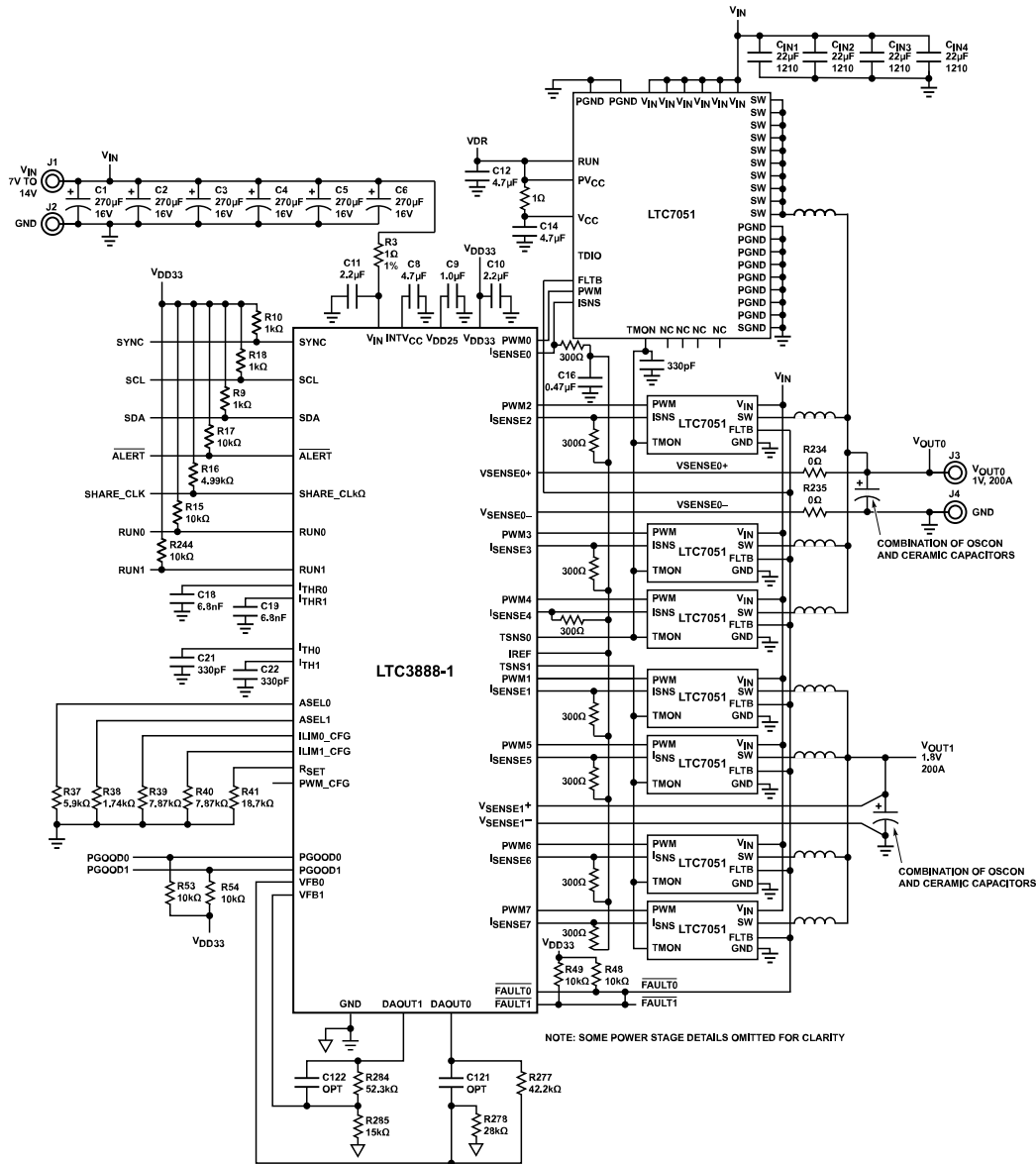

Figure 82. LTC3888-1 1 V/200 A and 1.8 V/200 A 500 kHz Converter using the LTC7051 DrMOS

APPLICATIONS INFORMATION

Four 470 μF Panasonic 5 m Ω POSCAPs and five 100 μF ceramic capacitors are chosen for each phase output to maintain supply regulation during severe transient conditions and to minimize output voltage ripple.

The loop compensation components C18, C21 ($V_{\text{OUT}0}$) and C19, C22 ($V_{\text{OUT}1}$) provide a good starting point to tune the crossover frequency by programming error amplifier transconductance and internal R_{TH} with the help of LTpowerCAD, LTpowerPlay and built-in LTC3888 load step emulation. With a 500 kHz switching frequency, an initial crossover target of 100 kHz should provide good transient performance. System phase margin of around 65° is recommended at that bandwidth.

For output current sensing, the LTC7051 provides a current-mode monitor scaled to 10 $\mu\text{A}/\text{A}$. The IREF output of the LTC3888-1 is used to provide the necessary common mode reference to all power stages. The current sensing resistor in between ISNS and IREF is 300 Ω , so current sensing gain is 3 mV/A. Each DrMOS device then has 470 nF of local bypassing on this DC reference (REFIN) to limit introduction of switching noise and crosstalk. These capacitors should be returned to GND (the LTC3888-1 package paddle) for best noise performance.

External temperatures of interest are also sensed by the individual power stages. The highest temperature for each rail is indicated on the shared TOUT/FLT bus, which is connected directly to the respective LTC3888-1 TSNS input.

The required R_{SET} resistor (18.7 k Ω) is connected to GND. Resistor configuration is then used on the ASEL0 and ASEL1 pins

to program PMBus address (MFR_ADDRESS) to 0x28. Each LTC3888-1 must be configured for a unique address. Using both ASEL pins to accomplish this is recommended for simplest in-system programming. Check the selected address to avoid collision with global addresses or other any other specific devices. The LTC3888-1 also responds to 7-bit global addresses 0x5A and 0x5B. MFR_ADDRESS and MFR_RAIL_ADDRESS should not be set to either of these values. Resistors are used to program ILIM0_CFG and ILIM1_CFG to set IOUT_OC_WARN_LIMIT to 52 A and IOUT_OC_FAULT_LIMIT to 65 A, based on the design value of 50 A rated load per phase (200 A total) with a room temperature choke saturation of 76 A.

PMBus connection (three signals), as well as shared RUN control and fault propagation (FAULT) for each rail are provided. SYNC can be used to synchronize other PWMs to this device if required. The SPI is connected using 4 pins. SCS must be routed individually to the master to select different LTC3888-1s in the application.

Pull-ups are provided on all open-drain signals assuming a maximum 100 pF line load and PMBus rate of 100 kHz. These pins should not be left floating. Termination to 3.3 V ensures the absolute maximum ratings for the pins are not exceeded. All other operating parameters such as soft-start/stop and desired fault responses are programmed via PMBus command values stored in internal LTC3888-1 EEPROM.

In the LTC3888-1, the output voltage is established by selecting suitable values for R284, R285 ($V_{\text{OUT}1}$), R277 and R278 ($V_{\text{OUT}0}$). Maintaining a total load on DAOUT in the range of 50 k Ω to 100 k Ω is recommended.

APPLICATIONS INFORMATION

TYPICAL APPLICATIONS

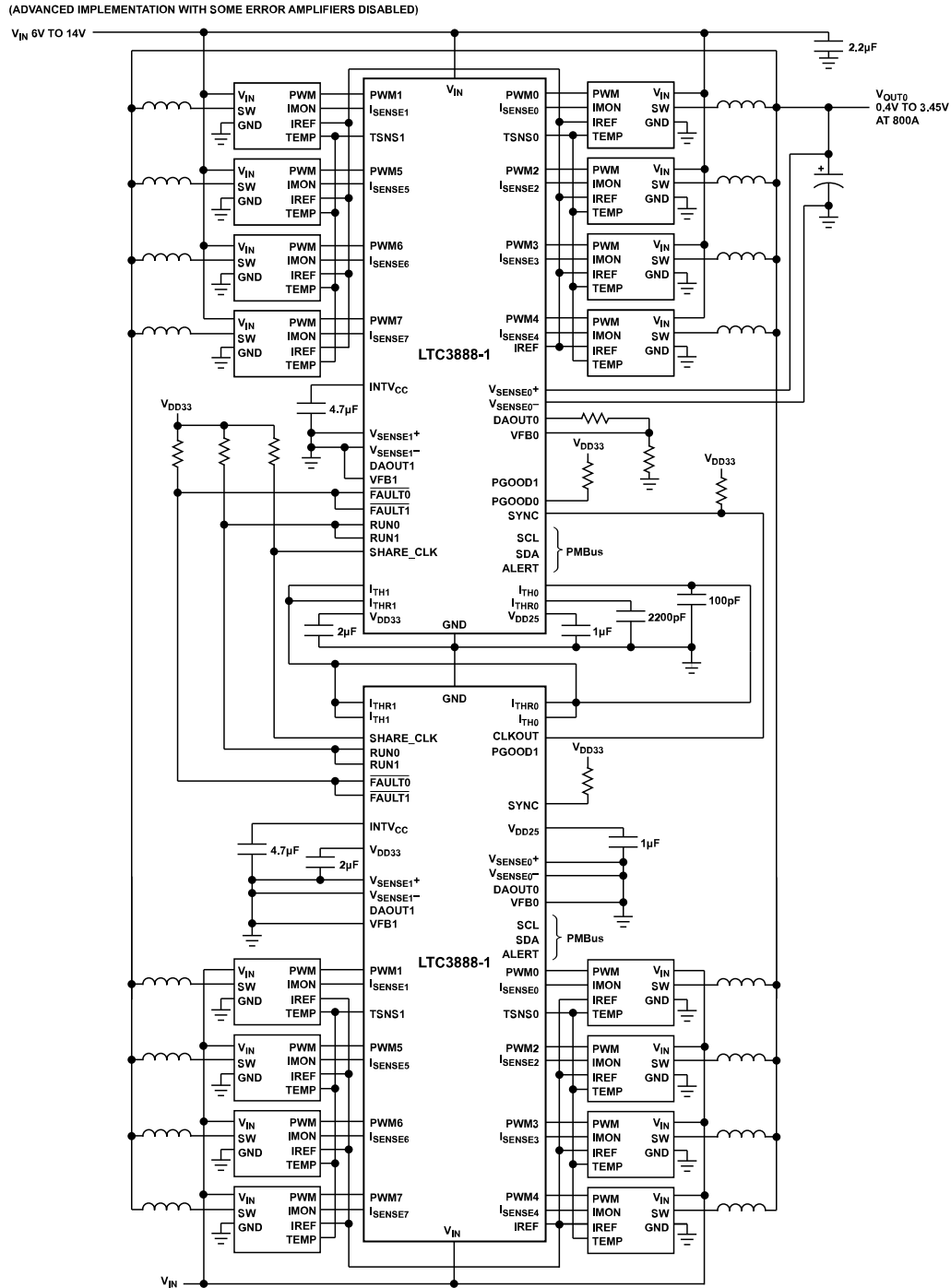

Figure 83. LTC3888-1 16-Phase 800 A Output, R_{SET} and Optional Resistor Configuration Not Shown, See Resistor Configuration Pins Section

APPLICATIONS INFORMATION

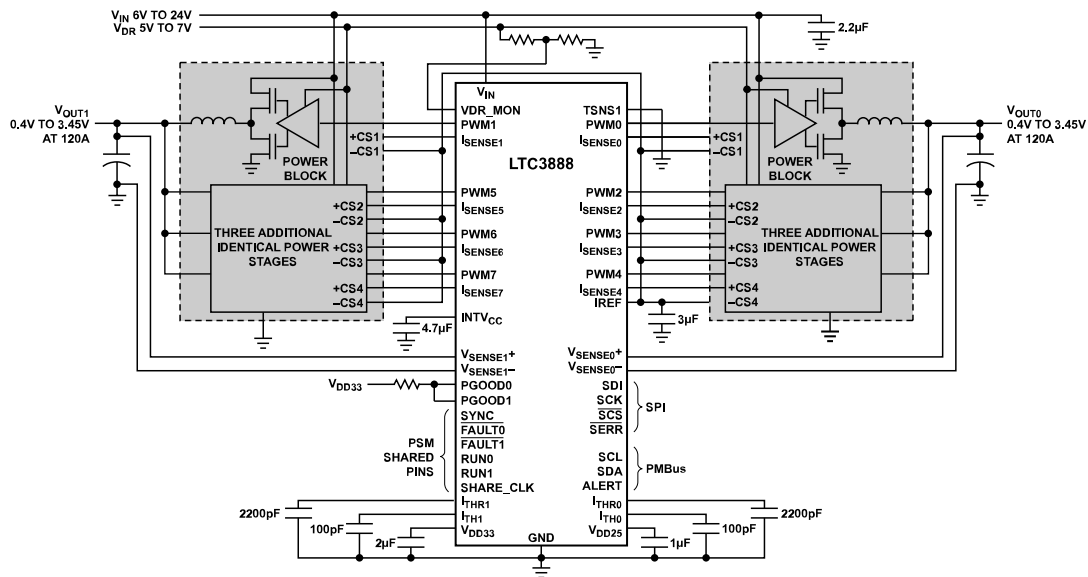

Figure 84. LTC3888 Dual 4-Phase 120 A Power Block Rails

Related Parts

PART NUMBER	DESCRIPTION	COMMENTS
LTM4676A	Dual 13 A or Single 26 A Step-Down DC/DC μ Module Regulator with Digital Power Management	V_{IN} Up to 26.5 V, $0.5 V \leq V_{OUT} (\pm 0.5\%) \leq 5.4 V$, $\pm 2\%$ I_{OUT} ADC Accuracy, Fault Logging, I^2C /PMBus Interface, 16mm \times 16mm \times 5mm BGA Package
LTM4677	Dual 18 A or Single 36 A Step-Down DC/DC μ Module Regulator with Digital Power System Management	$4.5 V \leq V_{IN} \leq 16 V$, $0.5 V \leq V_{OUT} (\pm 0.5\%) \leq 1.8 V$, I^2C /PMBus Interface, 16mm \times 16mm \times 5mm BGA Package
LTM4700	Dual 50 A or Single 100 A Step-Down DC/DC μ Module Regulator with Digital Power System Management	$4.5 V \leq V_{IN} \leq 16 V$, $0.5 V \leq V_{OUT} \leq 1.8 V$, $\pm 0.5\%$ V_{OUT} Accuracy, Fault Logging, I^2C /PMBus Interface, 15mm \times 22mm \times 7.87mm BGA Package
LTC2977	8-Channel PMBus Power System Manager	Fault Logging of 8 Output Voltages, V_{IN} and Die Temperature
LTC3882/LTC3882-1	Dual Output Multiphase Step-Down DC/DC Voltage Mode Controller Digital Power System Management	V_{IN} Up to 38 V, $0.5 V \leq V_{OUT} \leq 5.25 V$, $\pm 0.5\%$ V_{OUT} Accuracy, Fault Logging, I^2C /PMBus Interface with EEPROM and 16-Bit ADC
LTC3884/LTC3884-1	Dual Output Multiphase Step-Down DC/DC Current Mode Controller with Sub-m Ω DCR Sensing and Digital Power System Management	$4.5 V \leq V_{IN} \leq 38 V$, $0.5 V \leq V_{OUT} (\pm 0.5\%) \leq 5.5 V$, Fault Logging, I^2C /PMBus Interface with EEPROM and 16-Bit ADC, Programmable Analog Loop Compensation, Input Current Sense
LTC3874	Multiphase Step-Down DC/DC Current Mode Slave Controller with Sub-m Ω DCR Sensing	$4.5 V \leq V_{IN} \leq 38 V$, $0.5 V \leq V_{OUT}$ Up to 5.5 V, Accurate Current Sharing
LTC3887/LTC3887-1	Dual Output Multiphase Step-Down DC/DC Current Mode Controller Digital Power System Management	V_{IN} Up to 24 V, $0.5 V \leq V_{OUT} \leq 5.5 V$, $\pm 0.5\%$ V_{OUT} Accuracy, Fault Logging, I^2C /PMBus Interface with EEPROM and 16-Bit ADC
LTC3886	60 V Dual Output Multiphase Step-Down DC/DC Current Mode Controller Digital Power System Management	$4.5 V \leq V_{IN} \leq 60 V$, $0.5 V \leq V_{OUT} (\pm 0.5\%) \leq 13.8 V$, Fault Logging, I^2C /PMBus Interface with EEPROM and 16-Bit ADC, Programmable Analog Loop Compensation, Input Current Sense
LTC3889	60 V Dual Output Multiphase Step-Down DC/DC Current Mode Controller Digital Power System Management	$5 V \leq V_{IN} \leq 60 V$, $1 V \leq V_{OUT} \leq 40 V$, $\pm 0.5\%$ V_{OUT} Accuracy, Fault Logging, I^2C /PMBus Interface with EEPROM and 16-Bit ADC, Programmable Analog Loop Compensation, Input Current Sense

APPLICATIONS INFORMATION

PART NUMBER	DESCRIPTION	COMMENTS
LTC3870/LTC3870-1	60 V Multiphase Step-Down DC/DC Current Mode Slave Controller	V_{IN} Up to 60 V, $0.5\text{ V} \leq V_{OUT}$ Up to 14 V, Accurate Current Sharing

PMBUS COMMAND DETAILS

ADDRESSING AND WRITE PROTECT

Table 17. Addressing and Write Protect

COMMAND NAME	CMD CODE	DESCRIPTION	TYPE	PAGED	DATA FORMAT	UNITS	NVM	DEFAULT VALUE
PAGE	0x00	Channel (page) presently selected for any paged command.	R/W Byte	N	Reg			0x00
PAGE_PLUS_WRITE	0x05	Write a command directly to a specified page.	W Block	N				
PAGE_PLUS_READ	0x06	Read a command directly from a specified page.	Block R/W Process	N				
WRITE_PROTECT	0x10	Protect the device against unintended PMBus modifications.	R/W Byte	N	Reg		Yes	0x00
MFR_ADDRESS	0xE6	Specify right-justified 7-bit device address.	R/W Byte	N	Reg		Yes	0x4F
MFR_RAIL_ADDRESS	0xFA	Specify unique right-justified 7-bit address for channels comprising a PolyPhase output.	R/W Byte	Y	Reg		Yes	0x80

PAGE

The PAGE command provides the ability to configure, control and monitor both master channels through only one physical address, either the MFR_ADDRESS or global device address. Each PAGE contains the operating memory for one master channel.

Pages 0x00 and 0x01 correspond to Channel 0 (or PWM0) and Channel 1 (or PWM1), respectively.

Setting PAGE to 0xFF applies any following paged commands to both master channels. With PAGE set to 0xFF the LTC3888-1 will respond to read commands as if PAGE were set to 0x00 (Channel 0 results only).

This command has one data byte.

PAGE_PLUS_WRITE

The PAGE_PLUS_WRITE command provides a way to set the page within a device, send a command and then send the data for the command, all in one communication packet. Commands allowed by the present write protection level may be sent with PAGE_PLUS_WRITE.

The value stored in the PAGE command is not affected by PAGE_PLUS_WRITE. If PAGE_PLUS_WRITE is used to send a non-paged command, the Page Number byte is ignored.

This command uses Write Block protocol. An example of the PAGE_PLUS_WRITE command with PEC sending a command that has two data bytes is shown in Figure 85.

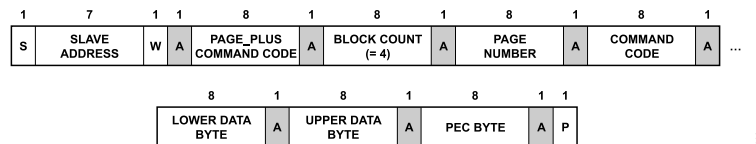

Figure 85. Example of PAGE_PLUS_WRITE

PAGE_PLUS_READ

The PAGE_PLUS_READ command provides the ability to set the page within a device, send a command and then read the data returned by the command, all in one communication packet.

The value stored in the PAGE command is not affected by PAGE_PLUS_READ. If PAGE_PLUS_READ is used to access data from a non-paged command, the Page Number byte is ignored.

This command uses Block Write – Block Read Process Call protocol. An example of the PAGE_PLUS_READ command with PEC is shown in Figure 86.

PMBUS COMMAND DETAILS

NOTE: PAGE_PLUS commands cannot be nested. A PAGE_PLUS command cannot be used to read or write another PAGE_PLUS command. If this is attempted, the LTC3888-1 will NACK the entire PAGE_PLUS packet and issue a CML fault for Invalid/Unsupported Data.

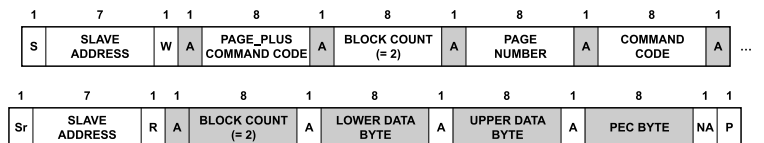

Figure 86. Example of PAGE_PLUS_READ

WRITE_PROTECT

The WRITE_PROTECT command is used to control PMBus write access to the LTC3888-1.

Table 18. Supported Values

VALUE	MEANING
0x80	Disable all writes except WRITE_PROTECT, PAGE, STORE_USER_ALL and MFR_EE_UNLOCK commands.
0x40	Disable all writes except WRITE_PROTECT, PAGE, STORE_USER_ALL, MFR_EE_UNLOCK, OPERATION, CLEAR_PEAKS and CLEAR_FAULTS commands. Individual faults can also be cleared by writing a 1 to the respective status bit.
0x20	Disable all writes except WRITE_PROTECT, PAGE, STORE_USER_ALL, MFR_EE_UNLOCK, OPERATION, CLEAR_PEAKS, CLEAR_FAULTS, ON_OFF_CONFIG and VOUT_COMMAND commands. Individual faults can be cleared by writing a 1 to the respective status bit.
0x00	Enables writes to all commands.

This command has one data byte.

MFR_ADDRESS

The MFR_ADDRESS command sets the seven bits of the PMBus device address for this unit.

Setting this command to a value of 0x80 disables device-level addressing. The global device addresses 0x5A and 0x5B cannot be disabled. The LTC3888-1 always responds at these addresses. The device address, or any portion of an address, specified with external resistors on ASEL0 or ASEL1 is applied. If both of these pins are open, the device address is determined strictly by the MFR_ADDRESS value stored in EEPROM. Refer to the [Theory of Operation](#) section on [Resistor Configuration Pins](#) section for additional details.

This command has one data byte.

MFR_RAIL_ADDRESS

The MFR_RAIL_ADDRESS command sets a direct PMBus address for the active channel(s) as determined by the PAGE command. This address should be common to all master channels attached to a single power supply rail. Setting this command to a value of 0x80 disables rail addressing for the selected channel. Only command writes should be made to the rail address. If a read is performed from this address, a CML fault may result.

This command has one data byte.

GENERAL DEVICE CONFIGURATION

Table 19. GENERAL DEVICE CONFIGURATION

COMMAND NAME	CMD CODE	DESCRIPTION	TYPE	PAGED	DATA FORMAT	UNITS	NVM	DEFAULT VALUE
PMBUS_REVISION	0x98	Supported PMBus version.	R Byte	Y	Reg			0x22V1.2
CAPABILITY	0x19	Summary of supported optional PMBus features.	R Byte	N	Reg			0xB0
MFR_CONFIG_ALL	0xD1	General device-level configuration.	R/W Byte	N	Reg		Yes	0x21

PMBUS COMMAND DETAILS

PMBUS_REVISION

The PMBUS_REVISION command returns the revision of the PMBus Specification that the device supports. The LTC3888-1 is compliant with PMBus Version 1.2, both Part I and Part II.

This read-only command has one data byte.

CAPABILITY

The CAPABILITY command reports some key LTC3888-1 features to the PMBus host device.

The LTC3888-1 supports packet error checking, 400 kHz bus speeds and has an $\overline{\text{ALERT}}$ output.

This read-only command has one data byte.

MFR_CONFIG_ALL

The MFR_CONFIG_ALL command provides device-level configuration common to multiple ADI PMBus products.

Table 20. Bit Definitions

BIT	MEANING
7	Enable fault logging.
6	Ignore resistor configuration pins.
5	Disable CML fault for quick command message.
4	Disable SYNC output.
3	Enable 255 ms PMBus timeout.
2	Require valid PEC for PMBus write.
1	Enable PMBus clock stretching.
0	Execute CLEAR_FAULTS when either channel is turned on by RUN pin or OPERATION command.

If a legal command is received with an invalid PEC, the LTC3888-1 will not execute the command, regardless of the state of bit 2. If clock stretching is enabled, the LTC3888-1 only uses it as required, generally above SCL rates of 100 kHz.

This command has one data byte.

ON, OFF AND MARGIN CONTROL

Table 21. ON, OFF AND MARGIN CONTROL

COMMAND NAME	CMD CODE	DESCRIPTION	TYPE	PAGED	DATA FORMAT	UNITS	NVM	DEFAULT VALUE
ON_OFF_CONFIG	0x02	RUN pin and PMBus on/off command configuration.	R/W Byte	Y	Reg		Yes	0x1E
OPERATION	0x01	On, off and margin control.	R/W Byte	Y	Reg		Yes	0x80
MFR_RESET	0xFD	Force full reset without removing power.	Send Byte	N				

ON_OFF_CONFIG

The ON_OFF_CONFIG command specifies the combination of RUN pin input state and PMBus commands needed to turn the addressed output rail on and off.

Table 22. Supported Values

VALUE	MEANING
0x1F	OPERATION value and RUN pin must both command the device to start/run. Device executes immediate off when commanded off.
0x1E	OPERATION value and RUN pin must both command the device to start/run. Device uses TOFF_ command values when commanded off.
0x17	RUN pin control with immediate off when commanded off. OPERATION on/off control ignored.
0x16	RUN pin control using TOFF_ command values when commanded off. OPERATION on/off control ignored.

PMBUS COMMAND DETAILS

Programming an unsupported ON_OFF_CONFIG value will generate a CML fault and the command will be ignored.

This command has one data byte.

OPERATION

The OPERATION command is used to turn the related output rail on and off in conjunction with RUN pin hardware control. This command may also be used to move the output voltage to margin levels. V_{OUT} changes commanded by OPERATION margin commands occur at the programmed VOUT_TRANSITION_RATE (LTC3888-1) TON_RISE (LTC3888/LTC3888-2). The unit stays in the commanded operating state until an OPERATION command or RUN pin voltage instructs the device to change to another state.

Execution of margin commands is delayed until any on-going output transition sequencing is completed. Margin operations that ignore faults are not supported by the LTC3888-1.

Table 23. Supported Values

VALUE	MEANING
0xA8	Margin high.
0x98	Margin low.
0x80	On (i.e. nominal V_{OUT} , even if bit 3 of ON_OFF_CONFIG is not set).
0x40 ¹	Soft off (with sequencing).
0x00 ¹	Immediate off (no sequencing).

¹ Device does not respond to these commands if bit 3 of ON_OFF_CONFIG is not set.

Programming an unsupported OPERATION value will generate a CML fault and the command will be ignored.

This command has one data byte.

MFR_RESET

This command provides a means to fully reset the LTC3888-1 from the PMBus. This forces the LTC3888-1 to turn off all PWM channels, load the operating memory from internal EEPROM, clear all faults and then perform a soft-start of all PWM channels that are enabled.

This write-only command has no data bytes.

PWM CONFIGURATION

Table 24. PWM CONFIGURATION

COMMAND NAME	CMD CODE	DESCRIPTION	TYPE	PAGED	DATA FORMAT	UNITS	NVM	DEFAULT VALUE
FREQUENCY_SWITCH	0x33	PWM frequency control.	R/W Word	N	L11	kHz	Yes	500 kHz 0xFBE8
MFR_CHAN_CONFIG	0xD0	General channel-specific configuration.	R/W Byte	Y	Reg		Yes	0x1D
MFR_PWM_CONFIG_LTC3888-1	0xF5	LTC3888-1 PWM configuration common to both master channels.	R/W Byte	N	Reg		Yes	0x03
MFR_PWM_MODE_LTC3888-1	0xD4	Channel-specific LTC3888-1 PWM mode control.	R/W Byte	Y	Reg		Yes	0x02
MFR_PWM_COMP	0xD3	Channel-specific PWM loop compensation	R/W Byte	Y	Reg		Yes	0xAE

FREQUENCY_SWITCH

The FREQUENCY_SWITCH command sets the switching frequency of all LTC3888-1 PWM channels in kilohertz. The valid range for this command value is 250 to 1000, inclusive. At most only one IC sharing SYNC should be programmed as clock master. See bit 4 in MFR_CONFIG_ALL. FREQUENCY_SWITCH value will determine the free-running frequency of PWM operation if an expected external clock source is not present or the bussed SYNC line becomes stuck due an external fault or conflict. Both master channels must be turned off by

PMBUS COMMAND DETAILS

the RUN pins, OPERATION command, or their combination to process this command. If this command is sent while either master channel is operating, the LTC3888-1 will NACK the command byte, ignore the command and its data, and assert a BUSY fault. A PLL Unlocked status may be reported after changing the value of this command until the new frequency is established.

This command has two data bytes in Linear_5s_11s format.

MFR_CHAN_CONFIG

The MFR_CHAN_CONFIG command provides per-channel configuration common to multiple ADI PMBus products.

Table 25. Bit Definitions

BIT	MEANING
7:6	(Reserved, must write as 0).
5	Pin 8 function control: (Page 0 only) 0: Pin 8 functions as TSNS0. 1: Pin 8 functions as VDR_MON.
4	RUN pin control: 0: When the channel is commanded off, the associated RUN pin is pulsed low for TOFF_DELAY + V _{OUT} /V _{OUT_TRANSITION_RATE} + 136 ms (LTC3888-1) or TOFF_DELAY + TOFF_FALL + 136ms (LTC3888/LTC3888-2) (or MFR_RESTART_DELAY, if longer) regardless of the state of bit 3. 1: RUN pin is not pulsed low if channel is commanded off.
3	Short cycle control: 0: No special control. Device attempts to follow on/off commands exactly as issued. 1: Output is immediately disabled if commanded back on while waiting for TOFF_DELAY or V _{OUT} /V _{OUT_TRANSITION_RATE} (LTC3888-1) or TOFF_FALL (LTC3888/LTC3888-2) to expire. A minimum off time of 120 ms is then enforced before the channel is turned back on. Additional delay will apply if bit 4 is clear.
2	SHARE_CLK output control:0: No special control.1: Output disabled if SHARE_CLK is held low.
1	(Reserved, must write as 0).
0	(Reserved, must write as 1).

This command has one data byte.

MFR_PWM_CONFIG_LTC3888

The MFR_PWM_CONFIG_LTC3888 command controls primary master/slave configuration and monitor ADC sampling control for the LTC3888. Both master channels must be turned off by the RUN pins, OPERATION command, or their combination to process this command. If this command is sent while either master channel is operating, the LTC3888 will NACK the command byte, ignore the command and its data, and assert a BUSY fault.

Table 26. Bit Definitions

BIT	MEANING
7	(Reserved, must write as 0)
6	Slave I _{OUT} Telemetry: 0: The LTC3888-1 provides continuous IOUT telemetry for all enabled phases. 1: The LTC3888-1 only provides IOUT telemetry for master channels PWM0 and PWM1.
5	SPI Logic Level (LTC3888 Only): 0: The LTC3888 SPI Interface uses SMBus 2.0 V Input Logic Levels. 1: The LTC3888 SPI Interface uses 1.8 V CMOS Input Logic Levels.
4	VOUT_OV_FAULT HW Response: 0: No special low level response, master phase obeys VOUT_OV_FAULT_RESPONSE of immediate off (PWM Hi-Z). 1: PWM of master phase driven low during VOUT_OV_FAULT, synchronous bottom power FET attempts to discharge V _{OUT} with rail off.
3	Phase Expansion: 0: The power-good state for Channel 0 is output on PGOOD0. 1: A phase expansion clock (CLKOUT) is output on PGOOD0 to drive SYNC on a second LTC3888-1.
[2:0]	Value Master/Slave Configuration

PMBUS COMMAND DETAILS

Table 26. Bit Definitions (Continued)

BIT	MEANING			
111	Master	Configuration/Slave	Phase (*)	
	PWM0	7-Phase	0	
	PWM0	PWM2	51.4	
	PWM0	PWM3	154.3	
	PWM0	PWM4	205.7	
	PWM0	PWM5	102.9	
	PWM0	PWM6	257.1	
	PWM0	PWM7	308.6	
110	PWM1	1-Phase	25.7	
	PWM0	(6-Phase)	0	
	PWM0	PWM2	60	
	PWM0	PWM3	180	
	PWM0	PWM4	240	
	PWM0	PWM5	120	
	PWM0	PWM6	300	
	PWM1	(2-Phase)	30	
101	PWM1	PWM7	210	
	PWM0	(6-Phase)	0	
	PWM0	PWM2	60	
	PWM0	PWM3	180	
	PWM0	PWM4	240	
	PWM0	PWM5	120	
	PWM0	PWM6	300	
	PWM1	(1-Phase)	30	
Value		PWM7	Off	
	Master/Slave Configuration			
[2:0]	Master	Configuration/Slave	Phase (*)	
	100	PWM0	(5-Phase)	0
		PWM0	PWM2	72
		PWM0	PWM3	144
		PWM0	PWM4	216
		PWM0	PWM5	288
		PWM1	(3-Phase)	34.3
		PWM1	PWM6	274.4
		PWM1	PWM7	154.3
	011	PWM0	(4-Phase, optional 8-phase with PWM1)	0
		PWM0	PWM2	90
		PWM0	PWM3	180
		PWM0	PWM4	270
		PWM1	(4-Phase, Optional 8-Phase with PWM0)	45
		PWM1	PWM5	135
		PWM1	PWM6	225
PWM1		PWM7	315	
010	PWM0	(4-Phase)	0	
	PWM0	PWM2	90	
	PWM0	PWM3	180	
	PWM0	PWM4	270	

PMBUS COMMAND DETAILS

Table 26. Bit Definitions (Continued)

BIT	MEANING		
001	PWM1	(3-Phase)	42.9
	PWM1	PWM5	162.9
	PWM1	PWM6	282.9
		PWM7	Off
	PWM0	(4-Phase)	0
	PWM0	PWM2	90
	PWM0	PWM3	180
000	PWM0	PWM4	270
	PWM1	(2-Phase)	45
		PWM5	Off
	PWM1	PWM6	225
		PWM7	Off
	PWM0	(3-Phase)	0
	PWM0	PWM2	120
	PWM3	Off	
	PWM0	PWM4	240
	PWM1	(3-Phase, Optional 6-Phase with PWM0)	60
	PWM1	PWM5	180
	PWM1	PWM6	300
		PWM7	Off

Phase is expressed from the falling edge of SYNC to the rising edge of PWM.

This command has one data byte.

MFR_PWM_MODE_LTC3888

The MFR_PWM_MODE_LTC3888 command sets important PWM controls for each master channel. The addressed channel(s) must be turned off by its RUN pin, OPERATION command, or their combination when this command is issued. Otherwise the LTC3888 will NACK the command byte, ignore the command and its data, and assert a BUSY fault.

This command has one data byte.

Table 27. Bit Definitions

BIT	MEANING
7	(Reserved)
6	Enable V _{OUT} servo. (V _{OUT_LOOP_SCALE} should be programmed first.)
5	(Reserved, must write as 0)
4	Error Amplifier Disable: 0: Error Amplifier output (I _{TH}) enabled. Channel operates as voltage loop master. 1: Error Amplifier output disabled (I _{TH} high-Z input). Channel operates as slave phase to another master.
3	V _{OUT} Supervisor Mode (LTC3888 Only): 0: UV and OV fault limits fixed at programmed values. 1: UV and OV fault limits move 1:1 with SPI-based V _{OUT} adjustment.
2	SPI Scale (LTC3888 Only): 0: LSB of SPI-based V _{OUT} adjustment is 5 mV. 1: LSB of SPI-based V _{OUT} adjustment is 10 mV.
1	t _{ON_MIN} Control: 0: Minimum PWM On Time Set by Controller (can be < 30 ns). 1: Minimum PWM On Time Limited to ≥ 30 ns.

PMBUS COMMAND DETAILS

Table 27. Bit Definitions (Continued)

BIT	MEANING
0	Power Stage UV HW Response: (see Applications Information for exceptions) 0: Rail ignores any UV indication on shared TEMP/FAULT bus. 1: Rail is latched off if UV is indicated on the shared TEMP/FAULT bus while operating. (WARNING: Not all power stages support this feature.)

MFR_PWM_COMP

The MFR_PWM_COMP command sets the transconductance of the voltage loop error amplifier and the value of the internal compensation resistor R_{TH} for each master channel.

Table 28. Bit Definitions

BIT	MEANING	
[7:5]	Value	Error Amplifier gm (mS)
	000b	1.00
	001b	1.68
	010b	2.35
	011b	3.02
	100b	3.69
	101b	4.36
	110b	5.04
	111b	5.73
[4:0]	Value	R_{TH} (kΩ)
	00000b	1
	00001b	1
	00010b	1
	00011b	1
	00100b	1
	00101b	1.25
	00110b	1.5
	00111b	1.75
	01000b	2
	01001b	2.5
	01010b	3
	01011b	3.5
	01100b	4
	01101b	4.5
	01110b	5
	01111b	5.5
	10000b	6
	10001b	7
	10010b	8
	10011b	9
	10100b	11
	10101b	13
	10110b	15
10111b	17	
11000b	20	
11001b	24	

PMBUS COMMAND DETAILS

Table 28. Bit Definitions (Continued)

BIT	MEANING	
	11010b	28
	11011b	32
	11100b	38
	11101b	46
	11110b	54
	11111b	62

This command has one data byte.

INPUT VOLTAGE AND LIMITS

Table 29. Input Voltage and Limits

COMMAND NAME	CMD CODE	DESCRIPTION	TYPE	PAGED	DATA FORMAT	UNITS	NVM	DEFAULT VALUE
VIN_ON	0x35	Minimum input voltage to begin power conversion.	R/W Word	N	L11	V	Yes	6.5 V 0xCB40
VIN_OFF	0x36	Decreasing input voltage at which power conversion stops.	R/W Word	N	L11	V	Yes	6.0 V 0xCB00
VIN_OV_FAULT_LIMIT	0x55	V _{IN} overvoltage fault limit.	R/W Word	N	L11	V	Yes	15.5 V 0xD3E0
VIN_UV_WARN_LIMIT	0x58	V _{IN} undervoltage warning limit.	R/W Word	N	L11	V	Yes	6.3 V 0xCB26

Related commands: STATUS_INPUT, SMBALERT_MASK, READ_VIN, VIN_OV_FAULT_RESPONSE

VIN_ON

The VIN_ON command sets the input voltage, in volts, required to start power conversion.

This command has two data bytes in Linear_5s_11s format.

VIN_OFF

The VIN_OFF command sets the minimum input voltage, in volts, at which power conversion stops.

This command has two data bytes in Linear_5s_11s format.

VIN_OV_FAULT_LIMIT

The VIN_OV_FAULT_LIMIT command sets the value of the input voltage measured by the ADC, in volts, that causes an input overvoltage fault.

This command has two data bytes in Linear_5s_11s format.

VIN_UV_WARN_LIMIT

The VIN_UV_WARN_LIMIT command sets the value of input voltage measured by the ADC, in volts, that causes an input undervoltage warning. This warning is disabled until the input exceeds the VIN_ON command value and the unit has been enabled. If the VIN_UV_WARN_LIMIT is then exceeded, the device:

- ▶ Sets the INPUT Bit in the STATUS_WORD
- ▶ Sets the V_{IN} Undervoltage Warning Bit in the STATUS_INPUT Command

PMBUS COMMAND DETAILS

- Notifies the Host by Asserting $\overline{\text{ALERT}}$, Unless Masked

OUTPUT VOLTAGE AND LIMITS

Table 30. OUTPUT VOLTAGE AND LIMITS (for PMBus Control, DEFAULT VALUE Applies to Analog Control)

COMMAND NAME	CMD CODE	DESCRIPTION	TYPE	PAGED	DATA FORMAT	UNITS	NVM	DEFAULT VALUE
VOUT_MODE	0x20	Output voltage format and exponent.	R Byte	Y	Reg			2 ⁻¹² 0x14
VOUT_COMMAND	0x21	Nominal output voltage setpoint for the LTC3888/LTC3888-2 and LTC3888-1 with VOUT_SCALE_LOOP defined. Otherwise nominal V _{FB} .	R/W Word	Y	L16	V	Yes	400 mV 0x0666
VOUT_MAX	0x24	Maximum V _{OUT} capability.	R Word	Y	L16	V		1.1 V (LTC3888-1) 0x119A 3.75 (LTC3888) 0x3C00
MFR_VOUT_MAX	0xA5	Maximum value allowed for VOUT_MAX.	R Word	Y	L16	V		3.75 V 0x3C00
VOUT_MARGIN_HIGH	0x25	Margin high voltage setpoint for the LTC3888/LTC3888-2 and LTC3888-1 with VOUT_SCALE_LOOP defined. Otherwise margin high V _{FB} .	R/W Word	Y	L16	V	Yes	420 mV 0x06B8
VOUT_MARGIN_LOW	0x26	Margin low voltage setpoint for the LTC3888/LTC3888-2 and LTC3888-1 with VOUT_SCAL_LOOP defined. Otherwise margin low V _{FB} .	R/W Word	Y	L16	V	Yes	380 mV 0x0614
VOUT_SCALE_LOOP (LTC3888-1)	0x29	Nominal V _{OUT} /V _{FB} gain provided by external feedback network.	R/W Word	Y	L11	V	Yes	N/A
VOUT_OV_FAULT_LIMIT	0x40	V _{OUT} overvoltage fault limit for the LTC3888/LTC3888-2 and LTC3888-1 with VOUT_SCALE_LOOP defined. Otherwise V _{OUT} over voltage V _{FB} .	R/W Word	Y	L16	V	Yes	440 mV 0x070A
VOUT_OV_WARN_LIMIT	0x42	V _{OUT} overvoltage warning limit sensed at V _{SENSE±} .	R/W Word	Y	L16	V	Yes	3.6- V 0x3981
VOUT_UV_WARN_LIMIT	0x43	V _{OUT} undervoltage warning limit sensed at V _{SENSE±} .	R/W Word	Y	L16	V	Yes	0.0 V 0x0000
VOUT_UV_FAULT_LIMIT	0x44	V _{OUT} undervoltage fault limit for the LTC3888/LTC3888-2 and LTC3888-1 with VOUT_SCALE_LOOP defined. Otherwise V _{OUT} under voltage V _{FB} .	R/W Word	Y	L16	V	Yes	360 mV 0x05C3
MFR_SPI_DATA	0xE8	Read SPI data as binary two's compliment. (LTC3888 Only)	R Byte	Y	CF			

Related commands: STATUS_VOUT, SMBALERT_MASK, READ_VOUT, MFR_VOUT_PEAK, VOUT_OV_FAULT_RESPONSE, VOUT_UV_FAULT_RESPONSE

VOUT_MODE

The VOUT_MODE command gives the format used by the device for output voltage related commands. Only Linear Mode is supported, with a resolution of 244 μ V. Sending the VOUT_MODE command to the LTC3888 using a write protocol will result in a CML fault.

This read-only command has one data byte.

PMBUS COMMAND DETAILS

VOUT_COMMAND

VOUT_COMMAND is used to set the output voltage in volts for the LTC3888/LTC3888-2 and the LTC3888-1 if VOUT_SCALE_LOOP is defined otherwise the voltage setpoint for V_{FB} . The maximum output voltage is 3.45. This command will not be acted upon if VOUT is ramping either due to soft on/off or margining.

This command has two data bytes in Linear_16u format.

VOUT_MAX

The VOUT_MAX command returns the maximum value, in volts, allowed for any V_{OUT} -related command, including VOUT_OV_FAULT_LIMIT. This value represents the maximum regulated voltage the selected rail is capable of producing based on internal design and the value of VOUT_SCALE_LOOP (LTC3888-1). It is fixed at 3.75 V in the LTC3888/LTC3888-2.

This read-only command has two data bytes in Linear_16u format.

MFR_VOUT_MAX

The MFR_VOUT_MAX command returns the maximum value, in volts, allowed for VOUT_MAX based on internal device capability.

This read-only command has two data bytes in Linear_16u format.

VOUT_MARGIN_HIGH

VOUT_MARGIN_HIGH command is used to set the margin high output voltage in volts for the LTC3888/LTC3888-2 and the LTC3888-1 if VOUT_SCALE_LOOP is defined, otherwise the margin high voltage sets V_{FB} . VOUT_MARGIN_HIGH must always be greater than VOUT.

This command has two data bytes in Linear_16u format.

VOUT_MARGIN_LOW

VOUT_MARGIN_LOW command is used to set the margin low output voltage in volts for the LTC3888/LTC3888-2 and the LTC3888-1 if VOUT_SCALE_LOOP is defined, otherwise the margin low voltage sets V_{FB} . VOUT_MARGIN_LOW must always be less than VOUT.

This command has two data bytes in Linear_16u format.

VOUT_SCALE_LOOP (LTC3888-1)

The VOUT_SCALE_LOOP command programs the gain, in volts per volt, produced from V_{FB} to V_{OUT} by the external voltage feedback network. Values from 1 to 9 are considered valid. The LTC3888-1 will assert a CML fault and ignore the value if an attempt is made to write VOUT_SCALE_LOOP to a value outside of this range or if the channel is on.

This command has two data bytes in Linear_5s_11s format.

VOUT_OV_FAULT_LIMIT

VOUT_OV_FAULT_LIMIT is the value in voltage the over voltage comparator triggers the LTC3888/LTC3888-2 and the LTC3888-1 if VOUT_SCALE_LOOP is defined. Otherwise, it the over voltage trigger for V_{FB} .

This command has two data bytes in Linear_16u format.

VOUT_OV_WARN_LIMIT

The VOUT_OV_WARN_LIMIT command sets the value, in volts, of the $V_{SENSE\pm}$ differential voltage measured by the ADC that causes an output overvoltage warning. If the VOUT_OV_WARN_LIMIT is exceeded, the device:

- ▶ Sets the V_{OUT} Bit in the STATUS_WORD

PMBUS COMMAND DETAILS

- ▶ Sets the V_{OUT} Overvoltage Warning Bit in the STATUS_VOUT Command
- ▶ Notifies the Host by Asserting \overline{ALERT} , Unless Masked

This command has two data bytes in Linear_16u format.

VOUT_UV_WARN_LIMIT

The VOUT_UV_WARN_LIMIT command sets the value, in volts, of the $V_{SENSE\pm}$ differential voltage measured by the ADC that causes an output undervoltage warning. If the VOUT_UV_WARN_LIMIT is exceeded, the device:

- ▶ Sets the VOUT Bit in the STATUS_WORD
- ▶ Sets the V_{OUT} Undervoltage Warning Bit in the STATUS_VOUT Command
- ▶ Notifies the Host by Asserting \overline{ALERT} , Unless Masked

This command has two data bytes in Linear_16u format.

VOUT_UV_FAULT_LIMIT

VOUT_UV_FAULT_LIMIT is the value in voltage the under voltage comparator triggers the LTC3888/LTC3888-2 and the LTC3888-1 if VOUT_SCALE_LOOP is defined. Otherwise, it the under voltage trigger for V_{FB} .

This command has two data bytes in Linear_16u format.

MFR_SPI_DATA (LTC3888)

The MFR_SPI_DATA command returns the existing VOUT offset code programmed by the Serial Peripheral Interface for each master channel. Refer to the [Serial Peripheral Interface \(LTC3888 Only\)](#) section in the [Theory of Operation](#) section for complete details.

This read-only command has one data byte in Linear_16u format.

OUTPUT CURRENT AND LIMITS

Table 31. OUTPUT CURRENT AND LIMITS

COMMAND NAME	CMD CODE	DESCRIPTION	TYPE	PAGED	DATA FORMAT	UNITS	NVM	DEFAULT VALUE
IOUT_CAL_GAIN	0x38	Ratio of I_{SENSE} voltage to sensed current.	R/W Word	Y	L11	m Ω	Yes	5 m Ω 0xCA80
MFR_LOAD_EMULATION	0xF7	Load step emulation control.	R/W Byte	Y	Reg			0x00
IOUT_OC_FAULT_LIMIT	0x46	Per phase output overcurrent fault limit.	R/W Word	Y	L11	A	Yes	29.75 A 0xDBB8
IOUT_OC_WARN_LIMIT	0x4A	Per phase output overcurrent warning limit.	R/W Word	Y	L11	A	Yes	20.0 A 0xDA80

Related commands: STATUS_IOUT, SMBALERT_MASK, READ_IOUT, MFR_IOUT_PEAK, MFR_TOTAL_IOUT, MFR_READ_ALL_IOUT, IOUT_OC_FAULT_RESPONSE

IOUT_CAL_GAIN

The IOUT_CAL_GAIN command is used to set the power stage output current monitor gain at I_{SENSE} in milliohms. If both master channels are not commanded off by their RUN pin or OPERATION command when IOUT_CAL_GAIN is sent to either page, the LTC3888-1 will assert a CML fault.

This command has two data bytes in Linear_5s_11s format.

PMBUS COMMAND DETAILS

MFR_LOAD_EMULATION

The MFR_LOAD_EMULATION command is used to control load step emulation for all phases on each master channel.

Table 32. MFR_LOAD_EMULATION

BIT	MEANING	
7	(Reserved)	
6	(Reserved)	
5	(Reserved)	
4	(Reserved)	
3	Enable Load Step Emulation (LSE) Event Scope Trigger on PGOOD (negative edge)	
2	LSE Mode Control: 0: Non-pulsed: LSE state statically follows data written to bits[1:0]. 1: Pulsed: Writing any non-zero state to bits [1:0] produces an LSE pulse of the specified magnitude with a width of ~ 100 μ s.	
[1:0]	Value	Load Step Emulated at IOUT_CAL_GAIN = 5 mΩ
	11b	30A/Phase
	10b	20A/Phase
	01b	10A/Phase
	00b	Off

This command has one data byte.

IOUT_OC_FAULT_LIMIT

The IOUT_OC_FAULT_LIMIT command sets the value of the per phase output current, in amperes, which will cause the OC supervisor to detect an output overcurrent fault. The LTC3888-1 uses IOUT_CAL_GAIN and the voltage between the I_{SENSE} inputs and IREF to determine output current. Output overcurrent faults are ignored during turn-on and turn-off output transitions.

This command has two data bytes in Linear_5s_11s format.

IOUT_OC_WARN_LIMIT

The IOUT_OC_WARN_LIMIT command sets the value of the average per phase output current measured by the ADC, in amperes, that causes an output overcurrent warning. To provide meaningful responses, this value should be set below IOUT_OC_FAULT_LIMIT. If the IOUT_OC_WARN_LIMIT is exceeded, the device:

- ▶ Sets the I_{OUT} Bit in the STATUS_WORD
- ▶ Sets the I_{OUT} Overcurrent Warning Bit in the STATUS_IOUT Command
- ▶ Notifies the Host by Asserting ALERT, Unless Masked

Output overcurrent warnings are ignored during turn-on and turn-off output transitions.

This command has two data bytes in Linear_5s_11s format.

OUTPUT TIMING, DELAYS, AND RAMPING

Table 33. Output Timing, Delays, and Ramping

COMMAND NAME	CMD CODE	DESCRIPTION	TYPE	PAGED	DATA FORMAT	UNITS	NVM	DEFAULT VALUE
MFR_RESTART_DELAY	0xDC	Minimum time RUN pin is held low by the LTC3888.	R/W Word	Y	L11	ms	Yes	500 ms 0xFBE8
TON_DELAY	0x60	Delay from RUN pin or OPERATION on command to beginning of soft-start ramp.	R/W Word	Y	L11	ms	Yes	0.0 ms 0x8000

PMBUS COMMAND DETAILS

Table 33. Output Timing, Delays, and Ramping (Continued)

COMMAND NAME	CMD CODE	DESCRIPTION	TYPE	PAGED	DATA FORMAT	UNITS	NVM	DEFAULT VALUE
TON_RISE (LTC3888 Only)	0x61	Time for V_{OUT} to rise from 0 V to final value after TON_DELAY.	R/W Word	Y	L11	ms	Yes	8.0 ms 0xD200
TON_MAX_FAULT_LIMIT	0x62	Maximum time for V_{OUT} to rise above VOUT_UV_FAULT_LIMIT after TON_DELAY.	R/W Word	Y	L11	ms	Yes	10.0 ms 0xD280
VOUT_TRANSITION_RATE	0x27	Slew rate control for VOUT command and margining. Additionally in the LTC3888-1, slew rate for soft on/off and V_{FB} for default parts.	R/W Word	Y	L11	V/ms	Yes	0.01 0x82BF
TOFF_DELAY	0x64	Delay from RUN pin or OPERATION off command to beginning of soft-off ramp.	R/W Word	Y	L11	ms	Yes	0.0 ms 0x8000
TOFF_FALL (LTC3888 Only)	0x65	Time for V_{OUT} to fall to 0 V after TOFF_DELAY.	R/W Word	Y	L11	ms	Yes	8.0 ms 0xD200
TOFF_MAX_WARN_LIMIT	0x66	Maximum time for V_{OUT} to reach 0.125xVOUT_COMMAND after being commanded to 0.0 V.	R/W Word	Y	L11	ms	Yes	0.0 ms 0x8000

Related commands: MFR_RETRY_DELAY, STATUS_VOUT, SMBALERT_MASK, TON_MAX_FAULT_RESPONSE

These commands can be used to establish required sequencing and tracking for any number of system power supply rails.

MFR_RESTART_DELAY

The MFR_RESTART_DELAY command specifies the minimum rail off time (RUN low) in milliseconds. The LTC3888 will actively hold its RUN pin low for this length of time if a falling RUN edge is detected. After this delay, a standard start-up sequence can be initiated. A minimum of TOFF_DELAY + TOFF_FALL + 136 ms is recommended for this command value. Valid value range is 136 ms to 65.52 seconds. The LTC3888-1 will not produce delays outside of this range and uses a resolution of 16 ms for this command.

This command has two data bytes in Linear_5s_11s format.

TON_DELAY

The TON_DELAY command sets the delay, in milliseconds, between a PWM start condition and the beginning of the output voltage rise. Values from 0 ms to 83 seconds are considered valid, and the LTC3888-1 will not produce delays outside of this range.

This command has two data bytes in Linear_5s_11s format.

TON_RISE (LTC3888)

The TON_RISE command set the desired time, in milliseconds, from the point the output starts to rise until it reaches regulation. Values from 0 to 1.3 seconds are valid, and the LTC3888 will not produce rise times outside this range. Values of TON_RISE less than 0.25 ms will result in the output commanded to the programmed voltage in 1 step, the actual TON_RISE of the system is limited by the PWM analog loop and the power stage.

This command has two data bytes in Linear_5s_11s format.

TON_MAX_FAULT_LIMIT

In the LTC3888/LTC3888-2, TON_MAX_FAULT > TON_RISE. In the LTC3888-1 TON_MAX_FAULT_LIMIT > 1.25xVOUT_COMMAND/VOUT_TRANSITION_RATE. The TON_MAX_FAULT_LIMIT command sets the maximum time, in milliseconds, the unit is allowed from the beginning of the soft-start ramp to power up the output without passing VOUT_UV_FAULT_LIMIT. A value of 0 ms means there is no limit and the unit can attempt to bring up the output voltage indefinitely. The maximum allowed TON_MAX is 8 seconds. To avoid generation of spurious faults, the value of this command should be set to meet the following guideline.

This command has two data bytes in Linear_5s_11s format.

PMBUS COMMAND DETAILS

VOUT_TRANSITION_RATE

The VOUT_TRANSITION_RATE command sets the rate at which VOUT changes as VOUT is commanded to a new value or the margin commands are executed. If VOUT_SCALE_LOOP (LTC3888-1) is not set, then VOUT_TRANSITION_RATE is the rate at which V_{FB} changes. In the LTC3888-1 the VOUT_TRANSITION_RATE also controls the VOUT rate of change during soft on and soft off. The LTC3888/LTC3888-2 use TON_RISE and TOFF_FALL during soft on and soft off respectively.

This command has two data bytes in Linear_5s_11s format.

TOFF_DELAY

The TOFF_DELAY command sets the delay, in milliseconds, between a stop condition and the beginning of the output voltage fall. Values from 0s to 16s are considered valid.

This command has two data bytes in Linear_5s_11s format.

TOFF_FALL (LTC3888)

The TOFF_FALL command set the desired time, in milliseconds, from the end of TOFF_DELAY until the output voltage is commanded fully to zero. The part attempts to linearly reduce the regulated output voltage to zero during TOFF_FALL. At the end of this period the output rail is disabled. Values from 0 to 1.3 seconds are valid. Programmed values less than 0.25 ms this will result in a commanded step to zero. The TOFF_FALL slope will be limited by the PWM analog loop response and the power stage.

This command has two data bytes in Linear_5s_11s format.

TOFF_MAX_WARN_LIMIT

The TOFF_MAX_WARN_LIMIT command sets the time, in milliseconds, V_{OUT} is allowed to drop to $0.125 \times V_{OUT_COMMAND}$ after being commanded to 0 V. This time begins after TOFF_DELAY+VOUT_COMMAND/VOUT_TRANSITION (LTC3888-1) or TOFF_DELAY + TOFF_FALL (LTC3888/LTC3888-2) expires if the output is not commanded to immediate off. If this limit is exceeded a warning is issued in VOUT_STATUS and ALERT asserted if not masked. No warning limit is enforced the value of this command is programmed to zero. Otherwise, values from 120 ms to 524 s are considered valid. In order to avoid erroneous ALERT indication, in the LTC3888-1 VOUT_SCALE_LOOP and all other related V_{OUT} commands must be defined before this command is set to a non-zero value.

This command has two data bytes in Linear_5s_11s format.

EXTERNAL TEMPERATURE AND LIMITS

Table 34. EXTERNAL TEMPERATURE AND LIMITS

COMMAND NAME	CMD CODE	DESCRIPTION	TYPE	PAGED	DATA FORMAT	UNITS	NVM	DEFAULT VALUE
MFR_TEMP_1_GAIN	0xF8	Slope for external temperature calculations.	R/W Word	Y	L11	mV/°C	Yes	8 mV/°C 0xD200
MFR_TEMP_1_OFFSET	0xF9	0°C offset for external temperature calculations.	R/W Word	Y	L11	mV	Yes	600 mV 0x0258
OT_FAULT_LIMIT	0x4F	External overtemperature fault limit.	R/W Word	Y	L11	°C	Yes	100.0°C 0xEB20
OT_WARN_LIMIT	0x51	External overtemperature warning limit.	R/W Word	Y	L11	°C	Yes	85.0°C 0xEAA8

Related commands: STATUS_TEMPERATURE, SMBALERT_MASK, READ_TEMPERATURE_1, MFR_TEMPERATURE1_PEAK, OT_FAULT_RESPONSE

PMBUS COMMAND DETAILS

MFR_TEMP_1_GAIN

The MFR_TEMP_1_GAIN command sets the slope, in mV/°C, used in the calculation of external temperature based on monitor ADC conversions of the shared TEMP/FAULT bus (TSNS pins).

This command has two data bytes in Linear_5s_11s format.

MFR_TEMP_1_OFFSET

The MFR_TEMP_1_OFFSET command sets the 0°C offset, in mV, used in the calculation of external temperature based on monitor ADC conversions of the shared TEMP/FAULT bus (TSNS pins).

This command has two data bytes in Linear_5s_11s format.

OT_FAULT_LIMIT

The OT_FAULT_LIMIT command sets the value of sensed external temperature, in degrees Celsius, which causes an overtemperature fault.

This command has two data bytes in Linear_5s_11s format.

OT_WARN_LIMIT

The OT_WARN_LIMIT command sets the value of sensed external temperature, in degrees Celsius, which causes an overtemperature warning. If the OT_WARN_LIMIT is exceeded, the device:

- ▶ Sets the TEMPERATURE Bit in the STATUS_BYTE
- ▶ Sets the Overtemperature Warning Bit in the STATUS_TEMPERATURE Command
- ▶ Notifies the Host by Asserting $\overline{\text{ALERT}}$, Unless Masked

This command has two data bytes in Linear_5s_11s format.

STATUS REPORTING

Table 35. STATUS REPORTING

COMMAND NAME	CMD CODE	DESCRIPTION	TYPE	PAGED	DATA FORMAT	UNITS	NVM	DEFAULT VALUE
STATUS_BYTE	0x78	One-byte channel status summary.	R/W Byte	Y	Reg			
STATUS_WORD	0x79	Two-byte channel status summary.	R/W Word	Y	Reg			
STATUS_VOUT	0x7A	V _{OUT} fault and warning status.	R/W Byte	Y	Reg			
STATUS_IOUT	0x7B	I _{OUT} fault and warning status.	R/W Byte	Y	Reg			
STATUS_INPUT	0x7C	Input supply fault and warning status.	R/W Byte	N	Reg			
STATUS_TEMPERATURE	0x7D	External temperature fault and warning status.	R/W Byte	Y	Reg			
STATUS_CML	0x7E	Communication, memory and logic fault and warning status.	R/W Byte	N	Reg			
STATUS_MFR_SPECIFIC	0x80	IC-specific status.	R/W Byte	Y	Reg			
MFR_PADS_LTC3888-1	0xE5	State of selected LTC3888-1 pads.	R Word	N	Reg			
MFR_COMMON	0xEF	ADI-generic device status reporting.	R Byte	N	Reg			
MFR_INFO	0xB6	Manufacturer-specific information	R Word	N	Reg			
CLEAR_FAULTS	0x03	Clear all set fault bits.	Send Byte	N				

Refer to [Figure 36](#) for a graphical depiction of these register contents and their relationships. Refer to [Power Stage Selection and Interface](#) section in the [Applications Information](#) section for details of special status reporting related to external power stages that is supported by the LTC3888-1.

PMBUS COMMAND DETAILS

STATUS_BYTE

The STATUS_BYTE command returns a one-byte summary of the most critical faults.

Table 36. STATUS_BYTE Message Contents

BIT	STATUS BIT NAME	MEANING
7 ¹	BUSY	A fault was declared because the device was unable to respond.
6	OFF	This bit is set if the channel is not providing power to its output, regardless of the reason, including simply not being enabled.
5	VOUT_OV	An output overvoltage or power stage fault has occurred. Also set if open V _{SENSE+} is detected.
4	IOUT_OC	An output overcurrent fault has occurred.
3	VIN_UV	Not supported (device returns 0).
2	TEMPERATURE	A temperature fault or warning has occurred.
1	CML	A communications, memory or logic fault has occurred.
0	NONE OF THE ABOVE	A fault Not listed in bits[7:1] has occurred.

¹ $\overline{\text{ALERT}}$ can be asserted if this bit is set. It may be cleared by writing a 1 to that bit position in the STATUS_BYTE, in lieu of a CLEAR_FAULTS command.

This command has one data byte.

STATUS_WORD

The STATUS_WORD command returns a two-byte summary of the channel's fault condition. The low byte of the STATUS_WORD is the same as the STATUS_BYTE command.

Table 37. STATUS_WORD High Byte Message Contents

BIT	STATUS BIT NAME	MEANING
15	VOUT	An output voltage fault or warning has occurred. Also set if a power stage fault or open V _{SENSE+} is detected.
14	IOUT	An output current fault or warning has occurred. Also set if a power stage fault is detected.
13	INPUT	An input voltage fault or warning has occurred.
12	MFR_SPECIFIC	A fault or warning specific to the LTC3888-1 has occurred.
11	POWER_GOOD#	The POWER_GOOD state is false if this bit is set.
10	FANS	Not supported (LTC3888-1 returns 0).
9	OTHER	Not supported (LTC3888-1 returns 0).
8	UNKNOWN	Not supported (LTC3888-1 returns 0).

This command has two data bytes.

STATUS_VOUT

The STATUS_VOUT command returns one byte of V_{OUT} status information. Refer to [Table 12](#) for additional details.

Table 38. STATUS_VOUT Message Contents

BIT	MEANING
7	V _{OUT} overvoltage fault, power stage fault, or open V _{SENSE+} input.
6	V _{OUT} overvoltage warning.
5	V _{OUT} undervoltage warning.
4	V _{OUT} undervoltage fault or open V _{SENSE+} input.
3	VOUT_MAX warning.
2	TON_MAX fault.
1	Not supported by the LTC3888-1 (returns 0).

PMBUS COMMAND DETAILS

Table 38. STATUS_VOUT Message Contents (Continued)

BIT	MEANING
0	Not supported by the LTC3888-1 (returns 0).

$\overline{\text{ALERT}}$ can be asserted if any of bits[7:2] are set. These may be cleared by writing a 1 to their bit position in STATUS_VOUT, in lieu of a CLEAR_FAULTS command.

This command has one data byte.

STATUS_IOUT

The STATUS_IOUT command returns one byte of I_{OUT} status information. Refer to [Table 12](#) for additional details.

Table 39. STATUS_IOUT Message Contents

BIT	MEANING
7	I _{OUT} overcurrent fault.
6	Not supported (LTC3888-1 returns 0).
5	I _{OUT} overcurrent warning.
4	Not supported (LTC3888-1 returns 0).
3	Power stage fault detected (differs from standard PMBus meaning).
2:0	Not supported (LTC3888-1 returns 0).

$\overline{\text{ALERT}}$ can be asserted if any supported bits are set. Any supported bit may be cleared by writing a 1 to that bit position in STATUS_IOUT, in lieu of a CLEAR_FAULTS command.

This command has one data byte.

STATUS_INPUT

The STATUS_INPUT command returns one byte of V_{IN} status information.

Table 40. STATUS_INPUT Message Contents

BIT	MEANING
7	V _{IN} overvoltage fault.
6	Not supported (LTC3888-1 returns 0).
5	V _{IN} undervoltage warning.
4	Not supported (LTC3888-1 returns 0).
3	Unit off for insufficient V _{IN} .
2:0	Not supported (LTC3888-1 returns 0).

$\overline{\text{ALERT}}$ can be asserted if bit 7 is set. Bit 7 may be cleared by writing it to a 1, in lieu of a CLEAR_FAULTS command.

This command has one data byte.

STATUS_TEMPERATURE

The STATUS_TEMPERATURE command returns one byte of sensed external temperature status information.

Table 41. STATUS_TEMPERATURE Message Contents

BIT	MEANING
7	External overtemperature fault.
6	External overtemperature warning.
5	Not supported (LTC3888-1 returns 0).
4	Not supported (LTC3888-1 returns 0).

PMBUS COMMAND DETAILS

Table 41. STATUS_TEMPERATURE Message Contents (Continued)

BIT	MEANING
3:0	Not supported (LTC3888-1 returns 0).

$\overline{\text{ALERT}}$ can be asserted if any supported bits are set. Any supported bit may be cleared by writing a 1 to that bit position in STATUS_TEMPERATURE, in lieu of a CLEAR_FAULTS command.

This command has one data byte.

STATUS_CML

The STATUS_CML command returns one byte of status information on received commands, internal memory and logic.

Table 42. STATUS_CML Message Contents

BIT	MEANING
7	Invalid or unsupported command received.
6	Invalid or unsupported data received.
5	Packet error check failed.
4	Memory fault detected.
3	Processor fault detected.
2	Reserved (LTC3888-1 returns 0).
1	Other communication fault.
0	Other memory or logic fault.

$\overline{\text{ALERT}}$ can be asserted if any supported bits are set. Any supported bit may be cleared by writing a 1 to that bit position in STATUS_CML, in lieu of a CLEAR_FAULTS command.

This command has one data byte.

STATUS_MFR_SPECIFIC

The STATUS_MFR_SPECIFIC command returns one byte with device-specific status information.

Table 43. STATUS_MFR_SPECIFIC Message Contents

BIT	MEANING
7	Internal temperature fault (>160°C).
6	Internal temperature warning (>130°C).
5	EEPROM CRC error.
4	Internal PLL unlocked.
3	Fault log present.
2	Not supported (LTC3888-1 returns 0).
1	Output short cycled.
0	FAULT low.

If any supported bits are set, the MFR bit in the STATUS_WORD will be set and $\overline{\text{ALERT}}$ may be asserted. Any supported bit may be cleared by writing a 1 to that bit position in STATUS_MFR_SPECIFIC, in lieu of a CLEAR_FAULTS command.

This command has one data byte.

MFR_PADS_LTC3888-1

The MFR_PADS_LTC3888-1 command provides status of the LTC3888-1 digital I/O and control pins, in addition to general output voltage conditions.

PMBUS COMMAND DETAILS

Table 44. MFR_PADS_LTC3888-2 Message Contents

BIT	MEANING
15	Channel 1 power stages all report ready.
14	Channel 0 power stages all report ready.
13:12	Not supported (LTC3888-1 returns 0).
11	ADC results for READ_TEMPERATURE_1 may be invalid.
10	SYNC output disabled externally.
9	Channel 1 POWER_GOOD.
8	Channel 0 POWER_GOOD.
7	LTC3888-1 forcing RUN1 low.
6	LTC3888-1 forcing RUN0 low.
5	RUN1 pin state.
4	RUN0 pin state.
3	LTC3888-1 forcing FAULT1 low.
2	LTC3888-1 forcing FAULT0 low.
1	FAULT1 pin state.
0	FAULT0 pin state.

This read-only command has two data bytes.

MFR_COMMON

The MFR_COMMON command contains status bits that are common to multiple ADI PMBus products.

Table 45. MFR_COMMON Message Contents

BIT	MEANING
7	LTC3888-1 not forcing ALERT low.
6	LTC3888-1 not BUSY.
5	LTC3888-1 calculations not pending.
4	LTC3888-1 output not in transition.
3	LTC3888-1 EEPROM initialized.
2	Not supported (LTC3888-1 returns 0).
1	SHARE_CLK timeout.
0	Not supported (LTC3888-1 returns 0).

This read-only command has one data byte.

MFR_INFO

The MFR_INFO command contains status bits providing manufacturer-specific information.

Table 46. MFR_INFO Message Contents

BIT	MEANING
15:6	Reserved.
5	EEPROM ECC Status: 0: Corrections have been made in the EEPROM user space. 1: No corrections have been made in the EEPROM user space.
4:0	Reserved.

This read-only command has two data bytes.

PMBUS COMMAND DETAILS

CLEAR_FAULTS

The CLEAR_FAULTS command clears any fault bits that have been set and deasserts (releases) the $\overline{\text{ALERT}}$ pin. This command clears all fault bits in all status commands simultaneously.

CLEAR_FAULTS does not cause a channel that has latched off for a fault condition to restart. Channels that are latched off for a fault condition are restarted when the output is commanded to turn off and then on through the OPERATION command or RUN pins, or IC supply power is cycled.

If a fault is still present when CLEAR_FAULTS is commanded, that fault bit will immediately be set again and $\overline{\text{ALERT}}$ asserted low if not masked.

This write-only command has no data bytes.

TELEMETRY

Table 47. TELEMETRY

COMMAND NAME	CMD CODE	DESCRIPTION	TYPE	PAGED	DATA FORMAT	UNITS	NVM	DEFAULT VALUE
READ_VIN	0x88	Measured V_{IN} .	R Word	N	L11	V		
MFR_VIN_PEAK	0xDE	Maximum V_{IN} measurement since last MFR_CLEAR_PEAKS.	R Word	N	L11	V		
READ_VOUT	0x8B	Measured V_{OUT} .	R Word	Y	L16	V		
MFR_VOUT_PEAK	0xDD	Maximum V_{OUT} measurement since last MFR_CLEAR_PEAKS.	R Word	Y	L16	V		
READ_IOUT	0x8C	Measured master channel I_{OUT} .	R Word	Y	L11	A		
MFR_IOUT_PEAK	0xD7	Maximum master channel I_{OUT} measurement since last MFR_CLEAR_PEAKS.	R Word	Y	L11	A		
MFR_TOTAL_IOUT	0xE1	Measured total I_{OUT} for each rail defined by MFR_PWM_CONFIG_LTC3888-1.	R Word	Y	L11	A		
MFR_READ_ALL_IOUT	0xE4	Measured I_{OUT} for each individual PWM phase.	R Block	N	L11	A		
READ_TEMPERATURE_1	0x8D	Measured external temperature.	R Word	Y	L11	°C		
MFR_TEMPERATURE_1_PEAK	0xDF	Maximum external temperature measurement since last MFR_CLEAR_PEAKS.	R Word	Y	L11	°C		
READ_TEMPERATURE_2	0x8E	Measured internal temperature.	R Word	N	L11	°C		
MFR_TEMPERATURE_2_PEAK	0xF4	Maximum internal temperature measurement since last MFR_CLEAR_PEAKS.	R Word	N	L11	°C		
READ_FREQUENCY	0x95	Measured PWM input clock frequency.	R Word	Y	L11	kHz		
MFR_CLEAR_PEAKS	0xE3	Clear all peak values.	Send Byte	N				

Related Commands: IOUT_CAL_GAIN

READ_VIN

The READ_VIN command returns the input voltage measured between V_{IN} and GND in volts.

This read-only command has two data bytes in Linear_5s_11s format.

MFR_VIN_PEAK

The MFR_VIN_PEAK command reports the highest voltage, in volts, measured for READ_VIN. This peak value can be reset by a MFR_CLEAR_PEAKS command.

This read-only command has two data bytes in Linear_5s_11s format.

PMBUS COMMAND DETAILS

READ_VOUT

The READ_VOUT command returns the output voltage measured at the $V_{SENSE\pm}$ pins in volts.

This read-only command has two data bytes in Linear_16u format.

MFR_VOUT_PEAK

The MFR_VOUT_PEAK command reports the highest voltage, in volts, measured for READ_VOUT. This peak value can be reset by a MFR_CLEAR_PEAKS command.

This read-only command has two data bytes in Linear_16u format.

READ_IOUT

The READ_IOUT command returns the master channel output current in amperes. This value is computed by applying IOUT_CAL_GAIN to the voltage measured between I_{SENSE} and IREF.

This read-only command has two data bytes in Linear_5s_11s format.

MFR_IOUT_PEAK

The MFR_IOUT_PEAK command reports the highest current, in amperes, calculated for READ_IOUT. This peak value can be reset by a MFR_CLEAR_PEAKS command.

This read-only command has two data bytes in Linear_5s_11s format.

MFR_TOTAL_IOUT

The MFR_TOTAL_IOUT command reports the total output current for all on-chip phases of the entire rail as defined by MFR_PWM_CONFIG_LTC3888-1. The value is calculated from the sum of the individual phase I_{OUT} ADC conversions. If bit 6 of MFR_PWM_CONFIG_LTC3888-1 is set, PWM2-PWM7 report 0A regardless of the actual output load. Sums are always reported by page, even if the master channel has been defined as a slave (see bit 4 of MFR_PWM_MODE_LTC3888-1). Sums across IC boundaries are not supported.

This read-only command has two data bytes in Linear_5s_11s format.

MFR_READ_ALL_IOUT

The MFR_READ_ALL_IOUT command reports the output current for each of the eight phases on the LTC3888-1 using block read protocol. Monitor ADC results are presented in order from PWM0 to PWM7. If bit 6 of MFR_PWM_CONFIG_LTC3888-1 is set, PWM2-PWM7 report 0A.

This read-only command uses block protocol with 17 bytes of data delivering I_{OUT} results in Linear_5s_11s format.

READ_TEMPERATURE_1

The READ_TEMPERATURE_1 command returns the temperature, in degrees Celsius, of external power stages connected to the device TSNS pin(s).

This read-only command has two data bytes in Linear_5s_11s format.

MFR_TEMPERATURE_1_PEAK

The MFR_TEMPERATURE_1_PEAK command reports the highest temperature, in degrees Celsius, calculated for READ_TEMPERATURE_1. This peak value can be reset by a MFR_CLEAR_PEAKS command.

This read-only command has two data bytes in Linear_5s_11s format.

PMBUS COMMAND DETAILS

READ_TEMPERATURE_2

The READ_TEMPERATURE_2 command returns the LTC3888-1 internal temperature in degrees Celsius.

This read-only command has two data bytes in Linear_5s_11s format.

MFR_TEMPERATURE_2_PEAK

The MFR_TEMPERATURE_2_PEAK command reports the highest temperature, in degrees Celsius, calculated for READ_TEMPERATURE_2. This peak value can be reset by a MFR_CLEAR_PEAKS command.

This read-only command has two data bytes in Linear_5s_11s format.

READ_FREQUENCY

The READ_FREQUENCY command returns the switching frequency supplied to the internal PLL in kilohertz, whether generated internally or provided by external clock on the SYNC pin.

This read-only command has two data bytes in Linear_5s_11s format.

MFR_CLEAR_PEAKS

The MFR_CLEAR_PEAKS command resets all stored _PEAK values. The LTC3888-1 determines new peak values after this command is received.

This write-only command has no data bytes.

FAULT RESPONSE AND COMMUNICATION

Table 48. FAULT RESPONSE AND COMMUNICATION

COMMAND NAME	CMD CODE	DESCRIPTION	TYPE	PAGED	DATA FORMAT	UNITS	NVM	DEFAULT VALUE
VIN_OV_FAULT_RESPONSE	0x56	V _{IN} overvoltage fault response.	R/W Byte	Y	Reg		Yes	0x80
VOV_OV_FAULT_RESPONSE	0x41	V _{OUT} overvoltage fault response.	R Byte	Y	Reg		Yes	0x80
VOV_UV_FAULT_RESPONSE	0x45	V _{OUT} undervoltage fault response.	R/W Byte	Y	Reg		Yes	0xB8
IOV_OC_FAULT_RESPONSE	0x47	Output overcurrent fault response.	R/W Byte	Y	Reg		Yes	0x00
OT_FAULT_RESPONSE	0x50	External overtemperature fault response.	R/W Byte	Y	Reg		Yes	0xB8
MFR_OT_FAULT_RESPONSE	0xD6	Internal overtemperature fault response.	R Byte	N	Reg		Yes	0xC0
TON_MAX_FAULT_RESPONSE	0x63	Fault response when TON_MAX_FAULT_LIMIT is exceeded.	R/W Byte	Y	Reg		Yes	0xB8
MFR_RETRY_DELAY	0xDB	Minimum time before retry after a fault.	R/W Word	N	L11	ms	Yes	350 ms 0xFABC
SMBALERT_MASK	0x1B	Mask $\overline{\text{ALERT}}$ Activity.	Block R/W	Y	Reg		Yes	See Following Details
MFR_FAULT_PROPAGATE	0xD2	Configure fault propagation via $\overline{\text{FAULT}}$ pins.	R/W Word	Y	Reg		Yes	0x6993
MFR_FAULT_RESPONSE	0xD5	PWM response when $\overline{\text{FAULT}}$ pin is low due to external fault.	R/W Byte	Y	Reg		Yes	0xC0
MFR_FAULT_LOG	0xEE	Read fault log data.	R Block	N	Reg			
MFR_FAULT_LOG_CLEAR	0xEC	Clear existing EEPROM fault log.	Send Byte	N				

Related commands: STATUS_BYTE, STATUS_WORD, MFR_PADS_LTC3888-1, MFR_RESTART_DELAY, MFR_FAULT_LOG_STORE, CLEAR_FAULTS

PMBUS COMMAND DETAILS

These commands detail programmable device responses for detected faults beyond the hardware-level actions described in the [Theory of Operation](#) section. LTC3888-1 hardware-level fault responses cannot be modified. PMBus warning event responses are listed under `_WARN_LIMIT` command details.

VIN_OV_FAULT_RESPONSE

The `VIN_OV_FAULT_RESPONSE` command instructs the device on what action to take in response to an input overvoltage fault. The format for this command is given in [Table 52](#). The device also:

- ▶ Sets the INPUT Bit in the STATUS_WORD
- ▶ Sets the V_{IN} Overvoltage Fault Bit in the STATUS_INPUT Command
- ▶ Notifies the Host by Asserting $\overline{\text{ALERT}}$, Unless Masked

This command has one data byte.

VOUT_OV_FAULT_RESPONSE

The `VOUT_OV_FAULT_RESPONSE` command reports the actions the device will take in response to an output overvoltage fault, power stage fault or qualified UVLO or qualified VDR supply UV during operation. The format for this command is given in [Table 49](#). The device also:

- ▶ Sets the VOUT_OV Bit in the STATUS_BYTE
- ▶ Sets the VOUT Bit in the STATUS_WORD
- ▶ Sets the V_{OUT} Overvoltage Fault Bit in the STATUS_VOUT Command
- ▶ Notifies the Host by Asserting $\overline{\text{ALERT}}$, Unless Masked

This read-only command has one data byte.

VOUT_UV_FAULT_RESPONSE

The `VOUT_UV_FAULT_RESPONSE` command instructs the device on what action to take in response to an output undervoltage fault. The format for this command is given in [Table 49](#). The device also:

- ▶ Sets the VOUT Bit in the STATUS_WORD
- ▶ Sets the V_{OUT} Undervoltage Fault Bit in the STATUS_VOUT Command,
- ▶ Notifies the Host by Asserting $\overline{\text{ALERT}}$, Unless Masked

This command has one data byte.

Table 49. Data Byte Contents for `VOUT_OV_FAULT_RESPONSE` and `VOUT_UV_FAULT_RESPONSE`

BITS	DESCRIPTION	VALUE	MEANING
[7:6]	For all values of bits [7:6], the LTC3888-1: <ul style="list-style-type: none"> ▶ Sets the corresponding fault bits in the status commands. ▶ Notifies the host by asserting ALERT, unless masked. The fault, once set, is cleared only when one or more of the following events occurs: <ul style="list-style-type: none"> ▶ The device receives a CLEAR_FAULTS command. ▶ The corresponding STATUS_VOUT bit is written to a one. ▶ The output is commanded off, then on, by the RUN pin or OPERATION command. ▶ The device receives a RESTORE_USER_ALL command. ▶ The device receives an MFR_RESET command. ▶ IC supply power is cycled. 	00	The LTC3888-1 continues to operate indefinitely with the normal hardware response described in the Theory of Operation section.
		01	The LTC3888-1 continues operating with the normal hardware response for the delay time specified by bits [2:0]. If the fault is continuously present for the entire delay, the unit then disables the output and responds according to the retry setting in bits [5:3].
		10	The LTC3888-1 immediately disables the output and responds according to the retry setting in bits [5:3].
		11	Not supported. Writing this value will generate a CML fault.

PMBUS COMMAND DETAILS

Table 49. Data Byte Contents for VOUT_OV_FAULT_RESPONSE and VOUT_UV_FAULT_RESPONSE (Continued)

BITS	DESCRIPTION	VALUE	MEANING
[5:3]	Retry setting.	000-110	The LTC3888-1 does not attempt to restart. The output remains disabled until the fault is cleared, the device is commanded off and then on, or IC supply power is cycled.
		111	The LTC3888-1 attempts to restart continuously without limitation with an interval set by MFR_RETRY_DELAY. This response persists until the unit is commanded off, or IC supply power is removed, or another fault response forces shutdown without retry.
[2:0]	Delay time.	xxx	Response delay time in 10 μ s increments. This delay time determines how long the fault may have to persist before the controller is disabled, depending on bits [7:6]. Hardware-level response, if any, will occur during this delay.

IOUT_OC_FAULT_RESPONSE

The IOUT_OC_FAULT_RESPONSE command instructs the device on what action to take in response to an output overcurrent fault. The device also:

- ▶ Sets the IOUT_OC Bit in the STATUS_BYTE
- ▶ Sets the IOUT Bit in the STATUS_WORD
- ▶ Sets the I_{OUT} Overcurrent Fault Bit in the STATUS_IOUT Command
- ▶ Notifies the Host by Asserting $\overline{\text{ALERT}}$, Unless Masked

Output overcurrent faults are ignored during turn-on and turn-off output transitions.

Table 50. Data Byte Contents for IOUT_OC_FAULT_RESPONSE

BITS	DESCRIPTION	VALUE	MEANING
[7:6]	For all values of bits [7:6], the LTC3888-1: <ul style="list-style-type: none"> ▶ Sets the corresponding fault bits in the status commands. ▶ Notifies the host by asserting $\overline{\text{ALERT}}$, unless masked. The fault, once set, is cleared only when one or more of the following events occurs: <ul style="list-style-type: none"> ▶ The device receives a CLEAR_FAULTS command. ▶ The corresponding STATUS_IOUT bit is written to a one. ▶ The output is commanded off, then on, by the RUN pin or OPERATION command. ▶ The device receives a RESTORE_USER_ALL command. ▶ The device receives an MFR_RESET command. ▶ IC supply power is cycled. 	00	The LTC3888-1 continues to operate indefinitely with the normal hardware response described in the Theory of Operation section.
		01	Not supported. Writing this value will generate a CML fault.
		10	The LTC3888-1 continues operating with the normal hardware response for the delay time specified by bits [2:0]. If the fault is continuously present for the entire delay, the unit then disables the output and responds according to the retry setting in bits [5:3].
		11	The LTC3888-1 immediately disables the output and responds according to the retry setting in bits [5:3].
[5:3]	Retry setting.	000-110	The LTC3888-1 does not attempt to restart. The output remains disabled until the fault is cleared, the device is commanded off and then on, or IC supply power is cycled.
		111	The LTC3888-1 attempts to restart continuously without limitation with an interval set by MFR_RETRY_DELAY. This response persists until the unit is commanded off, IC supply power is removed, or another fault response forces shutdown without retry.
[2:0]	Delay time.	xxx	Response delay time in 16ms increments. This delay time determines how long the fault may have to persist before the controller is disabled, depending on bits [7:6]. These bits always return zero if bits [7:6] is 00 or 11.

This command has one data byte.

PMBUS COMMAND DETAILS

OT_FAULT_RESPONSE

The OT_FAULT_RESPONSE command instructs the device on what action to take in response to an external overtemperature fault. The format for this command is given in Table 52. The device also:

- ▶ Sets the TEMPERATURE Bit in the STATUS_BYTE
- ▶ Sets the Overtemperature Fault Bit in the STATUS_TEMPERATURE Command
- ▶ Notifies the Host by Asserting $\overline{\text{ALERT}}$, Unless Masked

This command has one data byte.

MFR_OT_FAULT_RESPONSE

The MFR_OT_FAULT_RESPONSE command instructs the device on what action to take in response to an internal overtemperature fault (150°C to 160°C). The device also:

- ▶ Sets the MFR Bit in the STATUS_WORD
- ▶ Sets the Overtemperature Fault Bit in the STATUS_MFR_SPECIFIC Command
- ▶ Notifies the Host by Asserting $\overline{\text{ALERT}}$, Unless Masked

Table 51. Supported Values

VALUE	MEANING
0xC0	The LTC3888 disables when the die temperature exceeds 160°C and restarts when the die temperature drops below 150°C.

This command is read only.

This command has one data byte.

TON_MAX_FAULT_RESPONSE

The TON_MAX_FAULT_RESPONSE command instructs the device on what action to take in response to a TON_MAX fault. The format for this command is given in Table 52. The device also:

- ▶ Sets the VOUT Bit in the STATUS_WORD
- ▶ Sets the TON_MAX Fault Bit in the STATUS_VOUT Command
- ▶ Notifies the Host by Asserting $\overline{\text{ALERT}}$, Unless Masked

This command has one data byte.

Table 52. Data Byte Contents for the Following_FAULT_RESPONSE Commands: VIN_OV, OT and TON_MAX

BITS	DESCRIPTION	VALUE	MEANING
[7:6]	For all values of bits [7:6], the LTC3888-1: <ul style="list-style-type: none"> ▶ Sets the corresponding fault bits in the status commands. ▶ Notifies the host by asserting ALERT, unless masked. The fault, once set, is cleared only when one or more of the following events occurs: <ul style="list-style-type: none"> ▶ The device receives a CLEAR_FAULTS command. ▶ The corresponding fault bit is written to a one. ▶ The output is commanded off, then on, by the RUN pin or OPERATION command. ▶ The device receives a RESTORE_USER_ALL command. ▶ The device receives an MFR_RESET command. 	00	The LTC3888-1 continues operating without interruption.
		01	Not supported. Writing this value will generate a CML fault.
		10	The LTC3888-1 shuts down immediately (disables the output) and responds according to the retry setting in bits [5:3].
		11	Not supported. Writing this value will generate a CML fault.

PMBUS COMMAND DETAILS

Table 52. Data Byte Contents for the Following `_FAULT_RESPONSE` Commands: `VIN_OV`, `OT` and `TON_MAX` (Continued)

BITS	DESCRIPTION	VALUE	MEANING
	▶ IC supply power is cycled.		
[5:3]	Retry setting.	000-110	The LTC3888-1 does not attempt to restart. The output remains disabled until the fault is cleared, the device is commanded off and then on, or IC supply power is cycled.
		111	The LTC3888-1 attempts to restart continuously without limitation with an interval set by <code>MFR_RETRY_DELAY</code> . This response persists until the unit is commanded off, IC supply power is removed, or another fault response forces shutdown without retry.
[2:0]	Delay time.	xxx	Not supported. Values ignored.

MFR_RETRY_DELAY

The `MFR_RETRY_DELAY` command sets the time, in milliseconds, between restart attempts for all retry fault responses. Retry delay starts once the fault is no longer detected by the LTC3888-1 or its `FAULT` pin is externally released. Legal values run from 120 ms to 83 seconds.

This command has two data bytes in `Linear_5s_11s` format.

SMBALERT_MASK

The `SMBALERT_MASK` command can be used to prevent a particular status bit or bits from pulling `ALERT` low as they are asserted.

[Figure 87](#) shows an example of the Write Word format used to set an `ALERT` mask, in this case without PEC. The bits in the mask byte align with bits in the specified status register. For example, if the `STATUS_TEMPERATURE` command code is sent in the first data byte, and the mask byte contains `0x40`, then a subsequent External Overtemperature Warning would still set bit 6 of `STATUS_TEMPERATURE` but not assert `ALERT`. All other supported `STATUS_TEMPERATURE` bits would continue to assert `ALERT` if set.

[Figure 88](#) shows an example of the Block Write — Block Read Process Call protocol used to read back the present state of the `ALERT` mask for any supported status register, again without PEC.

`SMBALERT_MASK` cannot be applied to `STATUS_BYTE`, `STATUS_WORD`, `MFR_COMMON` or `MFR_PADS_LTC3888-1`. Factory default masking for applicable status registers is shown below. Providing an unsupported command code to `SMBALERT_MASK` will generate a CML for Invalid/Unsupported Data.

Table 53. `SMBALERT_MASK` Default Setting: (Refer Also to [Figure 36](#))

STATUS REGISTER	ALERT Mask Value	MASKED BITS
<code>STATUS_VOUT</code>	0x00	None
<code>STATUS_IOUT</code>	0x00	None
<code>STATUS_TEMPERATURE</code>	0x00	None
<code>STATUS_CML</code>	0x00	None
<code>STATUS_INPUT</code>	0x00	None
<code>STATUS_MFR_SPECIFIC</code>	0x11	Bit 4 (internal PLL unlocked), bit 0 (<code>FAULT</code> low)

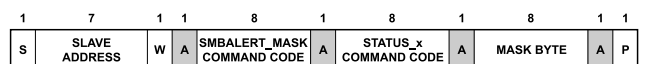

Figure 87. Example of Setting `SMBALERT_MASK`

PMBUS COMMAND DETAILS

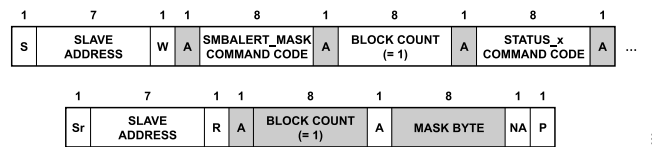

Figure 88. Example of Reading SMBALERT_MASK

MFR_FAULT_PROPAGATE

The MFR_FAULT_PROPAGATE command determines internal events that cause $\overline{\text{FAULT}}$ to be asserted. Setting a bit in this register allows the specified condition to also assert the $\overline{\text{FAULT}}$ output for that channel. $\overline{\text{FAULT}}$ is not asserted by a fault, even if set to propagate, if that FAULT_RESPONSE is set to Ignore. The state of SMBALERT_MASK does not affect fault propagation.

Table 54. Supported Values

BIT	PROPAGATED CONDITION
15	(Reserved).
14	V_{OUT} short cycled (automatically deasserted 120 ms after V_{OUT} is fully OFF).
13	TON_MAX_FAULT_LIMIT exceeded.
12	VOUT_UV_FAULT_LIMIT exceeded (unfiltered, aka VOUT_UV_UF).
11	MFR_OT_FAULT_LIMIT exceeded.
10	(Reserved).
9	(Reserved).
8	(Reserved).
7	OT_FAULT_LIMIT exceeded.
6	(Reserved).
5	(Reserved).
4	VIN_OV_FAULT_LIMIT exceeded.
3	(Reserved).
2	IOUT_OC_FAULT_LIMIT exceeded.
1	VOUT_UV_FAULT_LIMIT exceeded
0	VOUT_OV_FAULT_LIMIT exceeded, power stage fault or UV, or VDR monitor UV

This command has two data bytes.

MFR_FAULT_RESPONSE

The MFR_FAULT_RESPONSE command instructs the device on what action to take in response to a $\overline{\text{FAULT}}$ pin being pulled low externally.

Table 55. Supported Values

VALUE	MEANING
0xC0	Related rail is immediately disabled.
0x00	Input ignored, PWM operation continues without interruption.

When a $\overline{\text{FAULT}}$ pin is pulled low externally, the device also:

- ▶ Sets the MFR_SPECIFIC Bit in the STATUS_WORD
- ▶ Sets Bit 0 in the STATUS_MFR_SPECIFIC Command to Indicate $\overline{\text{FAULT}}$ Is or Has Been Pulled Low
- ▶ Notifies the Host by Asserting $\overline{\text{ALERT}}$, Unless Masked

This command has one data byte.

PMBUS COMMAND DETAILS

MFR_FAULT_LOG

The MFR_FAULT_LOG command allows the contents of the fault log to be read. This log is created with MFR_FAULT_LOG_STORE or at the first fault occurrence after an MFR_FAULT_LOG_CLEAR. If a fault occurs within the first second after applying power, some earlier pages in the log may not contain valid data.

This read-only command uses block protocol with 147 bytes of data requiring an estimated data transfer time of 3.4 ms at 400 kHz. The t_{TIMEOUT} parameter is extended when this command is executed and a fault log is present.

Refer to [Fault Log Details](#) section in the [Theory of Operation](#) section for complete information on using the LTC3888-1 fault log.

MFR_FAULT_LOG_CLEAR

The MFR_FAULT_LOG_CLEAR command erases all stored fault log values. After a clear is issued, up to 8 ms may be required to clear related bit 3 in STATUS_MFR_SPECIFIC.

This write-only command has no data bytes.

EEPROM USER ACCESS

Table 56. EEPROM User Access

COMMAND NAME	CMD CODE	DESCRIPTION	TYPE	PAGED	DATA FORMAT	UNITS	NVM	DEFAULT VALUE
STORE_USER_ALL	0x15	Store entire operating memory in EEPROM.	Send Byte	N				
RESTORE_USER_ALL	0x16	Restore entire operating memory from EEPROM.	Send Byte	N				
MFR_COMPARE_USER_ALL	0xF0	Compare operating memory with EEPROM contents.	Send Byte	N				
MFR_FAULT_LOG_STORE	0xEA	Force capture of fault log in RAM and transfer to EEPROM.	Send Byte	N				
MFR_EE_UNLOCK	0xBD	(contact the factory)						
MFR_EE_ERASE	0xBE	(contact the factory)						
MFR_EE_DATA	0xBF	(contact the factory)						
USER_DATA_00	0xB0	EEPROM word reserved for LTpowerPlay.	R/W Word	N	Reg		Yes	
USER_DATA_01	0xB1	EEPROM word reserved for LTpowerPlay.	R/W Word	Y	Reg		Yes	
USER_DATA_02	0xB2	EEPROM word reserved for OEM use.	R/W Word	N	Reg		Yes	
USER_DATA_03	0xB3	EEPROM word available for general data storage.	R/W Word	Y	Reg		Yes	0x0000
USER_DATA_04	0xB4	EEPROM word available for general data storage.	R/W Word	N	Reg		Yes	0x0000

Related commands: MFR_CONFIG_ALL

Note that if the LTC3888-1 die temperature exceeds 130°C, execution of any command in the above table except RESTORE_USER_ALL and MFR_FAULT_LOG_STORE will be disabled until the IC temperature drops below 125°C. RESTORE_USER_ALL is executed immediately, and MFR_FAULT_LOG_STORE to EEPROM is executed after the IC temperature drops below 125°C. Using any command that writes data to the EEPROM is strongly discouraged if bit 6 of STATUS_MFR_SPECIFIC is set, indicating the internal die temperature is above 85°C. Data retention of 10 years is not guaranteed if the EEPROM is written above a junction temperature of 85°C.

STORE_USER_ALL

The STORE_USER_ALL command instructs the PMBus device to copy the entire contents of the operating memory to internal EEPROM PMBus configuration space.

This write-only command has no data bytes.

PMBUS COMMAND DETAILS**RESTORE_USER_ALL**

The RESTORE_USER_ALL command instructs the PMBus device to copy the entire contents of the internal EEPROM to matching locations in operating memory. The values in operating memory are overwritten by the values retrieved from EEPROM. Both master channels should be turned off prior to issuing this command. The LTC3888-1 ensures all PWM channels are off, loads the operating memory from internal EEPROM, clears all faults, reads the resistor configuration pins, and then performs a soft-start of any enabled master channels.

This write-only command has no data bytes.

MFR_COMPARE_USER_ALL

The MFR_COMPARE_USER_ALL command instructs the LTC3888-1 to compare current operating memory with the contents of the internal EEPROM. If the compared memories differ, a CML fault is generated.

This write-only command has no data bytes.

MFR_FAULT_LOG_STORE

The MFR_FAULT_LOG_STORE command forces a data log to be written to RAM (at any temperature) and transferred to internal EEPROM as if a fault event had occurred. Execution of this command will lock the fault log until a subsequent MFR_FAULT_LOG_CLEAR is received. Die temperature limitations apply to the EEPROM write, as noted above. This command will generate a CML fault if the Enable Fault Logging bit is clear in MFR_CONFIG_ALL.

This write-only command has no data bytes.

MFR_EE_xxxx

The MFR_EE_xxxx commands facilitate bulk programming of the LTC3888-1 internal EEPROM. Contact the factory for details.

USER_DATA_0x

The USER_DATA_0x commands provide uncommitted EEPROM locations that may be applied as system scratchpad space. USER_DATA_00 and USER_DATA_01 should not be modified when using the LTpowerPlay GUI. Some contract manufacturers also reserve use of USER_DATA_02 for their own inventory control.

UNIT IDENTIFICATION

Table 57. UNIT IDENTIFICATION

COMMAND NAME	CMD CODE	DESCRIPTION	TYPE	PAGED	DATA FORMAT	UNITS	NVM	DEFAULT VALUE
MFR_ID	0x99	Manufacturer identification.	R String	N	ASC			LTC
IC_DEVICE_ID	0xAD	Model number.	R String	N	ASC			LTC3888 LTC3888-1
MFR_SPECIAL_ID	0xE7	Unique manufacturer product ID	R Word	N	REG			0x480X (LTC3888) 0x488x (LTC3888-1)

The following three read-only commands use block format.

MFR_ID

The MFR_ID command returns the manufacturer ID of the LTC3888 or LTC3888-1 (depending on the chip type) using 8-bit ASCII characters.

PMBUS COMMAND DETAILS**IC_DEVICE_ID**

The IC_DEVICE_ID command returns the ADI IC part number using 8-bit ASCII characters.

MFR_SPECIAL_ID

The MFR_SPECIAL_ID command returns a unique binary product code for the device. X is adjustable by the manufacturer.

This read-only command has two data bytes.

OUTLINE DIMENSIONS

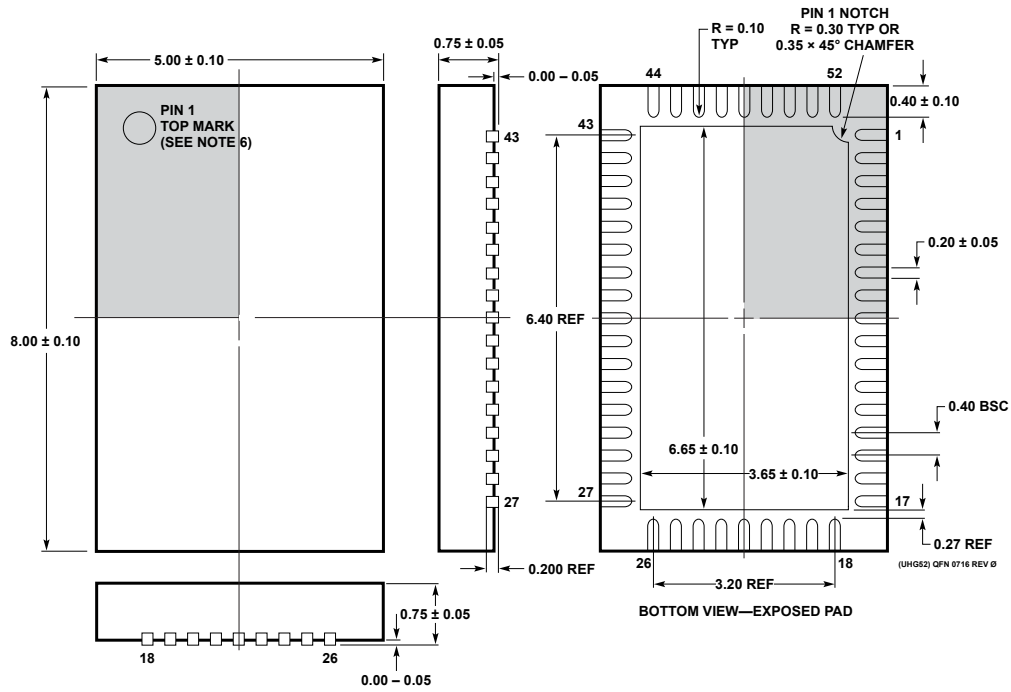
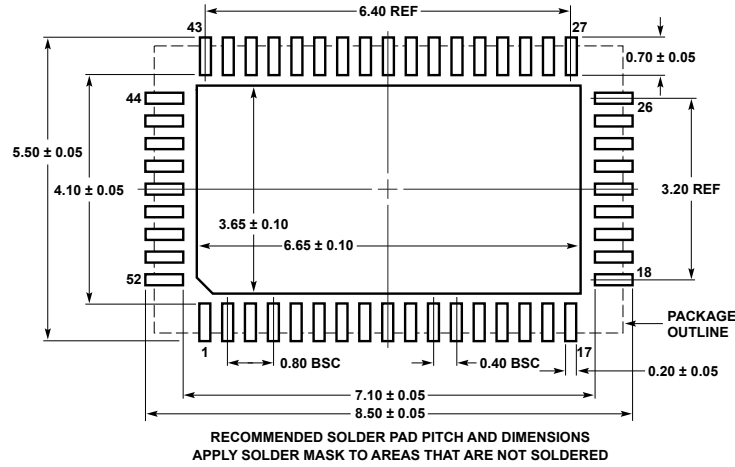

- NOTE:
1. DRAWING CONFORMS TO JEDEC PACKAGE OUTLINE MO-220
 2. DRAWING NOT TO SCALE
 3. ALL DIMENSIONS ARE IN MILLIMETERS
 4. DIMENSIONS OF EXPOSED PAD ON BOTTOM OF PACKAGE DO NOT INCLUDE MOLD FLASH. MOLD FLASH, IF PRESENT, SHALL NOT EXCEED 0.20 mm ON ANY SIDE
 5. EXPOSED PAD SHALL BE SOLDER PLATED
 6. SHADED AREA IS ONLY A REFERENCE FOR PIN 1 LOCATION ON THE TOP AND BOTTOM OF PACKAGE

Figure 89. 52-Lead Plastic QFN
5 mm × 8 mm
(05-08-1550)
Dimensions shown in millimeters

OUTLINE DIMENSIONS

Updated: October 21, 2023

ORDERING GUIDE

Model ^{1, 2}	Temperature Range	Package Description	Packing Quantity	Package Option
LTC3888IUHG#PBF	-40°C to +125°C	52-Lead Plastic QFN (5mm × 8mm)		05-08-1550
LTC3888IUHG#TRPBF	-40°C to +125°C	52-Lead Plastic QFN (5mm × 8mm)	Reel, 2500	05-08-1550
LTC3888IUHG#WPBF	-40°C to +125°C	52-Lead Plastic QFN (5mm × 8mm)		05-08-1550
LTC3888IUHG#WTRPBF	-40°C to +125°C	52-Lead Plastic QFN (5mm × 8mm)	Reel, 2500	05-08-1550
LTC3888IUHG-1#PBF	-40°C to +125°C	52-Lead Plastic QFN (5mm × 8mm)		05-08-1550
LTC3888IUHG-1#TRPBF	-40°C to +125°C	52-Lead Plastic QFN (5mm × 8mm)	Reel, 2500	05-08-1550
LTC3888IUHG-1#WPBF	-40°C to +125°C	52-Lead Plastic QFN (5mm × 8mm)		05-08-1550
LTC3888IUHG-1#WTRPBF	-40°C to +125°C	52-Lead Plastic QFN (5mm × 8mm)	Reel, 2500	05-08-1550
LTC3888IUHG-2#PBF	-40°C to +125°C	52-Lead Plastic QFN (5mm × 8mm)		05-08-1550
LTC3888IUHG-2#TRPBF	-40°C to +125°C	52-Lead Plastic QFN (5mm × 8mm)	Reel, 2500	05-08-1550
LTC3888IUHG-2#WPBF	-40°C to +125°C	52-Lead Plastic QFN (5mm × 8mm)		05-08-1550
LTC3888IUHG-2#WTRPBF	-40°C to +125°C	52-Lead Plastic QFN (5mm × 8mm)	Reel, 2500	05-08-1550

¹ Z = RoHS Compliant Part.

² W = Qualified for Automotive Applications.

EVALUATION BOARDS

Model ¹	Description
DC2652A-A	Evaluation Board
DC2652A-B	Evaluation Board

¹ DC2652A-A and DC2652A-B are RoHS compliant.

AUTOMOTIVE PRODUCTS

The LTC3888W models are available with controlled manufacturing to support the quality and reliability requirements of automotive applications. Note that these automotive models may have specifications that differ from the commercial models; therefore, designers should review the [Specifications](#) section of this data sheet carefully. Only the automotive grade products shown are available for use in automotive applications. Contact your local Analog Devices account representative for specific product ordering information and to obtain the specific Automotive Reliability reports for these models.

Looking for pricing, stock, or lifecycle information?

Click below to explore more details on WIN SOURCE:

- ⊖ [View LTC3888IUHG-1#PBF on WIN SOURCE](#)
- ⊖ [Analog Devices Inc. Information](#)

Optimize Your Supply Chain with WIN SOURCE Solutions

- ✓ Global Sourcing Solution
- ✓ Obsolete Management
- ✓ Cost Control Management
- ✓ Shortage Management
- ✓ Alternative Solution
- ✓ Excess Inventory Management