



**THE DATASHEET OF  
LTC3311JV#PBF**



**5V, 12.5A Synchronous Step-Down Silent Switcher in 3mm × 3mm LQFN**

**FEATURES**

- Pin Compatible with LTC3310/LTC3310S and LTC3311S
- Silent Switcher® Architecture
  - Ultralow EMI Emissions
- High Efficiency—4.5mΩ NMOS and 16mΩ PMOS
- Wide Bandwidth, Fast Transient Response
- Safely Tolerates Inductor Saturation in Overload
- V<sub>IN</sub> Range: 2.25V to 5.5V
- V<sub>OUT</sub> Range: 0.5V to V<sub>IN</sub>
- V<sub>OUT</sub> Accuracy: ±1% with Remote Sense
- Peak Current Mode Control
- Minimum On-Time: 35ns
- Programmable Frequency to 5MHz
- Precision 400mV Enable Threshold, 1μA in Shutdown
- Output Soft-Start with Voltage Tracking
- Power Good Output
- Die Temperature Monitor
- Configurable for Paralleling Power Stages in Forced Continuous Mode
- Thermally-Enhanced 3mm × 3mm LQFN Package
- AEC-Q100 Qualified for Automotive Applications

**APPLICATIONS**

- Automotive/Industrial/Communications
- Servers, Telecom Power Supplies
- Distributed DC Power Systems (POL)
- FPGA, ASIC, μP Core Supplies

**DESCRIPTION**

The LTC®3311/LTC3311-X is a very small, low noise, monolithic step-down DC/DC converter capable of providing up to 12.5A of output current from a 2.25V to 5.5V input supply. The device employs Silent Switcher 1 architecture to achieve both low EMI and high efficiency at switching frequencies as high as 5MHz. For systems with higher power requirements, multi-phasing parallel converters is readily implemented.

The LTC3311/LTC3311-X uses a constant frequency, peak current mode control architecture for fast transient response. A 500mV reference allows for low voltage outputs. 100% duty cycle operation delivers low drop out.

Other features include a power good signal when the output is in regulation, precision enable threshold, output overvoltage protection, thermal shutdown, a temperature monitor, clock synchronization, mode selection and output short circuit protection. The device is available in a compact 18-lead 3mm × 3mm LQFN package.

PART NUMBER	V <sub>OUT</sub>
LTC3311	Adjustable
LTC3311-0.75	0.75V
LTC3311-0.85	0.85V
LTC3311-0.875	0.875V
LTC3311-1	1V

All registered trademarks and trademarks are the property of their respective owners.

**TYPICAL APPLICATION**

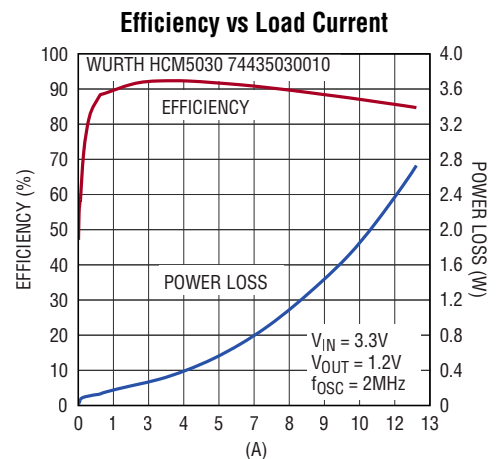
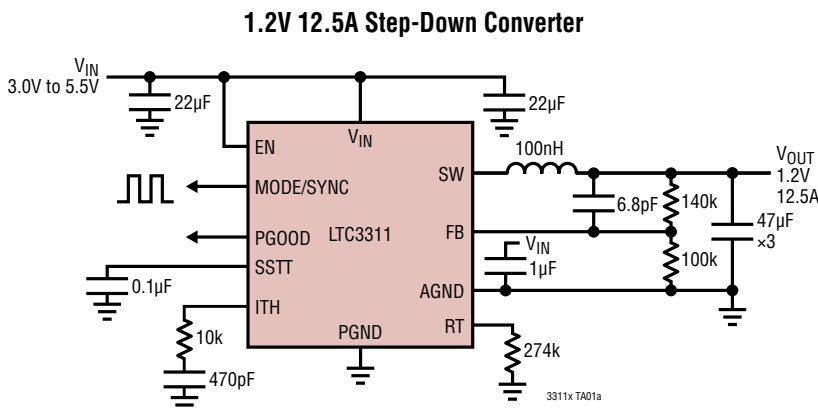

# LTC3311/LTC3311-X

## ABSOLUTE MAXIMUM RATINGS

(Note 1)

$V_{IN}$ .....	-0.3V to 6V
EN, SSTT .....	-0.3V to Lesser of ( $V_{IN} + 0.3V$ ) or 6V
MODE/SYNC .....	-0.3V to Lesser of ( $V_{IN} + 0.3V$ ) or 6V
RT .....	-0.3V to Lesser of ( $V_{IN} + 0.3V$ ) or 6V
FB/ $V_{OUT}$ .....	-0.3V to Lesser of ( $V_{IN} + 0.3V$ ) or 6V
PGOOD .....	-0.3V to 6V
$I_{PGOOD}$ .....	5mA
Operating Junction Temperature Range (Notes 2, 3)	
LTC3311J/LTC3311J-X .....	-40°C to +150°C
LTC3311H .....	-40°C to +150°C
Storage Temperature .....	-65°C to +150°C
Maximum Reflow (Package Body) Temperature ...	260°C

## PIN CONFIGURATION

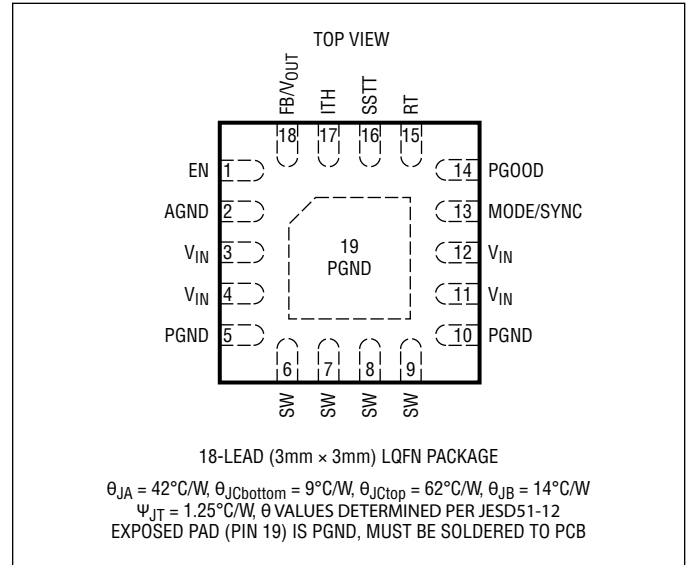

## ORDER INFORMATION

LEAD FREE – TRAY/REEL	AUTOMOTIVE PRODUCTS**	PART MARKING	PACKAGE DESCRIPTION	TEMPERATURE RANGE
LTC3311JV#PBF	LTC3311JV#WPBF	LHMN	18-Lead (3mm × 3mm) LQFN (Laminate Package with QFN Footprint)	-40°C to 150°C
LTC3311HV#PBF	LTC3311HV#WPBF			
LTC3311JV#TRPBF	LTC3311JV#WTRPBF			
LTC3311HV#TRPBF	LTC3311HV#WTRPBF			
LTC3311JV#TRMPBF	LTC3311JV#WTRMPBF			
LTC3311HV#TRMPBF	LTC3311HV#WTRMPBF			
LTC3311JV-0.75#PBF	LTC3311JV-0.75#WPBF	LHPV	18-Lead (3mm × 3mm) LQFN (Laminate Package with QFN Footprint)	-40°C to 150°C
LTC3311JV-0.75#TRPBF	LTC3311JV-0.75#WTRPBF	LHNF	18-Lead (3mm × 3mm) LQFN (Laminate Package with QFN Footprint)	-40°C to 150°C
LTC3311JV-0.75#TRMPBF	LTC3311JV-0.75#WTRMPBF			
LTC3311JV-0.85#PBF	LTC3311JV-0.85#WPBF			
LTC3311JV-0.85#TRPBF	LTC3311JV-0.85#WTRPBF	LHPS	18-Lead (3mm × 3mm) LQFN (Laminate Package with QFN Footprint)	-40°C to 150°C
LTC3311JV-0.85#TRMPBF	LTC3311JV-0.85#WTRMPBF			
LTC3311JV-0.875#PBF	LTC3311JV-0.875#WPBF			
LTC3311JV-0.875#TRPBF	LTC3311JV-0.875#WTRPBF	LHPQ	18-Lead (3mm × 3mm) LQFN (Laminate Package with QFN Footprint)	-40°C to 150°C
LTC3311JV-0.875#TRMPBF	LTC3311JV-0.875#WTRMPBF			
LTC3311JV-1#PBF	LTC3311JV-1#WPBF			
LTC3311JV-1#TRPBF	LTC3311JV-1#WTRPBF			
LTC3311JV-1#TRMPBF	LTC3311JV-1#WTRMPBF			

Contact the factory for parts specified with wider operating temperature ranges. \*The temperature grade is identified by a label on the shipping container.

**Tape and reel specifications.** Some packages are available in 500 unit reels through designated sales channels with #TRMPBF suffix.

\*\*Versions of this part are available with controlled manufacturing to support the quality and reliability requirements of automotive applications. These models are designated with a #W suffix. Only the automotive grade products shown are available for use in automotive applications. Contact your local Analog Devices account representative for specific product ordering information and to obtain the specific Automotive Reliability reports for these models.

Rev. A

## ELECTRICAL CHARACTERISTICS

The ● denotes the specifications which apply over the specified operating temperature range, otherwise specifications are at  $T_A = 25^\circ\text{C}$ . (Notes 2, 3)  $V_{IN} = 3.3\text{V}$ ,  $V_{EN} = V_{IN}$ ,  $\text{MODE}/\text{SYNC} = 0\text{V}$ , unless otherwise noted.

PARAMETER	CONDITIONS		MIN	TYP	MAX	UNITS
<b>Input Supply</b>						
Operating Supply Voltage ( $V_{IN}$ )		●	2.25		5.5	V
$V_{IN}$ Undervoltage Lockout	$V_{IN}$ Rising	●	2.0	2.1	2.2	V
$V_{IN}$ Undervoltage Lockout Hysteresis				150		mV
$V_{IN}$ Quiescent Current	(Note 4)			1.3	2.0	mA
$V_{IN}$ Quiescent Current in Shutdown	$V_{EN} = 0.1\text{V}$			1	2	$\mu\text{A}$
EN Threshold	$V_{EN}$ Rising	●	0.375	0.4	0.425	V
EN Hysteresis				60		mV
EN Pin Leakage Current	$V_{EN} = 0.4\text{V}$				$\pm 20$	nA
<b>Voltage Regulation</b>						
Regulated Feedback Voltage ( $V_{FB}$ )	LTC3311	●	495	500	505	mV
LTC3311-0.75 Regulated Output Voltage (Note 5)	LTC3311-0.75, $I_{OUT} = 8\text{A}$	●	742.5	750	757.5	mV
	LTC3311-0.75, $I_{OUT} = 12.5\text{A}$	●	734.8	743	750.3	mV
	LTC3311-0.75, $I_{OUT} = 0\text{A}$	●	755.2	764	770.4	mV
LTC3311-0.75 $V_{OUT}$ Active Voltage Positioning	LTC3311-0.75			1.6		mV/A
LTC3311-0.85 Regulated Output Voltage (Note 5)	LTC3311-0.85, $I_{OUT} = 6\text{A}$	●	841.5	850	858.5	mV
	LTC3311-0.85, $I_{OUT} = 12.5\text{A}$	●	827.4	837	845.4	mV
	LTC3311-0.85, $I_{OUT} = 0\text{A}$	●	853.4	862	870.6	mV
LTC3311-0.85 $V_{OUT}$ Active Voltage Positioning	LTC3311-0.85			2.0		mV/A
LTC3311-0.875 Regulated Output Voltage (Note 5)	LTC3311-0.875, $I_{OUT} = 6\text{A}$	●	866	875	884	mV
	LTC3311-0.875, $I_{OUT} = 12.5\text{A}$	●	850	862	870.6	mV
	LTC3311-0.875, $I_{OUT} = 0\text{A}$	●	877	888	897	mV
LTC3311-0.875 $V_{OUT}$ Active Voltage Positioning	LTC3311-0.875			2.0		mV/A
LTC3311-1 Regulated Output Voltage (Note 5)	LTC3311-1, $I_{OUT} = 8\text{A}$	●	990	1000	1010	mV
	LTC3311-1, $I_{OUT} = 12.5\text{A}$	●	980	991	1000.9	mV
	LTC3311-1, $I_{OUT} = 0\text{A}$	●	1005.8	1016	1026.2	mV
LTC3311-1 $V_{OUT}$ Active Voltage Positioning	LTC3311-1			2.0		mV/A
Feedback/ $V_{OUT}$ Voltage Line Regulation	$2.5\text{V} \leq V_{IN} \leq 5.0\text{V}$			0.002	0.025	%/V
Feedback Pin Input Current	$V_{FB} = 0.5\text{V}$ (LTC3311 Only)				$\pm 20$	nA
Error Amp Transconductance				1		mS
Error Amp Sink/Source Current				$\pm 45$		$\mu\text{A}$
Top Switch Current Limit	$V_{OUT}/V_{IN} \leq 0.2$ , Current Out of SW	●	15	18	21	A
Bottom Switch Current Limit ( $I_{VALLEY(MAX)}$ )	Current Out of SW	●	12	14	16	A
Top Switch ON-Resistance				16		m $\Omega$
Bottom Switch ON-Resistance				4.5		m $\Omega$
SW Leakage Current	$V_{EN} = 0.1\text{V}$				$\pm 100$	nA
$V_{TH}$ to $I_{Peak}$ Current Gain				26		A/V
Minimum On-Time		●		35	60	ns
Maximum Duty cycle		●	100			%

# LTC3311/LTC3311-X

## ELECTRICAL CHARACTERISTICS

The ● denotes the specifications which apply over the specified operating temperature range, otherwise specifications are at  $T_A = 25^\circ\text{C}$ . (Notes 2, 3)  $V_{IN} = 3.3\text{V}$ ,  $V_{EN} = V_{IN}$ ,  $\text{MODE}/\text{SYNC} = 0\text{V}$ , unless otherwise noted.

PARAMETER	CONDITIONS		MIN	TYP	MAX	UNITS
<b>Power Good/Soft-Start/Temp Monitor</b>						
PGOOD Rising Threshold	As a Percentage of the Regulated $V_{OUT}$	●	97	98	99	%
PGOOD Hysteresis		●	0.5	1	1.5	%
Overshoot Rising Threshold	As a Percentage of the Regulated $V_{OUT}$	●	105	110	115	%
Overshoot Hysteresis		●	1	2.5	3.5	%
PGOOD Leakage Current	$V_{PGOOD} = 5.5\text{V}$				20	nA
PGOOD Pull Down Resistance	$V_{PGOOD} = 0.1\text{V}$			12	20	$\Omega$
PGOOD Delay				125		$\mu\text{s}$
PGOOD Input Threshold	Multi-Phase Mode, Rising	●	390	440	490	mV
PGOOD Input Hysteresis				130		mV
Soft-Start Charge Current	$V_{SSTT} = 0.5\text{V}$	●	7	10	13	$\mu\text{A}$
Temp Monitor Slope				4		$\text{mV}/^\circ\text{C}$
<b>Oscillator</b>						
Switching Frequency Range	$R_T$ Programmable	●	0.5		5	MHz
Switching Frequency	$R_T = 274\text{k}$	●	1.8	2	2.2	MHz
Synchronization Frequency Range	$R_T = V_{IN}$	●	0.5		2.25	MHz
Default Frequency	$R_T = V_{IN}$	●	1.8	2	2.2	MHz
SYNC Level High on MODE/SYNC		●	1.2			V
SYNC Level Low on MODE/SYNC		●			0.4	V
Minimum MODE/SYNC Pulse Width			40			ns
MODE/SYNC Input Resistance				200		$\text{k}\Omega$
MODE/SYNC No Clock Detect Time				20		$\mu\text{s}$
MODE/SYNC Clock Out Rise/Fall Time	$C_{\text{MODE}/\text{SYNC}} = 50\text{pF}$			10		ns
MODE/SYNC Clock Low Output Voltage	$I_{\text{MODE}/\text{SYNC}} = 100\mu\text{A}$			0.2		V
MODE/SYNC Clock High Output Voltage	$I_{\text{MODE}/\text{SYNC}} = 100\mu\text{A}$			$V_{IN} - 0.2$		V
MODE/SYNC Clock Out Duty Cycle				50		%

**Note 1:** Stresses beyond those listed under Absolute Maximum Ratings may cause permanent damage to the device. Exposure to any Absolute Maximum Rating condition for extended periods may affect device reliability and lifetime.

**Note 2:** The LTC3311J/ LTC3311J-X/LTC3311H are guaranteed to meet performance specifications from  $-40^\circ\text{C}$  to  $150^\circ\text{C}$  junction temperature.

**Note 3:** The LTC3311/LTC3311-X includes overtemperature protection which protects the device during momentary overload conditions. Junction temperatures will exceed  $150^\circ\text{C}$  when overtemperature protection is active. Continuous operation above the specified maximum operating junction temperature may impair device reliability.

**Note 4:** Supply current specification does not include switching currents. Actual supply currents will be higher.

**Note 5:** Inductor ripple current equal to 30% of full load (3.75A<sub>p-p</sub>)

## TYPICAL PERFORMANCE CHARACTERISTICS $V_{IN} = 3.3V$ , $T_A = 25^\circ C$ , unless otherwise noted.

**$V_{OUT}$  Line Regulation**  
 $V_{OUT} = 1.2V$

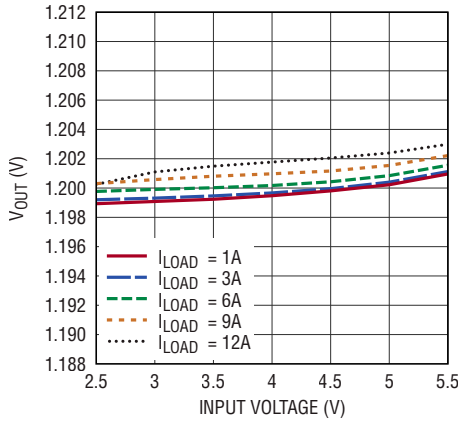

**$V_{OUT}$  Load Regulation**  
 $V_{OUT} = 1.2V$

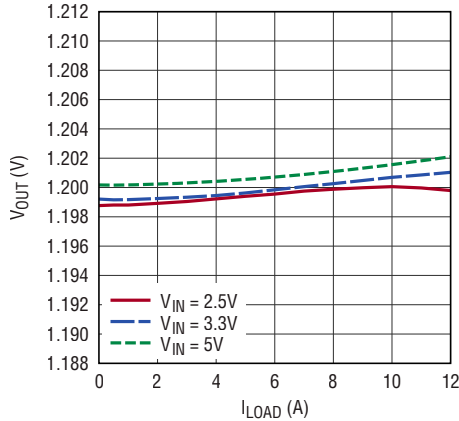

**$V_{OUT}$  Load Regulation**  
LTC3311-0.75

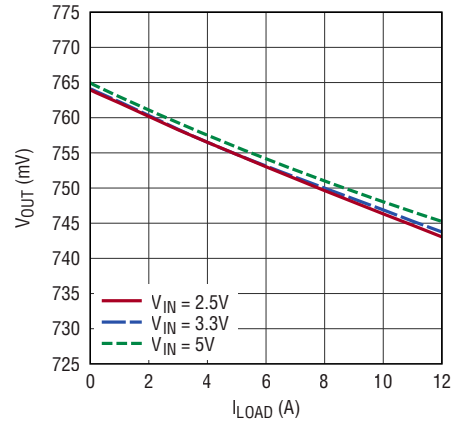

**$V_{OUT}$  Load Regulation**  
LTC3311-0.85

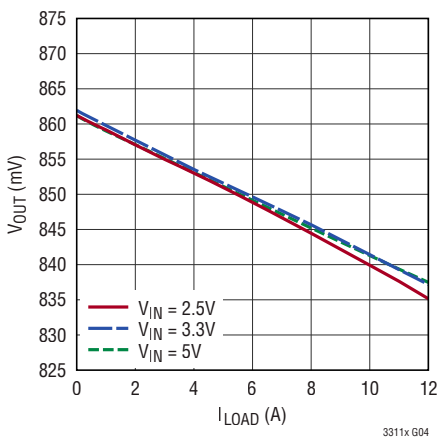

**$V_{OUT}$  Load Regulation**  
LTC3311-0.875

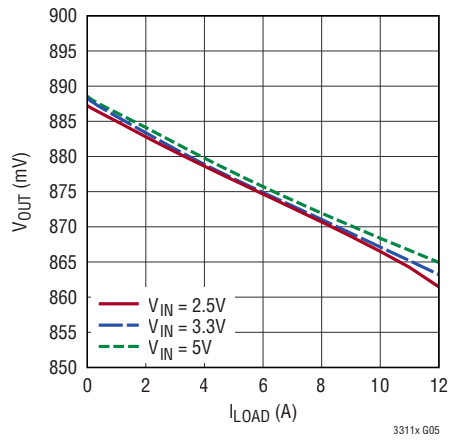

**$V_{OUT}$  Load Regulation**  
LTC3311-1

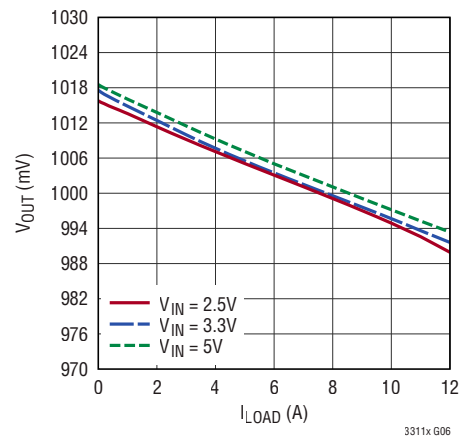

**Efficiency,  $V_{OUT} = 0.5V$**   
Forced Continuous Operation

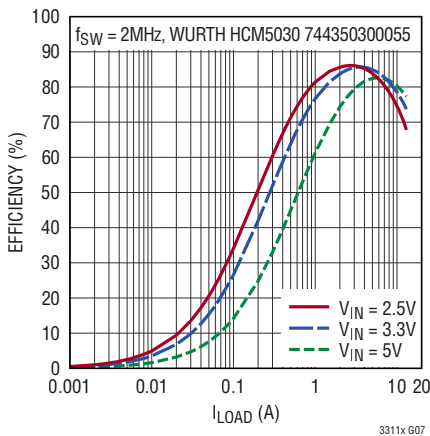

**Efficiency,  $V_{OUT} = 0.5V$**   
Pulse-Skipping Mode Operation

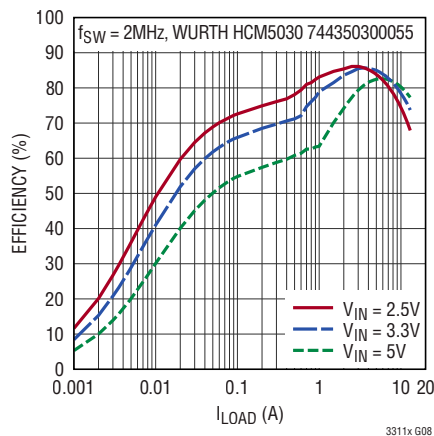

**Efficiency,  $V_{OUT} = 1.2V$**   
Forced Continuous Operation

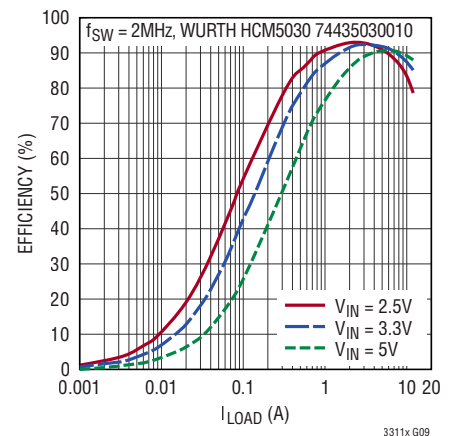

## TYPICAL PERFORMANCE CHARACTERISTICS $V_{IN} = 3.3V$ , $T_A = 25^\circ C$ , unless otherwise noted.

**Efficiency,  $V_{OUT} = 1.2V$   
Pulse-Skipping Mode Operation**

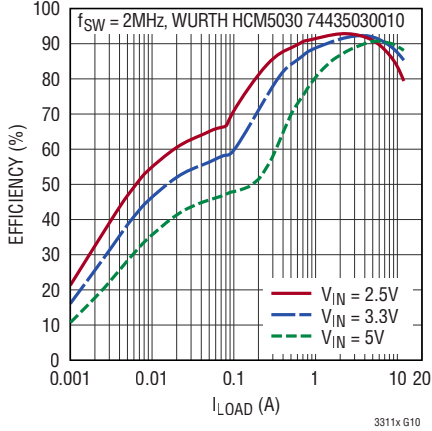

**Efficiency,  $V_{OUT} = 1.8V$   
Forced Continuous Operation**

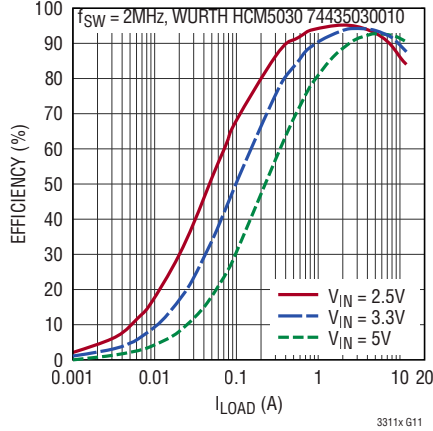

**Efficiency,  $V_{OUT} = 1.8V$   
Pulse-Skipping Mode Operation**

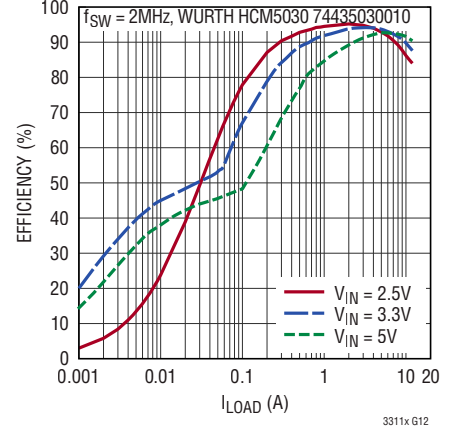

**Feedback Reference Voltage**

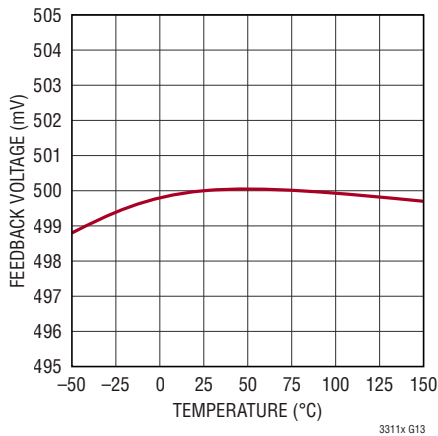

**Switch On Resistance vs  $V_{IN}$**

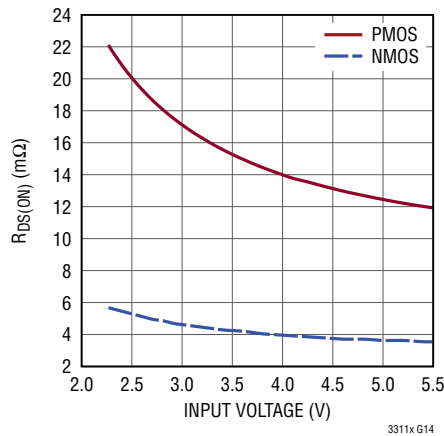

**Switch On Resistance**

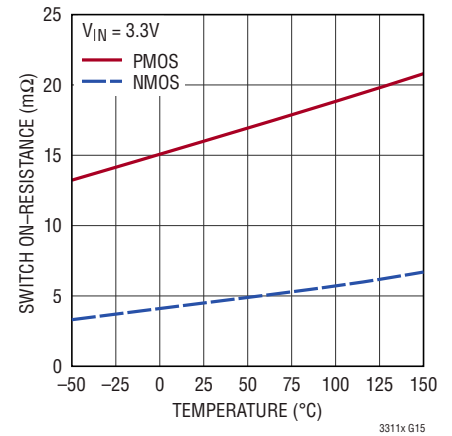

**Switch Leakage**

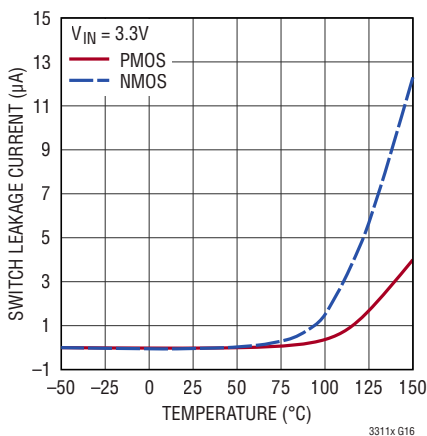

**Default Switching Frequency**

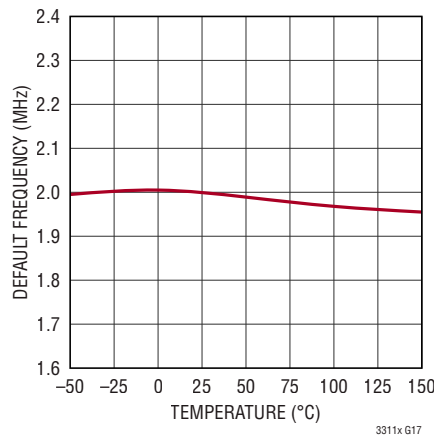

**$V_{IN}$  UVLO Threshold**

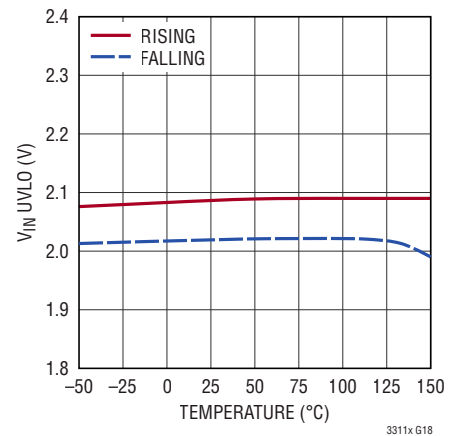

## TYPICAL PERFORMANCE CHARACTERISTICS $V_{IN} = 3.3V$ , $T_A = 25^\circ C$ , unless otherwise noted.

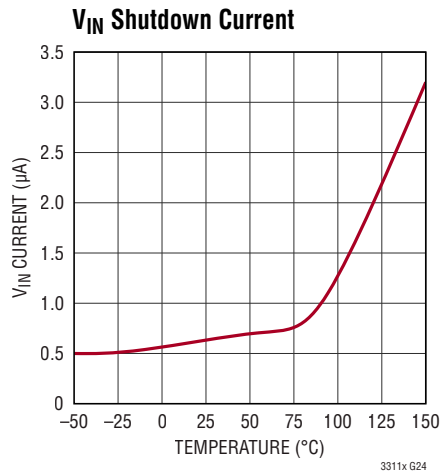
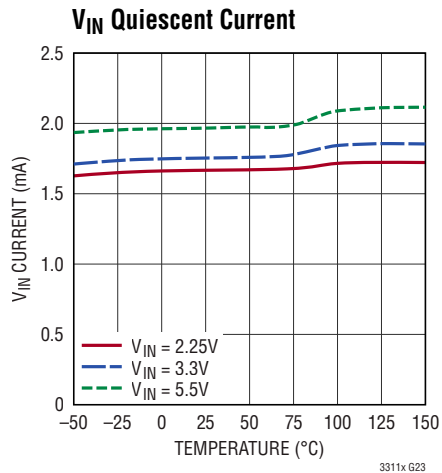
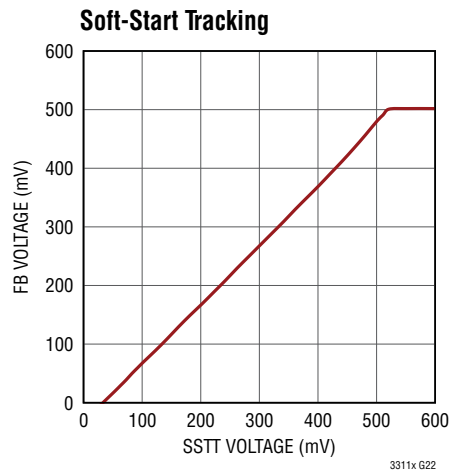
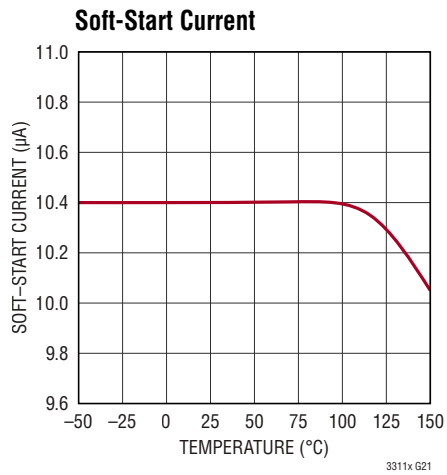
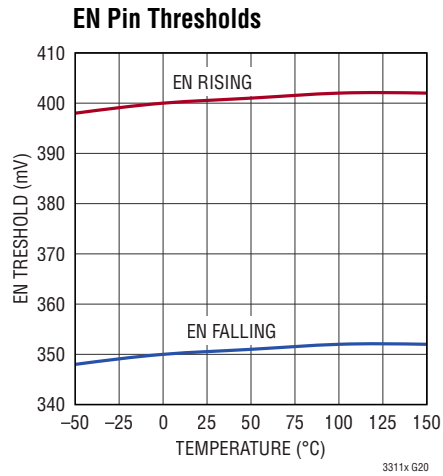
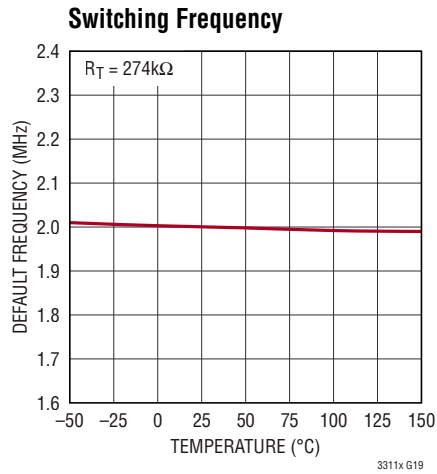

## TYPICAL PERFORMANCE CHARACTERISTICS $V_{IN} = 3.3V$ , $T_A = 25^\circ C$ , unless otherwise noted.

### Switch Current Limit

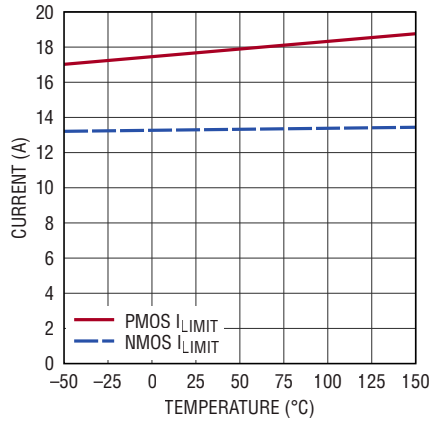

### UV PGOOD Threshold

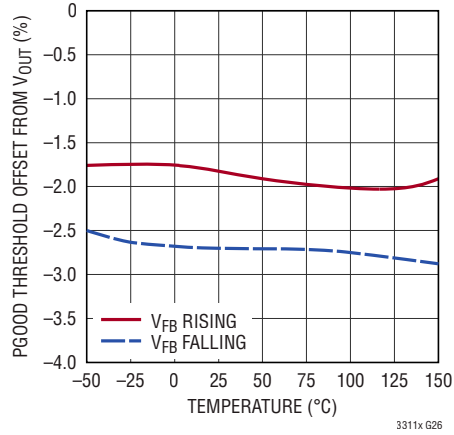

### OV PGOOD Threshold

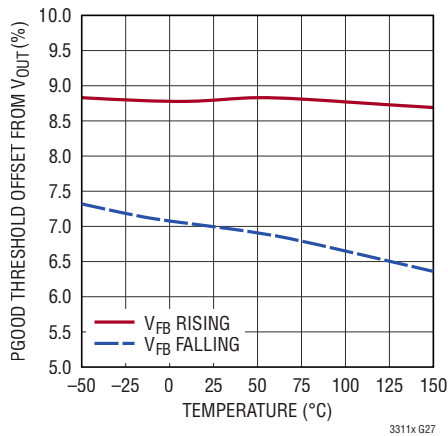

### Minimum On-Time

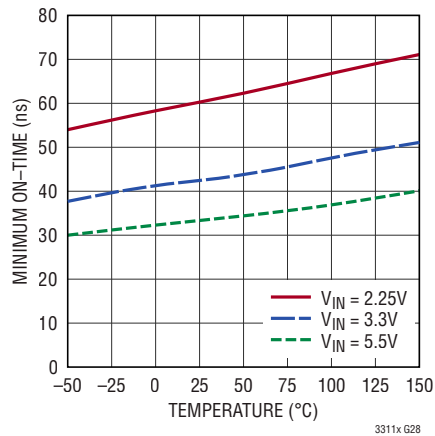

**TYPICAL PERFORMANCE CHARACTERISTICS**  $T_A = 25^\circ\text{C}$ , unless otherwise noted.

**Conducted EMI Performance (CISPR25 Conducted Emission Test with Class 5 Peak Limits)**

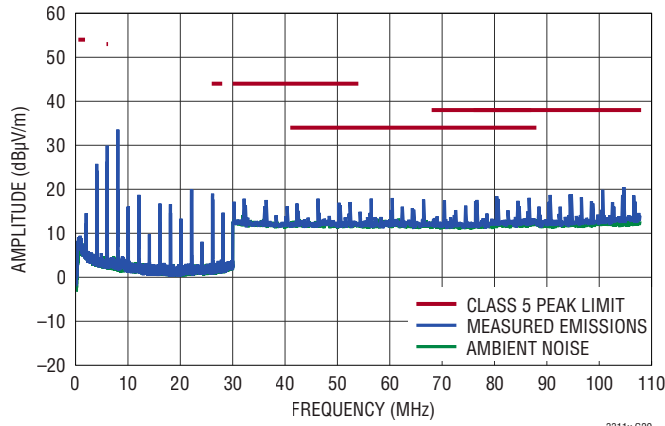

DC3056A DEMO BOARD  
(WITH EMI FILTER INSTALLED)  
3.3V INPUT TO 1.2V OUTPUT AT 10A,  $f_{\text{SW}} = 2\text{MHz}$

3311x G29

**Radiated EMI Performance (CISPR25 Radiated Emissions Test with Class 5 Peak Limits)**

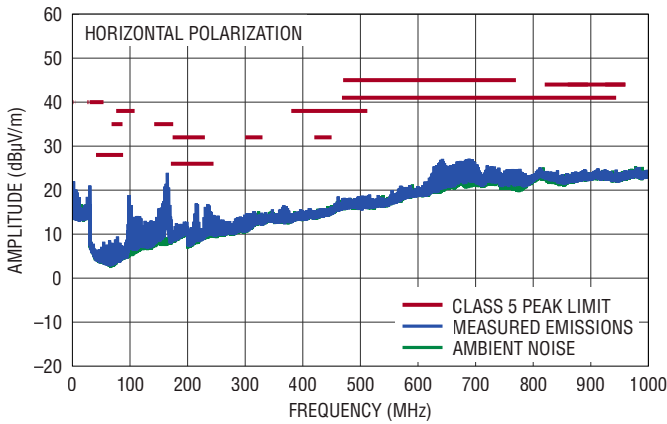

DC3056A DEMO BOARD  
(WITH EMI FILTER INSTALLED)  
3.3V INPUT TO 1.2V OUTPUT AT 10A,  $f_{\text{SW}} = 2\text{MHz}$

3311x G30

**Radiated EMI Performance (CISPR25 Radiated Emissions Test with Class 5 Peak Limits)**

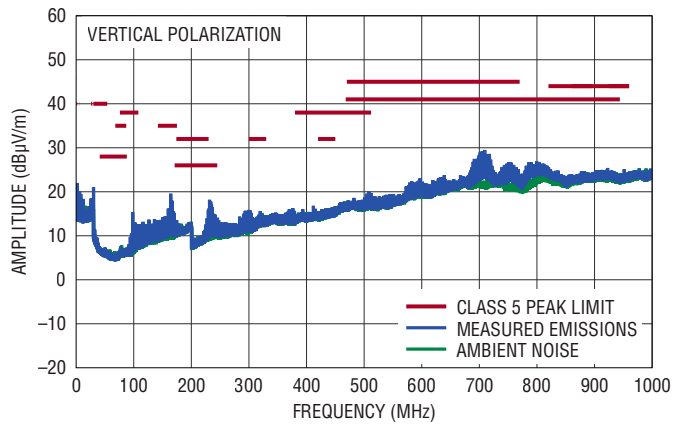

DC3056A DEMO BOARD  
(WITH EMI FILTER INSTALLED)  
3.3V INPUT TO 1.2V OUTPUT AT 10A,  $f_{\text{SW}} = 2\text{MHz}$

3311x G31

## PIN FUNCTIONS

**EN (Pin 1):** The EN pin has a precision enable threshold with hysteresis. An external resistor divider, from  $V_{IN}$  or from another supply, programs the threshold below which the LTC3311/LTC3311-X will shut down. If the precision threshold is not used, directly connect the pin to  $V_{IN}$ . When the EN pin is low, the LTC3311/LTC3311-X enters a low current shutdown mode where all internal circuitry is disabled.

**AGND (Pin 2):** The AGND pin is the output voltage remote ground sense. Connect the AGND pin directly to the negative terminal of the output capacitor at the load and to the feedback divider resistor.

**$V_{IN}$  (Pins 3, 4, 11, 12):** The  $V_{IN}$  pins supply current to the internal circuitry and topside power switch. All of the  $V_{IN}$  pins must be connected together with short, wide traces and bypassed to PGND with low ESR capacitors located as close as possible to the pins.

**PGND (Pins 5, 10, 19):** The PGND pins are the return path of the internal bottom side power switch. Connect the PGND pins together and to the exposed pad. Connect the negative terminal of the input capacitors as close to the PGND pins as possible. The PGND node is the main thermal highway and should be connected to a large PCB ground plane with many large vias.

**SW (Pins 6–9):** The SW pins are the switching outputs of the internal power switches. Connect these pins together to the inductor with short, wide traces.

**MODE/SYNC (Pin 13):** The MODE/SYNC pin facilitates multiphase operation and synchronization to an external clock. Depending on the mode of operation, the MODE/SYNC pin either accepts an input clock pulse or outputs a clock pulse at its operating frequency (see Multiphase Operation in Applications Information). The MODE/SYNC pin also programs the mode of operation: pulse-skipping or forced continuous.

**PGOOD (Pin 14):** The PGOOD pin is a power good pin and is the open drain output of an internal comparator. The PGOOD output is pulled low when  $V_{IN}$  is above 2.25V and the part is in shutdown. When connecting multiple phases in parallel, connect the PGOOD pins together.

**RT (Pin 15):** The RT pin sets the oscillator frequency with an external resistor to AGND or sets the phasing for multiphase operation (see Multiphase Operation in Applications Information).

**SSTT (Pin 16):** Soft-Start, Track, Temperature Monitor. An internal 10 $\mu$ A current into an external capacitor on the soft-start pin programs the output voltage ramp rate during start-up. During the soft-start cycle, the FB pin voltage will track the SSTT pin voltage. When the soft-start cycle is complete, the tracking function is disabled, the internal reference resumes control of the error amplifier and the SSTT pin servos to a voltage representative of junction temperature. For a clean recovery from an output short circuit condition, the SSTT pin is pulled down to approximately 140mV above the  $V_{FB}$  voltage and a new soft-start cycle is initiated. During shutdown and fault conditions, the SSTT pin is pulled to ground.

**ITH (Pin 17):** The ITH pin is the compensation node for the output voltage regulation control loop. Compensation components connected to this pin are referenced to AGND.

**FB (Pin 18, LTC3311):** The output voltage feedback pin is externally connected to the output voltage via a resistive divider and is internally connected to the inverting input of the error amplifier. The LTC3311 regulates the FB pin to 500mV. A phase lead capacitor connected between  $V_{FB}$  and  $V_{OUT}$  is used to optimize the transient response.

**$V_{OUT}$  (Pin 18, LTC3311-X):** The output voltage pin is externally connected to the output voltage and is internally connected to a resistive divider.

**BLOCK DIAGRAM**

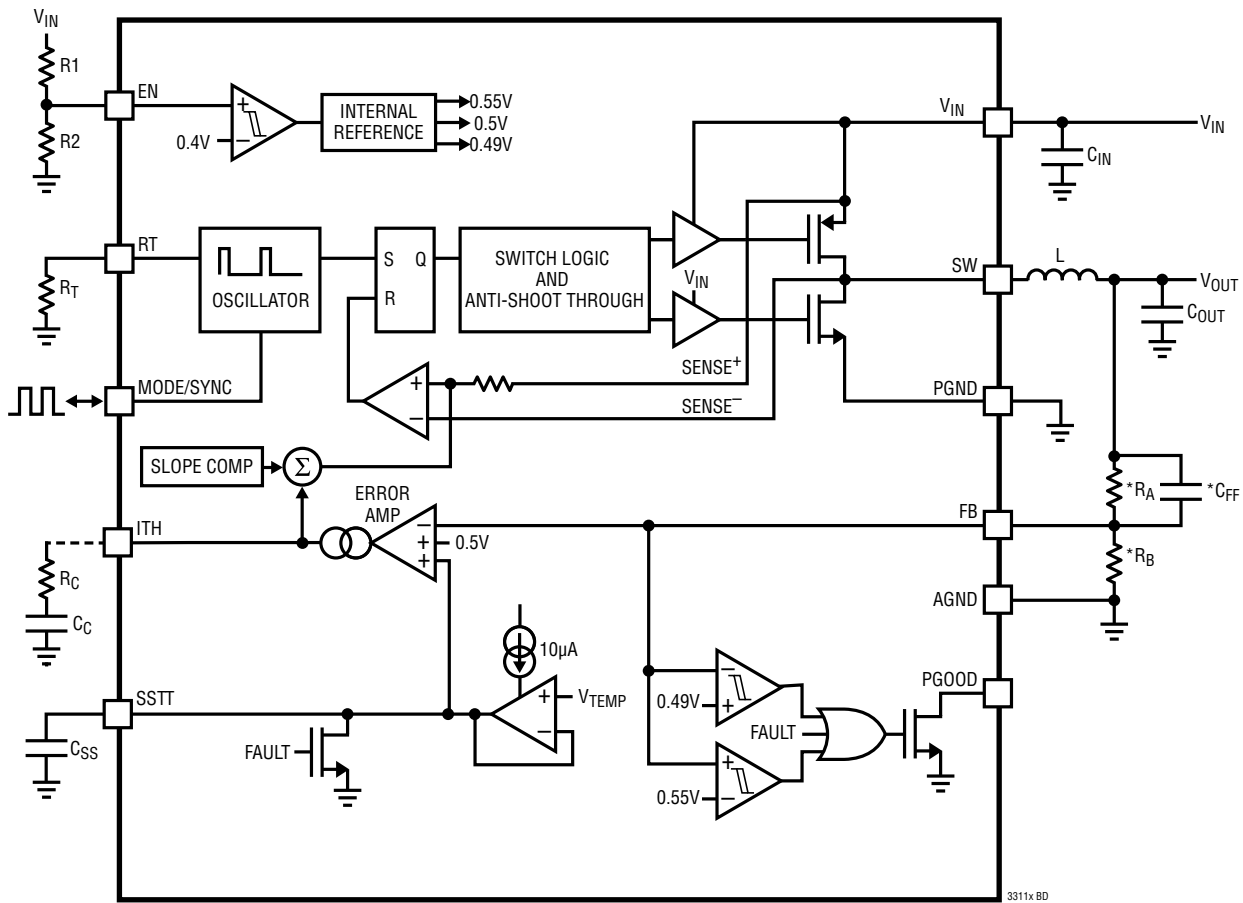

\*ON THE LTC3311-X, THE RA AND RB RESISTORS ARE INTERNAL, ALONG WITH CFF

## OPERATION

### Voltage Regulation

The LTC3311/LTC3311-X is a monolithic, constant frequency, current mode step-down DC/DC converter. An oscillator turns on the internal top power switch at the beginning of each clock cycle. Current in the inductor increases until the top switch current comparator trips and turns off the top power switch. The peak inductor current at which the top switch turns off is controlled by the voltage on the ITH node. The error amplifier servos the ITH node by comparing the voltage on the FB node with an internal 500mV reference. When the load current increases, it causes a reduction in the feedback voltage relative to the reference leading the error amplifier to raise the ITH voltage until the average inductor current matches the new load current. When the top power switch turns off, the synchronous power switch turns on until the next clock cycle begins or, in pulse-skipping mode, inductor current falls to zero. If overload conditions result in excessive current flowing through the bottom switch, the next clock cycle will be delayed until switch current returns to a safe level.

On the LTC3311, the output voltage is resistively divided externally to create a feedback voltage for the regulator. In high current operation, a ground offset may be present between the LTC3311 local ground and ground at the load. To overcome this offset, AGND should have a Kelvin connection to the load ground, and the lowest potential node of the resistor divider should be connected to AGND. The internal error amplifier senses the difference between this feedback voltage and a 0.5V AGND referenced voltage. This scheme overcomes any ground offsets between local ground and remote output ground, resulting in a more accurate output voltage. The LTC3311/LTC3311-X allows for remote output ground deviations as much as  $\pm 100\text{mV}$  with respect to local ground.

If the EN pin is low, the LTC3311/LTC3311-X is shut down and in a low quiescent current state. When the EN pin is above its threshold, the switching regulator will be enabled.

### Synchronizing the Oscillator to an External Clock

The LTC3311/LTC3311-X's internal oscillator is synchronized through an internal PLL circuit to an external frequency by applying a square wave clock signal to the MODE/SYNC pin.

During synchronization, the top power switch turn-on is locked to the rising edge of the external frequency source. While synchronizing, the switcher operates in forced continuous mode. The slope compensation is automatically adapted to the external clock frequency.

After detecting an external clock on the first rising edge of the MODE/SYNC pin, the internal PLL gradually adjusts its operating frequency to match the frequency and phase of the signal on the MODE/SYNC pin. When the external clock is removed, the LTC3311/LTC3311-X detects the absence of the external clock within approximately 20 $\mu\text{s}$ . During this time, the PLL will continue to provide clock cycles. Once the external clock removal has been detected, the oscillator gradually adjusts its operating frequency back to the default frequency.

### Mode Selection

The MODE/SYNC pin either synchronizes the switching frequency to an external clock, is a clock output, or sets the PWM mode. The PWM modes of operation are either pulse-skipping or forced continuous. See Table 6 in the Applications Information section. In pulse-skipping mode, switching cycles are skipped at light loads to regulate the output voltage. During forced continuous mode, the top switch turns on every cycle and light load regulation is achieved by allowing negative inductor current.

### Output Power Good

Comparators monitoring the FB node voltage pull the PGOOD pin low if the output voltage varies from the nominal set point or if a fault condition is present. The comparator includes voltage hysteresis. A time delay to report PGOOD is used to filter short duration output voltage transients.

## OPERATION

### Soft-Start/Tracking/Temperature Monitor

The soft-start tracking function facilitates supply sequencing, limits  $V_{IN}$  inrush current, and reduces start-up output overshoot. When soft-starting is completed, the SST pin parks itself at a voltage representative of the LTC3311/LTC3311-X die junction temperature. The SST capacitor is reset during shutdown,  $V_{IN}$  UVLO, and thermal shutdown. See Application section.

### Dropout Operation

As the input supply voltage approaches the output voltage, the duty cycle increases. Further reduction of the supply voltage forces the main switch to remain on for more than one cycle, eventually reaching 100% duty cycle. The output voltage will then be determined by the input voltage minus the DC voltage drop across the internal main P-channel MOSFET and the inductor.

In many designs when the input voltage approaches the output voltage, the amplitude of the output ripple voltage increases from its normally low value. To avoid any increase in output ripple voltage under these conditions, it is recommended to utilize a resistor divider on the EN input and limit the  $V_{IN}$  turn-on and turn-off thresholds to where the output ripple voltage is acceptable for the given application (typically 500mV above  $V_{OUT}$ ).

### Low Supply Operation

The LTC3311/LTC3311-X is designed to operate down to an input supply voltage of 2.25V. An important thermal design consideration is that the  $R_{DS(ON)}$ s of the power switches increase at low  $V_{IN}$ . Calculate the worst case LTC3311 power dissipation and die junction temperature at the lowest input voltages.

### Output Short-Circuit Protection and Recovery

The peak inductor current level, at which the current comparator shuts off the top power switch, is controlled by the voltage on the ITH pin. If the output current increases, the error amplifier raises the ITH pin voltage until the average inductor current matches the load current. The LTC3311/LTC3311-X clamps the maximum ITH pin voltage, thereby limiting the peak inductor current.

When the output is shorted to ground, the inductor current decays very slowly during a single switching cycle because the voltage across the inductor is low. To keep the inductor current in control, a secondary limit is imposed on the valley of the inductor current. If the inductor current measured through the bottom power switch is greater than the  $I_{VALLEY(MAX)}$  the top power switch will be held off. Subsequent switching cycles will be skipped until the inductor current is reduced below  $I_{VALLEY(MAX)}$ .

Recovery from an output short circuit goes through a soft-start cycle. When  $V_{OUT}$  goes below regulation, as defined by the PGOOD threshold, the SST voltage is pulled to a voltage just above the FB voltage. Because the SST pin is pulled low, a soft-start cycle is initiated once the output short is removed.

### Active Voltage Positioning

The LTC3311-X include active voltage positioning (AVP) where the output voltage is dependent on load current. At light loads the output voltage is regulated above the nominal value. At full load the output voltage is regulated below the nominal value. The DC load regulation is adjusted to improve transient performance and reduce output capacitor requirements.

## APPLICATIONS INFORMATION

Refer to the Block Diagram for reference.

### FB Resistor Network

The output voltage on the LTC3311 is programmed with a resistor divider between the output and the FB pin. Choose the resistor values according to Equation 1.

$$R_A = R_B \left( \frac{V_{OUT}}{500mV} - 1 \right) \quad (1)$$

as shown in Figure 1:

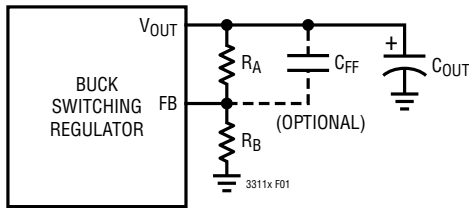

**Figure 1. Feedback Resistor Network**

Reference designators refer to the Block Diagram. 1% resistors are recommended to maintain output voltage accuracy. When optimizing the control loop for high bandwidth and optimal transient response, add a phase-lead capacitor connected from  $V_{OUT}$  to FB.

### Operating Frequency Selection and Trade-Offs

Selection of the operating frequency is a trade-off between efficiency, component size, transient response and input voltage range.

The advantage of high frequency operation is that smaller inductor and capacitor values may be used. Higher switching frequencies allow for higher control loop bandwidth and, therefore, faster transient response. The disadvantages of higher switching frequencies are lower efficiency, because of increased switching losses, and a smaller input voltage range, because of minimum switch on-time limitations.

Although the maximum programmable switching frequency is 5MHz, the minimum on-time of the LTC3311/LTC3311-X imposes a minimum operating duty cycle.

The highest switching frequency ( $f_{SW(MAX)}$ ) for a given application can be calculated using Equation 2.

$$f_{SW(MAX)} = \frac{V_{OUT}}{t_{ON(MIN)} \cdot V_{IN(MAX)}} \quad (2)$$

where  $V_{IN(MAX)}$  is the maximum input voltage,  $V_{OUT}$  is the output voltage and  $t_{ON(MIN)}$  is the minimum top switch on-time. Equation 2 shows that a slower switching frequency is necessary to accommodate a high  $V_{IN}/V_{OUT}$  ratio.

The LTC3311/LTC3311-X is capable of a maximum duty cycle of 100%, therefore, the  $V_{IN}$ -to- $V_{OUT}$  dropout is limited by the  $R_{DS(ON)}$  of the top switch, the inductor DCR, and the load current.

### Setting the Switching Frequency

The LTC3311/LTC3311-X uses a constant frequency PWM architecture. There are three methods to set the switching frequency. The first method is with a resistor ( $R_T$ ) tied from the RT pin to ground. The frequency can be programmed to switch from 500kHz to 5MHz. Table 1 shows the necessary  $R_T$  value for a desired switching frequency.

The  $R_T$  resistor required for a desired switching frequency is calculated using Equation 3.

$$R_T = \frac{580}{f_{SW}} - 16 \quad (3)$$

where  $R_T$  is in  $k\Omega$  and  $f_{SW}$  is the desired switching frequency in MHz.

**Table 1. Switching Frequency vs  $R_T$  Value**

$f_{SW}$ (MHz)	$R_T$ ( $k\Omega$ )
0.5	1210
1	549
2	274
2.2	243
3	178
4	130
5	100

## APPLICATIONS INFORMATION

The second method to set the LTC3311/LTC3311-X switching frequency is by synchronizing the internal PLL circuit to an external frequency applied to the MODE/SYNC pin. The synchronization frequency range is 0.5MHz to 2.25MHz.

The internal PLL starts up at the 2MHz default frequency. After detecting an external clock on the first rising edge of the MODE/SYNC pin, the internal PLL gradually adjusts its operating frequency to match the frequency and phase of the MODE/SYNC signal.

The LTC3311/LTC3311-X detects when the external clock is removed and will gradually adjust its operating frequency to the 2MHz default frequency. The LTC3311/LTC3311-X operates in forced continuous mode when synchronized to an external clock.

The third method of setting the LTC3311/LTC3311-X switching frequency is to use the internal nominal 2MHz default clock. See Table 4 for pin configuration.

### Inductor Selection and Maximum Output Current

Considerations in choosing an inductor are inductance, RMS current rating, saturation current rating, DCR, and core loss.

A good first choice for the inductor value is given by Equation 4 and Equation 5.

$$L \approx \frac{V_{OUT}}{3.75A \cdot f_{SW}} \cdot \left( 1 - \frac{V_{OUT}}{V_{IN(MAX)}} \right) \text{ for } \frac{V_{OUT}}{V_{IN(MAX)}} \leq 0.5 \quad (4)$$

$$L \approx \frac{0.25 \cdot V_{IN(MAX)}}{3.75A \cdot f_{SW}} \text{ for } \frac{V_{OUT}}{V_{IN(MAX)}} > 0.5 \quad (5)$$

where  $f_{SW}$  is the switching frequency in MHz,  $V_{IN}$  is the input voltage, and  $L$  is the inductor value in  $\mu\text{H}$ .

To avoid overheating of the inductor, choose an inductor with an RMS current rating that is greater than the maximum expected output load of the application. Overload and short circuit conditions may need to be taken into consideration.

In addition, the saturation current ( $I_{SAT}$ ) rating of the inductor must be higher than the load current plus 1/2 of the inductor ripple current (Equation 6).

$$I_{SAT} \geq I_{LOAD(MAX)} + \frac{1}{2} \Delta I_L \quad (6)$$

where  $I_{LOAD(MAX)}$  is the maximum output load current for a given application and  $\Delta I_L$  is the inductor ripple current calculated using Equation 7.

$$\Delta I_L = \frac{V_{OUT}}{L \cdot f_{SW}} \cdot \left( 1 - \frac{V_{OUT}}{V_{IN(MAX)}} \right) \quad (7)$$

where  $V_{IN(MAX)}$  is the maximum application input voltage.

To keep the efficiency high, choose an inductor with the lowest series resistance (DCR). The core material should be intended for high frequency applications.

The LTC3311 limits the peak switch current in order to protect the switches and the system from overload faults. The inductor value must then be sufficiently large to supply the desired maximum output current,  $I_{OUT(MAX)}$ , which is a function of the switch current limit,  $I_{LIM}$ , and the ripple current (Equation 8).

$$I_{OUT(MAX)} = I_{LIM} - \frac{\Delta I_L}{2} \quad (8)$$

Therefore, the maximum output current that the LTC3311/LTC3311-X will deliver depends on the switch current limit, the inductor value, and the input and output voltages. The inductor value may have to be increased if the inductor ripple current does not allow sufficient maximum output current ( $I_{OUT(MAX)}$ ) given the switching frequency, and maximum input voltage used in the desired application.

**Table 2. Inductor Manufacturers**

VENDOR	URL
Coilcraft	<a href="http://www.coilcraft.com">www.coilcraft.com</a>
Sumida	<a href="http://www.sumida.com">www.sumida.com</a>
TDK	<a href="http://www.tdk.com">www.tdk.com</a>
Toko	<a href="http://www.toko.com">www.toko.com</a>
Vishay	<a href="http://www.vishay.com">www.vishay.com</a>
Würth Elektronik	<a href="http://www.we-online.com">www.we-online.com</a>
XFMRS	<a href="http://www.xfmrs.com">www.xfmrs.com</a>

### Input Capacitors

Bypass the input of the LTC3311/LTC3311-X with at least two bulk storage ceramic capacitors close to the part,

## APPLICATIONS INFORMATION

one on each side from  $V_{IN}$  to PGND. These capacitors should be 0603 or 0805 in size. See layout section for more detail. X7R or X5R capacitors are recommended for best performance across temperature and input voltage variations. Note that larger input capacitance is required when a lower switching frequency is used. For high frequency applications, adding two small capacitors close to the part is recommended. If the input power source has high impedance, or there is significant inductance due to long wires or cables, additional bulk capacitance may be necessary. This can be provided with a low performance electrolytic capacitor.

A ceramic input capacitor combined with trace or cable inductance forms a high quality (under damped) tank circuit. If the LTC3311/LTC3311-X circuit is plugged into a live supply, the input voltage can ring to twice its nominal value, possibly exceeding the LTC3311/LTC3311-X's voltage rating. This situation is easily avoided (see Analog Devices [Application Note 88](#)).

**Table 3. Ceramic Capacitor Manufacturers**

VENDOR	URL
AVX	<a href="http://www.avxcorp.com">www.avxcorp.com</a>
Murata	<a href="http://www.murata.com">www.murata.com</a>
TDK	<a href="http://www.tdk.com">www.tdk.com</a>
Taiyo Yuden	<a href="http://www.t-yuden.com">www.t-yuden.com</a>
Samsung	<a href="http://www.samsungsem.com">www.samsungsem.com</a>

### Output Capacitor and Output Ripple

The output capacitor has two essential functions. Along with the inductor, it filters the square wave, generated by the LTC3311/LTC3311-X, to produce the DC output. In this role it determines the output ripple, thus, low impedance at the switching frequency is important. The second function is to store energy in order to satisfy transient loads and stabilize the LTC3311/LTC3311-X's control loop. Ceramic capacitors have very low equivalent series resistance (ESR) and provide

the best ripple performance. For good starting values, see the Typical Applications section.

X5R or X7R type capacitors will provide low output ripple and good transient response. Transient performance is improved with a higher value output capacitor and the addition of a feedforward capacitor placed between  $V_{OUT}$  and FB. Increasing the output capacitance will also decrease the output voltage ripple. A lower value of output capacitor saves space and cost but transient performance will suffer and may cause loop instability. See the Typical Applications for suggested capacitor values.

### Multiphase Operation

The LTC3311/LTC3311-X is easily configurable for multiphase operation. See Table 4. The LTC3311-X can only be configured as master phase.

Connecting the RT pin of the master phase to a resistor to AGND programs the frequency and configures the MODE/SYNC pin to become clock output used to drive the MODE/SYNC pin of the slave phase(s).

Connecting the RT pin of the master phase to  $V_{IN}$  configures the MODE/SYNC pin to become an input capable of accepting an external clock. The switching frequency defaults to the nominal 2MHz internal frequency when the external clock is unavailable, such as during start-up.

Connecting the FB pin to  $V_{IN}$  configures a phase as a slave. The MODE/SYNC becomes an input and the voltage control loop is disabled. The slave phase current control loop is still active and the peak current is controlled via the shared ITH node. Careful consideration should be taken when routing the ITH node between phases. Routing the ITH and AGND nodes together is recommended to create a low inductance path. See the Multi-Phase Demo Board PCB layout as an example.

Connecting the PGOOD pins together and adding an external pull-up resistor allows the master phase to

**Table 4. LTC3311 Multiphase Configuration**

MASTER/SLAVE	RT PIN	FB PIN	MODE/SYNC PIN	SWITCHING FREQUENCY ( $f_{sw}$ )
Master	$V_{IN}$	$V_{OUT}$ Divider	Clock Input	External Clock/2MHz Default
Master	Resistor to AGND	$V_{OUT}$ Divider	Clock Output	$R_T$ -Programmed
Slave	$V_{IN}$ Divider	$V_{IN}$	Clock Input	External Clock

## APPLICATIONS INFORMATION

communicate with the slave phases on when start-up has been completed.

The phasing of a slave phase relative to the master phase is programmed with a resistor divider on the RT pin. Use of 1% resistors is recommended. See Table 5 for more information.

**Table 5. LTC3311 Programming Slave Phase Angle**

SYNC PHASE ANGLE	R3 VALUE	R4 VALUE	R3 EXAMPLE	R4 EXAMPLE
0°	0Ω	None	0Ω	None
90°	3 • R	R	301k	100k
120°	7 • R	5 • R	243k	174k
180°	None	0Ω	None	0Ω
240°	5 • R	7 • R	174k	243k
270°	R	3 • R	100k	301k

When configured for master/slave operation, the slave phases operate in forced continuous mode.

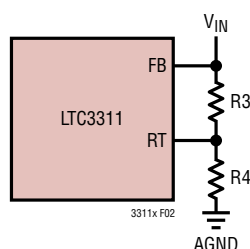

**Figure 2. Phase Programming**

### MODE of Operation

For most configurations, the LTC3311/LTC3311-X operates in forced continuous mode. While in forced continuous mode, regulation at low currents is achieved by allowing negative inductor current. Switching cycles are not skipped.

The LTC3311/LTC3311-X operates in pulse-skipping mode when both the  $R_T$  and MODE/SYNC pins are connected to  $V_{IN}$ . In this mode, the switching frequency is set with the nominal 2MHz internal clock. While in pulse-skipping mode negative current is disallowed and regulation at low currents is achieved by skipping switching cycles.

**Table 6. LTC3311/LTC3311-X Single Phase Configuration**

RT PIN CONNECTION	MODE/SYNC PIN CONNECTION	MODE OF OPERATION	SWITCHING FREQUENCY
$V_{IN}$	Clock Input	Forced Continuous	External Clock
$V_{IN}$	AGND	Forced Continuous	2MHz Default
$V_{IN}$	$V_{IN}$	Pulse-Skipping	2MHz Default
Resistor to AGND	Clock Output	Forced Continuous	$R_T$ -Programmed

### Synchronization

To synchronize the LTC3311/LTC3311-X oscillator to an external frequency, configure the MODE/SYNC pin as an input by connecting the RT pin to  $V_{IN}$ . Drive the MODE/SYNC pin with a square wave in the frequency range of 500kHz to 2.25MHz, and with an amplitude greater than 1.2V and less than 0.4V with a pulse width greater than 40ns.

The LTC3311/LTC3311-X phase-locked loop (PLL) will synchronize the internal oscillator to the clock applied to the MODE/SYNC pin. At start up, before the LTC3311/LTC3311-X recognizes the external clock applied to MODE/SYNC, the LTC3311/LTC3311-X will switch at its default frequency of 2MHz. Once the externally applied clock is recognized, the switching frequency will gradually transition from the default frequency to the applied frequency. If the external clock is removed, the LTC3311/LTC3311-X will slowly transition back to the default frequency.

The LTC3311/LTC3311-X operates in forced continuous mode during synchronization. An internal 200kΩ resistor on the MODE/SYNC pin to AGND allows the MODE/SYNC pin to be left floating.

### Transient Response and Loop Compensation

When determining the compensation components,  $C_{FF}$ ,  $R_C$ , and  $C_C$ , control loop stability and transient response are the two main considerations.

The LTC3311/LTC3311-X has been designed to operate at a high bandwidth for fast transient response capability. Operating at a high loop bandwidth reduces the output capacitance required to meet transient response requirements.

## APPLICATIONS INFORMATION

Applying a load transient and monitoring the response of the system or using a network analyzer to measure the actual loop response are two ways to verify and optimize the control loop stability. LTpowerCAD® is a useful tool to help optimize the compensation components.

When using the load transient response method to stabilize the control loop, apply an output current pulse of 20% to 100% of full load current having a rise time of 1μs. This will produce a transient on the output voltage and ITH pin waveforms.

Switching regulators take multiple cycles to respond to a step in load current. When a load step occurs,  $V_{OUT}$  is immediately perturbed, generating a feedback error signal used by the regulator to return  $V_{OUT}$  to its steady-state value.

During this recovery time, monitor  $V_{OUT}$  for overshoot or ringing that would indicate a stability problem. The initial output voltage step may not be within the bandwidth of the feedback loop, so the standard second order overshoot/DC ratio cannot be used to determine phase margin. The gain of the loop increases with  $R_C$  and the bandwidth of the loop increases with decreasing  $C_C$ . If  $R_C$  is increased by the same factor that  $C_C$  is decreased, the zero frequency will be kept the same, thereby keeping the phase the same in the most critical frequency range of the feedback loop. In addition, adding a feed forward capacitor,  $C_{FF}$ , improves the high frequency response. Capacitor  $C_{FF}$  provides phase lead by creating a high frequency zero with  $R_A$  to improve the phase margin. The compensation components of the typical application circuits are a good starting point for component values.

The output voltage settling behavior is related to the stability of the closed-loop system. For a detailed explanation of optimizing the compensation components, including a review of control loop theory, refer to Analog Devices [Application Note 76](#).

### Output Overvoltage Protection

During an output overvoltage event, when the FB node voltage is greater than 110% of nominal, the LTC3311/LTC3311-X top power switch will be turned off. If the output remains out of regulation for more than 125μs, the PGOOD pin will be pulled low.

An output overvoltage event should not happen under normal operating conditions.

### Output Voltage Sensing

The LTC3311/LTC3311-X AGND pin is the ground reference for the internal analog circuitry, including the band-gap voltage reference. To achieve good load regulation, connect the AGND pin to the negative terminal of the output capacitor ( $C_{OUT}$ ) at the load. A drop in the high current power ground return path will be compensated. All of the signal components, such as the FB resistor divider (LTC3311 only) and soft-start capacitor, should be referenced to the AGND node. The AGND node carries very little current and, therefore, can be a minimal size trace. See the example PCB Layout for more information.

### Enable Threshold Programming

The LTC3311/LTC3311-X has a precision threshold enable pin to enable or disable switching. When forced low, the LTC3311/LTC3311-X enters a low current shutdown mode.

The rising threshold of the EN comparator is 400mV, with 60mV of hysteresis. Connect the EN pin to  $V_{IN}$  if the shutdown feature is not used. Adding a resistor divider from  $V_{IN}$  to EN programs the LTC3311/LTC3311-X to regulate the output only when  $V_{IN}$  is above a desired voltage (see the Block Diagram). Typically, this threshold,  $V_{IN(EN)}$ , is used in situations where the input supply is current limited or has a relatively high source resistance. A switching regulator draws constant power from the source, so source current increases as source voltage drops. This looks like a negative resistance load to the source and can cause the source to current limit or latch low under low source voltage conditions. The  $V_{IN(EN)}$  threshold prevents the regulator from operating at source voltages where problems may occur. This threshold can be adjusted by setting the values  $R_1$  and  $R_2$  such that they satisfy Equation 9.

$$V_{IN(EN)} = \left( \frac{R_1}{R_2} + 1 \right) \cdot 400\text{mV} \quad (9)$$

where the LTC3311/LTC3311-X will remain off until  $V_{IN}$  is above  $V_{IN(EN)}$ . Due to the comparator's hysteresis, switching will not stop until the input falls slightly below  $V_{IN(EN)}$ .

## APPLICATIONS INFORMATION

Alternatively, a resistor divider from an output of another regulator to the enable pin of the LTC3311/LTC3311-X provides event-based power-up sequencing, enabling the LTC3311/LTC3311-X when the output of the other regulator reaches a predetermined level.

### Output Voltage Tracking and Soft-Start

The LTC3311/LTC3311-X allows the user to program its output voltage ramp rate by means of the SSTT pin.

An internal 10 $\mu$ A pulls up the SSTT pin. Putting an external capacitor on SSTT enables soft-starting the output to prevent current surge on the input supply and output voltage overshoot. During the soft-start ramp, the output voltage will proportionally track the SSTT pin voltage. When the soft-start is complete, the pin will servo to a voltage proportional to the LTC3311/LTC3311-X junction temperature. See Figure 3 showing the SSTT pin operating range.

The soft-start time is calculated using Equation 10.

$$t_{SS} = C_{SS} \cdot \frac{500\text{mV}}{10\mu\text{A}} \quad (10)$$

For output tracking applications, SSTT can be externally driven by another voltage source. From 0V to 0.5V, the SSTT voltage will override the internal 0.5V reference input to the error amplifier, thus regulating the FB node voltage to that of SSTT pin. When SSTT is above 0.5V, tracking is disabled and the feedback voltage will regulate to the internal reference voltage.

An active pull-down circuit is connected to the SSTT pin to discharge the external soft-start capacitor in the case of fault conditions. The ramp will restart when the fault is cleared. Fault conditions that clear the soft-start capacitor are the EN/UV pin transitioning low,  $V_{IN}$  voltage falling too low, or thermal shutdown.

### Temperature Monitor

Once the soft-start cycle has completed and the output power good flag thrown, the SSTT pin reports the die junction temperature. The LTC3311/LTC3311-X regulates the SSTT pin to a voltage proportional to the junction temperature. While reporting the temperature, the SSTT

voltage is not valid below 1V. The junction temperature is calculated with Equation 11.

$$T_J (\text{°C}) = \frac{V_{SSTT}}{4\text{mV}} - 273 \quad (11)$$

The following procedure is used for a more accurate measurement of the junction temperature:

1. Measure the ambient temperature  $T_A$ .
2. Measure the SSTT voltage while in pulse-skipping mode with the  $V_{OUT}$  pulled up slightly higher than the regulated  $V_{OUT}$ .
3. Calculate the slope of the temperature sensing circuit with Equation 12.

$$\text{Slope (mV/°C)} = \frac{V_{SSTT}}{T_A + 273} \quad (12)$$

4. Calculate the junction temperature with the new calibrated slope.

When the output voltage goes out of regulation and the power good pin is pulled low, the soft-start pin no longer reports the temperature.

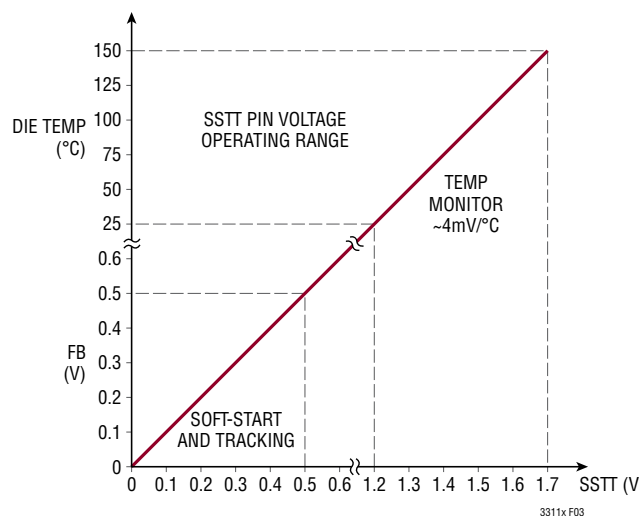

Figure 3. Soft-Start and Temperature Monitor Operation

### Output Power Good

When the LTC3311/LTC3311-X's output voltage is within the  $-2/+10\%$  window of the nominal regulation voltage the output is considered good and the open-drain PGOOD pin

## APPLICATIONS INFORMATION

goes high impedance and is typically pulled high with an external resistor. Otherwise, the internal pull-down device will pull the PGOOD pin low. To prevent glitching, both the upper and lower thresholds include 1% of hysteresis as well as a built in time delay, typically 125 $\mu$ s. The PGOOD pin is also actively pulled low during fault conditions: EN pin is low,  $V_{IN}$  is too low, or in thermal shutdown.

For multiphase applications the PGOOD pin is used for communication between the master and slave phases. Connect the PGOOD pins together and pull-up to  $V_{IN}$  or  $V_{OUT}$  with an external resistor.

### Output Short Circuit Protection and Recovery

The peak inductor current at which the current comparator shuts off the top power switch is controlled by the voltage on the ITH pin. If the output current increases, the error amplifier raises the ITH pin voltage until the average inductor current matches the new load current. In normal operation, the LTC3311/LTC3311-X clamps the maximum ITH pin voltage.

When the output is shorted to ground, the inductor current decays very slowly during the switch off time because of the low voltage across the inductor. To keep the current in control, a secondary limit is also imposed on the valley inductor current. If the inductor current measured through the bottom power switch stays above  $I_{VALLEY(MAX)}$ , the top power switch will be held off and switching cycles will be skipped until the inductor current is reduced.

Recovery from a short circuit can be abrupt and because the output is shorted and below regulation the regulator is requesting the maximum current to charge the output. When the short circuit condition is removed, the inductor current could cause an extreme voltage overshoot in the output. The LTC3311/LTC3311-X addresses this potential issue by regulating the SSTT voltage just above the FB voltage anytime the output is out of regulation. Therefore, a recovery from an output short circuit goes through a soft-start cycle. The output ramp is controlled and the overshoot is minimized.

### Low EMI PCB Layout

The LTC3311/LTC3311-X is specifically designed to minimize EMI/EMC emissions and also to maximize efficiency

when switching at high frequencies. For optimal performance, the LTC3311/LTC3311-X requires the use of multiple  $V_{IN}$  bypass capacitors.

The LTC3311/LTC3311-X does not have any internal bypass capacitors and hence requires three additional 0201 external capacitors ( $C_{IN5}$ ,  $C_{IN6}$ , and  $C_{IN7}$ ), as shown in Figure 4. Place these capacitors as close as possible to the IC.

To avoid noise coupling into FB (LTC3311 only), the resistor divider should be placed near the FB and AGND pins and physically close to the LTC3311. The remote output and ground traces should be routed together as a differential pair to the remote output. These traces should be terminated as close as physically possible to the remote output point that is to be accurately regulated through remote differential sensing.

See Figure 4 for a recommended PCB layout.

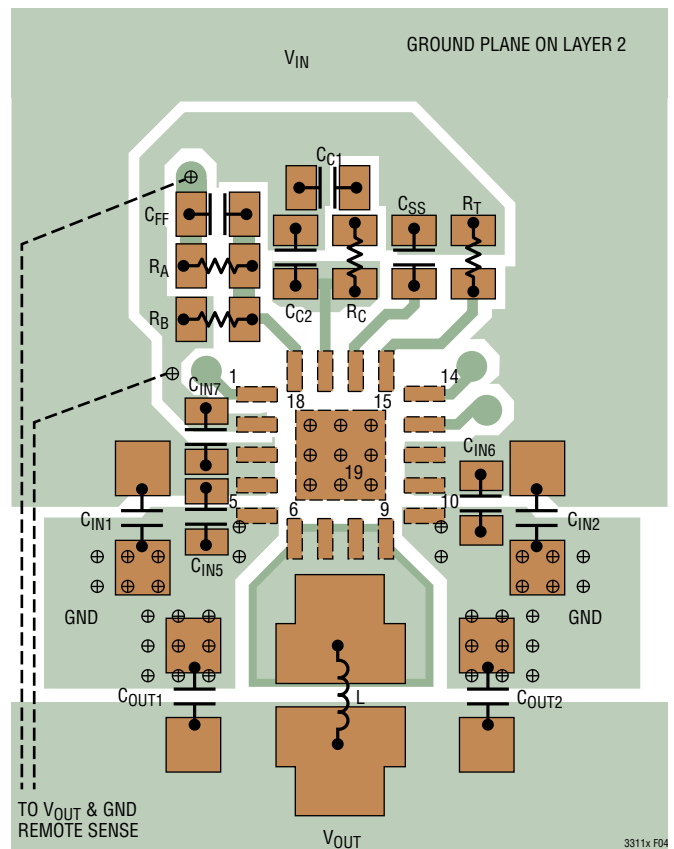

Figure 4. Recommended PCB Layout for the LTC3311

## APPLICATIONS INFORMATION

Large, switched currents flow in the LTC3311/LTC3311-X  $V_{IN}$ , SW and PGND pins and the input capacitors. The loops formed by the input capacitors should be as small as possible by placing the capacitors adjacent to the  $V_{IN}$  and PGND pins. Place the input capacitors, inductor, and output capacitors on the same layer of the circuit board. Place a local, unbroken ground plane under the application circuit on the layer closest to the surface layer.

The SW node should be as short as possible. Finally, keep the FB (LTC3311 only) and RT nodes small and away from the noisy SW node.

### High Temperature Considerations

For higher ambient temperatures, care should be taken in the layout of the PCB to ensure good heat sinking of the LTC3311/LTC3311-X. The PGND pins and the exposed pad on the bottom of the package should be soldered to a ground plane. This ground should be tied to large copper layers below with many thermal vias; these layers will spread heat dissipated by the LTC3311/LTC3311-X. Placing additional vias can reduce thermal resistance further. The maximum load current should be derated as the ambient temperature approaches the maximum junction rating. Power dissipation within the LTC3311/LTC3311-X can be estimated by calculating the total power loss from an efficiency measurement and subtracting the inductor loss. The die temperature is monitored with the SSTT pin.



TYPICAL APPLICATIONS

Three Phase, 2MHz, 0.6V, 37.5A, Forced Continuous Mode

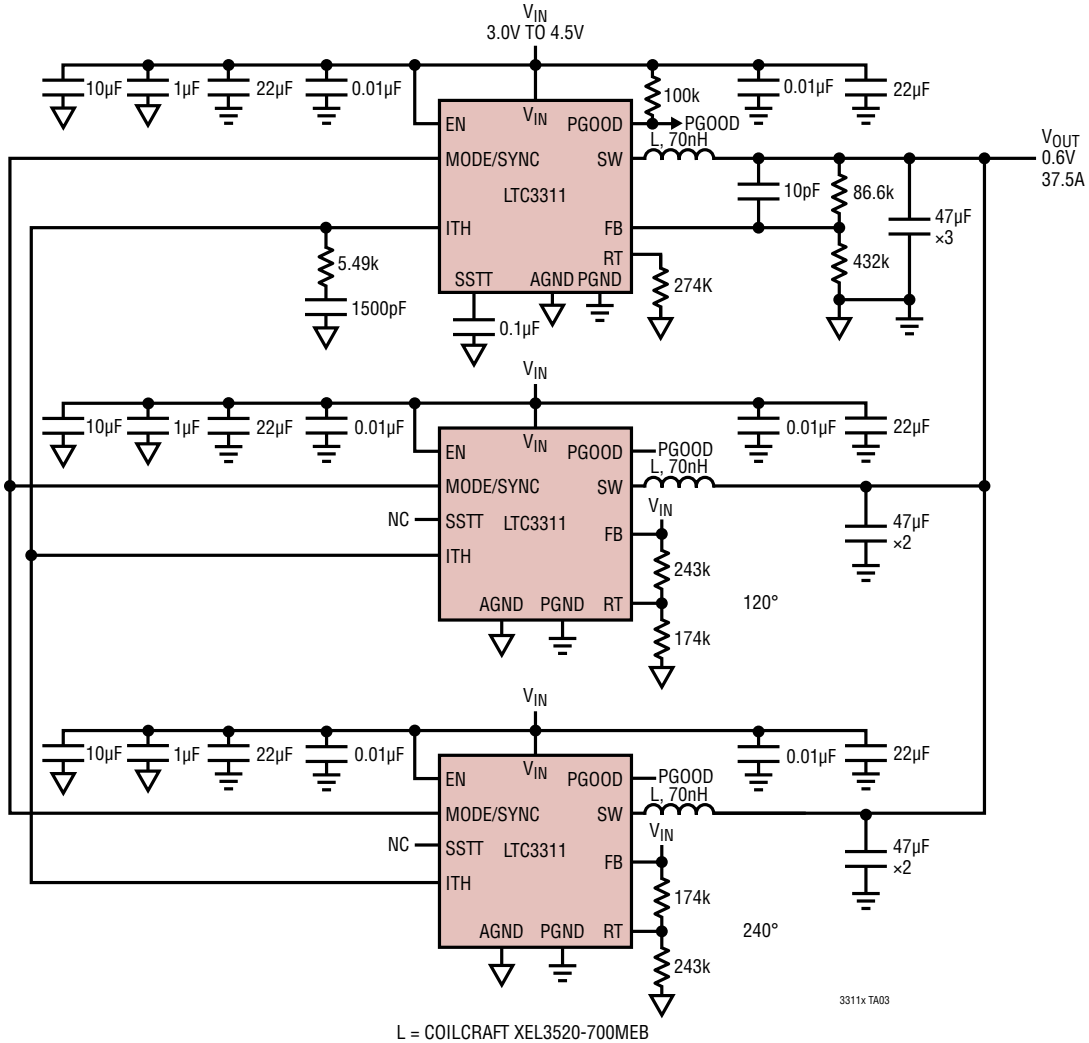

## TYPICAL APPLICATIONS

Four Phase, 2MHz, 1.2V, 50A, Forced Continuous Mode

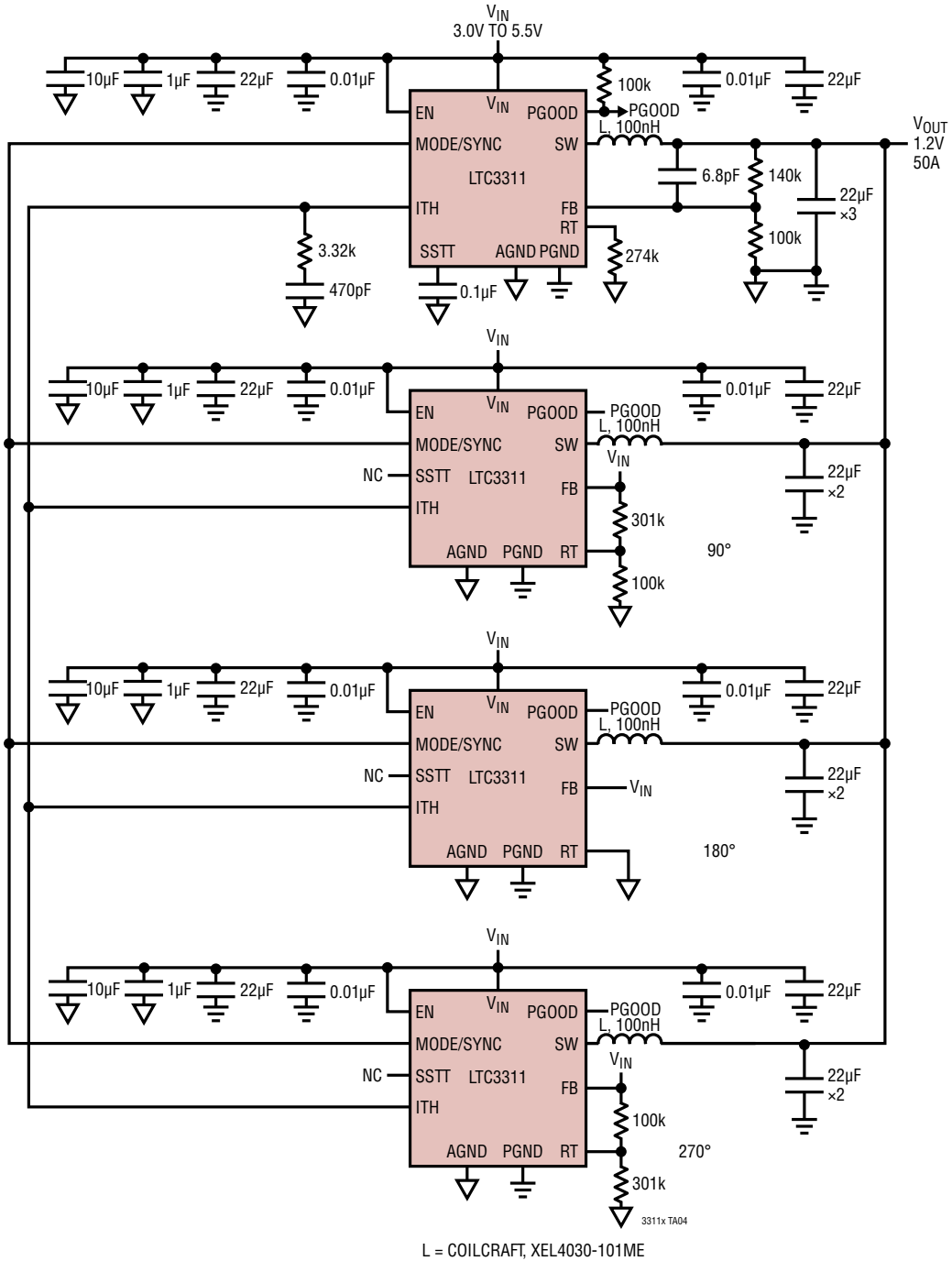



## TYPICAL APPLICATIONS

### 5MHz, 1V, 12.5A, Forced Continuous Mode

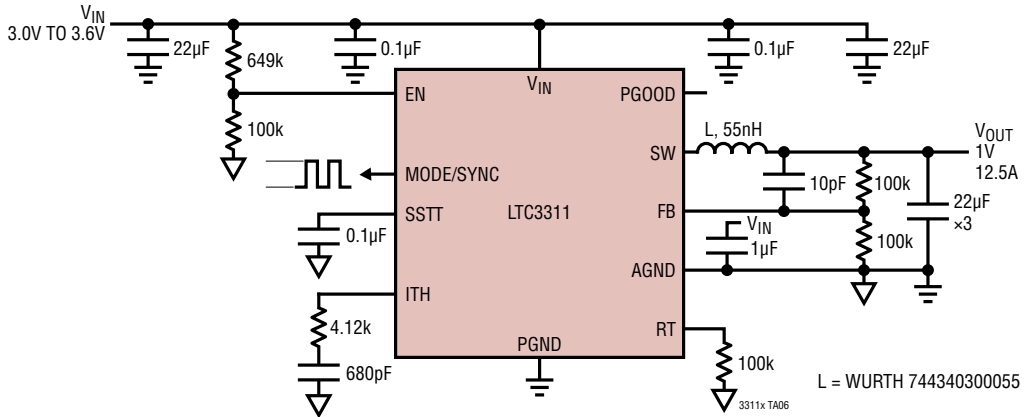

### 2MHz, 3.3V, 12.5A, Pulse-Skipping Mode

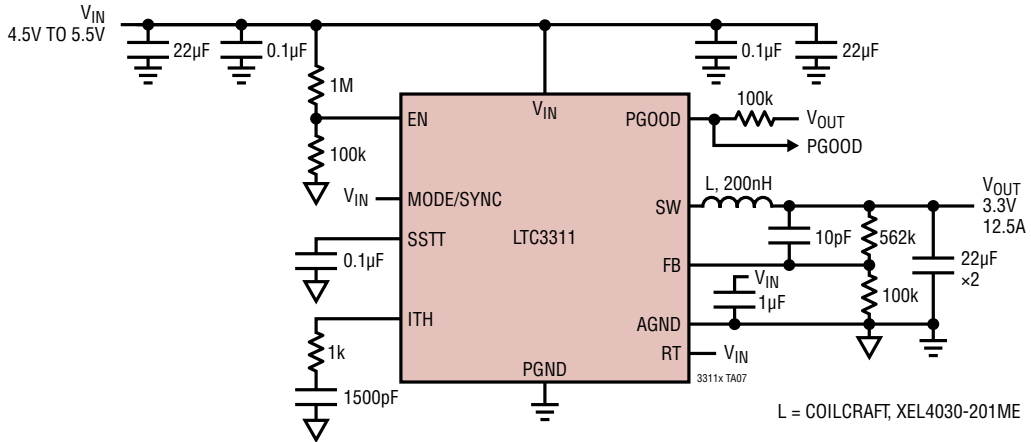

### 2MHz, 0.5V, 12.5A, Forced Continuous Mode, Low Part Count

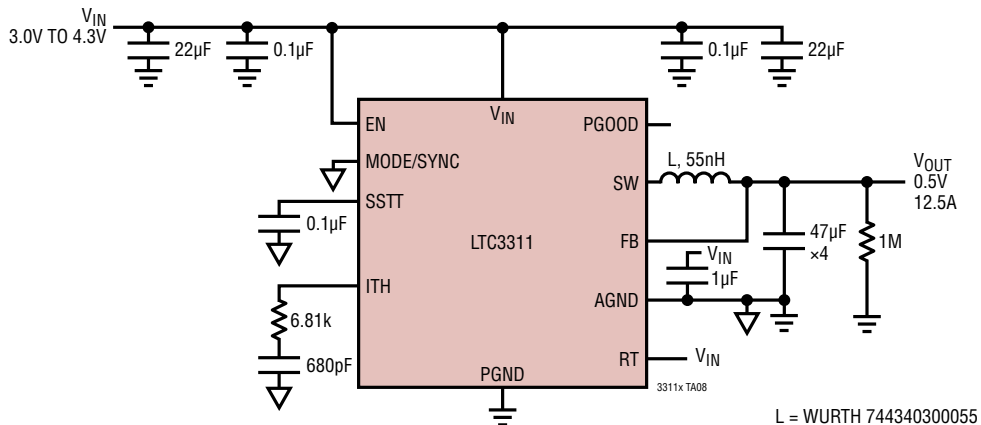

TYPICAL APPLICATIONS

2MHz, 1.0V, Forced Continuous  
1.5A to 7.5A Load Step 6A/μs, ±1.8% V<sub>OUT</sub> Deviation

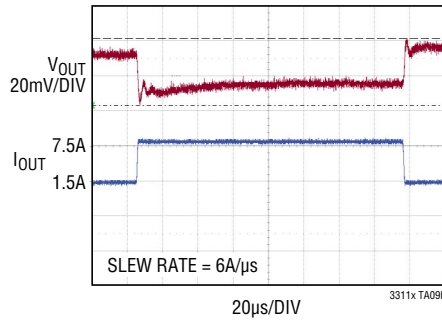
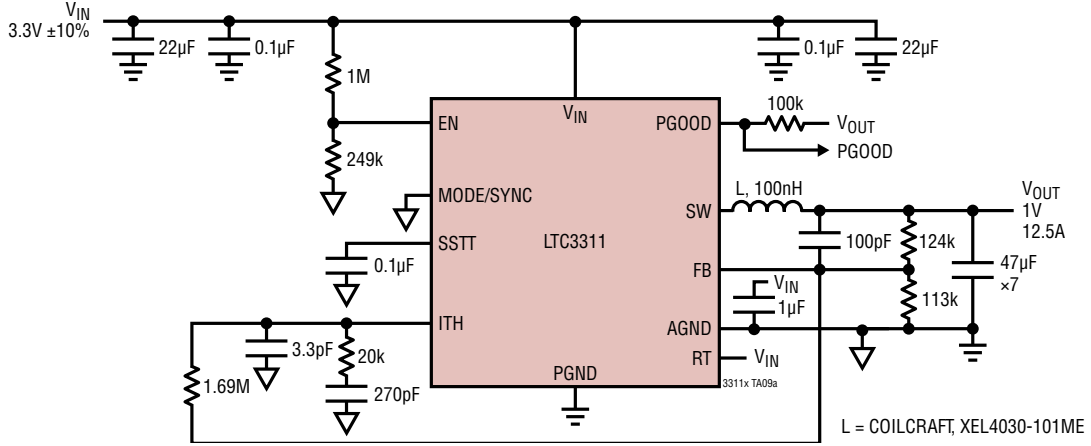

## PACKAGE DESCRIPTION

**LQFN Package**  
**18-Lead (3mm × 3mm × 0.94mm)**  
 (Reference LTC DWG # 05-08-1548 Rev D)

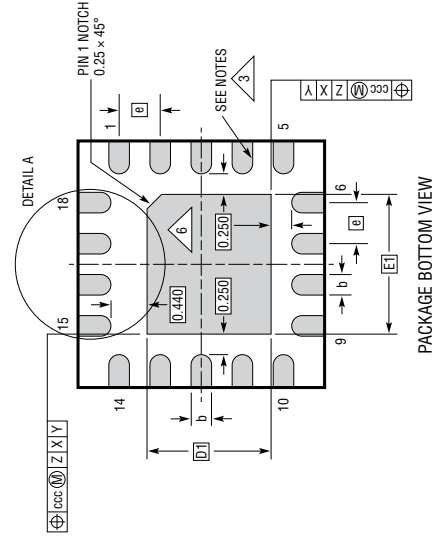

PACKAGE BOTTOM VIEW

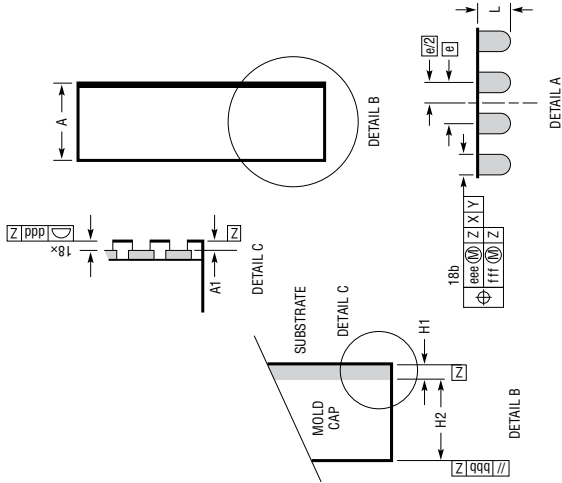

PACKAGE TOP VIEW

DETAIL A

- NOTES:**
1. DIMENSIONING AND TOLERANCING PER ASME Y14.5M-1994
  2. ALL DIMENSIONS ARE IN MILLIMETERS
  3. METAL FEATURES UNDER THE SOLDER MASK OPENING NOT SHOWN SO AS NOT TO OBSCURE THESE TERMINALS AND HEAT FEATURES
  4. DETAILS OF PIN 1 IDENTIFIER ARE OPTIONAL, BUT MUST BE LOCATED WITHIN THE ZONE INDICATED. THE PIN 1 IDENTIFIER MAY BE EITHER A MOLD OR MARKED FEATURE
  5. PRIMARY DATUM - Z - IS SEATING PLANE
  6. THE EXPOSED HEAT FEATURE MAY HAVE OPTIONAL CORNER RADII

DIMENSIONS				
SYMBOL	MIN	NOM	MAX	NOTES
A	0.85	0.94	1.03	
A1			0.03	
L	0.30	0.40	0.50	
b	0.22	0.25	0.28	
D		3.00		
E		3.00		
D1		1.51		
E1		1.70		
e		0.50		
H1		0.24 REF		
H2		0.70 REF		
aaa			0.10	
bbb			0.10	
ccc			0.08	
ddd			0.10	
eee			0.15	
fff			0.08	
SUBSTRATE THK				
MOLD CAP HT				

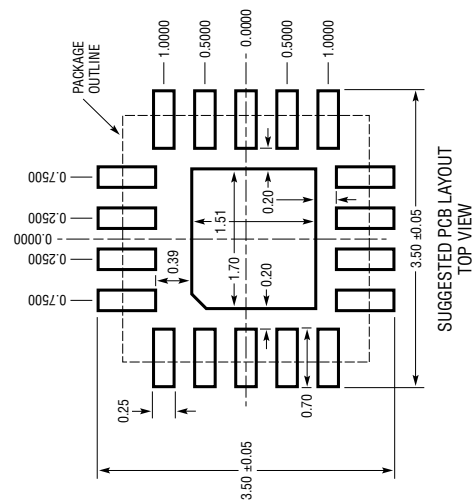

SUGGESTED PCB LAYOUT TOP VIEW

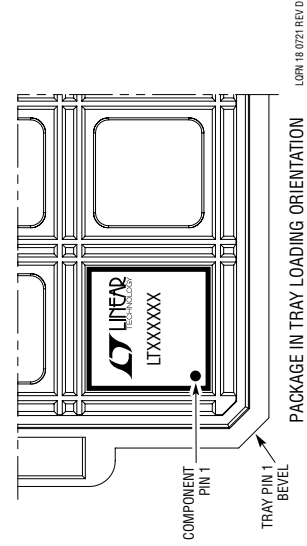

PACKAGE IN TRAY LOADING ORIENTATION

**REVISION HISTORY**

REV	DATE	DESCRIPTION	PAGE NUMBER
A	03/22	Changed Voltage Regulation specs and conditions.	3
		Output Overvoltage Protection section changed 100 $\mu$ s to 125 $\mu$ s.	18
		Output Power Good section changed 100 $\mu$ s to 125 $\mu$ s.	20

## TYPICAL APPLICATION

3MHz, 1.0V, 12.5A, Forced Continuous Mode

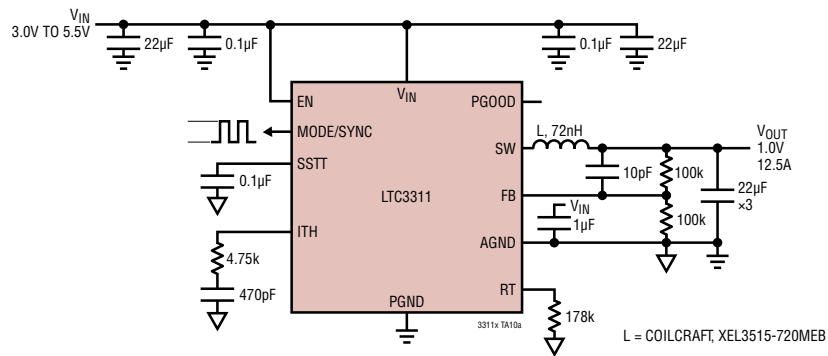

## RELATED PARTS

PART NUMBER	DESCRIPTION	COMMENTS
<a href="#">LTC3311S</a>	5V, 12.5A Synchronous Step-Down Silent Switcher 2	Switching Frequencies Up to 5MHz, Silent Switcher Architecture 2 for Ultralow EMI Emissions, 2.25V to 5.5V Input Operating Range, 0.5V to $V_{IN}$ Output Voltage Range with $\pm 1\%$ Accuracy, PGOOD Indication, $R_T$ Programming, SYNC Input, Configurable for Paralleling Power Stages, Pin Compatible with LTC3310/LTC3310S, 3mm $\times$ 3mm LQFN-18 Package
<a href="#">LTC3310/LTC3310S</a>	5V, 10A Synchronous Step-Down Silent Switcher/Silent Switcher 2	Switching Frequencies Up to 5MHz, Silent Switcher/Silent Switcher 2 Architecture for Ultralow EMI Emissions, 2.25V to 5.5V Input Operating Range, 0.5V to $V_{IN}$ Output Voltage Range with $\pm 1\%$ Accuracy, PGOOD Indication, $R_T$ Programming, SYNC Input, Configurable for Paralleling Power Stages, 150°C Operation (LTC3310), Pin Compatible with LTC3311/LTC3311S, 3mm $\times$ 3mm LQFN-18 Package
<a href="#">LTC3315A/LTC3315B</a>	Dual 5V, 2A Synchronous Step-Down DC/DCs	Dual Monolithic Synchronous Step-Down Voltage Regulators Each Capable of Supplying 2A at Switching Frequencies Up to 3MHz(A) and 10MHz(B), 2.25V to 5.5V Input Operating Range, 0.5V to $V_{IN}$ Output Voltage Range with $\pm 1\%$ Accuracy, PGOOD Indication, SYNC Input, 2mm $\times$ 2mm LQFN-12
<a href="#">LTC3636/LTC3636-1</a>	Dual Channel 6A, 20V Monolithic Synchronous Step-Down Regulator	95% Efficiency, $V_{IN}$ : 3.1V to 20V, $V_{OUT(MIN)} = 0.6V$ (LTC3636), 1.8V (LTC3636-1), $I_Q = 1.3mA$ , $I_{SD} < 13\mu A$ , 4mm $\times$ 5mm QFN-28
<a href="#">LTC3615/LTC3615-1</a>	Dual Channel 5.5V, 3A ( $I_{OUT}$ ), 4MHz, Synchronous Step-Down DC/DC Converter	94% Efficiency, $V_{IN}$ : 2.25V to 5.5V, $V_{OUT(MIN)} = 0.6V$ , $I_Q = 130\mu A$ , $I_{SD} < 1\mu A$ , 4mm $\times$ 4mm QFN-24 Package
<a href="#">LTC3614/LTC3616</a>	5.5V, 4A/6A ( $I_{OUT}$ ), 4MHz, Synchronous Step-Down DC/DC Converter with Tracking and DDR	95% Efficiency, $V_{IN}$ : 2.25V to 5.5V, $V_{OUT(MIN)} = 0.6V$ , $I_Q = 75\mu A$ , $I_{SD} < 1\mu A$ , 3mm $\times$ 5mm QFN-24 Package
<a href="#">LTC3612</a>	5.5V, 3A ( $I_{OUT}$ ), 4MHz, Synchronous Step-Down DC/DC Converter	95% Efficiency, $V_{IN}$ : 2.25V to 5.5V, $V_{OUT(MIN)} = 0.8V$ , $I_Q = 60\mu A$ , $I_{SD} < 1\mu A$ , TSSOP-16E and 4mm $\times$ 4mm QFN-16 Packages
<a href="#">LTC7150S</a>	20V, 20A Synchronous Step-Down Silent Switcher 2 Regulator	92% Efficiency, $V_{IN}$ : 3.1V to 20V, $V_{OUT(MIN)} = 0.6V$ , $I_Q = 2mA$ , $I_{SD} \leq 40\mu A$ , Differential Remote Sense, 6mm $\times$ 5mm BGA
<a href="#">LT<sup>®</sup>8642S</a>	18V, 10A Synchronous Step-Down Silent Switcher 2 Regulator	96% Efficiency, $V_{IN}$ : 2.8V to 18V, $V_{OUT(MIN)} = 0.6V$ , $I_Q = 240\mu A$ , $I_{SD} < 1\mu A$ , 4mm $\times$ 4mm LQFN-24
<a href="#">LT8640S</a>	42V, 6A Synchronous Step-Down Silent Switcher 2 with 2.5µA Quiescent Current	96% Efficiency, $V_{IN}$ : 3.4V to 42V, $V_{OUT(MIN)} = 1.0V$ , $I_Q = 230\mu A$ , $I_{SD} < 1\mu A$ , 4mm $\times$ 4mm LQFN-24
<a href="#">LT8650S</a>	Dual Channel 4A, 42V, Synchronous Step-Down Silent Switcher 2 with 6.2µA Quiescent Current	94.5% Efficiency, $V_{IN}$ : 3V to 42V, $V_{OUT(MIN)} = 0.8V$ , $I_Q = 5mA$ , $I_{SD} < 2\mu A$ , 4mm $\times$ 6mm LQFN-32
<a href="#">LTC7151S</a>	20V, 15A Synchronous Step-Down Silent Switcher 2 Regulator	92.5% Efficiency, $V_{IN}$ : 3.1V to 20V, $V_{OUT(MIN)} = 0.5V$ , $I_Q = 2mA$ , $I_{SD} < 20\mu A$ , 4mm $\times$ 5mm LQFN-28
<a href="#">LTC3307A/LTC3307B</a> , <a href="#">LTC3308A/LTC3308B</a> , <a href="#">LTC3309A/LTC3309B</a>	3A, 4A and 6A 5V Synchronous Step-Down Silent Switcher DC/DC	Monolithic Synchronous Step-Down DC/DC Capable of Supplying up to 6A at Switching Frequencies Up to 3MHz(A) and 10MHz(B), Silent Switcher Architecture for Ultralow EMI Emissions, 2.25V to 5.5V Input Operating Range, 0.5V to $V_{IN}$ Output Voltage Range with $\pm 1\%$ Accuracy, PGOOD Indication, $R_T$ Programming, SYNC Input, 2mm $\times$ 2mm LQFN-12

## Looking for pricing, stock, or lifecycle information?

Click below to explore more details on WIN SOURCE:

 [View LTC3311JV#PBF on WIN SOURCE](#)

 [Analog Devices Inc. Information](#)

## Optimize Your Supply Chain with WIN SOURCE Solutions

-  Global Sourcing Solution
-  Obsolete Management
-  Cost Control Management
-  Shortage Management
-  Alternative Solution
-  Excess Inventory Management