



**THE DATASHEET OF
LTC3816IUHF#PBF**



Single-Phase Wide V_{IN} Range DC/DC Controller for Intel IMVP-6/IMVP-6.5 CPUs

FEATURES

- Supports 7-Bit IMVP-6/IMVP-6.5 VID Code and Features
- Wide V_{IN} Range: 4.5V to 36V Operation with Optional Line Feedforward Compensation
- $t_{ON(MIN)} < 35ns$, Capable of Very Low Duty Cycle
- Temperature Compensated Inductor DCR or Sense Resistor Output Current Monitoring
- Differential Remote Output Voltage Sensing with Programmable Active Voltage Positioning
- Phase-Lockable Fixed Frequency: 150kHz to 550kHz
- Programmable UVLO, Preset V_{OUT} at Boot-Up
- Programmable Slow Slew Rate Sleep State Exit
- Internal LDO for Single Supply Operation
- Overvoltage and Overcurrent Protection
- PWRGD and $VRTT\#$ Thermal Throttling Flags
- Power Optimization During Sleep and Light Load
- 38-Pin Thermally Enhanced eTSSOP and 5mm × 7mm QFN Packages

APPLICATIONS

- Embedded Computing
- Mobile Computers, Internet Devices
- Navigation Displays

DESCRIPTION

The LTC[®]3816 is a single-phase synchronous step-down DC/DC switching regulator controller that drives N-channel power MOSFETs in a constant-frequency voltage mode architecture. The controller's leading edge modulation topology allows extremely low output voltages and supports a phase-lockable switching frequency up to 550kHz. The output voltage is programmed using a 7-bit VID code.

The LTC3816 features all of the IMVP-6/IMVP-6.5 requirements, including start-up to a preset boot voltage, differential remote output voltage sensing with programmable active voltage positioning, I_{MON} output current reporting, power optimization during sleep state, and fast or slow slew rate sleep state exit.

Fault protection features include input undervoltage lockout, cycle-by-cycle current limit, output overvoltage protection, and PWRGD and overtemperature flags.

LT, LT, LTC, LTM, Linear Technology and the Linear logo are registered trademarks and R_{SENSE} is a trademark of Linear Technology Corporation. All other trademarks are the property of their respective owners. Protected by U.S. Patents, including 5408150, 5055767, 5481178, 6580258.

TYPICAL APPLICATION

High Efficiency, Synchronous IMVP-6/ IMVP-6.5 Step-Down Controller

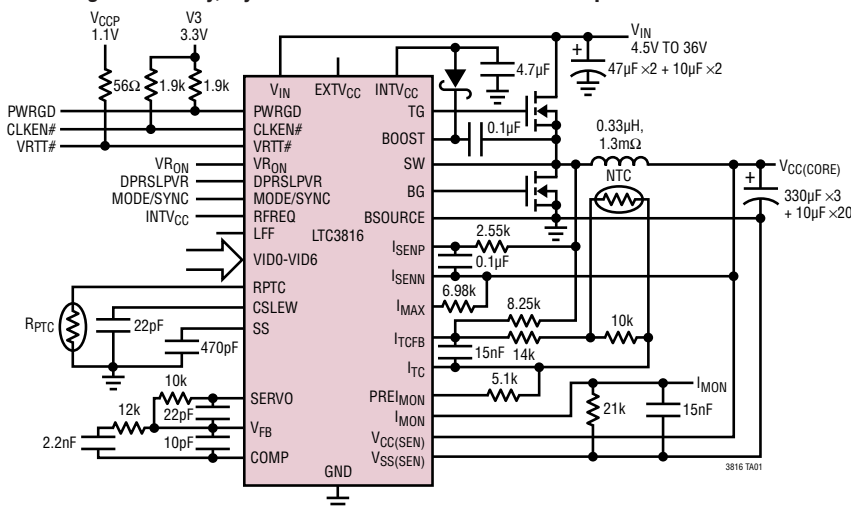

Efficiency and Power Loss vs Load Current

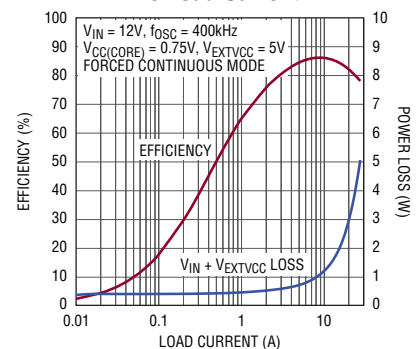

ABSOLUTE MAXIMUM RATINGS (Notes 1, 8)

Input Supply Voltage (V_{IN})	-0.3V to 40V	DPRSLPVR, VRTT#	-0.3V to 3.3V
Topside Driver Voltage (BOOST)	-0.3V to 46V	$V_{SS(SEN)}$, BSOURCE	-0.3V to 0.3V
Switch Voltage (SW)	-5V to 40V	INTV _{CC} RMS Output Current	50mA
INTV _{CC} , EXTV _{CC} , (BOOST-SW)	-0.3V to 6V	Operating Junction Temperature Range	(Note 3) -40°C to 125°C
I_{SENN} , I_{TCFB} , PRE _{MON} , I_{MON} , RPTC, V_{RON} , $V_{CC(SEN)}$, V_{FB} , SS, VID _n , RFREQ, MODE/SYNC, LFF, I_{SENP} , I_{MAX}	-0.3V to INTV _{CC} + 0.3V	Storage Temperature Range	-65°C to 125°C
PWRGD, CLKEN#	-0.3V to 6V	Lead Temperature (Soldering, 10sec)	eTSSOP
			300°C

PIN CONFIGURATION

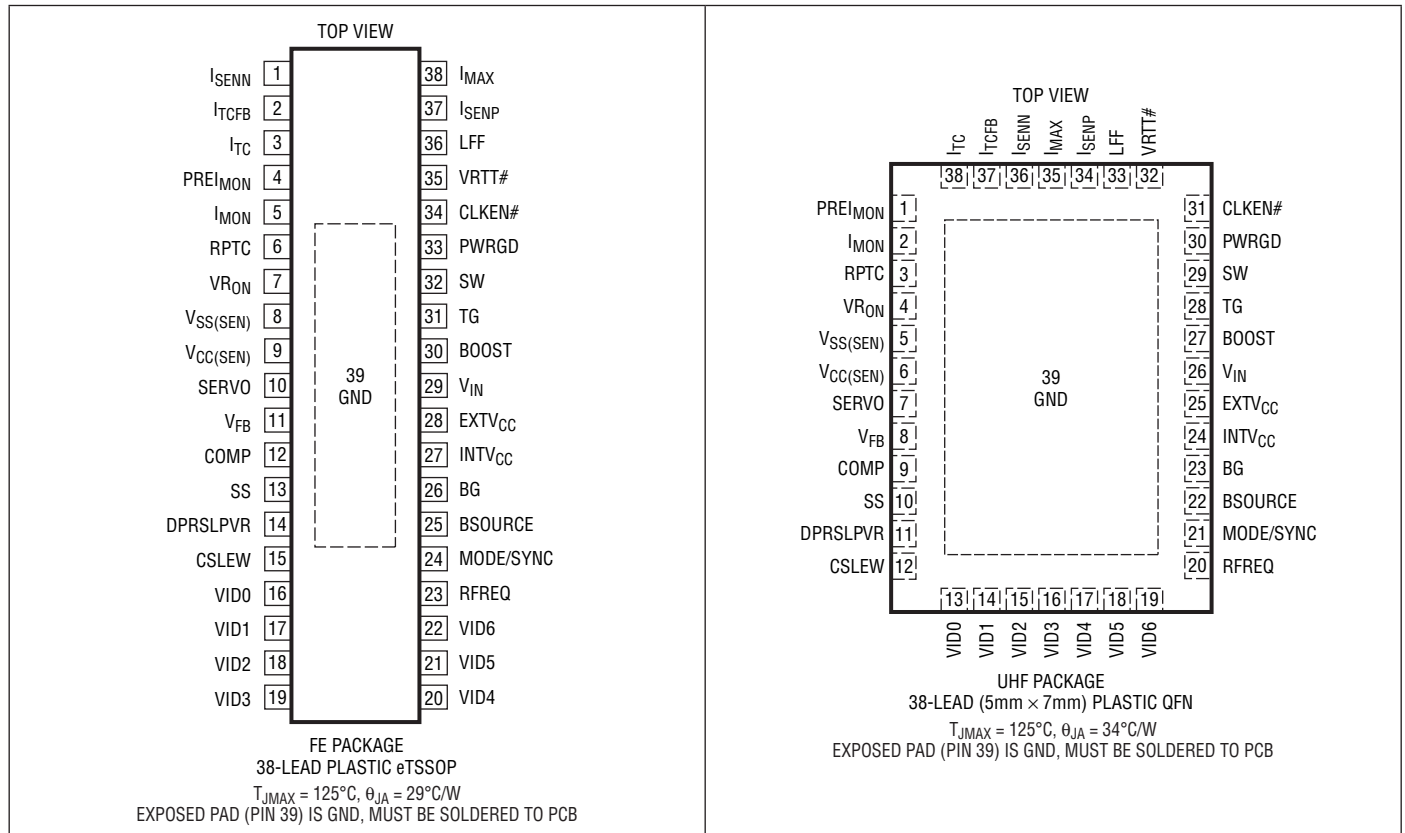

ORDER INFORMATION

LEAD FREE FINISH	TAPE AND REEL	PART MARKING*	PACKAGE DESCRIPTION	TEMPERATURE RANGE
LTC3816EFE#PBF	LTC3816EFE#TRPBF	LTC3816FE	38-Lead Plastic eTSSOP	-40°C to 125°C
LTC3816IFE#PBF	LTC3816IFE#TRPBF	LTC3816FE	38-Lead Plastic eTSSOP	-40°C to 125°C
LTC3816EUHF#PBF	LTC3816EUHF#TRPBF	3816	38-Lead (5mm × 7mm) Plastic QFN	-40°C to 125°C
LTC3816IUHF#PBF	LTC3816IUHF#TRPBF	3816	38-Lead (5mm × 7mm) Plastic QFN	-40°C to 125°C

Consult LTC Marketing for parts specified with wider operating junction temperature ranges.

*The temperature grade is identified by a label on the shipping container.

For more information on lead free part marking, go to: <http://www.linear.com/leadfree/>

For more information on tape and reel specifications, go to: <http://www.linear.com/tapeandreel/>

ELECTRICAL CHARACTERISTICS

The ● denotes the specifications which apply over the full operating junction temperature range, otherwise specifications are at $T_A = 25^\circ\text{C}$. $V_{IN} = 12\text{V}$, $\text{BSOURCE} = \text{EXTV}_{CC} = 0\text{V}$, $\text{VR}_{ON} = 5\text{V}$, unless otherwise noted. (Notes 2, 3)

SYMBOL	PARAMETER	CONDITIONS	MIN	TYP	MAX	UNITS
Supply Input and INTV_{CC} Linear Regulator						
V_{IN}	V_{IN} Supply Voltage Range	$V_{INTVCC} > V_{UVLO}$	● 4.5		36	V
I_{VIN}	V_{IN} Supply Current Normal Mode Shutdown	$V_{BOOST} = V_{INTVCC}$, $f_{OSC} = 400\text{kHz}$ (Note 4) $\text{VR}_{ON} = 0\text{V}$		11 27	100	mA μA
INTV_{CC}	Internal V_{CC} Voltage		● 4.9	5.2	5.5	V
$V_{\text{INTVCC(LINE)}}$	Line Regulation	$7.5\text{V} < V_{IN} < 36\text{V}$			±1.0	%
$V_{\text{INTVCC(LOAD)}}$	Load Regulation	Load = 0mA to 20mA		-0.25	-1.0	%
V_{EXTVCC}	EXTV_{CC} Switchover Voltage	EXTV_{CC} Ramping Positive	4.25	4.50	4.75	V
$V_{\text{EXTVCC(HYS)}}$	EXTV_{CC} Hysteresis			0.4		V
$V_{\text{EXTVCC(DROP)}}$	EXTV_{CC} Voltage Drop	Load = 20mA, $V_{\text{EXTVCC}} = 5\text{V}$		40	100	mV
V_{UVLO}	INTV_{CC} Undervoltage Reset Undervoltage Hysteresis	INTV_{CC} Ramping Positive	3.7	3.9	4.1	V
				0.4		V
Switcher Control Loop						
$V_{CC(\text{CORE})}$	$V_{CC(\text{CORE})} = (V_{CC(\text{SEN})} - V_{SS(\text{SEN})})$	$V_{CC(\text{CORE})} > 0.75\text{V}$ (Note 5) $0.5\text{V} \leq V_{CC(\text{CORE})} \leq 0.75\text{V}$ (Note 5) $0.3\text{V} \leq V_{CC(\text{CORE})} < 0.5\text{V}$ (Note 5)	● ● ●		±0.75 ±6 ±10	% mV mV
$\Delta V_{CC(\text{CORE})}$	$V_{CC(\text{CORE})}$ Voltage Line Regulation	$V_{IN} = 7.5\text{V}$ to 36V (Note 5)		±0.002		%/V
A_{EA}	Error Amplifier DC Gain	No load		80		dB
f_{BW}	Error Amplifier Unity-Gain Bandwidth	(Note 6)		20		MHz
I_{COMP}	Error Amplifier Output Source Current Error Amplifier Output Sink Current	$V_{COMP} = 0\text{V}$ $V_{COMP} = 5\text{V}$		5	-1.5	mA mA
$I_{VCC(\text{SEN})}$	$V_{CC(\text{SEN})}$ Input Current	$V_{ISENN} = V_{CC(\text{SEN})}$, $0\text{V} \leq V_{CC(\text{SEN})} \leq 1.5\text{V}$			±30	μA
$I_{VSS(\text{SEN})}$	$V_{SS(\text{SEN})}$ Input Current	$V_{SS(\text{SEN})} = 0\text{V}$			-60	μA
I_{VFB}	V_{FB} Input Current	$0\text{V} \leq V_{FB} \leq 2\text{V}$			±0.1	μA
I_{ITCFB}	I_{TCFB} Input Current	$0\text{V} \leq V_{ITCFB} \leq 1.5\text{V}$			±0.1	μA

ELECTRICAL CHARACTERISTICS

The ● denotes the specifications which apply over the full operating junction temperature range, otherwise specifications are at $T_A = 25^\circ\text{C}$. $V_{IN} = 12\text{V}$, $\text{BSOURCE} = \text{EXTV}_{CC} = 0\text{V}$, $\text{VR}_{ON} = 5\text{V}$, unless otherwise noted. (Notes 2, 3)

SYMBOL	PARAMETER	CONDITIONS	MIN	TYP	MAX	UNITS
V_{BOOT}	Core Supply Start-Up Voltage	$V_{IMON} = \text{INTV}_{CC}$ (IMVP-6 Configuration) $V_{IMON} < 1.1\text{V}$ (IMVP-6.5 Configuration)		1.2 1.1		V V
V_{OVF}	Overvoltage Fault Threshold	$V_{IMON} = \text{INTV}_{CC}$ (IMVP-6 Configuration) $V_{IMON} < 1.1\text{V}$ (IMVP-6.5 Configuration)	● ●	1.65 1.53	1.7 1.55	V V
I_{SS}	SS Pull-Up Current	$V_{SS} = 0\text{V}$		-1		μA
I_{CSLEW}	CSLEW Pull-Up Current	$V_{CSLEW} = 0\text{V}$ IMVP-6 and $V_{DPRSLPVR} = \text{INTV}_{CC}$ IMVP-6.5 or $V_{DPRSLPVR} = 0\text{V}$		-10 -40		μA μA
I_{RPTC}	RPTC Source Current	$RPTC = 0\text{V}$	-90	-100	-110	μA
V_{RPTC}	RPTC Thermal Shutdown Threshold			0.47		V
I_{MAX}	I_{MAX} Source Current	$V_{IMAX} = 0\text{V}$, 1x Current Limit Duration $V_{IMAX} = 0\text{V}$, 2x Current Limit Duration	●	-9 -20	-11	μA μA
t_{IMAX2x}	2x Current Limit Duration 2x Current Limit Period		35	45 630		μs μs
V_{ILIM}	Current Comparator Offset	$V_{IMAX} = 1.0\text{V}$, $V_{ILIM} = V_{ISENP} - V_{IMAX}$			± 3	mV
V_{IREV}	Reverse-Current Comparator Offset	$V_{ISENN} = 1.0\text{V}$, $V_{IREV} = V_{ISENP} - V_{ISENN}$			± 2	mV
I_{ISENP}	I_{SENP} Input Current	$0\text{V} \leq V_{ISENP} \leq 1.5\text{V}$			± 1	μA
I_{ISENN}	I_{SENN} Input Current	$0\text{V} \leq V_{ISENN} \leq 1.5\text{V}$			± 20	μA
V_{IMON}	IMVP-6/IMVP-6.5 Selection Threshold			2.4		V
I_{VRON}	Regulator On Source Current	$\text{VR}_{ON} = 0\text{V}$		-1		μA
VR_{ON}	Regulator On Threshold Regulator Power-Down Threshold	Rising Edge Falling Edge	1.18	1.2 0.65	1.22	V V

Oscillator and Drivers

f_{OSC}	Oscillator Frequency	RFREQ Floats $V_{RFREQ} = 0\text{V}$ $V_{RFREQ} = 2.5\text{V}$		375 180 530	400 210 580	425 240 640	kHz kHz kHz
f_{SYNC}	Minimum Synchronization Input Frequency Maximum Synchronization Input Frequency			550		150	kHz kHz
V_{SYNC}	MODE/SYNC Synchronization Threshold				1.6		V
I_{RFREQ}	RFREQ Source Current	$V_{RFREQ} = 0\text{V}$	-9	-10	-11		μA
V_{MODE}	MODE/SYNC Force Continuous Threshold	$V_{IMON} = \text{INTV}_{CC}$ (IMVP-6 Configuration) $V_{IMON} < 1.1\text{V}$ (IMVP-6.5 Configuration)		1.6 0.5			V V
DC_{MAX}	Maximum TG Duty Cycle	MODE/SYNC = 0, RFREQ Floats			90		%
$t_{ON(MIN)}$	TG Minimum Pulse Width	(Note 6)			35		ns
t_{DEAD}	Driver Dead-Time				30		ns
TG R_{UP}	TG Driver Pull-Up On-Resistance	TG High, $I_{OUT} = -100\text{mA}$ (Note 7)			2.6		Ω
TG R_{DOWN}	TG Driver Pull-Down On-Resistance	TG Low, $I_{OUT} = 100\text{mA}$ (Note 7)			1.2		Ω
BG R_{UP}	BG Driver Pull-Up On-Resistance	BG High, $I_{OUT} = -100\text{mA}$ (Note 7)			2.6		Ω
BG R_{DOWN}	BG Driver Pull-Down On-Resistance	BG Low, $I_{OUT} = 100\text{mA}$ (Note 7)			0.9		Ω

ELECTRICAL CHARACTERISTICS

The ● denotes the specifications which apply over the full operating junction temperature range, otherwise specifications are at $T_A = 25^\circ\text{C}$. $V_{IN} = 12\text{V}$, $\text{BSOURCE} = \text{EXTV}_{\text{CC}} = 0\text{V}$, $\text{VR}_{\text{ON}} = 5\text{V}$, unless otherwise noted. (Notes 2, 3)

SYMBOL	PARAMETER	CONDITIONS	MIN	TYP	MAX	UNITS	
VID, DPRSLPVR, LFF Parameters							
$V_{\text{IL(VID)}}$	VID Input Low Threshold				0.3	V	
$V_{\text{IH(VID)}}$	VID Input High Threshold		0.7			V	
I_{VID}	VID Input Leakage Current	$0\text{V} \leq V_{\text{VID}} \leq 5\text{V}$			± 1	μA	
V_{DPRSLPVR}	DPRSLPVR Input Threshold	$V_{\text{IMON}} = \text{INTV}_{\text{CC}}$ (IMVP-6 Configuration)		1.6		V	
I_{LFF}	LFF Pull-Up Current	$V_{\text{LFF}} = 0\text{V}$		-1		μA	
V_{LFF}	LFF Input Threshold			1		V	
PWRGD, CLKEN#, VRTT#							
V_{PWRGD}	Positive Power Good Threshold Negative Power Good Threshold	With Respect to VID $V_{\text{CC(CORE)}}$	150 -240	175 -270	200 -300	mV mV	
I_{LEAK}	PWRGD, CLKEN# Leakage Current VRTT# Leakage Current	$V_{\text{PWRGD}} = V_{\text{CLKEN\#}} = 5\text{V}$ $V_{\text{VRTT\#}} = 3.3\text{V}$			10 100	μA μA	
V_{OL}	PWRGD, CLKEN# Output Low Voltage VRTT# Output Low Voltage	$I_{\text{OUT}} = 2\text{mA}$ $I_{\text{OUT}} = 20\text{mA}$		0.1 0.075	0.3 0.18	V V	
t_{PWRGD}	PWRGD Glitch Filter	Power Good to Power Bad		750		μs	
$t_{\text{CLKEN\#}}$	CLKEN# Falling Edge Delay	Rising V_{BOOT} Edge to CLKEN# Falling Edge	●	50	75	100	μs
$t_{\text{CLK(PWRGD)}}$	CLKEN# to PWRGD Rising Edge Delay		●	5	10	20	ms
$t_{\text{VR(PWRGD)}}$	VR_{ON} to PWRGD Falling Edge Delay	VR_{ON} Falling Edge			100	ns	

Note 1: Stresses beyond those listed under Absolute Maximum Ratings may cause permanent damage to the device. Exposure to any Absolute Maximum Rating condition for extended periods may affect device reliability and lifetime.

Note 2: All currents into device pins are positive; all currents out of device pins are negative. All voltages are referenced to ground unless otherwise specified.

Note 3: The LTC3816 is tested under pulse load conditions such that $T_J \approx T_A$. The LTC3816E is guaranteed to meet performance specifications from 0°C to 85°C . Specifications over the -40°C to 125°C operating junction temperature range are assured by design, characterization and correlation with statistical process controls. LTC3816I specifications are guaranteed over the full -40°C to 125°C operating junction temperature range. Note that the maximum ambient temperature consistent with these specifications is determined by specific operating conditions in conjunction with board layout, the rated package thermal impedance and other environmental factors. T_J is calculated from the ambient temperature, T_A , and power dissipation, P_D , according to the following formula,

$$\text{LTC3816EFE: } T_J = T_A + (P_D \cdot 29^\circ\text{C/W})$$

$$\text{LTC3816EUHF: } T_J = T_A + (P_D \cdot 34^\circ\text{C/W})$$

Note 4: The dynamic input supply current is a function of the power MOSFET gate charging ($Q_G \cdot f_{\text{OSC}}$). See Applications Information for more information.

Note 5: The LTC3816 is measured in a feedback loop that adjusts $V_{\text{CC(SEN)}} - V_{\text{SS(SEN)}}$ to achieve a specified COMP pin voltage. The AITC amplifier is configured as an inverter with gain = -1.

Note 6: Guaranteed by design, not subject to test.

Note 7: On-resistance limit is guaranteed by design and correlation with statistical process controls.

Note 8: The LTC3816 includes overtemperature protection that is intended to protect the device during momentary overload conditions. The maximum rated junction temperature will be exceeded when this protection is active. Continuous operation above the specified absolute maximum operating junction temperature may impair device reliability or permanently damage the device.

TYPICAL PERFORMANCE CHARACTERISTICS

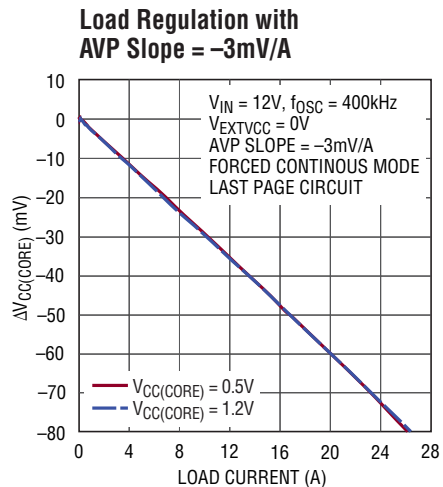
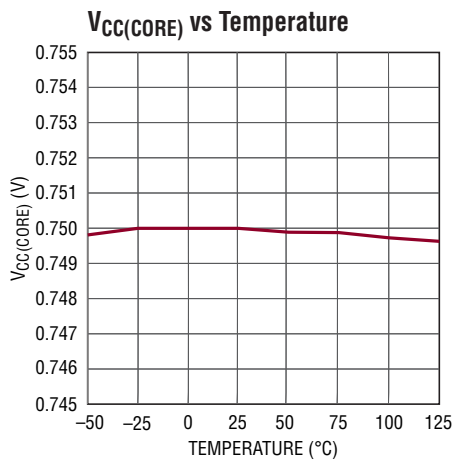
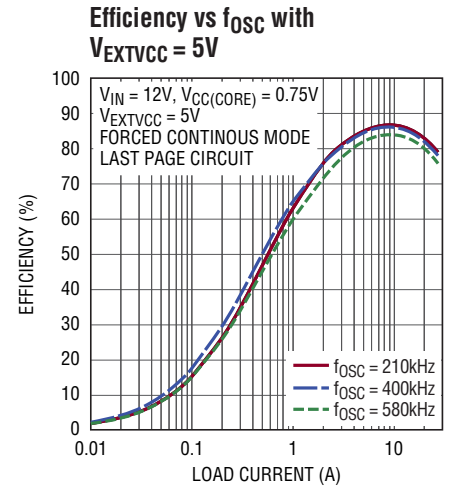
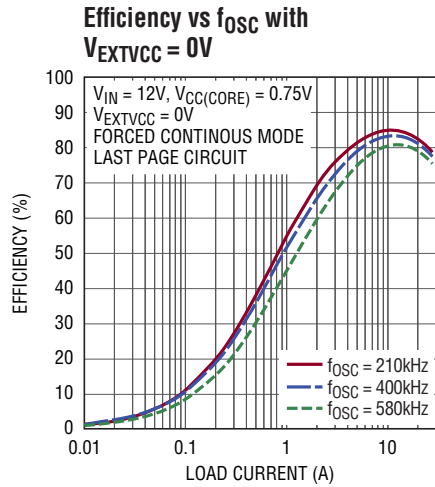
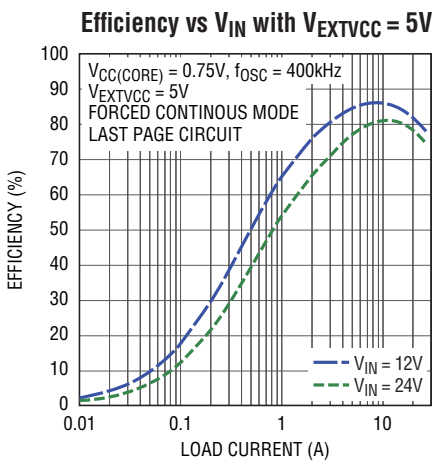
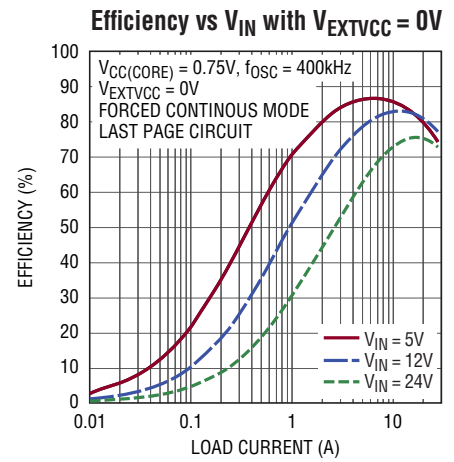
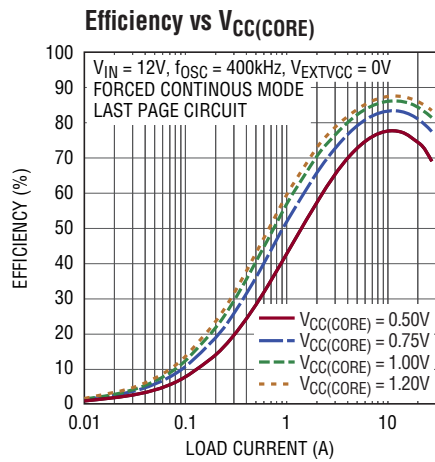
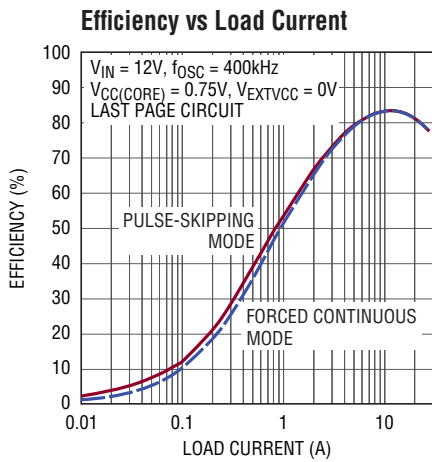

TYPICAL PERFORMANCE CHARACTERISTICS

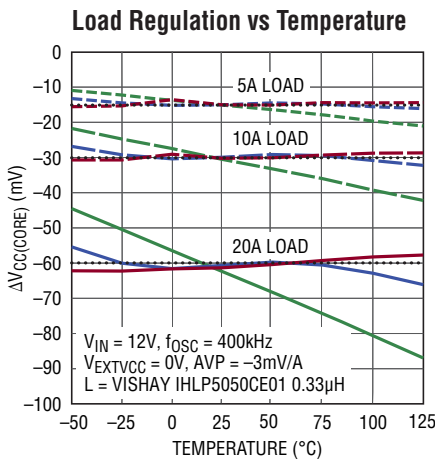

— PTC CONFIGURATION (FIGURE 12)
 $R_{LPTC} = VISHAY TFPT1206L1002FV$
 $R_{VDCRP} = 23.2k, C_{VDCRP} = 10nF$
 — NTC CONFIGURATION,
 LAST PAGE CIRCUIT
 — NO TEMPERATURE COMPENSATION
 LAST PAGE CIRCUIT, REPLACE NTC
 WITH 10k RESISTOR
 ····· IDEAL VALUE

3816 G09

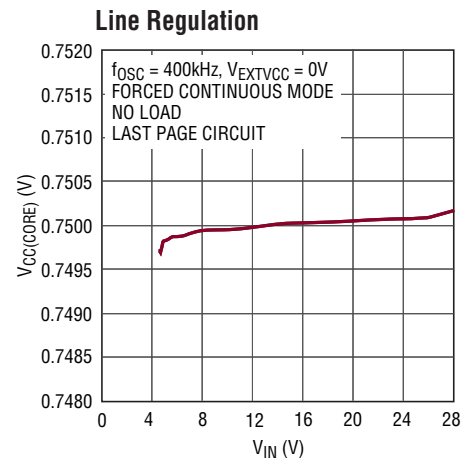

3816 G10

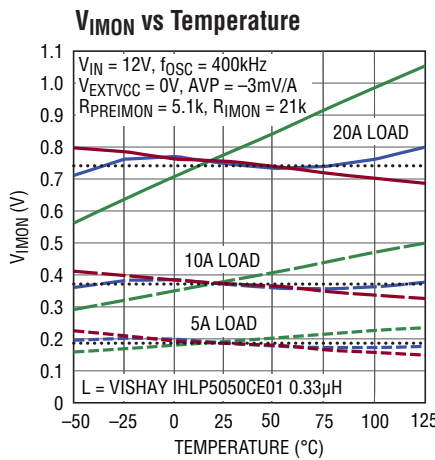

— PTC CONFIGURATION (FIGURE 12)
 $R_{LPTC} = VISHAY TFPT1206L1002FV$
 $R_{VDCRP} = 23.2k, C_{VDCRP} = 10nF$
 — NTC CONFIGURATION,
 LAST PAGE CIRCUIT
 — NO TEMPERATURE COMPENSATION
 LAST PAGE CIRCUIT, REPLACE NTC
 WITH 10k RESISTOR
 ····· IDEAL VALUE

3816 G11

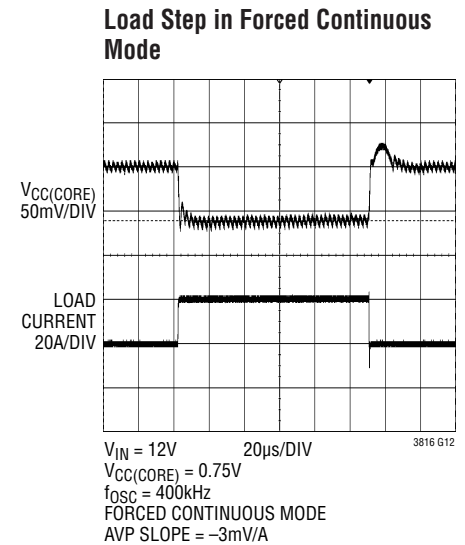

3816 G12

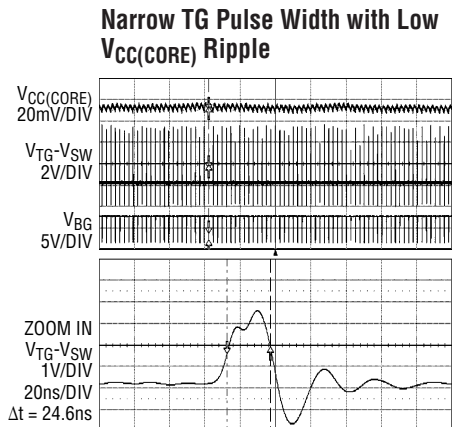

3816 G13

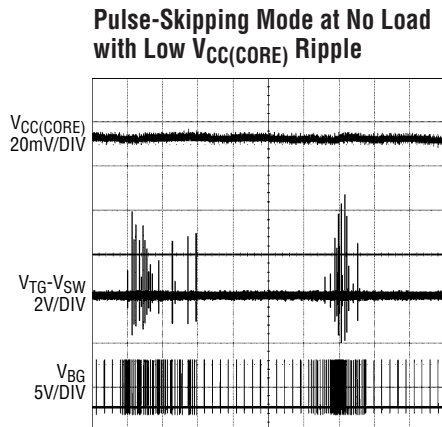

3816 G14

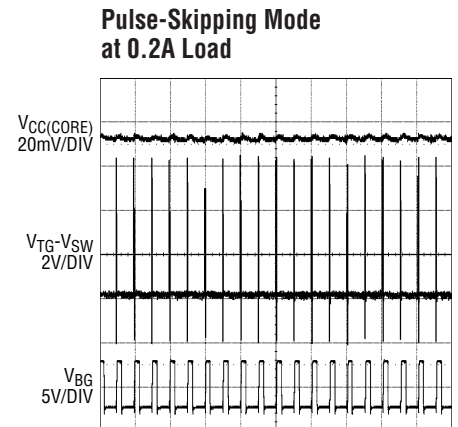

3816 G15

TYPICAL PERFORMANCE CHARACTERISTICS

Start-Up to V_{BOOT}

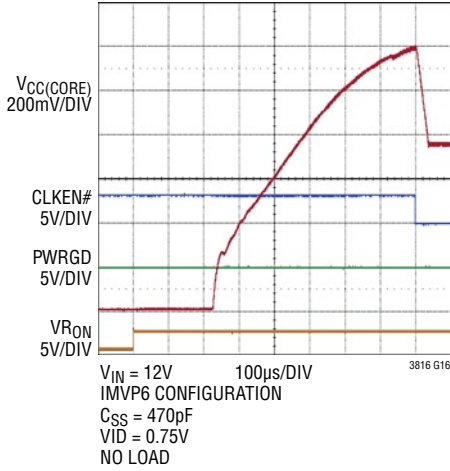

V_{BOOT} to PWRGD Delay

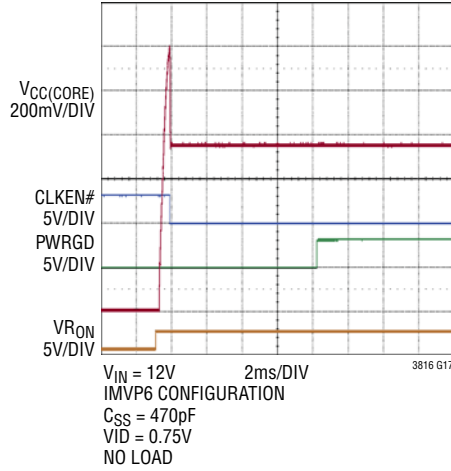

$V_{R_{ON}}$ Shutdown

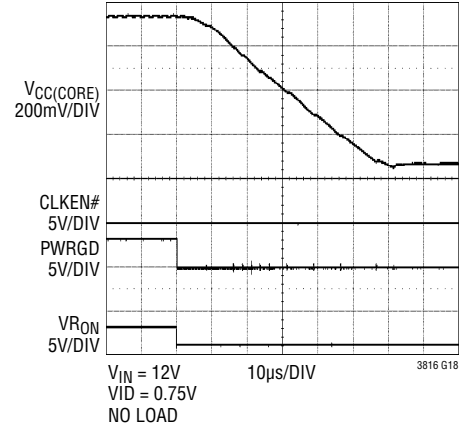

Momentary Overcurrent, 45µs I_{MAX} Pulse

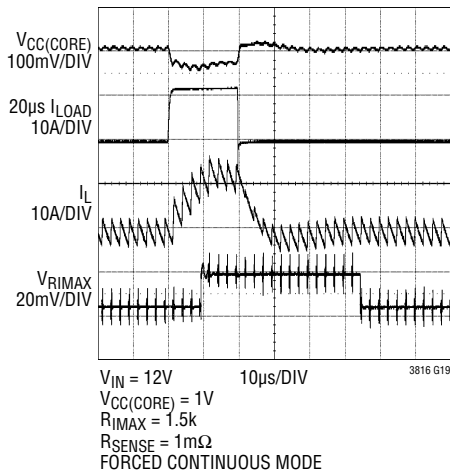

Momentary Overcurrent, 90µs I_{MAX} Pulse

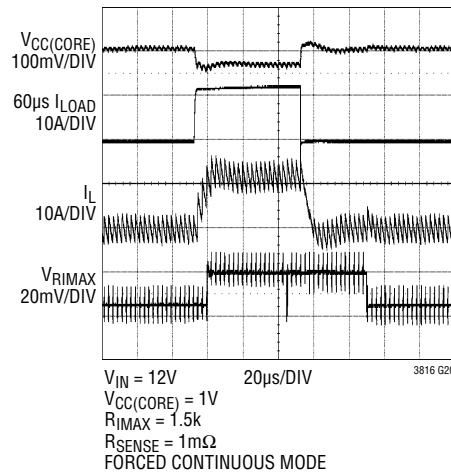

2x Overcurrent

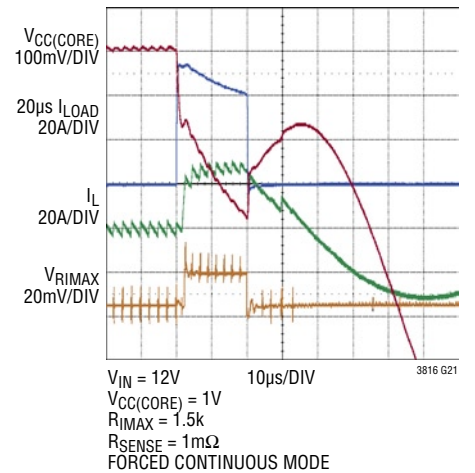

Current Comparator Offset vs Common Mode Range

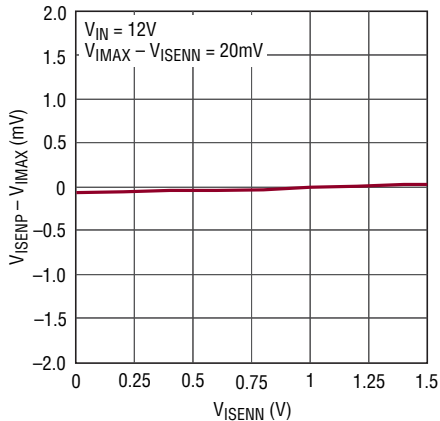

3816 G22

Current Comparator Offset vs Temperature

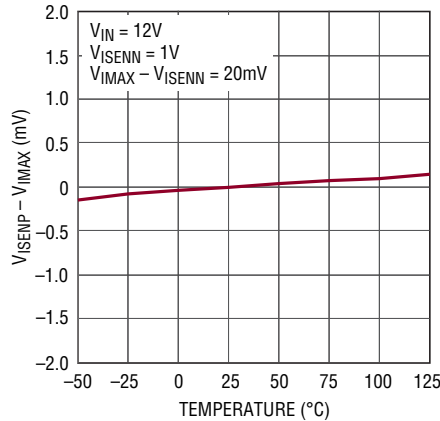

3816 G23

Duty Cycle vs V_{COMP} with Line Feedforward

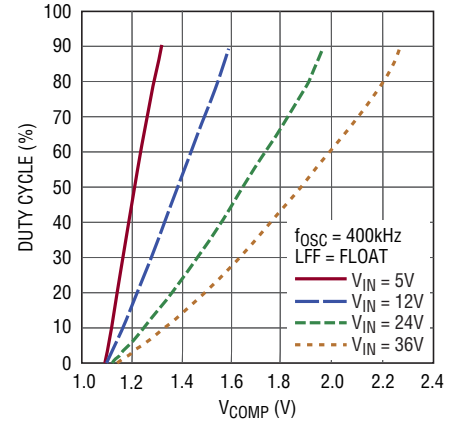

3816 G24

3816f

TYPICAL PERFORMANCE CHARACTERISTICS

Duty Cycle vs V_{COMP} without Line Feedforward

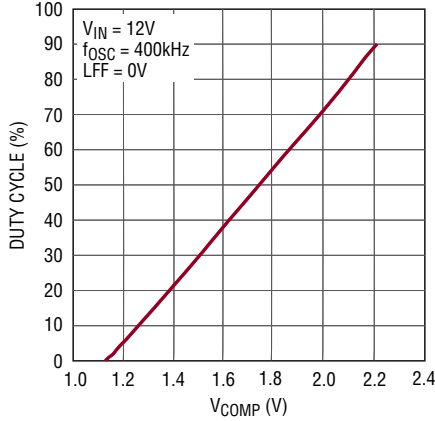

3816 G25

f_{OSC} vs Temperature

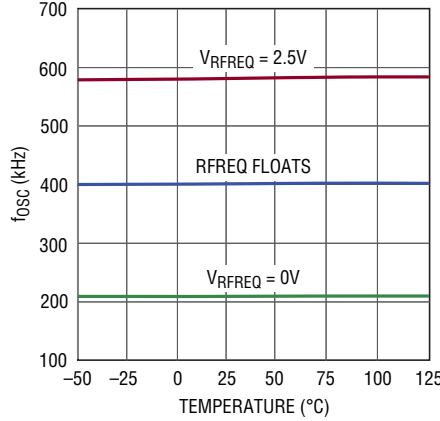

3816 G26

V_{RPTC} vs Temperature

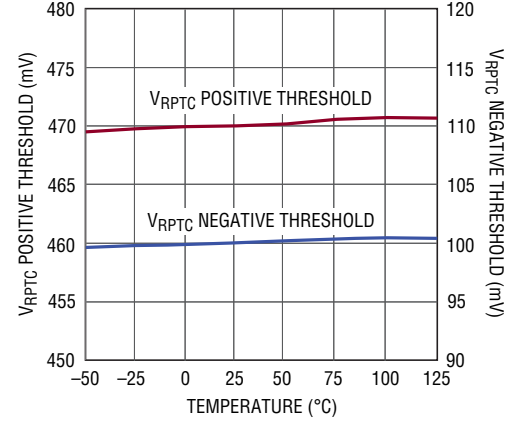

3816 G27

I_{RFREQ} , I_{RPTC} and I_{RPTC} vs Temperature

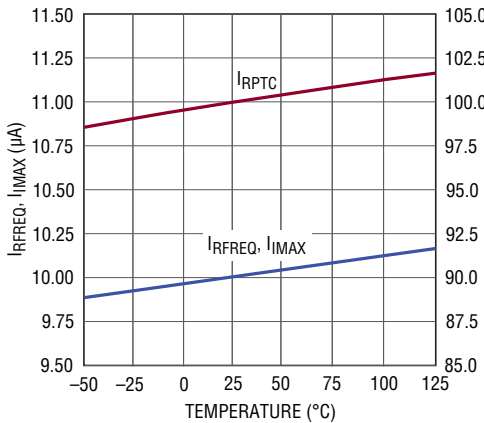

3816 G28

V_{RON} vs Temperature

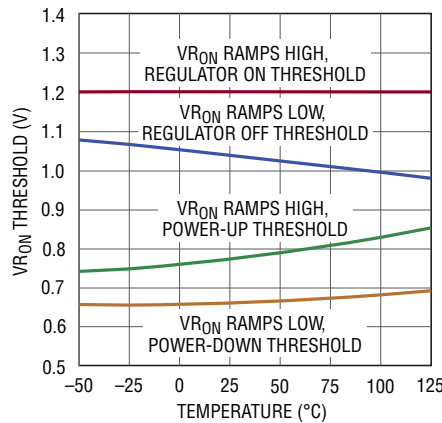

3816 G29

$INTV_{CC}$ UVLO vs Temperature

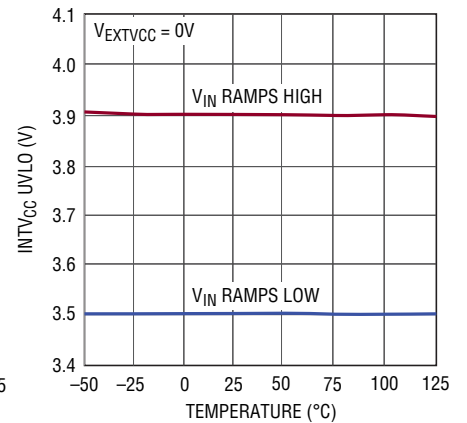

3816 G30

$INTV_{CC}$ Line Regulation

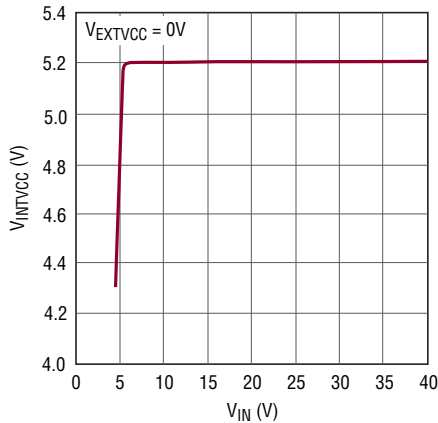

3816 G31

$INTV_{CC}$ Load Regulation

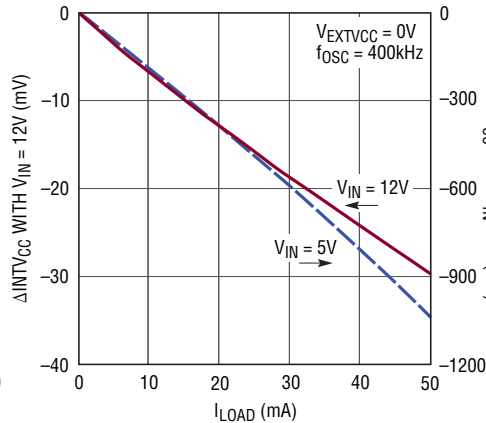

3816 G32

$INTV_{CC}$ Dropout vs Temperature

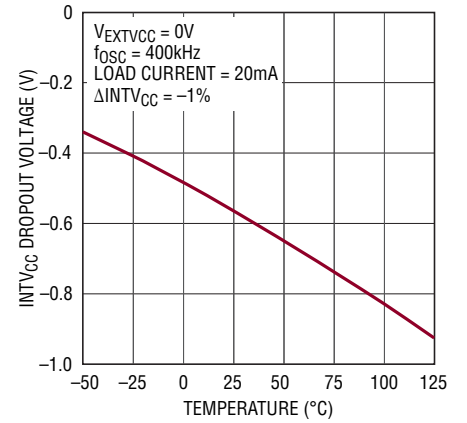

3816 G33

TYPICAL PERFORMANCE CHARACTERISTICS

EXTV_{CC} Switchover Voltage vs Temperature

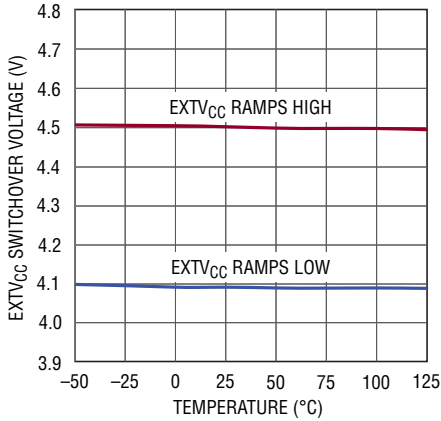

3816 G34

EXTV_{CC} Voltage Drop vs Temperature

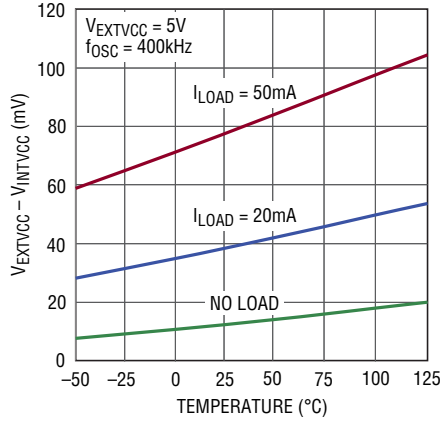

3816 G35

I_{VIN}

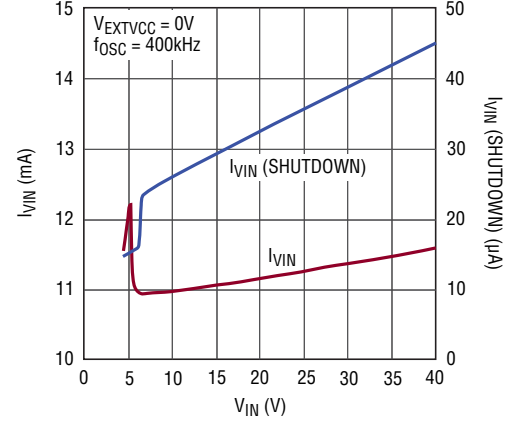

3816 G36

I_{VIN} (Shutdown) vs Temperature

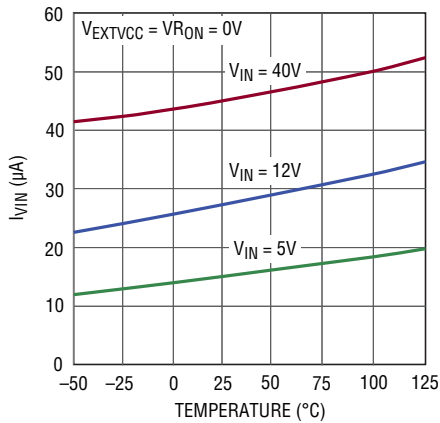

3816 G37

I_{VIN} and I_{EXTVCC} vs Temperature

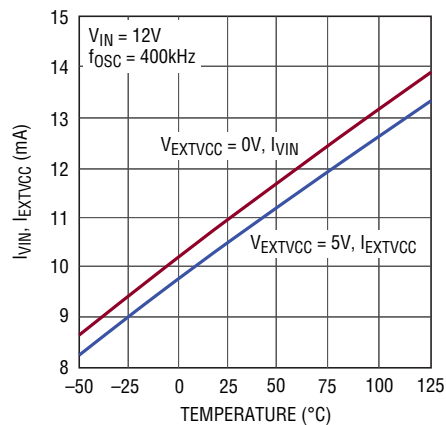

3816 G38

V_{CC(SEN)} and I_{SEN} Input Current vs Common Mode Range

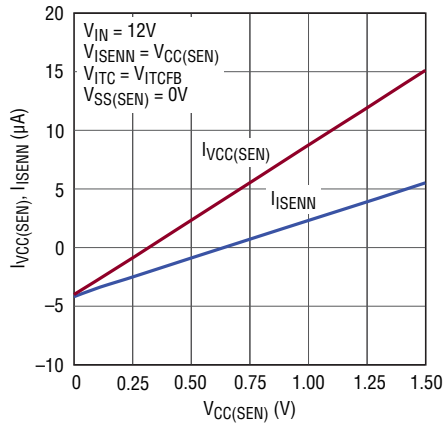

3816 G39

V_{SS(SEN)} Input Current

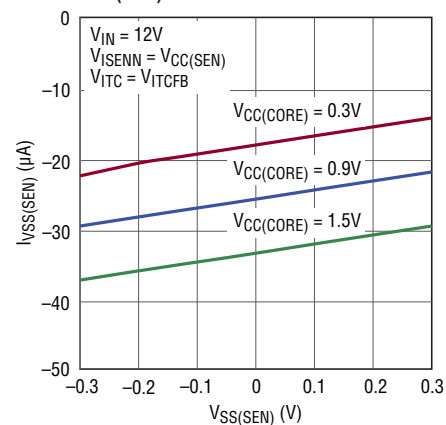

3816 G40

PIN FUNCTIONS (eTSSOP/QFN)

I_{SENN} (Pin 1/Pin 36): Current Sense Negative Input. Connect this pin to the negative terminal of the current sense resistor or the negative terminal of the inductor DCR lowpass filter.

I_{TCFB} (Pin 2/Pin 37): Inductor DCR Temperature Compensation Amplifier Feedback Input. To derive the temperature compensated voltage dropped across the inductor DCR, connect a resistor from the SW node to this pin. An NTC network, in parallel with a capacitor, forms the feedback path of this amplifier. For applications that use a discrete resistor for current sensing, replace the NTC network with a resistor.

I_{TC} (Pin 3/Pin 38): Inductor DCR Temperature Compensation Amplifier Output. The I_{MON} circuitry and the error amplifier obtain the temperature compensated DCR voltage through this amplifier.

PRE_{I_{MON}} (Pin 4/Pin 1): I_{MON} Current Output Setting. PRE_{I_{MON}} is servoed to the I_{SENN} potential. A resistor from PRE_{I_{MON}} to I_{TC} sets the I_{MON} output current. For the IMVP-6 configuration, connect this pin to INTV_{CC}.

I_{MON} (Pin 5/Pin 2): IMVP-6/IMVP-6.5 Configuration Selection and Output Current Monitor. Connect this pin to INTV_{CC} to select the IMVP-6 configuration. At start-up, the switcher V_{OUT} is ramped to 1.2V (V_{BOOT}). In deeper sleep mode, the controller enables the slow V_{OUT} slew rate. Connect a resistor to V_{SS(SEN)} to select the IMVP-6.5 configuration. In this case, V_{BOOT} equals 1.1V, slow slew rate is disabled and the I_{MON} current source is proportional to the load. In the IMVP-6.5 configuration, this pin is internally clamped to 1.1V with respect to the V_{SS(SEN)} pin.

RPTC (Pin 6/Pin 3): Nonlinear PTC Thermistor Input. Connect to a nonlinear PTC thermistor for MOSFET or inductor temperature sensing. This pin is pulled up by a 100 μ A current source. If the potential at RPTC is higher than 0.47V, thermal flag VRTT# is pulled low. RPTC is sensitive to noise pickup. Avoid coupling high frequency switching signals to this pin. If required, bypass this pin with a capacitor to GND.

VR_{ON} (Pin 7/Pin 4): Voltage Regulator Enable Input. The VR_{ON} pin power-up threshold is 1.2V. When forced below 0.65V, a power-down sequence is initiated where the V_{CC(CORE)} output is ramped down near 0V before the IC is put into a low current shutdown mode. The VR_{ON} pin has an internal 1 μ A pull-up current.

V_{SS(SEN)} (Pin 8/Pin 5): Processor V_{CC(CORE)} Negative Terminal Voltage Sense. Negative input of the differential sense amplifier. Connect to the processor V_{SS(SEN)} pin.

V_{CC(SEN)} (Pin 9/Pin 6): Processor V_{CC(CORE)} Positive Terminal Voltage Sense. Positive input of the differential sense amplifier. Connect to the processor V_{CC(SEN)} pin.

SERVO (Pin 10/Pin 7): Error Amplifier AC Input. The controller servos the switcher output voltage to the VID DAC voltage through the error amplifier.

V_{FB} (Pin 11/Pin 8): Error Amplifier Negative Input Pin. V_{FB} is servoed to 1.3V.

COMP (Pin 12/Pin 9): Error Amplifier Output. The COMP pin is connected directly to the error amplifier output and the input of the line feedforward circuit. Use an RC network between the COMP pin and the V_{FB} pin to compensate the feedback loop for stability and optimum transient response.

SS (Pin 13/Pin 10): Soft-Start Input. The SS pin has an internal 1 μ A current source pull-up. A capacitor connected to this pin controls the output voltage start-up. SS is forced low if VR_{ON} or PWRGD is low, or if an overvoltage or overcurrent fault occurs. If the potential at SS is less than 0.3V, the I_{MAX} sourcing current is reduced to 2.5 μ A and the current limit threshold is reduced to 25% of its nominal value.

DPRSLPVR (Pin 14/Pin 11): Deeper Sleep Mode. For the IMVP-6 configuration, 25 μ s after DPRSLPVR is asserted high, the controller enables the V_{OUT} slow slew rate transition. To disable slow slew rate mode, force DPRSLPVR low. Upon power-up, the DPRSLPVR input is ignored until PWRGD is asserted.

PIN FUNCTIONS (eTSSOP/QFN)

CSLEW (Pin 15/Pin 12): VID DAC Slew Rate Control. CSLEW is internally pulled up by a current source. Add a capacitor to program the VID DAC transition slew rate. If slow slew rate is selected, a 100pF capacitor connected to CSLEW results in a VID DAC slew rate of 1.25mV/μs. When slow slew rate is disabled, a 100pF capacitor results in a VID DAC slew rate of 5mV/μs. Avoid coupling high frequency switching signals to this pin. For the IMVP-6.5 configuration, the slow slew rate function is disabled.

VID0-VID6 (Pins 16-22/Pins 13-19): VID DAC Voltage Control Logic Inputs. See Table 1.

RFREQ (Pin 23/Pin 20): Frequency Setting. The voltage on the RFREQ pin determines the free-running operating frequency. The RFREQ pin has an internal 10μA current source pull-up allowing the switching frequency to be programmed by a single external resistor to GND. Alternatively, this pin can be driven with a DC voltage source to control the frequency of the internal oscillator. Floating this pin or shorting this pin to INTV_{CC} allows the controller to run at a fixed 400kHz frequency.

MODE/SYNC (Pin 24/Pin 21): Mode Select/Synchronization Input. This pin is pulled up by an internal 1μA current source. Floating this pin or shorting it to INTV_{CC} enables pulse-skipping mode. Shorting this pin to ground configures forced continuous mode. During frequency synchronization, the phase-locked loop forces the controller to operate in continuous mode with the falling top gate signal synchronized to the falling edge of the MODE/SYNC input pulse. During start-up, the controller is forced to run in pulse-skipping mode.

BSOURCE (Pin 25/Pin 22): Bottom MOSFET Source. Connect this pin to the source of the bottom power MOSFET. Do not short BSOURCE to the LTC3816 exposed pad directly.

BG (Pin 26/Pin 23): Bottom Gate Drive. The BG pin drives the gate of the bottom N-channel synchronous switch MOSFET.

INTV_{CC} (Pin 27/Pin 24): Output of the Internal Linear Low Dropout Regulator. The driver and control circuits are powered from this voltage source. The INTV_{CC} pin must be decoupled to GND with a minimum 4.7μF low ESR ceramic capacitor (X5R or better).

EXTV_{CC} (Pin 28/Pin 25): External Power Input to an Internal Switch Connected to INTV_{CC}. This switch closes and supplies the IC power, bypassing the internal low dropout regulator, whenever EXTV_{CC} is higher than 4.5V. Do not exceed 6V on this pin.

V_{IN} (Pin 29/Pin 26): Main Supply Pin. A bypass capacitor should be connected from this pin to the GND pin.

BOOST (Pin 30/Pin 27): Top Gate Driver Supply. The BOOST pin should be decoupled to the SW node with a 0.1μF low ESR (X5R or better) ceramic capacitor. An external Schottky diode from INTV_{CC} to BOOST creates a complete floating charge-pumped supply from BOOST to SW.

TG (Pin 31/Pin 28): Top Gate Drive. The TG pin drives the top N-channel MOSFET with a voltage swing equal to INTV_{CC} superimposed on the switch node voltage.

PIN FUNCTIONS (eTSSOP/QFN)

SW (Pin 32/Pin 29): Switching Node. Connect SW to the source of the upper power MOSFET and to the negative terminal of the BOOST pin decoupling capacitor.

PWRGD (Pin 33/Pin 30): Open-Drain Power Good Output/Power Bad Latchoff Input. PWRGD is an open-drain output pin and can be connected to other open-drain outputs to implement wire-ORing. PWRGD is externally pulled high 10ms after the output regulates. After start-up, if a fault condition causes PWRGD to go low, or PWRGD is externally pulled low, the regulator output voltage is actively ramped to 0V and PWRGD remains latched low until either the power is cycled or $V_{R_{ON}}$ toggles. PWRGD has a 750 μ s de-glitch delay and is masked for 100 μ s after the VID code changes. In deeper sleep mode, the PWRGD comparators are disabled and not allowed to de-assert the PWRGD pin.

CLKEN# (Pin 34/Pin 31): Open-Drain Clock Enable Indicator. 75 μ s after $V_{CC(CORE)}$ reaches the V_{BOOT} voltage, CLKEN# pulls low to enable the processor phase-locked loop.

VRTT# (Pin 35/Pin 32): Open-Drain Output for Voltage Regulator Thermal Throttling. The VRTT# pin pulls low if the RPTC voltage exceeds 0.47V or if the control IC junction temperature exceeds 150°C.

LFF (Pin 36/Pin 33): Line Feedforward. This pin has a 1 μ A pull-up current source to $INTV_{CC}$. Floating this pin or connecting it to $INTV_{CC}$ enables the line feedforward compensation. Connect this pin to GND to disable the line feedforward compensation.

ISENP (Pin 37/Pin 34): Current Sense Positive Input. Connect this pin to the positive terminal of the current sense resistor or to the output of the inductor DCR lowpass filter.

I_{MAX} (Pin 38/Pin 35): Current Comparator Threshold Setting. The I_{MAX} pin has an internal 10 μ A pull-up current source, allowing the current limit comparator threshold to be programmed by a single external resistor. The controller allows a momentary 45 μ s overcurrent event to occur within a period of 630 μ s. See Current Sense and Current Limit in Applications Information.

GND (Exposed Pad Pin 39/Exposed Pad Pin 39): Ground. The soft-start and slew rate control capacitors as well as the frequency setting and thermal shutdown resistors should return to this exposed pad ground pin. This GND pin should also be connected to the negative terminals of the local voltage regulator output capacitors through vias to the PCB ground plane.

FUNCTIONAL DIAGRAM

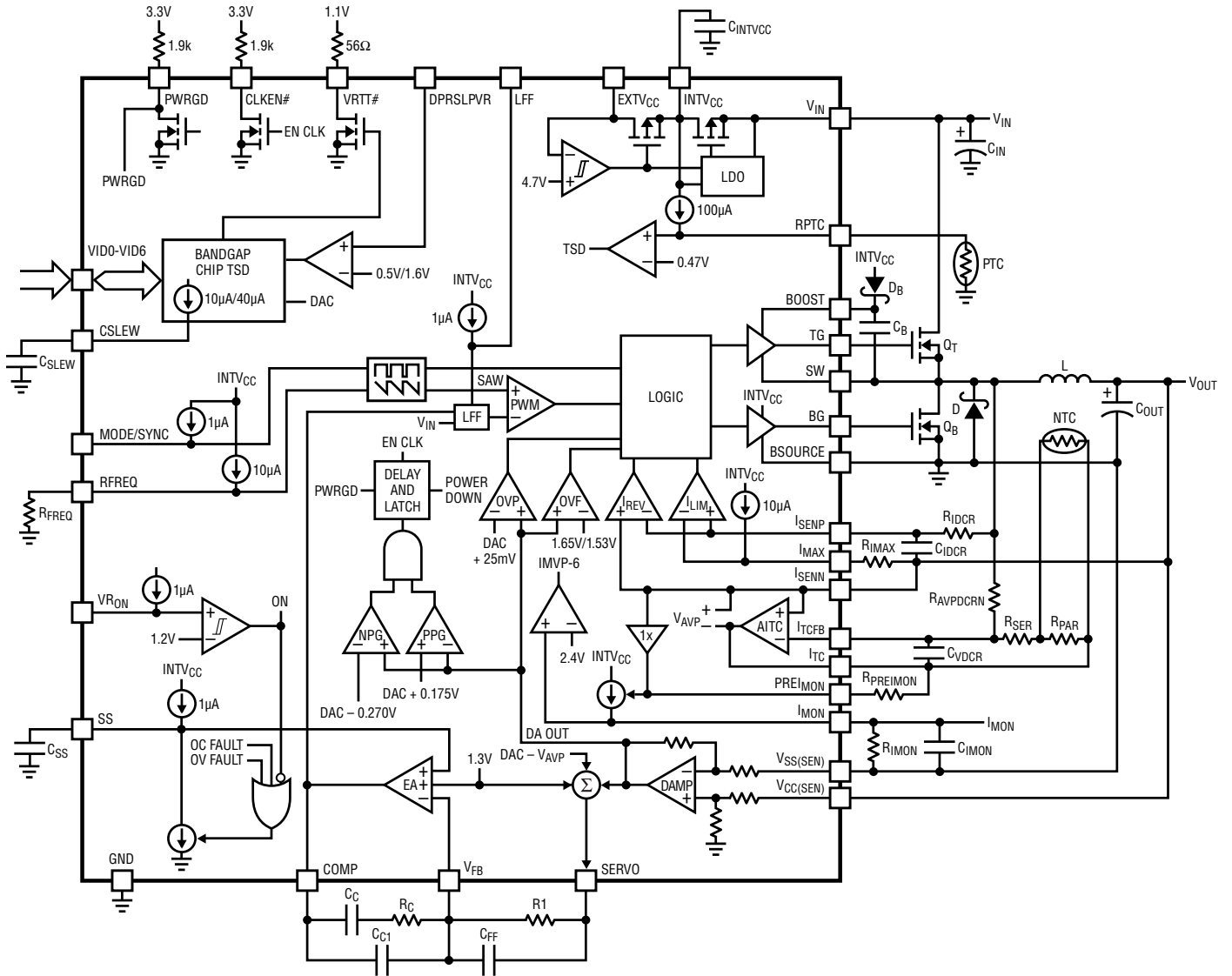

Figure 1. Functional Diagram

OPERATION (Refer to Funtional Diagram)

Table 1. IMVP-6/IMVP-6.5 VID Output Voltage Programming

VID6	VID5	VID4	VID3	VID2	VID1	VID0	V _{CC(CORE)}
0	0	0	0	0	0	0	1.5000
0	0	0	0	0	0	1	1.4875
0	0	0	0	0	1	0	1.4750
0	0	0	0	0	1	1	1.4625
0	0	0	0	1	0	0	1.4500
0	0	0	0	1	0	1	1.4375
0	0	0	0	1	1	0	1.4250
0	0	0	0	1	1	1	1.4125
0	0	0	1	0	0	0	1.4000
0	0	0	1	0	0	1	1.3875
0	0	0	1	0	1	0	1.3750
0	0	0	1	0	1	1	1.3625
0	0	0	1	1	0	0	1.3500
0	0	0	1	1	0	1	1.3375
0	0	0	1	1	1	0	1.3250
0	0	0	1	1	1	1	1.3125
0	0	1	0	0	0	0	1.3000
0	0	1	0	0	0	1	1.2875
0	0	1	0	0	1	0	1.2750
0	0	1	0	0	1	1	1.2625
0	0	1	0	1	0	0	1.2500
0	0	1	0	1	0	1	1.2375
0	0	1	0	1	1	0	1.2250
0	0	1	0	1	1	1	1.2125
0	0	1	1	0	0	0	1.2000
0	0	1	1	0	0	1	1.1875
0	0	1	1	0	1	0	1.1750
0	0	1	1	0	1	1	1.1625
0	0	1	1	1	0	0	1.1500
0	0	1	1	1	0	1	1.1375
0	0	1	1	1	1	0	1.1250
0	0	1	1	1	1	1	1.1125
0	1	0	0	0	0	0	1.1000
0	1	0	0	0	0	1	1.0875
0	1	0	0	0	1	0	1.0750
0	1	0	0	0	1	1	1.0625
0	1	0	0	1	0	0	1.0500
0	1	0	0	1	0	1	1.0375
0	1	0	0	1	1	0	1.0250
0	1	0	0	1	1	1	1.0125
0	1	0	1	0	0	0	1.0000
0	1	0	1	0	0	1	0.9875
0	1	0	1	0	1	0	0.9750
0	1	0	1	0	1	1	0.9625
0	1	0	1	1	0	0	0.9500
0	1	0	1	1	0	1	0.9375
0	1	0	1	1	1	0	0.9250
0	1	0	1	1	1	1	0.9125
0	1	1	0	0	0	0	0.9000
0	1	1	0	0	0	1	0.8875
0	1	1	0	0	1	0	0.8750
0	1	1	0	0	1	1	0.8625
0	1	1	0	1	0	0	0.8500
0	1	1	0	1	0	1	0.8375
0	1	1	0	1	1	0	0.8250
0	1	1	0	1	1	1	0.8125
0	1	1	1	0	0	0	0.8000
0	1	1	1	0	0	1	0.7875
0	1	1	1	0	1	0	0.7750
0	1	1	1	0	1	1	0.7625
0	1	1	1	1	0	0	0.7500
0	1	1	1	1	0	1	0.7375
0	1	1	1	1	1	0	0.7250
0	1	1	1	1	1	1	0.7125

VID6	VID5	VID4	VID3	VID2	VID1	VID0	V _{CC(CORE)}
1	0	0	0	0	0	0	0.7000
1	0	0	0	0	0	1	0.6875
1	0	0	0	0	1	0	0.6750
1	0	0	0	0	1	1	0.6625
1	0	0	0	1	0	0	0.6500
1	0	0	0	1	0	1	0.6375
1	0	0	0	1	1	0	0.6250
1	0	0	0	1	1	1	0.6125
1	0	0	1	0	0	0	0.6000
1	0	0	1	0	0	1	0.5875
1	0	0	1	0	1	0	0.5750
1	0	0	1	0	1	1	0.5625
1	0	0	1	1	0	0	0.5500
1	0	0	1	1	0	1	0.5375
1	0	0	1	1	1	0	0.5250
1	0	0	1	1	1	1	0.5125
1	0	1	0	0	0	0	0.5000
1	0	1	0	0	0	1	0.4875
1	0	1	0	0	1	0	0.4750
1	0	1	0	0	1	1	0.4625
1	0	1	0	1	0	0	0.4500
1	0	1	0	1	0	1	0.4375
1	0	1	0	1	1	0	0.4250
1	0	1	0	1	1	1	0.4125
1	0	1	1	0	0	0	0.4000
1	0	1	1	0	0	1	0.3875
1	0	1	1	0	1	0	0.3750
1	0	1	1	0	1	1	0.3625
1	0	1	1	1	0	0	0.3500
1	0	1	1	1	0	1	0.3375
1	0	1	1	1	1	0	0.3250
1	0	1	1	1	1	1	0.3125
1	1	0	0	0	0	0	0.3000
1	1	0	0	0	0	1	0.2875
1	1	0	0	0	1	0	0.2750
1	1	0	0	0	1	1	0.2625
1	1	0	0	1	0	0	0.2500
1	1	0	0	1	0	1	0.2375
1	1	0	0	1	1	0	0.2250
1	1	0	0	1	1	1	0.2125
1	1	0	1	0	0	0	0.2000
1	1	0	1	0	0	1	0.1875
1	1	0	1	0	1	0	0.1750
1	1	0	1	0	1	1	0.1625
1	1	0	1	1	0	0	0.1500
1	1	0	1	1	0	1	0.1375
1	1	0	1	1	1	0	0.1250
1	1	0	1	1	1	1	0.1125
1	1	1	0	0	0	0	0.1000
1	1	1	0	0	0	1	0.0875
1	1	1	0	0	1	0	0.0750
1	1	1	0	0	1	1	0.0625
1	1	1	0	1	0	0	0.0500
1	1	1	0	1	0	1	0.0375
1	1	1	0	1	1	0	0.0250
1	1	1	0	1	1	1	0.0125
1	1	1	1	0	0	0	0.0000
1	1	1	1	0	0	1	0.0000
1	1	1	1	0	1	0	0.0000
1	1	1	1	0	1	1	0.0000
1	1	1	1	1	0	0	0.0000
1	1	1	1	1	0	1	0.0000
1	1	1	1	1	1	0	0.0000
1	1	1	1	1	1	1	0.0000

3816f

OPERATION (Refer to Functional Diagram)

The LTC3816 is a constant frequency, voltage mode DC/DC step-down controller that complies with the Intel IMVP-6/IMVP-6.5 specifications. The 7-bit VID code programs the switcher output voltage as specified in Table 1. Figure 2 shows the timing diagram. Upon start-up, the switcher output soft-start ramps to the V_{BOOT} voltage. 75 μ s after reaching the V_{BOOT} power good threshold, which is about 45mV below V_{BOOT} , the controller forces the CLKEN# pin low and the VID code is loaded. Next, the output is servoed to its VID DAC potential. 10ms after regulation, PWRGD pulls high to indicate that the switcher is regulating and has completed its start-up phase.

The LTC3816 uses two external synchronous N-channel MOSFETs. A floating topside driver and a simple external charge pump provide full gate drive to the upper MOSFET. The controller uses a leading edge modulation architecture to allow extremely low duty cycles and fast load step response. In a typical LTC3816 switching cycle, the PWM comparator turns on the top MOSFET to charge the output capacitor. An internal clock resets the top MOSFET and turns on the bottom MOSFET to reduce the output charging current. This switching cycle repeats itself at an internally fixed frequency, or in synchronization with an external oscillator.

The top gate duty cycle is controlled by the voltage feedback loop which includes an internal differential amplifier that senses the differential output voltage between the

$V_{CC(SEN)}$ and $V_{SS(SEN)}$ pins. The AITC amplifier monitors the inductor current and computes the load dependent output droop required to implement the active voltage positioning features in IMVP-6/IMVP-6.5. The IC servos the differential output voltage to the VID DAC voltage minus the small load dependent AVP droop.

The LTC3816 feedback loop is capable of dynamically changing the regulator output to different VID DAC voltages. Upon receiving a new VID code, the LTC3816 regulates to its new potential with a programmable slew rate which is selected to prevent the converter from generating audible noise. The switcher output load current can be monitored by measuring the I_{MON} pin potential. The LTC3816 forces the I_{MON} pin voltage to be proportional to the average load current with a gain configured by the $R_{PREIMON}$ and R_{IMON} resistors.

The LTC3816 includes an onboard current limit circuit that senses the inductor current through an external sense resistor or the inductor DCR. The peak inductor current can be controlled by selecting the current limit R_{IMAX} resistance. The LTC3816 current limit architecture allows momentary overcurrent events for a predefined duration (see the Current Sense and Current Limit sections). Upon current limit, the top gate is shut off, the SS external capacitor is discharged to limit the top gate duty cycle, and the switcher output voltage is reduced until the load fault is removed.

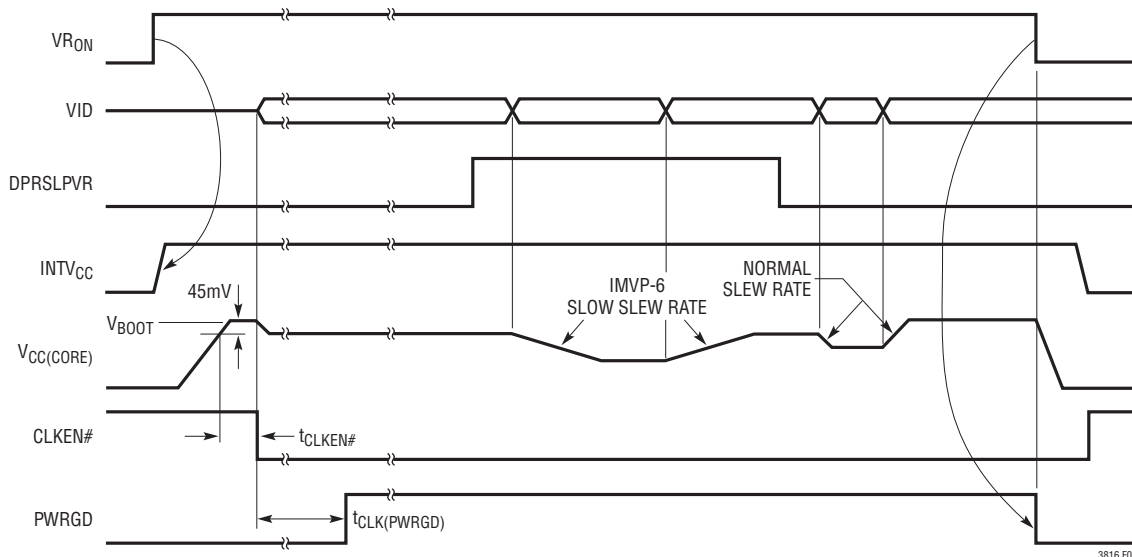

Figure 2. LTC3816 Power-Up and Power-Down Timing Diagram

3816 F02

APPLICATIONS INFORMATION

LDO, INTV_{CC}/EXTV_{CC} POWER SUPPLY

The LTC3816 is designed to operate with a wide range of V_{IN} input voltages. The IC includes a 5.2V LDO to power the driver and control circuits. The LDO output, INTV_{CC} should be bypassed with a minimum 4.7 μ F low ESR ceramic capacitor. The INTV_{CC} regulator can supply up to 50mA of total LTC3816 quiescent current, $I_{Q(TOT)}$, which consists of the static supply current, I_Q , and the current required to charge the gate capacitance, $Q_{G(TOT)}$, of the top and bottom power MOSFETs.

$$I_{Q(TOT)} = I_Q + Q_{G(TOT)} \cdot f_{OSC}$$

$$P_{DISS} = V_{IN} \cdot (I_Q + Q_{G(TOT)} \cdot f_{OSC})$$

$$T_J = T_A + P_{DISS} \cdot \theta_{JA}$$

The value of $Q_{G(TOT)}$ can be obtained from the MOSFET data sheets. For high V_{IN} and high frequency operation, care must be taken to ensure that the maximum junction temperature T_{JMAX} of the IC is never exceeded.

When the EXTV_{CC} pin is left open or tied to a voltage less than 4.5V, the 5.2V LDO powers INTV_{CC}. If EXTV_{CC} is taken above 4.5V, the LDO is turned off and an internal switch connects INTV_{CC} to EXTV_{CC}. Do not apply greater than 6V to the EXTV_{CC} pin, and ensure that $EXTV_{CC} < V_{IN} + 0.3V$ unless EXTV_{CC} is shorted to the V_{IN} supply. Using the EXTV_{CC} pin allows INTV_{CC} to be powered from an external source reducing LDO losses and improving the regulator efficiency, especially at high V_{IN} . When the EXTV_{CC} pin is used, the chip power dissipation reduces to:

$$P_{DISS} = V_{EXTV_{CC}} \cdot (I_Q + Q_{G(TOT)} \cdot f_{OSC})$$

If the V_{IN} supply is low enough for the INTV_{CC} LDO to enter dropout, the output voltage of the LDO becomes:

$$V_{INTV_{CC}(DROPOUT)} = V_{IN} - V_{DROPOUT}$$

The LDO dropout voltage is a function of the total quiescent current $I_{Q(TOT)}$, V_{IN} voltage and junction temperature. The temperature coefficient of the LDO dropout voltage is approximately 6400ppm/ $^{\circ}$ C. To enable proper operation, make sure that the LDO output voltage meets the INTV_{CC} undervoltage and minimum MOSFET gate driver requirements. If V_{IN} is connected to a fixed 5V supply, it is

advisable to short EXTV_{CC} to V_{IN} . In this case, the INTV_{CC} output voltage becomes:

$$V_{INTV_{CC}(EXTV_{CC})} = V_{EXTV_{CC}} - I_{Q(TOT)} \cdot R_{EXTV_{CC}}$$

where $R_{EXTV_{CC}}$ is the internal EXTV_{CC} switch on-resistance. It has a typical value of 2 Ω at 25 $^{\circ}$ C and has a temperature coefficient of approximately 4000ppm/ $^{\circ}$ C.

UNDERVOLTAGE LOCKOUT AND SHUTDOWN

A precision undervoltage lockout (UVLO) comparator monitors the INTV_{CC} voltage and enables soft-start operation once INTV_{CC} is above 3.9V. For power supplies that start-up slowly, the gate drivers could begin switching when V_{IN} is well below its steady-state value. The high inrush current through the input power cable could cause the V_{IN} supply to dip below the UVLO threshold and result in hiccup operation at start-up. This problem can be easily overcome by adding a V_{IN} UVLO function as shown in Figure 3. Connect an external resistive divider from V_{IN} to VR_{ON}. Set the resistive divider according to the following equation:

$$V_{UVLO} = 1.2V = V_{IN(UVLO)} \frac{R_{ON1}}{R_{ON1} + R_{ON2}}$$

where $V_{IN(UVLO)}$ is the desired V_{IN} UVLO threshold. The resistances are normally chosen so that the error caused by the internal 1 μ A pull-up current has a negligible effect on the UVLO threshold. Be careful not to allow the resistive divider output voltage to exceed the 6V maximum rating of the VR_{ON} pin.

If the external resistive divider is not used, upon power-up, the VR_{ON} pin is pulled up by an internal 1 μ A pull-up current. The LTC3816 can be put into a low power shut-

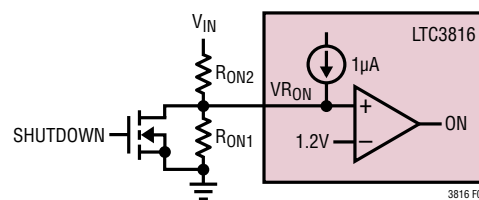

Figure 3. V_{IN} UVLO Circuit

APPLICATIONS INFORMATION

down mode by pulling the VR_{ON} pin below 0.65V. In the shutdown mode, the internal circuitry and the $INTV_{CC}$ regulator are off and the supply current drops well below 100 μ A. When the VR_{ON} pin voltage is between 0.65V and 1.2V, the $INTV_{CC}$ regulator and internal circuitry power up but the driver outputs remain low.

TOPSIDE MOSFET DRIVER SUPPLY

An external bootstrap capacitor, C_B , connected from the BOOST pin to the SW pin supplies the topside gate driver as shown in Figure 1. Capacitor C_B is charged through the external diode, D_B , from $INTV_{CC}$ when the SW pin is low. When the topside MOSFET is turned on, the top driver places the C_B voltage across the gate source of the top MOSFET. This enhances the MOSFET and turns on the top switch. The switch node voltage, SW, rises to V_{IN} and the BOOST pin follows. With the topside MOSFET on, the boost voltage is above the input supply:

$$V_{BOOST} = V_{IN} + V_{INTVCC}$$

The value of the boost capacitor, C_B , needs to be at least 100 times that of the total input capacitance of the topside MOSFET. The reverse breakdown of the external Schottky diode, D_B , must be greater than $V_{IN(MAX)}$.

IMVP-6/IMVP-6.5 SELECTION AND V_{BOOT} VOLTAGE

The LTC3816 can be configured to meet either IMVP-6 or IMVP-6.5 requirements. To select IMVP-6 operation, short both I_{MON} and $PREI_{MON}$ to $INTV_{CC}$. At start-up, when VR_{ON} is asserted, the switcher output ramps to $V_{BOOT} = 1.2V$ regardless of the VID code. To configure IMVP-6.5 operation, connect a resistor from I_{MON} to $V_{SS(SEN)}$ and another resistor from $PREI_{MON}$ to I_{TC} . The I_{MON} and $PREI_{MON}$ resistance set the I_{MON} gain (see the I_{MON} section). The V_{BOOT} voltage for IMVP-6.5 is 1.1V.

SOFT-START OPERATION

The start-up of V_{OUT} is controlled by the LTC3816's SS pin. When the voltage at the SS pin is less than 1.3V, the LTC3816 regulates the V_{FB} voltage to the SS pin voltage instead of 1.3V. This allows the user to program the soft-start of the regulator output with a capacitor from the SS

pin to GND. An internal 1 μ A current source charges this capacitor, creating a voltage ramp on the SS pin. As the SS pin voltage rises from 0V to 1.3V, the output voltage, V_{OUT} , rises smoothly from 0V to its V_{BOOT} value. Once the soft-start interval is over, the internal current source continues charging the SS capacitor until the SS potential is internally clamped at about 2.7V. For the IMVP-6 configuration, a 1000pF SS capacitor generates roughly a 1.6ms start-up time. With the IMVP-6.5 configuration, the start-up time is about 1.5ms.

During severe overload conditions, the LTC3816 discharges the SS capacitor to lower the switcher output voltage. If the potential at SS is forced below 0.3V, the controller reduces its I_{MAX} sourcing current from 10 μ A to 2.5 μ A and cuts the short-circuit current to about 25% of its nominal value.

CURRENT SENSE AND CURRENT LIMIT

The LTC3816 features an onboard cycle-by-cycle user-programmable current limit circuit that controls the peak inductor current. The I_{MAX} pin has an internal 10 μ A pull-up current source, allowing the maximum load current $I_{LOAD(MAX)}$ to be programmed by a single external resistor R_{IMAX} connected between the I_{MAX} and I_{SENN} pins.

$$I_{L(PEAK)} = \frac{I_{IMAX} \cdot R_{IMAX}}{R_{SENSE}}$$

$$I_{LOAD(MAX)} < I_{LIMIT} = I_{L(PEAK)} - \frac{\Delta I_L}{2} = \frac{I_{IMAX} \cdot R_{IMAX}}{R_{SENSE}} - \frac{\Delta I_L}{2}$$

where $I_{L(PEAK)}$ is the peak inductor current, I_{IMAX} is the I_{MAX} pin pull-up current, R_{SENSE} is the current sense resistor value and ΔI_L is the inductor ripple current.

$$\Delta I_L = \frac{1}{f_{OSC} \cdot L} V_{OUT} \left(1 - \frac{V_{OUT}}{V_{IN}} \right)$$

Note that the output ripple current varies with the switching frequency, inductor value and duty cycle. Hence, the current limit value should be checked on the application board to ensure that $I_{LOAD(MAX)} < I_{LIMIT}$ under all operating conditions and temperature variations.

For current sensing using a low value sense resistor, the sense resistor parasitic inductance must be considered to

APPLICATIONS INFORMATION

achieve accurate current sensing. Figure 4 shows a real current sensing resistor, R_{SENSE} , which can be modeled with an ideal resistance, R_{SEN} , in series with its parasitic ESL. As shown in Figure 4, the voltage across the sense resistor includes the voltage across the parasitic inductor which is a strong function of inductor ripple current and the switching frequency. This effectively reduces the current limit threshold, typically by more than 30%. The voltage across the sense resistor can be extracted from a lowpass filter placed close to the controller input sense pins as shown in Figure 4. The voltage across the sensing capacitor, C_{ISR} , is:

$$V_{CISR} = I_L \cdot R_{SEN} \left[\frac{1 + \frac{sESL}{R_{SEN}}}{1 + sR_{ISR} \cdot C_{ISR}} \right]$$

In the frequency domain, the second term in the above equation must be equal to 1 to ensure that the voltage across the filter capacitor is independent of operating frequency. To meet this requirement, the value of the RC filter should fulfill the following condition:

$$R_{ISR} \cdot C_{ISR} = \frac{ESL}{R_{SEN}}$$

The ESL value can be obtained from the manufacturer's data sheet or estimated with an oscilloscope, as shown in the Figure 4 waveform, using the following equation:

$$ESL = \frac{V_{ESL(ON)} + |V_{ESL(OFF)}|}{\Delta I_L \left(\frac{1}{t_{ON}} + \frac{1}{t_{OFF}} \right)}$$

where t_{ON} is the TG on time and t_{OFF} is the TG off time.

For high efficiency applications, the inductor DCR provides a method of sensing the inductor current without incurring additional power loss from a sense resistor. The DCR of the inductor represents the small amount of resistance in the copper winding, which can be less than $1m\Omega$ for today's low value, high current inductors. Figure 5 shows a simplified inductor model, which can be modeled with an ideal inductor, L , in series with its parasitic DCR. The DCR value can be obtained from the inductor manufacturer's

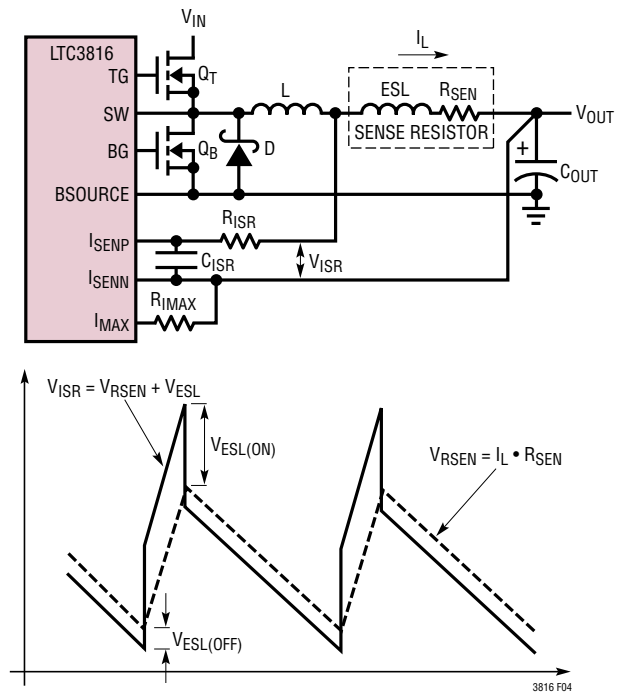

Figure 4. Current Limit Sensing Using a Low Value Sense Resistor

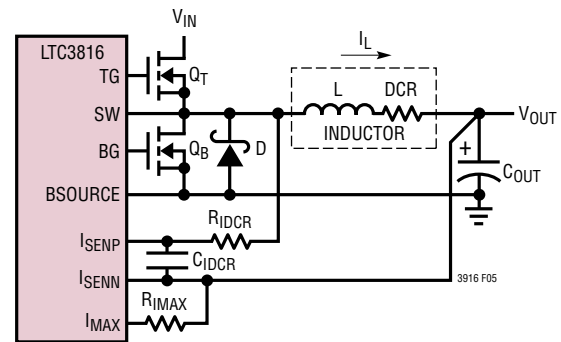

Figure 5. Current Limit Sensing Using Inductor DCR

data sheet. Similar to the sense resistor application circuit, the voltage across the inductor DCR can be extracted from a lowpass filter and the current limit threshold is given by the following equation:

$$I_{L(PEAK)} = \frac{I_{MAX} \cdot R_{IMAX}}{R_{DCR}}$$

$$I_{LOAD(MAX)} < I_{LIMIT} = I_{L(PEAK)} - \frac{\Delta I_L}{2} = \frac{I_{MAX} \cdot R_{IMAX}}{R_{DCR}} - \frac{\Delta I_L}{2}$$

$$\text{if } R_{IDCR} \cdot C_{IDCR} = \frac{L}{R_{DCR}}$$

APPLICATIONS INFORMATION

Note that the value of R_{DCR} must account for its temperature coefficient, which is approximately $0.39\%/^{\circ}\text{C}$.

The current limit architecture of the LTC3816 allows short durations of instantaneous overload. Upon power-up, the current limit threshold is set to $1\times$, equal to I_{LIMIT} . The load is limited to I_{LIMIT} until the switcher output reaches its V_{BOOT} potential. Beyond this point, during the VID DAC slewing interval, the I_{MAX} sourcing current automatically switches from $10\mu\text{A}$ to $20\mu\text{A}$ and the current limit threshold increases to $2\times$ to enable the output capacitor voltage to track the DAC transition. If the controller detects that there is an overload condition when the DAC is not slewing, the current limit threshold increases to $2\times$ for a duration of $45\mu\text{s}$. If the overload interval is shorter than $45\mu\text{s}$, the IC allows another overcurrent event within the next $630\mu\text{s}$, as shown in Figure 6a. However, if an overload occurs within the $630\mu\text{s}$ following the second event, the controller current limits, as shown in Figure 6b.

If the overload condition persists for more than $45\mu\text{s}$, the LTC3816 allows the $2\times$ current limit to continue for

another cycle. After $90\mu\text{s}$, the I_{MAX} current returns to $10\mu\text{A}$, and the output load is limited to $1\times$ for the next $630\mu\text{s}$ as shown in Figure 6c. Figure 6d shows the condition when a repetitive overload event triggers current limit.

Figure 6e shows that at any instant, if the load current is above $1\times$ for more than $90\mu\text{s}$, or higher than $2\times$, the controller enters current limit. Under this condition, the TG duty cycle is reduced and the SS capacitor is discharged

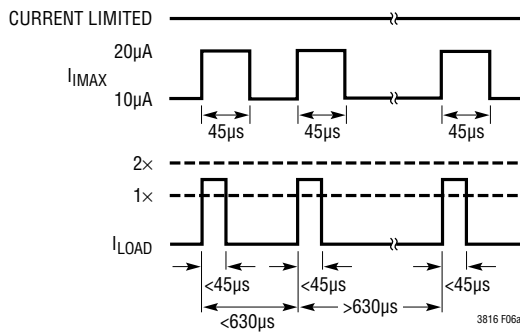

Figure 6a. Permissible Overload

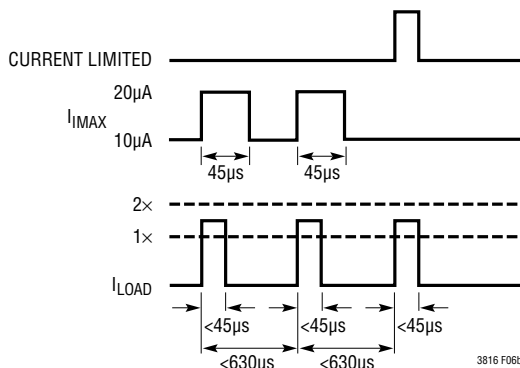

Figure 6b. Repeated Overload Triggers Current Limit

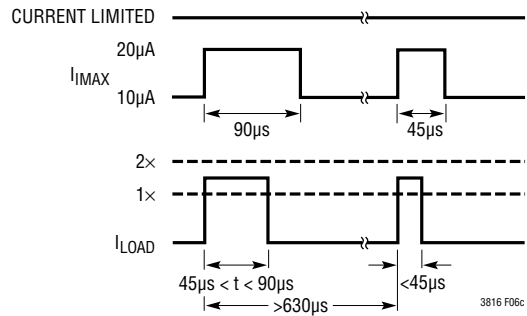

Figure 6c. Allowable Longer Overload Condition

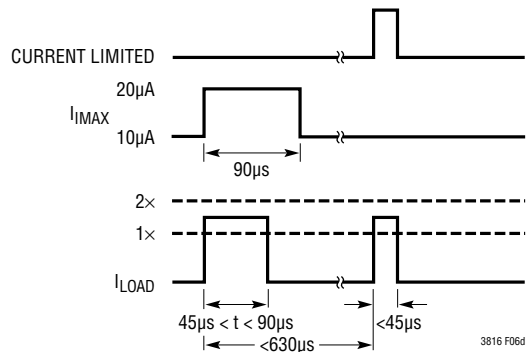

Figure 6d. Allowable Longer Overload Condition, Followed by Repeated Overload Triggers Current Limit

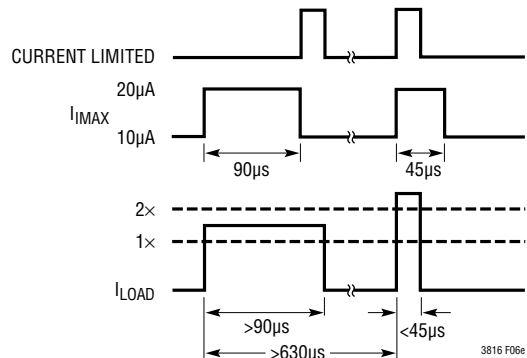

Figure 6e. Long Overload or Excessive Loading Triggers Current Limit Condition

APPLICATIONS INFORMATION

to lower the regulator output voltage. This current limit condition persists until the fault condition disappears or the controller detects a low output voltage fault and forces the switcher output to latch off. Once the output voltage is lower than the power good threshold, the controller limits the maximum load to $1\times$ to reduce the short-circuit current.

ACTIVE VOLTAGE POSITIONING (AVP)

In a conventional buck converter, the feedback control regulates the output voltage to the same level for the entire load range as shown in Figure 7a. The peak-to-peak output voltage spikes resulting from the load step must be smaller than the voltage tolerance window.

To reduce the regulator output voltage peak-to-peak perturbation resulting from a load transient, the LTC3816 modulates the output voltage based on the output loading current. The built-in AVP circuit lowers the output voltage proportional to the load current as shown in Figure 7b. Figure 7c shows the transient response with the AVP function. The AVP voltage droop reduces the peak-to-peak output voltage perturbation. As a result, the AVP topology requires fewer capacitors at the regulator output to achieve the same voltage tolerance window.

The AVP circuit obtains the load current information from the sense resistor or the inductor DCR as shown in Figure 8. The voltage drop across the sense resistor is extracted

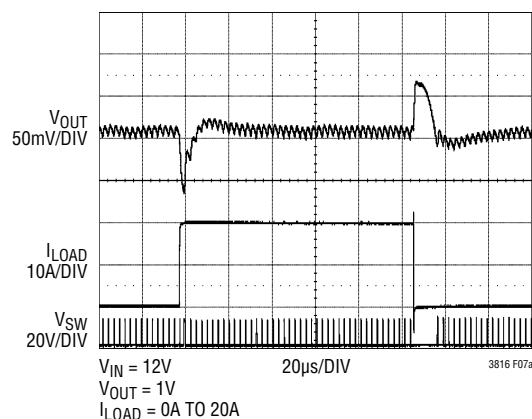

Figure 7a. Transient Waveform Without AVP. The Transient Peak-to-Peak Spike $\approx 130\text{mV}$. The AITC Amplifier is Configured as a Unity-Gain Amplifier

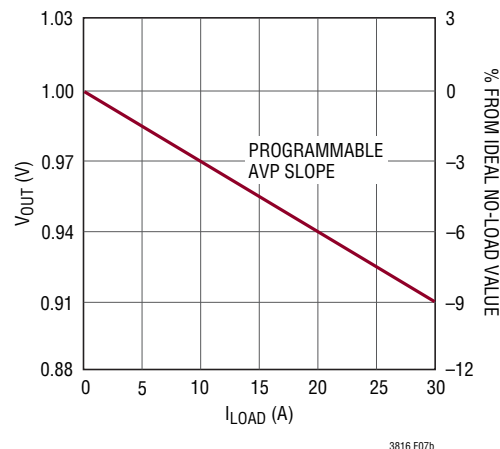

Figure 7b. AVP DC Transfer Curve

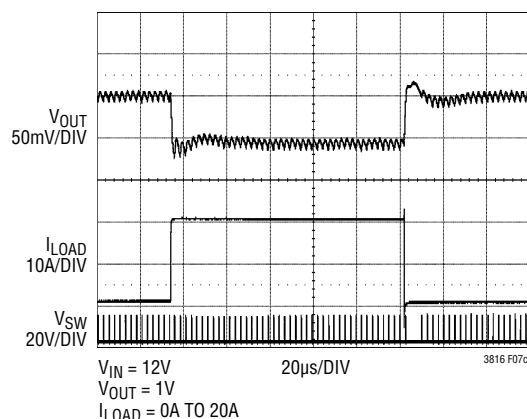

Figure 7c. Transient Waveform with AVP Slope = -3mV/A , Using The Same Inductor and Output Capacitor as Figure 7a. The Transient Peak-to-Peak Perturbation is Reduced to About 85mV

by the AITC amplifier and summed with the differential amplifier output voltage. The resulting output is servoed to the VID DAC voltage. At higher load current, the voltage drop across the sense resistor increases, resulting in a lower switcher output voltage. Typically, the system requirement defines the amount of AVP gain ensuring that the output voltage remains within the regulator supply tolerance band over the full range of load conditions. Figure 8 includes the components required to compensate for the sense resistor parasitic inductance. The AVP DC transfer function is:

$$V_{\text{OUT}} = V_{\text{DAC}} - A_{\text{AVP(SR)}} \cdot I_L = V_{\text{DAC}} - A_{\text{G(SR)}} \cdot I_L \cdot R_{\text{SEN}}$$

APPLICATIONS INFORMATION

where $A_{AVP(SR)}$ is the AVP gain with sense resistor configuration and $A_{G(SR)}$ is the sense resistor gain:

$$A_{AVP(SR)} = A_{G(SR)} \cdot R_{SEN} \text{ and } A_{G(SR)} = \frac{R_{VSR}}{R_{AVPSR}}$$

$$R_{VSR} \cdot C_{VSR} = \frac{ESL}{R_{SEN}}$$

Figure 9 shows the AVP configuration with current sense implemented using the inductor DCR. The AVP DC transfer function is:

$$V_{OUT} = V_{DAC} - A_{AVP(DCR)} \cdot I_L = V_{DAC} - A_{G(DCR)} \cdot I_L \cdot R_{DCR}$$

where:

$$A_{AVP(DCR)} = A_{G(DCR)} \cdot R_{DCR} \text{ and } A_{G(DCR)} = \frac{R_{VDCCR}}{R_{AVPDCR}}$$

$$R_{VDCCR} \cdot C_{VDCCR} = \frac{L}{R_{DCR}}$$

TEMPERATURE COMPENSATED ACTIVE VOLTAGE POSITIONING (AVP) WITH INDUCTOR DCR

The inductor DCR AVP configuration improves the regulator efficiency by eliminating the power losses associated with a sense resistor. However, without proper temperature compensation, the positive temperature coefficient of the inductor DCR, 0.39%/°C, may compromise the output voltage accuracy. As the temperature of the inductor rises, its DCR value increases, resulting in a greater V_{OUT} droop rate (higher AVP gain). To compensate for the DCR temperature shift, replace the resistor R_{VDCCR} in Figure 9 with an NTC resistor placed as close as possible to the inductor. Ideally, the NTC resistor should have the same temperature as the inductor. As temperature increases, the NTC resistance drops, resulting in a reduction in the AITC amplifier voltage gain. This compensates for the increase in DCR resistance and maintains the AVP gain. The NTC resistor, however, is highly nonlinear and must be linearized. Figure 10 shows

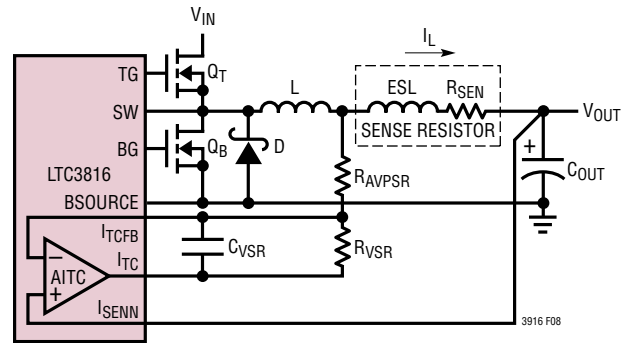

Figure 8. AVP Configuration with a Sense Resistor

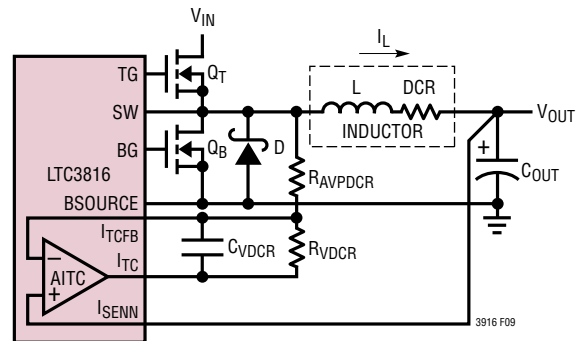

Figure 9. AVP Configuration with Inductor DCR Current Sense

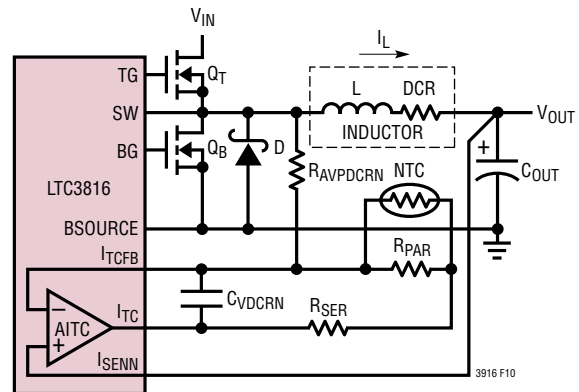

Figure 10. AVP with Inductor DCR Current Sense and NTC Temperature Compensation

APPLICATIONS INFORMATION

the NTC compensation network. To determine the component values, first, select the NTC with room temperature resistance approximately equal to R_{VDCR} that has the smallest temperature coefficient (β constant in the NTC data sheet. Using an NTC with a higher β constant generates a less optimal temperature compensation). Next, calculate the resistances R_{PAR} and R_{SER} from the following equations where the NTC resistances at different temperatures is obtained from the manufacturer's data sheet.

$$R_{PAR} = R_{NTC} \text{ at } 25^{\circ}\text{C}$$

$$R_{SER} \approx \frac{10}{3} \left[(R_{PAR} \parallel (R_{NTC} \text{ at } 0^{\circ}\text{C})) - (R_{PAR} \parallel (R_{NTC} \text{ at } 75^{\circ}\text{C})) \right] - (R_{PAR} \parallel (R_{NTC} \text{ at } 25^{\circ}\text{C}))$$

Note that the above equations optimize temperature compensation at hot. At extreme cold temperature, the temperature compensation is less effective.

With the NTC resistor network, the temperature compensated AVP transfer function becomes:

$$V_{OUT} = V_{DAC} - A_{AVP(DCRN)} \cdot I_L = V_{DAC} - A_{G(DCRN)} \cdot I_L \cdot R_{DCR}$$

where $A_{AVP(DCRN)}$ and $A_{G(DCRN)}$ are the AVP and DCR gain using the inductor DCR current sense with NTC temperature compensation configuration.

$$A_{AVP(DCRN)} = A_{G(DCRN)} \cdot R_{DCR} \text{ and } A_{G(DCRN)} = \frac{R_{NTCNET}}{R_{AVPDCRN}}$$

$$C_{VDCRN} = \frac{L}{R_{NTCNET} \cdot R_{DCR}}$$

$$R_{NTCNET} = [R_{SER} + (R_{PAR} \parallel R_{NTC})]$$

Figure 11a shows the room temperature AVP DC transfer curves obtained using inductor DCR current sense with and without NTC temperature compensation. There is only a slight difference in the transfer curve at heavy load. Figure 11b shows the AVP transfer curve obtained at 125°C, it shows the improvement in AVP accuracy with the NTC resistor network.

Figure 12 shows another easy way to compensate for the inductor DCR temperature coefficient. In this configuration, a linear PTC resistor is connected from the SW node to the I_{TCFB} pin. The PTC thermistor's temperature coefficient of 0.411%/°C compensates for the change in DCR

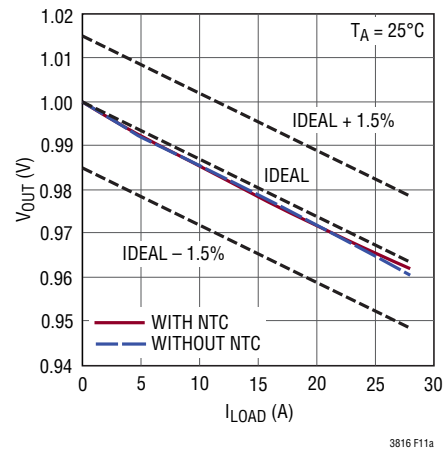

Figure 11a. AVP Transfer Curve Using Vishay IHLP-5050CE-01 0.33µH (DCR = 1.3mΩ) Inductor DCR Current Sense with $A_{G(DCRN)} = 1$ at $T_A = 25^{\circ}\text{C}$

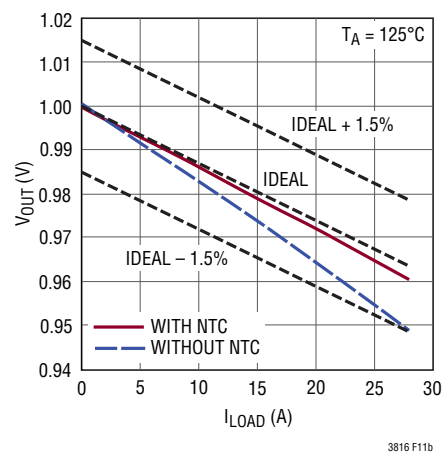

Figure 11b. Same Setup as Figure 11a. Improvement in AVP Accuracy with NTC Temperature Compensation Network at $T_A = 125^{\circ}\text{C}$

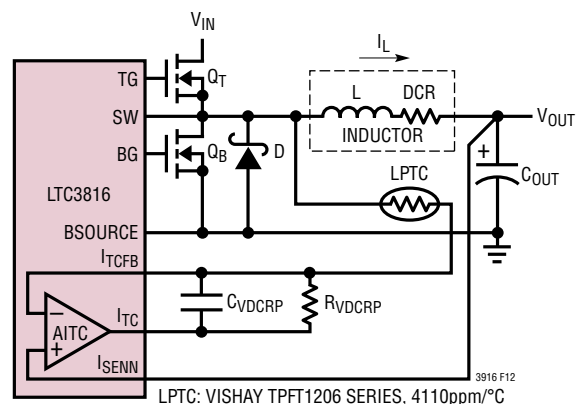

Figure 12. AVP Using Inductor DCR Current Sense with Linear PTC Temperature Compensation

APPLICATIONS INFORMATION

resistance (0.39%/°C) and produces a near perfect AVP slope across temperature.

$$V_{OUT} = V_{DAC} - A_{AVP(DCRP)} \cdot I_L = V_{DAC} - A_{G(DCRP)} \cdot I_L \cdot R_{DCR}$$

where:

$$A_{AVP(DCRP)} = A_{G(DCRP)} \cdot R_{DCR} \text{ and } A_{G(DCRP)} = \frac{R_{VDCRP}}{R_{LPTC}}$$

$$C_{VDCRP} = \frac{L}{R_{VDCRP} \cdot R_{DCR}}$$

I_{MON}

To facilitate CPU monitoring of load current in an IMVP-6.5 application, the LTC3816 forces the I_{MON} pin voltage to be proportional to the average load current. As shown in Figure 13, the AITC and the unity-gain amplifiers force the voltage across the resistor R_{PREIMON} to be equal to the voltage drop across the sense resistor. A current is supplied to R_{IMON} that is three times greater than the current in R_{PREIMON}. The voltage across the R_{IMON} resistor is equal to:

$$V_{IMON} = 3 \cdot (I_L \cdot R_{SEN}) \cdot \frac{R_{VSR}}{R_{AVPSR}} \cdot \frac{R_{IMON}}{R_{PREIMON}}$$

To prevent the ground difference between the CPU and the regulator from affecting the I_{MON} voltage accuracy,

the negative terminal of the resistor R_{IMON} should be connected directly to the CPU V_{SS(SEN)} pin. Depending on the output load requirements, the I_{MON} voltage gain can be programmed by changing the ratio of the R_{IMON} and R_{PREIMON} resistances. A capacitor should be added in parallel with the resistor R_{IMON} to remove the switching ripple. The value of the capacitor C_{IMON} is determined by the following equation:

$$C_{IMON} = \frac{t_{IMON}}{R_{IMON}}$$

where t_{IMON} is the I_{MON} time constant and must be larger than 300µs.

In the IMVP-6.5 configuration, the I_{MON} pin potential is internally clamped to 1.1V with respect to the V_{SS(SEN)} pin voltage. Forcing the PREI_{MON} pin to INTV_{CC} configures the LTC3816 as an IMVP-6 regulator.

FEEDBACK CONTROL

The LTC3816 feedback loop consists of the line feedforward circuit, the modulator, the external inductor, the output capacitor, the AITC and differential amplifier, and the feedback amplifier with its compensation network. All of these components affect loop behavior and need to be accounted for in the loop compensation.

Line Feedforward and Modulator

The modulator consists of the PWM generator, the output MOSFET drivers and the external MOSFETs themselves. The modulator gain varies linearly with the input voltage. The line feedforward circuit compensates for this change in gain and provides a constant gain from the error amplifier output to the SW node regardless of input voltage. From a feedback loop point of view, the combination of the line feedforward circuit and the modulator looks like a linear voltage transfer function from COMP to the SW node and has a gain roughly equal to:

$$A_{MOD} \approx 25V/V \approx 28dB$$

It has a fairly benign AC behavior at typical loop compensation frequencies with significant phase shift appearing at half the switching frequency.

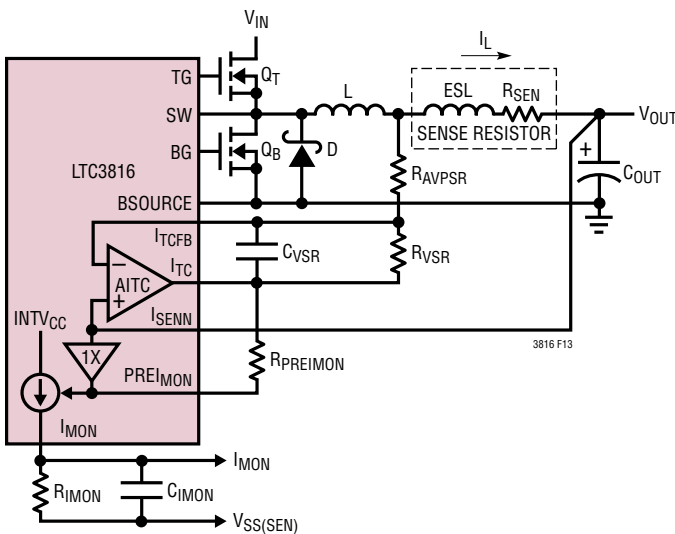

Figure 13. I_{MON} Configuration

APPLICATIONS INFORMATION

LC Filter

The external inductor and output capacitor combination causes a second order LC roll-off at the output with 180° of phase shift. At higher frequencies, the reactance of the output capacitor approaches its ESR, and the roll-off due to the capacitor stops, leaving -20dB/decade and 90° of phase shift. Beyond the ESR zero, the ceramic capacitor creates a high frequency pole. The LC filter transfer function, poles and zero locations are given by the following equations:

$$A_{LC} = \frac{V_{OUT}}{V_{SW}} \approx \frac{1 + sR_{ESR} \cdot C_{BULK}}{\left(s^2 L_L C_{OUT} + sR_L C_{OUT} + 1 \right)}$$

$$\cdot \frac{1}{1 + sR_{ESR} \frac{C_{BULK} \cdot C_{CER}}{C_{OUT}}}$$

$$f_{LC(DOUBLE_POLE)} = \frac{1}{2\pi \sqrt{L_L C_{OUT}}}$$

$$f_{ESR(ZERO)} = \frac{1}{2\pi \cdot R_{ESR} \cdot C_{BULK}}$$

$$f_{CER(POLE)} = \frac{1}{2\pi \cdot R_{ESR} \frac{C_{BULK} \cdot C_{CER}}{C_{OUT}}}$$

where:

R_L includes DCR, sense resistance, PCB trace resistance and the turn-on resistance of the power MOSFET.

L_L includes the inductor inductance, PCB trace inductance and sense resistor ESL.

$$C_{OUT} = C_{BULK} + C_{CER}$$

AITC and Differential Amplifiers

With the sense resistor configuration, the AITC and the differential amplifiers add a double zero and a pole in the vicinity of the feedback loop crossover frequency, f_c , and multiple poles at higher frequencies. The simplified low frequency transfer function from the regulator output node to the SERVO pin, as shown in Figure 14a, is given by the following equation:

$$\frac{V_{SERVO}}{V_{OUT}} \approx \frac{1 + sA_{(SR)} + s^2 B_{(SR)}}{1 + sR_{ESR} \cdot C_{BULK}}$$

where:

$$A_{(SR)} = R_{ESR} \cdot C_{BULK} + A_{G(SR)} \cdot R_{SEN} \cdot C_{OUT}$$

$$B_{(SR)} = A_{G(SR)} \cdot R_{SEN} \cdot R_{ESR} \cdot C_{BULK} \cdot C_{CER}$$

Similarly, for the DCR configuration with NTC compensation, the simplified low frequency transfer function is given by:

$$\frac{V_{SERVO}}{V_{OUT}} \approx \frac{1 + sA_{(DCR)} + s^2 B_{(DCR)}}{1 + sR_{ESR} \cdot C_{BULK}}$$

where:

$$A_{(DCR)} = R_{ESR} \cdot C_{BULK} + A_{G(DCR)} \cdot R_{DCR} \cdot C_{OUT}$$

$$B_{(DCR)} = A_{G(DCRN)} \cdot R_{DCR} \cdot R_{ESR} \cdot C_{BULK} \cdot C_{CER}$$

Note that with either the sense resistor or the DCR current sense configuration, the AVP circuitry introduces a pole at the same location as the LC lowpass filter ESR zero. This cancels the increase in gain and phase caused by the ESR zero. Fortunately, the zero in the AVP transfer function is typically within the closed-loop bandwidth and provides a beneficial phase boost at the crossover frequency.

Error Amplifier

The error amplifier provides most of the low frequency loop gain and serves the switcher output voltage to the VID DAC potential minus the AVP droop. After selecting the inductor, the output capacitor and the AVP component values, the control loop is compensated by tailoring the frequency response of the error amplifier. A typical LTC3816 application uses Type 3 compensation to frequency compensate the feedback loop. Figure 14a and Figure 14b show the LTC3816 error amplifier Type 3 configuration. The transfer function of this amplifier is given by the following equation:

$$\frac{V_{COMP}}{V_{SERVO}} = - \frac{(1 + sR_C \cdot C_C)(1 + sR_1 \cdot C_{FF})}{sR_1(C_C + C_{C1}) \left(1 + sR_C \frac{C_C \cdot C_{C1}}{C_C + C_{C1}} \right)}$$

The error amplifier component values can be obtained using the following guidelines.

APPLICATIONS INFORMATION

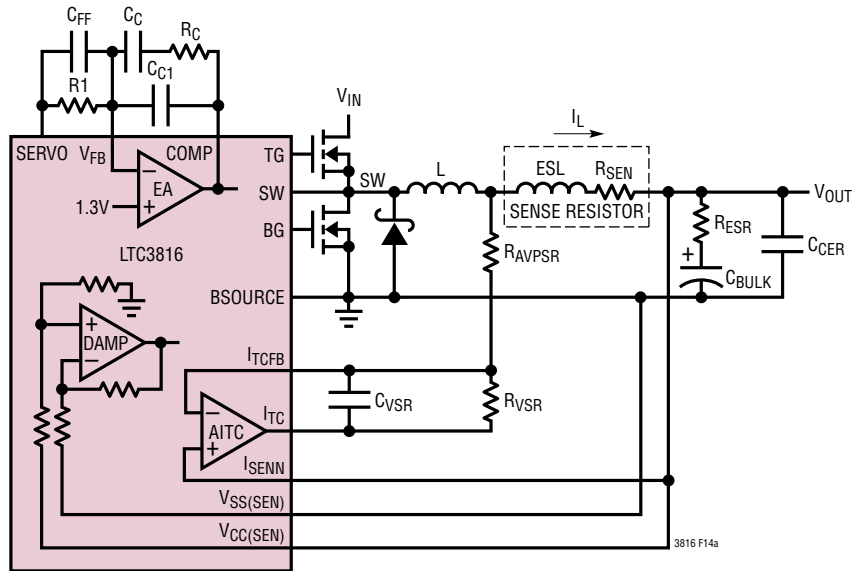

Figure 14a. LTC3816 Frequency Compensation with Sense Resistor Configuration

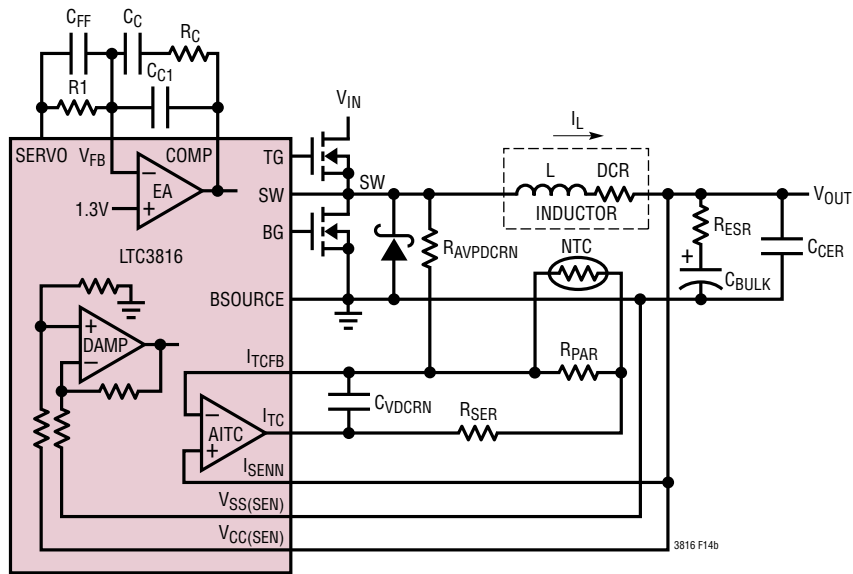

Figure 14b. LTC3816 Frequency Compensation with DCR Configuration

APPLICATIONS INFORMATION

1. Select f_C = feedback crossover frequency = $\frac{f_{OSC}}{N}$
where N is between 5 and 10.
2. At the feedback loop crossover frequency, f_C , the loop gain is unity, therefore the error amplifier gain is:

$$\frac{V_{COMP}}{V_{SERVO}} = \frac{1}{A_{MOD} \cdot A_{LC} \cdot \frac{V_{SERVO}}{V_{OUT}}}$$

3. Place the error amplifier zero near the LC filter double-pole frequency:

$$f_{EA(ZERO)} = \frac{1}{2\pi \cdot R_C \cdot C_C} \approx \frac{1}{2\pi \sqrt{L_L C_{OUT}}}$$

4. The feedforward zero is positioned to give the required phase boost at the crossover frequency:

$$f_{FF(ZERO)} = \frac{1}{2\pi \cdot R1 \cdot C_{FF}}$$

5. Place the error amplifier pole at $5f_C$ to suppress the switching noise.

$$f_{EA(POLE)} = \frac{1}{2\pi \cdot R_C \left(\frac{C_C \cdot C_{C1}}{C_C + C_{C1}} \right)} = 5f_C$$

Compensating the switching power supply voltage feedback loop is a complex task. The frequency compensation equations shown in this data sheet were obtained using some approximations to simplify the calculations. The compensation values shown in this data sheet are typical values, optimized for the power components shown in the circuit. Though similar power components should suffice, substantially changing even one major power component or circuit layout may degrade performance significantly. To verify the calculated component values, all new circuit designs should be prototyped and tested for stability.

LINE FEEDFORWARD (LFF)

The LTC3816 incorporates a line feedforward function to compensate for changes in the line voltage and to simplify the frequency compensation. On the other hand, with the line feedforward enabled, the feedback loop has high modulator gain and is more sensitive to noise pickup. If the input supply voltage is low (e.g., around 5V) and well regulated, it is better to disable the LFF function by shorting the LFF pin to GND. Without LFF, the modulator gain $A_{MOD(WOLFF)}$ is reduced and the control loop is less sensitive to noise injection.

$$A_{MOD(WOLFF)} \approx 0.85 \cdot V_{IN}$$

If line feedforward is disabled, the control loop needs to be recomensated in order to account for the reduction in modulator gain.

DPRSLPVR AND VID DAC SLEW RATE CONTROL

The LTC3816 allows the user to program the VID DAC voltage transition slew rate by adding a capacitor at the CSLEW pin. In the IMVP-6.5 mode, CSLEW is internally pulled up by a 40 μ A current source. Upon a code transition command, CSLEW is ramped up by the internal current source. When the capacitor, C_{SLEW} , potential reaches 1V, the VID DAC output voltage jumps by 1 LSB (12.5mV) and the controller resets the C_{SLEW} capacitor. This operation repeats until the DAC reaches its target value. The DAC voltage slew rate is given by the following equation:

$$\frac{dV_{DAC}}{dt} = 12.5mV \cdot \frac{I_{CSLEW}}{C_{SLEW}}$$

where $I_{CSLEW} = 40\mu A$.

When the IMVP-6 configuration is selected, the LTC3816 allows two different slew rates as shown in Figure 15. To configure the normal slew rate, short the pin DPRSLPVR to ground. To configure for a slower slew rate, force the DPRSLPVR pin potential above 1.6V. 25 μ s after the controller detects a low-to-high transition at the DPRSLPVR pin,

APPLICATIONS INFORMATION

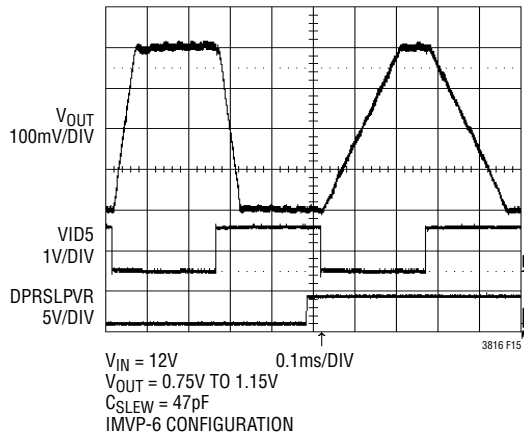

Figure 15. Programmable VID Slew Rate

the controller reduces the I_{CSLEW} pull-up current from $40\mu A$ to $10\mu A$ (deeper sleep mode). This effectively reduces the VID DAC slew rate to 1/4 of its original value. If IMVP-6.5 is selected, the slow slew rate function is disabled.

PULSE-SKIPPING AND FORCED CONTINUOUS MODE OPERATION

The LTC3816 can operate in one of two modes selectable with the MODE/SYNC pin: pulse-skipping mode or forced continuous mode. Shorting the MODE/SYNC pin to $INTV_{CC}$ selects pulse-skipping mode. Pulse-skipping mode is selected when high efficiency at very light loads is desired. In this mode, when the inductor current reverses, the bottom MOSFET turns off to minimize the efficiency loss due to reverse current flow. This reduces the conduction loss and slightly improves the efficiency. As the load reduces, the top gate duty cycle shrinks to maintain regulation. The LTC3816 is capable of operating at extremely low duty cycles; hence, TG will continue to run at a constant switching frequency until the top gate on-time is less than 40ns to 50ns. When the load decreases beyond this point, the LTC3816 TG begins to skip cycles to maintain regulation. The driver switching frequency

drops, which further improves efficiency by minimizing gate charge losses.

Forcing the MODE/SYNC pin low enables forced continuous mode operation. In forced continuous mode, the bottom MOSFET is always on when the top MOSFET is off, allowing the inductor current to reverse at low currents. This mode is less efficient due to conduction and switching losses, but has the advantage of better transient response at low currents, constant frequency operation, and the ability to maintain regulation when sinking current.

During soft-start, the LTC3816 forces the controller to operate in pulse-skipping mode until the switcher output voltage reaches its V_{BOOT} power good threshold. During VID code transitions, however, the controller always operates in forced continuous mode to allow the switcher to sink current.

OPERATING FREQUENCY/FREQUENCY SYNCHRONIZATION

The selection of switching frequency is a trade-off between efficiency and component size. Low frequency operation increases efficiency by reducing MOSFET switching losses, but requires a larger inductance and/or capacitance to maintain low output voltage ripple. For converters with high step-down V_{IN} -to- V_{OUT} ratios, another consideration is the minimum on-time of the converter.

$$t_{ON(MIN)} = \frac{V_{OUT}}{V_{IN(MAX)} \cdot f_{OSC}}$$

If the MODE/SYNC pin is not driven by an external clock, the RFREQ pin voltage configures the LTC3816 free-running switching frequency. Floating or shorting the RFREQ pin to $INTV_{CC}$ allows the controller to run at the nominal 400kHz frequency. Connecting the RFREQ pin to GND selects 210kHz. Tying RFREQ to a potential between 2.5V and 3.5V selects 580kHz. The RFREQ pin has an internal

APPLICATIONS INFORMATION

10 μ A current source pull-up. Placing a resistor between RFREQ and GND creates a potential given by the following equation:

$$V_{RFREQ} = I_{RFREQ} \cdot R_{RFREQ}$$

where $I_{RFREQ} = 10\mu\text{A}$ and allows the oscillator free-running frequency to be programmed between 210kHz to 580kHz as shown in Figure 16.

An internal phase-locked loop (PLL) allows the LTC3816 to synchronize the internal oscillator to an external clock. When there is a clocking signal at the MODE/SYNC pin, the LTC3816 phase detector adjusts the internal PLL VCO input, synchronizing the switching frequency to the external clock frequency, and aligning the TG falling edge to the external clock's falling edge. During synchronization, the oscillator frequency range widens to 120kHz to 650kHz.

For rapid frequency lock-in, the VCO input voltage can be pre-biased to the desired operating frequency before the external clock is applied. A resistor connected between the RFREQ pin and GND can pre-bias the VCO's input voltage to the desired potential. Once pre-biased, the PLL loop only needs to make slight changes to the VCO input voltage in order to synchronize. The ability to pre-bias the loop filter allows the PLL to lock-in rapidly.

CLKEN#, OVF AND PWRGD

CLKEN# is an open-drain output used to enable the CPU's PLL. Upon power-up, this open-drain pull-down is disabled, and CLKEN# is pulled high by an external resistor. During the soft-start ramp, when the switcher output is 45mV from the V_{BOOT} voltage, the controller completes its soft-start cycle and 75 μ s later, CLKEN# pulls low to enable the processor PLL as shown in Figure 2.

At any instant, if the switcher output voltage rises above the OVF threshold, the PWRGD pulls low, the regulator output voltage is actively ramped to 0V and PWRGD remains latched low until either the power is cycled or V_{RON} toggles. In the IMVP-6 configuration, the maximum OVF threshold is 1.7V. In the IMVP-6.5 configuration, the maximum threshold reduces to 1.55V.

The PWRGD pin is an open-drain output that indicates the regulator output voltage has stabilized. At start-up, once the switcher output has settled to its VID potential for more than 10ms, this open-drain releases and is pulled high by the external pull-up resistor. It pulls low again if the switcher output voltage remains outside of the +175mV/-270mV window around its nominal VID set point for more than 750 μ s. Once pulled low, the PWRGD state is latched and the control logic initiates a shutdown sequence. After the

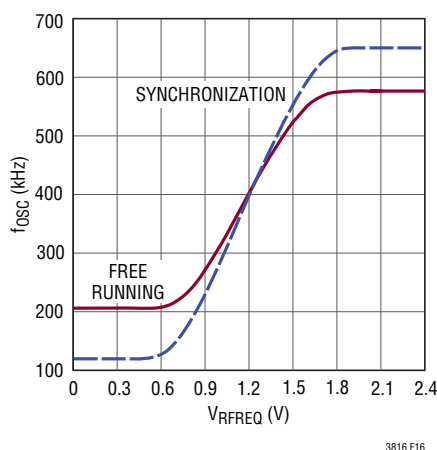

Figure 16. VCO Transfer Curve

APPLICATIONS INFORMATION

output voltage is ramped down, the controller continues to hold the regulator output and PWRGD low until the VR_{ON} pin toggles or the input supply resets.

During a VID transition, the power good comparators are masked for 100 μ s. In deeper sleep mode (25 μ s after DPRSLPVR pin transitions high), the power good comparators are disabled and PWRGD stays high unless the switcher output voltage rises above its overvoltage fault threshold OVF or the controller detects that the regulator output voltage is 370mV lower than its nominal value.

The LTC3816 PWRGD pin can be configured for wire-OR operation. Shorting PWRGD to ground externally triggers a latching function. The regulator forces the output to a zero voltage condition and stays in this state until either the VR_{ON} pin or the input supply resets.

VRTT# AND THERMAL SHUTDOWN

The LTC3816 includes a thermal monitoring circuit that senses the potential at the RPTC pin. An internal 100 μ A pull-up current source connects to an external nonlinear PTC thermistor through this pin. At room temperature, the low resistance PTC creates a low voltage at the RPTC pin. At high temperatures, the PTC resistance increases exponentially. If the resulting RPTC voltage is higher than 0.47V, it trips the thermal monitor comparator, causing the open-drain pin VRTT# to pull low signaling an overtemperature

event. The controller continues its normal operation with no disruption to the output voltage. To reset this thermal comparator, the voltage at the RPTC pin must drop below 0.1V. To accurately reflect the system temperature, the nonlinear PTC thermistor should be mounted as close as thermally possible to the hottest device, e.g., the inductor or the MOSFET. To prevent the switching noise from affecting the thermal sensing circuit, add a small capacitor near the RPTC pin.

Figure 17 shows the Murata PTC PRF18 series typical resistance-temperature characteristics. At room temperature, all parts have about 470 Ω nominal resistance. At higher temperatures, the resistance increases exponentially. An overtemperature event is detected by the LTC3816 when the PTC thermistor's resistance exceeds 4.7k. By selecting the appropriate thermistor from the series, this thermal monitoring threshold can be set anywhere from 65 $^{\circ}$ C to 145 $^{\circ}$ C with 10 $^{\circ}$ C resolution.

The LTC3816 includes a second thermal protection feature. If the LTC3816 die temperature is higher than 150 $^{\circ}$ C, the controller pulls down the VRTT# pin. Under this condition the CPU should initiate its thermal management operation. To untrip the VRTT# flag, the die temperature must be dropped below 130 $^{\circ}$ C. If the LTC3816 die temperature exceeds 165 $^{\circ}$ C, the driver is disabled and the controller is latched in a thermal shutdown state until the power supply is cycled or the VR_{ON} input toggles.

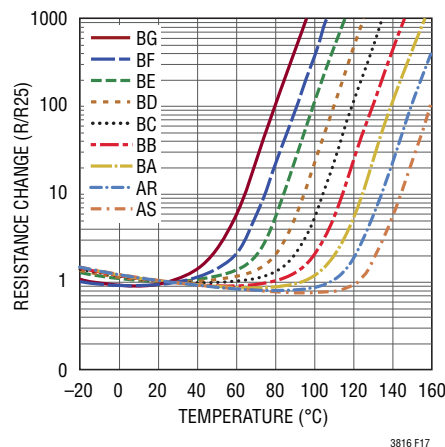

Figure 17. Murata Nonlinear PTC PRF18 Series Typical Resistance-Temperature Characteristics. Extracted From Murata PTC PRF18471QB1RB Data Sheet**

APPLICATIONS INFORMATION

POWER MOSFET AND SCHOTTKY DIODE SELECTION

The LTC3816 requires two external N-channel power MOSFETs: One for the top (main) switch and one (or more) for the bottom (synchronous) switch.

The peak-to-peak MOSFET gate drive levels are set by the 5.2VINTV_{CC} supply, requiring the use of logic-level threshold MOSFETs in most applications. Pay close attention to the BV_{DSS} specification for the MOSFETs as well; many logic-level MOSFETs are limited to 30V or less.

Selection criteria for the power MOSFETs includes the input capacitance, the on-resistance R_{DS(ON)}, the input voltage and the maximum output current. MOSFET input capacitance is a combination of several components but can be derived from the typical *gate-charge* curve included on most data sheets as shown in Figure 18. The curve is generated by forcing a constant input current into the gate of a common source, current source loaded stage and then plotting the gate voltage versus time. The initial slope is the effect of the gate-to-source and the gate-to-drain capacitances. The flat portion of the curve is the result of the Miller multiplication effect of the drain-to-gate capacitance as the drain drops the voltage across the current source load. The upper sloping line is due to the drain-to-gate accumulation capacitance and the gate-to-source capacitance.

The Miller charge (the increase in coulombs on the horizontal axis from A to B while the curve is flat) is specified for a given V_{DS} drain voltage, but can be adjusted for different V_{DS} voltages by multiplying the ratio of the application V_{DS} to the curve specified V_{DS} values. A way to

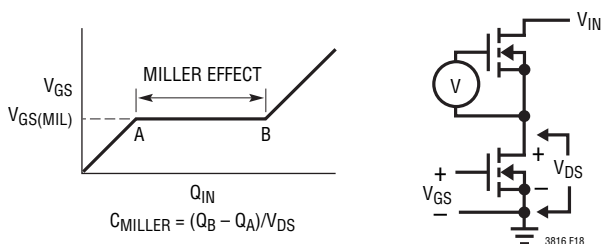

Figure 18. MOSFET Miller Capacitance

estimate the C_{MILLER} term is to take the change in gate charge from points A and B on a manufacturer's data sheet and divide by the stated V_{DS} voltage specified. C_{MILLER} is the most important selection criteria for determining the transition loss term in the top MOSFET but is not directly specified on MOSFET data sheets. C_{RSS} and C_{OSS} are specified sometimes but definitions of these parameters are not included.

When the controller is operating in continuous mode the duty cycles for the top and bottom MOSFETs are given by:

$$\text{Main Switch Duty Cycle} = \frac{V_{\text{OUT}}}{V_{\text{IN}}}$$

$$\text{Synchronous Switch Duty Cycle} = \frac{V_{\text{IN}} - V_{\text{OUT}}}{V_{\text{IN}}}$$

The power dissipation for the main and synchronous MOSFETs at maximum output current are given by:

$$P_{\text{MAIN}} = \frac{V_{\text{OUT}}}{V_{\text{IN}}} (I_{\text{LOAD(MAX)}})^2 (1 + \delta) R_{\text{DS(ON)}} + (V_{\text{IN}})^2 \frac{I_{\text{LOAD(MAX)}}}{2} (R_{\text{DR}}) (C_{\text{MILLER}}) \cdot \left(\frac{1}{V_{\text{INTVCC}} - V_{\text{GS(MIL)}}} + \frac{1}{V_{\text{GS(MIL)}}} \right) (f_{\text{OSC}})$$

$$P_{\text{SYNC}} = \frac{V_{\text{IN}} - V_{\text{OUT}}}{V_{\text{IN}}} (I_{\text{LOAD(MAX)}})^2 (1 + \delta) R_{\text{DS(ON)}}$$

where δ is the temperature dependency of R_{DS(ON)} and R_{DR} is the effective top driver resistance (approximately 2.6 Ω). V_{GS(MIL)} is the MOSFET V_{GS} at the Miller effect transition. C_{MILLER} is the calculated capacitance using the gate-charge curve from the MOSFET data sheet as described above. The term (1 + δ) is generally given for a MOSFET in the form of a normalized R_{DS(ON)} versus temperature curve, but $\delta = 0.005/^{\circ}\text{C}$ can be used as an approximation for low voltage MOSFETs.

APPLICATIONS INFORMATION

Both MOSFETs have I^2R losses while the topside N-channel equation includes an additional term for transition losses, which are highest at the highest input voltage. The number, type and on-resistance of all MOSFETs selected take into account the voltage step-down ratio as well as the actual position (main or synchronous) in which the MOSFET is used. A much smaller, lower input capacitance MOSFET should be used for the top MOSFET in applications where $V_{IN} \gg V_{OUT}$. The top MOSFET's on-resistance is normally less important for overall efficiency than its input capacitance at operating frequencies above 300kHz. MOSFET manufacturers have designed special purpose devices that provide reasonably low on-resistance with significantly reduced input capacitance for the main switch in switching regulators. The synchronous MOSFET losses are greatest at high input voltages when the top switch duty cycle is low or during a short circuit when the synchronous switch is on close to 100% of the period.

The Schottky diode, D, shown in Figure 1 conducts during the dead-time between the conduction of the two large power MOSFETs. This prevents the body diode of the bottom MOSFET from turning on, storing charge during the dead time and requiring a reverse-recovery period which could cost as much as several percent in efficiency. Due to the relatively small average current, a 2A to 8A Schottky is generally acceptable while offering a good compromise between series resistance and capacitance. Larger diodes result in additional transition loss due to their larger junction capacitance.

C_{IN} SELECTION

In continuous mode, the source current of the top N-channel MOSFET is a square wave of duty cycle V_{OUT}/V_{IN} . To prevent large voltage transients, a low ESR input capacitor sized for the maximum RMS current must be used. The maximum RMS capacitor current is given by:

$$I_{RMS(MAX)} \approx I_{LOAD(MAX)} \frac{\sqrt{V_{OUT}(V_{IN} - V_{OUT})}}{V_{IN}}$$

This equation has a maximum RMS current at $V_{IN} = 2V_{OUT}$, where $I_{RMS(MAX)} = I_{LOAD(MAX)}/2$. This simple worst-case condition is commonly used for design because even significant deviations do not offer much relief. A typical LTC3816 application operates at low duty cycle, hence, the maximum input supply ripple current occurs at $V_{IN} = V_{IN(MIN)}$, and typically $I_{RMS(MAX)} < I_{LOAD(MAX)}/2.5$.

Note that capacitor manufacturers' ripple current ratings are often based on only 2000 hours of life. This makes it advisable to further derate the capacitor or to choose a capacitor rated at a higher temperature than required. Several capacitors may also be paralleled to meet size or height requirements in the design. Sanyo OS-CON SVP, SVPD series or aluminum electrolytic capacitors from Panasonic WA series in parallel with a couple of high performance ceramic capacitors should be used as the input supply bypass. Ceramic capacitors placed next to the top MOSFET drain helps to reduce the input supply voltage ripple.

C_{OUT} SELECTION

The output capacitor choice is primarily determined by the voltage tolerance specifications due to large load current transients encountered in typical LTC3816 applications. The capacitance must be sufficient to absorb the change in inductor current when a high current to low current transition occurs. The opposite load current transition is generally determined by the control loop compensation components, so make sure not to overcompensate and slow down the response. The minimum capacitance to assure the inductor's energy is adequately absorbed is:

$$C_{BULK} + C_{CER} = \frac{L(\Delta I_{LOAD})^2}{2V_{OUT}(\Delta V_{OUT(LOAD)})}$$

where C_{BULK} is the amount of bulk capacitance and C_{CER} is the total amount of ceramic capacitance. To minimize the output voltage overshoot during a load step, set:

$$\Delta V_{OUT(LOAD)} = \Delta V_{OUT(AVP)}$$

APPLICATIONS INFORMATION

The resistive component of the bulk capacitor ESR must be small enough that under a load release, ESR multiplied by the change in load current must meet the following criteria:

$$\Delta V_{\text{OUT(LOAD)}} > \Delta I_{\text{LOAD}} \cdot R_{\text{ESR}}$$

The ceramic capacitors at the regulator output help to absorb some of the change in the load current and reduce the ESR voltage step predicted by the above equation. High performance ceramic capacitors also help to lower the regulator output voltage perturbation caused by the high slew rate change in the inductor current flowing through the bulk capacitor parasitic ESL.

The total amount of output capacitance required is also restricted by the steady-state output voltage ripple. The output ripple, ΔV_{OUT} , in continuous mode is determined by:

$$\Delta V_{\text{OUT}} \approx \Delta I_L \left(R_{\text{ESR}} + \frac{1}{8 \cdot f_{\text{OSC}} \cdot (C_{\text{BULK}} + C_{\text{CER}})} \right)$$

where f_{OSC} = operating frequency and ΔI_L = ripple current in the inductor. The output ripple is highest at maximum input voltage since ΔI_L increases with input voltage. The first term in the ripple voltage equation relates to the ripple current into the ESR of the output capacitor, which dominates the output ripple voltage. The second term guarantees that the output capacitance does not significantly discharge during the operating frequency period due to ripple current.

Note that the IMVP-6 or IMVP-6.5 application specifies extremely low output voltage deviations. Therefore, the output capacitor selection should be carefully considered. The regulator should be located in close proximity to the CPU. The bulk capacitor needs to be as close as possible to the power supply pins of the processor to minimize the parasitic inductance between the decoupling capacitor and the load. In addition, multiple high performance ceramic capacitors are normally placed in the processor socket cavity to compensate for the PCB parasitic resistance and inductance.

The Sanyo OS-CON semiconductor electrolyte capacitor is one possible choice for high performance through-hole capacitors. In surface mount applications, multiple parallel capacitors are required to meet the ESR or transient current handling requirements. Aluminum electrolytic and dry tantalum capacitors are both available in surface mount configurations. New special polymer surface mount capacitors offer very low ESR but have much lower capacitive density per unit volume. In the case of tantalum, it is critical that the capacitors are surge tested for use in switching power supplies. Several excellent output capacitor choices are the Sanyo POSCAP TPF, TPL and TPLF, or the Panasonic SP series. Consult the manufacturer for other specific recommendations.

INDUCTOR SELECTION

The inductor in a typical LTC3816 circuit is chosen primarily for its saturation current and inductance value. The inductor DC rated current should be larger than the expected peak current which is equal to:

$$I_{L(\text{PEAK})} = I_{\text{LOAD}(\text{MAX})} + \frac{\Delta I_{L(\text{MAX})}}{2}$$

In addition, the selected inductor must be able to withstand $2 \times I_{\text{LOAD}(\text{MAX})}$ for a short duration without saturation (see the Current Limit section).

The inductor value sets the ripple current, which is commonly chosen at around 20% to 30% of the anticipated full load current. Higher inductance reduces ripple current, core losses in the inductor, ESR losses in the output capacitors and output voltage ripple. But, under rapid loading conditions, higher inductance results in higher peak-to-peak transient deviations. A lower value inductor reduces the number of output capacitors and requires a smaller PCB footprint for the LC filter. Highest efficiency operation is obtained at low frequency with small ripple current. However, achieving this requires a large inductor and higher output ripple under transient conditions. There is a trade-off between component size, efficiency

APPLICATIONS INFORMATION

and operating frequency. Given a specified limit for ripple current, the inductor value can be obtained using the following equation:

$$L = \frac{V_{OUT}}{f_{OSC} \cdot \Delta I_{L(MAX)}} \left(1 - \frac{V_{OUT}}{V_{IN(MAX)}} \right)$$

Once the value for L is known, the type of inductor must be selected. High efficiency converters generally cannot afford the core loss found in low cost powdered iron cores, forcing the use of more expensive ferrite cores. Ferrite designs have very low core loss and are thus preferred at high switching frequencies. Ferrite core materials saturate *hard*, which means that inductance collapses abruptly when the peak design current is exceeded. This results in an abrupt increase in inductor ripple current and consequent output voltage ripple. Do not allow the core to saturate! A variety of inductors designed for high current, low voltage applications are available from manufacturers such as Vishay, Sumida, Pulse, Würth Elektronik, Vitec and Toko.

AUTOMOTIVE CONSIDERATIONS

Before you connect an LTC3816 converter to an automotive cigarette lighter supply, be advised: you are plugging into the supply from hell. The main battery line in an automobile is the source of a number of nasty potential transients, including load dump, reverse battery and double battery.

Load dump is the result of a loose battery cable. When the cable breaks connection, the field collapse in the alternator can cause a positive spike as high as 60V which takes several hundred milliseconds to decay. Reverse battery is just what it says, while double battery is a consequence of tow truck operators finding that a 24V jump start cranks cold engines faster than 12V.

The network shown in Figure 19 is the most straightforward approach to protect a DC/DC converter from the ravages of an automotive battery line. The series diode prevents current from flowing during reverse battery, while the

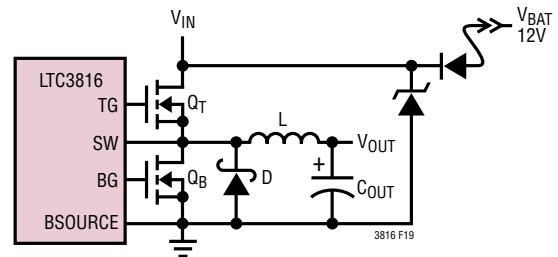

Figure 19. Automotive Application Protection

transient suppressor clamps the input voltage during load dump. Note that the transient suppressor should not conduct during double-battery operation, but must still clamp the input voltage below breakdown of the converter. Although the IC has a maximum input voltage of 40V on the SW pins, most applications will be limited to 30V by the MOSFET BV_{DSS} .

CHECKING TRANSIENT RESPONSE

For all new LTC3816 PCB circuits, transient tests need to be performed to verify the proper feedback loop operation. The regulator loop response can be checked by looking at the load current transient response. Switching regulators take several cycles to respond to a step in DC (resistive) load current. When a load step occurs, V_{OUT} shifts by an amount equal to ΔV_{AVP} . ΔI_{LOAD} also begins to charge or discharge C_{OUT} generating the feedback error signal that forces the regulator to adapt to the current change and return V_{OUT} to its steady-state value. During this recovery time V_{OUT} can be monitored for excessive overshoot or ringing, which would indicate a stability problem.

Measuring transient response presents challenges in two respects: obtaining an accurate measurement and generating a suitable transient to use to test the circuit. Output measurements should be taken with a scope probe directly across the output capacitor. Proper high frequency probing techniques should be used. In particular, don't use the 6" ground lead that comes with the probe! Use an adapter that fits on the tip of the probe and has a short ground clip to ensure that inductance in the ground path doesn't cause a bigger spike than the transient signal being measured.

APPLICATIONS INFORMATION

Conveniently, the typical probe tip ground clip is spaced just right to span the leads of a typical output capacitor. In general, it is best to take this measurement with the 20MHz bandwidth limit on the oscilloscope turned on to limit high frequency noise. Note that microprocessor manufacturers typically specify ripple $\leq 20\text{MHz}$, as energy above 20MHz is generally radiated and not conducted and will not affect the load even if it appears at the output capacitor.

Now that we know how to measure the signal, we need to have something to measure. The ideal situation is to use the actual load for the test, and switch it on and off while watching the output. If this isn't convenient, a current step generator is needed. This generator needs to be able to turn on and off in nanoseconds to simulate a typical switching logic load, so stray inductance and long clip leads between the LTC3816 and the transient generator must be minimized.

Figure 20 shows an example of a simple transient generator. Be sure to use a noninductive resistor as the load element—many power resistors use an inductive spiral pattern and are not suitable for use here. A simple solution is to take ten 1/4W film resistors and wire them in parallel to get the desired value. This gives a noninductive resistive load which can dissipate 2.5W continuously or 50W if pulsed with a 5% duty cycle, enough for most LTC3816 circuits. Solder the MOSFET and the resistor(s) as close to the output of the LTC3816 circuit as possible and set up the signal generator to pulse at a 100Hz rate with a 5% duty cycle. This pulses the LTC3816 with 500 μs transients 10ms apart, adequate for viewing the entire transient recovery time for both positive and negative transitions while keeping the load resistor cool.

A DESIGN EXAMPLE

As a design example, consider an IMVP-6.5 application with inductor DCR current sense (see the last page schematic) and the following requirements: assume $V_{IN} = 12\text{V}$ (nominal), $V_{IN} = 24\text{V}$ (maximum), $V_{OUT} = 0.75\text{V}$, V_{OUT} (minimum) = 0.725V, $I_{LOAD(MAX)} = 27\text{A}$, $I_{LOAD(MIN)} = 1.5\text{A}$, $AVP = -3\text{mV/A}$, $f_{OSC} = 400\text{kHz}$, $V_{IMON} = 1.0\text{V}$.

For the input and output conditions given above, the steady-state minimum on-time for this application at $V_{IN} = 24\text{V}$ is approximately:

$$t_{ON(MIN)} = \frac{V_{OUT(MIN)}}{V_{IN(MAX)} \cdot f_{OSC}} = \frac{0.725\text{V}}{24\text{V} \cdot 400\text{kHz}} = 75.5\text{ns}$$

This is much longer than the LTC3816 minimum on-time.

To program the 400kHz operation, float the RFREQ pin. The inductance value is chosen first based on a 20% ripple current assumption. The highest value of ripple current occurs at the maximum input voltage:

$$L = \frac{V_{OUT}}{f_{OUT} \cdot \Delta I_{L(MAX)}} \left(1 - \frac{V_{OUT}}{V_{IN(MAX)}} \right) \\ = \frac{0.75\text{V}}{400\text{kHz} \cdot 0.2 \cdot 27\text{A}} \left(1 - \frac{0.75\text{V}}{24\text{V}} \right) = 0.33\mu\text{H}$$

A commonly available 0.33 μH inductor is chosen. This results in 5.5A of ripple current. The peak inductor current is the maximum DC load current plus one-half the ripple current, or:

$$I_{L(PEAK)} = 27\text{A} + \frac{1}{2} \cdot 5.5\text{A} = 29.75\text{A}$$

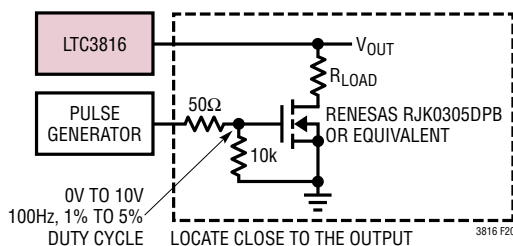

Figure 20. Transient Load Generator PC Board

APPLICATIONS INFORMATION

For this example, a Vishay IHLP-5050CE-01 0.33μH inductor is chosen. According to the inductor data sheet, it has a maximum DC current rating of 36.5A and a saturation current of 62A. At room temperature, the typical DCR is 1.3mΩ and the maximum DCR is 1.5mΩ. At 125°C, the DCR increases to approximately 2.085mΩ. The R_{IMAX} resistor value can be calculated.

$$R_{IMAX} = \left(I_{LIMIT} + \frac{\Delta I_L}{2} \right) \frac{R_{DCR}}{I_{IMAX(MIN)}}$$

$$= 29.75A \cdot \frac{2.085m\Omega}{9\mu A} = 6.89k$$

Choose 1% resistor R_{IMAX} = 6.98k to ensure that the regulator can supply the maximum load current under the worst-case conditions.

If this large DCR variation is a problem, replace this inductor with another inductor with a smaller DCR variation or use an NTC temperature compensation circuit as shown in Figure 21. Please refer to the Temperature Compensated Active Voltage Positioning with Inductor DCR section. Note that Figure 21 uses a resistive divider and requires different component values for optimal temperature compensation.

To derive the voltage drop across the inductor DCR (typically 1.3mΩ), place a 0.1μF capacitor across the current sense input pins, I_{SENP} and I_{SENN}. The current sense filter resistor value R_{IDCR} can be calculated from the equation:

$$R_{IDCR} = \frac{L}{R_{DCR} \cdot C_{IDCR}} = \frac{0.33\mu H}{1.3m\Omega \cdot 0.1\mu F} = 2.538k$$

Select R_{IDCR} = 2.55k.

For the AVP section (refer to Figure 10), first select a 10k NTC thermistor. In this example, the Murata NCP18XH103 is chosen. Next, select:

$$R_{PAR} = R_{NTC} \text{ at } 25^\circ C = 10k$$

The R_{SER} resistor value can be obtained from the following equation:

$$R_{SER} \approx \frac{10}{3} \left[\left(R_{PAR} \parallel (R_{NTC} \text{ at } 0^\circ C) \right) - \left(R_{PAR} \parallel (R_{NTC} \text{ at } 75^\circ C) \right) \right] - \left(R_{PAR} \parallel (R_{NTC} \text{ at } 25^\circ C) \right)$$

From the NTC data sheet:

$$R_{NTC} \text{ at } 0^\circ C = 27.2k$$

$$R_{NTC} \text{ at } 75^\circ C = 1.925k$$

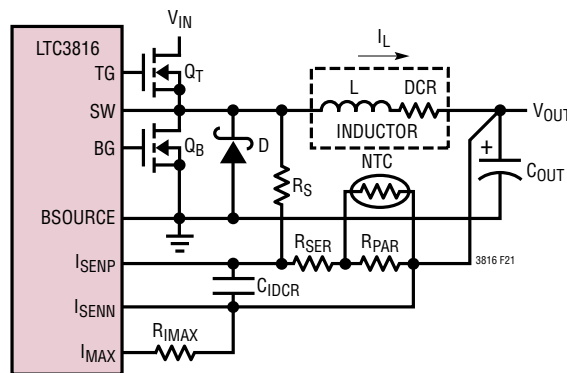

Figure 21. Inductor DCR Current Sense Using NTC Temperature Compensation

APPLICATIONS INFORMATION

Therefore R_{SER} is calculated to be 13.99k and standard value $R_{SER} = 14k$ is used. Next, the resistor $R_{AVPDCRN}$ value is obtained from the AVP slope requirement:

$$A_{AVP} = 3mV/A = \frac{[R_{SER} + (R_{PAR} || R_{NTC})]}{R_{AVPDCRN}} \cdot R_{DCR}$$

$$\Rightarrow R_{AVPDCRN} = \frac{[14k + (10k || 10k)]}{3mV/A} \cdot 1.3m\Omega = 8.233k$$

Select the standard value 8.25k. The capacitor value C_{VDCRN} is given by the following equation:

$$C_{VDCRN} = \frac{L}{[R_{SER} + (R_{PAR} || R_{NTC})] \cdot R_{DCR}}$$

$$= \frac{0.33\mu H}{[14k + (10k || 10k)] \cdot 1.3m\Omega} = 13.36nF$$

Use the standard value $C_{VDCRN} = 15nF$.

To program the I_{MON} voltage, first select the resistor $R_{PREIMON}$ such that $I_{PREIMON}$ bias current is around 10 μ A to 20 μ A:

$$R_{PREIMON} = \frac{I_{LOAD(MAX)} \cdot R_{DCR} \cdot R_{NTCNET}}{I_{PREIMON} \cdot R_{AVPDCRN}}$$

$$= \frac{27A \cdot 1.3m\Omega \cdot [14k + (10k || 10k)]}{15\mu A \cdot 8.25k}$$

$$= 5.389k$$

Select a standard value $R_{PREIMON} = 5.1k$. Once the resistor $R_{PREIMON}$ value is chosen, the R_{IMON} resistor value can be obtained from the following equation:

$$R_{IMON} = \frac{V_{IMON} \cdot R_{PREIMON}}{3 \cdot (I_{LOAD(MAX)} \cdot R_{DCR})} \cdot \frac{R_{AVPDCRN}}{R_{NTCNET}}$$

$$= \frac{1.0V \cdot 5.1k}{3 \cdot (27A \cdot 1.3m\Omega)} \cdot \frac{8.25k}{[14k + (10k || 10k)]}$$

$$= 21.03k$$

Select $R_{IMON} = 21k$. The value of C_{IMON} is selected to satisfy the desired I_{MON} time constant:

$$C_{IMON} = \frac{t_{IMON}}{R_{IMON}} = \frac{300\mu s}{21k} = 14.28nF$$

Select $C_{IMON} = 15nF$.

The power MOSFETs chosen for this application are the Renesas RJK0305DPB (top) and 2 \times RJK0330DPB (bottom). The upper MOSFET, which is optimized for low switching losses, has a typical $R_{DS(ON)}$ of 10m Ω at $V_{GS} = 4.5V$, a total gate charge of 8nC, and a minimum BV_{DSS} of 30V. The bottom MOSFET which is optimized for low on-resistance, has a typical $R_{DS(ON)}$ of 2.8m Ω at $V_{GS} = 4.5V$, a total gate charge of 27nC, and a minimum BV_{DSS} of 30V.

From the RJK0305DPB upper MOSFET data sheet, the Miller capacitance is calculated to be:

$$C_{MILLER} \approx \frac{\Delta Q_G}{\Delta V_{DS}} = \frac{2nC}{12V} = 167pF$$

Assuming a top MOSFET junction temperature of 75 $^{\circ}$ C, $\delta = 0.25$ and the power dissipation in this MOSFET is:

$$P_{MAIN} = \frac{V_{OUT}}{V_{IN}} (I_{LOAD(MAX)})^2 (1 + \delta) R_{DS(ON)} + t$$

$$(V_{IN})^2 \frac{I_{LOAD(MAX)}}{2} (R_{DR}) (C_{MILLER}) \cdot$$

$$\left[\frac{1}{V_{INTVCC} - V_{GS(MIL)}} + \frac{1}{V_{GS(MIL)}} \right] (f_{OSC})$$

$$P_{MAIN} = \frac{0.75V}{12V} (27A)^2 (1 + 0.25) 10m\Omega +$$

$$(12V)^2 \frac{27A}{2} (2.6\Omega) (167pF) \cdot$$

$$\left[\frac{1}{5.2V - 3V} + \frac{1}{3V} \right] (400kHz)$$

$$P_{MAIN} = 0.57W + 0.266W \approx 0.836W$$

APPLICATIONS INFORMATION

For the synchronous MOSFETs, assume that the two bottom MOSFETs share the inductor current equally. The power dissipation for one MOSFET is:

$$P_{\text{SYNC}} = \frac{V_{\text{IN}} - V_{\text{OUT}}}{V_{\text{IN}}} (I_{\text{LOAD(MAX)}})^2 (1 + \delta) R_{\text{DS(ON)}}$$

$$P_{\text{SYNC}} = \frac{12\text{V} - 0.75\text{V}}{12\text{V}} (13.5\text{A})^2 (1 + 0.25) 2.8\text{m}\Omega$$

$$= 0.598\text{W}$$

The total power dissipation of the bottom MOSFETs is $2 \times 0.598\text{W} = 1.196\text{W}$.

For this application, the maximum input RMS current happens when $V_{\text{IN}} = V_{\text{IN(MIN)}}$ and can be determined from the formula:

$$I_{\text{RMS(MAX)}} \approx I_{\text{LOAD(MAX)}} \frac{\sqrt{V_{\text{OUT}} (V_{\text{IN(MIN)}} - V_{\text{OUT}})}}{V_{\text{IN(MIN)}}}$$

$$I_{\text{RMS(MAX)}} \approx 27\text{A} \frac{\sqrt{0.75\text{V} (5\text{V} - 0.75\text{V})}}{5\text{V}} \approx 9.64\text{A}$$

The minimum RMS current rating of the input capacitor must exceed 9.64A. To meet this ripple current requirement with $V_{\text{IN(MAX)}} = 24\text{V}$, select two Sanyo OS-CON 25SVP56 capacitors or higher voltage rating capacitor as the input supply bulk capacitance. In addition, place a couple of high performance ceramic capacitors in parallel with the bulk capacitors.

The output capacitor value is determined by:

$$C_{\text{BULK}} + C_{\text{CER}} = \frac{L (\Delta I_{\text{LOAD}})^2}{2V_{\text{OUT}} (\Delta V_{\text{OUT(LOAD)}})}$$

Most regulator designs allow a slight transient overshoot for a short duration. If this is limited to 40mV, we have:

$$\Delta V_{\text{OUT(AVP)}} = \text{AVP} \cdot (I_{\text{LOAD(MAX)}} - I_{\text{LOAD(MIN)}})$$

$$= 3 \frac{\text{mV}}{\text{A}} \cdot (27\text{A} - 1.5\text{A}) = 76.5\text{mV}$$

$$\Delta V_{\text{OUT(LOAD)}} = \Delta V_{\text{OUT(AVP)}} + \Delta V_{\text{OVERSHOOT}}$$

$$= 76.5\text{mV} + 40\text{mV} = 116.5\text{mV}$$

$$C_{\text{BULK}} + C_{\text{CER}} = \frac{0.33\mu\text{H} (27\text{A} - 1.5\text{A})^2}{2(0.75\text{V})(116.5\text{mV})} = 1228\mu\text{F}$$

The ESR of the output capacitor is determined by the load transient requirement. If the output voltage jump due to the capacitor ESR is limited to $\Delta V_{\text{OUT(AVP)}}$:

$$R_{\text{ESR}} < \frac{\Delta V_{\text{OUT(AVP)}}}{\Delta I_{\text{LOAD}}} = \frac{75\text{mV}}{(27\text{A} - 1.5\text{A})} = 2.94\text{m}\Omega$$

The above requirements are easily satisfied by three Sanyo POSCAP 2TPF330M6 330 μF (ESR = 6m Ω) bulk capacitors in parallel, twenty 10 μF and some 1 μF high performance ceramic capacitors in the processor socket cavity. With three bulk capacitors in parallel, the effective ESR is 2m Ω , and the maximum steady-state output ripple voltage is given by:

$$\Delta V_{\text{OUT}} \approx \Delta I_{\text{L}} \left[R_{\text{ESR}} + \frac{1}{8 \cdot f_{\text{OSC}} \cdot (C_{\text{BULK}} + C_{\text{CER}})} \right]$$

$$= 5.5\text{A} \left[2\text{m}\Omega + \frac{1}{8 \cdot 400\text{kHz} \cdot (3 \cdot 330\mu\text{F} + 20 \cdot 10\mu\text{F})} \right]$$

$$= 11\text{mV} + 1.44\text{mV} = 12.44\text{mV}$$

APPLICATIONS INFORMATION

As can be seen from the above equation, the biggest portion of the output ripple comes from the ESR of the capacitor. This is why low ESR capacitors are so important in low voltage, high current applications.

PC BOARD LAYOUT CHECKLIST

When laying out the printed circuit board, start with the power devices. Be sure to orient the power circuitry so that a clean flow of the power path is achieved. Conductor widths should be maximized and lengths minimized. After you are satisfied with the power path, the control circuitry should be laid out. It is much easier to find routes for the relatively small traces in the control circuits than it is to find circuitous routes for high current paths. After the layout, the following checklist should be used to ensure proper operation of the LTC3816.

1. Keep the GND and BSOURCE traces separate. The signal ground consists of the LTC3816 GND pin and the (–) terminal of V_{OUT} . The power ground consists of the BSOURCE pin, the Schottky diode anode, the source of the bottom side MOSFET, and the (–) terminal of the input capacitor. Also, try to connect the (–) terminal of the output capacitor as close as possible to the (–) terminals of the input capacitor. Place the LDO ceramic capacitor C_{INTVCC} next to the IC, between $INTV_{CC}$ and GND. The negative terminals of C_{IN} , C_{OUT} and C_{INTVCC} should be as close as possible to one another.
2. The high di/dt loop formed by the top MOSFET, the bottom MOSFET and the C_{IN} capacitor should have short leads and PC trace lengths to minimize high frequency noise and voltage stress from inductive ringing.
3. Connect the drain of the topside MOSFET directly to the (+) plate of C_{IN} , and connect the source of the bottom side MOSFET directly to the (–) terminal of C_{IN} . This capacitor provides the AC current to the MOSFETs.
4. The charge pump capacitor, C_B , should also be next to the IC between BOOST and SW.
5. Place the small-signal components away from high frequency switching nodes (BOOST, SW, TG and BG).
6. The AITC amplifier external components should be placed close to the LTC3816. Only the NTC or PTC thermistor should be placed near the inductor.
7. Are the $V_{CC(SEN)}$ and $V_{SS(SEN)}$, I_{SENP} and I_{SENN} leads routed together with minimum PC trace spacing? The filter capacitor between $V_{CC(SEN)}$ and $V_{SS(SEN)}$ and the filter capacitor between I_{SENP} and I_{SENN} should be as close as possible to the LTC3816. Ensure accurate current sensing with Kelvin connections as shown in Figure 22.
8. To prevent I_{MON} current from affecting the output voltage kelvin sense accuracy, the I_{MON} resistor and $V_{SS(SEN)}$ should be connected to the CPU $V_{SS(SEN)}$ pin using separate PCB traces.
9. Since the IC ground will normally return to the ground planes on the PCB through an array of vias, be sure to avoid having any high di/dt power path currents flowing under the IC.
10. Any external small-signal components that are connected to ground should be located as close as possible to the IC, with local connections to GND or the ground plane using vias.

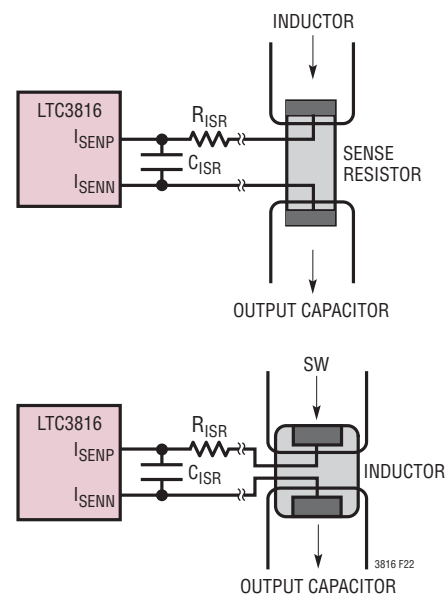
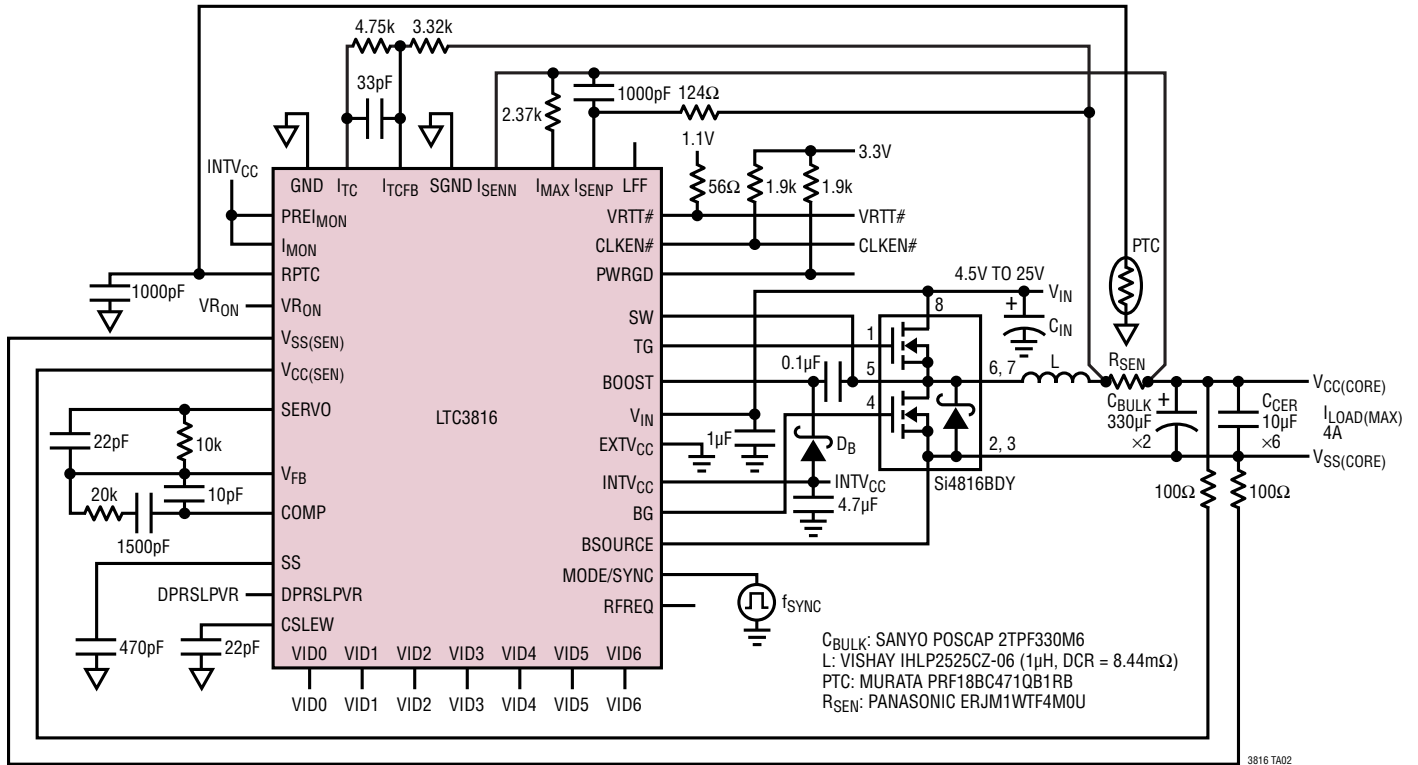

Figure 22. Sense Resistor and Inductor DCR Kelvin Current Sensing

TYPICAL APPLICATIONS

An IMVP-6 Converter Using Current Sense Resistor with -5.7mV/A AVP Slope



Efficiency

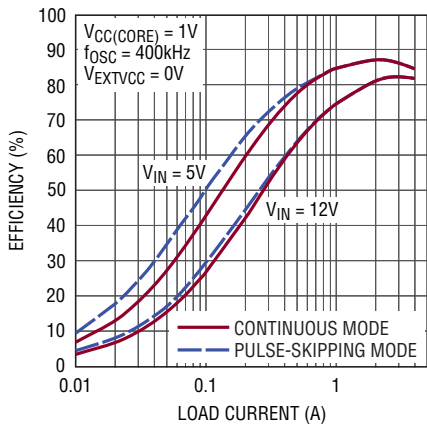

3816 TA02b

Transient Waveform

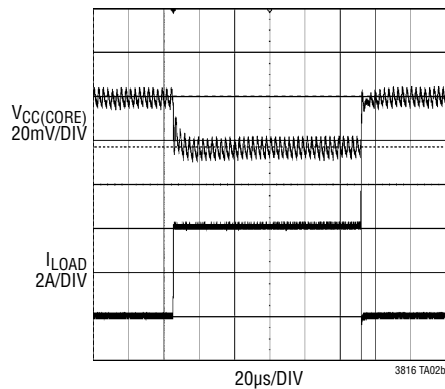

3816 TA02b

TYPICAL APPLICATIONS

A Dual Channel IMVP-6 Converter Using Sense Resistor with -2.1mV/A AVP Slope

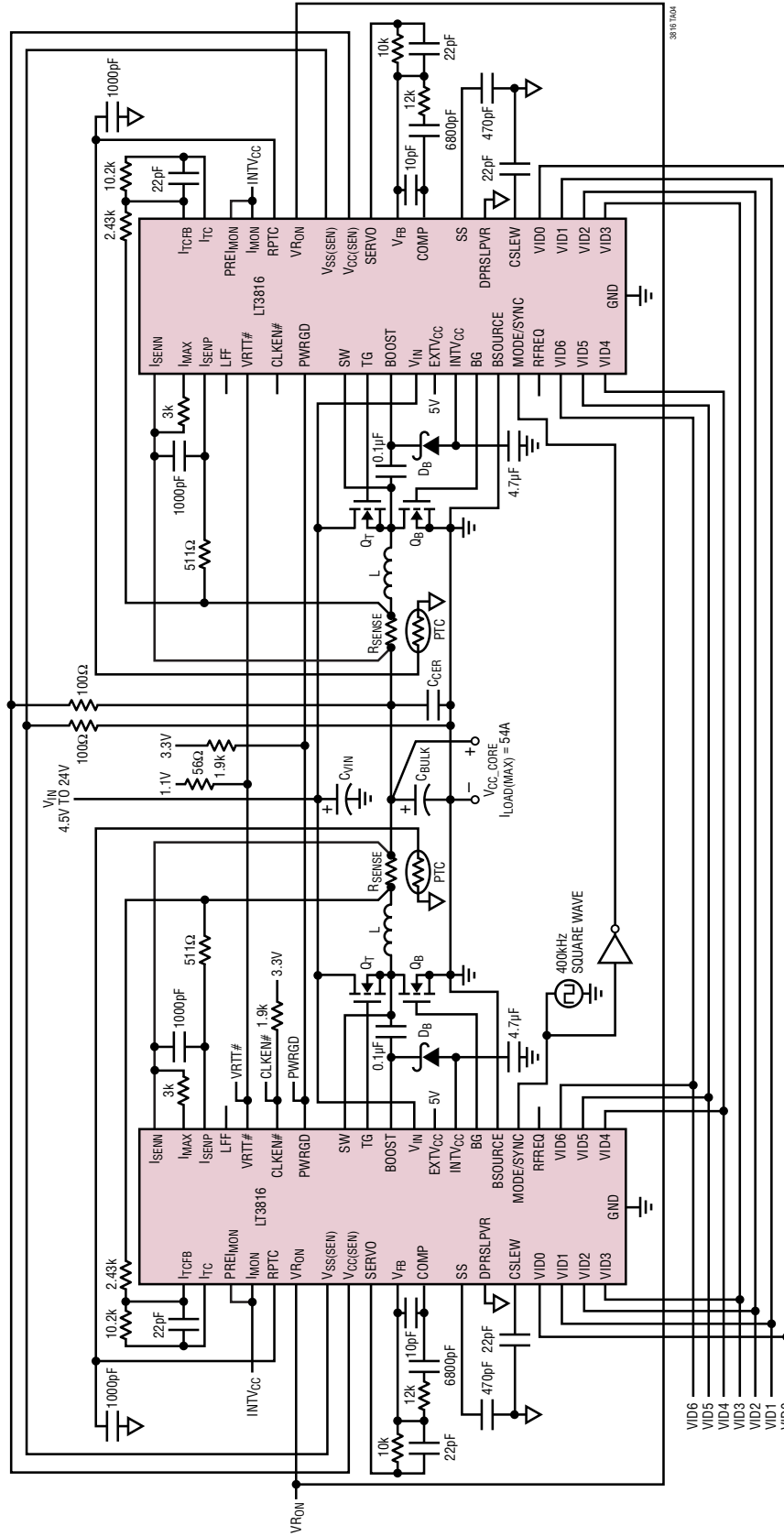

- CapK: 4 × SANYO 2TPF330M6 (330pF)
- Ccf: 32 × 10μF + 2 × 1μF
- Cin: 3 × SANYO OS-CON 35SVPA7M + 2 × 10μF
- D1: CMDSH-4E
- L: IHL-P-5050E-01 (0.33μH, DCR = 1.3mΩ)
- PTC: MURATA PRF186C4710B1RB
- Q1: RENESAS RJK0305DFB
- Qb: 2 × RENESAS RJK0330DPB
- RSense: PANASONIC ERJM1VTF1M0U (1mΩ)

PACKAGE DESCRIPTION

FE Package
38-Lead Plastic eTSSOP (4.4mm)
 (Reference LTC DWG # 05-08-1772 Rev B)
Exposed Pad Variation AA

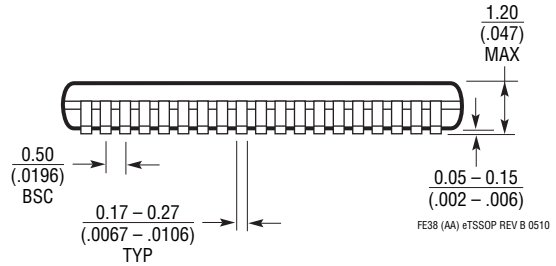
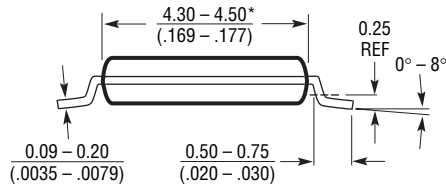
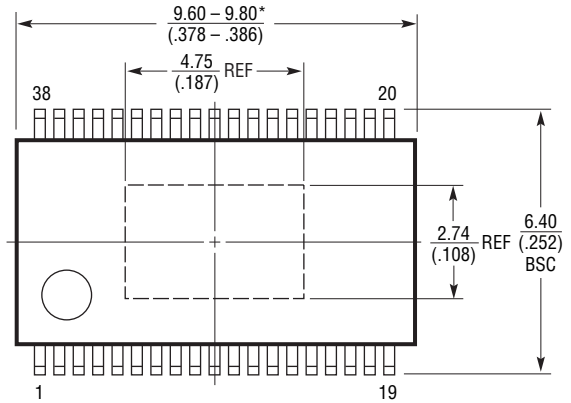
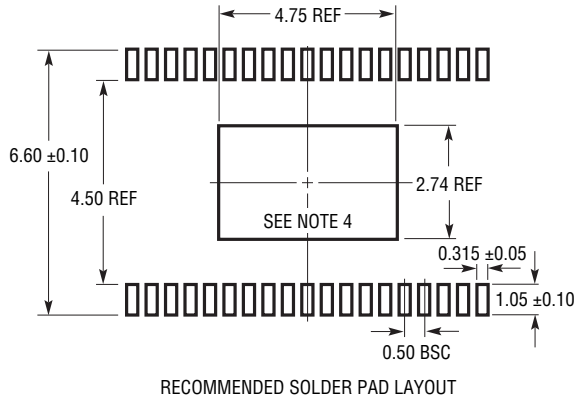

- NOTE:
1. CONTROLLING DIMENSION: MILLIMETERS
 2. DIMENSIONS ARE IN MILLIMETERS (INCHES)
 3. DRAWING NOT TO SCALE
 4. RECOMMENDED MINIMUM PCB METAL SIZE FOR EXPOSED PAD ATTACHMENT
- *DIMENSIONS DO NOT INCLUDE MOLD FLASH. MOLD FLASH SHALL NOT EXCEED 0.150mm (.006") PER SIDE

TYPICAL APPLICATION

An IMVP-6.5 Converter Using Temperature Compensated Inductor DCR Sensing with -3mV/A AVP Slope

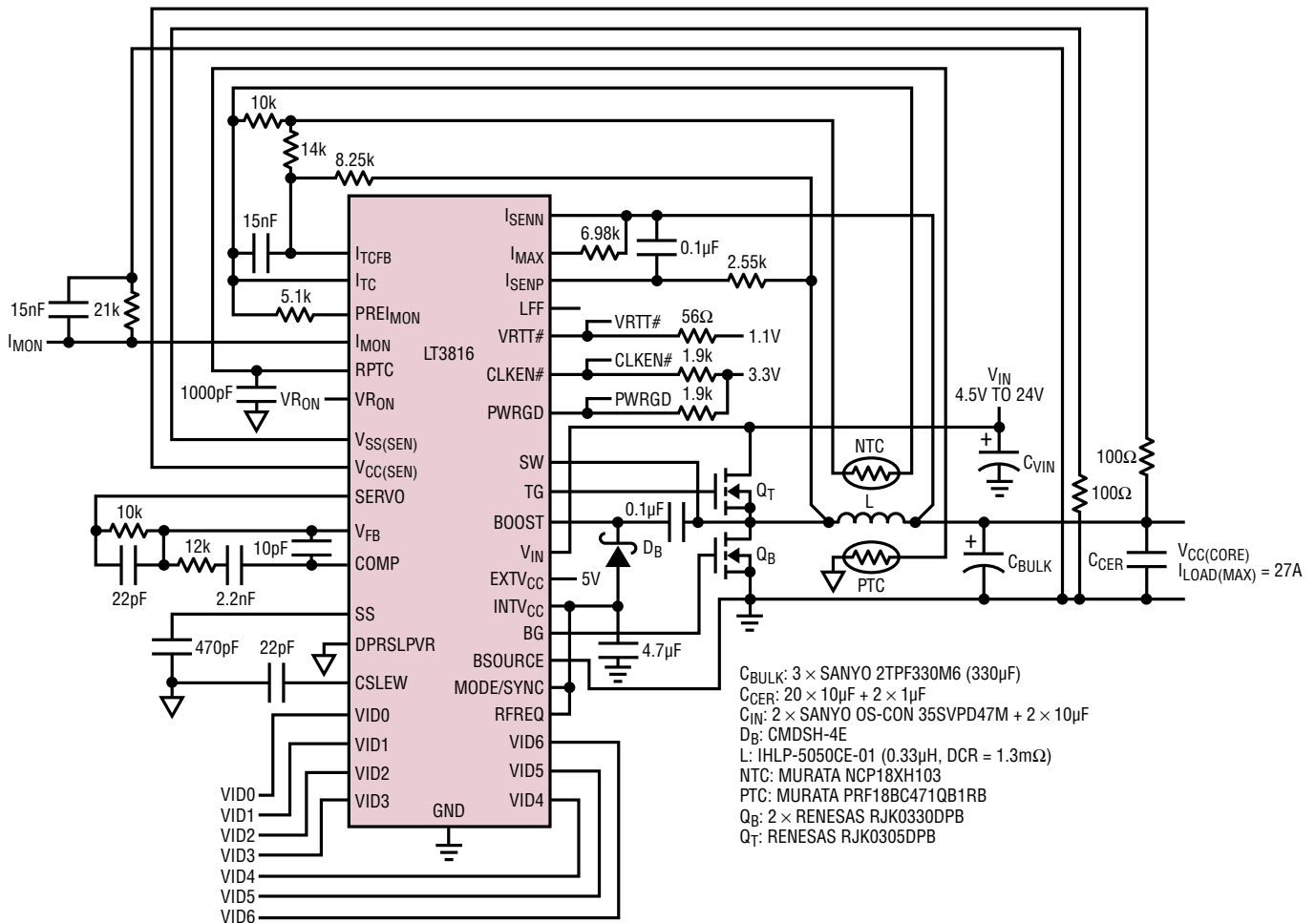

RELATED PARTS

PART NUMBER	DESCRIPTION	COMMENTS
LTC3732	3-Phase, 5-Bit VID, 600kHz Synchronous Buck Switching Regulator Controller	VRM9.0 and VRM9.1, VID = 1.1V to 1.85V
LTC3733	3-Phase, 5-Bit VID, 600kHz Synchronous Buck Switching Regulator Controller	AMD Opteron (VID = 0.8V to 1.55V)
LTC3734	Single-Phase, High Efficiency DC/DC Controller for Intel Mobile CPUs	6-Bit IMVP-4 VID: $0.7\text{V} \leq V_{\text{OUT}} \leq 1.708\text{V}$, $I_{\text{LOAD}} \leq 25\text{A}$, Lossless Voltage Positioning
LTC3735	2-Phase, High Efficiency DC/DC Controller for Intel Mobile CPUs	6-Bit IMVP-IV, VID Code: $V_{\text{OUT}} = 0.7\text{V}$ to 1.708V
LTC3738	3-Phase Buck Controller for Intel VRM9/VRM10 with Active Voltage Positioning	VID = 1.1V to 1.85V
LTC3819	2-Phase, High Efficiency, Step-Down Controller for AMD CPUs	$4\text{V} \leq V_{\text{IN}} \leq 36\text{V}$, VID = 1.025V to 1.4125V
LTC3850	Dual 2-Phase Synchronous Controller	Dual 180° Phase Controllers, $4\text{V} \leq V_{\text{IN}} \leq 28\text{V}$, 97% Duty Cycle
LTC3851A	No R _{SENSE} ™ Wide Input Range Step-Down Controller	$4\text{V} \leq V_{\text{IN}} \leq 38\text{V}$, Very Low Dropout with Tracking
LTC3853	Triple Output, Multiphase Synchronous Step-Down Controller	Triple Phase Version of LTC3850 in a 40-Lead 6mm x 6mm QFN Package

Looking for pricing, stock, or lifecycle information?

Click below to explore more details on WIN SOURCE:

 [View LTC3816IUHF#PBF on WIN SOURCE](#)

 [Analog Devices Inc. Information](#)

Optimize Your Supply Chain with WIN SOURCE Solutions

-  Global Sourcing Solution
-  Obsolete Management
-  Cost Control Management
-  Shortage Management
-  Alternative Solution
-  Excess Inventory Management