



**THE DATASHEET OF
LTC2336HMS-18#PBF**



18-Bit, 250ksps, $\pm 10.24V$ True Bipolar, Fully Differential Input ADC with 100dB SNR

FEATURES

- 250ksps Throughput Rate
- ± 4 LSB INL (Max)
- Guaranteed 18-Bit No Missing Codes
- Fully Differential Inputs
- True Bipolar Input Ranges $\pm 6.25V$, $\pm 10.24V$, $\pm 12.5V$
- 100dB SNR (Typ) at $f_{IN} = 2kHz$
- $-115dB$ THD (Typ) at $f_{IN} = 2kHz$
- Guaranteed Operation to 125°C
- Single 5V Supply
- Low Drift (20ppm/°C Max) 2.048V Internal Reference
- Onboard Single-Shot Capable Reference Buffer
- No Pipeline Delay, No Cycle Latency
- 1.8V to 5V I/O Voltages
- SPI-Compatible Serial I/O with Daisy-Chain Mode
- Internal Conversion Clock
- Power Dissipation 28mW (Typ)
- 16-Lead MSOP Package

APPLICATIONS

- Programmable Logic Controllers
- Industrial Process Control
- High Speed Data Acquisition
- Portable or Compact Instrumentation
- ATE

DESCRIPTION

The **LTC[®]2336-18** is a low noise, high speed 18-bit successive approximation register (SAR) ADC with fully differential inputs. Operating from a single 5V supply, the LTC2336-18 has a $\pm 10.24V$ true bipolar input range, making it ideal for high voltage applications which require a wide dynamic range. The LTC2336-18 achieves ± 4 LSB INL maximum, no missing codes at 18-bits with 100dB SNR.

The LTC2336-18 has an onboard single-shot capable reference buffer and low drift (20ppm/°C max) 2.048V temperature compensated reference. The LTC2336-18 also has a high speed SPI-compatible serial interface that supports 1.8V, 2.5V, 3.3V and 5V logic while also featuring a daisy-chain mode. The fast 250ksps throughput with no cycle latency makes the LTC2336-18 ideally suited for a wide variety of high speed applications. An internal oscillator sets the conversion time, easing external timing considerations. The LTC2336-18 dissipates only 28mW and automatically naps between conversions, leading to reduced power dissipation that scales with the sampling rate. A sleep mode is also provided to reduce the power consumption of the LTC2336-18 to 300 μ W for further power savings during inactive periods.

LT, LT, LTC, LTM, Linear Technology and the Linear logo are registered trademarks and SoftSpan is a trademark of Linear Technology Corporation. All other trademarks are the property of their respective owners. Protected by U.S. Patents, including 7705765 and 7961132

TYPICAL APPLICATION

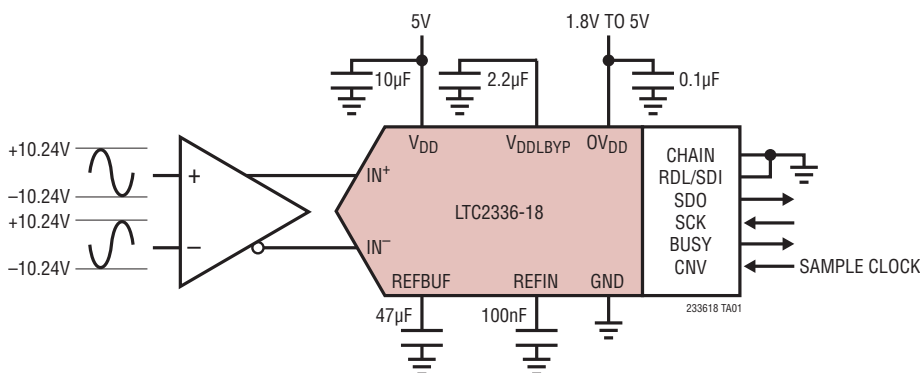

32k Point FFT $f_s = 250ksps$,
 $f_{IN} = 2kHz$

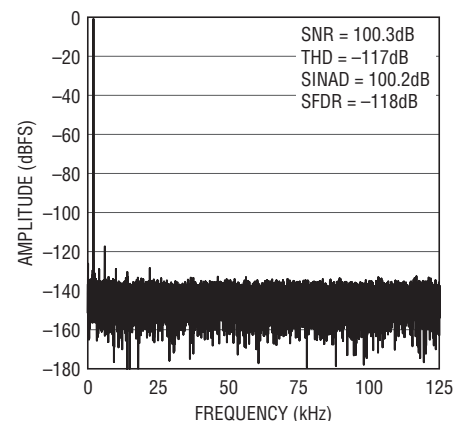

233618 TA01b
233618fa

LTC2336-18

ABSOLUTE MAXIMUM RATINGS

(Notes 1, 2)

Supply Voltage (V_{DD})	6V
Supply Voltage (OV_{DD})	6V
Supply Bypass Voltage ($V_{DDLBYYP}$)	3.2V
Analog Input Voltage	
IN^+ , IN^-	-16.5V to 16.5V
REFBUF	6V
REFIN	2.8V
Digital Input Voltage	
(Note 3)	(GND -0.3V) to (OV_{DD} + 0.3V)
Digital Output Voltage	
(Note 3)	(GND -0.3V) to (OV_{DD} + 0.3V)
Power Dissipation	500mW
Operating Temperature Range	
LTC2336C	0°C to 70°C
LTC2336I	-40°C to 85°C
LTC2336H	-40°C to 125°C
Storage Temperature Range	-65°C to 150°C

PIN CONFIGURATION

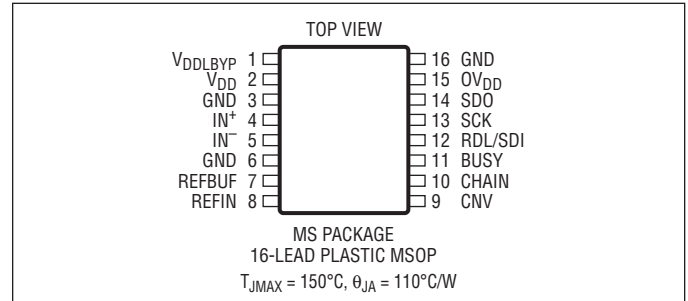

ORDER INFORMATION

<http://www.linear.com/product/LTC2336-18#orderinfo>

LEAD FREE FINISH	TAPE AND REEL	PART MARKING*	PACKAGE DESCRIPTION	TEMPERATURE RANGE
LTC2336CMS-18#PBF	LTC2336CMS-18#TRPBF	233618	16-Lead Plastic MSOP	0°C to 70°C
LTC2336IMS-18#PBF	LTC2336IMS-18#TRPBF	233618	16-Lead Plastic MSOP	-40°C to 85°C
LTC2336HMS-18#PBF	LTC2336HMS-18#TRPBF	233618	16-Lead Plastic MSOP	-40°C to 125°C

Consult LTC Marketing for parts specified with wider operating temperature ranges. *The temperature grade is identified by a label on the shipping container. For more information on lead free part marking, go to: <http://www.linear.com/leadfree/>. For more information on tape and reel specifications, go to: <http://www.linear.com/tapeandree/>. Some packages are available in 500 unit reels through designated sales channels with #TRMPBF suffix.

ELECTRICAL CHARACTERISTICS

The ● denotes the specifications which apply over the full operating temperature range, otherwise specifications are at $T_A = 25^\circ\text{C}$. (Note 4)

SYMBOL	PARAMETER	CONDITIONS	MIN	TYP	MAX	UNITS
V_{IN}^+	Absolute Input Range (IN^+)	(Note 5) ●	$-2.5 \cdot V_{REFBUF} - 0.25$		$2.5 \cdot V_{REFBUF} + 0.25$	V
V_{IN}^-	Absolute Input Range (IN^-)	(Note 5) ●	$-2.5 \cdot V_{REFBUF} - 0.25$		$2.5 \cdot V_{REFBUF} + 0.25$	V
$V_{IN}^+ - V_{IN}^-$	Input Differential Voltage Range	$V_{IN} = V_{IN}^+ - V_{IN}^-$ ●	$-5 \cdot V_{REFBUF}$		$5 \cdot V_{REFBUF}$	V
V_{CM}	Common Mode Input Range	(Note 11) ●	-0.5	0	0.5	V
I_{IN}	Analog Input Current	●	-7.8		4.8	mA
C_{IN}	Analog Input Capacitance			5		pF
R_{IN}	Analog Input Resistance			2.083		k Ω
CMRR	Input Common Mode Rejection Ratio	$f_{IN} = 125\text{kHz}$		67		dB

CONVERTER CHARACTERISTICS

The ● denotes the specifications which apply over the full operating temperature range, otherwise specifications are at $T_A = 25^\circ\text{C}$. (Note 4)

SYMBOL	PARAMETER	CONDITIONS	MIN	TYP	MAX	UNITS
	Resolution	●	18			Bits
	No Missing Codes	●	18			Bits
	Transition Noise			0.8		LSB _{RMS}
INL	Integral Linearity Error	(Note 6) ●	-4	± 1	4	LSB
DNL	Differential Linearity Error	●	-1	± 0.1	1	LSB
BZE	Bipolar Zero-Scale Error	(Note 7) ●	-15	0	15	LSB
	Bipolar Zero-Scale Error Drift			0.01		LSB/ $^\circ\text{C}$
FSE	Bipolar Full-Scale Error	$V_{REFBUF} = 4.096\text{V}$ (REFBUF Overdriven) (Notes 7, 9) ●	-100		100	LSB
		$REFIN = 2.048\text{V}$ (Note 7) ●	-150		150	LSB
	Bipolar Full-Scale Error Drift			± 0.5		ppm/ $^\circ\text{C}$

DYNAMIC ACCURACY

The ● denotes the specifications which apply over the full operating temperature range, otherwise specifications are at $T_A = 25^\circ\text{C}$ and $A_{IN} = -1\text{dBFS}$. (Notes 4, 8)

SYMBOL	PARAMETER	CONDITIONS	MIN	TYP	MAX	UNITS
SINAD	Signal-to-(Noise + Distortion) Ratio	$\pm 6.25\text{V}$ Range, $f_{IN} = 2\text{kHz}$, $REFIN = 1.25\text{V}$ ●	93	97		dB
		$\pm 10.24\text{V}$ Range, $f_{IN} = 2\text{kHz}$, $REFIN = 2.048\text{V}$ ●	95	100		dB
		$\pm 12.5\text{V}$ Range, $f_{IN} = 2\text{kHz}$, $REFBUF = 5\text{V}$ ●	96	101		dB
SNR	Signal-to-Noise Ratio	$\pm 6.25\text{V}$ Range, $f_{IN} = 2\text{kHz}$, $REFIN = 1.25\text{V}$ ●	93.5	97		dB
		$\pm 10.24\text{V}$ Range, $f_{IN} = 2\text{kHz}$, $REFIN = 2.048\text{V}$ ●	96	100		dB
		$\pm 12.5\text{V}$ Range, $f_{IN} = 2\text{kHz}$, $REFBUF = 5\text{V}$ ●	98	102		dB
THD	Total Harmonic Distortion	$\pm 6.25\text{V}$ Range, $f_{IN} = 2\text{kHz}$, $REFIN = 1.25\text{V}$ ●		-111	-102	dB
		$\pm 10.24\text{V}$ Range, $f_{IN} = 2\text{kHz}$, $REFIN = 2.048\text{V}$ ●		-115	-102	dB
		$\pm 12.5\text{V}$ Range, $f_{IN} = 2\text{kHz}$, $REFBUF = 5\text{V}$ ●		-112	-100	dB
SFDR	Spurious Free Dynamic Range	$\pm 6.25\text{V}$ Range, $f_{IN} = 2\text{kHz}$, $REFIN = 1.25\text{V}$ ●	102	113		dB
		$\pm 10.24\text{V}$ Range, $f_{IN} = 2\text{kHz}$, $REFIN = 2.048\text{V}$ ●	102	117		dB
		$\pm 12.5\text{V}$ Range, $f_{IN} = 2\text{kHz}$, $REFBUF = 5\text{V}$ ●	100	114		dB
	-3dB Input Linear Bandwidth			7		MHz
	Aperture Delay			500		ps
	Aperture Jitter			4		ps
	Transient Response	Full-Scale Step		1		μs

233618fa

INTERNAL REFERENCE CHARACTERISTICS

The ● denotes the specifications which apply over the full operating temperature range, otherwise specifications are at $T_A = 25^\circ\text{C}$. (Note 4)

SYMBOL	PARAMETER	CONDITIONS	MIN	TYP	MAX	UNITS
V_{REFIN}	Internal Reference Output Voltage		2.043	2.048	2.053	V
	V_{REFIN} Temperature Coefficient	(Note 14)	●	2	20	ppm/ $^\circ\text{C}$
	REFIN Output Impedance			15		$\text{k}\Omega$
	V_{REFIN} Line Regulation	$V_{\text{DD}} = 4.75\text{V}$ to 5.25V		0.08		mV/V
	REFIN Input Voltage Range	(REFIN Overdriven) (Note 5)	1.25		2.4	V

REFERENCE BUFFER CHARACTERISTICS

The ● denotes the specifications which apply over the full operating temperature range, otherwise specifications are at $T_A = 25^\circ\text{C}$. (Note 4)

SYMBOL	PARAMETER	CONDITIONS	MIN	TYP	MAX	UNITS	
V_{REFBUF}	Reference Buffer Output Voltage	$V_{\text{REFIN}} = 2.048\text{V}$	●	4.091	4.096	4.101	V
	REFBUF Input Voltage Range	(REFBUF Overdriven) (Notes 5, 9)	●	2.5	5	V	
	REFBUF Output Impedance	$V_{\text{REFIN}} = 0\text{V}$		13		$\text{k}\Omega$	
I_{REFBUF}	REFBUF Load Current	$V_{\text{REFBUF}} = 5\text{V}$ (REFBUF Overdriven) (Notes 9, 10) $V_{\text{REFBUF}} = 5\text{V}$, Nap Mode (REFBUF Overdriven) (Note 9)	●	0.56	0.6	mA	
				0.39		mA	

DIGITAL INPUTS AND DIGITAL OUTPUTS

The ● denotes the specifications which apply over the full operating temperature range, otherwise specifications are at $T_A = 25^\circ\text{C}$. (Note 4)

SYMBOL	PARAMETER	CONDITIONS	MIN	TYP	MAX	UNITS
V_{IH}	High Level Input Voltage		●	$0.8 \cdot OV_{\text{DD}}$		V
V_{IL}	Low Level Input Voltage		●		$0.2 \cdot OV_{\text{DD}}$	V
I_{IN}	Digital Input Current	$V_{\text{IN}} = 0\text{V}$ to OV_{DD}	●	-10	10	μA
C_{IN}	Digital Input Capacitance			5		pF
V_{OH}	High Level Output Voltage	$I_{\text{O}} = -500\mu\text{A}$	●	$OV_{\text{DD}} - 0.2$		V
V_{OL}	Low Level Output Voltage	$I_{\text{O}} = 500\mu\text{A}$	●		0.2	V
I_{OZ}	Hi-Z Output Leakage Current	$V_{\text{OUT}} = 0\text{V}$ to OV_{DD}	●	-10	10	μA
I_{SOURCE}	Output Source Current	$V_{\text{OUT}} = 0\text{V}$		-10		mA
I_{SINK}	Output Sink Current	$V_{\text{OUT}} = OV_{\text{DD}}$		10		mA

POWER REQUIREMENTS

The ● denotes the specifications which apply over the full operating temperature range, otherwise specifications are at $T_A = 25^\circ\text{C}$. (Note 4)

SYMBOL	PARAMETER	CONDITIONS	MIN	TYP	MAX	UNITS	
V_{DD}	Supply Voltage		●	4.75	5	5.25	V
OV_{DD}	Supply Voltage		●	1.71		5.25	V
I_{VDD}	Supply Current	250ksps Sample Rate ($I_{\text{N}^+} = I_{\text{N}^-} = 0\text{V}$)	●	5.5	6.5	mA	
I_{OVDD}	Supply Current	250ksps Sample Rate ($C_{\text{L}} = 20\text{pF}$)		0.05		mA	
I_{NAP}	Nap Mode Current	Conversion Done ($I_{\text{VDD}} + I_{\text{OVDD}}$)	●	3.9	4.6	mA	
I_{SLEEP}	Sleep Mode Current	Sleep Mode ($I_{\text{VDD}} + I_{\text{OVDD}}$)	●	60	225	μA	
P_{D}	Power Dissipation	250ksps Sample Rate ($I_{\text{N}^+} = I_{\text{N}^-} = 0\text{V}$)	●	27.5	32.5	mW	
	Nap Mode	Conversion Done ($I_{\text{VDD}} + I_{\text{OVDD}}$)	●	19.5	23	mW	
	Sleep Mode	Sleep Mode ($I_{\text{VDD}} + I_{\text{OVDD}}$)	●	0.3	1.1	mW	

ADC TIMING CHARACTERISTICS The ● denotes the specifications which apply over the full operating temperature range, otherwise specifications are at $T_A = 25^\circ\text{C}$. (Note 4)

SYMBOL	PARAMETER	CONDITIONS	MIN	TYP	MAX	UNITS
f_{SMPL}	Maximum Sampling Frequency		●		250	ksps
t_{CONV}	Conversion Time		●	1.9	3	μs
t_{ACQ}	Acquisition Time	$t_{\text{ACQ}} = t_{\text{CYC}} - t_{\text{HOLD}}$ (Note 11)	●	3.460		μs
t_{HOLD}	Maximum Time between Acquisitions		●		540	ns
t_{CYC}	Time Between Conversions		●	4		μs
t_{CNVH}	CNV High Time		●	20		ns
t_{BUSYLH}	CNV \uparrow to BUSY Delay	$C_L = 20\text{pF}$	●		13	ns
t_{CNVL}	Minimum Low Time for CNV	(Note 12)	●	20		ns
t_{QUIET}	SCK Quiet Time from CNV \uparrow	(Note 11)	●	20		ns
t_{SCK}	SCK Period	(Notes 12, 13)	●	10		ns
t_{SCKH}	SCK High Time		●	4		ns
t_{SCKL}	SCK Low Time		●	4		ns
t_{SSDISCK}	SDI Setup Time From SCK \uparrow	(Note 12)	●	4		ns
t_{HSDISCK}	SDI Hold Time From SCK \uparrow	(Note 12)	●	1		ns
t_{SCKCH}	SCK Period in Chain Mode	$t_{\text{SCKCH}} = t_{\text{SSDISCK}} + t_{\text{DSDO}}$ (Note 12)	●	13.5		ns
t_{DSDO}	SDO Data Valid Delay from SCK \uparrow	$C_L = 20\text{pF}, OV_{\text{DD}} = 5.25\text{V}$ $C_L = 20\text{pF}, OV_{\text{DD}} = 2.5\text{V}$ $C_L = 20\text{pF}, OV_{\text{DD}} = 1.71\text{V}$	●		7.5	ns
			●		8	ns
			●		9.5	ns
t_{HSDO}	SDO Data Remains Valid Delay from SCK \uparrow	$C_L = 20\text{pF}$ (Note 11)	●	1		ns
$t_{\text{DSDO} \text{BUSYL}}$	SDO Data Valid Delay from BUSY \downarrow	$C_L = 20\text{pF}$ (Note 11)	●		5	ns
t_{EN}	Bus Enable Time After RDL \downarrow	(Note 12)	●		16	ns
t_{DIS}	Bus Relinquish Time After RDL \uparrow	(Note 12)	●		13	ns
t_{WAKE}	REFBUF Wakeup Time	$C_{\text{REFBUF}} = 47\mu\text{F}, C_{\text{REFIN}} = 100\text{nF}$		200		ms

Note 1: Stresses beyond those listed under Absolute Maximum Ratings may cause permanent damage to the device. Exposure to any Absolute Maximum Rating condition for extended periods may affect device reliability and lifetime.

Note 2: All voltage values are with respect to ground.

Note 3: When these pin voltages are taken below ground or above V_{DD} or OV_{DD} , they will be clamped by internal diodes. This product can handle input currents up to 100mA below ground or above V_{DD} or OV_{DD} without latch-up.

Note 4: $V_{\text{DD}} = 5\text{V}$, $OV_{\text{DD}} = 2.5\text{V}$, $\pm 10.24\text{V}$ Range, $\text{REFIN} = 2.048\text{V}$, $f_{\text{SMPL}} = 250\text{kHz}$.

Note 5: Recommended operating conditions.

Note 6: Integral nonlinearity is defined as the deviation of a code from a straight line passing through the actual endpoints of the transfer curve. The deviation is measured from the center of the quantization band.

Note 7: Bipolar zero error is the offset voltage measured from -0.5LSB when the output code flickers between 00 0000 0000 0000 and 11 1111 1111 1111. Full-scale bipolar error is the worst-case of $-FS$ or $+FS$ untrimmed deviation from ideal first and last code transitions and includes the effect of offset error.

Note 8: All specifications in dB are referred to a full-scale $\pm 20.48\text{V}$ input with $\text{REFIN} = 2.048\text{V}$.

Note 9: When REFBUF is overdriven, the internal reference buffer must be turned off by setting $\text{REFIN} = 0\text{V}$.

Note 10: $f_{\text{SMPL}} = 250\text{kHz}$, I_{REFBUF} varies proportionally with sample rate.

Note 11: Guaranteed by design, not subject to test.

Note 12: Parameter tested and guaranteed at $OV_{\text{DD}} = 1.71\text{V}$, $OV_{\text{DD}} = 2.5\text{V}$ and $OV_{\text{DD}} = 5.25\text{V}$.

Note 13: t_{SCK} of 10ns maximum allows a shift clock frequency up to 100MHz for rising edge capture.

Note 14: Temperature coefficient is calculated by dividing the maximum change in output voltage by the specified temperature range.

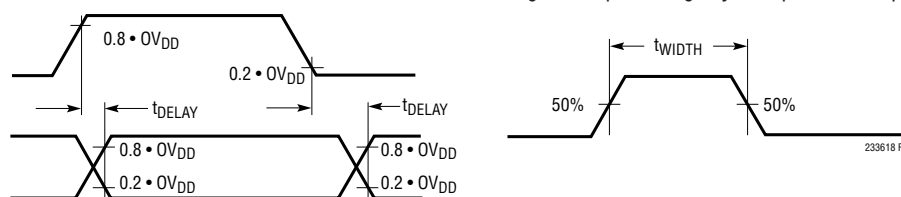
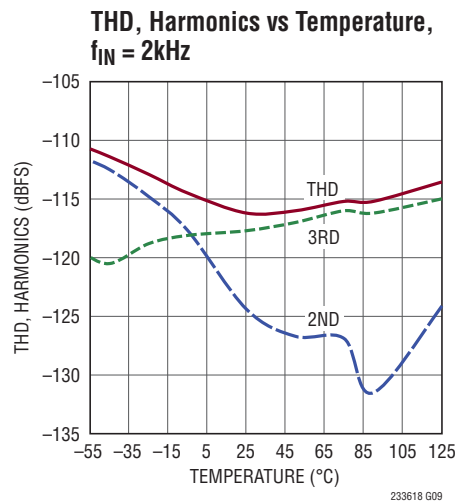
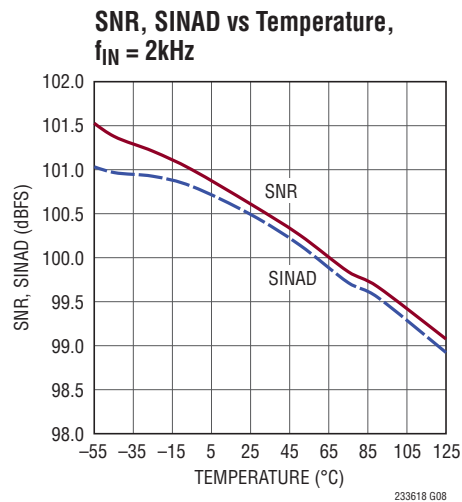
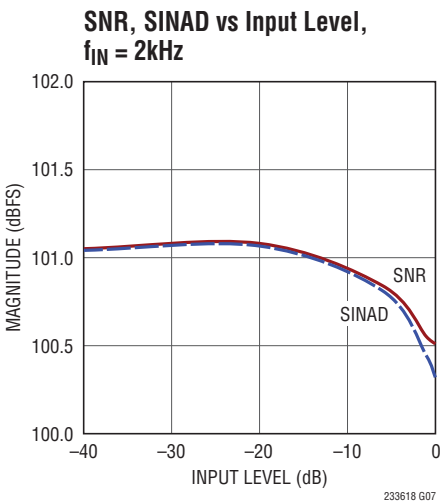
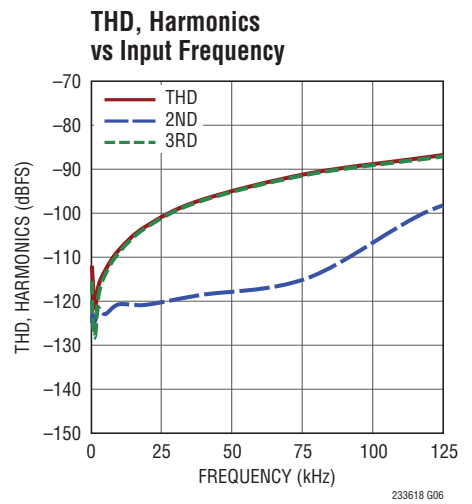
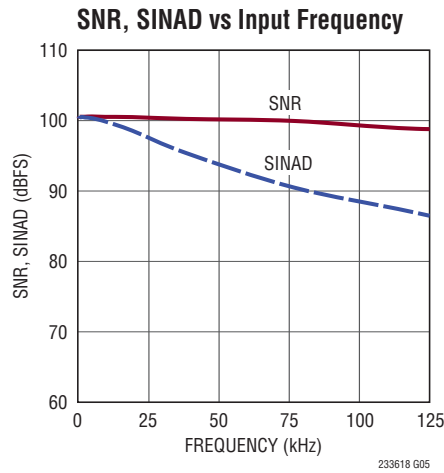
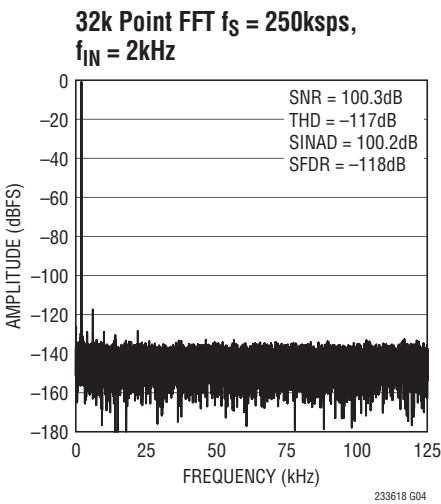
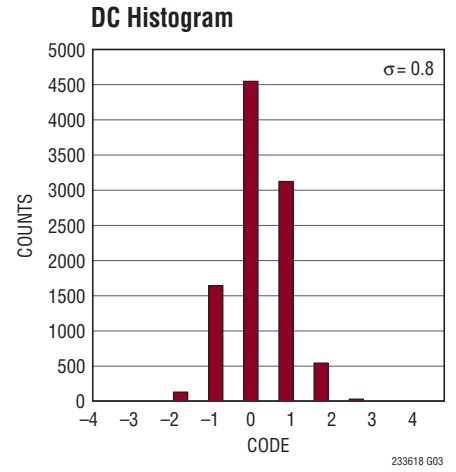
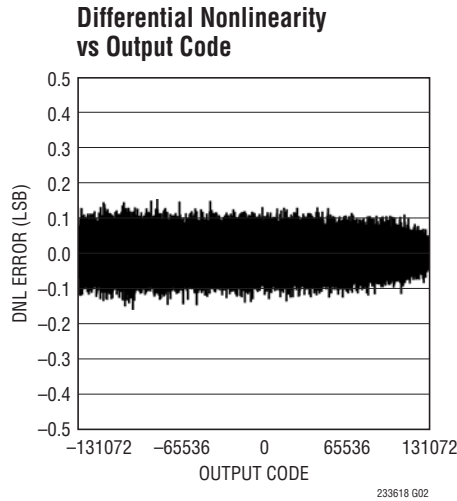
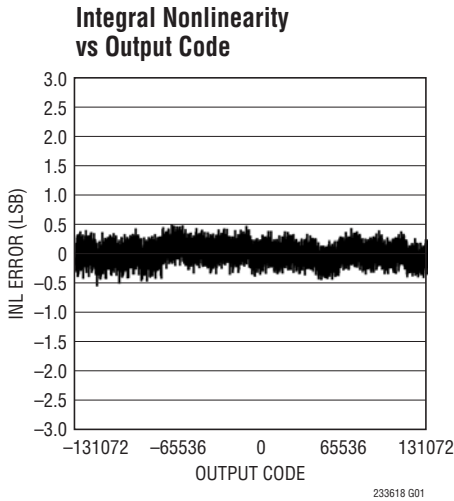
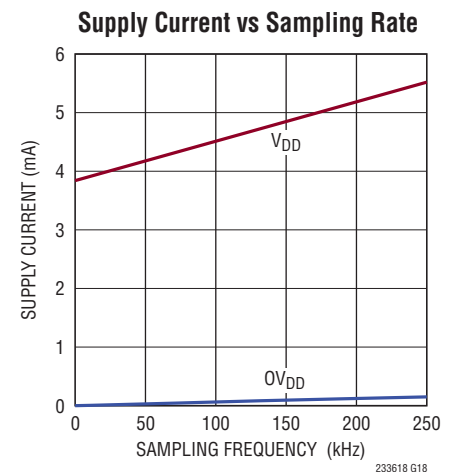
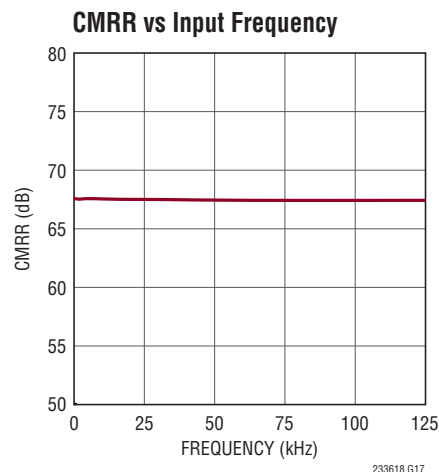
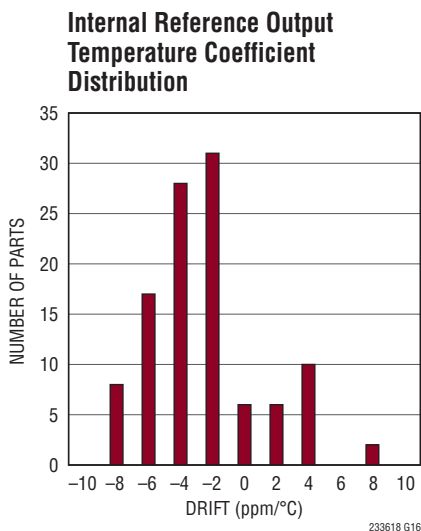
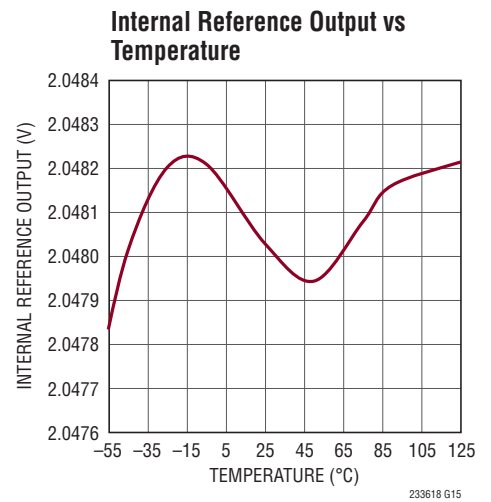
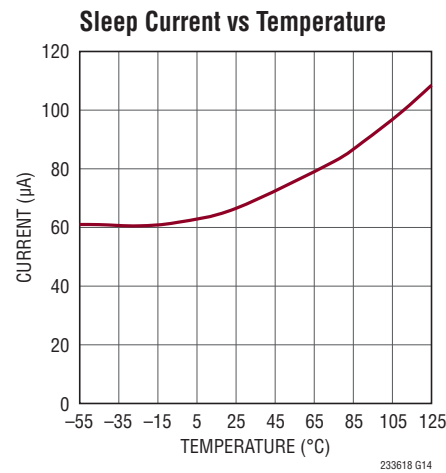
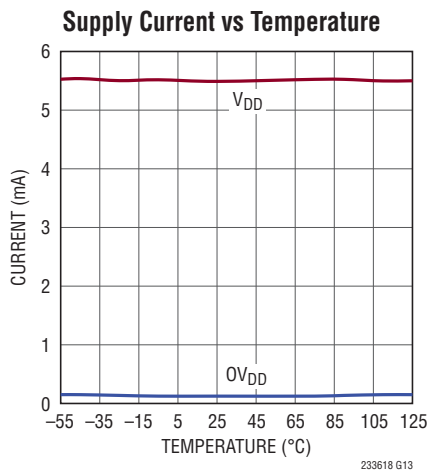
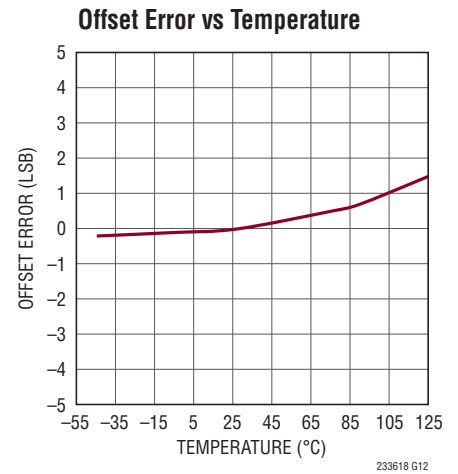
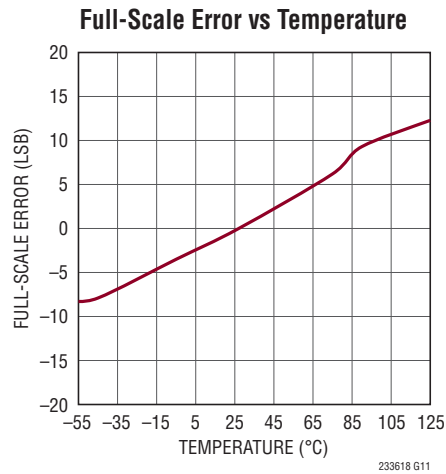
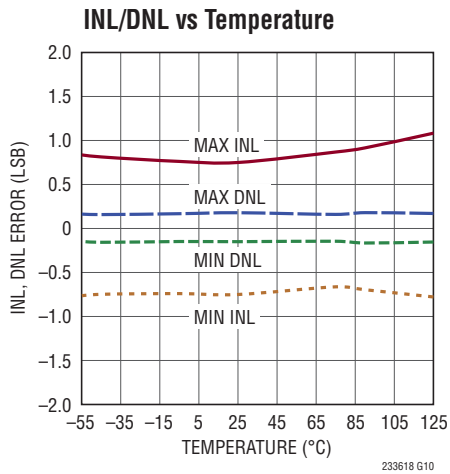

Figure 1. Voltage Levels for Timing Specifications

TYPICAL PERFORMANCE CHARACTERISTICS $T_A = 25^\circ\text{C}$, $V_{DD} = 5\text{V}$, $OV_{DD} = 2.5\text{V}$, $REF_{IN} = 2.048\text{V}$, $f_{SAMPL} = 250\text{ksps}$, unless otherwise noted.



TYPICAL PERFORMANCE CHARACTERISTICS $T_A = 25^\circ\text{C}$, $V_{DD} = 5\text{V}$, $OV_{DD} = 2.5\text{V}$, $REF_{IN} = 2.048\text{V}$, $f_{SAMPL} = 250\text{ksps}$, unless otherwise noted.



PIN FUNCTIONS

V_{DDL}BYP (Pin 1): 2.5V Supply Bypass Pin. The voltage on this pin is generated via an onboard regulator off of V_{DD}. This pin must be bypassed with a 2.2μF ceramic capacitor to GND.

V_{DD} (Pin 2): 5V Power Supply. The range of V_{DD} is 4.75V to 5.25V. Bypass V_{DD} to GND with a 10μF ceramic capacitor.

GND (Pins 3, 6 and 16): Ground.

IN⁺, IN⁻ (Pins 4, 5): Positive and Negative Differential Analog Inputs. Typical input range ±10.24V.

REFBUF (Pin 7): Reference Buffer Output. An onboard buffer nominally outputs 4.096V to this pin. This pin is referred to GND and should be decoupled closely to the pin with a 47μF ceramic capacitor. The internal buffer driving this pin may be disabled by grounding its input at REFIN. Once the buffer is disabled, an external reference may overdrive this pin in the range of 2.5V to 5V. A resistive load greater than 500kΩ can be placed on the reference buffer output.

REFIN (Pin 8): Reference Output/Reference Buffer Input. An onboard bandgap reference nominally outputs 2.048V at this pin. Bypass this pin with a 100nF ceramic capacitor to GND to limit the reference output noise. If more accuracy is desired, this pin may be overdriven by an external reference in the range of 1.25V to 2.4V.

CNV (Pin 9): Convert Input. A rising edge on this input powers up the part and initiates a new conversion. Logic levels are determined by OV_{DD}.

CHAIN (Pin 10): Chain Mode Selector Pin. When low, the LTC2336-18 operates in normal mode and the RDL/SDI input pin functions to enable or disable SDO. When high, the LTC2336-18 operates in chain mode and the RDL/SDI pin functions as SDI, the daisy-chain serial data input. Logic levels are determined by OV_{DD}.

BUSY (Pin 11): BUSY Indicator. Goes high at the start of a new conversion and returns low when the conversion has finished. Logic levels are determined by OV_{DD}.

RDL/SDI (Pin 12): When CHAIN is low, the part is in normal mode and the pin is treated as a bus enabling input. When CHAIN is high, the part is in chain mode and the pin is treated as a serial data input pin where data from another ADC in the daisy chain is input. Logic levels are determined by OV_{DD}.

SCK (Pin 13): Serial Data Clock Input. When SDO is enabled, the conversion result or daisy-chain data from another ADC is shifted out on the rising edges of this clock MSB first. Logic levels are determined by OV_{DD}.

SDO (Pin 14): Serial Data Output. The conversion result or daisy-chain data is output on this pin on each rising edge of SCK MSB first. The output data is in 2's complement format. Logic levels are determined by OV_{DD}.

OV_{DD} (Pin 15): I/O Interface Digital Power. The range of OV_{DD} is 1.71V to 5.25V. This supply is nominally set to the same supply as the host interface (1.8V, 2.5V, 3.3V, or 5V). Bypass OV_{DD} to GND with a 0.1μF capacitor.

FUNCTIONAL BLOCK DIAGRAM

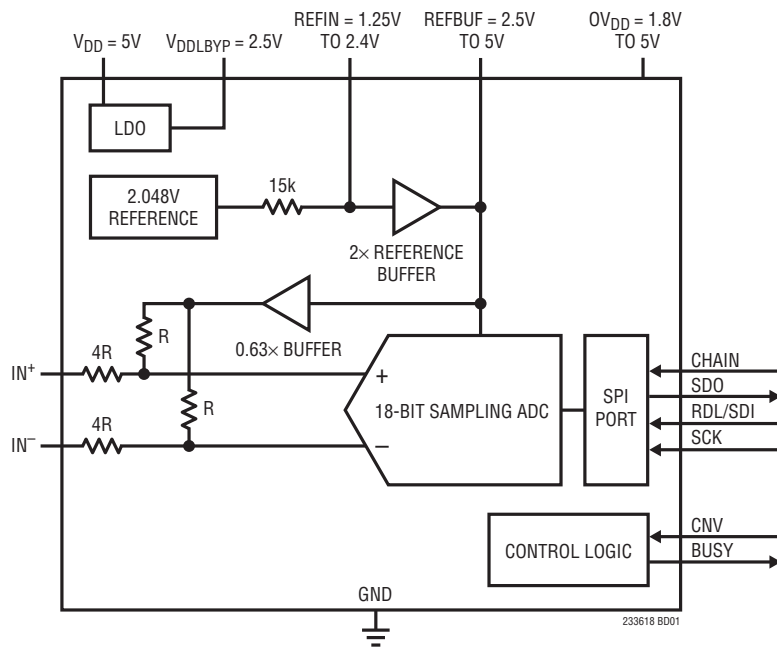

TIMING DIAGRAM

Conversion Timing Using the Serial Interface

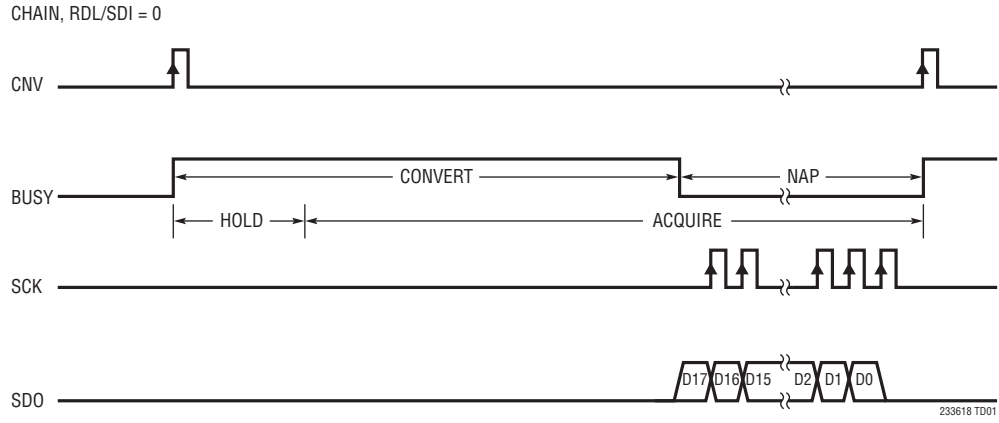

APPLICATIONS INFORMATION

OVERVIEW

The LTC2336-18 is a low noise, high speed 18-bit successive approximation register (SAR) ADC with fully differential inputs. Operating from a single 5V supply, the LTC2336-18 has a $\pm 10.24V$ true bipolar input range, making it ideal for high voltage applications which require a wide dynamic range. The LTC2336-18 achieves $\pm 4LSB$ INL maximum, no missing codes at 18-bits and 100dB SNR.

The LTC2336-18 has an onboard single-shot capable reference buffer and low drift (20ppm/°C max) 2.048V temperature-compensated reference. The LTC2336-18 also has a high speed SPI-compatible serial interface that supports 1.8V, 2.5V, 3.3V and 5V logic while also featuring a daisy-chain mode. The fast 250ksps throughput with no cycle latency makes the LTC2336-18 ideally suited for a wide variety of high speed applications. An internal oscillator sets the conversion time, easing external timing considerations. The LTC2336-18 dissipates only 28mW and automatically naps between conversions, leading to reduced power dissipation that scales with the sampling rate. A sleep mode is also provided to reduce the power consumption of the LTC2336-18 to 300 μ W for further power savings during inactive periods.

CONVERTER OPERATION

The LTC2336-18 operates in two phases. During the acquisition phase, the charge redistribution capacitor D/A converter (CDAC) is connected to the outputs of the resistor divider networks that pins IN^+ and IN^- drive to sample an attenuated and level-shifted version of the differential analog input voltage as shown in Figure 3. A rising edge on the CNV pin initiates a conversion. During the conversion phase, the 18-bit CDAC is sequenced through a successive approximation algorithm, effectively comparing the sampled input with binary-weighted fractions of the reference voltage (e.g. $V_{REFBUF}/2$, $V_{REFBUF}/4$... $V_{REFBUF}/262144$) using the differential comparator. At the end of conversion, the CDAC output approximates the sampled analog input. The ADC control logic then prepares the 18-bit digital output code for serial transfer.

TRANSFER FUNCTION

The LTC2336-18 digitizes the full-scale voltage of $\pm 5 \cdot REFBUF$ into 2^{18} levels, resulting in an LSB size of 156 μ V

with $REFBUF = 4.096V$. The ideal transfer function is shown in Figure 2. The output data is in 2's complement format.

ANALOG INPUT

The analog inputs of the LTC2336-18 are fully differential to maximize the signal swing that can be digitized. The analog inputs can be modeled by the equivalent circuit shown in Figure 3. The back-to-back diodes at the inputs form clamps that provide ESD protection. Each input drives a resistor divider network that has a total impedance of 2k Ω . The resistor divider network attenuates and level shifts the $\pm 2.5 \cdot REFBUF$ true bipolar signal swing of each input to the 0- $REFBUF$ input signal swing of the ADC core. In the acquisition phase, 45pF (C_{IN}) from the sampling CDAC in series with approximately 50 Ω (R_{ON}) from the on-resistance of the sampling switch is connected to

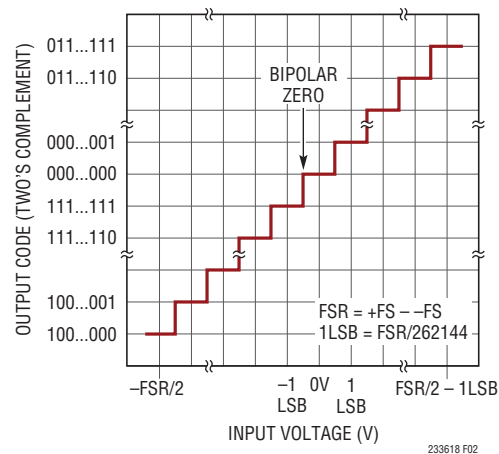

Figure 2. LTC2336-18 Transfer Function

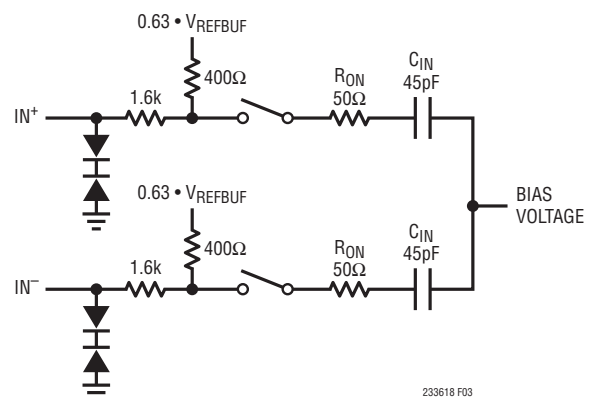

Figure 3. The Equivalent Circuit for the Differential Analog Input of the LTC2336-18

233618fa

APPLICATIONS INFORMATION

the output of the resistor divider network. Any unwanted signal that is common to both inputs will be reduced by the common mode rejection of the ADC core and resistor divider network. The inputs of the ADC core draw a current spike while charging the C_{IN} capacitors during acquisition.

INPUT DRIVE CIRCUITS

A low impedance source can directly drive the high impedance inputs of the LTC2336-18 without gain error. A high impedance source should be buffered to minimize settling time during acquisition and to optimize the distortion performance of the ADC. Minimizing settling time is important even for DC inputs, because the ADC inputs draw a current spike when entering acquisition.

For best performance, a buffer amplifier should be used to drive the analog inputs of the LTC2336-18. The amplifier provides low output impedance to minimize gain error and allows for fast settling of the analog signal during the acquisition phase. It also provides isolation between the signal source and the ADC inputs which draw a small current spike during acquisition.

Input Filtering

The noise and distortion of the buffer amplifier and signal source must be considered since they add to the ADC noise and distortion. Noisy input signals should be filtered prior to the buffer amplifier input with a low bandwidth filter to minimize noise. The simple 1-pole RC lowpass filter shown in Figure 4 is sufficient for many applications.

The input resistor divider network, sampling switch on-resistance (R_{ON}) and the sample capacitor (C_{IN}) form a second lowpass filter that limits the input bandwidth to the ADC core to 7MHz. A buffer amplifier with a low noise density must be selected to minimize the degradation of the SNR over this bandwidth.

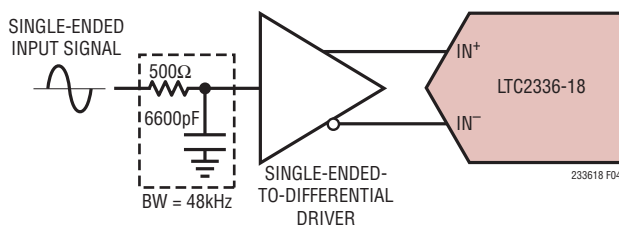

Figure 4. Input Signal Chain

High quality capacitors and resistors should be used in the RC filters since these components can add distortion. NPO and silver mica type dielectric capacitors have excellent linearity. Carbon surface mount resistors can generate distortion from self heating and from damage that may occur during soldering. Metal film surface mount resistors are much less susceptible to both problems.

Single-Ended-to-Differential Conversion

For single-ended input signals, a single-ended-to-differential conversion circuit must be used to produce a differential signal at the inputs of the LTC2336-18. The LT[®]1469 high speed dual operational amplifier is recommended for performing single-ended-to-differential conversions as shown in Figure 5a. In this case, the first amplifier is configured as a unity gain buffer and the single-ended input signal directly drives the high impedance input of this amplifier. Figure 5b shows the resulting FFT when the LT1469 is used to drive the LTC2336-18 in this configuration.

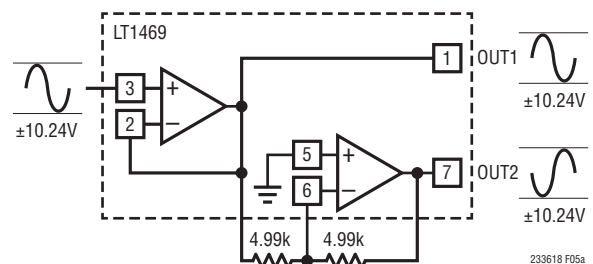

Figure 5a. LT1469 Converting a $\pm 10.24V$ Single-Ended Signal to a $\pm 20.48V$ Differential Input Signal

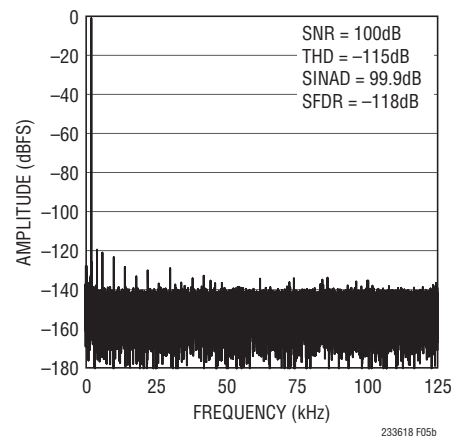

Figure 5b. 128k Point FFT Plot with $f_{IN} = 2kHz$ for Circuit Shown in Figure 5a

APPLICATIONS INFORMATION

Fully Differential Inputs

To achieve the full distortion performance of the LTC2336-18, a low distortion fully differential signal source driven through the LT1469 configured as two unity gain buffers as shown in Figure 6 can be used to get the full data sheet THD specification of -115dB .

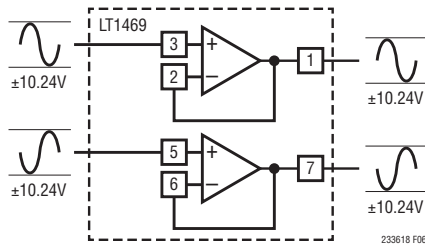

Figure 6. LT1469 Buffering a Fully Differential Signal Source

ADC REFERENCE

There are three ways of providing the ADC reference. The first is to use both the internal reference and reference buffer. The second is to externally overdrive the internal reference and use the internal reference buffer. The third is to disable the internal reference buffer and overdrive the REFBUF pin from an external source. The following tables give examples of these cases and the resulting bipolar input ranges.

Table 1. Internal Reference with Internal Buffer

REFIN	REFBUF	BIPOLAR INPUT RANGE
2.048V	4.096V	$\pm 10.24\text{V}$

Table 2. External Reference with Internal Buffer

REFIN (OVERDRIVE)	REFBUF	BIPOLAR INPUT RANGE
1.25V (Min)	2.5V	$\pm 6.25\text{V}$
2.048V	4.096V	$\pm 10.24\text{V}$
2.4V (Max)	4.8V	$\pm 12\text{V}$

Table 3. External Reference Unbuffered

REFIN	REFBUF (OVERDRIVE)	BIPOLAR INPUT RANGE
0V	2.5V (Min)	$\pm 6.25\text{V}$
0V	5V (Max)	$\pm 12.5\text{V}$

Internal Reference with Internal Buffer

The LTC2336-18 has an on-chip, low noise, low drift ($20\text{ppm}/^\circ\text{C}$ max), temperature compensated bandgap reference that is factory trimmed to 2.048V. It is internally connected to a reference buffer as shown in Figure 7a and is available at REFIN (Pin 8). REFIN should be bypassed to GND with a 100nF ceramic capacitor to minimize noise. The reference buffer gains the REFIN voltage by 2 to 4.096V at REFBUF (Pin 7). So the input range is $\pm 10.24\text{V}$, as shown in Table 1. Bypass REFBUF to GND with at least a $47\mu\text{F}$ ceramic capacitor (X7R, 10V, 1210 size) to compensate the reference buffer and minimize noise.

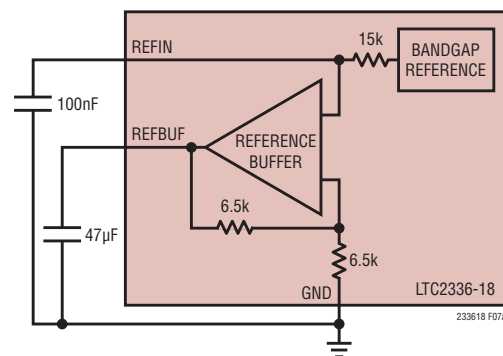

Figure 7a. LTC2336-18 Internal Reference Circuit

External Reference with Internal Buffer

If more accuracy and/or lower drift is desired, REFIN can be easily overdriven by an external reference since a 15k resistor is in series with the reference as shown in Figure 7b. REFIN can be overdriven in the range from 1.25V to 2.4V. The resulting voltage at REFBUF will be $2 \cdot \text{REFIN}$. So the input range is $\pm 5 \cdot \text{REFIN}$, as shown in Table 2. Linear Technology offers a portfolio of high performance references designed to meet the needs of many applications. With its small size, low power, and high accuracy, the LTC6655-2.048 is well suited for use with the LTC2336-18 when overdriving the internal reference. The LTC6655-2.048 offers 0.025% (max) initial accuracy and $2\text{ppm}/^\circ\text{C}$ (max) temperature coefficient for high precision applications. The LTC6655-2.048 is fully specified over the H-grade temperature range and complements the extended temperature range of the LTC2336-18 up to 125°C . Bypassing the LTC6655-2.048 with a $2.7\mu\text{F}$ to $100\mu\text{F}$ ceramic capacitor close to the REFIN pin is recommended.

APPLICATIONS INFORMATION

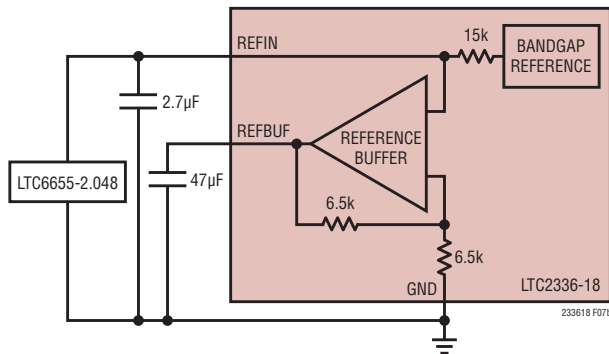

Figure 7b. Using the LTC6655-2.048 as an External Reference

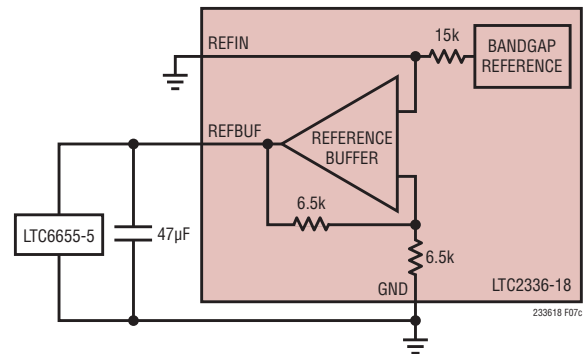

Figure 7c. Overdriving REFBUF Using the LTC6655-5

External Reference Unbuffered

The internal reference buffer can also be overdriven from 2.5V to 5V with an external reference at REFBUF as shown in Figure 7c. So the input ranges are $\pm 6.25\text{V}$ to $\pm 12.5\text{V}$, respectively, as shown in Table 3. To do so, REFIN must be grounded to disable the reference buffer. A 13k resistor loads the REFBUF pin when the reference buffer is disabled. To maximize the input signal swing and corresponding SNR, the LTC6655-5 is recommended when overdriving REFBUF. The LTC6655-5 offers the same small size, accuracy, drift and extended temperature range as the LTC6655-2.048. By using a 5V reference, an SNR of 102dB can be achieved. Bypassing the LTC6655-5 with a 47 μF ceramic capacitor (X5R, 0805 size) close to the REFBUF pin is recommended.

The REFBUF pin of the LTC2336-18 draws a charge (Q_{CONV}) from the external bypass capacitor during each conversion cycle. If the internal reference buffer is overdriven, the external reference must provide all of this charge with a DC current equivalent to $I_{\text{REFBUF}} = Q_{\text{CONV}}/t_{\text{CYC}}$. Thus, the DC current draw of REFBUF depends on the sampling rate and output code. In applications where a burst of samples is taken after idling for long periods, as shown in Figure 8, I_{REFBUF} quickly goes from approximately 390 μA to a maximum of 0.6mA for REFBUF = 5V at 250ksps. This step in DC current draw triggers a transient response in the external

reference that must be considered since any deviation in the voltage at REFBUF will affect the accuracy of the output code. If an external reference is used to overdrive REFBUF, the fast settling LTC6655-5 reference is recommended.

Internal Reference Buffer Transient Response

For optimum transient performance, the internal reference buffer should be used. The internal reference buffer uses a proprietary design that results in an output voltage change at REFBUF of less than 1LSB when responding to a sudden burst of conversions. This makes the internal reference buffer of the LTC2336-18 truly single-shot capable since the first sample taken after idling will yield the same result as a sample taken after the transient response of the internal reference buffer has settled. Figure 9 shows the transient responses of the LTC2336-18 with the internal reference buffer and with the internal reference buffer overdriven by the LTC6655-5, both with a bypass capacitance of 47 μF .

DYNAMIC PERFORMANCE

Fast Fourier Transform (FFT) techniques are used to test the ADC's frequency response, distortion and noise at the rated throughput. By applying a low distortion sine wave and analyzing the digital output using an FFT algorithm, the ADC's spectral content can be examined for frequencies outside the

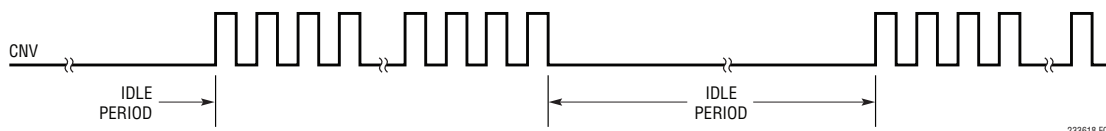

Figure 8. CNV Waveform Showing Burst Sampling

APPLICATIONS INFORMATION

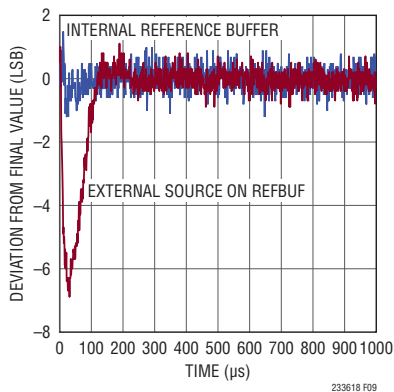

Figure 9. Transient Response of the LTC2336-18

fundamental. The LTC2336-18 provides guaranteed tested limits for both AC distortion and noise measurements.

Signal-to-Noise and Distortion Ratio (SINAD)

The signal-to-noise and distortion ratio (SINAD) is the ratio between the RMS amplitude of the fundamental input frequency and the RMS amplitude of all other frequency components at the A/D output. The output is band limited to frequencies from above DC and below half the sampling frequency. Figure 10 shows that the LTC2336-18 achieves a typical SINAD of 100dB at a 250kHz sampling rate with a 2kHz input.

Signal-to-Noise Ratio (SNR)

The signal-to-noise ratio (SNR) is the ratio between the RMS amplitude of the fundamental input frequency and the RMS amplitude of all other frequency components except the first five harmonics and DC. Figure 10 shows

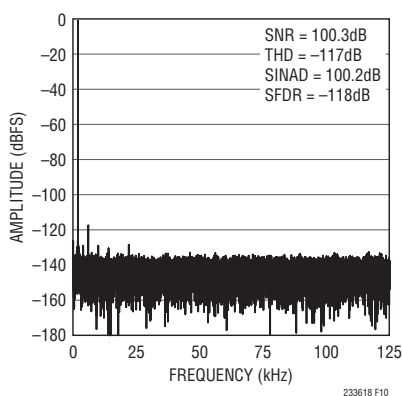

Figure 10. 32k Point FFT of the LTC2336-18

that the LTC2336-18 achieves a typical SNR of 100dB at a 250kHz sampling rate with a 2kHz input.

Total Harmonic Distortion (THD)

Total Harmonic Distortion (THD) is the ratio of the RMS sum of all harmonics of the input signal to the fundamental itself. The out-of-band harmonics alias into the frequency band between DC and half the sampling frequency ($f_{\text{SAMPL}}/2$). THD is expressed as:

$$\text{THD} = 20 \log \frac{\sqrt{V_2^2 + V_3^2 + V_4^2 + \dots + V_N^2}}{V_1}$$

where V_1 is the RMS amplitude of the fundamental frequency and V_2 through V_N are the amplitudes of the second through Nth harmonics.

POWER CONSIDERATIONS

The LTC2336-18 provides two power supply pins: the 5V power supply (V_{DD}), and the digital input/output interface power supply (OV_{DD}). The flexible OV_{DD} supply allows the LTC2336-18 to communicate with any digital logic operating between 1.8V and 5V, including 2.5V and 3.3V systems.

Power Supply Sequencing

The LTC2336-18 does not have any specific power supply sequencing requirements. Care should be taken to adhere to the maximum voltage relationships described in the Absolute Maximum Ratings section. The LTC2336-18 has a power-on reset (POR) circuit that will reset the LTC2336-18 at initial power-up or whenever the power supply voltage drops below 2V. Once the supply voltage reenters the nominal supply voltage range, the POR will re-initialize the ADC. No conversions should be initiated until 200µs after a POR event to ensure the re-initialization period has ended. Any conversions initiated before this time will produce invalid results.

TIMING AND CONTROL

CNV Timing

The LTC2336-18 conversion is controlled by CNV. A rising edge on CNV will start a conversion and power up

APPLICATIONS INFORMATION

the LTC2336-18. Once a conversion has been initiated, it cannot be restarted until the conversion is complete. For optimum performance, CNV should be driven by a clean low jitter signal. Converter status is indicated by the BUSY output which remains high while the conversion is in progress. To ensure that no errors occur in the digitized results, any additional transitions on CNV should occur within 40ns from the start of the conversion or after the conversion has been completed. Once the conversion has completed, the LTC2336-18 powers down.

Acquisition

A proprietary sampling architecture allows the LTC2336-18 to begin acquiring the input signal for the next conversion 527ns after the start of the current conversion. This extends the acquisition time to 3.460 μ s, easing settling requirements and allowing the use of extremely low power ADC drivers. (Refer to the Timing Diagram.)

Internal Conversion Clock

The LTC2336-18 has an internal clock that is trimmed to achieve a maximum conversion time of 3 μ s.

Auto Nap Mode

The LTC2336-18 automatically enters nap mode after a conversion has been completed and completely powers up once a new conversion is initiated on the rising edge of CNV. During nap mode, only the ADC core powers down and all other circuits remain active. During nap, data from the last conversion can be clocked out. The auto nap mode feature will reduce the power dissipation of the LTC2336-18 as the sampling frequency is reduced. Since full power is consumed only during a conversion, the ADC core of the LTC2336-18 remains powered down for a larger fraction of the conversion cycle (t_{CYC}) at lower sample rates, thereby reducing the average power dissipation which scales with the sampling rate as shown in Figure 11.

Sleep Mode

The auto nap mode feature provides limited power savings since only the ADC core powers down. To obtain greater power savings, the LTC2336-18 provides a sleep mode. During sleep mode, the entire part is powered down except for a small

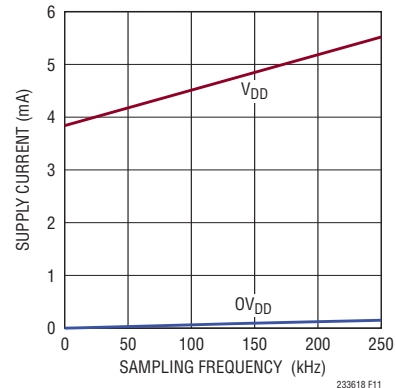

Figure 11. Power Supply Current of the LTC2336-18 Versus Sampling Rate.

standby current resulting in a power dissipation of 300 μ W. To enter sleep mode, toggle CNV twice with no intervening rising edge on SCK. The part will enter sleep mode on the falling edge of BUSY from the last conversion initiated. Once in sleep mode, a rising edge on SCK will wake the part up. Upon emerging from sleep mode, wait t_{WAKE} seconds before initiating a conversion to allow the reference and reference buffer to wake up and charge the bypass capacitors at REFIN and REFBUF. (Refer to the Timing Diagrams section for more detailed timing information about sleep mode.)

DIGITAL INTERFACE

The LTC2336-18 has a serial digital interface. The flexible O_V_{DD} supply allows the LTC2336-18 to communicate with any digital logic operating between 1.8V and 5V, including 2.5V and 3.3V systems.

The serial output data is clocked out on the SDO pin when an external clock is applied to the SCK pin if SDO is enabled. Clocking out the data after the conversion will yield the best performance. With a shift clock frequency of at least 20MHz, a 250ksps throughput is still achieved. The serial output data changes state on the rising edge of SCK and can be captured on the falling edge or next rising edge of SCK. D17 remains valid till the first rising edge of SCK.

The serial interface on the LTC2336-18 is simple and straightforward to use. The following sections describe the operation of the LTC2336-18. Several modes are provided depending on whether a single or multiple ADCs share the SPI bus or are daisy-chained.

APPLICATIONS INFORMATION

Normal Mode, Single Device

When CHAIN = 0, the LTC2336-18 operates in normal mode. In normal mode, RDL/SDI enables or disables the serial data output pin SDO. If RDL/SDI is high, SDO is in high impedance. If RDL/SDI is low, SDO is driven. Figure 12

shows a single LTC2336-18 operated in normal mode with CHAIN and RDL/SDI tied to ground. With RDL/SDI grounded, SDO is enabled and the MSB(D17) of the new conversion data is available at the falling edge of BUSY. This is the simplest way to operate the LTC2336-18.

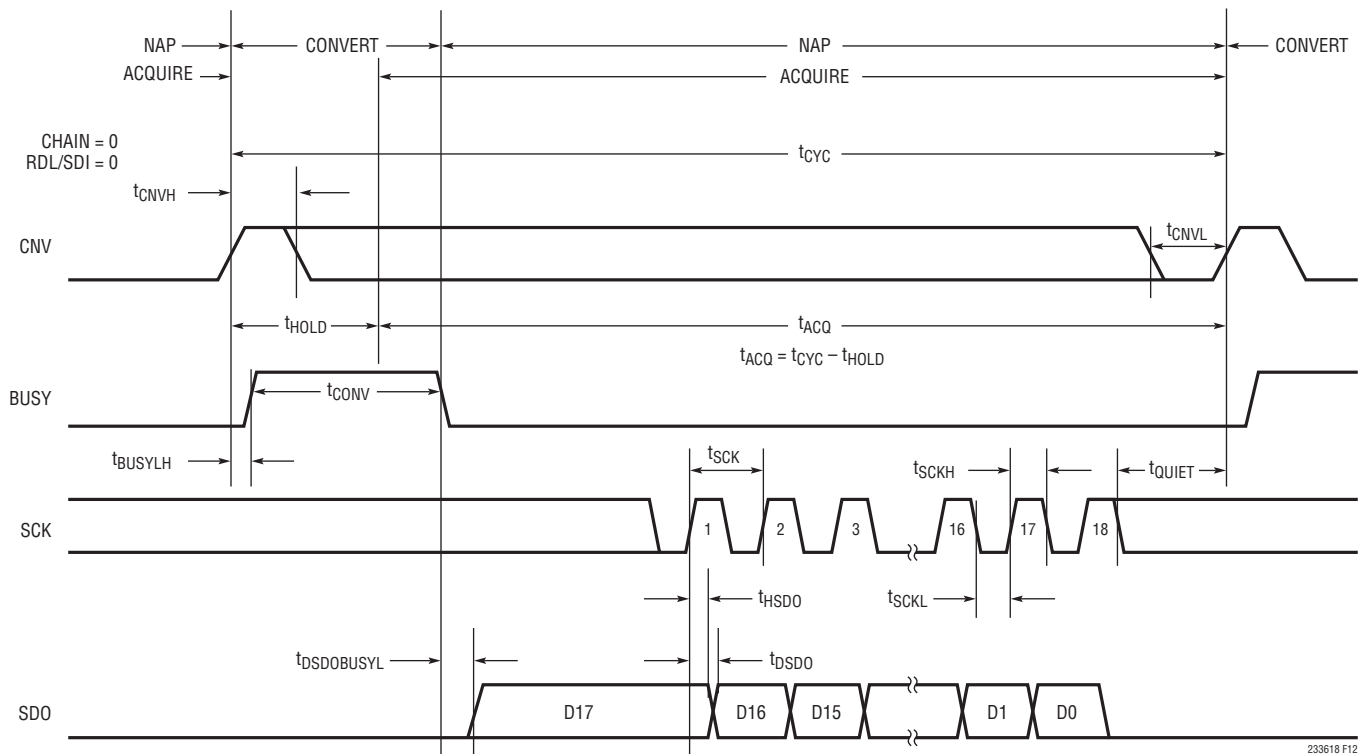
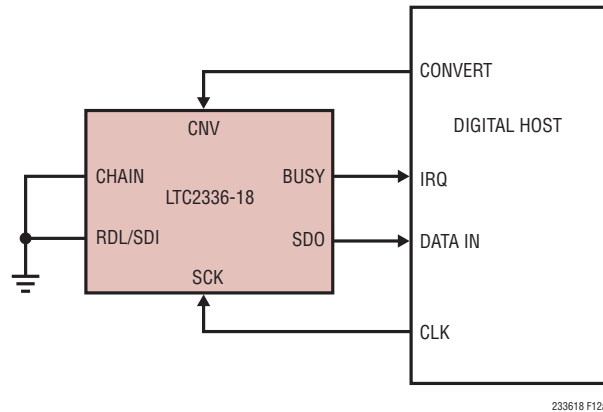

Figure 12. Using a Single LTC2336-18 in Normal Mode

APPLICATIONS INFORMATION

Normal Mode, Multiple Devices

Figure 13 shows multiple LTC2336-18 devices operating in normal mode (CHAIN = 0) sharing CNV, SCK and SDO. By sharing CNV, SCK and SDO, the number of required signals to operate multiple ADCs in parallel is reduced. Since SDO is shared, the RDL/SDI input of each ADC must

be used to allow only one LTC2336-18 to drive SDO at a time in order to avoid bus conflicts. As shown in Figure 13, the RDL/SDI inputs idle high and are individually brought low to read data out of each device between conversions. When RDL/SDI is brought low, the MSB of the selected device is output onto SDO.

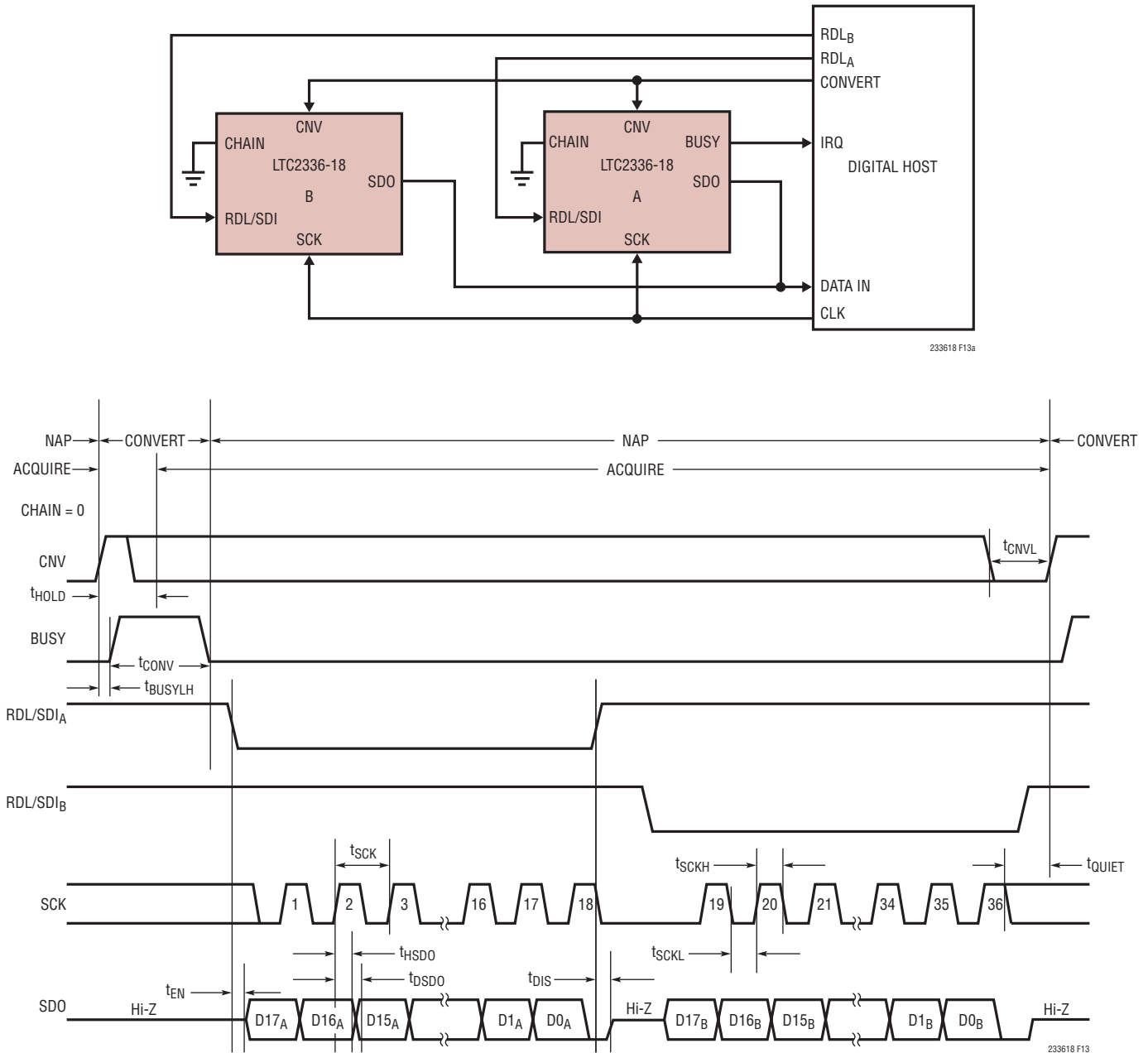

Figure 13. Normal Mode with Multiple Devices Sharing CNV, SCK, and SDO

APPLICATIONS INFORMATION

Chain Mode, Multiple Devices

When CHAIN = OV_{DD} , the LTC2336-18 operates in chain mode. In chain mode, SDO is always enabled and RDL/SDI serves as the serial data input pin (SDI) where daisy-chain data output from another ADC can be input. This is useful for applications where hardware constraints

may limit the number of lines needed to interface to a large number of converters. Figure 14 shows an example with two daisy-chained devices. The MSB of converter A will appear at SDO of converter B after 18 SCK cycles. The MSB of converter A is clocked in at the SDI/RDL pin of converter B on the rising edge of the first SCK.

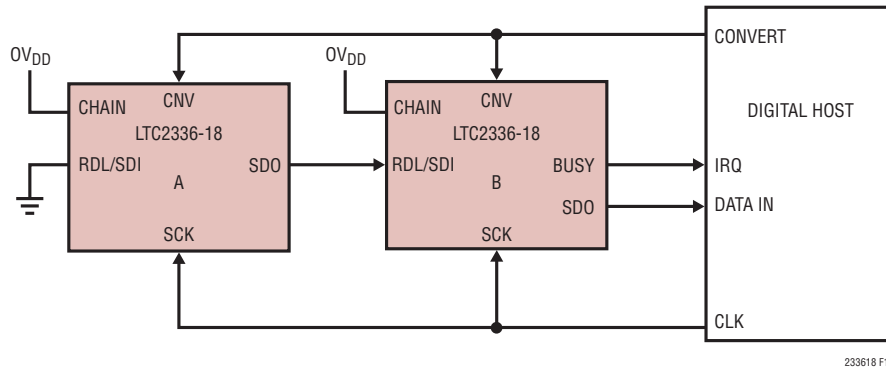

233618 F14a

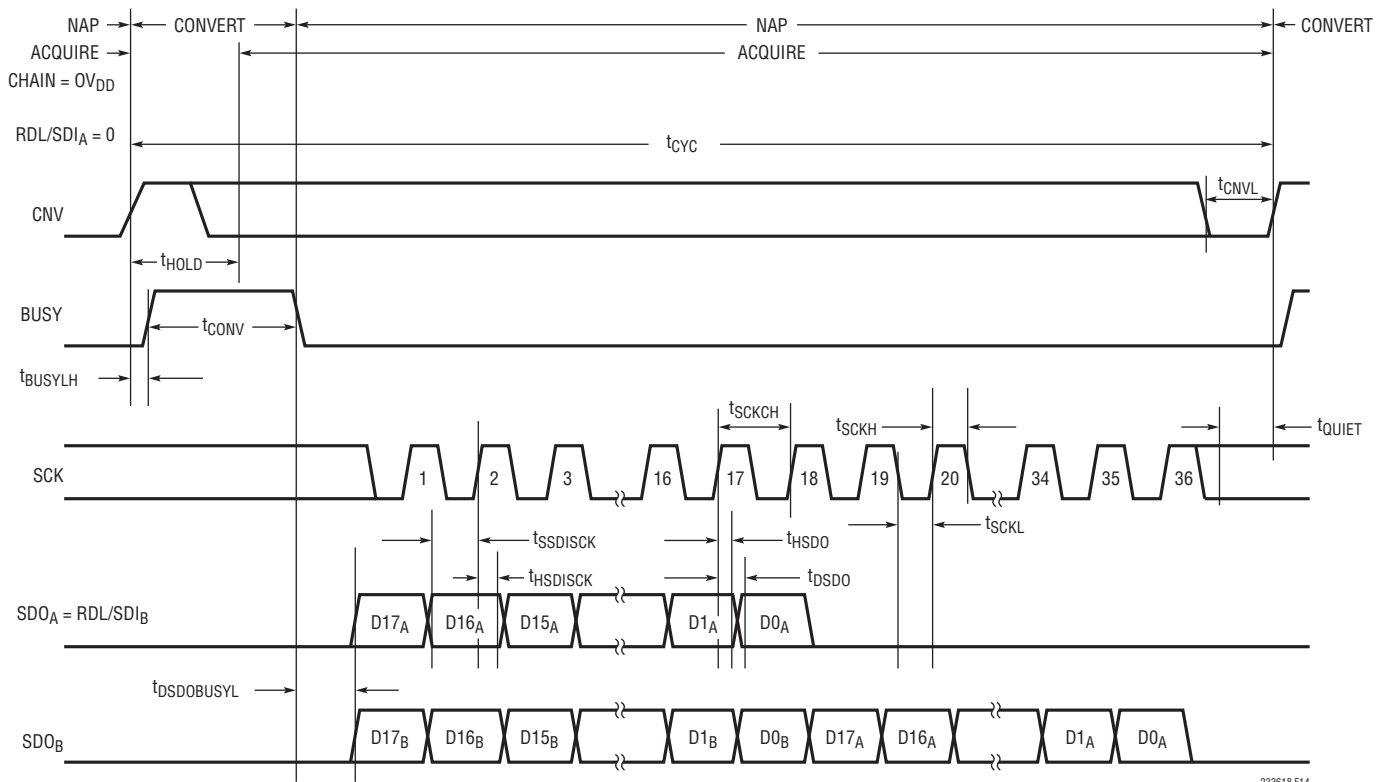

233618 F14

Figure 14. Chain Mode Timing Diagram

APPLICATIONS INFORMATION

Sleep Mode

To enter sleep mode, toggle CNV twice with no intervening rising edge on SCK as shown in Figure 15. The part will enter sleep mode on the falling edge of BUSY from the

last conversion initiated. Once in sleep mode, a rising edge on SCK will wake the part up. Upon emerging from sleep mode, wait t_{WAKE} seconds before initiating a conversion to allow the reference and reference buffer to wake up and charge the bypass capacitors at REFIN and REFBUF.

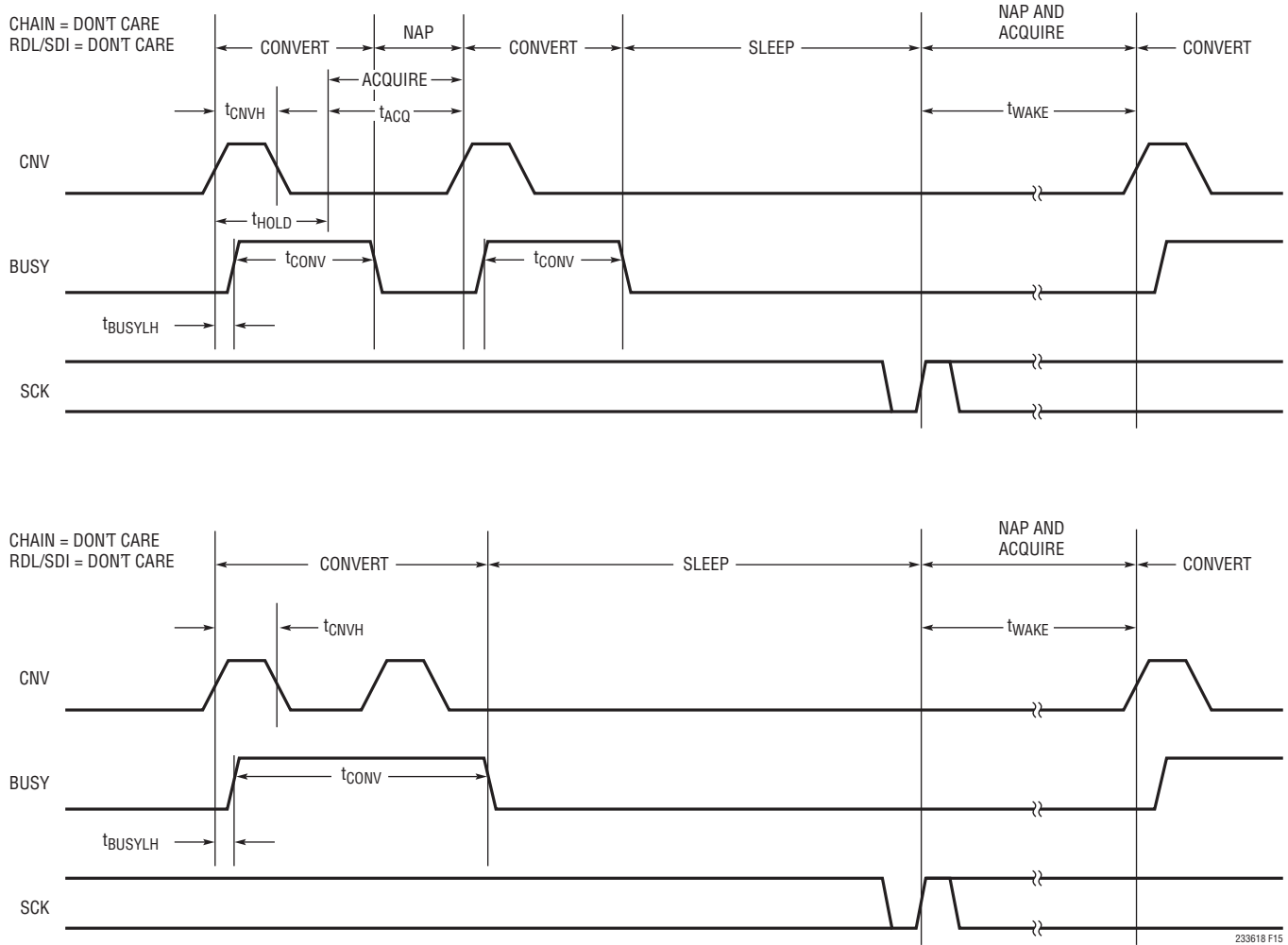

Figure 15. Sleep Mode Timing Diagram

BOARD LAYOUT

To obtain the best performance from the LTC2336-18 a printed circuit board (PCB) is recommended. Layout for the PCB should ensure the digital and analog signal lines are separated as much as possible. In particular, care should be taken not to run any digital clocks or signals alongside analog signals or underneath the ADC.

Recommended Layout

The following is an example of a recommended PCB layout. A single solid ground plane is used. Bypass capacitors to the supplies are placed as close as possible to the supply pins. Low impedance common returns for these bypass capacitors are essential to the low noise operation of the ADC. The analog input traces are screened by ground. For more details and information refer to DC1908, the evaluation kit for the LTC2336-18.

Partial Top Silkscreen

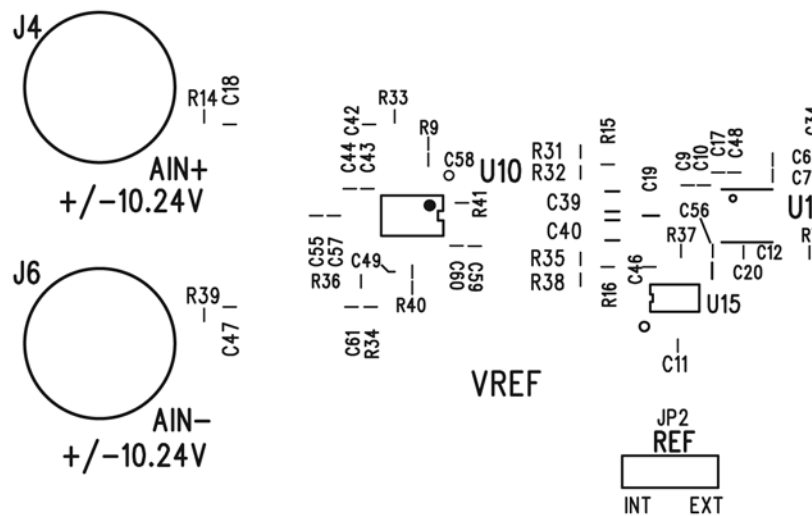

Partial Layer 1 Component Side

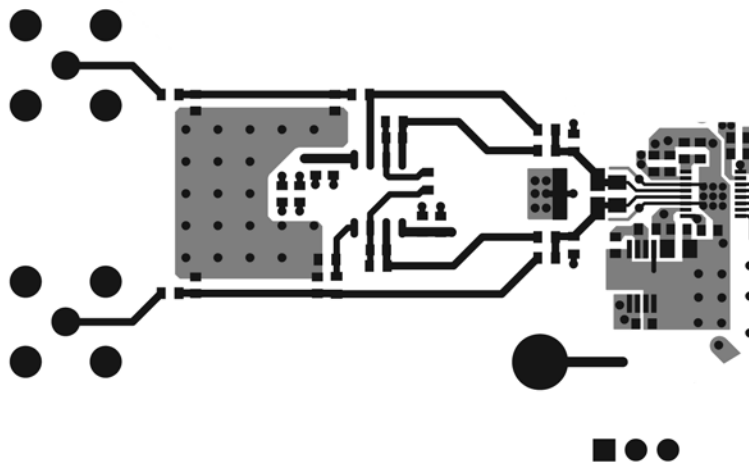

BOARD LAYOUT

Partial Layer 2 Ground Plane

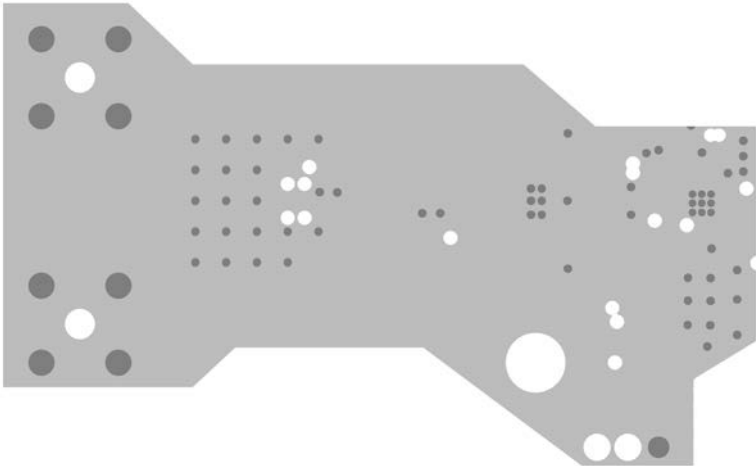

Partial Layer 3 Power Plane

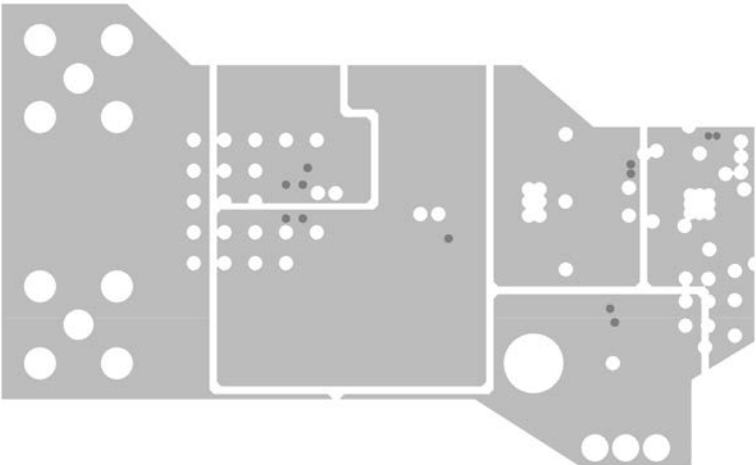

Partial Layer 4 Bottom Layer

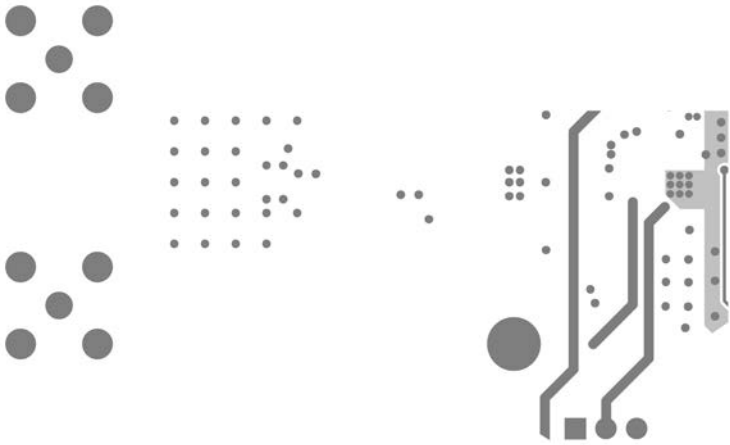

BOARD LAYOUT

Partial Schematic of Demoboard

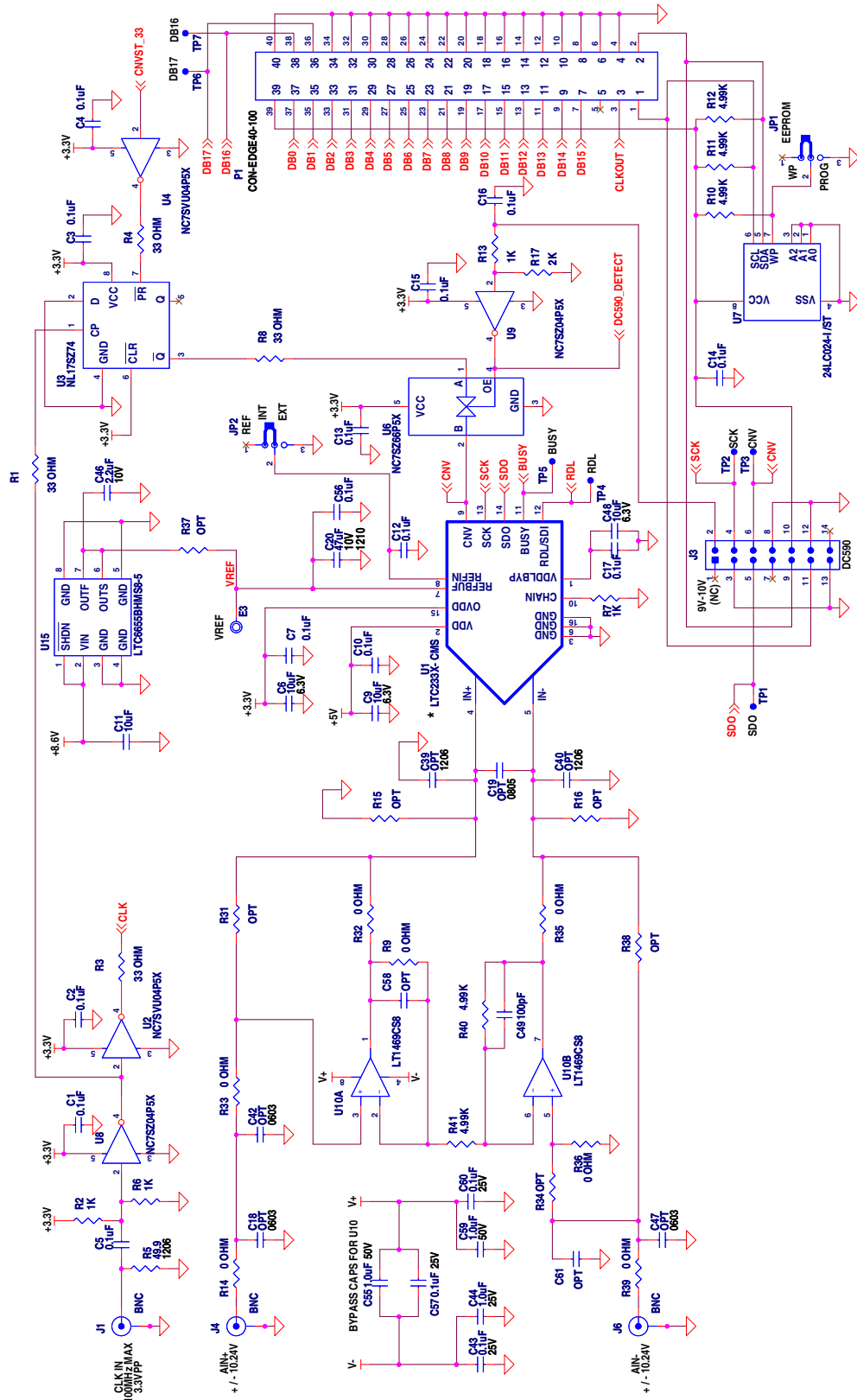

PACKAGE DESCRIPTION

Please refer to <http://www.linear.com/product/LTC2336-18#packaging> for the most recent package drawings.

MS Package
16-Lead Plastic MSOP
 (Reference LTC DWG # 05-08-1669 Rev A)

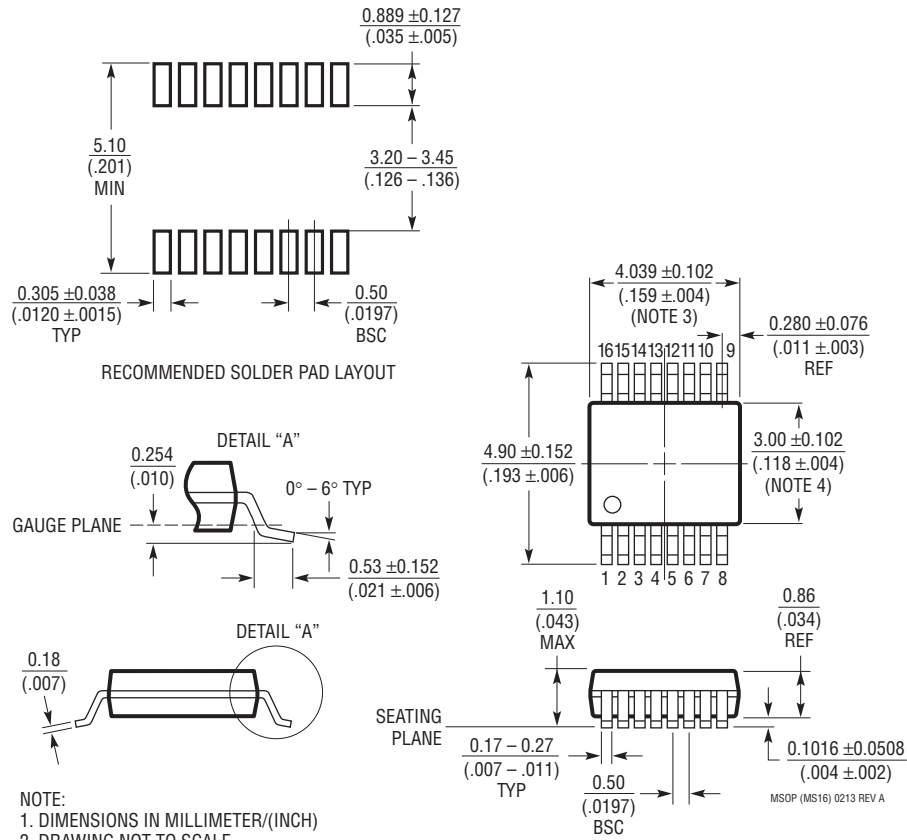

- NOTE:
1. DIMENSIONS IN MILLIMETER/(INCH)
 2. DRAWING NOT TO SCALE
 3. DIMENSION DOES NOT INCLUDE MOLD FLASH, PROTRUSIONS OR GATE BURRS.
MOLD FLASH, PROTRUSIONS OR GATE BURRS SHALL NOT EXCEED 0.152mm (.006") PER SIDE
 4. DIMENSION DOES NOT INCLUDE INTERLEAD FLASH OR PROTRUSIONS.
INTERLEAD FLASH OR PROTRUSIONS SHALL NOT EXCEED 0.152mm (.006") PER SIDE
 5. LEAD COPLANARITY (BOTTOM OF LEADS AFTER FORMING) SHALL BE 0.102mm (.004") MAX

REVISION HISTORY

REV	DATE	DESCRIPTION	PAGE NUMBER
A	08/16	Updated graphs G01, G02, and G03	6

TYPICAL APPLICATION

LT1469 Configured to Convert a $\pm 10.24\text{V}$ Single-Ended Signal to a $\pm 20.48\text{V}$ Differential Signal

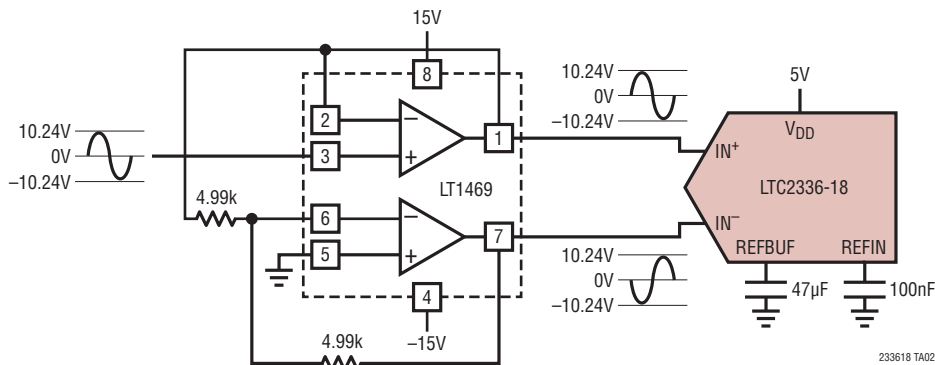

RELATED PARTS

PART NUMBER	DESCRIPTION	COMMENTS
ADCs		
LTC2379-18/LTC2378-18/LTC2377-18/LTC2376-18	18-Bit, 1.6Msps/1Msps/500ksps/250ksps Serial, Low Power ADC	2.5V Supply, Differential Input, 101.2dB SNR, $\pm 5\text{V}$ Input Range, DGC, Pin-Compatible Family in MSOP-16 and 4mm \times 3mm DFN-16 Packages
LTC2380-16/LTC2378-16/LTC2377-16/LTC2376-16	16-Bit, 2Msps/1Msps/500ksps/250ksps Serial, Low Power ADC	2.5V Supply, Differential Input, 96.2dB SNR, $\pm 5\text{V}$ Input Range, DGC, Pin-Compatible Family in MSOP-16 and 4mm \times 3mm DFN-16 Packages
LTC2369-18/LTC2368-18/LTC2367-18/LTC2364-18	18-Bit, 1.6Msps/1Msps/500ksps/250ksps Serial, Low Power ADC	2.5V Supply, Pseudo-Differential Unipolar Input, 96.5dB SNR, 0V to 5V Input Range, Pin-Compatible Family in MSOP-16 and 4mm \times 3mm DFN-16 Packages
LTC2370-16/LTC2368-16/LTC2367-16/LTC2364-16	16-Bit, 2Msps/1Msps/500ksps/250ksps Serial, Low Power ADC	2.5V Supply, Pseudo-Differential Unipolar Input, 94dB SNR, 0V to 5V Input Range, Pin-Compatible Family in MSOP-16 and 4mm \times 3mm DFN-16 Packages
LTC2389-18/LTC2389-16	18-Bit/16-Bit, 2.5Msps Parallel/Serial ADC	5V Supply, Pin-Configurable Input Range, 99.8dB/96dB SNR, Parallel or Serial I/O 7mm \times 7mm LQFP-48 and QFN-48 Packages
LTC1609	16-Bit, 200ksps Serial ADC	$\pm 10\text{V}$, Configurable Unipolar/Bipolar Input, Single 5V Supply, SSOP-28 and SO-20 Packages
LTC1606/LTC1605	16-Bit, 200ksps/100ksps Parallel ADCs	$\pm 10\text{V}$, 75mW/55mW 5V Pin Compatible ADCs
LTC1859/LTC1858/LTC1857	16-/14-/12-Bit, 8-Channel 100ksps Serial ADCs	$\pm 10\text{V}$, SoftSpan™, Single-Ended or Differential Inputs, Single 5V Supply, SSOP-28 Package
DACs		
LTC2756/LTC2757	18-Bit, Single Serial/Parallel I_{OUT} SoftSpan DAC	$\pm 1\text{LSB}$ INL/DNL, Software-Selectable Ranges, SSOP-28/7mm \times 7mm LQFP-48 Package
LTC2641	16-Bit/14-Bit/12-Bit Single Serial V_{OUT} DAC	$\pm 1\text{LSB}$ INL /DNL, MSOP-8 Package, 0V to 5V Output
LTC2630	12-Bit/10-Bit/8-Bit Single V_{OUT} DACs	$\pm 1\text{LSB}$ INL (12 Bits), Internal Reference, SC70 6-Pin Package
References		
LTC6655	Precision Low Drift Low Noise Buffered Reference	5V/2.5V/2.048V/1.2V, 2ppm/°C, 0.25ppm Peak-to-Peak Noise, MSOP-8 Package
LTC6652	Precision Low Drift Low Noise Buffered Reference	5V/2.5V/2.048V/1.2V, 5ppm/°C, 2.1ppm Peak-to-Peak Noise, MSOP-8 Package
Amplifiers		
LT1468/LT1469	Single/Dual 90MHz, 22V/ μs , 16-Bit Accurate Op Amp	Low Input Offset: 75 μV /125 μV

Looking for pricing, stock, or lifecycle information?

Click below to explore more details on WIN SOURCE:

 [View LTC2336HMS-18#PBF on WIN SOURCE](#)

 [Analog Devices Inc. Information](#)

Optimize Your Supply Chain with WIN SOURCE Solutions

-  Global Sourcing Solution
-  Obsolete Management
-  Cost Control Management
-  Shortage Management
-  Alternative Solution
-  Excess Inventory Management