



**THE DATASHEET OF  
LTC2411-1IMS#PBF**



## FEATURES

- 24-Bit ADC in an MS10 Package
- Low Supply Current (200 $\mu$ A in Conversion Mode and 4 $\mu$ A in Autosleep Mode)
- Differential Input and Differential Reference with GND to  $V_{CC}$  Common Mode Range
- 2ppm INL, No Missing Codes
- 4ppm Full-Scale Error and 1ppm Offset
- 0.29ppm Noise
- No Latency: Digital Filter Settles in a Single Cycle. Each Conversion Is Accurate, Even After an Input Step
- Single Supply 2.7V to 5.5V Operation
- Internal Oscillator—No External Components Required
- 110dB Min, Pin Selectable 50Hz/60Hz Notch Filter (LTC2411)
- Simultaneous 50Hz/60Hz Rejection (LTC2411-1)

## APPLICATIONS

- Direct Sensor Digitizer
- Weight Scales
- Direct Temperature Measurement
- Gas Analyzers
- Strain Gauge Transducers
- Instrumentation
- Data Acquisition
- Industrial Process Control
- 6-Digit DVMs

## DESCRIPTION

The **LTC<sup>®</sup>2411/LTC2411-1** are 2.7V to 5.5V micropower 24-bit differential  $\Delta\Sigma$  analog-to-digital converters with an integrated oscillator, 2ppm INL and 0.29ppm RMS noise. They use delta-sigma technology and provide single cycle settling time for multiplexed applications. Through a single pin, the LTC2411 can be configured for better than 110dB differential mode rejection at 50Hz or 60Hz  $\pm 2\%$ , and the LTC2411-1 can provide better than 87dB input differential mode rejection over the range of 49Hz to 61.2Hz, or they can be driven by an external oscillator for a user-defined rejection frequency. The LTC2411 and LTC2411-1 are identical when driven by an external oscillator. The internal oscillator requires no external frequency setting components.

The converters accept any external differential reference voltage from 0.1V to  $V_{CC}$  for flexible ratiometric and remote sensing measurement configurations. The full-scale differential input range is from  $-0.5V_{REF}$  to  $0.5V_{REF}$ . The reference common mode voltage,  $V_{REFCM}$ , and the input common mode voltage,  $V_{INCM}$ , may be independently set anywhere within the GND to  $V_{CC}$  range of the LTC2411/LTC2411-1. The DC common mode input rejection is better than 140dB.

The LTC2411/LTC2411-1 communicate through a flexible 3-wire digital interface that is compatible with SPI and MICROWIRE protocols.

LT, LT, LTC, LTM, Linear Technology and the Linear logo are registered trademarks and No Latency  $\Delta\Sigma$  is a trademark of Linear Technology Corporation. All other trademarks are the property of their respective owners.

## TYPICAL APPLICATION

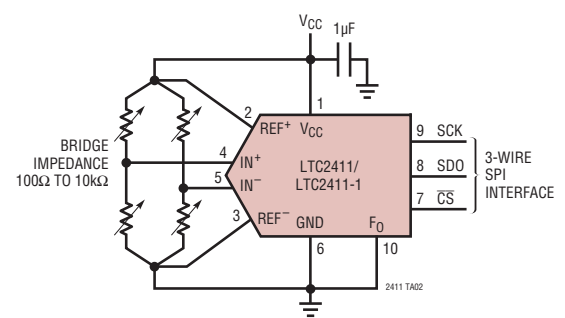
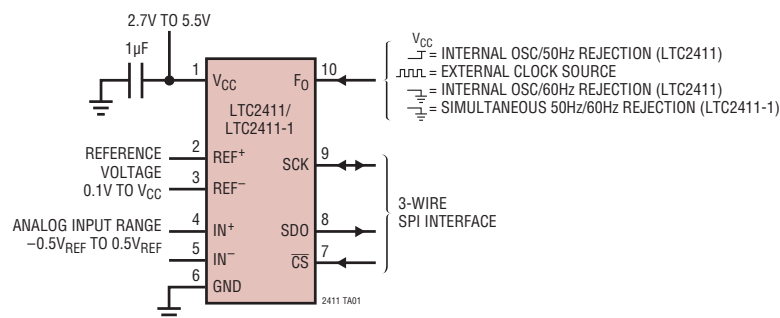

2411fa

# LTC2411/LTC2411-1

## ABSOLUTE MAXIMUM RATINGS

(Notes 1, 2)

Supply Voltage ( $V_{CC}$ ) to GND .....	-0.3V to 7V
Analog Input Pins Voltage to GND .....	-0.3V to ( $V_{CC} + 0.3V$ )
Reference Input Pins Voltage to GND .....	-0.3V to ( $V_{CC} + 0.3V$ )
Digital Input Voltage to GND .....	-0.3V to ( $V_{CC} + 0.3V$ )
Digital Output Voltage to GND .....	-0.3V to ( $V_{CC} + 0.3V$ )
Operating Temperature Range	
LTC2411C .....	0°C to 70°C
LTC2411I .....	-40°C to 85°C
Storage Temperature Range .....	-65°C to 150°C
Lead Temperature (Soldering, 10 sec).....	300°C

## PIN CONFIGURATION

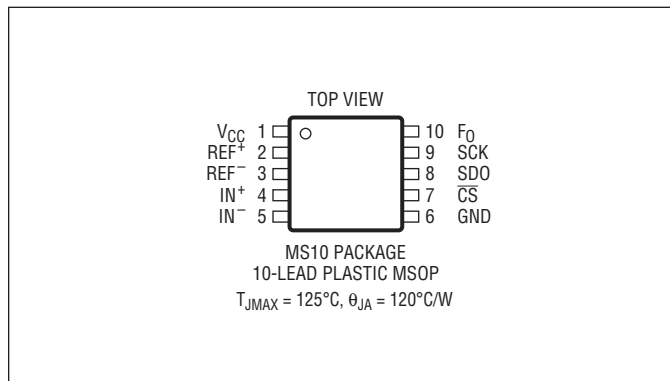

## ORDER INFORMATION

LEAD FREE FINISH	TAPE AND REEL	PART MARKING	PACKAGE DESCRIPTION	TEMPERATURE RANGE
LTC2411CMS#PBF	LTC2411CMS#TRPBF	LTNS	10-Lead Plastic MSOP	0°C to 70°C
LTC2411IMS#PBF	LTC2411IMS#TRPBF	LTNT	10-Lead Plastic MSOP	-40°C to 85°C
LTC2411-1CMS#PBF	LTC2411-1CMS#TRPBF	LTWV	10-Lead Plastic MSOP	0°C to 70°C
LTC2411-1IMS#PBF	LTC2411-1IMS#TRPBF	LTNN	10-Lead Plastic MSOP	-40°C to 85°C

Consult LTC Marketing for parts specified with wider operating temperature ranges.

Consult LTC Marketing for information on nonstandard lead based finish parts.

For more information on lead free part marking, go to: <http://www.linear.com/leadfree/>

For more information on tape and reel specifications, go to: <http://www.linear.com/tapeandreel/>

## ELECTRICAL CHARACTERISTICS

The ● denotes the specifications which apply over the full operating temperature range, otherwise specifications are at  $T_A = 25^\circ\text{C}$ . (Notes 3, 4)

PARAMETER	CONDITIONS	MIN	TYP	MAX	UNITS
Resolution (No Missing Codes)	$0.1V \leq V_{REF} \leq V_{CC}$ , $-0.5 \cdot V_{REF} \leq V_{IN} \leq 0.5 \cdot V_{REF}$ (Note 5)	●	24		Bits
Integral Nonlinearity	$4.5V \leq V_{CC} \leq 5.5V$ , $REF^+ = 2.5V$ , $REF^- = GND$ , $V_{INCM} = 1.25V$ (Note 6)	●	1		ppm of $V_{REF}$
	$5V \leq V_{CC} \leq 5.5V$ , $REF^+ = 5V$ , $REF^- = GND$ , $V_{INCM} = 2.5V$ (Note 6)	●	2	14	ppm of $V_{REF}$
	$REF^+ = 2.5V$ , $REF^- = GND$ , $V_{INCM} = 1.25V$ (Note 6)		6		ppm of $V_{REF}$
Offset Error	$2.5V \leq REF^+ \leq V_{CC}$ , $REF^- = GND$ , $GND \leq IN^+ = IN^- \leq V_{CC}$ (Note 14)	●	5	20	$\mu\text{V}$
Offset Error Drift	$2.5V \leq REF^+ \leq V_{CC}$ , $REF^- = GND$ , $GND \leq IN^+ = IN^- \leq V_{CC}$		20		$\text{nV}/^\circ\text{C}$
Positive Full-Scale Error	$2.5V \leq REF^+ \leq V_{CC}$ , $REF^- = GND$ , $IN^+ = 0.75REF^+$ , $IN^- = 0.25 \cdot REF^+$	●	4	12	ppm of $V_{REF}$
Positive Full-Scale Error Drift	$2.5V \leq REF^+ \leq V_{CC}$ , $REF^- = GND$ , $IN^+ = 0.75REF^+$ , $IN^- = 0.25 \cdot REF^+$		0.04		ppm of $V_{REF}/^\circ\text{C}$
Negative Full-Scale Error	$2.5V \leq REF^+ \leq V_{CC}$ , $REF^- = GND$ , $IN^+ = 0.25 \cdot REF^+$ , $IN^- = 0.75 \cdot REF^+$	●	4	12	ppm of $V_{REF}$

2411fa

## ELECTRICAL CHARACTERISTICS

The ● denotes the specifications which apply over the full operating temperature range, otherwise specifications are at  $T_A = 25^\circ\text{C}$ . (Notes 3, 4)

PARAMETER	CONDITIONS	MIN	TYP	MAX	UNITS
Negative Full-Scale Error Drift	$2.5\text{V} \leq \text{REF}^+ \leq V_{\text{CC}}$ , $\text{REF}^- = \text{GND}$ , $\text{IN}^+ = 0.25 \cdot \text{REF}^+$ , $\text{IN}^- = 0.75 \cdot \text{REF}^+$		0.04		ppm of $V_{\text{REF}}/^\circ\text{C}$
Total Unadjusted Error	$4.5\text{V} \leq V_{\text{CC}} \leq 5.5\text{V}$ , $\text{REF}^+ = 2.5\text{V}$ , $\text{REF}^- = \text{GND}$ , $V_{\text{INCM}} = 1.25\text{V}$ $5\text{V} \leq V_{\text{CC}} \leq 5.5\text{V}$ , $\text{REF}^+ = 5\text{V}$ , $\text{REF}^- = \text{GND}$ , $V_{\text{INCM}} = 2.5\text{V}$ $\text{REF}^+ = 2.5\text{V}$ , $\text{REF}^- = \text{GND}$ , $V_{\text{INCM}} = 1.25\text{V}$		3 3 6		ppm of $V_{\text{REF}}$ ppm of $V_{\text{REF}}$ ppm of $V_{\text{REF}}$
Output Noise	$5\text{V} \leq V_{\text{CC}} \leq 5.5\text{V}$ , $\text{REF}^+ = 5\text{V}$ , $V_{\text{REF}}^- = \text{GND}$ , $\text{GND} \leq \text{IN}^- = \text{IN}^+ \leq 5\text{V}$ , (Note 13)		1.45		$\mu\text{V}_{\text{RMS}}$

## CONVERTER CHARACTERISTICS

The ● denotes the specifications which apply over the full operating temperature range, otherwise specifications are at  $T_A = 25^\circ\text{C}$ . (Notes 3, 4)

PARAMETER	CONDITIONS	MIN	TYP	MAX	UNITS
Input Common Mode Rejection DC	$2.5\text{V} \leq \text{REF}^+ \leq V_{\text{CC}}$ , $\text{REF}^- = \text{GND}$ , $\text{GND} \leq \text{IN}^- = \text{IN}^+ \leq 5\text{V}$	● 130	140		dB
Input Common Mode Rejection 60Hz $\pm 2\%$ (LTC2411)	$2.5\text{V} \leq \text{REF}^+ \leq V_{\text{CC}}$ , $\text{REF}^- = \text{GND}$ , $\text{GND} \leq \text{IN}^- = \text{IN}^+ \leq 5\text{V}$ , (Note 7)	● 140			dB
Input Common Mode Rejection 50Hz $\pm 2\%$ (LTC2411)	$2.5\text{V} \leq \text{REF}^+ \leq V_{\text{CC}}$ , $\text{REF}^- = \text{GND}$ , $\text{GND} \leq \text{IN}^- = \text{IN}^+ \leq 5\text{V}$ , (Note 8)	● 140			dB
Input Common Mode Rejection 49Hz to 61.2Hz (LTC2411-1)	$2.5\text{V} < \text{REF}^+ < V_{\text{CC}}$ , $\text{REF}^- = \text{GND}$ , $\text{GND} < \text{IN}^- = \text{IN}^+ < V_{\text{CC}}$ (Note 15)	● 140			dB
Input Normal Mode Rejection 60Hz $\pm 2\%$ (LTC2411)	(Note 7)	● 110	140		dB
Input Normal Mode Rejection 50Hz $\pm 2\%$ (LTC2411)	(Note 8)	● 110	140		dB
Input Normal Mode Rejection 49Hz to 61.2Hz (LTC2411-1)	(Note 15)	● 87			dB
Reference Common Mode Rejection DC	$2.5\text{V} \leq \text{REF}^+ \leq V_{\text{CC}}$ , $\text{GND} \leq \text{REF}^- \leq 2.5\text{V}$ , $V_{\text{REF}} = 2.5\text{V}$ , $\text{IN}^- = \text{IN}^+ = \text{GND}$	● 130	140		dB
Power Supply Rejection, DC	$\text{REF}^+ = 2.5\text{V}$ , $\text{REF}^- = \text{GND}$ , $\text{IN}^- = \text{IN}^+ = \text{GND}$		110		dB
Power Supply Rejection, 60Hz $\pm 2\%$ (LTC2411)	$\text{REF}^+ = 2.5\text{V}$ , $\text{REF}^- = \text{GND}$ , $\text{IN}^- = \text{IN}^+ = \text{GND}$ , (Note 7)		120		dB
Power Supply Rejection, 50Hz $\pm 2\%$ (LTC2411)	$\text{REF}^+ = 2.5\text{V}$ , $\text{REF}^- = \text{GND}$ , $\text{IN}^- = \text{IN}^+ = \text{GND}$ , (Note 8)		120		dB
Power Supply Rejection, 49Hz to 61.2Hz (LTC2411-1)	$\text{REF}^+ = 2.5\text{V}$ , $\text{REF}^- = \text{GND}$ , $\text{IN}^- = \text{IN}^+ = \text{GND}$ , (Note 15)		120		dB

## ANALOG INPUT AND REFERENCE

The ● denotes the specifications which apply over the full operating temperature range, otherwise specifications are at  $T_A = 25^\circ\text{C}$ . (Note 3)

SYMBOL	PARAMETER	CONDITIONS	MIN	TYP	MAX	UNITS
$\text{IN}^+$	Absolute/Common Mode $\text{IN}^+$ Voltage	●	$\text{GND} - 0.3\text{V}$		$V_{\text{CC}} + 0.3\text{V}$	V
$\text{IN}^-$	Absolute/Common Mode $\text{IN}^-$ Voltage	●	$\text{GND} - 0.3\text{V}$		$V_{\text{CC}} + 0.3\text{V}$	V
$V_{\text{IN}}$	Input Differential Voltage Range ( $\text{IN}^+ - \text{IN}^-$ )	●	$-V_{\text{REF}}/2$		$V_{\text{REF}}/2$	V
$\text{REF}^+$	Absolute/Common Mode $\text{REF}^+$ Voltage	●	0.1		$V_{\text{CC}}$	V
$\text{REF}^-$	Absolute/Common Mode $\text{REF}^-$ Voltage	●	GND		$V_{\text{CC}} - 0.1\text{V}$	V
$V_{\text{REF}}$	Reference Differential Voltage Range ( $\text{REF}^+ - \text{REF}^-$ )	●	0.1		$V_{\text{CC}}$	V

2411fa

# LTC2411/LTC2411-1

## ANALOG INPUT AND REFERENCE

The ● denotes the specifications which apply over the full operating temperature range, otherwise specifications are at  $T_A = 25^\circ\text{C}$ . (Note 3)

SYMBOL	PARAMETER	CONDITIONS		MIN	TYP	MAX	UNITS
$C_S$ (IN <sup>+</sup> )	IN <sup>+</sup> Sampling Capacitance				6		pF
$C_S$ (IN <sup>-</sup> )	IN <sup>-</sup> Sampling Capacitance				6		pF
$C_S$ (REF <sup>+</sup> )	REF <sup>+</sup> Sampling Capacitance				6		pF
$C_S$ (REF <sup>-</sup> )	REF <sup>-</sup> Sampling Capacitance				6		pF
$I_{DC\_LEAK}$ (IN <sup>+</sup> )	IN <sup>+</sup> DC Leakage Current	$\overline{CS} = V_{CC} = 5.5V$ , IN <sup>+</sup> = GND	●	-10	1	10	nA
$I_{DC\_LEAK}$ (IN <sup>-</sup> )	IN <sup>-</sup> DC Leakage Current	$\overline{CS} = V_{CC} = 5.5V$ , IN <sup>-</sup> = GND	●	-10	1	10	nA
$I_{DC\_LEAK}$ (REF <sup>+</sup> )	REF <sup>+</sup> DC Leakage Current	$\overline{CS} = V_{CC} = 5.5V$ , REF <sup>+</sup> = 5V	●	-10	1	10	nA
$I_{DC\_LEAK}$ (REF <sup>-</sup> )	REF <sup>-</sup> DC Leakage Current	$\overline{CS} = V_{CC} = 5.5V$ , REF <sup>-</sup> = GND	●	-10	1	10	nA

## DIGITAL INPUTS AND DIGITAL OUTPUTS

The ● denotes the specifications which apply over the full operating temperature range, otherwise specifications are at  $T_A = 25^\circ\text{C}$ . (Note 3)

SYMBOL	PARAMETER	CONDITIONS		MIN	TYP	MAX	UNITS
$V_{IH}$	High Level Input Voltage $\overline{CS}$ , $F_0$	$2.7V \leq V_{CC} \leq 5.5V$ $2.7V \leq V_{CC} \leq 3.3V$	●	2.5 2.0			V V
$V_{IL}$	Low Level Input Voltage $\overline{CS}$ , $F_0$	$4.5V \leq V_{CC} \leq 5.5V$ $2.7V \leq V_{CC} \leq 5.5V$	●			0.8 0.6	V V
$V_{IH}$	High Level Input Voltage SCK	$2.7V \leq V_{CC} \leq 5.5V$ (Note 9) $2.7V \leq V_{CC} \leq 3.3V$ (Note 9)	●	2.5 2.0			V V
$V_{IL}$	Low Level Input Voltage SCK	$4.5V \leq V_{CC} \leq 5.5V$ (Note 9) $2.7V \leq V_{CC} \leq 5.5V$ (Note 9)	●			0.8 0.6	V V
$I_{IN}$	Digital Input Current $\overline{CS}$ , $F_0$	$0V \leq V_{IN} \leq V_{CC}$	●	-10		10	$\mu\text{A}$
$I_{IN}$	Digital Input Current SCK	$0V \leq V_{IN} \leq V_{CC}$ (Note 9)	●	-10		10	$\mu\text{A}$
$C_{IN}$	Digital Input Capacitance $\overline{CS}$ , $F_0$				10		pF
$C_{IN}$	Digital Input Capacitance SCK	(Note 9)			10		pF
$V_{OH}$	High Level Output Voltage SDO	$I_O = -800\mu\text{A}$	●	$V_{CC} - 0.5V$			V V
$V_{OL}$	Low Level Output Voltage SDO	$I_O = 1.6\text{mA}$	●			0.4	V V
$V_{OH}$	High Level Output Voltage SCK	$I_O = -800\mu\text{A}$ (Note 10)	●	$V_{CC} - 0.5V$			V V
$V_{OL}$	Low Level Output Voltage SCK	$I_O = 1.6\text{mA}$ (Note 10)	●			0.4	V V
$I_{OZ}$	Hi-Z Output Leakage SDO		●	-10		10	$\mu\text{A}$

## POWER REQUIREMENTS

The ● denotes the specifications which apply over the full operating temperature range, otherwise specifications are at  $T_A = 25^\circ\text{C}$ . (Note 3)

SYMBOL	PARAMETER	CONDITIONS		MIN	TYP	MAX	UNITS
$V_{CC}$	Supply Voltage		●	2.7		5.5	V
$I_{CC}$	Supply Current						
	Conversion Mode	$\overline{CS} = 0V$ (Note 12)	●		200	300	$\mu\text{A}$
	Sleep Mode	$\overline{CS} = V_{CC}$ (Note 12)	●		4	10	$\mu\text{A}$
	Sleep Mode	$\overline{CS} = V_{CC}$ , $2.7V \leq V_{CC} \leq 3.3V$ (Note 12)			2		$\mu\text{A}$

2411fa

## TIMING CHARACTERISTICS

The ● denotes the specifications which apply over the full operating temperature range, otherwise specifications are at  $T_A = 25^\circ\text{C}$ . (Note 3)

SYMBOL	PARAMETER	CONDITIONS	MIN	TYP	MAX	UNITS	
$f_{\text{EOSC}}$	External Oscillator Frequency Range	●	2.56		500	kHz	
$t_{\text{HEO}}$	External Oscillator High Period	●	0.25		390	$\mu\text{s}$	
$t_{\text{LEO}}$	External Oscillator Low Period	●	0.25		390	$\mu\text{s}$	
$t_{\text{CONV}}$	Conversion Time	$F_0 = 0\text{V}$ (LTC2411)	●	130.86	133.53	136.20	ms
		$F_0 = V_{\text{CC}}$ (LTC2411)	●	157.03	160.23	163.44	ms
		$F_0 = 0\text{V}$ (LTC2411-1)	●	143.78	146.71	149.64	ms
		External Oscillator (Note 11)	●	20510/ $f_{\text{EOSC}}$ (in kHz)			ms
$f_{\text{ISCK}}$	Internal SCK Frequency	Internal Oscillator (LTC2411) (Note 10)		19.2		kHz	
		Internal Oscillator (LTC2411-1) (Note 10)		17.5		kHz	
		External Oscillator (Notes 10, 11)		$f_{\text{EOSC}}/8$		kHz	
$D_{\text{ISCK}}$	Internal SCK Duty Cycle	(Note 10)	●	45	55	%	
$f_{\text{ESCK}}$	External SCK Frequency Range	(Note 9)	●		2000	kHz	
$t_{\text{LESCK}}$	External SCK Low Period	(Note 9)	●	250		ns	
$t_{\text{HESCK}}$	External SCK High Period	(Note 9)	●	250		ns	
$t_{\text{DOUT\_ISCK}}$	Internal SCK 32-Bit Data Output Time	Internal Oscillator (LTC2411) (Notes 10, 12)	●	1.64	1.67	1.70	ms
		Internal Oscillator (LTC2411-1) (Notes 10, 12)	●	1.80	1.83	1.86	ms
		External Oscillator (Notes 10, 11)	●	$256/f_{\text{EOSC}}$ (in kHz)			ms
$t_{\text{DOUT\_ESCK}}$	External SCK 32-Bit Data Output Time	(Note 9)	●	$32/f_{\text{ESCK}}$ (in kHz)		ms	
$t_1$	$\overline{\text{CS}} \downarrow$ to SDO Low Z		●	0	200	ns	
$t_2$	$\overline{\text{CS}} \uparrow$ to SDO High Z		●	0	200	ns	
$t_3$	$\overline{\text{CS}} \downarrow$ to SCK $\downarrow$	(Note 10)	●	0	200	ns	
$t_4$	$\overline{\text{CS}} \downarrow$ to SCK $\uparrow$	(Note 9)	●	50		ns	
$t_{\text{QMAX}}$	SCK $\downarrow$ to SDO Valid		●		220	ns	
$t_{\text{QMIN}}$	SDO Hold After SCK $\downarrow$	(Note 5)	●	15		ns	
$t_5$	SCK Set-Up Before $\overline{\text{CS}} \downarrow$		●	50		ns	
$t_6$	SCK Hold After $\overline{\text{CS}} \downarrow$		●		50	ns	

**Note 1:** Stresses beyond those listed under Absolute Maximum Ratings may cause permanent damage to the device. Exposure to any Absolute Maximum Rating condition for extended periods may affect device reliability and lifetime.

**Note 2:** All voltage values are with respect to GND.

**Note 3:**  $V_{\text{CC}} = 2.7$  to  $5.5\text{V}$  unless otherwise specified.

$V_{\text{REF}} = \text{REF}^+ - \text{REF}^-$ ,  $V_{\text{REFCM}} = (\text{REF}^+ + \text{REF}^-)/2$ ;

$V_{\text{IN}} = \text{IN}^+ - \text{IN}^-$ ,  $V_{\text{INCM}} = (\text{IN}^+ + \text{IN}^-)/2$ .

**Note 4:**  $F_0$  pin tied to GND or to  $V_{\text{CC}}$  or to external conversion clock source with  $f_{\text{EOSC}} = 153600\text{Hz}$  unless otherwise specified.

**Note 5:** Guaranteed by design, not subject to test.

**Note 6:** Integral nonlinearity is defined as the deviation of a code from a straight line passing through the actual endpoints of the transfer curve. The deviation is measured from the center of the quantization band.

**Note 7:**  $F_0 = 0\text{V}$  (internal oscillator) or  $f_{\text{EOSC}} = 153600\text{Hz} \pm 2\%$  (external oscillator).

**Note 8:**  $F_0 = V_{\text{CC}}$  (internal oscillator) or  $f_{\text{EOSC}} = 128000\text{Hz} \pm 2\%$  (external oscillator).

**Note 9:** The converter is in external SCK mode of operation such that the SCK pin is used as digital input. The frequency of the clock signal driving SCK during the data output is  $f_{\text{ESCK}}$  and is expressed in kHz.

**Note 10:** The converter is in internal SCK mode of operation such that the SCK pin is used as digital output. In this mode of operation the SCK pin has a total equivalent load capacitance  $C_{\text{LOAD}} = 20\text{pF}$ .

**Note 11:** The external oscillator is connected to the  $F_0$  pin. The external oscillator frequency,  $f_{\text{EOSC}}$ , is expressed in kHz.

**Note 12:** The converter uses the internal oscillator.

$F_0 = 0\text{V}$  or  $F_0 = V_{\text{CC}}$ .

**Note 13:** The output noise includes the contribution of the internal calibration operations.

**Note 14:** Guaranteed by design and test correlation.

**Note 15:**  $F_0 = 0\text{V}$  (internal oscillator) or  $f_{\text{EOSC}} = 139800\text{Hz} \pm 2\%$  (external oscillator).

## TYPICAL PERFORMANCE CHARACTERISTICS

**Total Unadjusted Error**  
( $V_{CC} = 5V$ ,  $V_{REF} = 5V$ )

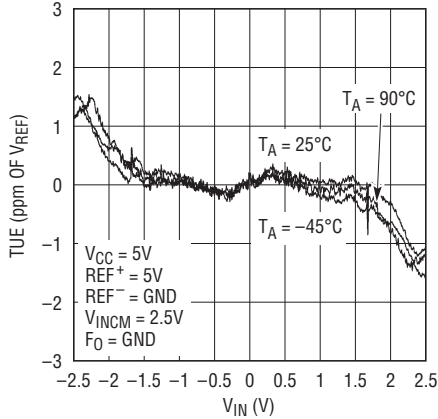

2411 G01

**Total Unadjusted Error**  
( $V_{CC} = 5V$ ,  $V_{REF} = 2.5V$ )

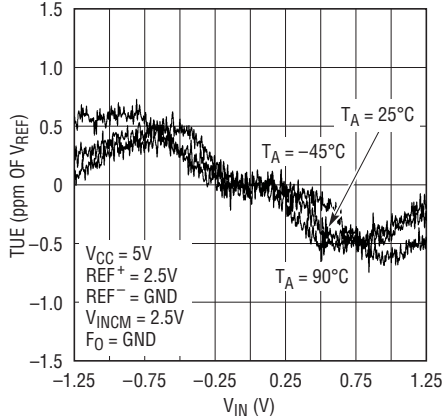

2411 G02

**Total Unadjusted Error**  
( $V_{CC} = 2.7V$ ,  $V_{REF} = 2.5V$ )

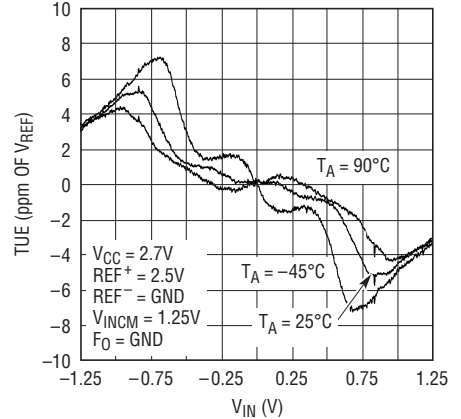

2411 G03

**Integral Nonlinearity**  
( $V_{CC} = 5V$ ,  $V_{REF} = 5V$ )

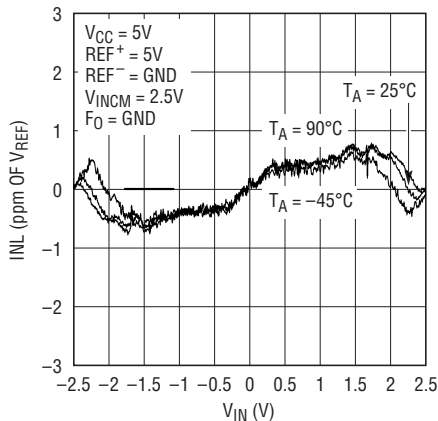

2411 G04

**Integral Nonlinearity**  
( $V_{CC} = 5V$ ,  $V_{REF} = 2.5V$ )

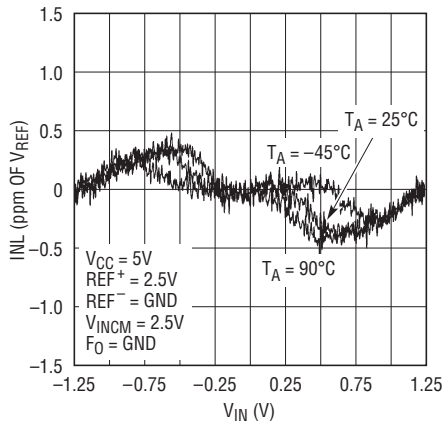

2411 G05

**Integral Nonlinearity**  
( $V_{CC} = 2.7V$ ,  $V_{REF} = 2.5V$ )

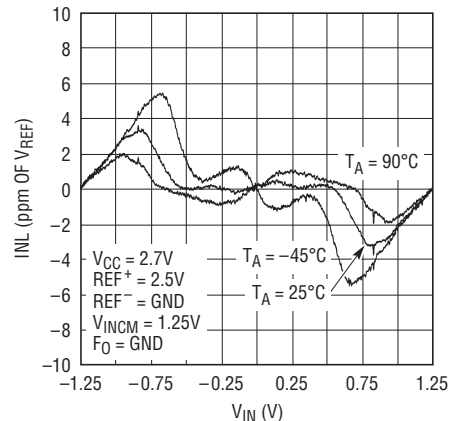

2411 G06

**Noise Histogram**

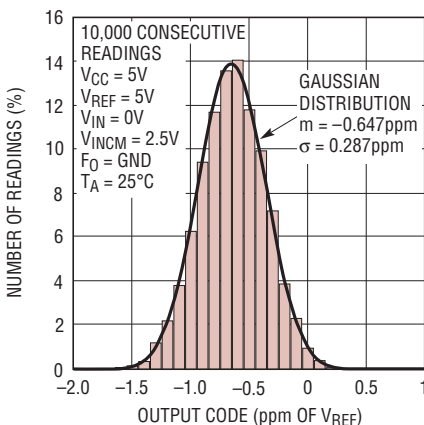

2411 G07

**Long Term ADC Readings**

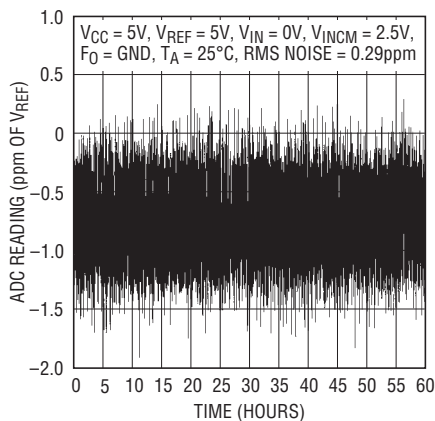

2411 G08

**RMS Noise vs Input Differential Voltage**

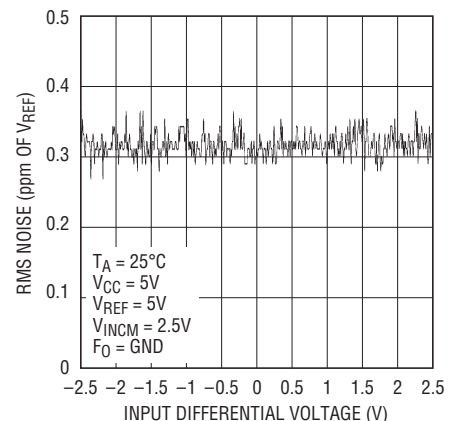

2411 G09

TYPICAL PERFORMANCE CHARACTERISTICS

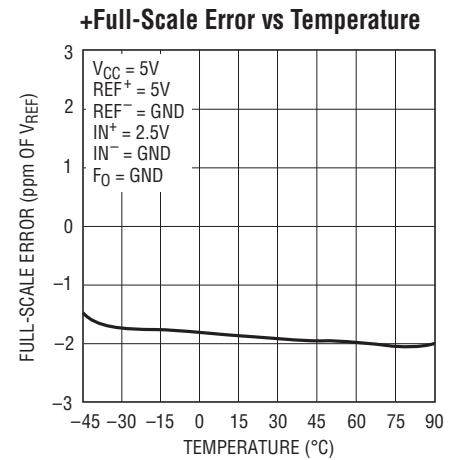
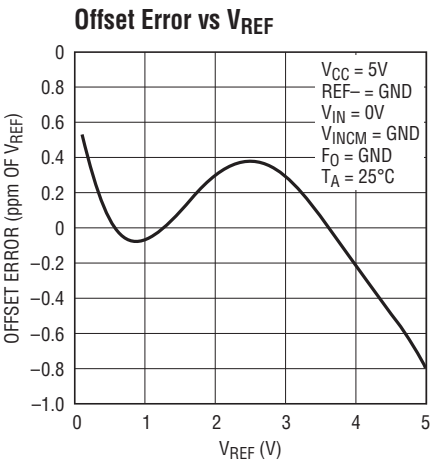
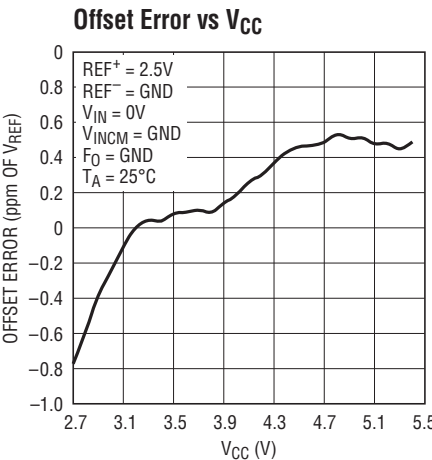
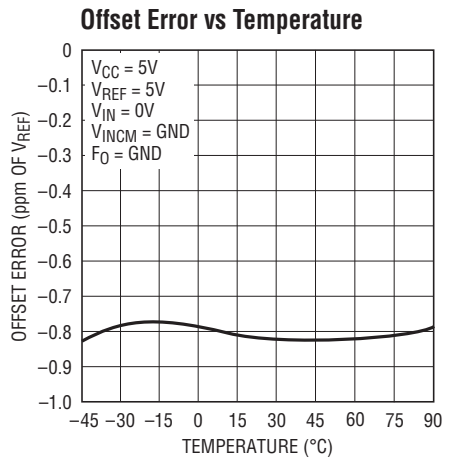
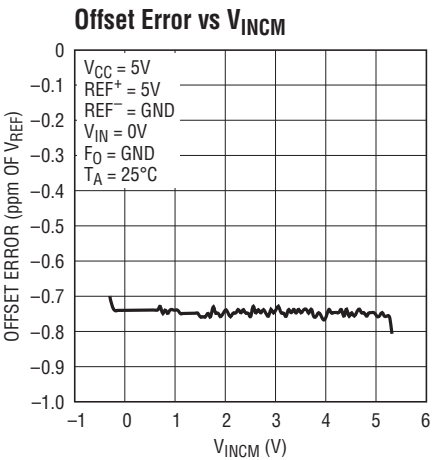
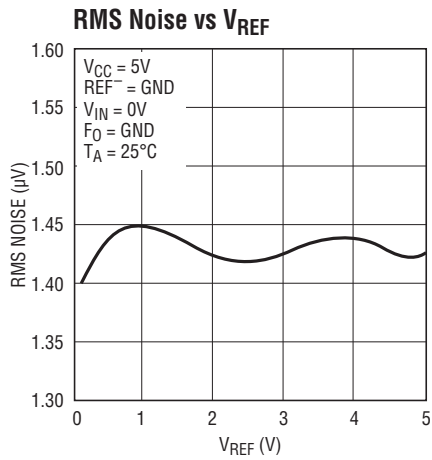
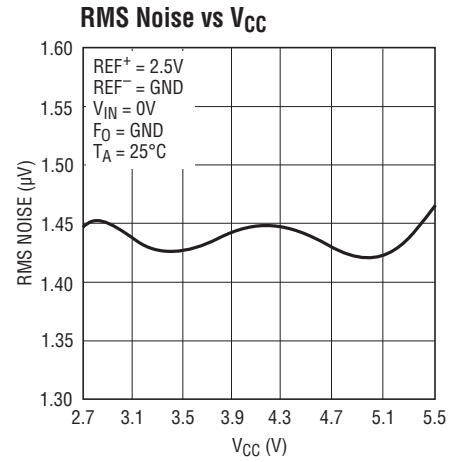
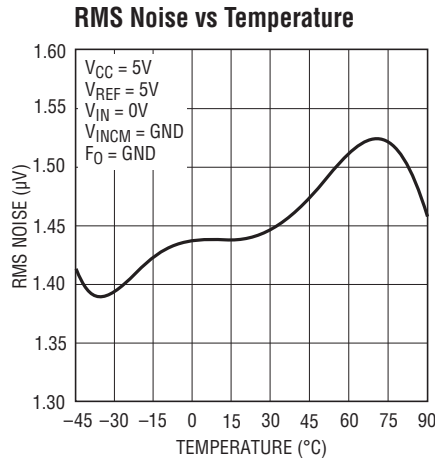
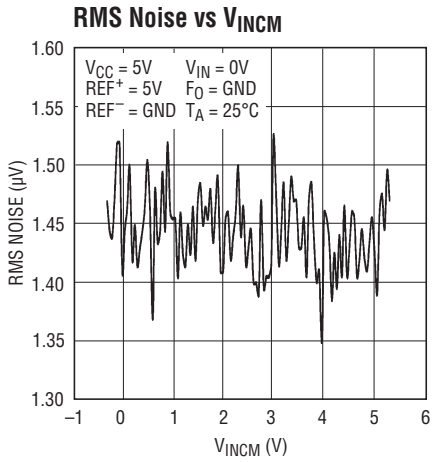

## TYPICAL PERFORMANCE CHARACTERISTICS

**+Full-Scale Error vs Temperature**

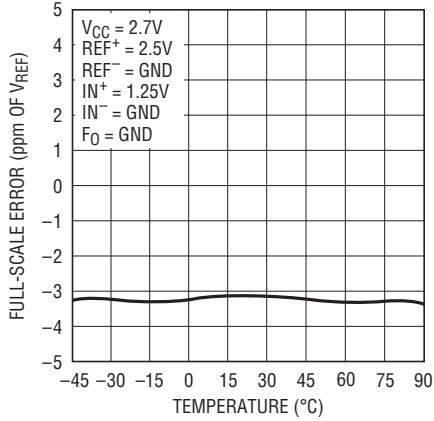

2411 G19

**-Full-Scale Error vs Temperature**

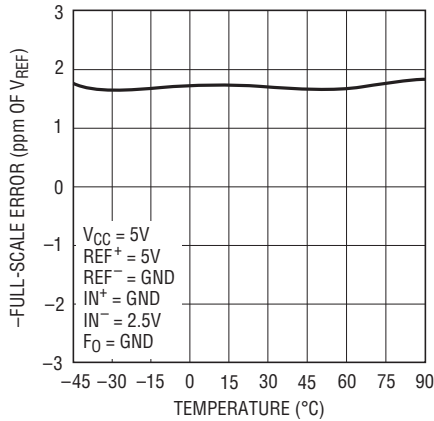

2411 G20

**-Full-Scale Error vs Temperature**

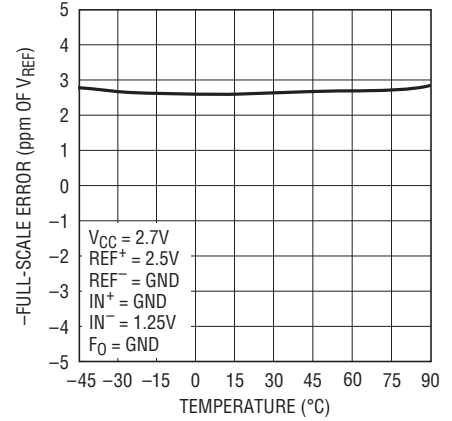

2411 G21

**PSRR vs Frequency at VCC (LTC2411)**

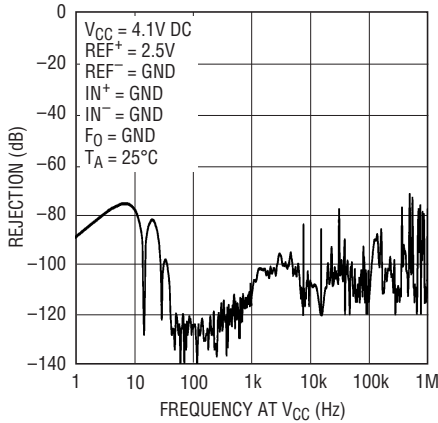

2411 G22

**PSRR vs Frequency at VCC (LTC2411)**

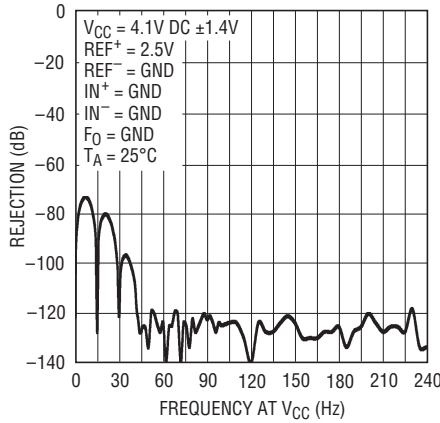

2411 G23

**PSRR vs Frequency at VCC (LTC2411)**

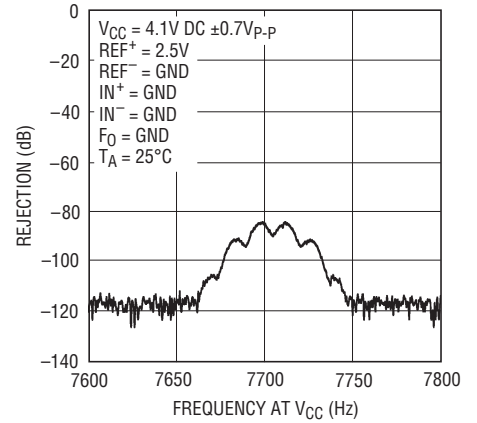

2411 G24

**PSRR vs Frequency at VCC (LTC2411-1)**

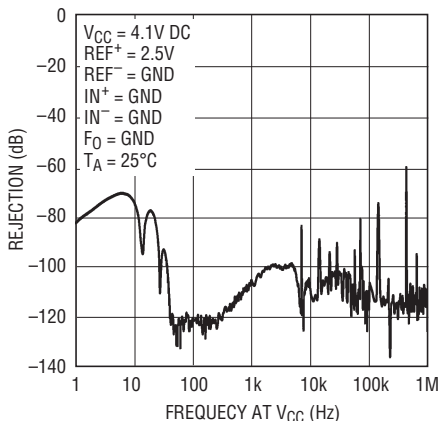

2411 G31

**PSRR vs Frequency at VCC (LTC2411-1)**

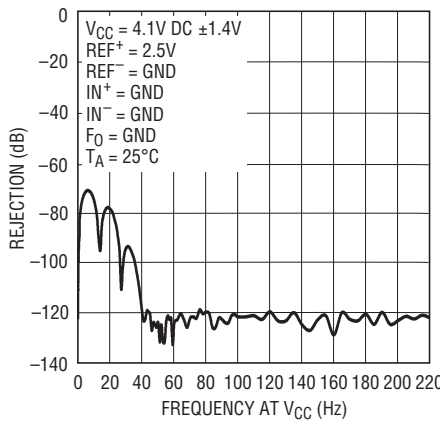

2411 G32

**PSRR vs Frequency at VCC (LTC2411-1)**

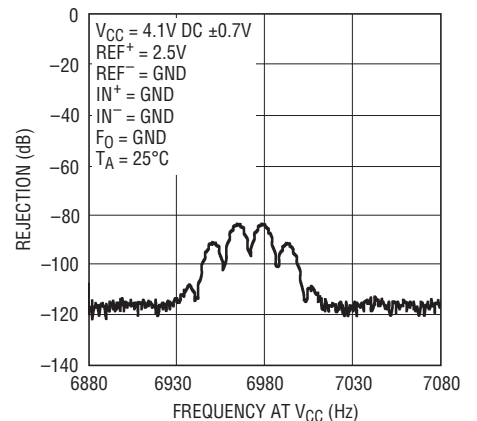

2411 G33

2411fa

# TYPICAL PERFORMANCE CHARACTERISTICS

**Conversion Current vs Temperature**

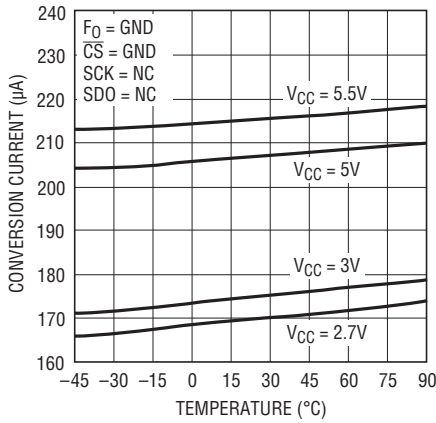

2411 G25

**Conversion Current vs Output Data Rate**

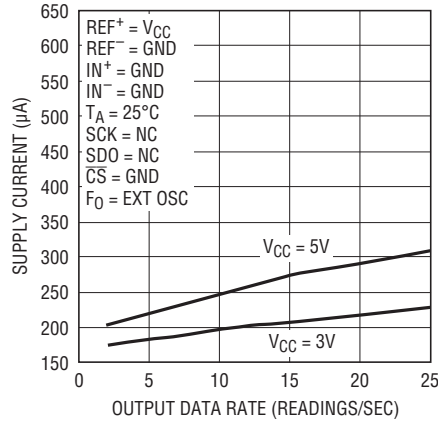

2411 G26

**Sleep Mode Current vs Temperature**

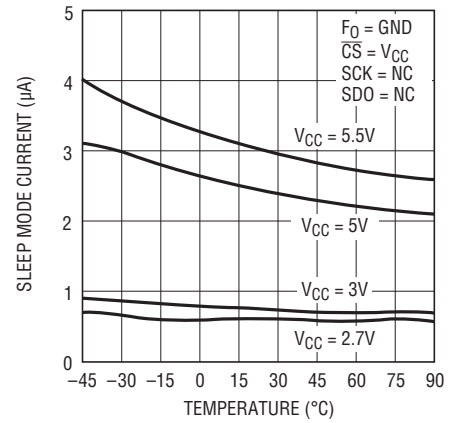

2411 G27

**Offset Error vs Output Data Rate**

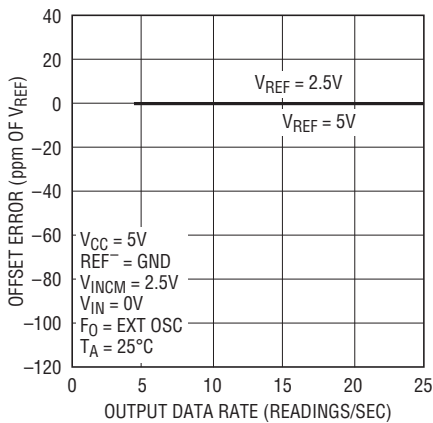

2411 G28

**Resolution (NOISE<sub>RMS</sub> ≤ 1LSB) vs Output Data Rate**

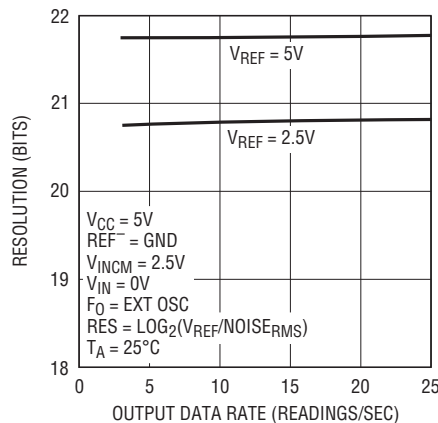

2411 G29

**Resolution (INL<sub>MAX</sub> ≤ 1LSB) vs Output Data Rate**

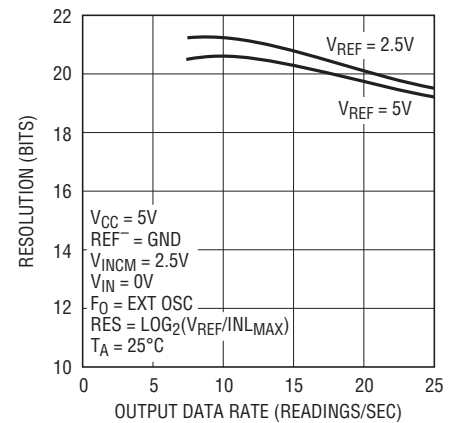

2411 G30

## PIN FUNCTIONS

**V<sub>CC</sub> (Pin 1):** Positive Supply Voltage. Bypass to GND (Pin 6) with a 10 $\mu$ F tantalum capacitor in parallel with 0.1 $\mu$ F ceramic capacitor as close to the part as possible.

**REF<sup>+</sup> (Pin 2), REF<sup>-</sup> (Pin 3):** Differential Reference Input. The voltage on these pins can have any value between GND and V<sub>CC</sub> as long as the reference positive input, REF<sup>+</sup>, is more positive than the reference negative input, REF<sup>-</sup>, by at least 0.1V.

**IN<sup>+</sup> (Pin 4), IN<sup>-</sup> (Pin 5):** Differential Analog Input. The voltage on these pins can have any value between GND – 0.3V and V<sub>CC</sub> + 0.3V. Within these limits, the converter bipolar input range ( $V_{IN} = IN^+ - IN^-$ ) extends from  $-0.5 \cdot (V_{REF})$  to  $0.5 \cdot (V_{REF})$ . Outside this input range, the converter produces unique overrange and underrange output codes.

**GND (Pin 6):** Ground. Connect this pin to a ground plane through a low impedance connection.

**$\overline{CS}$  (Pin 7):** Active LOW Digital Input. A LOW on this pin enables the SDO digital output and wakes up the ADC. Following each conversion the ADC automatically enters the Sleep mode and remains in this low power state as long as  $\overline{CS}$  is HIGH. A LOW-to-HIGH transition on  $\overline{CS}$  during the Data Output transfer aborts the data transfer and starts a new conversion.

**SDO (Pin 8):** Three-State Digital Output. During the Data Output period, this pin is used as the serial data output. When the chip select  $\overline{CS}$  is HIGH ( $\overline{CS} = V_{CC}$ ), the SDO pin

is in a high impedance state. During the Conversion and Sleep periods, this pin is used as the conversion status output. The conversion status can be observed by pulling  $\overline{CS}$  LOW.

**SCK (Pin 9):** Bidirectional Digital Clock Pin. In Internal Serial Clock Operation mode, SCK is used as the digital output for the internal serial interface clock during the Data Output period. In External Serial Clock Operation mode, SCK is used as the digital input for the external serial interface clock during the Data Output period. A weak internal pull-up is automatically activated in Internal Serial Clock Operation mode. The Serial Clock Operation mode is determined by the logic level applied to the SCK pin at power up or during the most recent falling edge of  $\overline{CS}$ .

**F<sub>0</sub> (Pin 10):** Frequency Control Pin. Digital input that controls the ADC's notch frequencies and conversion time. For the LTC2411, when the F<sub>0</sub> pin is connected to V<sub>CC</sub> (F<sub>0</sub> = V<sub>CC</sub>), the converter uses its internal oscillator and the digital filter first null is located at 50Hz. When the F<sub>0</sub> pin is connected to GND (F<sub>0</sub> = 0V), the converter uses its internal oscillator and the digital filter first null is located at 60Hz. For the LTC2411-1, the converter provides simultaneous 50Hz/60Hz rejection with the F<sub>0</sub> pin connected to GND. When F<sub>0</sub> is driven by an external clock signal with a frequency f<sub>EOSC</sub>, the converters use this signal as their system clock and the digital filter first null is located at a frequency f<sub>EOSC</sub>/2560.

## FUNCTIONAL BLOCK DIAGRAM

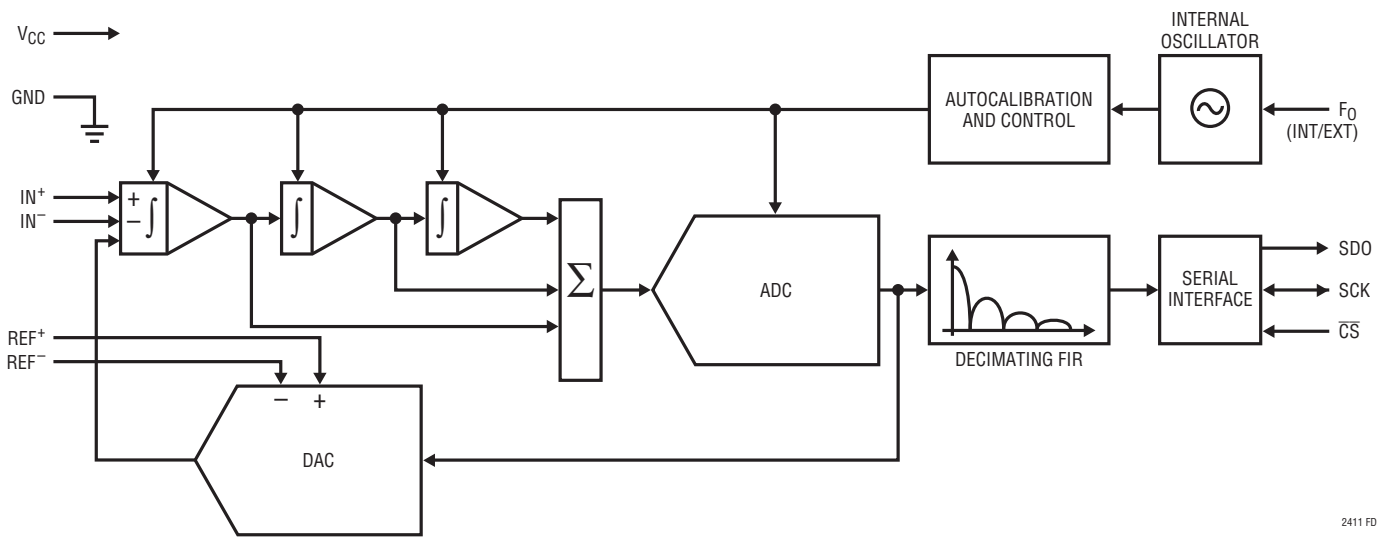

Figure 1

## TEST CIRCUIT



## APPLICATIONS INFORMATION

### CONVERTER OPERATION

#### Converter Operation Cycle

The LTC2411/LTC2411-1 are low power, delta-sigma analog-to-digital converters with an easy-to-use 3-wire serial interface (see Figure 1). Their operation is made up of three states. The converter operating cycle begins with the conversion, followed by the low power sleep state and ends with the data output (see Figure 2). The 3-wire interface consists of serial data output (SDO), serial clock (SCK) and chip select ( $\overline{CS}$ ).

Initially, the LTC2411/LTC2411-1 perform a conversion. Once the conversion is complete, the devices enter the sleep state. While in this sleep state, power consumption is reduced by an order of magnitude. The parts remain in the sleep state as long as  $\overline{CS}$  is HIGH. The conversion result is held indefinitely in a static shift register while the converter is in the sleep state.

Once  $\overline{CS}$  is pulled LOW, the devices begin outputting the conversion result. There is no latency in the conversion result. The data output corresponds to the conversion just performed. This result is shifted out on the serial data out pin (SDO) under the control of the serial clock (SCK). Data is updated on the falling edge of SCK allowing the user to reliably latch data on the rising edge of SCK (see Figure 3). The data output state is concluded once 32 bits are read out of the ADC or when  $\overline{CS}$  is brought HIGH. The devices automatically initiate a new conversion and the cycle repeats.

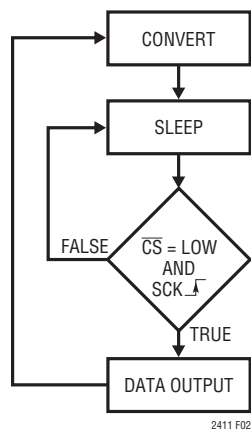

Figure 2. LTC2411/LTC2411-1 State Transition Diagram

Through timing control of the  $\overline{CS}$  and SCK pins, the LTC2411/LTC2411-1 offer several flexible modes of operation (internal or external SCK and free-running conversion modes). These various modes do not require programming configuration registers; moreover, they do not disturb the cyclic operation described above. These modes of operation are described in detail in the Serial Interface Timing Modes section.

#### Conversion Clock

A major advantage the delta-sigma converter offers over conventional type converters is an on-chip digital filter (commonly implemented as a Sinc or Comb filter). For high resolution, low frequency applications, this filter is typically designed to reject line frequencies of 50 or 60Hz plus their harmonics. The filter rejection performance is directly related to the accuracy of the converter system clock. The LTC2411/LTC2411-1 incorporate a highly accurate on-chip oscillator. This eliminates the need for external frequency setting components such as crystals or oscillators. Clocked by the on-chip oscillator, the LTC2411 achieves a minimum of 110dB rejection at the line frequency (50Hz or 60Hz  $\pm 2\%$ ) and the LTC2411-1 achieves a minimum of 87dB rejection over 49Hz to 61.2Hz.

#### Ease of Use

The LTC2411/LTC2411-1 data output has no latency, filter settling delay or redundant data associated with the conversion cycle. There is a one-to-one correspondence between the conversion and the output data. Therefore, multiplexing multiple analog voltages is easy.

The LTC2411/LTC2411-1 perform offset and full-scale calibrations in every conversion cycle. This calibration is transparent to the user and has no effect on the cyclic operation described above. The advantage of continuous calibration is extreme stability of offset and full-scale readings with respect to time, supply voltage change and temperature drift.

#### Power-Up Sequence

The LTC2411/LTC2411-1 automatically enter an internal reset state when the power supply voltage  $V_{CC}$  drops below approximately 1.9V. This feature guarantees the

## APPLICATIONS INFORMATION

integrity of the conversion result and of the serial interface mode selection. (See the 2-wire I/O sections in the Serial Interface Timing Modes section.)

When the  $V_{CC}$  voltage rises above this critical threshold, the converter creates an internal power-on-reset (POR) signal with a duration of approximately 1ms. The POR signal clears all internal registers. Following the POR signal, the LTC2411/LTC2411-1 start a normal conversion cycle and follow the succession of states described above. The first conversion result following POR is accurate within the specifications of the device if the power supply voltage is restored within the operating range (2.7V to 5.5V) before the end of the POR time interval.

### Reference Voltage Range

The LTC2411/LTC2411-1 accept a truly differential external reference voltage. The absolute/common mode voltage specification for the  $REF^+$  and  $REF^-$  pins covers the entire range from GND to  $V_{CC}$ . For correct converter operation, the  $REF^+$  pin must always be more positive than the  $REF^-$  pin.

The LTC2411/LTC2411-1 can accept a differential reference voltage from 0.1V to  $V_{CC}$ . The converter output noise is determined by the thermal noise of the front-end circuits, and, as such, its value in nanovolts is nearly constant with reference voltage. A decrease in reference voltage will not significantly improve the converter's effective resolution. On the other hand, a reduced reference voltage will improve the converter's overall INL performance. A reduced reference voltage will also improve the converter performance when operated with an external conversion clock (external  $F_0$  signal) at substantially higher output data rates.

### Input Voltage Range

The analog input is truly differential with an absolute/common mode range for the  $IN^+$  and  $IN^-$  input pins extending from  $GND - 0.3V$  to  $V_{CC} + 0.3V$ . Outside these limits, the ESD protection devices begin to turn on and the errors due to input leakage current increase rapidly. Within these limits, the LTC2411/LTC2411-1 convert the bipolar differential input signal,  $V_{IN} = IN^+ - IN^-$ , from  $-FS = -0.5 \cdot V_{REF}$  to  $+FS = 0.5 \cdot V_{REF}$  where  $V_{REF} = REF^+ - REF^-$ . Outside this range the converter indicates

the overrange or the underrange condition using distinct output codes.

Input signals applied to  $IN^+$  and  $IN^-$  pins may extend by 300mV below ground and above  $V_{CC}$ . In order to limit any fault current, resistors of up to 5k may be added in series with the  $IN^+$  and  $IN^-$  pins without affecting the performance of the device. In the physical layout, it is important to maintain the parasitic capacitance of the connection between these series resistors and the corresponding pins as low as possible; therefore, the resistors should be located as close as practical to the pins. In addition, series resistors will introduce a temperature dependent offset error due to the input leakage current. A 1nA input leakage current will develop a 1ppm offset error on a 5k resistor if  $V_{REF} = 5V$ . This error has a very strong temperature dependency.

### Output Data Format

The LTC2411/LTC2411-1 serial output data stream is 32 bits long. The first 3 bits represent status information indicating the sign and conversion state. The next 24 bits are the conversion result, MSB first. The remaining 5 bits are sub LSBs beyond the 24-bit level that may be included in averaging or discarded without loss of resolution. The third and fourth bits together are also used to indicate an underrange condition (the differential input voltage is below  $-FS$ ) or an overrange condition (the differential input voltage is above  $+FS$ ).

Bit 31 (first output bit) is the end of conversion (EOC) indicator. This bit is available at the SDO pin during the conversion and sleep states whenever the CS pin is LOW. This bit is HIGH during the conversion and goes LOW when the conversion is complete.

Bit 30 (second output bit) is a dummy bit (DMY) and is always LOW.

Bit 29 (third output bit) is the conversion result sign indicator (SIG). If  $V_{IN}$  is  $>0$ , this bit is HIGH. If  $V_{IN}$  is  $<0$ , this bit is LOW.

Bit 28 (fourth output bit) is the most significant bit (MSB) of the result. This bit in conjunction with Bit 29 also provides the underrange or overrange indication. If both Bit 29 and Bit 28 are HIGH, the differential input voltage is above  $+FS$ .

## APPLICATIONS INFORMATION

If both Bit 29 and Bit 28 are LOW, the differential input voltage is below  $-FS$ .

The function of these bits is summarized in Table 1.

**Table 1. LTC2411/LTC2411-1 Status Bits**

Input Range	Bit 31 EOC	Bit 30 DMY	Bit 29 SIG	Bit 28 MSB
$V_{IN} \geq 0.5 \cdot V_{REF}$	0	0	1	1
$0V \leq V_{IN} < 0.5 \cdot V_{REF}$	0	0	1	0
$-0.5 \cdot V_{REF} \leq V_{IN} < 0V$	0	0	0	1
$V_{IN} < -0.5 \cdot V_{REF}$	0	0	0	0

Bits 28-5 are the 24-bit conversion result MSB first.

Bit 5 is the least significant bit (LSB).

Bits 4-0 are sub LSBs below the 24-bit level. Bits 4-0 may be included in averaging or discarded without loss of resolution.

Data is shifted out of the SDO pin under control of the serial clock (SCK), see Figure 3. Whenever  $\overline{CS}$  is HIGH, SDO remains high impedance and any externally generated SCK clock pulses are ignored by the internal data out shift register.

In order to shift the conversion result out of the device,  $\overline{CS}$  must first be driven LOW. EOC is seen at the SDO pin of the device once  $\overline{CS}$  is pulled LOW.  $\overline{EOC}$  changes real time from HIGH to LOW at the completion of a conversion. This signal may be used as an interrupt for an external microcontroller. Bit 31 ( $\overline{EOC}$ ) can be captured on the first rising edge of SCK. Bit 30 is shifted out of the device on the first falling edge of SCK. The final data bit (Bit 0) is shifted out on the falling edge of the 31st SCK and may be latched on the rising edge of the 32nd SCK pulse. On the falling edge of the 32nd SCK pulse, SDO goes HIGH indicating the initiation of a new conversion cycle. This bit serves as  $\overline{EOC}$  (Bit 31) for the next conversion cycle. Table 2 summarizes the output data format.

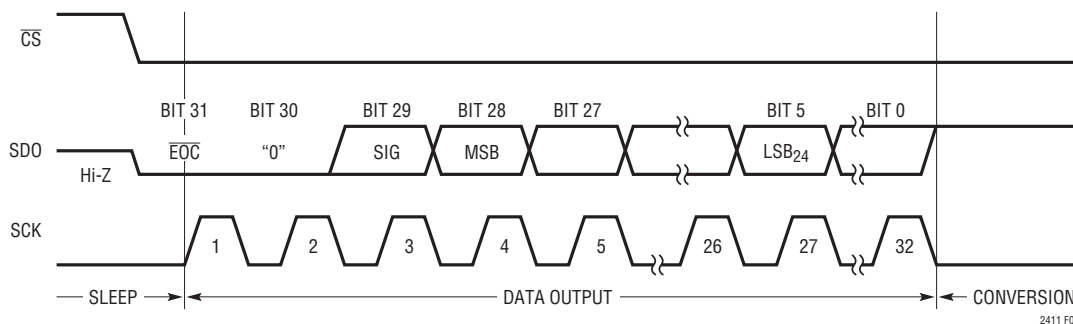

**Figure 3. Output Data Timing**

**Table 2. LTC2411/LTC2411-1 Output Data Format**

Differential Input Voltage $V_{IN}^*$	Bit 31 EOC	Bit 30 DMY	Bit 29 SIG	Bit 28 MSB	Bit 27	Bit 26	Bit 25	...	Bit 0
$V_{IN} \geq 0.5 \cdot V_{REF}^{**}$	0	0	1	1	0	0	0	...	0
$0.5 \cdot V_{REF}^{**} - 1LSB$	0	0	1	0	1	1	1	...	1
$0.25 \cdot V_{REF}^{**}$	0	0	1	0	1	0	0	...	0
$0.25 \cdot V_{REF}^{**} - 1LSB$	0	0	1	0	0	1	1	...	1
0	0	0	1	0	0	0	0	...	0
-1LSB	0	0	0	1	1	1	1	...	1
$-0.25 \cdot V_{REF}^{**}$	0	0	0	1	1	0	0	...	0
$-0.25 \cdot V_{REF}^{**} - 1LSB$	0	0	0	1	0	1	1	...	1
$-0.5 \cdot V_{REF}^{**}$	0	0	0	1	0	0	0	...	0
$V_{IN} < -0.5 \cdot V_{REF}^{**}$	0	0	0	0	1	1	1	...	1

\*The differential Input voltage  $V_{IN} = IN^+ - IN^-$ .

\*\*The differential reference voltage  $V_{REF} = REF^+ - REF^-$ .

## APPLICATIONS INFORMATION

As long as the voltage on the  $IN^+$  and  $IN^-$  pins is maintained within the  $-0.3V$  to  $(V_{CC} + 0.3V)$  absolute maximum operating range, a conversion result is generated for any differential input voltage  $V_{IN}$  from  $-FS = -0.5 \cdot V_{REF}$  to  $+FS = 0.5 \cdot V_{REF}$ . For differential input voltages greater than  $+FS$ , the conversion result is clamped to the value corresponding to the  $+FS + 1LSB$ . For differential input voltages below  $-FS$ , the conversion result is clamped to the value corresponding to  $-FS - 1LSB$ .

### Frequency Rejection Selection ( $F_0$ ) (LTC2411 Only)

The LTC2411 internal oscillator provides better than 110dB normal mode rejection at the line frequency and all its harmonics for 50Hz  $\pm 2\%$  or 60Hz  $\pm 2\%$ . For 60Hz rejection,  $F_0$  should be connected to GND while for 50Hz rejection the  $F_0$  pin should be connected to  $V_{CC}$ .

The selection of 50Hz or 60Hz rejection can also be made by driving  $F_0$  to an appropriate logic level. A selection change during the sleep or data output states will not disturb the converter operation. If the selection is made during the conversion state, the result of the conversion in progress may be outside specifications but the following conversions will not be affected.

When a fundamental rejection frequency different from 50Hz or 60Hz is required or when the converter must be synchronized with an outside source, the LTC2411 can operate with an external conversion clock. The converter automatically detects the presence of an external clock signal at the  $F_0$  pin and turns off the internal oscillator. The frequency  $f_{EOSC}$  of the external signal must be at least 2560Hz (1Hz notch frequency) to be detected. The external clock signal duty cycle is not significant as long as the minimum and maximum specifications for the high and low periods  $t_{HEO}$  and  $t_{LEO}$  are observed.

While operating with an external conversion clock of a frequency  $f_{EOSC}$ , the LTC2411 provides better than 110dB normal mode rejection in a frequency range  $f_{EOSC}/2560 \pm 4\%$  and its harmonics. The normal mode rejection as a function of the input frequency deviation from  $f_{EOSC}/2560$  is shown in Figure 4.

Whenever an external clock is not present at the  $F_0$  pin, the converter automatically activates its internal oscilla-

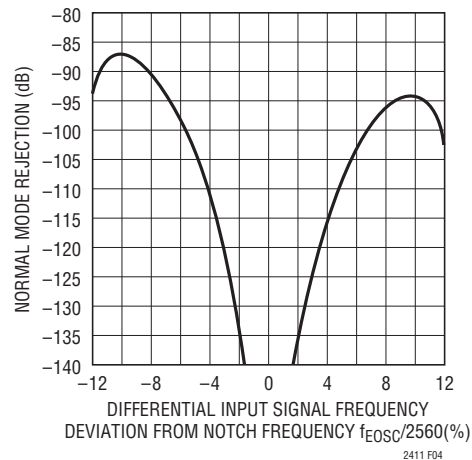

**Figure 4. LTC2411 Normal Mode Rejection When Using an External Oscillator of Frequency  $f_{EOSC}$**

tor and enters the Internal Conversion Clock mode. The LTC2411 operation will not be disturbed if the change of conversion clock source occurs during the sleep state or during the data output state while the converter uses an external serial clock. If the change occurs during the conversion state, the result of the conversion in progress may be outside specifications but the following conversions will not be affected. If the change occurs during the data output state and the converter is in the Internal SCK mode, the serial clock duty cycle may be affected but the serial data stream will remain valid.

Table 3 summarizes the duration of each state and the achievable output data rate as a function of  $F_0$ .

### Simultaneous Frequency Rejection (LTC2411-1 Only)

The LTC2411-1 internal oscillator provides better than 87dB normal mode rejection over the range of 49Hz to 61.2Hz. For this simultaneous 50/60Hz rejection,  $F_0$  should be connected to GND. The performance of the LTC2411-1 is the same as the LTC2411 when driven by an external conversion clock at  $F_0$  pin.

### Serial Interface pins

The LTC2411/LTC2411-1 transmit the conversion results and receive the start of conversion command through a synchronous 3-wire interface. During the conversion and sleep states, this interface can be used to assess the

## APPLICATIONS INFORMATION

**Table 3. LTC2411/LTC2411-1 State Duration**

State	Operating Mode		Duration
CONVERT	Internal Oscillator	F <sub>0</sub> = LOW (LTC2411) (60Hz Rejection)	133ms, Output Data Rate ≤ 7.5 Readings/s
		F <sub>0</sub> = HIGH (LTC2411) (50Hz Rejection)	160ms, Output Data Rate ≤ 6.2 Readings/s
		F <sub>0</sub> = LOW (LTC2411-1) (Simultaneous 50Hz/60Hz Rejection)	147ms, Output Data Rate ≤ 6.8 Readings/s
	External Oscillator	F <sub>0</sub> = External Oscillator with Frequency f <sub>EOSC</sub> kHz (f <sub>EOSC</sub> /2560 Rejection)	20510/f <sub>EOSC</sub> S, Output Data Rate ≤ f <sub>EOSC</sub> /20510 Readings/s
SLEEP			As Long As $\overline{CS}$ = HIGH Until $\overline{CS}$ = LOW and SCK $\downarrow$
DATA OUTPUT	Internal Serial Clock	F <sub>0</sub> = LOW/HIGH (LTC2411) (Internal Oscillator)	As Long As $\overline{CS}$ = LOW But Not Longer Than 1.67ms (32 SCK cycles)
		F <sub>0</sub> = LOW (LTC2411-1) (Internal Oscillator)	As Long As $\overline{CS}$ = LOW But Not Longer Than 1.83ms (32 SCK cycles)
		F <sub>0</sub> = External Oscillator with Frequency f <sub>EOSC</sub> kHz	As Long As $\overline{CS}$ = LOW But Not Longer Than 256/f <sub>EOSC</sub> ms (32 SCK cycles)
	External Serial Clock with Frequency f <sub>SCK</sub> kHz		As Long As $\overline{CS}$ = LOW But Not Longer Than 32/f <sub>SCK</sub> ms (32 SCK cycles)

converter status and during the data output state it is used to read the conversion result.

### Serial Clock Input/Output (SCK)

The serial clock signal present on SCK (Pin 9) is used to synchronize the data transfer. Each bit of data is shifted out the SDO pin on the falling edge of the serial clock.

In the Internal SCK mode of operation, the SCK pin is an output and the LTC2411/LTC2411-1 create their own serial clock by dividing the internal conversion clock by 8. In the External SCK mode of operation, the SCK pin is used as input. The internal or external SCK mode is selected on power-up and then reselected every time a HIGH-to-LOW transition is detected at the  $\overline{CS}$  pin. If SCK is HIGH or floating at power-up or during this transition, the converter enters the internal SCK mode. If SCK is LOW at power-up or during this transition, the converter enters the external SCK mode.

### Serial Data Output (SDO)

The serial data output pin, SDO (Pin 8), provides the result of the last conversion as a serial bit stream (MSB first) during the data output state. In addition, the SDO

pin is used as an end of conversion indicator during the conversion and sleep states.

When  $\overline{CS}$  (Pin 7) is HIGH, the SDO driver is switched to a high impedance state. This allows sharing the serial interface with other devices. If  $\overline{CS}$  is LOW during the convert or sleep state, SDO will output  $\overline{EOC}$ . If  $\overline{CS}$  is LOW during the conversion phase, the  $\overline{EOC}$  bit appears HIGH on the SDO pin. Once the conversion is complete,  $\overline{EOC}$  goes LOW. The device remains in the sleep state until the first rising edge of SCK occurs while  $\overline{CS}$  = LOW.

### Chip Select Input ( $\overline{CS}$ )

The active LOW chip select,  $\overline{CS}$  (Pin 7), is used to test the conversion status and to enable the data output transfer as described in the previous sections.

In addition, the  $\overline{CS}$  signal can be used to trigger a new conversion cycle before the entire serial data transfer has been completed. The LTC2411/LTC2411-1 will abort any serial data transfer in progress and start a new conversion cycle anytime a LOW-to-HIGH transition is detected at the  $\overline{CS}$  pin after the converter has entered the data output state (i.e., after the first rising edge of SCK occurs with  $\overline{CS}$  = LOW).

## APPLICATIONS INFORMATION

Table 4. LTC2411/LTC2411-1 Interface Timing Modes

Configuration	SCK Source	Conversion Cycle Control	Data Output Control	Connection and Waveforms
External SCK, Single Cycle Conversion	External	$\overline{CS}$ and SCK	$\overline{CS}$ and SCK	Figures 5, 6
External SCK, 2-Wire I/O	External	SCK	SCK	Figure 7
Internal SCK, Single Cycle Conversion	Internal	$\overline{CS} \downarrow$	$\overline{CS} \downarrow$	Figures 8, 9
Internal SCK, 2-Wire I/O, Continuous Conversion	Internal	Continuous	Internal	Figure 10

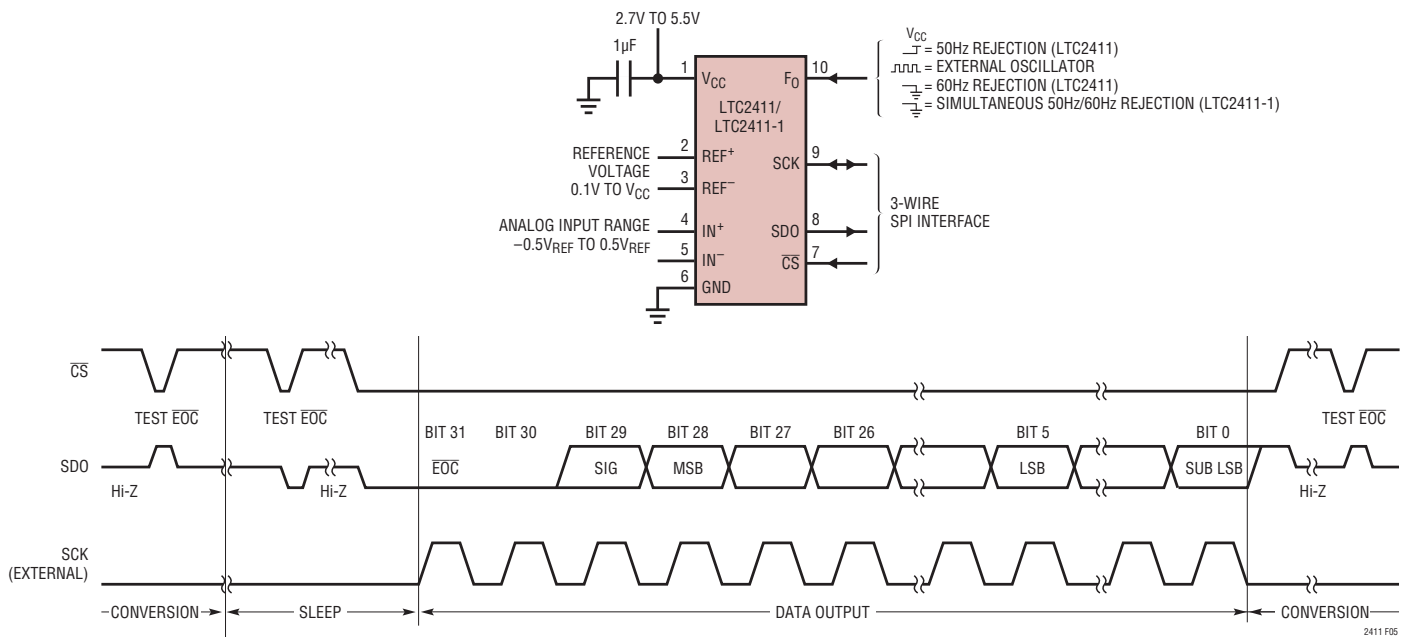

Figure 5. External Serial Clock, Single Cycle Operation

Finally,  $\overline{CS}$  can be used to control the free-running modes of operation, see Serial Interface Timing Modes section. Grounding  $\overline{CS}$  will force the ADC to continuously convert at the maximum output rate selected by  $F_0$ .

### SERIAL INTERFACE TIMING MODES

The LTC2411/LTC2411-1's 3-wire interface is SPI and MICROWIRE compatible. This interface offers several flexible modes of operation. These include internal/external serial clock, 2- or 3-wire I/O, single cycle conversion. The following sections describe each of these serial interface timing modes in detail. In all these cases, the converter can use the internal oscillator ( $F_0 = \text{LOW}$  or  $F_0 = \text{HIGH}$ ) or an external oscillator connected to the  $F_0$  pin. Refer to Table 4 for a summary.

### External Serial Clock, Single Cycle Operation (SPI/MICROWIRE Compatible)

This timing mode uses an external serial clock to shift out the conversion result and a  $\overline{CS}$  signal to monitor and control the state of the conversion cycle, see Figure 5.

The serial clock mode is selected on the falling edge of  $\overline{CS}$ . To select the external serial clock mode, the serial clock pin (SCK) must be LOW during each  $\overline{CS}$  falling edge.

The serial data output pin (SDO) is Hi-Z as long as  $\overline{CS}$  is HIGH. At any time during the conversion cycle,  $\overline{CS}$  may be pulled LOW in order to monitor the state of the converter. While  $\overline{CS}$  is pulled LOW,  $\overline{EOC}$  is output to the SDO pin.  $\overline{EOC} = 1$  while a conversion is in progress and  $\overline{EOC} = 0$  if the device is in the sleep state. Independent of  $\overline{CS}$ , the

## APPLICATIONS INFORMATION

device automatically enters the low power sleep state once the conversion is complete.

When the device is in the sleep state ( $\overline{EOC} = 0$ ), its conversion result is held in an internal static shift register. The device remains in the sleep state until the first rising edge of SCK is seen while  $\overline{CS}$  is LOW. Data is shifted out the SDO pin on each falling edge of SCK. This enables external circuitry to latch the output on the rising edge of SCK.  $\overline{EOC}$  can be latched on the first rising edge of SCK and the last bit of the conversion result can be latched on the 32nd rising edge of SCK. On the 32nd falling edge of SCK, the device begins a new conversion. SDO goes HIGH ( $\overline{EOC} = 1$ ) indicating a conversion is in progress.

At the conclusion of the data cycle,  $\overline{CS}$  may remain LOW and  $\overline{EOC}$  monitored as an end-of-conversion interrupt. Alternatively,  $\overline{CS}$  may be driven HIGH setting SDO to Hi-Z. As described above,  $\overline{CS}$  may be pulled LOW at any time in order to monitor the conversion status.

Typically,  $\overline{CS}$  remains LOW during the data output state. However, the data output state may be aborted by pulling  $\overline{CS}$  HIGH anytime between the first rising edge and the 32nd falling edge of SCK, see Figure 6. On the rising edge of  $\overline{CS}$ , the device aborts the data output state and immediately initiates a new conversion. This is useful for

systems not requiring all 32 bits of output data, aborting an invalid conversion cycle or synchronizing the start of a conversion.

### External Serial Clock, 2-Wire I/O

This timing mode utilizes a 2-wire serial I/O interface. The conversion result is shifted out of the device by an externally generated serial clock (SCK) signal, see Figure 7.  $\overline{CS}$  may be permanently tied to ground, simplifying the user interface or isolation barrier.

The external serial clock mode is selected at the end of the power-on reset (POR) cycle. The POR cycle is concluded approximately 1ms after  $V_{CC}$  exceeds 1.9V. The level applied to SCK at this time determines if SCK is internal or external. SCK must be driven LOW prior to the end of POR in order to enter the external serial clock timing mode.

Since  $\overline{CS}$  is tied LOW, the end-of-conversion ( $\overline{EOC}$ ) can be continuously monitored at the SDO pin during the convert and sleep states.  $\overline{EOC}$  may be used as an interrupt to an external controller indicating the conversion result is ready.  $\overline{EOC} = 1$  while the conversion is in progress and  $\overline{EOC} = 0$  once the conversion enters the low power sleep state. On the falling edge of  $\overline{EOC}$ , the conversion result is loaded into an internal static shift register. The device

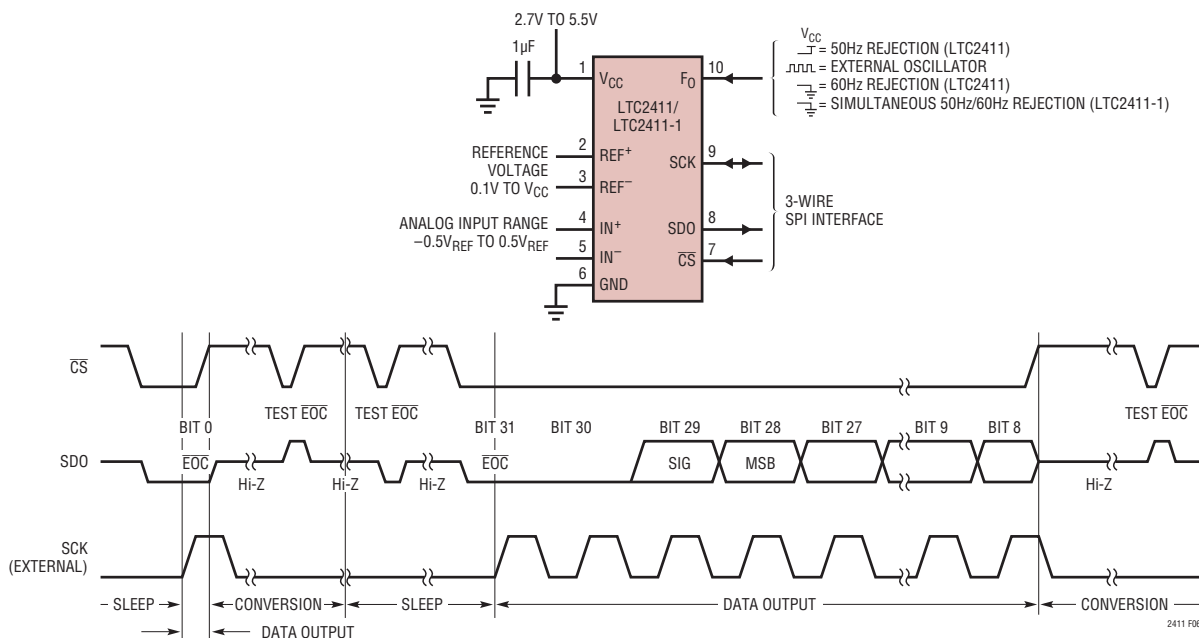

Figure 6. External Serial Clock, Reduced Data Output Length

2411fa

## APPLICATIONS INFORMATION

remains in the sleep state until the first rising edge of SCK. Data is shifted out the SDO pin on each falling edge of SCK enabling external circuitry to latch data on the rising edge of SCK. EOC can be latched on the first rising edge of SCK. On the 32nd falling edge of SCK, SDO goes HIGH ( $\overline{EOC} = 1$ ) indicating a new conversion has begun.

### Internal Serial Clock, Single Cycle Operation

This timing mode uses an internal serial clock to shift out the conversion result and a  $\overline{CS}$  signal to monitor and control the state of the conversion cycle, see Figure 8.

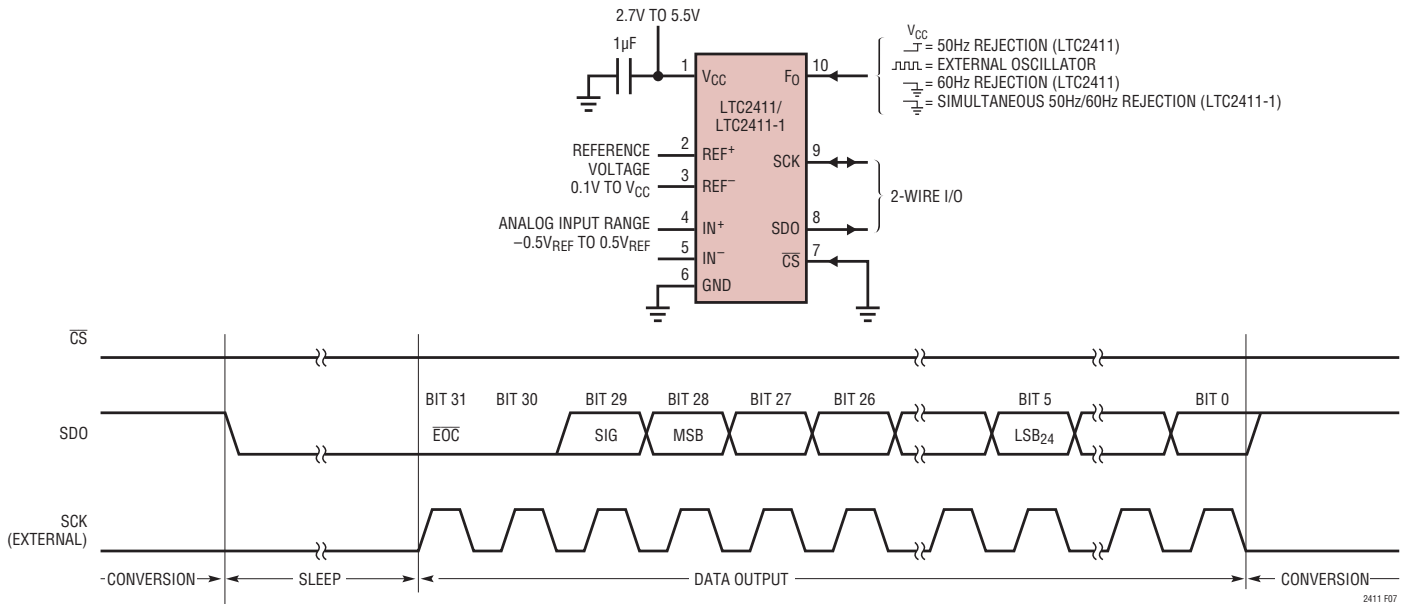

Figure 7. External Serial Clock,  $\overline{CS} = 0$  Operation

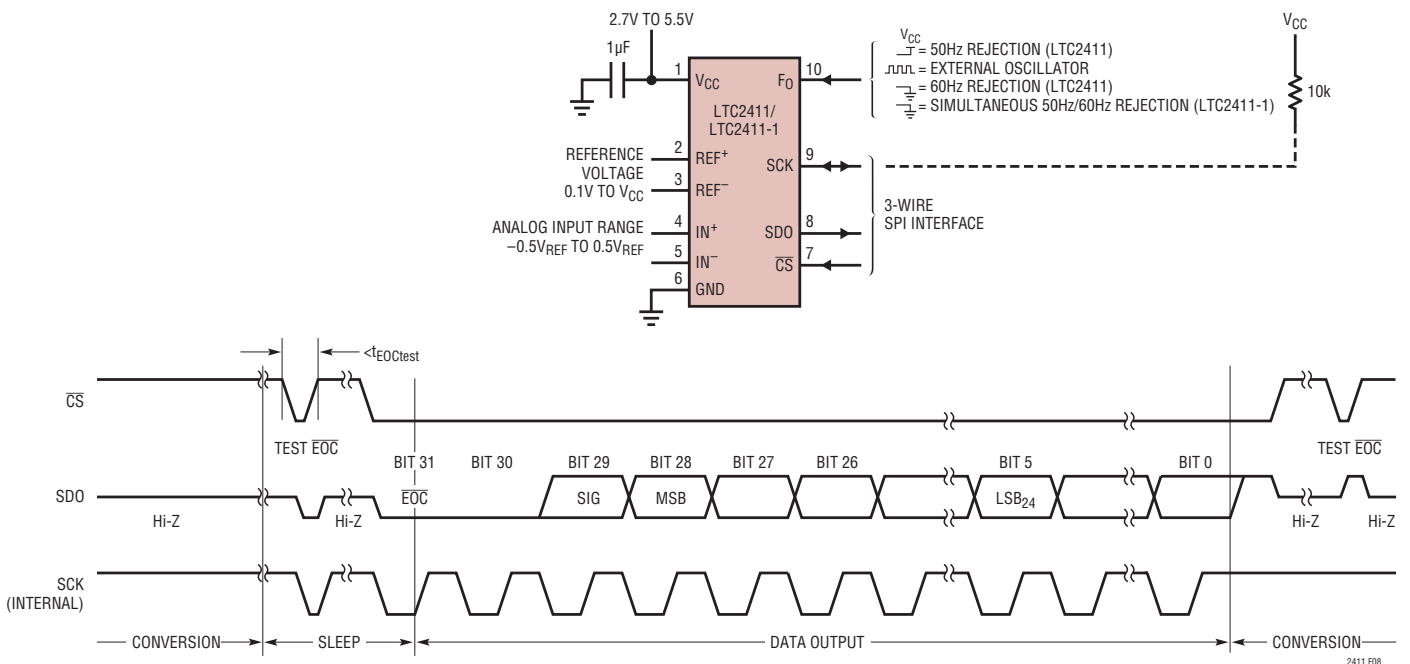

Figure 8. Internal Serial Clock, Single Cycle Operation

## APPLICATIONS INFORMATION

In order to select the internal serial clock timing mode, the serial clock pin (SCK) must be floating (Hi-Z) or pulled HIGH prior to the falling edge of  $\overline{CS}$ . The device will not enter the internal serial clock mode if SCK is driven LOW on the falling edge of  $\overline{CS}$ . An internal weak pull-up resistor is active on the SCK pin during the falling edge of  $\overline{CS}$ ; therefore, the internal serial clock timing mode is automatically selected if SCK is not externally driven.

The serial data output pin (SDO) is Hi-Z as long as  $\overline{CS}$  is HIGH. At any time during the conversion cycle,  $\overline{CS}$  may be pulled LOW in order to monitor the state of the converter. Once  $\overline{CS}$  is pulled LOW, SCK goes LOW and  $\overline{EOC}$  is output to the SDO pin.  $\overline{EOC} = 1$  while a conversion is in progress and  $\overline{EOC} = 0$  if the device is in the sleep state.

When testing  $\overline{EOC}$ , if the conversion is complete ( $\overline{EOC} = 0$ ), the device will exit the sleep state and enter the data output state if  $\overline{CS}$  remains LOW. In order to prevent the device from exiting the low power sleep state,  $\overline{CS}$  must be pulled HIGH before the first rising edge of SCK. In the internal SCK timing mode, SCK goes HIGH and the device begins outputting data at time  $t_{EOCtest}$  after the falling edge of  $\overline{CS}$  (if  $\overline{EOC} = 0$ ) or  $t_{EOCtest}$  after  $\overline{EOC}$  goes LOW (if  $\overline{CS}$  is LOW during the falling edge of  $\overline{EOC}$ ). The value of  $t_{EOCtest}$  is 23 $\mu$ s

if the device is using its internal oscillator for the LTC2411 ( $F_0 =$  logic LOW or HIGH) and 26 $\mu$ s for the LTC2411-1 ( $F_0 =$  logic LOW). If  $F_0$  is driven by an external oscillator of frequency  $f_{EOSC}$ , then  $t_{EOCtest}$  is  $3.6/f_{EOSC}$ . If  $\overline{CS}$  is pulled HIGH before time  $t_{EOCtest}$ , the device remains in the sleep state. The conversion result is held in the internal static shift register.

If  $\overline{CS}$  remains LOW longer than  $t_{EOCtest}$ , the first rising edge of SCK will occur and the conversion result is serially shifted out of the SDO pin. The data output cycle begins on this first rising edge of SCK and concludes after the 32nd rising edge. Data is shifted out the SDO pin on each falling edge of SCK. The internally generated serial clock is output to the SCK pin. This signal may be used to shift the conversion result into external circuitry.  $\overline{EOC}$  can be latched on the first rising edge of SCK and the last bit of the conversion result on the 32nd rising edge of SCK. After the 32nd rising edge, SDO goes HIGH ( $\overline{EOC} = 1$ ), SCK stays HIGH and a new conversion starts.

Typically,  $\overline{CS}$  remains LOW during the data output state. However, the data output state may be aborted by pulling  $\overline{CS}$  HIGH anytime between the first and 32nd rising edge of SCK, see Figure 9. On the rising edge of  $\overline{CS}$ , the device

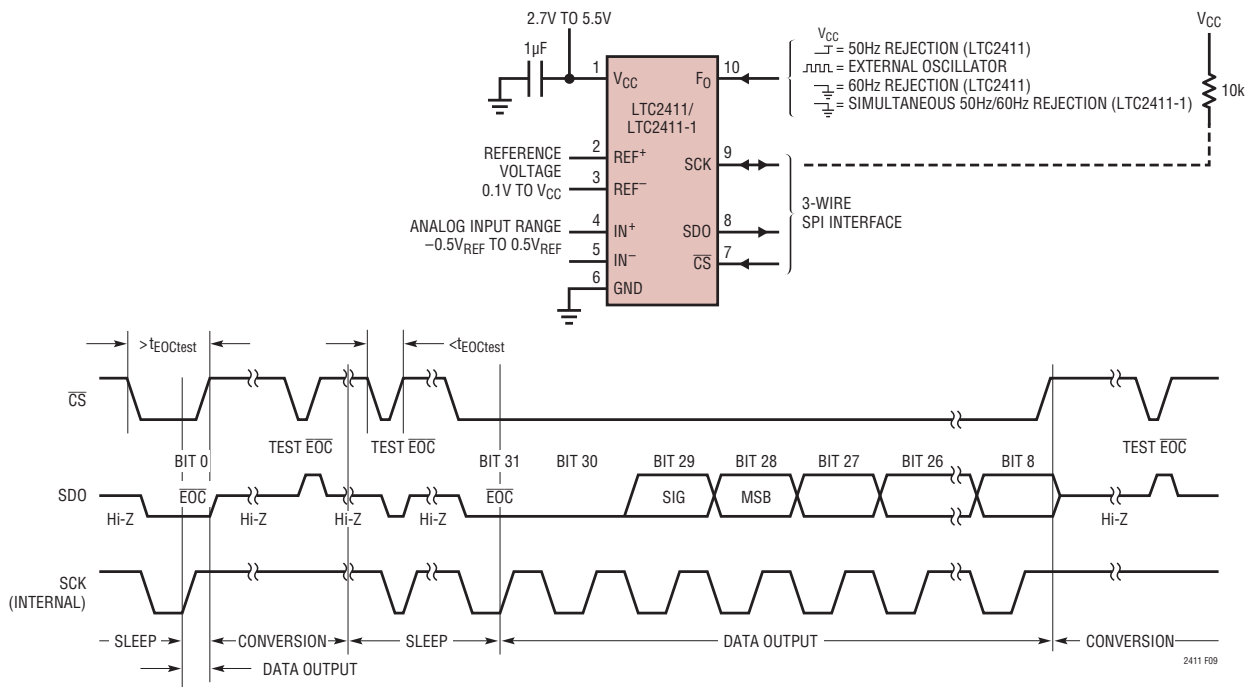

Figure 9. Internal Serial Clock, Reduced Data Output Length

## APPLICATIONS INFORMATION

aborts the data output state and immediately initiates a new conversion. This is useful for systems not requiring all 32 bits of output data, aborting an invalid conversion cycle, or synchronizing the start of a conversion. If  $\overline{CS}$  is pulled HIGH while the converter is driving SCK LOW, the internal pull-up is not available to restore SCK to a logic HIGH state. This will cause the device to exit the internal serial clock mode on the next falling edge of  $\overline{CS}$ . This can be avoided by adding an external 10k pull-up resistor to the SCK pin or by never pulling  $\overline{CS}$  HIGH when SCK is LOW.

Whenever SCK is LOW, the LTC2411/LTC2411-1's internal pull-up at pin SCK is disabled. Normally, SCK is not externally driven if the device is in the internal SCK timing mode. However, certain applications may require an external driver on SCK. If this driver goes Hi-Z after outputting a LOW signal, the LTC2411/LTC2411-1's internal pull-up remains disabled. Hence, SCK remains LOW. On the next falling edge of  $\overline{CS}$ , the device is switched to the external SCK timing mode. By adding an external 10k pull-up resistor to SCK, this pin goes HIGH once the external driver goes Hi-Z. On the next  $\overline{CS}$  falling edge, the device will remain in the internal SCK timing mode.

A similar situation may occur during the sleep state when  $\overline{CS}$  is pulsed HIGH-LOW-HIGH in order to test the conversion status. If the device is in the sleep state ( $\overline{EOC} = 0$ ), SCK will go LOW. Once  $\overline{CS}$  goes HIGH (within the time period defined above as  $t_{EOCtest}$ ), the internal pull-up is activated. For a heavy capacitive load on the SCK pin, the internal pull-up may not be adequate to return SCK to a HIGH level before  $\overline{CS}$  goes low again. This is not a concern under normal conditions where  $\overline{CS}$  remains LOW after detecting  $\overline{EOC} = 0$ . This situation is easily overcome by adding an external 10k pull-up resistor to the SCK pin.

### Internal Serial Clock, 2-Wire I/O, Continuous Conversion

This timing mode uses a 2-wire, all output (SCK and SDO) interface. The conversion result is shifted out of the device by an internally generated serial clock (SCK) signal, see Figure 10.  $\overline{CS}$  may be permanently tied to ground, simplifying the user interface or isolation barrier.

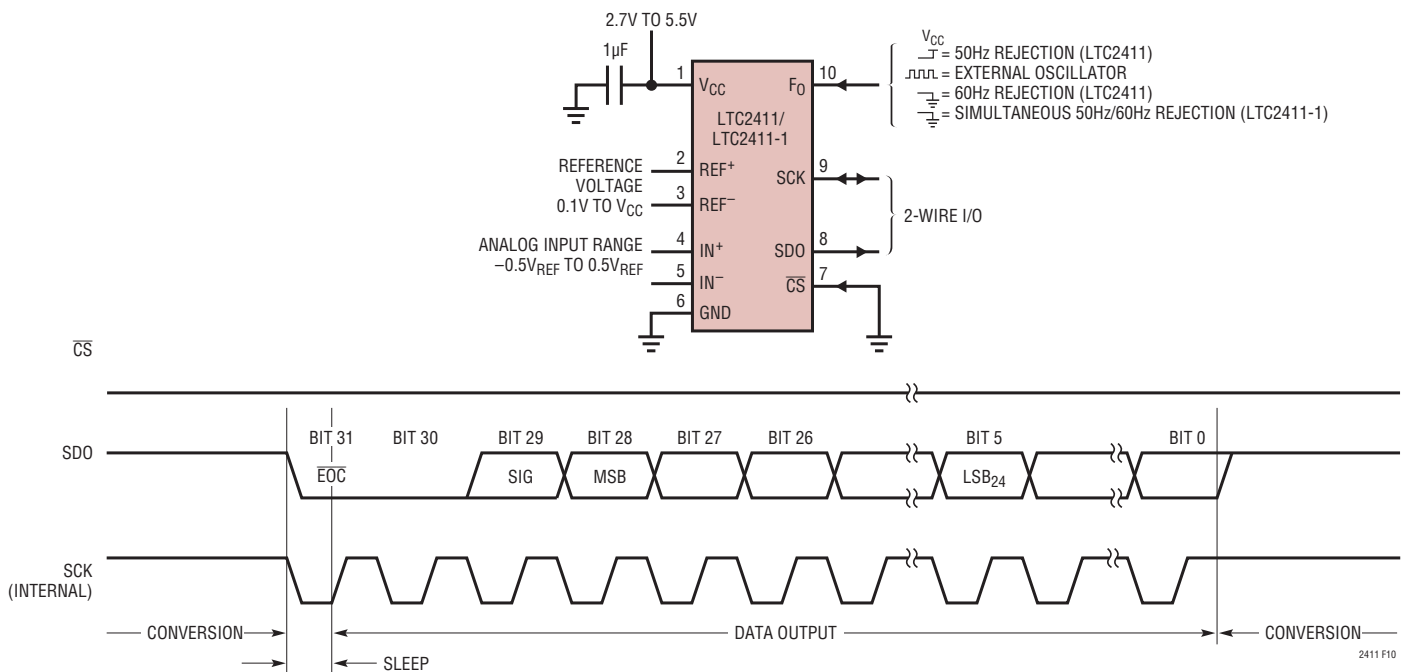

Figure 10. Internal Serial Clock,  $\overline{CS} = 0$  Continuous Operation

## APPLICATIONS INFORMATION

The internal serial clock mode is selected at the end of the power-on reset (POR) cycle. The POR cycle is concluded approximately 1ms after  $V_{CC}$  exceeds 1.9V. An internal weak pull-up is active during the POR cycle; therefore, the internal serial clock timing mode is automatically selected if SCK is not externally driven LOW (if SCK is loaded such that the internal pull-up cannot pull the pin HIGH, the external SCK mode will be selected).

During the conversion, the SCK and the serial data output pin (SDO) are HIGH ( $\overline{EOC} = 1$ ). Once the conversion is complete, SCK and SDO go LOW ( $\overline{EOC} = 0$ ) indicating the conversion has finished and the device has entered the low power sleep state. The part remains in the sleep state a minimum amount of time (1/2 the internal SCK period) then immediately begins outputting data. The data output cycle begins on the first rising edge of SCK and ends after the 32nd rising edge. Data is shifted out the SDO pin on each falling edge of SCK. The internally generated serial clock is output to the SCK pin. This signal may be used to shift the conversion result into external circuitry.  $\overline{EOC}$  can be latched on the first rising edge of SCK and the last bit of the conversion result can be latched on the 32nd rising edge of SCK. After the 32nd rising edge, SDO goes HIGH ( $\overline{EOC} = 1$ ) indicating a new conversion is in progress. SCK remains HIGH during the conversion.

### PRESERVING THE CONVERTER ACCURACY

The LTC2411/LTC2411-1 are designed to reduce as much as possible the conversion result sensitivity to device decoupling, PCB layout, anti-aliasing circuits, line frequency perturbations and so on. Nevertheless, in order to preserve the extreme accuracy capability of this part, some simple precautions are desirable.

### Digital Signal Levels

The LTC2411/LTC2411-1's digital interface is easy to use. Its digital inputs ( $F_0$ ,  $\overline{CS}$  and SCK in External SCK mode of operation) accept standard TTL/CMOS logic levels and the internal hysteresis receivers can tolerate edge rates as slow as 100 $\mu$ s. However, some considerations are required to take advantage of the exceptional accuracy and low supply current of this converter.

The digital output signals (SDO and SCK in Internal SCK mode of operation) are less of a concern because they are not generally active during the conversion state.

While a digital input signal is in the range 0.5V to ( $V_{CC} - 0.5V$ ), the CMOS input receiver draws additional current from the power supply. It should be noted that, when any one of the digital input signals ( $F_0$ ,  $\overline{CS}$  and SCK in External SCK mode of operation) is within this range, the LTC2411/LTC2411-1 power supply current may increase even if the signal in question is at a valid logic level. For micropower operation, it is recommended to drive all digital input signals to full CMOS levels [ $V_{IL} < 0.4V$  and  $V_{OH} > (V_{CC} - 0.4V)$ ].

During the conversion period, the undershoot and/or overshoot of a fast digital signal connected to the LTC2411/LTC2411-1 pins may severely disturb the analog to digital conversion process. Undershoot and overshoot can occur because of the impedance mismatch at the converter pin when the transition time of an external control signal is less than twice the propagation delay from the driver to LTC2411/LTC2411-1. For reference, on a regular FR-4 board, signal propagation velocity is approximately 183ps/inch for internal traces and 170ps/inch for surface traces. Thus, a driver generating a control signal with a minimum transition time of 1ns must be connected to the converter pin through a trace shorter than 2.5 inches. This problem becomes particularly difficult when shared control lines are used and multiple reflections may occur. The solution is to carefully terminate all transmission lines close to their characteristic impedance.

Parallel termination near the LTC2411/LTC2411-1 pin will eliminate this problem but will increase the driver power dissipation. A series resistor between 27 $\Omega$  and 56 $\Omega$  placed near the driver or near the LTC2411/LTC2411-1 pin will also eliminate this problem without additional power dissipation. The actual resistor value depends upon the trace impedance and connection topology.

An alternate solution is to reduce the edge rate of the control signals. It should be noted that using very slow edges will increase the converter power supply current during the transition time. The differential input and reference architecture reduce substantially the converter's sensitivity to ground currents.

## APPLICATIONS INFORMATION

Particular attention must be given to the connection of the  $F_0$  signal when the LTC2411/LTC2411-1 are used with an external conversion clock. This clock is active during the conversion time and the normal mode rejection provided by the internal digital filter is not very high at this frequency. A normal mode signal of this frequency at the converter reference terminals may result into DC gain and INL errors. A normal mode signal of this frequency at the converter input terminals may result into a DC offset error. Such perturbations may occur due to asymmetric capacitive coupling between the  $F_0$  signal trace and the converter input and/or reference connection traces. An immediate solution is to maintain maximum possible separation between the  $F_0$  signal trace and the input/reference signals. When the  $F_0$  signal is parallel terminated near the converter, substantial AC current is flowing in the loop formed by the  $F_0$  connection trace, the termination and the ground return path. Thus, perturbation signals may be inductively coupled into the converter input and/or reference. In this situation, the user must reduce to a minimum the loop area for the  $F_0$  signal as well as the loop area for the differential input and reference connections.

### Driving the Input and Reference

The input and reference pins of the LTC2411/LTC2411-1 converter are directly connected to a network of sampling capacitors. Depending upon the relation between the differential input voltage and the differential reference voltage, these capacitors are switching between these four pins transferring small amounts of charge in the process. A simplified equivalent circuit is shown in Figure 11.

For a simple approximation, the source impedance  $R_S$  driving an analog input pin ( $IN^+$ ,  $IN^-$ ,  $REF^+$  or  $REF^-$ ) can be considered to form, together with  $R_{SW}$  and  $C_{EQ}$  (see Figure 11), a first order passive network with a time constant  $\tau = (R_S + R_{SW}) \cdot C_{EQ}$ . The converter is able to sample the input signal with better than 1ppm accuracy if the sampling period is at least 14 times greater than the input circuit time constant  $\tau$ . The sampling process on the four input analog pins is quasi-independent so each time constant should be considered by itself and, under worst-case circumstances, the errors may add.

When using the internal oscillator ( $F_0 = \text{LOW}$  or  $\text{HIGH}$ ), the LTC2411 (LTC2411-1)'s front-end switched-capacitor network is clocked at 76800Hz (69900Hz) corresponding

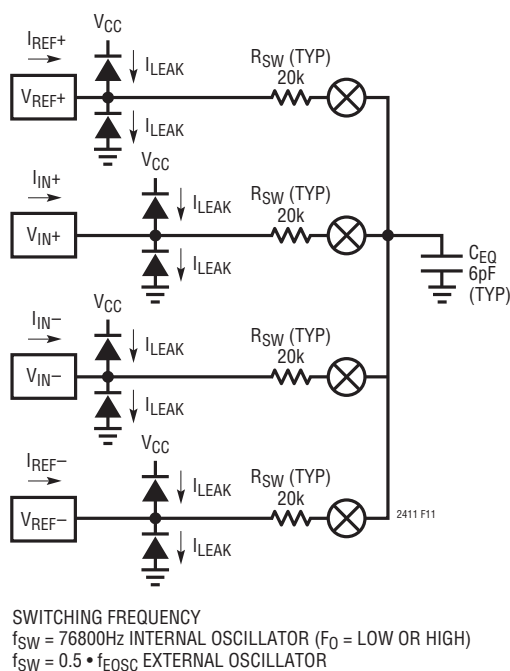

$$I(IN^+)_{AVG} = \frac{V_{IN} + V_{INCM} - V_{REFCM}}{0.5 \cdot R_{EQ}}$$

$$I(IN^-)_{AVG} = \frac{-V_{IN} + V_{INCM} - V_{REFCM}}{0.5 \cdot R_{EQ}}$$

$$I(REF^+)_{AVG} = \frac{1.5 \cdot V_{REF} - V_{INCM} + V_{REFCM}}{0.5 \cdot R_{EQ}} - \frac{V_{IN}^2}{V_{REF} \cdot R_{EQ}}$$

$$I(REF^-)_{AVG} = \frac{-1.5 \cdot V_{REF} - V_{INCM} + V_{REFCM}}{0.5 \cdot R_{EQ}} + \frac{V_{IN}^2}{V_{REF} \cdot R_{EQ}}$$

where:

$$V_{REF} = REF^+ - REF^-$$

$$V_{REFCM} = \left( \frac{REF^+ + REF^-}{2} \right)$$

$$V_{IN} = IN^+ - IN^-$$

$$V_{INCM} = \left( \frac{IN^+ + IN^-}{2} \right)$$

$$R_{EQ} = 10.8\text{M}\Omega \text{ INTERNAL OSCILLATOR } 60\text{Hz Notch } (F_0 = \text{LOW})(\text{LTC2411})$$

$$R_{EQ} = 13.0\text{M}\Omega \text{ INTERNAL OSCILLATOR } 50\text{Hz Notch } (F_0 = \text{HIGH})(\text{LTC2411})$$

$$R_{EQ} = 11.9\text{M}\Omega \text{ INTERNAL OSCILLATOR } (F_0 = \text{LOW})(\text{LTC2411-1})$$

$$R_{EQ} = (1.67 \cdot 10^{12}) / f_{E0SC} \text{ EXTERNAL OSCILLATOR}$$

Figure 11. LTC2411/LTC2411-1 Equivalent Analog Input Circuit

## APPLICATIONS INFORMATION

to a  $13\mu\text{s}$  ( $14.2\mu\text{s}$ ) sampling period. Thus, for settling errors of less than 1ppm, the driving source impedance should be chosen such that  $\tau \leq 13\mu\text{s}/14 = 920\text{ns}$  ( $1.02\mu\text{s}$ ). When an external oscillator of frequency  $f_{\text{EOSC}}$  is used, the sampling period is  $2/f_{\text{EOSC}}$  and, for a settling error of less than 1ppm,  $\tau \leq 0.14/f_{\text{EOSC}}$ .

### Input Current

If complete settling occurs on the input, conversion results will be unaffected by the dynamic input current. An incomplete settling of the input signal sampling process may result in gain and offset errors, but it will not degrade the INL performance of the converter. Figure 11 shows the mathematical expressions for the average bias currents flowing through the  $\text{IN}^+$  and  $\text{IN}^-$  pins as a result of the sampling charge transfers when integrated over a substantial time period (longer than 64 internal clock cycles).

The effect of this input dynamic current can be analyzed using the test circuit of Figure 12. The  $C_{\text{PAR}}$  capacitor includes the LTC2411/LTC2411-1 pin capacitance (5pF typical) plus the capacitance of the test fixture used to obtain the results shown in Figures 13 and 14. A careful implementation can bring the total input capacitance ( $C_{\text{IN}} + C_{\text{PAR}}$ ) closer to 5pF thus achieving better performance than the one predicted by Figures 13 and 14. The effect of the input dynamic current is almost the same for the LTC2411 and the LTC2411-1 and measurements of the LTC2411 with  $F_0 = \text{GND}$  are plotted out as a typical case. For simplicity, two distinct situations can be considered.

For relatively small values of input capacitance ( $C_{\text{IN}} < 0.01\mu\text{F}$ ), the voltage on the sampling capacitor settles almost completely and relatively large values for the source impedance result in only small errors. Such values for  $C_{\text{IN}}$  will deteriorate the converter offset and gain performance without significant benefits of signal filtering and the user is advised to avoid them. Nevertheless, when small values of  $C_{\text{IN}}$  are unavoidably present as parasitics of input multiplexers, wires, connectors or sensors, the LTC2411/LTC2411-1 can maintain their exceptional accuracy while operating with relative large values of source resistance as shown in Figures 13 and 14. These measured results may be slightly different from the first order approximation suggested earlier because they include the effect of

the actual second order input network together with the nonlinear settling process of the input amplifiers. For small  $C_{\text{IN}}$  values, the settling on  $\text{IN}^+$  and  $\text{IN}^-$  occurs almost independently and there is little benefit in trying to match the source impedance for the two pins.

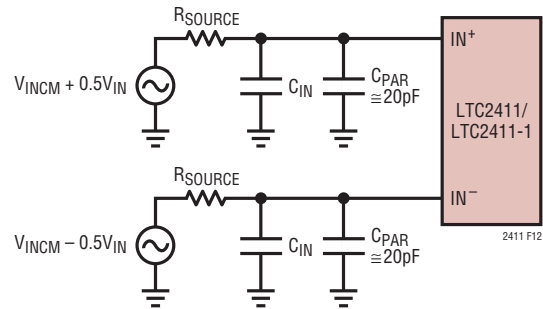

Figure 12. An RC Network at  $\text{IN}^+$  and  $\text{IN}^-$

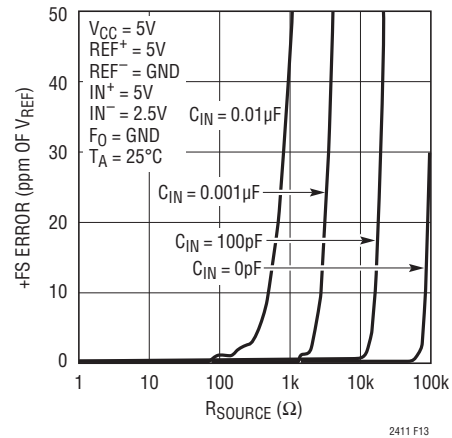

Figure 13. +FS Error vs  $R_{\text{SOURCE}}$  at  $\text{IN}^+$  or  $\text{IN}^-$  (Small  $C_{\text{IN}}$ )

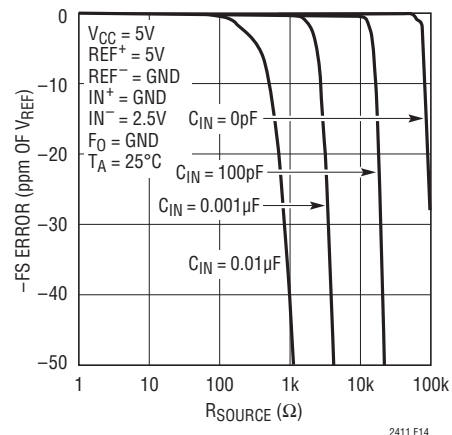

Figure 14. -FS Error vs  $R_{\text{SOURCE}}$  at  $\text{IN}^+$  or  $\text{IN}^-$  (Small  $C_{\text{IN}}$ )

## APPLICATIONS INFORMATION

Larger values of input capacitors ( $C_{IN} > 0.01\mu\text{F}$ ) may be required in certain configurations for anti-aliasing or general input signal filtering. Such capacitors will average the input sampling charge and the external source resistance will see a quasi constant input differential impedance. For the LTC2411, when  $F_0 = \text{LOW}$  (internal oscillator and 60Hz notch), the typical differential input resistance is  $5.4\text{M}\Omega$  which will generate a gain error of approximately  $0.093\text{ppm}$  for each ohm of source resistance driving  $\text{IN}^+$  or  $\text{IN}^-$ . When  $F_0 = \text{HIGH}$  (internal oscillator and 50Hz notch), the typical differential input resistance is  $6.5\text{M}\Omega$  which will generate a gain error of approximately  $0.077\text{ppm}$  for each ohm of source resistance driving  $\text{IN}^+$  or  $\text{IN}^-$ . For the LTC2411-1, the typical differential input resistance is  $6\text{M}\Omega$  which will generate a gain error of approximately  $0.084\text{ppm}$  for each ohm of source resistance driving  $\text{IN}^+$  or  $\text{IN}^-$  ( $F_0 = \text{LOW}$ ). When  $F_0$  is driven by an external oscillator with a frequency  $f_{\text{EOSC}}$  (external conversion clock operation), the typical differential input resistance is  $0.83 \cdot 10^{12}/f_{\text{EOSC}}\Omega$  and each ohm of source resistance driving  $\text{IN}^+$  or  $\text{IN}^-$  will result in  $0.59 \cdot 10^{-6} \cdot f_{\text{EOSC}}\text{ppm}$  gain error. The effect of the source resistance on the two input pins is additive with respect to this gain error. The typical +FS and -FS errors as a function of the sum of the source resistance seen by  $\text{IN}^+$  and  $\text{IN}^-$  for large values of  $C_{IN}$  are shown in Figure 15.

In addition to this gain error, an offset error term may also appear. The offset error is proportional with the mismatch between the source impedance driving the two input pins  $\text{IN}^+$  and  $\text{IN}^-$  and with the difference between the input and reference common mode voltages. While the input drive circuit

nonzero source impedance combined with the converter average input current will not degrade the INL performance, indirect distortion may result from the modulation of the offset error by the common mode component of the input signal. Thus, when using large  $C_{IN}$  capacitor values, it is advisable to carefully match the source impedance seen by the  $\text{IN}^+$  and  $\text{IN}^-$  pins. For the LTC2411, when  $F_0 = \text{LOW}$  (internal oscillator and 60Hz notch), every  $1\Omega$  mismatch in source impedance transforms a full-scale common mode input signal into a differential mode input signal of  $0.093\text{ppm}$ . When  $F_0 = \text{HIGH}$  (internal oscillator and 50Hz notch), every  $1\Omega$  mismatch in source impedance transforms a full-scale common mode input signal into a differential mode input signal of  $0.077\text{ppm}$ . For the LTC2411-1, when internal oscillator is used ( $F_0 = \text{LOW}$ ), every  $1\Omega$  mismatch in source impedance transforms a full-scale common mode input signal into a differential mode input signal of  $0.084\text{ppm}$ . When  $F_0$  is driven by an external oscillator with a frequency  $f_{\text{EOSC}}$ , every  $1\Omega$  mismatch in source impedance transforms a full-scale common mode input signal into a differential mode input signal of  $0.59 \cdot 10^{-6} \cdot f_{\text{EOSC}}\text{ppm}$ . Figure 16 shows the typical offset error due to input common mode voltage for various values of source resistance imbalance between the  $\text{IN}^+$  and  $\text{IN}^-$  pins when large  $C_{IN}$  values are used.

If possible, it is desirable to operate with the input signal common mode voltage very close to the reference signal common mode voltage as is the case in the ratiometric measurement of a symmetric bridge. This configuration eliminates the offset error caused by mismatched source impedances.

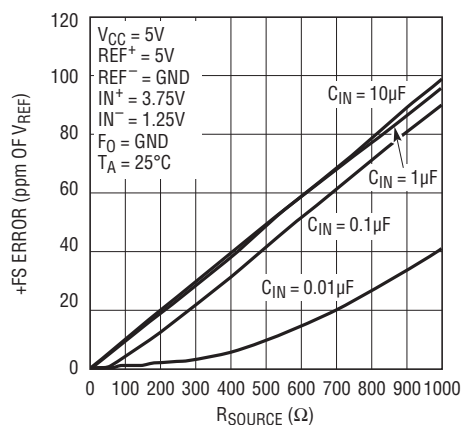

Figure 15a. +FS Error vs  $R_{\text{SOURCE}}$  at  $\text{IN}^+$  or  $\text{IN}^-$  (Large  $C_{IN}$ )

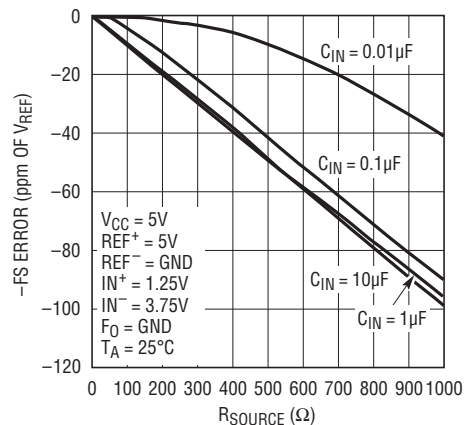
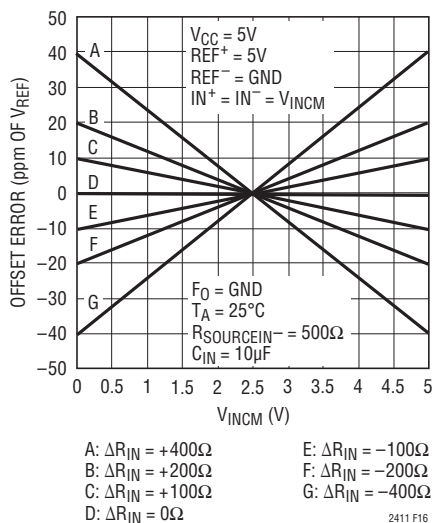

Figure 15b. -FS Error vs  $R_{\text{SOURCE}}$  at  $\text{IN}^+$  or  $\text{IN}^-$  (Large  $C_{IN}$ )

## APPLICATIONS INFORMATION



**Figure 16. Offset Error vs Common Mode Voltage ( $V_{INCM} = IN^+ = IN^-$ ) and Input Source Resistance Imbalance ( $\Delta R_{IN} = R_{SOURCEIN}^+ - R_{SOURCEIN}^-$ ) for Large  $C_{IN}$  Values ( $C_{IN} \geq 1\mu F$ )**

The magnitude of the dynamic input current depends upon the size of the very stable internal sampling capacitors and upon the accuracy of the converter sampling clock. The accuracy of the internal clock over the entire temperature and power supply range is typically better than 1%. Such a specification can also be easily achieved by an external clock. When relatively stable resistors (50ppm/°C) are used for the external source impedance seen by  $IN^+$  and  $IN^-$ , the expected drift of the dynamic current, offset and gain errors will be insignificant (about 1% of their respective values over the entire temperature and voltage range). Even for the most stringent applications, a one-time calibration operation may be sufficient.

In addition to the input sampling charge, the input ESD protection diodes have a temperature dependent leakage current. This current, nominally 1nA ( $\pm 10$ nA max), results in a small offset shift. A 100 $\Omega$  source resistance will create a 0.1 $\mu$ V typical and 1 $\mu$ V maximum offset voltage.

### Reference Current

In a similar fashion, the LTC2411/LTC2411-1 sample the differential reference pins  $REF^+$  and  $REF^-$  transferring small amount of charge to and from the external driving circuits thus producing a dynamic reference current. This current does not change the converter offset, but it may degrade

the gain and INL performance. The effect of this current can be analyzed in the same two distinct situations.

For relatively small values of the external reference capacitors ( $C_{REF} < 0.01\mu F$ ), the voltage on the sampling capacitor settles almost completely and relatively large values for the source impedance result in only small errors. Such values for  $C_{REF}$  will deteriorate the converter offset and gain performance without significant benefits of reference filtering and the user is advised to avoid them.

Larger values of reference capacitors ( $C_{REF} > 0.01\mu F$ ) may be required as reference filters in certain configurations. Such capacitors will average the reference sampling charge and the external source resistance will see a quasi constant reference differential impedance. For the LTC2411, when  $F_0 = LOW$  (internal oscillator and 60Hz notch), the typical differential reference resistance is 3.9M $\Omega$  which will generate a gain error of approximately 0.13ppm for each ohm of source resistance driving  $REF^+$  or  $REF^-$ . When  $F_0 = HIGH$  (internal oscillator and 50Hz notch), the typical differential reference resistance is 4.68M $\Omega$  which will generate a gain error of approximately 0.11ppm for each ohm of source resistance driving  $REF^+$  or  $REF^-$ . For the LTC2411-1, when internal oscillator is used ( $F_0 = LOW$ ), the typical differential reference resistance is 4.29M $\Omega$  which will generate a gain error of approximately 0.12ppm for each ohm of source resistance driving  $REF^+$  or  $REF^-$ . When  $F_0$  is driven by an external oscillator with a frequency  $f_{EOSC}$  (external conversion clock operation), the typical differential reference resistance is  $0.60 \cdot 10^{12}/f_{EOSC}\Omega$  and each ohm of source resistance driving  $REF^+$  or  $REF^-$  will result in  $0.823 \cdot 10^{-6} \cdot f_{EOSC}$ ppm gain error. The effect of the source resistance on the two reference pins is additive with respect to this gain error. The typical FS errors for various combinations of source resistance seen by the  $REF^+$  and  $REF^-$  pins and external capacitance  $C_{REF}$  connected to these pins are shown in Figures 17 and 18. Typical -FS errors are similar to +FS errors with opposite polarity.

In addition to this gain error, the converter INL performance is degraded by the reference source impedance. For LTC2411, when  $F_0 = LOW$  (internal oscillator and 60Hz notch), every 100 $\Omega$  of source resistance driving  $REF^+$  or  $REF^-$  translates into about 0.45ppm additional INL error. When  $F_0 = HIGH$  (internal oscillator and 50Hz

## APPLICATIONS INFORMATION

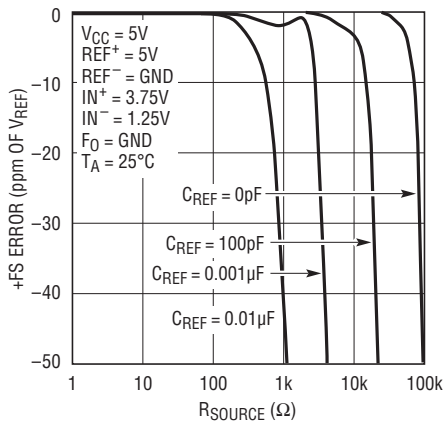

2411 F17a

Figure 17a. +FS Error vs  $R_{SOURCE}$  at REF+ or REF- (Small  $C_{IN}$ )

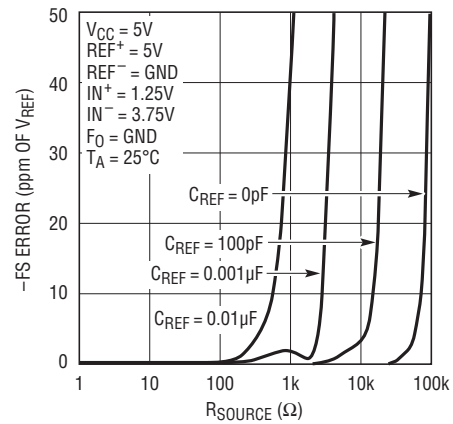

2411 F17b

Figure 17b. -FS Error vs  $R_{SOURCE}$  at REF+ or REF- (Small  $C_{IN}$ )

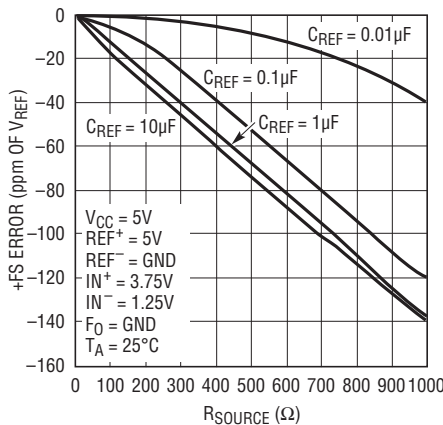

2411 F18a

Figure 18a. +FS Error vs  $R_{SOURCE}$  at REF+ or REF- (Large  $C_{IN}$ )

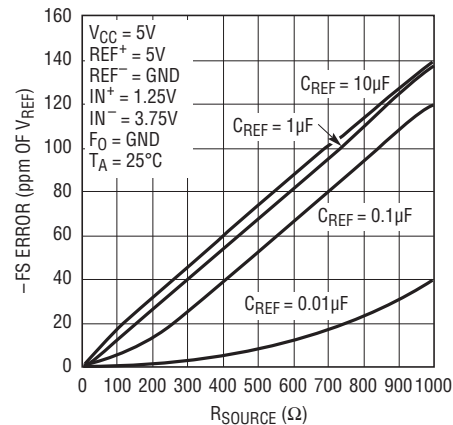

2411 F18b

Figure 18b. -FS Error vs  $R_{SOURCE}$  at REF+ or REF- (Large  $C_{IN}$ )

notch), every 100Ω of source resistance driving REF+ or REF- translates into about 0.37ppm additional INL error. For the LTC2411-1, when  $F_O = LOW$ , every 100Ω of source resistance driving REF+ or REF- translates into about 0.41ppm additional INL error. When  $F_O$  is driven by an external oscillator with a frequency  $f_{EOSC}$ , every 100Ω of source resistance driving REF+ or REF- translates into about  $2.91 \cdot 10^{-6} \cdot f_{EOSC}$ ppm additional INL error. Figure 19 shows the typical INL error due to the source resistance driving the REF+ or REF- pins when large  $C_{REF}$  values are used. The effect of the source resistance on the two reference pins is additive with respect to this INL error. In general, matching of source impedance for the REF+ and REF- pins does not help the gain or the INL error. The user is thus advised to minimize the combined source impedance driving the REF+ and REF- pins rather than to try to match it.

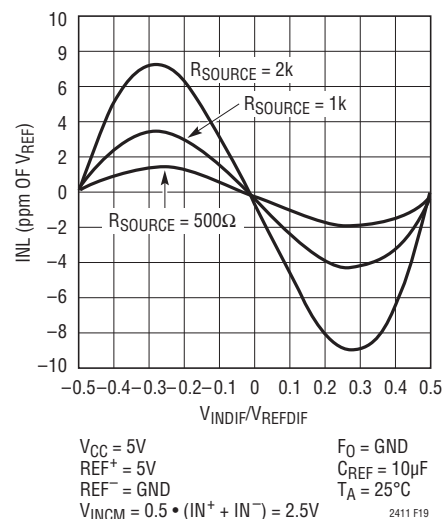

2411 F19

Figure 19. INL vs Differential Input Voltage ( $V_{IN} = IN^+ = IN^-$ ) and Reference Source Resistance ( $R_{SOURCE}$  at REF+ and REF-) for Large  $C_{REF}$  Values ( $C_{REF} \geq 1\mu F$ )

## APPLICATIONS INFORMATION

The magnitude of the dynamic reference current depends upon the size of the very stable internal sampling capacitors and upon the accuracy of the converter sampling clock. The accuracy of the internal clock over the entire temperature and power supply range is typical better than 1%. Such a specification can also be easily achieved by an external clock. When relatively stable resistors (50ppm/°C) are used for the external source impedance seen by REF<sup>+</sup> and REF<sup>-</sup>, the expected drift of the dynamic current gain error will be insignificant (about 1% of its value over the entire temperature and voltage range). Even for the most stringent applications, a one-time calibration operation may be sufficient.

In addition to the reference sampling charge, the reference pins ESD protection diodes have a temperature dependent leakage current. This leakage current, nominally 1nA ( $\pm 10$ nA max), results in a small gain error. A 100 $\Omega$  source resistance will create a 0.05 $\mu$ V typical and 0.5 $\mu$ V maximum full-scale error.

### Output Data Rate

When using its internal oscillator, the LTC2411 can produce up to 7.5 readings per second with a notch frequency of 60Hz ( $F_0 = \text{LOW}$ ) and 6.25 readings per second with a notch frequency of 50Hz ( $F_0 = \text{HIGH}$ ) and the LTC2411-1 can produce up to 6.8 readings per second with  $F_0 = \text{LOW}$ . The actual output data rate will depend upon the length of the sleep and data output phases which are controlled by the user and which can be made insignificantly short. When operated with an external conversion clock ( $F_0$  connected to an external oscillator), the LTC2411/LTC2411-1 output data rate can be increased as desired. The duration of the conversion phase is  $20510/f_{\text{EOSC}}$ . If  $f_{\text{EOSC}} = 153600\text{Hz}$ , the converter behaves as if the internal oscillator is used and the notch is set at 60Hz. There is no significant difference in the LTC2411/LTC2411-1 performance between these two operation modes.

An increase in  $f_{\text{EOSC}}$  over the nominal 153600Hz will translate into a proportional increase in the maximum output data rate. This substantial advantage is nevertheless accompanied by three potential effects, which must be carefully considered.

First, a change in  $f_{\text{EOSC}}$  will result in a proportional change in the internal notch position and in a reduction of the converter differential mode rejection at the power line frequency. In many applications, the subsequent performance degradation can be substantially reduced by relying upon the LTC2411/LTC2411-1's exceptional common mode rejection and by carefully eliminating common mode to differential mode conversion sources in the input circuit. The user should avoid single-ended input filters and should maintain a very high degree of matching and symmetry in the circuits driving the IN<sup>+</sup> and IN<sup>-</sup> pins.

Second, the increase in clock frequency will increase proportionally the amount of sampling charge transferred through the input and the reference pins. If large external input and/or reference capacitors ( $C_{\text{IN}}$ ,  $C_{\text{REF}}$ ) are used, the previous section provides formulae for evaluating the effect of the source resistance upon the converter performance for any value of  $f_{\text{EOSC}}$ . If small external input and/or reference capacitors ( $C_{\text{IN}}$ ,  $C_{\text{REF}}$ ) are used, the effect of the external source resistance upon the LTC2411/LTC2411-1 typical performance can be inferred from Figures 13, 14 and 17 in which the horizontal axis is scaled by  $153600/f_{\text{EOSC}}$ .

Third, an increase in the frequency of the external oscillator above 460800Hz (a more than 3 $\times$  increase in the output data rate) will start to decrease the effectiveness of the internal auto-calibration circuits. This will result in a progressive degradation in the converter accuracy and linearity. Typical measured performance curves for output data rates up to 25 readings per second are shown in Figures 20 to 27. In order to obtain the highest possible level of accuracy from this converter at output data rates above 7.5 readings per second, the user is advised to maximize the power supply voltage used and to limit the maximum ambient operating temperature. In certain circumstances, a reduction of the differential reference voltage may be beneficial.

### Input Bandwidth

The combined effect of the internal sinc<sup>4</sup> digital filter and of the analog and digital auto-calibration circuits determines the LTC2411/LTC2411-1 input bandwidth. When the internal oscillator is used, the 3dB input bandwidth

## APPLICATIONS INFORMATION

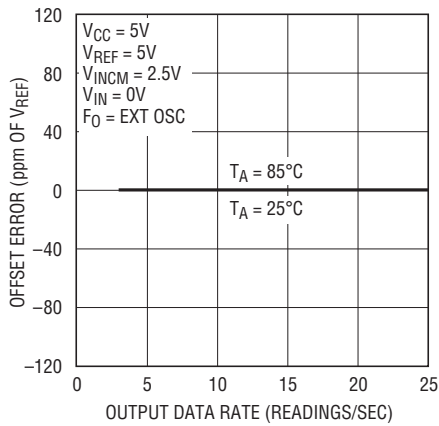

2411 F20

Figure 20. Offset Error vs Output Data Rate and Temperature

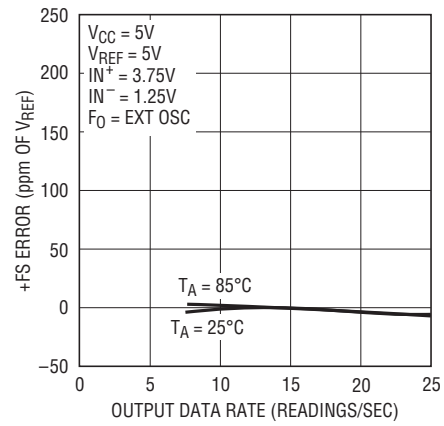

2411 F21

Figure 21. +FS Error vs Output Data Rate and Temperature

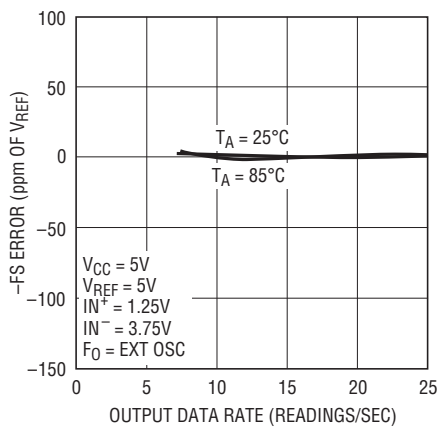

2411 F22

Figure 22. -FS Error vs Output Data Rate and Temperature

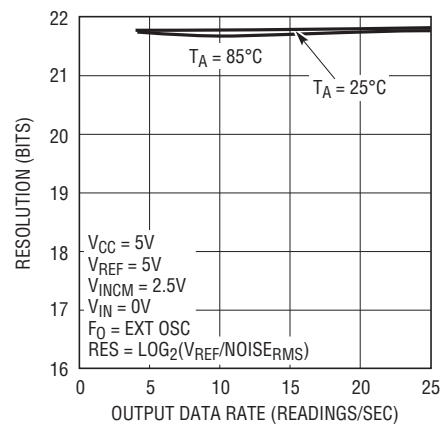

2411 F23

Figure 23. Resolution ( $\text{Noise}_{\text{RMS}} \leq 1\text{LSB}$ ) vs Output Data Rate and Temperature

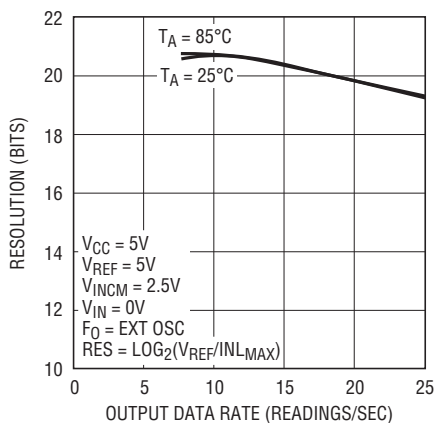

2411 F24

Figure 24. Resolution ( $\text{INL}_{\text{RMS}} \leq 1\text{LSB}$ ) vs Output Data Rate and Temperature

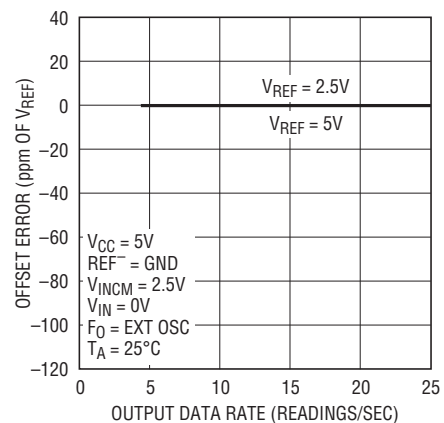

2411 F25

Figure 25. Offset Error vs Output Data Rate and Reference Voltage

## APPLICATIONS INFORMATION

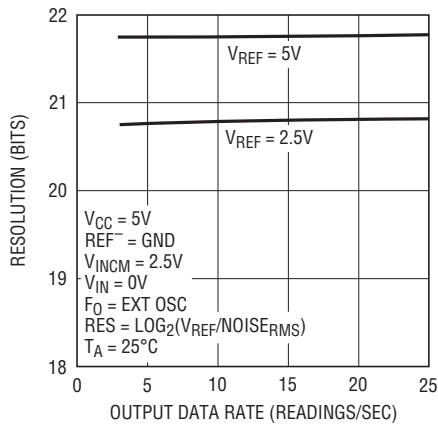

**Figure 26. Resolution ( $\text{Noise}_{\text{RMS}} \leq 1\text{LSB}$ ) vs Output Data Rate and Reference Voltage**

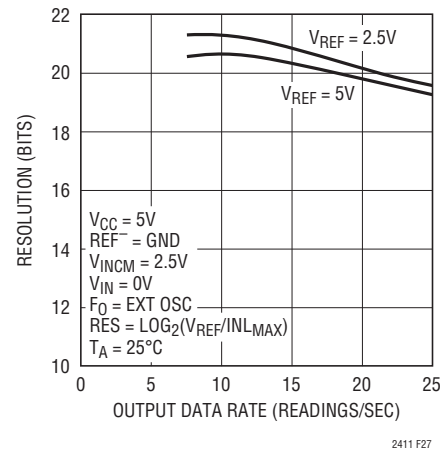
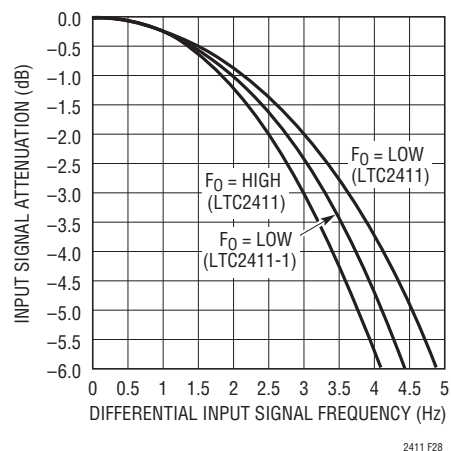

**Figure 27. Resolution ( $\text{INL}_{\text{MAX}} \leq 1\text{LSB}$ ) vs Output Data Rate and Reference Voltage**

of the LTC2411 is 3.63Hz for 60Hz notch frequency ( $F_0 = \text{LOW}$ ) and 3.02Hz for 50Hz notch frequency ( $F_0 = \text{HIGH}$ ). The 3dB input bandwidth for the LTC2411-1 is 3.30Hz ( $F_0 = \text{LOW}$ ). If an external conversion clock generator of frequency  $f_{\text{EOSC}}$  is connected to the  $F_0$  pin, the 3dB input bandwidth is  $0.236 \cdot 10^{-6} \cdot f_{\text{EOSC}}$ .

Due to the complex filtering and calibration algorithms utilized, the converter input bandwidth is not modeled very accurately by a first order filter with the pole located at the 3dB frequency. When the internal oscillator is used, the shape of the LTC2411/LTC2411-1 input bandwidth is shown in Figure 28. When an external oscillator of frequency  $f_{\text{EOSC}}$  is used, the shape of the LTC2411/LTC2411-1 input bandwidth can be derived from Figure 28,  $F_0 = \text{LOW}$  curve of the LTC2411 in which the horizontal axis is scaled by  $f_{\text{EOSC}}/153600$ .

The conversion noise ( $1.45\mu\text{V}_{\text{RMS}}$  typical for  $V_{\text{REF}} = 5\text{V}$ ) can be modeled as a white noise source connected to a noise free converter. The noise spectral density is  $70\text{nV}/\sqrt{\text{Hz}}$  for an infinite bandwidth source and  $126\text{nV}/\sqrt{\text{Hz}}$  for a single 0.5MHz pole source. From these numbers, it is clear that particular attention must be given to the design of external amplification circuits. Such circuits face the simultaneous requirements of very low bandwidth (just a few Hz) in order to reduce the output referred noise and relatively high bandwidth (at least 500kHz) necessary to drive the input switched-capacitor network. A possible



**Figure 28. Input Signal Bandwidth Using the Internal Oscillator**

solution is a high gain, low bandwidth amplifier stage followed by a high bandwidth unity-gain buffer.

When external amplifiers are driving the LTC2411/LTC2411-1, the ADC input referred system noise calculation can be simplified by Figure 29. The noise of an amplifier driving the LTC2411/LTC2411-1 input pin can be modeled as a band-limited white noise source. Its bandwidth can be approximated by the bandwidth of a single pole lowpass filter with a corner frequency  $f_i$ . The amplifier noise spectral density is  $n_i$ . From Figure 29, using  $f_i$  as the x-axis selector, we can find on the y-axis the noise equivalent bandwidth  $f_{\text{req}_i}$  of the input driving amplifier. This bandwidth includes

## APPLICATIONS INFORMATION

the band limiting effects of the ADC internal calibration and filtering. The noise of the driving amplifier referred to the converter input and including all these effects can be calculated as  $N = n_i \cdot \sqrt{f_{req_i}}$ . The total system noise (referred to the LTC2411/LTC2411-1 input) can now be obtained by summing as square root of sum of squares the three ADC input referred noise sources: the LTC2411/LTC2411-1 internal noise (1.45 $\mu$ V), the noise of the IN<sup>+</sup> driving amplifier and the noise of the IN<sup>-</sup> driving amplifier.

If the F<sub>0</sub> pin is driven by an external oscillator of frequency f<sub>EOSC</sub>, Figure 29 can still be used for noise calculation if the x-axis is scaled by f<sub>EOSC</sub>/153600. For large values of the ratio f<sub>EOSC</sub>/153600, the Figure 29 plot accuracy begins to decrease, but in the same time the LTC2411/LTC2411-1

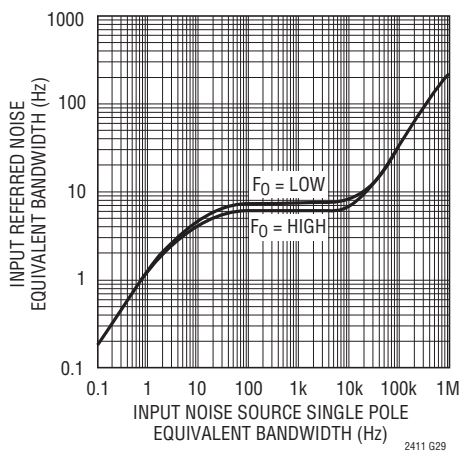

**Figure 29. Input Referred Noise Equivalent Bandwidth of an Input Connected White Noise Source**

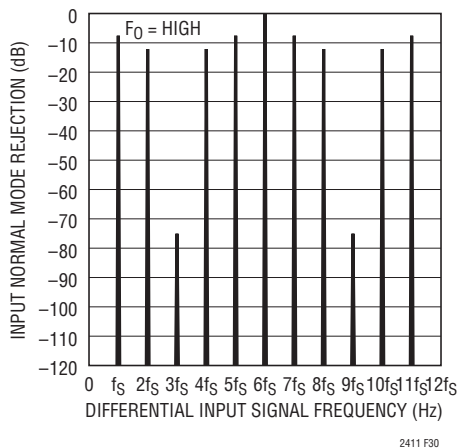

**Figure 30. Input Normal Mode Rejection, Internal Oscillator and 50Hz Notch (LTC2411)**

noise floor rises and the noise contribution of the driving amplifiers lose significance.

### Normal Mode Rejection and Anti-Aliasing

One of the advantages delta-sigma ADCs offer over conventional ADCs is on-chip digital filtering. Combined with a large oversampling ratio, the LTC2411/LTC2411-1 significantly simplifies anti-aliasing filter requirements.

The sinc<sup>4</sup> digital filter provides greater than 120dB normal mode rejection at all frequencies except DC and integer multiples of the modulator sampling frequency (f<sub>S</sub>). The LTC2411/LTC2411-1's auto-calibration circuits further simplify the anti-aliasing requirements by additional normal mode signal filtering both in the analog and digital domain. Independent of the operating mode, f<sub>S</sub> = 256 • f<sub>N</sub> = 2048 • f<sub>OUTMAX</sub> where f<sub>N</sub> is the notch frequency and f<sub>OUTMAX</sub> is the maximum output data rate. In the internal oscillator mode, for the LTC2411, f<sub>S</sub> = 12800Hz with a 50Hz notch setting and f<sub>S</sub> = 15360Hz with a 60Hz notch setting. For the LTC2411-1, f<sub>S</sub> = 13980Hz (F<sub>0</sub> = LOW). In the external oscillator mode, f<sub>S</sub> = f<sub>EOSC</sub>/10.

The combined normal mode rejection performance is shown in Figure 30 for the internal oscillator with 50Hz notch setting (F<sub>0</sub> = HIGH) and in Figure 31 for the internal oscillator with F<sub>0</sub> = LOW and for the external oscillator mode. The regions of low rejection occurring at integer multiples of f<sub>S</sub> have a very narrow bandwidth. Magnified details of the normal mode rejection curves are shown

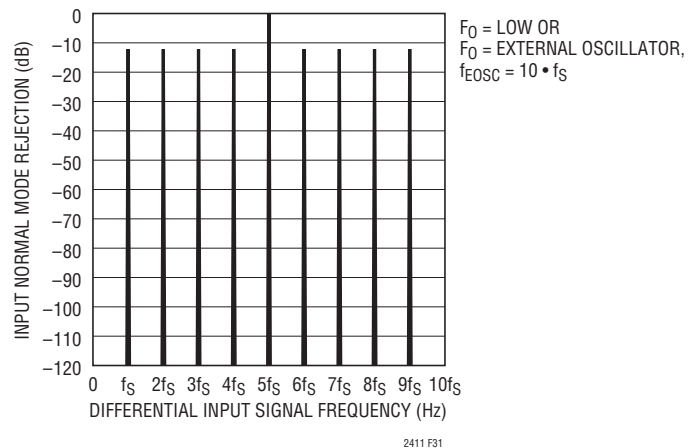

**Figure 31. Input Normal Mode Rejection, Internal Oscillator and F<sub>0</sub> = LOW or External Oscillator**

## APPLICATIONS INFORMATION

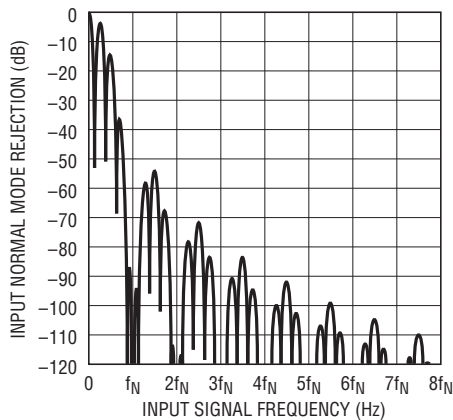

2411 F32

**Figure 32. Input Normal Mode Rejection**

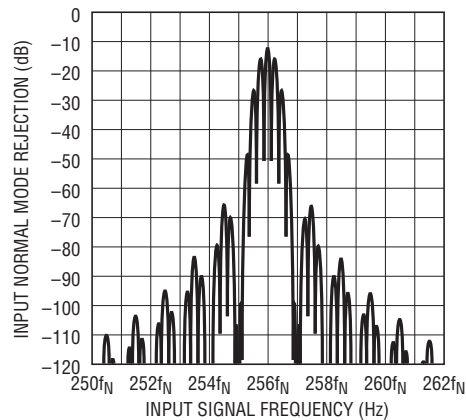

2411 F33

**Figure 33. Input Normal Mode Rejection**

in Figure 32 (rejection near DC) and Figure 33 (rejection at  $f_S = 256f_N$ ) where  $f_N$  represents the notch frequency. These curves have been derived for the external oscillator mode but they can be used in all operating modes by appropriately selecting the  $f_N$  value.

The user can expect to achieve in practice this level of performance using the internal oscillator as it is demonstrated by Figures 34 to 36. Typical measured values of the normal mode rejection of the LTC2411 operating with an internal oscillator and a 60Hz notch setting are shown in Figure 34 superimposed over the theoretical calculated curve. Similarly, typical measured values of the normal mode rejection of the LTC2411 operating with an internal oscillator and a 50Hz notch setting are shown in Figure 35 superimposed over the theoretical calculated curve.

As a result of these remarkable normal mode specifications, minimal (if any) anti-alias filtering is required in front of the LTC2411/LTC2411-1. If passive RC components are placed in front of the LTC2411/LTC2411-1, the input dynamic current should be considered (see Input Current section). In cases where large effective RC time constants are used, an external buffer amplifier may be required to minimize the effects of dynamic input current.

Traditional high order delta-sigma modulators, while providing very good linearity and resolution, suffer from potential instabilities at large input signal levels. The proprietary architecture used for the LTC2411/LTC2411-1 third order modulator resolves this problem and guarantees a predictable stable behavior at input signal levels of

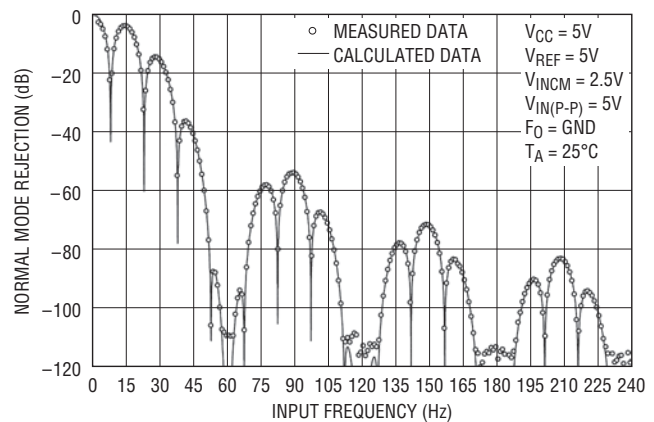

2411 F34

**Figure 34. Input Normal Mode Rejection vs Input Frequency (LTC2411)**

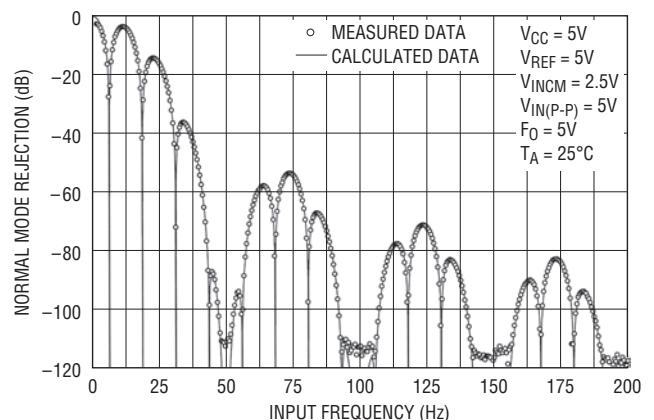

2411 F35

**Figure 35. Input Normal Mode Rejection vs Input Frequency (LTC2411)**

## APPLICATIONS INFORMATION

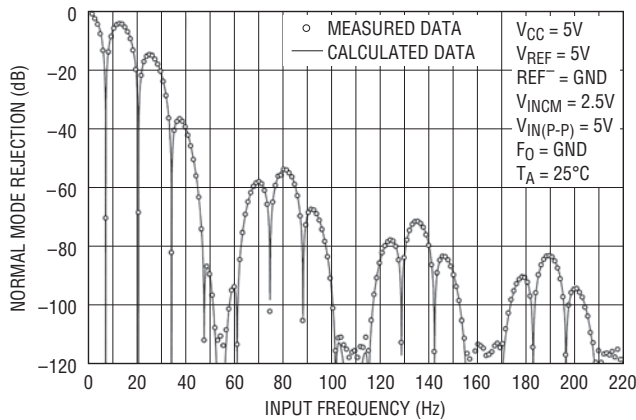
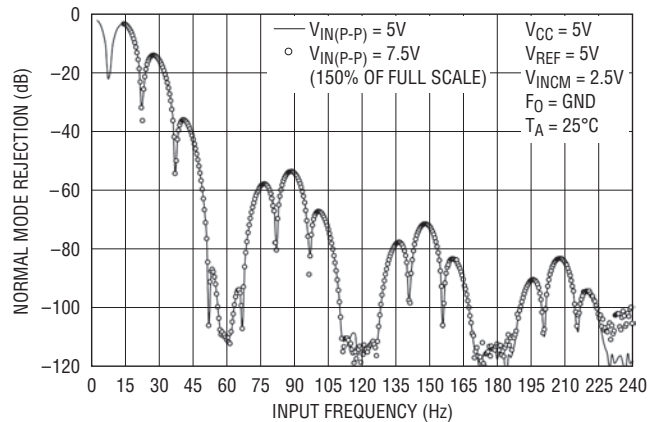

**Figure 36. Input Normal Mode Rejection vs Input Frequency (LTC2411-1)**

up to 150% of full scale. In many industrial applications, it is not uncommon to have to measure microvolt level signals superimposed over volt level perturbations and LTC2411/LTC2411-1 are eminently suited for such tasks. When the perturbation is differential, the specification of interest is the normal mode rejection for large input signal levels. With a reference voltage  $V_{REF} = 5V$ , the LTC2411/LTC2411-1 have a full-scale differential input range of 5V peak-to-peak. Figures 37 and 38 show measurement results for the LTC2411 normal mode rejection ratio with a 7.5V peak-to-peak (150% of full scale) input signal superimposed over the more traditional normal mode rejection ratio results obtained with a 5V peak-to-peak (full scale) input signal and Figure 39 shows the corresponding measurement result for the LTC2411-1. It is clear that the LTC2411/LTC2411-1 rejection performance is maintained with no compromises in this extreme situation. When operating with large input signal levels, the user must observe that such signals do not violate the device absolute maximum ratings.

### BRIDGE APPLICATIONS

Typical strain gauge based bridges deliver only 2mV/Volt of excitation. As the maximum reference voltage of the LTC2411/LTC2411-1 is 5V, remote sensing of applied excitation without additional circuitry requires that excitation be limited to 5V. This gives only 10mV full scale, which can be resolved to 1 part in 5000 without averaging. For many solid state sensors, this is comparable to the



**Figure 37. Measured Input Normal Mode Rejection vs Input Frequency (LTC2411)**

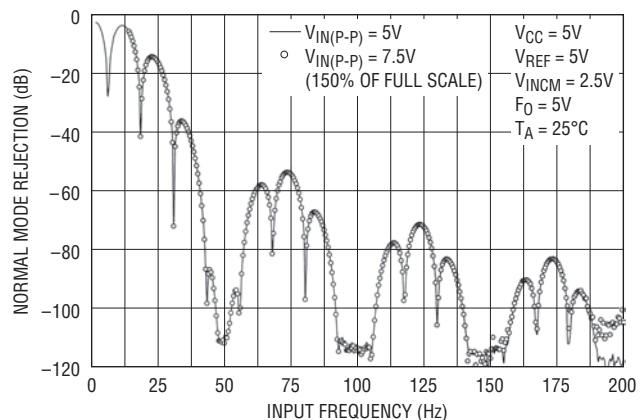

**Figure 38. Measured Input Normal Mode Rejection vs Input Frequency (LTC2411)**

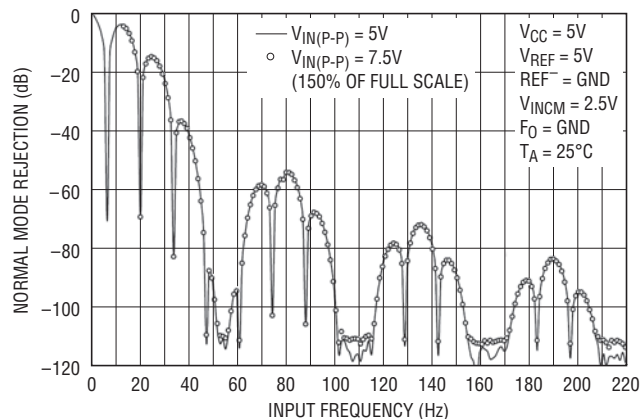

**Figure 39. Measured Input Normal Mode Rejection vs Input Frequency (LTC2411-1)**

## APPLICATIONS INFORMATION

sensor. Averaging 64 samples however reduces the noise level by a factor of eight, bringing the resolving power to 1 part in 40000, comparable to better weighing systems. Hysteresis and creep effects in the load cells are typically much greater than this. Most applications that require strain measurements to this level of accuracy are measuring slowly changing phenomena, hence the time required to average a large number of readings is usually not an issue. For those systems that require accurate measurement of a small incremental change on a significant tare weight, the lack of history effects in the LTC2400 family is of great benefit.

For those applications that cannot be fulfilled by the LTC2411/LTC2411-1 alone, compensating for error in external amplification can be done effectively due to the “no latency” feature of the LTC2411/LTC2411-1. No latency operation allows samples of the amplifier offset and gain to be interleaved with weighing measurements. The use of correlated double sampling allows suppression of 1/f noise, offset and thermocouple effects within the bridge. Correlated double sampling involves alternating the polarity of excitation and dealing with the reversal of input polarity mathematically. Alternatively, bridge excitation can be increased to as much as  $\pm 10V$ , if one of several precision attenuation techniques is used to produce a precision divide operation on the reference signal. Another option is the use of a reference within the 5V input range of the

LTC2411/LTC2411-1 and developing excitation via fixed gain, or LTC1043 based voltage multiplication, along with remote feedback in the excitation amplifiers, as shown in Figures 45 and 46.

Figure 40 shows an example of a simple bridge connection. Note that it is suitable for any bridge application where measurement speed is not of the utmost importance. For many applications where large vessels are weighed, the average weight over an extended period of time is of concern and short term weight is not readily determined due to movement of contents, or mechanical resonance. Often, large weighing applications involve load cells located at each load bearing point, the output of which can be summed passively prior to the signal processing circuitry, actively with amplification prior to the ADC, or can be digitized via multiple ADC channels and summed mathematically. The mathematical summation of the output of multiple LTC2411/LTC2411-1's provide the benefit of a root square reduction in noise. The low power consumption of the LTC2411/LTC2411-1 make it attractive for multidrop communication schemes where the ADC is located within the load-cell housing.

A direct connection to a load cell is perhaps best incorporated into the load-cell body, as minimizing the distance to the sensor largely eliminates the need for protection devices, RFI suppression and wiring. The LTC2411/

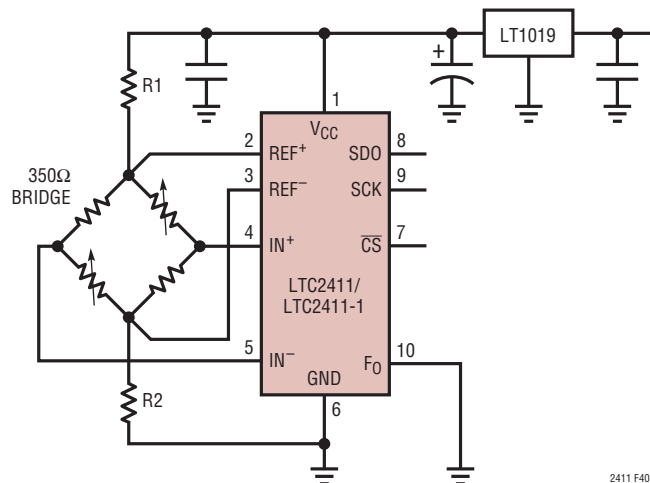

R1 AND R2 CAN BE USED TO INCREASE TOLERABLE AC COMPONENT ON REF SIGNALS

Figure 40. Simple Bridge Connection

## APPLICATIONS INFORMATION

LTC2411-1 exhibit extremely low temperature dependent drift. As a result, exposure to external ambient temperature ranges does not compromise performance. The incorporation of any amplification considerably complicates thermal stability, as input offset voltages and currents, temperature coefficient of gain settling resistors all become factors.

The circuit in Figure 41 shows an example of a simple amplification scheme. This example produces a differential output with a common mode voltage of 2.5V, as determined by the bridge. The use of a true three amplifier instrumentation amplifier is not necessary, as the LTC2411/LTC2411-1 have common mode rejection far beyond that of most amplifiers. The LTC1051 is a dual autozero amplifier that can be used to produce a gain of 30 before its input referred noise dominates the LTC2411/LTC2411-1 noise. This example shows a gain of 34, that is determined by a feedback network built using a resistor array containing eight individual resistors. The resistors are organized to optimize temperature tracking in the presence of thermal gradients. The second LTC1051 buffers

the low noise input stage from the transient load steps produced during conversion.

The gain stability and accuracy of this approach is very good, due to a statistical improvement in resistor matching due to individual error contribution being reduced. A gain of 34 may seem low, when compared to common practice in earlier generations of load-cell interfaces, however the accuracy of the LTC2411/LTC2411-1 changes the rationale. Achieving high gain accuracy and linearity at higher gains may prove difficult, while providing little benefit in terms of noise reduction.

At a gain of 100, the gain error that could result from typical open-loop gain of 160dB is  $-1\text{ppm}$ , however, worst-case is at the minimum gain of 116dB, giving a gain error of  $-158\text{ppm}$ . Worst-case gain error at a gain of 34, is  $-54\text{ppm}$ . The use of the LTC1051A reduces the worst-case gain error to  $-33\text{ppm}$ . The advantage of gain higher than 34, then becomes dubious, as the input referred noise sees little improvement<sup>1</sup> and gain accuracy is potentially compromised.

<sup>1</sup>Input referred noise for  $A_V = 34$  is approximately  $0.05\mu\text{V}_{\text{RMS}}$ , whereas at a gain of 50, it would be  $0.048\mu\text{V}_{\text{RMS}}$ .

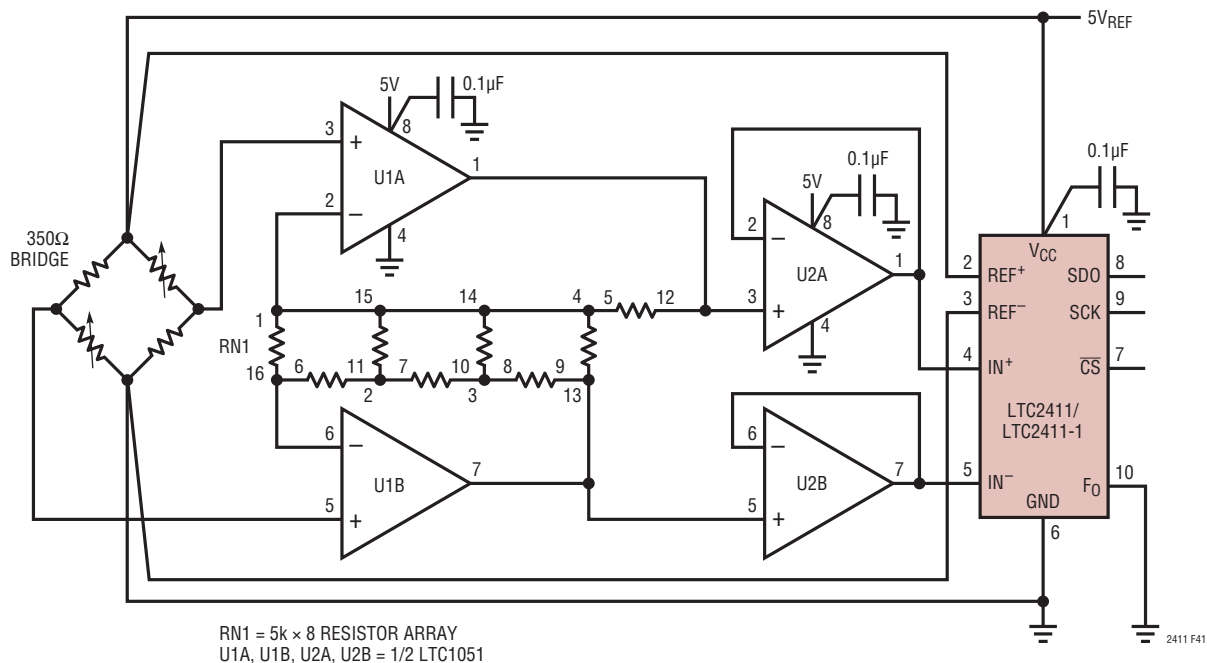

Figure 41. Using Autozero Amplifiers to Reduce Input Referred Noise

## APPLICATIONS INFORMATION

Note that this 4-amplifier topology has advantages over the typical integrated 3-amplifier instrumentation amplifier in that it does not have the high noise level common in the output stage that usually dominates when an instrumentation amplifier is used at low gain. If this amplifier is used at a gain of 10, the gain error is only 10ppm and input referred noise is reduced to  $0.15\mu\text{V}_{\text{RMS}}$ . The buffer stages can also be configured to provide gain of up to 50 with high gain stability and linearity.

Figure 42 shows an example of a single amplifier used to produce single-ended gain. This topology is best used in applications where the gain setting resistor can be made to match the temperature coefficient of the strain gauges. If the bridge is composed of precision resistors, with only one or two variable elements, the reference arm of the bridge can be made to act in conjunction with the feedback resistor to determine the gain. If the feedback resistor is incorporated into the design of the load cell, using resistors which match the temperature coefficient of the load-cell elements, good results can be achieved without the need for resistors with a high degree of absolute accuracy. The common mode voltage in this case, is again a function of the bridge output. Differential gain as used with a  $350\Omega$  bridge is:

$$A_V = 9.95 = \frac{R1 + R2}{R1 + 175\Omega}$$

Common mode gain is half the differential gain. The maximum differential signal that can be used is  $1/4 V_{\text{REF}}$ , as opposed to  $1/2 V_{\text{REF}}$  in the 2-amplifier topology above.

### Remote Half Bridge Interface

As opposed to full bridge applications, typical half bridge applications must contend with nonlinearity in the bridge output, as signal swing is often much greater. Applications include RTD's, thermistors and other resistive elements that undergo significant changes over their span. For single variable element bridges, the nonlinearity of the half bridge

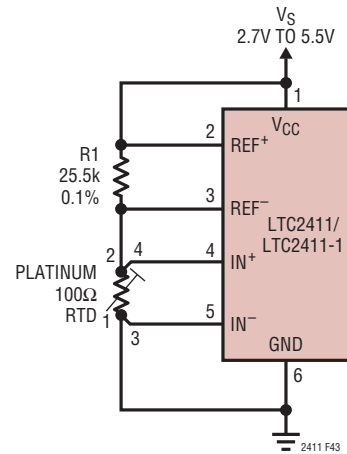
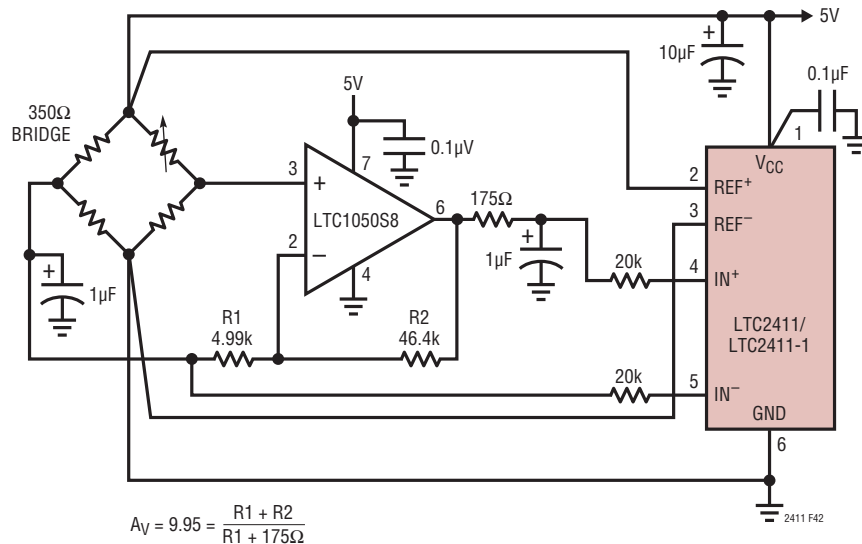

Figure 43. Remote Half Bridge Interface



$$A_V = 9.95 = \frac{R1 + R2}{R1 + 175\Omega}$$

Figure 42. Bridge Amplification Using a Single Amplifier

## APPLICATIONS INFORMATION

output can be eliminated completely; if the reference arm of the bridge is used as the reference to the ADC, as shown in Figure 43. The LTC2411/LTC2411-1 can accept inputs up to  $1/2 V_{REF}$ . Hence, the reference resistor R1 must be at least  $2\times$  the highest value of the variable resistor.

In the case of  $100\Omega$  platinum RTD's, this would suggest a value of  $800\Omega$  for R1. Such a low value for R1 is not advisable due to self-heating effects. A value of  $25.5k$  is shown for R1, reducing self-heating effects to acceptable levels for most sensors.

The basic circuit shown in Figure 43 shows connections for a full 4-wire connection to the sensor, which may be located remotely. The differential input connections will reject induced or coupled 60Hz interference, however, the reference inputs do not have the same rejection. If 60Hz or other noise is present on the RTD, a low pass filter is recommended as shown in Figure 44. Note that you cannot place a large capacitor directly at the junction of R1 and R2, as it will store charge from the sampling process. A better approach is to produce a low pass filter decoupled from the input lines with a high value resistor (R3).

The use of a third resistor in the half bridge, between the variable and fixed elements gives essentially the same

result as the two resistor version, but has a few benefits. If, for example, a  $25k$  reference resistor is used to set the excitation current with a  $100\Omega$  RTD, the negative reference input is sampling the same external node as the positive input, but may result in errors if used with a long cable. For short cable applications, the errors may be acceptably low. If instead the single  $25k$  resistor is replaced with a  $10k$  5% and a  $10k$  0.1% reference resistor, the noise level introduced at the reference, at least at higher frequencies, will be reduced. A filter can be introduced into the network, in the form of one or more capacitors, or ferrite beads, as long as the sampling pulses are not translated into an error. The reference voltage is also reduced, but this is not undesirable, as it will decrease the value of the LSB, although, not the input referred noise level.

The circuit shown in Figure 44 shows a more rigorous example of Figure 43, with increased noise suppression and more protection for remote applications.

Figure 45 shows an example of gain in the excitation circuit and remote feedback from the bridge. The LTC1043s provide voltage multiplication, providing  $\pm 10V$  from a  $5V$  reference with only 1ppm error. The amplifiers are used at unity-gain and, hence, introduce a very little error due to

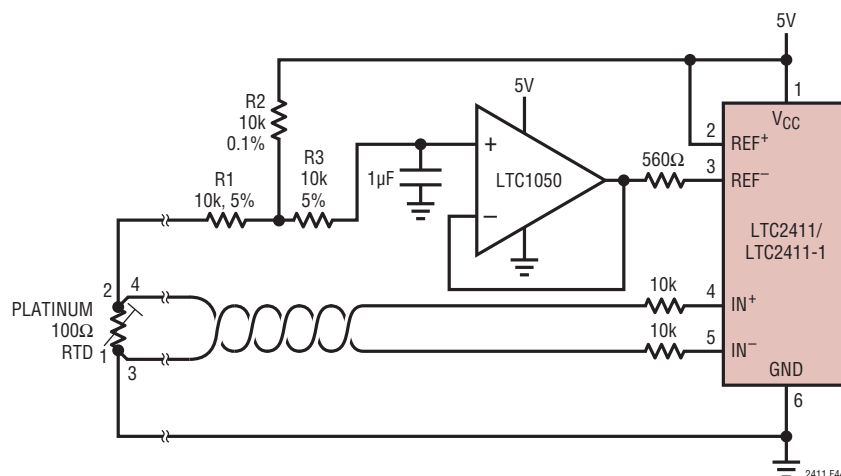

Figure 44. Remote Half Bridge Sensing with Noise Suppression on Reference

## APPLICATIONS INFORMATION

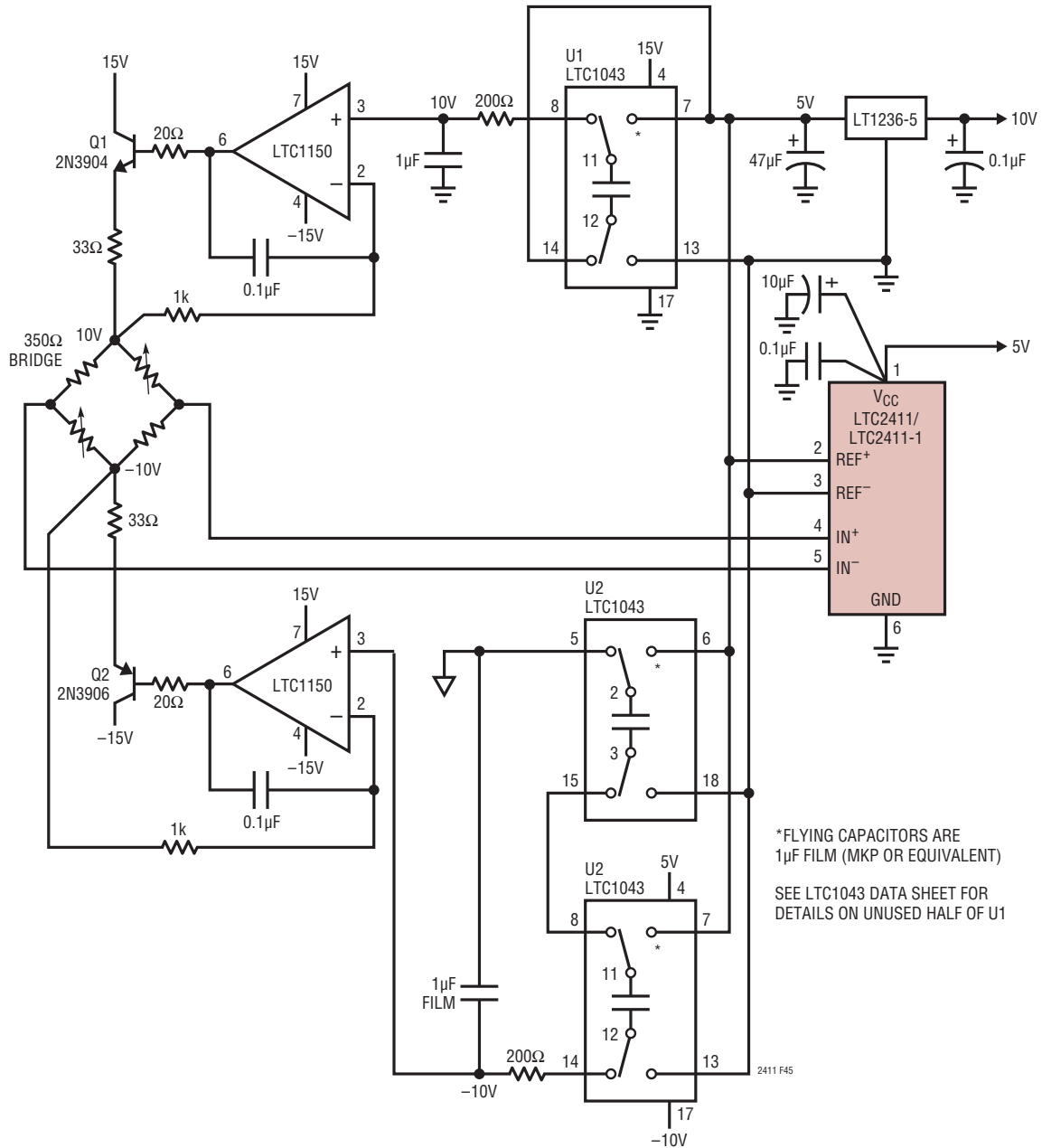

Figure 45. LTC1043 Provides Precise 4× Reference for Excitation Voltages

## APPLICATIONS INFORMATION

gain error or due to offset voltages. A  $1\mu\text{V}/^\circ\text{C}$  offset voltage drift translates into  $0.05\text{ppm}/^\circ\text{C}$  gain error. Simpler alternatives, with the amplifiers providing gain using resistor arrays for feedback, can produce results that are similar to bridge sensing schemes via attenuators. Note that the amplifiers must have high open-loop gain or gain error will be a source of error. The fact that input offset voltage has relatively little effect on overall error may lead one to use low performance amplifiers for this application. Note that the gain of a device such as an LF156, ( $25\text{V}/\text{mV}$  over temperature) will produce a worst-case error of  $-180\text{ppm}$  at a noise gain of 3, such as would be encountered in an inverting gain of 2, to produce  $-10\text{V}$  from a  $5\text{V}$  reference.

The error associated with the  $10\text{V}$  excitation would be  $-80\text{ppm}$ . Hence, overall reference error could be as high as  $130\text{ppm}$ , the average of the two.

Figure 47 shows a similar scheme to provide excitation using resistor arrays to produce precise gain. The circuit is configured to provide  $10\text{V}$  and  $-5\text{V}$  excitation to the bridge, producing a common mode voltage at the input

to the LTC2411/LTC2411-1 of  $2.5\text{V}$ , maximizing the AC input range for applications where induced  $60\text{Hz}$  could reach amplitudes up to  $2\text{V}_{\text{RMS}}$ .

The circuits in Figures 45 and 47 could be used where multiple bridge circuits are involved and bridge output can be multiplexed onto a single LTC2411/LTC2411-1, via an inexpensive multiplexer such as the 74HC4052.

Figure 46 shows the use of an LTC2411/LTC2411-1 with a differential multiplexer. This is an inexpensive multiplexer that will contribute some error due to leakage if used directly with the output from the bridge, or if resistors are inserted as a protection mechanism from overvoltage. Although the bridge output may be within the input range of the A/D and multiplexer in normal operation, some thought should be given to fault conditions that could result in full excitation voltage at the inputs to the multiplexer or ADC. The use of amplification prior to the multiplexer will largely eliminate errors associated with channel leakage developing error voltages in the source impedance.

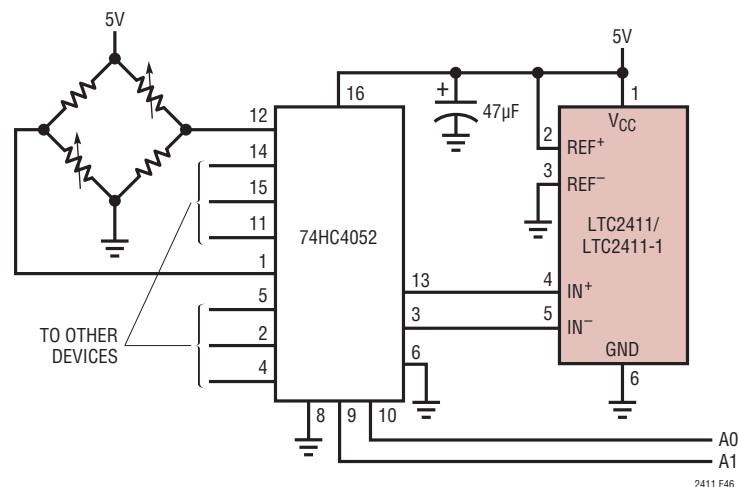

Figure 46. Use a Differential Multiplexer to Expand Channel Capability

## PACKAGE DESCRIPTION

Please refer to <http://www.linear.com/designtools/packaging/> for the most recent package drawings.

### MS Package 10-Lead Plastic MSOP

(Reference LTC DWG # 05-08-1661 Rev F)

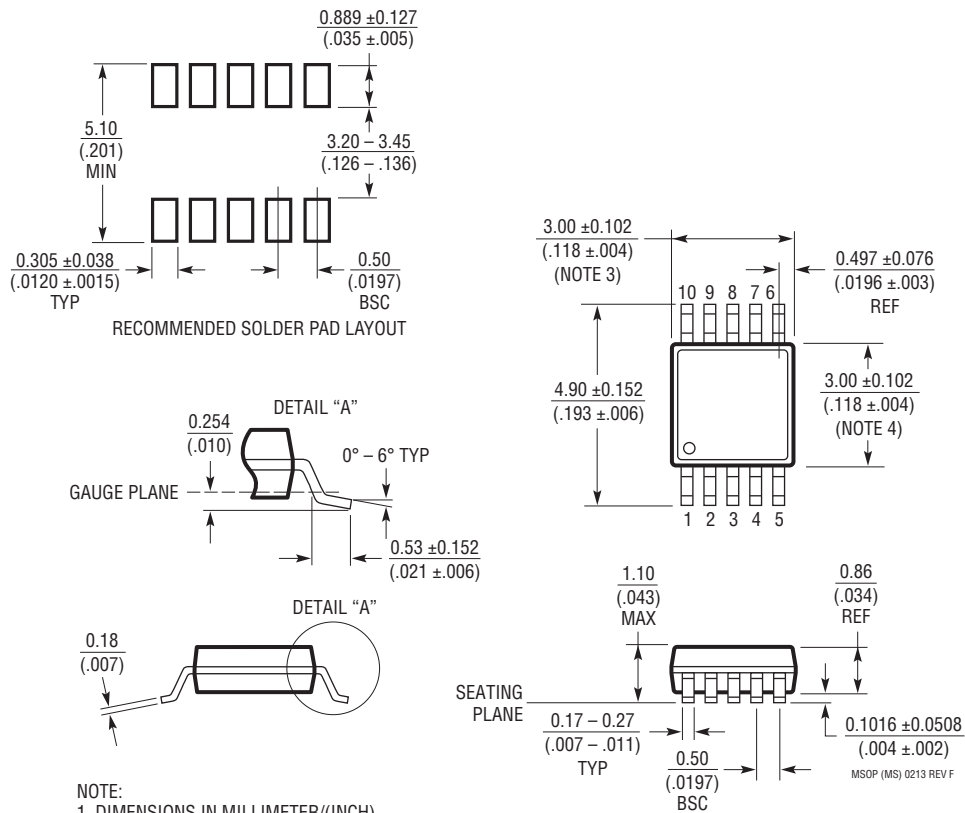

**NOTE:**

1. DIMENSIONS IN MILLIMETER/(INCH)
2. DRAWING NOT TO SCALE
3. DIMENSION DOES NOT INCLUDE MOLD FLASH, PROTRUSIONS OR GATE BURRS.  
MOLD FLASH, PROTRUSIONS OR GATE BURRS SHALL NOT EXCEED 0.152mm (.006") PER SIDE
4. DIMENSION DOES NOT INCLUDE INTERLEAD FLASH OR PROTRUSIONS.  
INTERLEAD FLASH OR PROTRUSIONS SHALL NOT EXCEED 0.152mm (.006") PER SIDE
5. LEAD COPLANARITY (BOTTOM OF LEADS AFTER FORMING) SHALL BE 0.102mm (.004") MAX

## REVISION HISTORY

REV	DATE	DESCRIPTION	PAGE NUMBER
A	08/15	Updated $f_{EOSC}$ maximum to 500kHz and all associated information.	5, 9, 28, 29, 30, 31

## TYPICAL APPLICATION

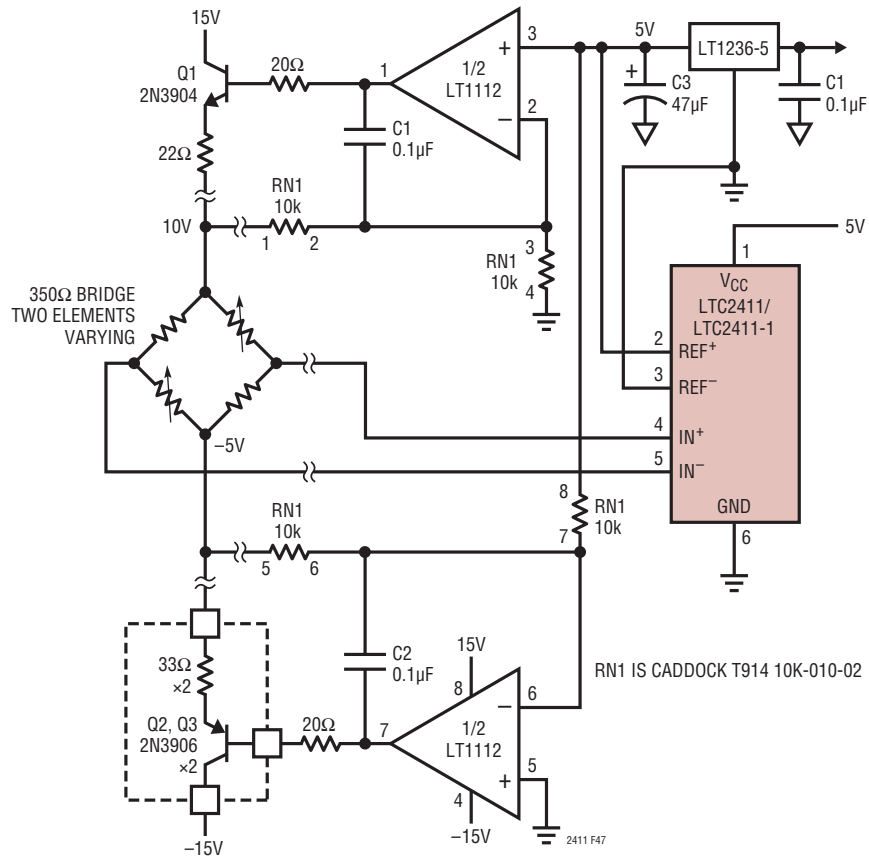

Figure 47. Use Resistor Arrays to Provide Precise Matching in Excitation Amplifier

## RELATED PARTS

PART NUMBER	DESCRIPTION	COMMENTS
<a href="#">LT1019</a>	Precision Bandgap Reference, 2.5V, 5V	3ppm/°C Drift, 0.05% Max Initial Accuracy
<a href="#">LT1025</a>	Micropower Thermocouple Cold Junction Compensator	80μA Supply Current, 0.5°C Initial Accuracy
<a href="#">LTC1050</a>	Precision Chopper Stabilized Op Amp	No External Components 5μV Offset, 1.6μV <sub>P-P</sub> Noise
<a href="#">LT1236A-5</a>	Precision Bandgap Reference, 5V	0.05% Max Initial Accuracy, 5ppm/°C Drift
<a href="#">LT1460</a>	Micropower Series Reference	0.075% Max Initial Accuracy, 10ppm/°C Max Drift
<a href="#">LTC2400</a>	24-Bit, No Latency ΔΣ ADC in SO-8	0.3ppm Noise, 4ppm INL, 10ppm Total Unadjusted Error, 200μA
<a href="#">LTC2401/LTC2402</a>	1-/2-Channel, 24-Bit, No Latency ΔΣ ADC in MSOP	0.6ppm Noise, 4ppm INL, 10ppm Total Unadjusted Error, 200μA
<a href="#">LTC2404/LTC2408</a>	4-/8-Channel, 24-Bit, No Latency ΔΣ ADC	0.3ppm Noise, 4ppm INL, 10ppm Total Unadjusted Error, 200μA
<a href="#">LTC2410</a>	24-Bit, Fully Differential, No Latency ΔΣ ADC	0.16ppm Noise, 2ppm INL, 10ppm Total Unadjusted Error, 200μA
<a href="#">LTC2413</a>	24-Bit, Fully Differential, No Latency ΔΣ ADC	Simultaneous 50Hz and 60Hz Rejection, 800nV <sub>RMS</sub> Noise
<a href="#">LTC2415</a>	24-Bit, No Latency ΔΣ ADC with 15Hz Output Rate	Pin Compatible with the LTC2410
<a href="#">LTC2420</a>	20-Bit, No Latency ΔΣ ADC in SO-8	1.2ppm Noise, 8ppm INL, Pin Compatible with LTC2400
<a href="#">LTC2424/LTC2428</a>	4-/8-Channel, 20-Bit, No Latency ΔΣ ADC	1.2ppm Noise, Pin Compatible with LTC2404/LTC2408

## Looking for pricing, stock, or lifecycle information?

Click below to explore more details on WIN SOURCE:

- ⊖ [View LTC2411-1IMS#PBF on WIN SOURCE](#)
- ⊖ [Analog Devices Inc. Information](#)

## Optimize Your Supply Chain with WIN SOURCE Solutions

- ✓ Global Sourcing Solution
- ✓ Obsolete Management
- ✓ Cost Control Management
- ✓ Shortage Management
- ✓ Alternative Solution
- ✓ Excess Inventory Management