



**THE DATASHEET OF
AD7380-4BCPZ**



Differential Input, Quad, External Reference Simultaneous Sampling, 16-BIT, SAR ADC

FEATURES

- ▶ 16-bit ADC family
- ▶ Quad simultaneous sampling
- ▶ Fully differential analog inputs
- ▶ High throughput rate: 4 MSPS
- ▶ SNR: 92 dB (typical) at $V_{REF} = 3.3\text{ V}$
- ▶ On-chip oversampling function
 - ▶ SNR: 97.7 dB (typical) with $OSR = 8\times$, $RES = 1$
- ▶ 2-bit resolution boost
- ▶ Out of range indicator (\overline{ALERT})
- ▶ INL: 3 LSBs (maximum)
- ▶ High-speed serial interface
- ▶ Temperature range: -40°C to $+125^{\circ}\text{C}$
- ▶ 4 mm × 4 mm, 24-lead LFCSP

APPLICATIONS

- ▶ Motor control position feedback
- ▶ Motor control current sense
- ▶ Data acquisition systems
- ▶ Erbium doped fiber amplifier (EDFA) applications
- ▶ In phase and quadrature demodulation

GENERAL DESCRIPTION

The AD7380-4 is a 16-bit compatible, quad, simultaneous sampling, high speed, successive approximation register (SAR), analog-to-digital converters (ADC) operating from a 3.3 V power supply with throughput rates up to 4 MSPS. The differential analog input accepts a wide common-mode input voltage and is sampled and converted on the falling edge of \overline{CS} .

The AD7380-4 has on-chip oversampling blocks to improve dynamic range and reduce noise at lower bandwidths. The oversampling can boost up to two bits of added resolution. The $REFIN$ pin can have a reference voltage of 2.5 V to 3.3 V.

The conversion process and data acquisition use standard control inputs allowing easy interfacing to microprocessors or digital signal processors (DSPs). The conversion result can clock out simultaneously via 4-wire mode for faster throughput or via 1-wire serial mode when slower throughput is allowed. The device is compatible with 1.8 V, 2.5 V, and 3.3 V interfaces using the separate logic supply.

The AD7380-4 is available in a [24-lead lead frame chip scale package \(LFCSP\)](#) and operates over a temperature range of -40°C to $+125^{\circ}\text{C}$.

FUNCTIONAL BLOCK DIAGRAM

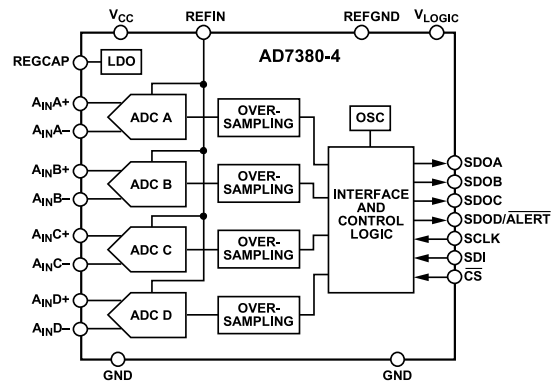

Figure 1.

Table 1. Related Devices

No. of Channels	Input Type	16 Bits	14 Bits	12 Bits
4	Differential	AD7380-4 AD7389-4	AD7381-4	
2	Differential	AD7380 AD4680 AD4681	AD7381	
	Single-ended	AD7386	AD7387	AD7388

PRODUCT HIGHLIGHTS

1. Quad simultaneous sampling and conversion
2. Pin-compatible product family.
3. High throughput rate, 4 MSPS at 16-bit.
4. Space-saving, 4 mm × 4 mm LFCSP.
5. Integrated oversampling block to increase dynamic range, reduce noise and reduce SCLK speed requirements.
6. Differential analog inputs with wide common-mode range.
7. Small sampling capacitor reduces amplifier drive burden.

Rev. A

DOCUMENT FEEDBACK

TECHNICAL SUPPORT

Information furnished by Analog Devices is believed to be accurate and reliable "as is". However, no responsibility is assumed by Analog Devices for its use, nor for any infringements of patents or other rights of third parties that may result from its use. Specifications subject to change without notice. No license is granted by implication or otherwise under any patent or patent rights of Analog Devices. Trademarks and registered trademarks are the property of their respective owners.

TABLE OF CONTENTS

Features.....	1	Resolution Boost.....	20
Applications.....	1	Alert.....	20
Functional Block Diagram.....	1	Power Modes.....	21
General Description.....	1	External Reference.....	21
Product Highlights.....	1	Software Reset.....	21
Specifications.....	3	Diagnostic Self Test.....	21
Timing Specifications.....	5	Interface.....	22
Absolute Maximum Ratings.....	8	Reading Conversion Results.....	22
Thermal Resistance.....	8	Low Latency Readback.....	23
Electrostatic Discharge (ESD) Ratings.....	8	Reading From Device Registers.....	24
ESD Caution.....	8	Writing to Device Registers.....	24
Pin Configuration and Function Descriptions.....	9	CRC.....	24
Typical Performance Characteristics.....	10	Registers.....	27
Terminology.....	13	Addressing Registers.....	27
Theory of Operation.....	14	Configuration 1 Register.....	28
Circuit Information.....	14	Configuration 2 Register.....	29
Converter Operation.....	14	Alert Indication Register.....	29
Analog Input Structure.....	14	Alert Low Threshold Register.....	30
ADC Transfer Function.....	15	Alert High Threshold Register.....	31
Applications Information.....	16	Outline Dimensions.....	32
Power Supply.....	16	Ordering Guide.....	32
Modes of Operation.....	18	Resolution Options.....	32
Oversampling.....	18	Evaluation Boards.....	32

REVISION HISTORY**4/2024—Rev. 0 to Rev. A**

Changes to Table 4.....	5
Changes to Figure 5.....	6
Changes to Power Supply Section.....	16
Moved Figure 30.....	17
Changes to Figure 30.....	17
Changes to Table 11.....	18
Added Resolution Options.....	32

1/2022—Revision 0: Initial Version

SPECIFICATIONS

$V_{CC} = 3.0\text{ V to }3.6\text{ V}$, $V_{LOGIC} = 1.65\text{ V to }3.6\text{ V}$, external reference voltage (V_{REF}) = 2.5 V, $f_{SAMPLE} = 4\text{ MSPS}$, $T_A = -40^\circ\text{C to }+125^\circ\text{C}$, no oversampling enabled, unless otherwise noted.

Table 2.

Parameter	Test Conditions/Comments	Min	Typ	Max	Unit
RESOLUTION		16			Bits
THROUGHPUT					
Conversion Rate (f_{SAMPLE})				4	MSPS
ANALOG INPUT					
Voltage Range	$A_{INX+} - A_{INX-}$	$-V_{REF}$		$+V_{REF}$	V
Absolute Input Voltage	A_{INX+} , A_{INX-}	-0.1		$V_{REF} + 0.1$	V
Common-Mode Input Range	A_{INX+} , A_{INX-}	0.2	$V_{REF} \times 0.5$	$V_{REF} - 0.2$	V
Analog Input Common-Mode Rejection Ratio (CMRR)	$f_{IN} = 500\text{ kHz}$		-76		dB
DC Leakage Current			0.1	1	μA
Input Capacitance	Track mode		18		pF
	Hold mode		5		pF
DC ACCURACY					
No Missing Codes		16			Bits
Differential Nonlinearity (DNL) Error		-1.0	± 0.5	+1.0	LSB
Integral Nonlinearity (INL) Error		-3.0	± 1	+3.0	LSB
Gain Error		-0.015	± 0.001	+0.015	% FS ¹
Gain Error Temperature Drift		-5	± 1	+5	ppm/ $^\circ\text{C}$
Gain Error Match		-0.015	± 0.01	+0.015	% FS
Offset Error		-0.75	± 0.1	+0.75	mV
Zero Error Temperature Drift		-1	± 0.5	+1	$\mu\text{V}/^\circ\text{C}$
Zero Error Match		-0.75	± 0.5	+0.75	mV
AC ACCURACY					
Dynamic Range	Input frequency (f_{IN}) = 1 kHz $V_{REF} = 3.3\text{ V}$		93		dB
			91.3		dB
Oversampled Dynamic Range	OSR = 4x, RES = 1 (decimal)		97.4		dB
Signal-to-Noise Ratio (SNR)	$V_{REF} = 3.3\text{ V}$	89	92		dB
		87.5	90.5		dB
	Rolling average OSR = 8x, RES = 1 (decimal)		97.7		dB
	$f_{IN} = 100\text{ kHz}$		89.2		dB
Spurious-Free Dynamic Range (SFDR)			-110		dB
Total Harmonic Distortion (THD)			-110		dB
	$f_{IN} = 100\text{ kHz}$		-104.7		dB
Signal-to-Noise-and-Distortion (SINAD) Ratio	$V_{REF} = 3.3\text{ V}$	88.5	91.5		dB
		87	90		dB
Channel to Channel Isolation			-126		dB
POWER SUPPLIES					
I_{VCC}					
Normal Mode (Operational)			38	42	mA
Power Dissipation					
P_{TOTAL}			163.1	180.2	mW
P_{VCC}					
Normal Mode (Operational)			136.8	151.2	mW

¹ These specifications include full temperature range variation, but they do not include the error contribution from the external reference.

SPECIFICATIONS

$V_{CC} = 3.0\text{ V to }3.6\text{ V}$, $V_{LOGIC} = 1.65\text{ V to }3.6\text{ V}$, external $V_{REF} = 2.5\text{ V}$, $T_A = -40^\circ\text{C to }+125^\circ\text{C}$, no oversampling enabled, unless otherwise noted.

Table 3.

Parameter	Test Conditions/Comments	Min	Typ	Max	Unit
SAMPLING DYNAMICS					
Input Bandwidth	At -0.1 dB		6.6		MHz
	At -3 dB		26.8		MHz
Aperture Delay			2		ns
Aperture Delay Match			46.8	145	ps
Aperture Jitter			20		ps
REFERENCE INPUT					
V_{REF} Input Voltage Range	External reference	2.49		3.4	V
V_{REF} Input Current	External reference		0.9	1.2	mA
DIGITAL INPUTS (SCLK, SDI, \overline{CS})					
Logic Levels					
Input Voltage Low (V_{IL})	$V_{LOGIC} < 2.3\text{ V}$			0.45	V
	$V_{LOGIC} \geq 2.3\text{ V}$			0.7	V
Input Voltage High (V_{IH})	$V_{LOGIC} < 2.3\text{ V}$	$V_{LOGIC} - 0.45\text{ V}$			V
	$V_{LOGIC} \geq 2.3\text{ V}$	$0.8 \times V_{LOGIC}$			V
Input Current Low (I_{IL})		-1		+1	μA
Input Current High (I_{IH})		-1		+1	μA
DIGITAL OUTPUTS (SDOA, SDOB, SDOC, SDOD/ALERT)					
Output Coding			Twos complement		Bits
Output Voltage Low (V_{OL})	Current sink (I_{SINK}) = 300 μA			0.4	V
Output Voltage High (V_{OH})	Current source (I_{SOURCE}) = -300 μA	$V_{LOGIC} - 0.3$			V
Floating State Leakage Current				± 1	μA
Floating State Output Capacitance			10		pF
POWER SUPPLIES					
V_{CC}	External reference = 3.3 V	3.0	3.3	3.6	V
		3.15	3.3	3.6	V
		1.65		3.6	V
V_{CC} Supply Current (I_{VCC})	Analog inputs at positive full scale	Normal Mode (Static)			mA
		1.7	2		
Shutdown Mode		101	200		μA
V_{LOGIC} Current (I_{VLOGIC})	Analog inputs at positive full scale	Normal Mode (Static)			nA
		10	200		
		Normal Mode (Operational)			mA
		7.3	8		
Shutdown Mode		10	200		nA
Power Dissipation					
V_{CC} Power (P_{VCC})	Analog inputs at positive full scale	Normal Mode (Static)			mW
		6.1	7.2		
Shutdown Mode		363.6	720		μW
V_{LOGIC} Power (P_{VLOGIC})	Analog inputs at positive full scale	Normal Mode (Static)			nW
		36	720		
		Normal Mode (Operational)			mW
		26.3	29		
Shutdown Mode		36	720		nW

SPECIFICATIONS

TIMING SPECIFICATIONS

$V_{CC} = 3.0\text{ V to }3.6\text{ V}$, $V_{LOGIC} = 1.65\text{ V to }3.6\text{ V}$, $V_{REF} = 2.5\text{ V}$, $T_A = -40^\circ\text{C to }+125^\circ\text{C}$, unless otherwise noted. When referencing a single function of a multifunction pin in the parameters, only the portion of the pin name that is relevant to the specification is listed, such as $\overline{\text{ALERT}}$. For full pin names of multifunction pins, refer to the [Pin Configuration and Function Descriptions](#) section.

Table 4.

Parameter	Min	Typ	Max	Unit	Description
t_{CYC}	250			ns	Time between conversions
t_{SCLKED}	5			ns	$\overline{\text{CS}}$ falling edge to first SCLK falling edge
t_{SCLK}	12.5			ns	SCLK period
t_{SCLKH}	5.5			ns	SCLK high time
t_{SCLKL}	5.5			ns	SCLK low time
t_{CSH}	20			ns	$\overline{\text{CS}}$ pulse width
t_{QUIET}	20			ns	Interface quiet time prior to conversion
t_{SDOEN}			5.5	ns	$\overline{\text{CS}}$ low to SDOA and SDOB enabled
t_{SDOH}	3			ns	SCLK rising edge to SDOA and SDOB hold time
t_{SDOS}			5	ns	SCLK rising edge to SDOA and SDOB setup time
t_{SDOT}			8	ns	$\overline{\text{CS}}$ rising edge to SDOA and SDOB high impedance
t_{SDIS}	4			ns	SDI setup time prior to SCLK falling edge
t_{SDIH}	4			ns	SDI hold time after SCLK falling edge
t_{SCLKCS}	0			ns	SCLK rising edge to $\overline{\text{CS}}$ rising edge
$t_{CONVERT}$			190	ns	Conversion time
$t_{ACQUIRE}$	110			ns	Acquire time
t_{RESET}		250		ns	Valid time to start conversion after soft reset
		800		ns	Valid time to start conversion after hard reset
$t_{POWERUP}$					Supply active to conversion
			5	ms	First conversion allowed
			5	ms	Settled to within 1% with external reference
$t_{REGWRITE}$			5	ms	Supply active to register read write access allowed
$t_{STARTUP}$					Exiting shutdown mode to conversion
			10	μs	Settled to within 1% with external reference
$t_{CONVERT0}$	6	8	10	ns	Conversion time for first sample in oversampling (OS) normal mode
$t_{CONVERTx}$		$t_{CONVERT0} + (500 \times (x - 1))$		ns	Conversion start time for x^{th} sample in OS normal mode
t_{ALERTS}			220	ns	Time from $\overline{\text{CS}}$ to $\overline{\text{ALERT}}$ indication
t_{ALERTC}			10	ns	Time from $\overline{\text{CS}}$ to $\overline{\text{ALERT}}$ clear
t_{ALERTS_NOS}			20	ns	Time from internal conversion with exceeded threshold to $\overline{\text{ALERT}}$ indication

SPECIFICATIONS

Timing Diagrams

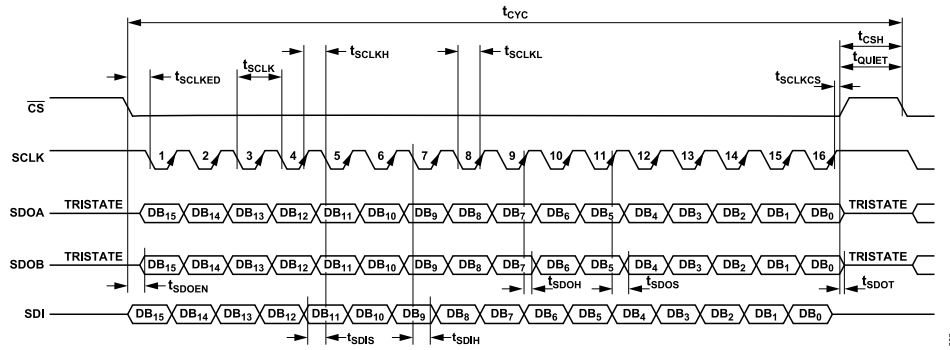

Figure 2. Serial Interface Timing Diagram

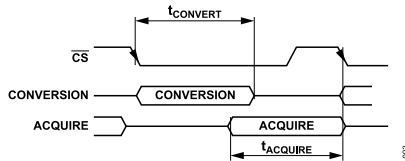

Figure 3. Internal Conversion Acquire Timing

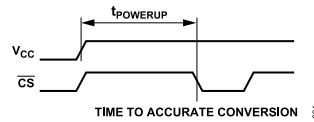

Figure 4. Power-Up Time to Conversion

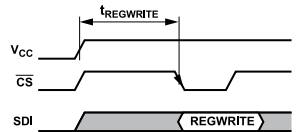

Figure 5. Power-Up Time to Register Read Write Access

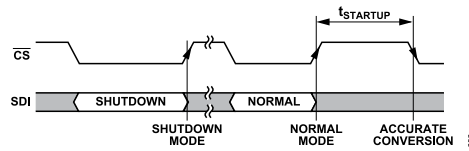

Figure 6. Shutdown Mode to Normal Mode Timing

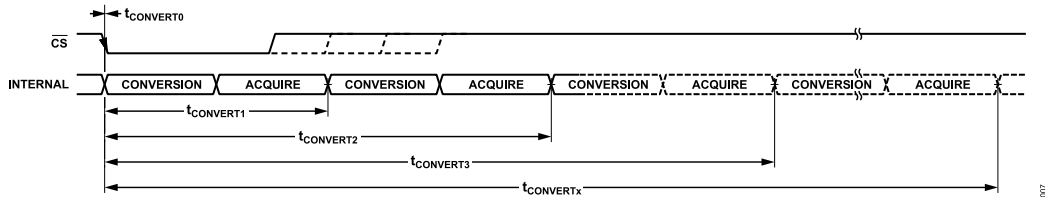

Figure 7. Conversion Timing During OS Normal Mode

SPECIFICATIONS

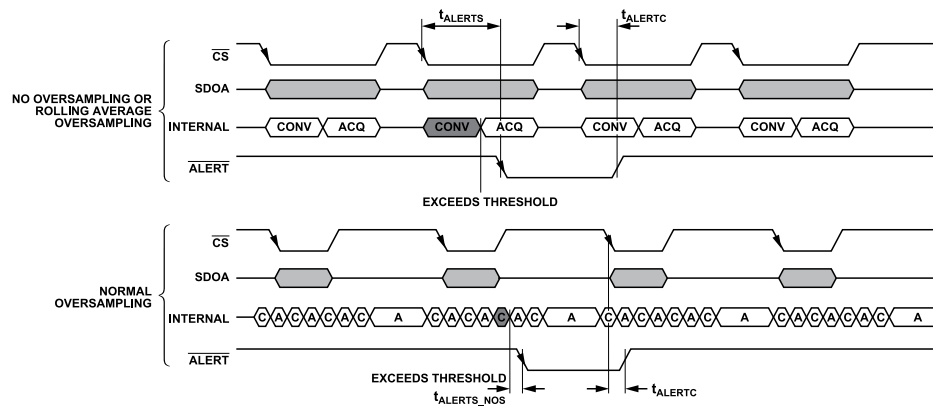

Figure 8. ALERT Timing

ABSOLUTE MAXIMUM RATINGS

Table 5.

Parameter	Rating
V_{CC} to GND	-0.3 V to +4 V
V_{LOGIC} to GND	-0.3 V to +4 V
Analog Input Voltage to GND	-0.3 V to $V_{REF} + 0.3$ V, or $V_{CC} + 0.3$ V
Digital Input Voltage to GND	-0.3 V to $V_{LOGIC} + 0.3$ V
Digital Output Voltage to GND	-0.3 V to $V_{LOGIC} + 0.3$ V
REFIN Input to GND	-0.3 V to $V_{CC} + 0.3$ V
Input Current to Any Pin Except Supplies	± 10 mA
Temperature	
Operating Temperature Range	-40°C to +125°C
Storage Temperature Range	-65°C to +150°C
Maximum Junction Temperature	150°C
Pb-Free Soldering Reflow Temperature	260°C

Stresses at or above those listed under Absolute Maximum Ratings may cause permanent damage to the product. This is a stress rating only; functional operation of the product at these or any other conditions above those indicated in the operational section of this specification is not implied. Operation beyond the maximum operating conditions for extended periods may affect product reliability.

THERMAL RESISTANCE

Thermal performance is directly linked to printed circuit board (PCB) design and operating environment. Careful attention to PCB thermal design is required.

θ_{JA} is the natural convection junction to ambient thermal resistance measured in a one cubic foot sealed enclosure. θ_{JC} is the junction to case thermal resistance.

Table 6. Thermal Resistance

Package Type	θ_{JA}	θ_{JC}	Unit
CP-24-25 ¹	48.4	0.43 ²	°C/W

¹ Test Condition 1: thermal impedance simulated values are based on JEDEC 2S2P thermal test board with four thermal vias. See JEDEC JESDS1.

² Test Condition 2: a cold plate attached to the package surface and measured at the exposed pad.

ELECTROSTATIC DISCHARGE (ESD) RATINGS

The following ESD information is provided for handling of ESD-sensitive devices in an ESD protected area only.

Human body model (HBM) per ANSI/ESDA/JEDEC JS-001.

Field induced charge device model (FICDM) per ANSI/ESDA/JEDEC JS-002.

ESD Ratings for AD7380-4

Table 7. AD7380-4, 24-lead LFCSP

ESD Model	Withstand Threshold (V)	Class
HBM	± 4000	3A
FICDM	± 1250	C3

ESD CAUTION



ESD (electrostatic discharge) sensitive device. Charged devices and circuit boards can discharge without detection. Although this product features patented or proprietary protection circuitry, damage may occur on devices subjected to high energy ESD. Therefore, proper ESD precautions should be taken to avoid performance degradation or loss of functionality.

PIN CONFIGURATION AND FUNCTION DESCRIPTIONS

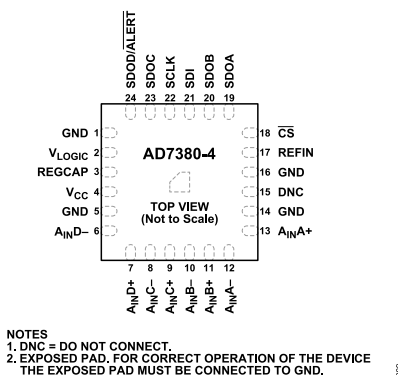

Figure 9. Pin Configuration

Table 8. Pin Function Descriptions

Pin No.	Mnemonic	Description
1, 5, 14, 16	GND	Ground Reference Point. These pins are the ground reference points for all circuitry on the device.
2	V _{LOGIC}	Logic Interface Supply Voltage, 1.65 V to 3.6 V. Decouple this pin to GND with a 1 μ F capacitor.
3	REGCAP	Decoupling Capacitor Pin for Voltage Output from Internal Regulator. Decouple this pin to GND with a 1 μ F capacitor. The voltage at this pin is 1.9 V typical.
4	V _{CC}	Power Supply Input Voltage. 3.0 V to 3.6 V. Decouple this pin to GND using a 1 μ F capacitor.
6, 7	A _{IND} -, A _{IND} +	Analog Inputs of ADC D. These analog inputs form a fully differential pair.
8, 9	A _{INC} -, A _{INC} +	Analog Inputs of ADC C. These analog inputs form a fully differential pair.
10, 11	A _{INB} -, A _{INB} +	Analog Inputs of ADC B. These analog inputs form a fully differential pair.
12, 13	A _{INA} -, A _{INA} +	Analog Inputs of ADC A. These analog inputs form a fully differential pair.
15	DNC	Do Not Connect.
17	REFIN	Reference Input. An external reference of 2.5 V to 3.3 V can be input to this pin. Decoupling is required on this pin. Apply a 1 μ F capacitor from this pin to GND.
18	$\overline{\text{CS}}$	Chip Select Input. Active low, logic input. This input provides the dual function of initiating conversions on the AD7380-4 and framing the serial data transfer.
19	SDOA	Serial Data Output A. This pin functions as a serial data output pin to access the conversion results and register contents.
20	SDOB	Serial Data Output B. This pin functions as a serial data output pin to access the conversion results.
21	SDI	Serial Data Input. This input provides the data written to the on-chip control registers.
22	SCLK	Serial Clock Input. This serial clock input is for data transfers to and from the ADC.
23	SDOC	Serial Data Output C. This pin functions as a serial data output pin to access the conversion results and register contents.
24	SDOD/ $\overline{\text{ALERT}}$	Serial Data Output D/Alert Indication Output. This pin can operate as a serial data output pin or alert indication output. SDOD. This pin functions as a serial data output pin to access the conversion results. $\overline{\text{ALERT}}$. This pin operates as an alert pin going low to indicate that a conversion result has exceeded a configured threshold.
Not applicable	EPAD	Exposed Pad. For correct operation of the device, the exposed pad must be connected to GND.

TYPICAL PERFORMANCE CHARACTERISTICS

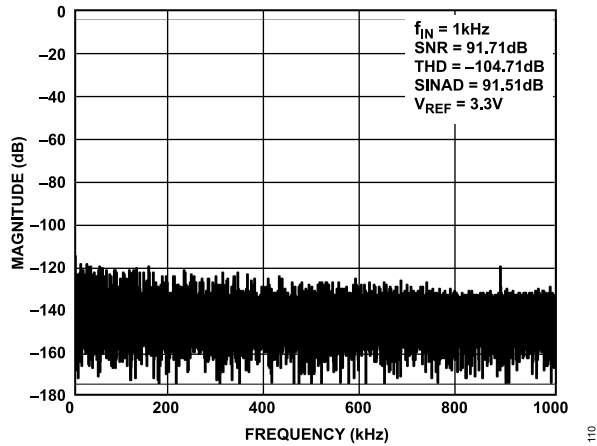

Figure 10. Fast Fourier Transform (FFT), External Reference Voltage = 3.3 V

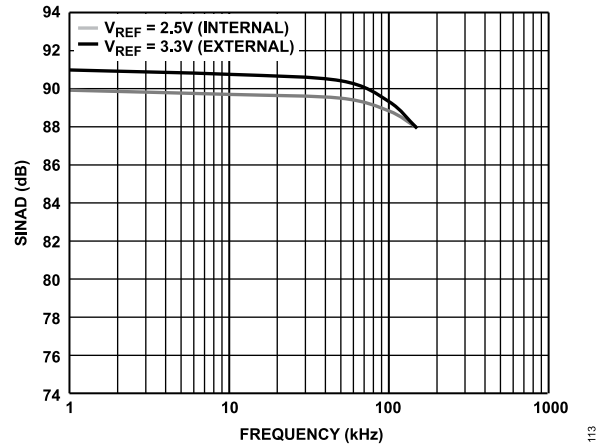

Figure 13. SINAD vs. Frequency

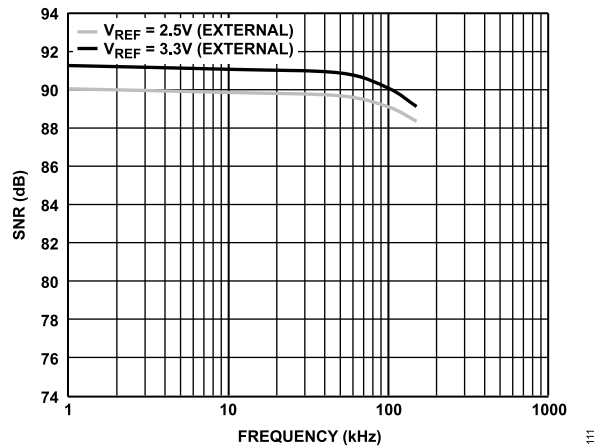

Figure 11. SNR vs. Frequency

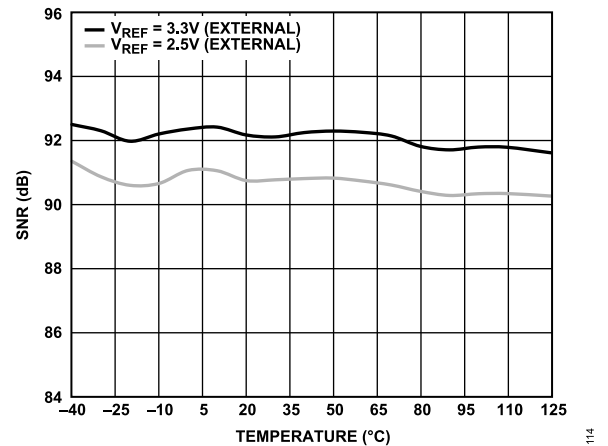

Figure 14. SNR vs. Temperature

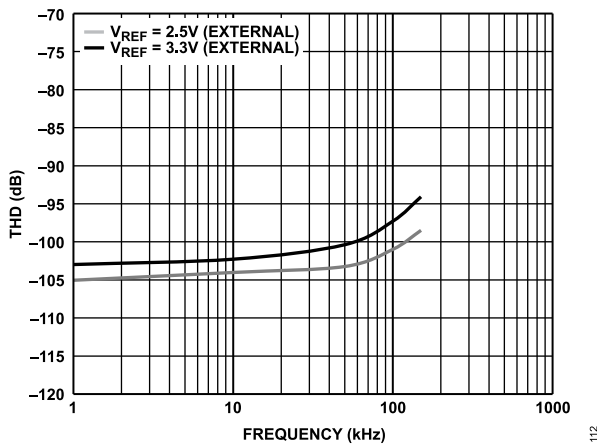

Figure 12. THD vs. Frequency

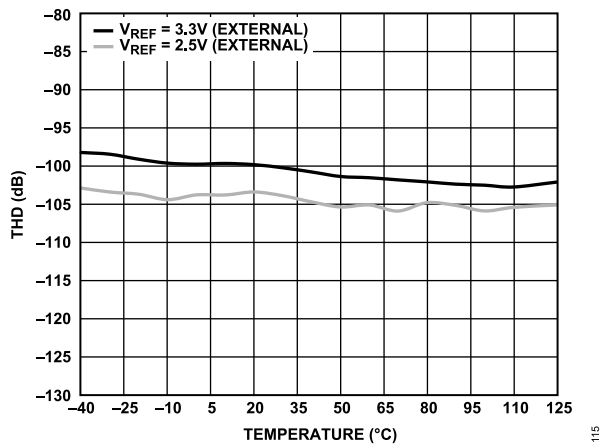

Figure 15. THD vs. Temperature

TYPICAL PERFORMANCE CHARACTERISTICS

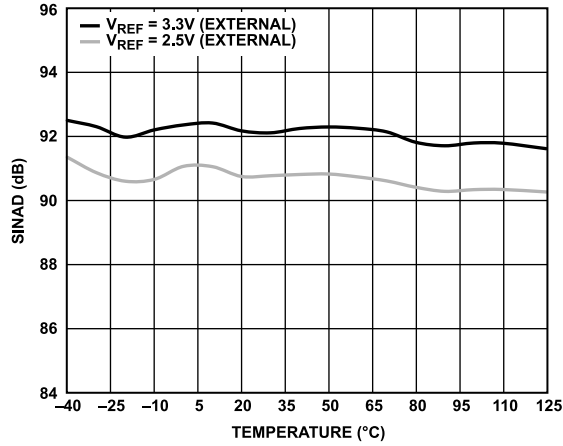

Figure 16. SINAD vs. Temperature

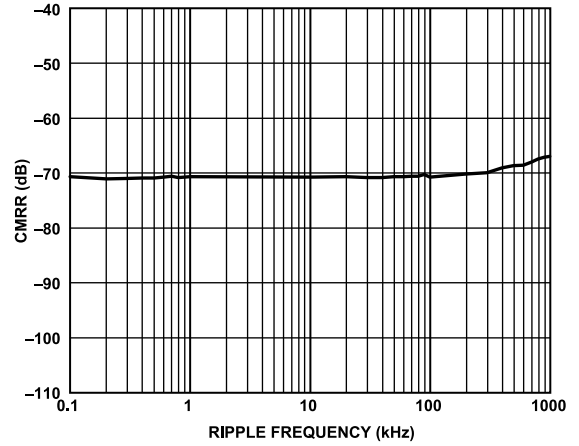

Figure 19. CMRR vs. Ripple Frequency

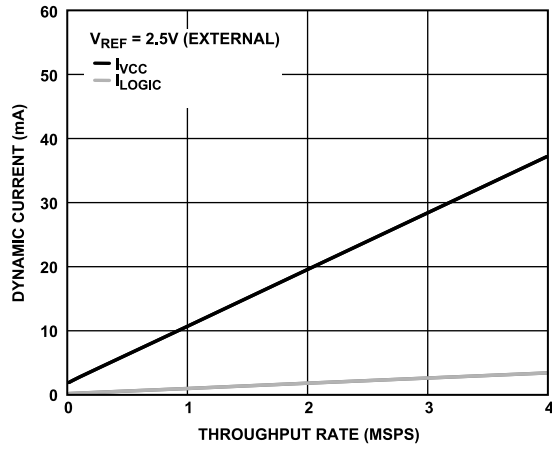

Figure 17. Dynamic Current vs. Throughput Rate

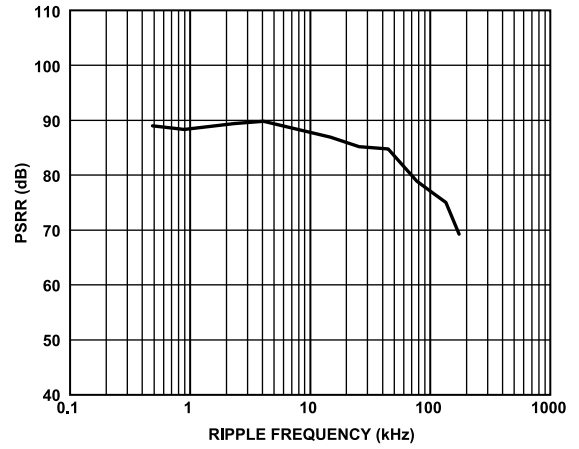

Figure 20. PSRR vs. Ripple Frequency

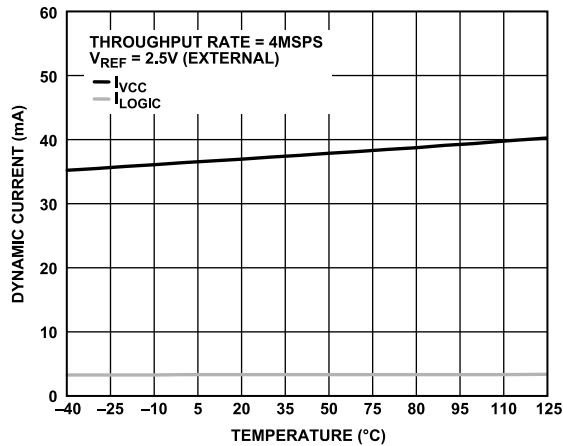

Figure 18. Dynamic Current vs. Temperature

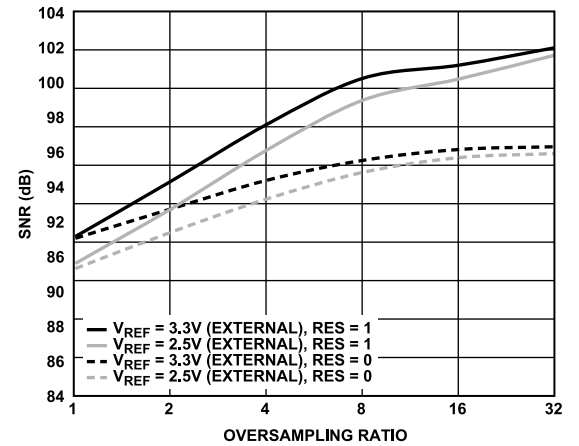

Figure 21. Normal Averaging Oversampling

TYPICAL PERFORMANCE CHARACTERISTICS

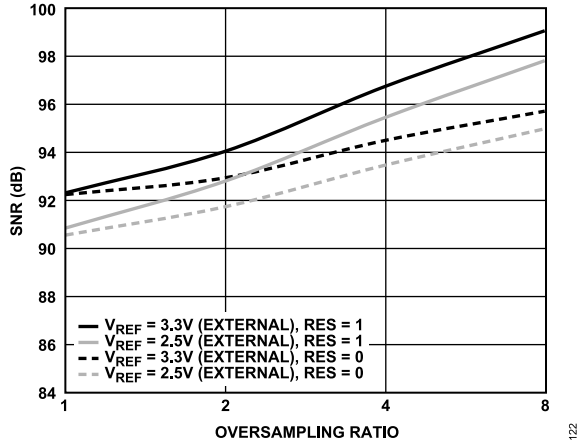

Figure 22. Rolling Average Oversampling

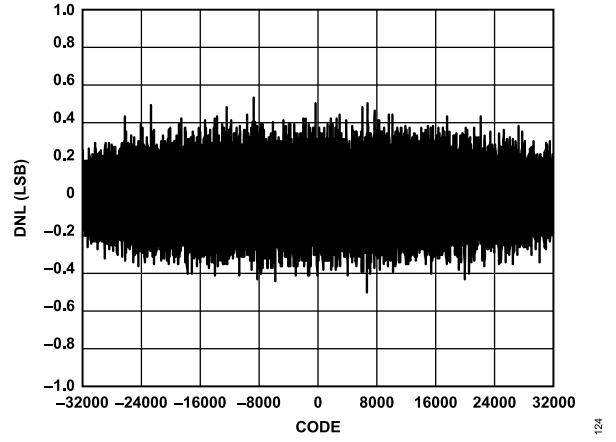

Figure 24. DNL vs. Code

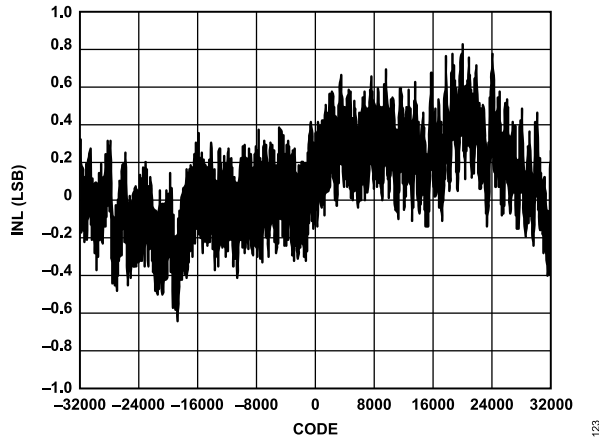

Figure 23. INL vs. Code

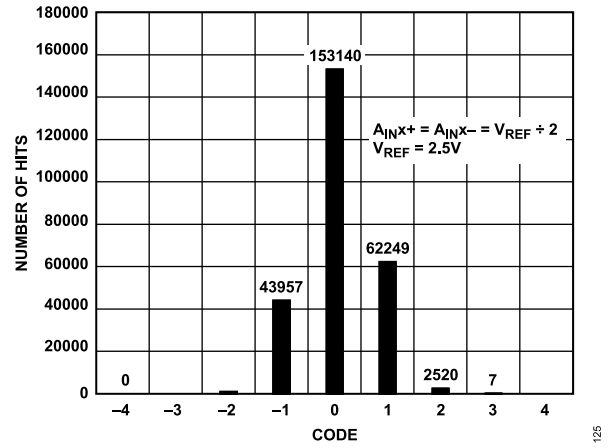

Figure 25. Histogram

TERMINOLOGY

Differential Nonlinearity (DNL)

In an ideal ADC, code transitions are 1 LSB apart. DNL is the maximum deviation from this ideal value. DNL is often specified in terms of resolution for which no missing codes are guaranteed.

Integral Nonlinearity (INL)

INL is the deviation of each individual code from a line drawn from negative full scale through positive full scale. The point used as negative full scale occurs $\frac{1}{2}$ LSB before the first code transition. Positive full scale is defined as a level $1\frac{1}{2}$ LSB beyond the last code transition. The deviation is measured from the middle of each code to the true straight line.

Gain Error

The first transition (from 100 ... 000 to 100 ... 001) occurs at a level $\frac{1}{2}$ LSB above nominal negative full scale. The last transition (from 011 ... 110 to 011 ... 111) occurs for an analog voltage $1\frac{1}{2}$ LSB below the nominal full scale. The gain error is the deviation of the difference between the actual level of the last transition and the actual level of the first transition from the difference between the ideal levels.

Gain Error Drift

The gain error change due to a temperature change of 1°C.

Gain Error Matching

Gain error matching is the difference in negative full-scale error between the input channels and the difference in positive full-scale error between the input channels.

Zero Error

Zero error is the difference between the ideal midscale voltage, 0 V, and the actual voltage producing the midscale output code, 0 LSB.

Zero Error Temperature Drift

Zero error temperature drift is the zero error change due to a temperature change of 1°C.

Zero Error Match

Zero error match is the difference in zero error between the input channels.

Signal-to-Noise Ratio (SNR)

SNR is the ratio of the rms value of the actual input signal to the rms sum of all other spectral components below the Nyquist frequency, excluding harmonics and dc. The value for SNR is expressed in decibels.

Spurious-Free Dynamic Range (SFDR)

SFDR is the difference, in decibels, between the rms amplitude of the input signal and the peak spurious signal.

Total Harmonic Distortion (THD)

THD is the ratio of the rms sum of the first five harmonic components to the rms value of a full-scale input signal and is expressed in decibels.

Signal-to-Noise-and-Distortion (SINAD) Ratio

SINAD is the ratio of the rms value of the actual input signal to the rms sum of all other spectral components that are less than the Nyquist frequency, including harmonics but excluding dc. The value for SINAD is expressed in decibels.

Common-Mode Rejection Ratio (CMRR)

CMRR is the ratio of the power in the ADC output at the frequency, f , to the power of a 200 mV p-p sine wave applied to the common-mode voltage of A_{INx+} and A_{INx-} of frequency, f . CMRR is expressed in decibels.

$$CMRR = 10\log(P_{ADC_IN}/P_{ADC_OUT}) \quad (1)$$

where:

P_{ADC_IN} is the common-mode power at the frequency, f , applied to the A_{INx+} and A_{INx-} inputs.

P_{ADC_OUT} is the power at the frequency, f , in the ADC output.

Aperture Delay

Aperture delay is the measure of the acquisition performance and is the time between the falling edge of the \overline{CS} input and when the input signal is held for a conversion.

Aperture Jitter

Aperture jitter is the variation in aperture delay.

THEORY OF OPERATION

CIRCUIT INFORMATION

The AD7380-4 is a high speed, quad, fully differential 16-bit, SAR analog-to-digital converters. The device operates from a 3.0 V to 3.6 V power supply and features throughput rates up to 4 MSPS.

The AD7380-4 contains four successive approximation ADCs, and a serial interface with four separate data output pins. The device is housed in a 24-lead LFCSP, offering the user considerable space-saving advantages over alternative solutions.

Data is accessed from the device via the serial interface. The interface can be operated with two, four or one serial outputs. The AD7380-4 uses an external reference voltage value ranging from 2.5 V to V_{CC} . The differential analog input range for the AD7380-4 is $V_{CM} \pm V_{REF}/2$.

The AD7380-4 features on-chip oversampling blocks to improve performance. Normal averaging and rolling average oversampling modes are available. Power-down options to allow power saving between conversions are available. Configuration of the device is implemented via the standard serial interface, as described in the [Interface](#) section.

CONVERTER OPERATION

The AD7380-4 has four successive approximation ADCs, each based around two capacitive DACs. [Figure 26](#) and [Figure 27](#) show simplified schematics of one of these ADCs in acquisition and conversion phases, respectively. The ADC comprises control logic, a SAR, and two capacitive DACs. In [Figure 26](#) (the acquisition phase), SW3 is closed, SW1 and SW2 are in Position A, the comparator is held in a balanced condition, and the sampling capacitor (C_S) arrays can acquire the differential signal on the input.

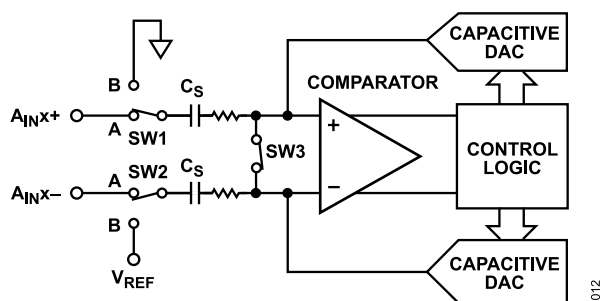

Figure 26. ADC Acquisition Phase

When the ADC starts a conversion (see [Figure 27](#)), SW3 opens and SW1 and SW2 move to Position B, causing the comparator to become unbalanced. Both inputs are disconnected when the conversion begins. The control logic and charge redistribution DACs are used to add and subtract fixed amounts of charge from the sampling capacitor arrays to bring the comparator back into a balanced condition. When the comparator is rebalanced, the conversion is complete. The control logic generates the ADC output code. The output impedances of the sources driving the A_{INX+}

and A_{INX-} pins must be matched. Otherwise, the two inputs have different settling times, resulting in errors.

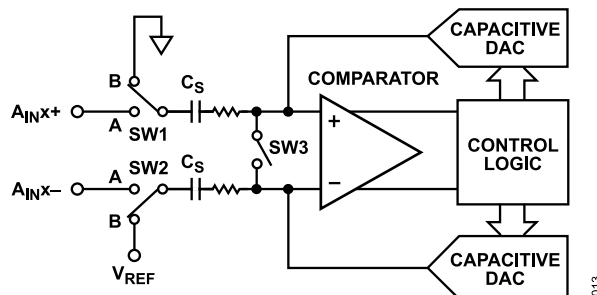

Figure 27. ADC Conversion Phase

ANALOG INPUT STRUCTURE

[Figure 28](#) shows the equivalent circuit of the analog input structure of the AD7380-4. The four diodes provide ESD protection for the analog inputs. Ensure that the analog input signals never exceed the supply rails by more than 300 mV. Exceeding the limit causes these diodes to become forward-biased and start conducting into the substrate. These diodes can conduct up to 10 mA without causing irreversible damage to the device.

The C1 capacitors in [Figure 28](#) are typically 3 pF and can primarily be attributed to pin capacitance. The R1 resistors are lumped components made up of the on resistance of the switches. The value of these resistors is typically about 200 Ω . The C2 capacitors are the ADC sampling capacitors with a typical capacitance of 15 pF.

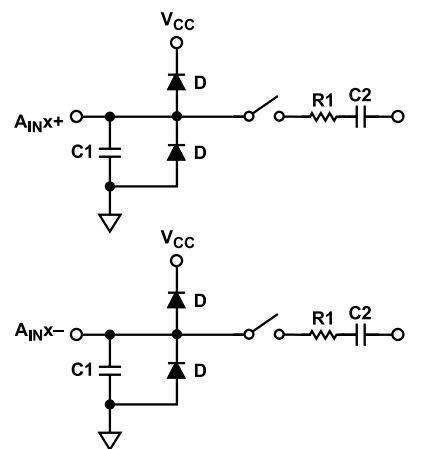

Figure 28. Equivalent Analog Input Circuit, Conversion Phase—Switches Open, Track Phase—Switches Closed

THEORY OF OPERATION

ADC TRANSFER FUNCTION

The AD7380-4 uses a 2.5 V to 3.3 V reference. The AD7380-4 converts the differential voltage of the analog inputs (A_{IN+} and A_{IN-}) into a digital output.

The conversion result is MSB first, twos complement. The LSB size is $(2 \times V_{REF})/2^N$, where N is the ADC resolution. The ADC resolution is determined by the resolution of the device chosen and if resolution boost mode is enabled. Table 9 outlines the LSB size expressed in microvolts for different resolutions and reference voltage options.

The ideal transfer characteristic of the AD7380-4 is shown in Figure 29.

Table 9. LSB Size

Resolution (Bits)	2.5 V Reference (μ V)	3.3 V Reference (μ V)
16	76.3	100.7
18	19.1	25.2

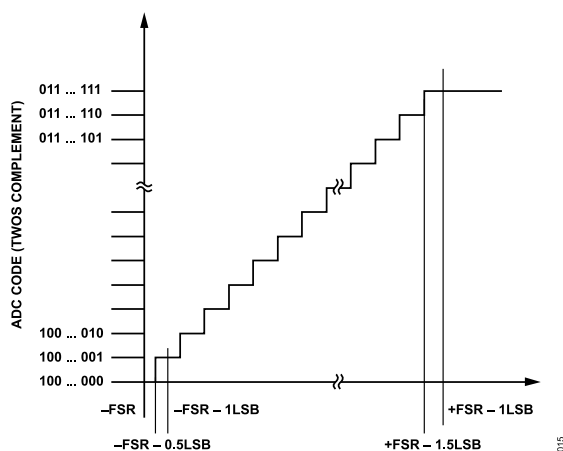

Figure 29. ADC Ideal Transfer Function (FSR = Full-Scale Range)

APPLICATIONS INFORMATION

Figure 30 shows an example of a typical application circuit for the AD7380-4. Decouple the V_{CC} , V_{LOGIC} , REGCAP, and REFIN pins with suitable decoupling capacitors as shown. The exposed pad is a ground reference point for circuitry on the device and must be connected to the board ground.

A differential RC filter must be placed on the analog inputs to ensure optimal performance is achieved. In a typical application, $R = 33 \Omega$, $C1 = 68 \text{ pF}$, and $C2 = 68 \text{ pF}$ are recommended. These RC combinations must be the same for all channels of the AD7380-4.

The four differential channels of the AD7380-4 can accept an input voltage range from 0 V to V_{REF} and have a wide common-mode range to convert a variety of signals. These analog input pins ($A_{INX\pm}$) can easily be driven with an amplifier. See Table 10 for the recommended driver amplifiers that can best fit and add value to the application.

The performance of the AD7380-4 can be impacted by noise on the digital interface. This impact is dependent on board layout and design. Keep a minimal distance of the digital line to the digital interface or place a 100Ω resistor in series and close to the SDOA, SDOB, SDOC, and SDOD/ALERT pins to reduce noise from the digital interface coupling of the AD7380-4.

The reference voltage of the AD7380-4 ranges from 2.5 V to 3.3 V. The ADR4533 or ADR4525 is an ultralow noise, high accuracy voltage reference recommended to drive the AD7380-4 REFIN pin. A $1 \mu\text{F}$ reservoir capacitor is recommended to be connected between the REFIN pin and the ground. When using this external reference voltage in another circuit within the application, for example, as a common-mode voltage for the driver amplifier, it is recommended to use a buffer amplifier like the ADA4807-2 for a stable reference.

POWER SUPPLY

For a typical application, the AD7380-4 circuitry shown in Figure 30 can be driven from a 5 V ($V+$) supply to power the system.

The 5 V ($V+$) can be supplied from the ADP7104. The ADC driver can be supplied by a 5 V ($V+$) and a -2.5 V ($V-$) derived from the inverting charge pump, the ADP5600, that converts 5 V to -5 V , then to the ADP7182 for the low noise voltage regulator to output -2.5 V . Two independent power supply sources are derived from a low dropout (LDO) regulator to power the V_{CC} supply for the analog circuitry and the V_{LOGIC} supply for the digital interface of the AD7380-4. A very low quiescent current LDO regulator like the ADP166 is a suitable supply with a fixed output voltage range from 1.2 V to 3.3 V for typical V_{CC} and V_{LOGIC} levels. The V_{CC} supply and the V_{LOGIC} supply must be decoupled separately with a $1 \mu\text{F}$ capacitor, placed close to the device pin using short and wide traces to provide a low impedance path that reduces glitches in the power supply lines. Additionally, an LDO regulator supplies the AD7380-4. The on-chip regulator provides a 1.9 V supply only for internal use on the device. Decouple the AD7380-4 REGCAP pin with a $1 \mu\text{F}$ capacitor to the GND pin with short and wide traces, and place the capacitor as close as possible to the REGCAP pin of the device.

Power-Up

The AD7380-4 is not easily damaged by power supply sequencing. V_{CC} and V_{LOGIC} can be applied in any sequence. The external reference must be applied after V_{CC} and V_{LOGIC} are applied. Analog and digital signals must be applied after the external reference is applied.

The AD7380-4 requires $t_{POWERUP}$ from applying V_{CC} and V_{LOGIC} until the ADC conversion results are stable. Interfacing with the AD7380-4 prior to the setup time elapsing does not have a negative impact on ADC operation. See Figure 4 for the recommended signal condition during power-up. Issuing a reset is a good practice after power-up. It is recommended to initiate software hard reset once V_{CC} and V_{LOGIC} supplies are on correct voltage levels (see the Software Reset section for details).

Table 10. Signal Chain Components

Companion Devices	Part Name	Description	Typical Application
ADC Driver	ADA4896-2	1 nV/ $\sqrt{\text{Hz}}$, rail to rail output amplifier	Precision, low noise, high frequency
	ADA4940-2	Ultra low power, full differential, low distortion amplifier	Precision, low density, low power
	ADA4807-2	1 mA, rail to rail output amplifier	Precision, low power, high frequency
External Reference	ADR4525	Ultralow noise, high accuracy voltage reference	2.5 V reference voltage
	ADR4533	Ultralow noise, high accuracy voltage reference	3.3 V reference voltage
Reference Buffer	ADA4807-2	1 mA, rail to rail output amplifier	Precision, low power, high frequency
LDO Regulator	ADP166	Very low quiescent, 150 mA LDO regulator	3.0 V to 3.6 V supply for V_{CC} and V_{LOGIC}
	ADP7104	500 mA low noise, CMOS LDO regulator	5 V supply
	ADP7182	Low noise line regulator	-2.5 V supply for ADC driver amplifier
	ADP5600	Interleaved inverting charge pump with negative LDO	Voltage inverter for negative supply

APPLICATIONS INFORMATION

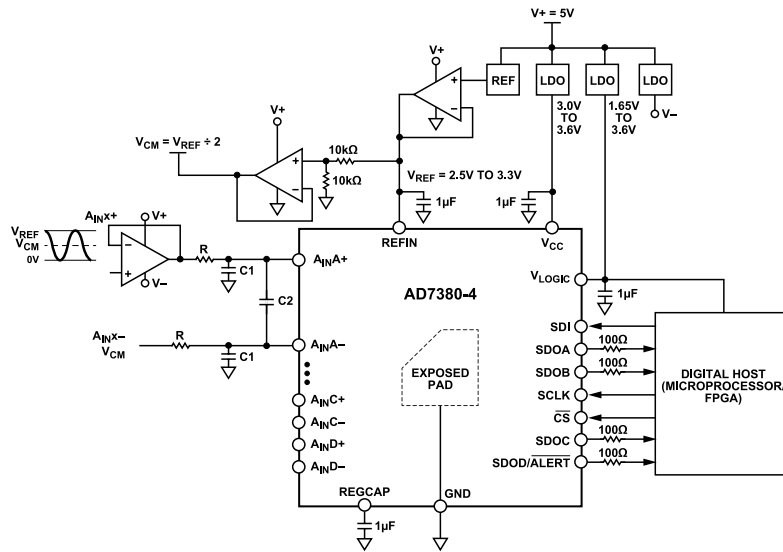

- NOTES
1. V- IS THE EXTERNAL SUPPLY VOLTAGE (-2.5V) FOR THE DRIVER AMPLIFIER.
 2. PLACE DECOUPLING CAPACITORS CLOSE TO (IDEALLY, RIGHT UP AGAINST) THE DEVICE SUPPLY PINS AND REFERENCE PIN.

01E

Figure 30. Typical Application Circuit

MODES OF OPERATION

The AD7380-4 has several on-chip configuration registers for controlling the operational mode of the device.

OVERSAMPLING

Oversampling is a common method used in analog electronics to improve the accuracy of the ADC result. Multiple samples of the analog input are captured and averaged to reduce the noise component from quantization noise and thermal noise (kTC noise) of the ADC. The AD7380-4 offers an oversampling function on-chip. The AD7380-4 has two user configurable oversampling modes: normal averaging and rolling average.

The oversampling functionality is configured by programming the OS_MODE bit and OSR bits in the Configuration 1 register.

Normal Averaging Oversampling

Normal averaging oversampling mode can be used in applications where slower output data rates are allowed and where higher SNR or dynamic range is desirable. Normal averaging involves taking a number of samples, adding them together and dividing the result by the number of samples taken. This result is then output from the device. The sample data is cleared when the process completes.

Normal averaging oversampling mode is configured by setting the OS_MODE bit to Logic 0 and having a valid nonzero value in the

OSR bits. The oversampling ratio of the digital filter is controlled using the oversampling bits, OSR (see Table 11).

Table 11 provides the oversampling bit decoding to select the different oversample rates. The output result is decimated to 16-bit resolution. If required, additional resolution can be achieved by configuring the resolution boost bit (RES) in the Configuration 1 register. See the Resolution Boost section for further details.

The number of samples (n), defined by the OSR bits, are taken and added together, and the result is divided by n. The initial ADC conversion is initiated by the falling edge of \overline{CS} and the AD7380-4 controls all subsequent samples in the oversampling sequence internally. The sampling rate of the additional n samples at the device maximum sampling rate is 2 MSPS. The data is ready for readback on the next serial interface access. After the averaging technique is applied, the sample data used in the calculation is discarded. This process is repeated every time the application needs a new conversion result and is initiated by the next falling edge of \overline{CS} .

As the output data rate is reduced by the oversampling ratio, the serial peripheral interface (SPI) frequency required to transmit the data is reduced accordingly.

Table 11. Normal Averaging Oversampling Overview

OSR, Bits[2:0]	OS Ratio	SNR (dB Typical)				Data Output Rate (kSPS Maximum)
		2.5 V External Reference		3.3 V External Reference		
		RES = 0	RES = 1	RES = 0	RES = 1	
000	No OS	90.8	90.8	92.5	92.5	4000
001	2	92	93	94	95.5	1000
010	4	94	96.5	95.2	98.2	500
011	8	95.8	99.2	96.3	100.5	250
100	16	96.3	100.4	96.8	101.2	125
101	32	96	101.2	97	102.2	62.5
110	Invalid	Not applicable	Not applicable	Not applicable	Not applicable	Not applicable
111	Invalid	Not applicable	Not applicable	Not applicable	Not applicable	Not applicable

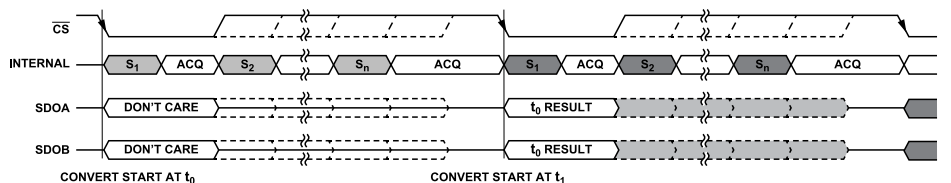

Figure 31. Normal Averaging Oversampling Operation

MODES OF OPERATION

Rolling Average Oversampling

Rolling average oversampling mode can be used in applications where higher output data rates are required and where a higher SNR or dynamic range is desirable. Rolling averaging involves taking a number of samples, adding them together, and dividing the result by the number of samples taken. This result is then output from the device. The sample data is not cleared when the process completes. The rolling oversampling mode uses a first in, first out (FIFO) buffer of the most recent samples in the averaging calculation, allowing the ADC throughput rate and output data rate to stay the same.

Rolling average oversampling mode is configured by setting the OS_MODE bit to Logic 1 and having a valid nonzero value in the OSR bits. The oversampling ratio of the digital filter is controlled using the oversampling bits, OSR (see Table 12).

Table 12 provides the oversampling bit decoding to select the different oversample rates. The output result is decimated to 16-bit

resolution for the AD7380-4. If required, additional resolution can be achieved by configuring the resolution boost bit in the CONFIGURATION 1 register. See the Resolution Boost section for further details.

In rolling average oversampling mode, all ADC conversions are controlled and initiated by the falling edge of \overline{CS} . When a conversion is complete, the result is loaded into the FIFO. The FIFO length is 8, regardless of the oversampling ratio set. The FIFO is filled on the first conversion after a power-on reset (POR), on the first conversion after a software controlled hard or soft reset. A new conversion result is shifted into the FIFO on completion of every ADC conversion regardless of the status of the OSR bits and the OS_MODE bit. This conversion allows a seamless transition from no oversampling to rolling average oversampling, or different rolling average oversampling ratios without waiting for the FIFO to fill.

The number of samples, n, defined by the OSR bits are taken from the FIFO, added together and the result is divided by n.

Table 12. Rolling Average Oversampling Overview

OSR, Bits[2:0]	OS Ratio	SNR (dB Typical)				Data Output Rate (kSPS Maximum)
		2.5 V External Reference		3.3 V External Reference		
		RES = 0	RES = 1	RES = 0	RES = 1	
000	No oversampling	91	91	92.5	92.5	4000
001	2	92	93	93	94	4000
010	4	94	95.4	95	97	4000
011	8	95.5	98	97	99	4000
110	Invalid	Not applicable	Not applicable	Not applicable	Not applicable	Not applicable
111	Invalid	Not applicable	Not applicable	Not applicable	Not applicable	Not applicable

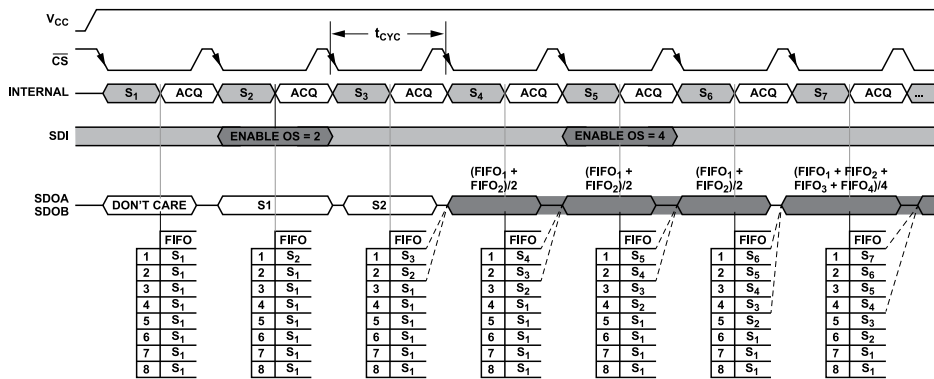

Figure 32. Rolling Average Oversampling Mode Configuration

MODES OF OPERATION

RESOLUTION BOOST

The default resolution and output data size for the AD7380-4 is 16 bits. When the on-chip oversampling function is enabled the performance of the ADC can exceed the default resolution. To accommodate the performance boost achievable, it is possible to enable an additional two bits of resolution. If the RES bit in the CONFIGURATION 1 register is set to Logic 1 and the AD7380-4 is in a valid oversampling mode, the conversion result size for the AD7380-4 is 18 bits. In this mode, 18 SCLK cycles are required to propagate the data for the AD7380-4.

ALERT

The alert functionality is an out of range indicator and can be used as an early indicator of an out of bounds conversion result. An alert event triggers when the value in the conversion result register exceeds the alert high limit value in the alert high threshold register or falls below the alert low limit value in the alert low threshold register. The alert high threshold register and the alert low threshold register are common to all ADCs. When setting the threshold limits, the alert high threshold must always be greater than the alert low threshold. Detailed alert information is accessible in the alert indication register.

The register contains two status bits per ADC, one corresponding to the high limit, and the other to the low limit. A logical OR of alert sig-

nals for all ADCs creates a common alert value. This value can be configured to drive out on the $\overline{\text{ALERT}}$ function of the SDOD/ $\overline{\text{ALERT}}$ pin. The SDOD/ $\overline{\text{ALERT}}$ pin is configured as $\overline{\text{ALERT}}$ by configuring the following bits in CONFIGURATION 1 and CONFIGURATION 2:

- ▶ Set the SDO bits to any value other than 0b10.
- ▶ Set the ALERT_EN bit to 1.
- ▶ Set a valid value in the alert high threshold register and the alert low threshold register.

The alert indication function is available in oversampling (rolling average, normal averaging, and in nonoversampling modes).

The alert function of the SDOD/ $\overline{\text{ALERT}}$ pin updates at the end of conversion. The alert indication status bits in the $\overline{\text{ALERT}}$ register are updated as well and must be read before the end of the next conversion.

Bits[7:0] in the alert indication register are cleared by reading the alert indication register contents. The alert function of the SDOD/ $\overline{\text{ALERT}}$ pin is cleared with a falling edge of $\overline{\text{CS}}$. Issuing a software reset also clears the alert status in the alert indication register.

See Figure 8 for the $\overline{\text{ALERT}}$ timing diagram.

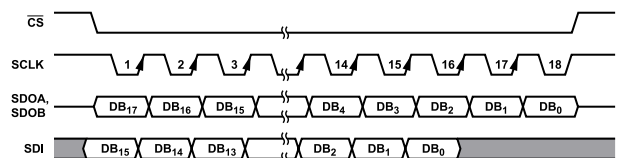

Figure 33. Resolution Boost

MODES OF OPERATION

POWER MODES

The AD7380-4 has two power modes that can be set in the Configuration 1 register: normal mode and shutdown mode. These modes of operation provide flexible power management options, allowing optimization of the power dissipation and throughput rate ratio for different application requirements.

Program the PMODE bit in the Configuration 1 register to configure the power modes in the AD7380-4. Set PMODE to Logic 0 for normal mode and Logic 1 for shutdown mode.

Normal Mode

Keep the AD7380-4 in normal mode to achieve the fastest throughput rate. All blocks within the AD7380-4 always remain fully powered and an ADC conversion can be initiated by a falling edge of \overline{CS} when required. When the AD7380-4 is not converting, it is in static mode and power consumption is automatically reduced. Additional current is required to perform a conversion. Therefore, power consumption of the AD7380-4 scales with throughput.

Shutdown Mode

When slower throughput rates and lower power consumption are required, use shutdown mode by either powering down the ADC between each conversion or by performing a series of conversions at a high throughput rate and then powering down the ADC for a relatively long duration between these burst conversions. When the AD7380-4 is in shutdown mode, all analog circuitry powers down. The serial interface remains active during shutdown mode to allow the AD7380-4 to exit shutdown mode.

To enter shutdown mode, write to the power mode configuration bit, PMODE, in the Configuration 1 register.

The AD7380-4 shuts down, and current consumption reduces. To exit shutdown mode and return to normal mode, set the PMODE bit in the CONFIGURATION 1 register to Logic 0. All register configuration settings remain unchanged entering or leaving shutdown mode. After exiting shutdown mode, allow sufficient time for the circuitry to turn on before starting a conversion.

EXTERNAL REFERENCE

The AD7380-4 core refers to the voltage in the REFIN pin during ADC conversion. The reference voltage of the AD7380-4 is driven through the REFIN pin. This pin can be supplied with a voltage

ranging from 2.5 V to 3.3 V. The external reference voltage must have enough current to drive the AD7380-4, which is a maximum of 1.2 mA. Connecting a 1 μ F capacitor to the REFIN pin is recommended. The recommended external voltage reference is the [ADR4525](#) for 2.5 V and the [ADR4533](#) for 3.3 V.

SOFTWARE RESET

The AD7380-4 has two reset modes: a soft reset and a hard reset. A reset is initiated by writing to the reset bits in the Configuration 2 register.

A soft reset maintains the contents of the configurable registers but refreshes the interface and the ADC blocks. Any internal state machines are reinitialized, and the oversampling block and FIFO are flushed. The alert indication register is cleared. The reference and LDO regulator remain powered.

A hard reset, in addition to the blocks reset by a soft reset, resets all user registers to the default status, and resets the internal oscillator block.

DIAGNOSTIC SELF TEST

The AD7380-4 runs a diagnostic self test after a POR or after a software hard reset to ensure that the correct configuration is loaded into the device.

The result of the self test is displayed in the SETUP_F bit in the alert indication register. If the SETUP_F bit is set to Logic 1, the diagnostic self test has failed. If the test fails, perform a software hard reset to reset the AD7380-4 registers to the default status.

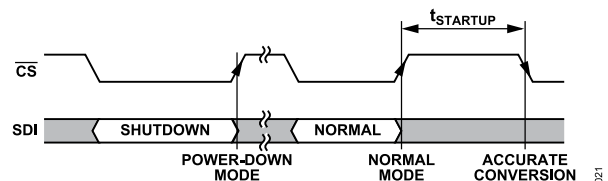

Figure 34. Shutdown Mode Operation

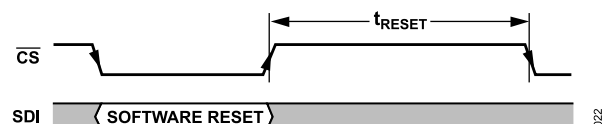

Figure 35. Software Reset Operation

INTERFACE

The interface to the AD7380-4 is via a serial interface. The interface consists of \overline{CS} , SCLK, SDOA, SDOB, SDOC, and SDOD, and SDI. When referencing a single function of a multifunction pin, only the portion of the pin name that is relevant to the specification is listed, such as SDOD. For full pin names of multifunction pins, refer to the [Pin Configuration and Function Descriptions](#) section.

The \overline{CS} signal frames a serial data transfer and initiates an ADC conversion process. The falling edge of \overline{CS} puts the track-and-hold into hold mode, at which point the analog input is sampled and the bus is taken out of three-state. The ADC conversion operation is driven internally by an on-board oscillator and is independent of the SCLK signal.

The SCLK signal synchronizes data in and out of the device via the SDOA, SDOB, SDOC, SDOD, and SDI signals. A minimum of 16 SCLK cycles are required for a write to or read from a register. The minimum numbers of SCLKs for a conversion read is dependent on the resolution of the device and the configuration settings (see [Table 13](#)).

The AD7380-4 has four serial output signals: SDOA, SDOB, SDOC, and SDOD. Programming the SDO bits in the CONFIGURATION 2 register configures 2-wire, 1-wire, or 4-wire mode. To achieve the highest throughput of the device, it is required to use either the 2-wire or 4-wire mode to read the conversion results. If a reduced throughput is required or oversampling is used, it is possible to use 1-wire mode, SDOA signal only, for reading conversion results.

Configuring cyclic redundancy check (CRC) operation for SPI reads, SPI writes and oversampling mode with resolution boost mode enabled can alter the operation of the interface. Refer to the [CRC](#) section to ensure correct operation.

READING CONVERSION RESULTS

The \overline{CS} signal initiates the conversion process. A high to low transition on the \overline{CS} signal initiates a simultaneous conversion of the four ADCs, ADC A, ADC B, ADC C, and ADC D. The AD7380-4 has a one cycle readback latency. Therefore, the conversion results are available on the next SPI access. Then, take the \overline{CS} signal low,

and the conversion result clocks out on the serial data output pins. The next conversion is also initiated at this point.

The conversion result is shifted out of the device as a 16-bit result for the AD7380-4. The MSB of the conversion result is shifted out on the \overline{CS} falling edge. The remaining data is shifted out of the device under the control of the serial clock (SCLK) input. The data is shifted out on the rising edge of SCLK, and the data bits are valid on both the falling edge and the rising edge. After the final SCLK falling edge, take \overline{CS} high again to return the serial data output pins to a high impedance state.

The number of SCLK cycles to propagate the conversion results on the serial data output pins is dependent on the serial mode of operation configured and if resolution boost mode is enabled (see [Figure 36](#) and [Table 13](#) for details). If CRC reading is enabled, additional SCLK pulses are required to propagate the CRC information. See the [CRC](#) section for more details.

Because the \overline{CS} signal initiates a conversion as well as framing the data any data access must be completed within a single frame.

Table 13. Number of SCLK Cycles (n) Required for Reading Conversion Results

Interface Configuration	Resolution Boost Mode	CRC Read	No. of SCLK Cycles
4-Wire	Disabled	Disabled	16
		Enabled	24
	Enabled	Disabled	18
		Enabled	26
2-Wire	Disabled	Disabled	32
		Enabled	40
	Enabled	Disabled	36
		Enabled	44
1-Wire	Disabled	Disabled	64
		Enabled	72
	Enabled	Disabled	72
		Enabled	80

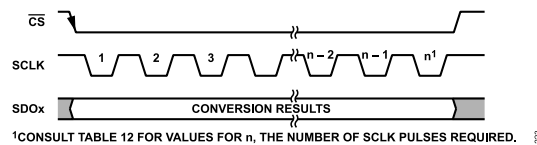

Figure 36. Reading Conversion Results

INTERFACE

Serial 4-Wire Mode

Configure 4-wire mode by setting the SDO bits to 0b10 in the CONFIGURATION 2 register. In 4-wire mode, the conversion results for ADC A is output on SDOA, ADC B on SDOB, ADC C on SDOC, and ADC D on SDOD.

Serial 2-Wire Mode

Configure 2-wire mode by setting the SDO bits to 0b00 in the CONFIGURATION 2 register. In 2-wire mode, the conversion results for ADC A and ADC C are output on SDOA. The conversion result for ADC B and ADC D are output on SDOB.

Serial 1-Wire Mode

In applications where slower throughput rates are allowed or normal averaging oversampling is used the serial interface can be config-

ured to operate in 1-wire mode. In 1-wire mode, the conversion results from ADC A, ADC B, ADC C, and ADC D are output on SDOA. Additional SCLK cycles are required to propagate all data. ADC A data is output first followed by the ADC B, ADC C, and ADC D conversion results.

LOW LATENCY READBACK

The interface on the AD7380-4 has a one-cycle latency as shown in Figure 38. For applications that operate at lower throughput rates the latency of reading the conversion result can be reduced. After the conversion time ($t_{CONVERT}$) elapses, a second \overline{CS} pulse after the initial \overline{CS} pulse that initiated the conversion can be used to read back the conversion result. This operation is shown in Figure 40.

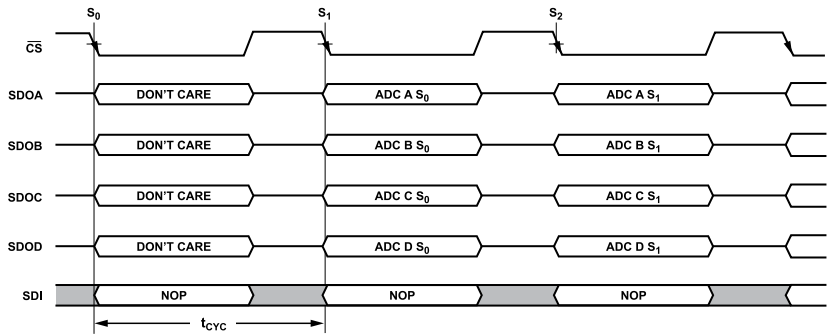

Figure 37. Read Conversion Results, 4-Wire Mode

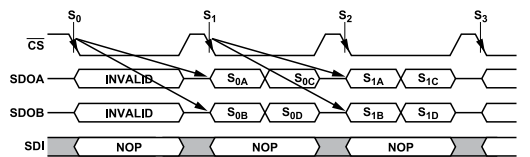

Figure 38. Read Conversion Results, 2-Wire Mode

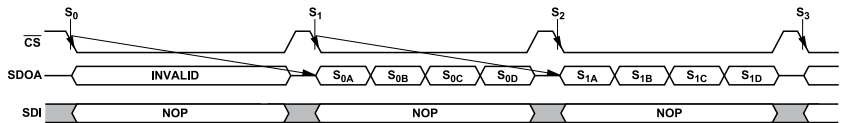

Figure 39. Reading Conversion Results, 1-Wire Mode

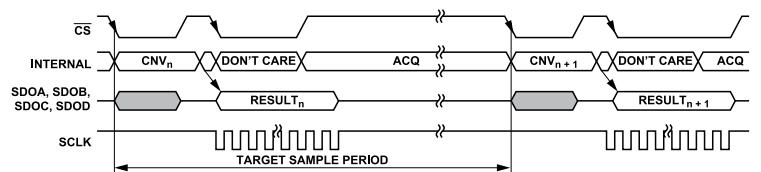

Figure 40. Low Throughput Low Latency

INTERFACE

READING FROM DEVICE REGISTERS

All registers in the device can be read over the serial interface. A register read is performed by issuing a register read command followed by an additional SPI command that can be either a valid command or no operation command (NOP). The format for a read command is shown in Table 16. Bit D15 must be set to 0 to select a read command. Bits[D14:D12] contain the register address. The subsequent 12 bits, Bits[D11:D0], are ignored.

WRITING TO DEVICE REGISTERS

All the read/write registers in the AD7380-4 can be written to over the serial interface. The length of a SPI write access is determined by the CRC write function. An SPI access is 16 bits if CRC write is disabled and 24 bits when CRC write is enabled. The format for a write command is shown in Table 16. Bit D15 must be set to 1 to select a write command. Bits[D14:D12] contain the register address. The subsequent 12 bits, Bits[D11:D0], contain the data to be written to the selected register.

CRC

The AD7380-4 has CRC checksum modes that can be used to improve interface robustness by detecting errors in data transmissions. The CRC feature is independently selectable for SPI interface reads and writes. For example, enable the CRC function for SPI writes to prevent unexpected changes to the device configuration but do not enable it on SPI reads to maintain a higher throughput rate. The CRC feature is controlled by programming of the CRC_W bit and CRC_R bit in the CONFIGURATION 1 register.

CRC Read

If enabled, a CRC consisting of an 8-bit word is appended to the conversion result or register reads. The CRC is calculated on the conversion result for ADC A, ADC B, ADC C, and ADC D, and is output on SDOA. A CRC is also calculated and appended to register read outputs.

The CRC read function can be used in 2-wire SPI mode, 1-wire SPI mode, 4-wire SPI mode, and resolution boost mode.

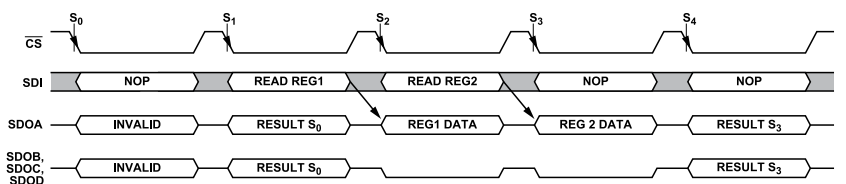

Figure 41. Register Read

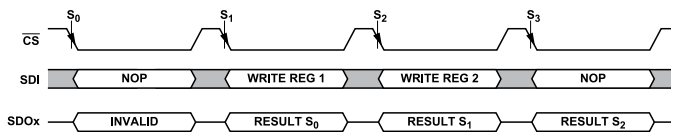

Figure 42. Register Write

INTERFACE

CRC Write

To enable the CRC write function, the CRC_W bit in the CONFIGURATION 1 register must be set to 1. To set the CRC_W bit to 1 to enable the CRC feature, a valid CRC must be appended to the request frame.

After the CRC feature is enabled, all register write requests are ignored unless they are accompanied by a valid CRC command. A valid CRC is required to both enable and disable the CRC write feature.

CRC Polynomial

For CRC checksum calculations the following polynomial is always used: $x^8 + x^2 + x + 1$.

To generate the checksum, the 16-bit data conversion result of the four channels are combined to produce a 64-bit data stream. The

eight MSBs of the 64-bit data are inverted and the data is appended by eight bits to create a number ending in eight Logic 0s. The polynomial is aligned such that its MSB is adjacent to the leftmost Logic 1 of the data. An exclusive OR (XOR) function is applied to the data to produce a new, shorter number. The polynomial is again aligned such that its MSB is adjacent to the leftmost Logic 1 of the new result, and the procedure is repeated. This process repeats until the original data is reduced to a value less than the polynomial, which is the 8-bit checksum.

For example, the AD7380-4 polynomial is 100000111. Let the original data of four channels be 0xAAAA, 0x5555, 0xAAAA, and 0x5555. The eight MSBs of the data are inverted. The data is then appended to include eight 0s on right. In the final XOR operation, the reduced data is less than the polynomial. Therefore, the remainder is the CRC for the assumed data.

Table 14. Example CRC Calculation for 4-Channel, 16-Bit Data

Data	1	0	1	0	1	0	1	0	1	0	1	0	1	0	0	1	0	1	0	1	0	1	0	1	0	1	0	1	X ¹	X ¹	X ¹	X ¹	X ¹	X ¹	X ¹	X ¹			
Process Data	0	1	0	1	0	1	0	1	1	0	1	0	1	0	0	1	0	1	0	1	0	1	0	1	0	1	0	1	0	0	0	0	0	0	0	0	0		
	1	0	0	0	0	0	1	1	1																														
		1	0	1	0	0	0	1	1	0																													
			1	0	0	0	0	0	1	1																													
				1	0	0	0	0	0	1	1	0																											
					1	0	0	0	0	0	1	1	1																										
						1	1	0	0	1	0	1	0	1																									
							1	0	0	0	0	0	1	1	1																								
								1	0	0	1	0	0	1	0	0																							
									1	0	0	0	0	0	1	1	1																						
										1	0	0	0	0	0	0	1	1	0	1																			
											1	0	0	0	0	0	1	1	1																				
												1	0	0	0	0	0	1	1	1	0																		
													1	0	0	0	0	0	1	1	1																		
														1	0	0	1	0	0	0	0	0																	
															1	0	0	0	0	0	1	1	1																
CRC																																							

¹ X means don't care.

INTERFACE

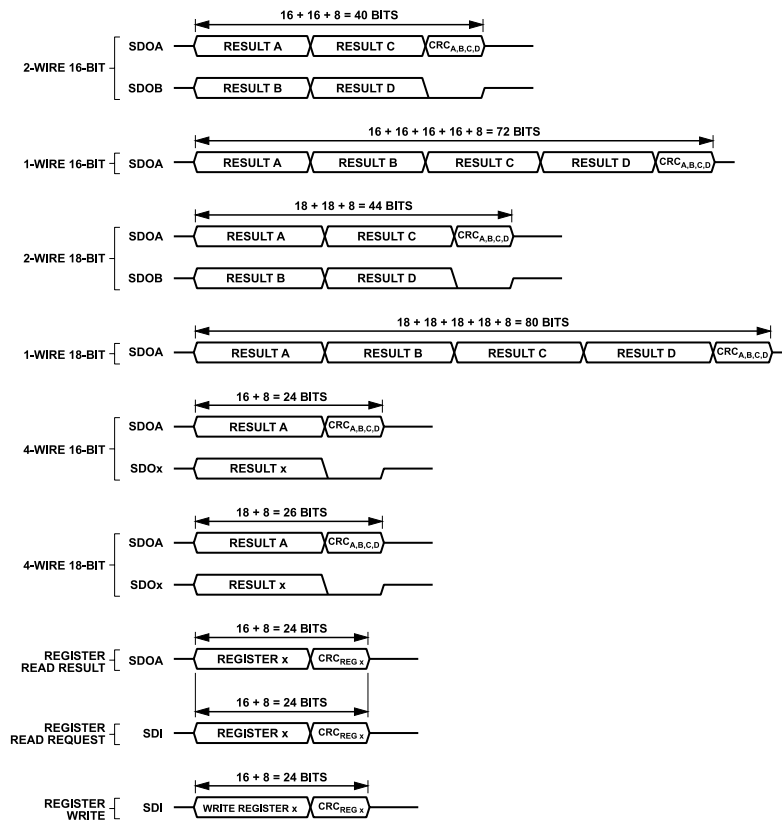

Figure 43. CRC Operation

REGISTERS

The AD7380-4 has user-programmable on-chip registers for configuring the device. Table 15 shows a complete overview of the registers available on the AD7380-4.

The registers are either read/write (R/W) or read only (R). Any read request to a write only register is ignored. Any write to a read only register is ignored. Writes to the NOP registers and the reserved register are ignored. Any read request to the NOP registers or reserved registers are considered a no operation and the data transmitted in the next SPI frame are the conversion results.

Table 15. Register Description

Reg	Name	Bits	Bit 15	Bit 14	Bit 13	Bit 12	Bit 11	Bit 10	Bit 9	Bit 8	Reset	R/W
			Bit 7	Bit 6	Bit 5	Bit 4	Bit 3	Bit 2	Bit 1	Bit 0		
0x1	Configuration 1	[15:8]	WR	ADDRESSING			RESERVED		OS_MODE	OSR, Bit 2	0x0000	R/W
		[7:0]	OSR, Bits[1:0]		CRC_W	CRC_R	ALERTEN	RES	RESERVED	PMODE		
0x2	Configuration 2	[15:8]	WR	ADDRESSING			RESERVED		SDO, Bits[1:0]		0x0000	R/W
		[7:0]	RESET, Bits[7:0]									
0x3	Alert	[15:8]	WR	ADDRESSING			RESERVED		CRCW_F	SETUP_F	0x0000	R
		[7:0]	AI_D_HIGH	AI_D_LOW	AI_C_HIGH	AI_C_LOW	AI_B_HIGH	AI_B_LOW	AI_A_HIGH	AI_A_LOW		
0x4	Alert low threshold	[15:8]	WR	ADDRESSING			ALERT_LOW, Bits[11:8]				0x0800	R
		[7:0]	ALERT_LOW, Bits[7:0]									
0x5	Alert high threshold	[15:8]	WR	ADDRESSING			ALERT_HIGH, Bits[11:8]				0x07FF	R/W
		[7:0]	ALERT_HIGH, Bits[7:0]									

ADDRESSING REGISTERS

A serial register transfer on the AD7380-4 consists of 16 SCLK cycles. The 4 MSBs written to the device are decoded to determine which register is addressed. The four MSBs consist of the register address (REGADDR), Bits[2:0], and the read/write bit (WR). The register address bits determine which on-chip register is selected. If the addressed register is a valid write register, the read/write bit determines whether the remaining 12 bits of data on the SDI input are loaded into the addressed register. If the WR bit is 1, the bits load into the register addressed by the register select bits. If the WR bit is 0, the command is seen as a read request. The addressed register data is available to be read during the next read operation.

Table 16. Addressing Register Format

MSB														LSB	
D15	D14	D13	D12	D11	D10	D9	D8	D7	D6	D5	D4	D3	D2	D1	D0
WR	REGADDR, Bits[2:0]			Data, Bits[11:0]											

Table 17. Bit Descriptions for Addressing Registers

Bit	Mnemonic	Description
D15	WR	When a 1 is written to this bit, Bits[11:0] of this register are written to the register specified by REGADDR if it is a valid address. Alternatively, when a 0 is written, the next data sent out on the SDOA pin is a read from the designated register if it is a valid address.
D14 to D12	REGADDR	When WR = 1, the contents of REGADDR determine the register for selection as outlined in Table 15. When WR = 0 and the REGADDR bits contain a valid register address, the contents on the requested register are output on the SDOA pin during the next interface access. When WR = 0 and the REGADDR bits contain 0x0, 0x6, or 0x7, the contents on the SDI line are ignored. The next interface access results in the conversion results being read back.
D11 to D0	Data	These bits are written into the corresponding register specified by the REGADDR bits when the WR bit = 1 and the REGADDR bits contain a valid address.

REGISTERS

CONFIGURATION 1 REGISTER

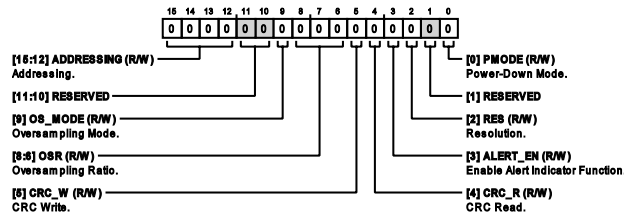

Table 18. Bit Descriptions for Configuration 1 Register

Bits	Bit Name	Description	Reset	Access
[15:12]	ADDRESSING	Addressing. Bits[15:12] define the address of the relevant register. See the Addressing Registers section for further details.	0x0	R/W
[11:10]	RESERVED	Reserved.	0x0	R
9	OS_MODE	Oversampling Mode. Sets the oversampling mode of the ADC. 0: normal averaging. 1: rolling average.	0x0	R/W
[8:6]	OSR	Oversampling Ratio. Sets the oversampling ratio for all the ADCs in the relevant mode. Normal averaging mode supports oversampling ratios of 2x, 4x, 8x, 16x, and 32x. Rolling average mode supports oversampling ratios of 2x, 4x, and 8x. 000: disabled. 001: 2x. 010: 4x. 011: 8x. 100: 16x. 101: 32x. 110: disabled. 111: disabled.	0x0	R/W
5	CRC_W	CRC Write. Controls the CRC functionality for the SDI interface. When setting this bit from a 0 to a 1, the command must be followed by a valid CRC to set this configuration bit. If a valid CRC is not received, the entire frame is ignored. If the bit is set to 1, it requires a CRC to clear it to 0. 0: no CRC function. 1: CRC function.	0x0	R/W
4	CRC_R	CRC Read. Controls the CRC functionality for the SDOx interface 0: no CRC function. 1: CRC function.	0x0	R/W
3	ALERT_EN	Enable Alert Indicator Function. This bit functions when the SDO bits = 01. Otherwise, the ALERT_EN bit is ignored. 0: SDO. 1: $\overline{\text{ALERT}}$.	0x0	R/W
2	RES	Resolution. Sets the size of the conversion result data. If OSR = 0, these bits are ignored and the resolution is set to default resolution. 0: normal resolution. 1: 2-bit higher resolution.	0x0	R/W
1	Reserved	Reserved.	0x0	R
0	PMODE	Power-Down Mode. Sets the power modes 0: normal mode. 1: shutdown mode.	0x0	R/W

REGISTERS

CONFIGURATION 2 REGISTER

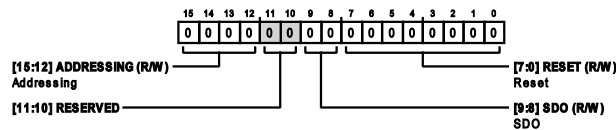

Table 19. Bit Descriptions for Configuration 2 Register

Bits	Bit Name	Description	Reset	Access
[15:12]	ADDRESSING	Addressing Bits. These bits define the address of the relevant register. See the Addressing Registers section for further details.	0x0	R/W
[11:10]	RESERVED	Reserved.	0x0	R
[9:8]	SDO	SDO. Conversion Results Serial Data Output 00: 2-wire output. Conversion data are output on both SDOA and SDOB. 01: 1-wire output. Conversion data are output on SDOA only. 10: 4-wire. Conversion data are output on SDOA, SDOB, SDOC, and SDOD/ALERT. 11: 1-wire. Conversion data are output on SDOA, only.	0x0	R/W
[7:0]	RESET	Reset. 0x3C: performs a soft reset. Refreshes some blocks, register contents remain unchanged. Clears alert indication register and flushes any oversampling stored variables or active state machine. 0xFF: performs a hard reset. Resets all possible blocks in the device. Registers contents are set to defaults. All other values are ignored.	0x0	R/W

ALERT INDICATION REGISTER

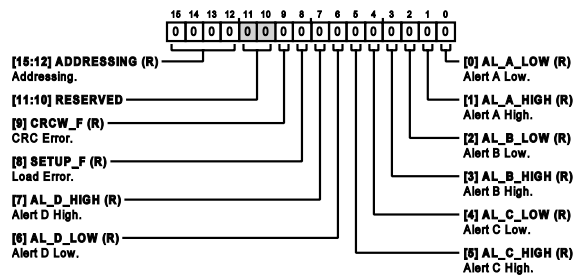

Table 20. Bit Descriptions for Alert Indication Register

Bits	Bit Name	Description	Reset	Access
[15:12]	ADDRESSING	Addressing. Bits[15:12] define the address of the relevant register. See the Addressing Registers section for further details.	0x0	R
[11:10]	RESERVED	Reserved.	0x0	R
9	CRCW_F	CRC Error. Indicates that a register write command failed due to a CRC error. This fault bit is sticky and remains set until the register is read 0: no CRC error. 1: CRC error.	0x0	R
8	SETUP_F	Load Error. The SETUP_F indicates that the device configuration data did not load correctly on startup. This bit does not clear on an alert indication register read. A hard reset via the Configuration 2 register is required to clear this bit and restart the device setup. 0: no setup error. 1: setup error.	0x0	R

REGISTERS

Table 20. Bit Descriptions for Alert Indication Register (Continued)

Bits	Bit Name	Description	Reset	Access
7	AL_D_HIGH	Alert D High. The alert indication high bit indicates if a conversion result for the respective input channel exceeds the value set in the alert high threshold register. This fault bit is sticky and remains set until the register is read. 1: alert indication. 0: no alert indication.	0x0	R
6	AL_D_LOW	Alert D Low. The alert indication low bit indicates if a conversion result for the respective input channel exceeds the value set in the alert low threshold register. This fault bit is sticky and remains set until the register is read. 0: no alert indication. 1: alert indication.	0x0	R
5	AL_C_HIGH	Alert C High. The alert indication high bit indicates if a conversion result for the respective input channel exceeds the value set in the alert high threshold register. This fault bit is sticky and remains set until the register is read. 1: alert indication. 0: no alert indication.	0x0	R
4	AL_C_LOW	Alert C Low. The alert indication low bit indicates if a conversion result for the respective input channel exceeds the value set in the alert low threshold register. This fault bit is sticky and remains set until the register is read. 1: alert indication. 0: no alert indication.	0x0	R
3	AL_B_HIGH	Alert B High. The alert indication high bit indicates if a conversion result for the respective input channel exceeds the value set in the alert high threshold register. This fault bit is sticky and remains set until the register is read. 1: alert indication. 0: no alert indication.	0x0	R
2	AL_B_LOW	Alert B Low. The alert indication low bit indicates if a conversion result for the respective input channel exceeds the value set in the alert low threshold register. This fault bit is sticky and remains set until the register is read. 1: alert indication. 0: no alert indication.	0x0	R
1	AL_A_HIGH	Alert A High. The alert indication high bit indicates if a conversion result for the respective input channel exceeds the value set in the alert high threshold register. This fault bit is sticky and remains set until the register is read. 0: no alert indication. 1: alert indication.	0x0	R
0	AL_A_LOW	Alert A Low. The alert indication low bit indicates if a conversion result for the respective input channel exceeds the value set in the alert low threshold register. This fault bit is sticky and remains set until the register is read. 1: alert indication. 0: no alert indication.	0x0	R

ALERT LOW THRESHOLD REGISTER

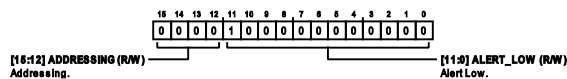

Table 21. Bit Descriptions for Alert Low Threshold Register

Bits	Bit Name	Descriptions	Reset	Access
[15:12]	ADDRESSING	Addressing. Bits[15:12] define the address of the relevant register. See the Addressing Registers section for further details.	0x0	R/W
[11:0]	ALERT_LOW	Alert Low. Bits[11:0] from ALERT_LOW move to the MSBs of the internal alert low register, D[15:4]. The remaining bits, D[3:0] of the internal register are fixed at 0x0. Sets an alert when the converter result is below the value in the alert low threshold register, and the alert is disabled when it is above the value in the alert low threshold register.	0x800	R/W

REGISTERS

ALERT HIGH THRESHOLD REGISTER

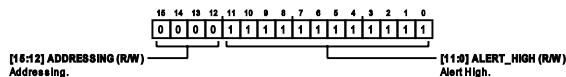

Table 22. Bit Descriptions for Alert High Threshold Register

Bits	Bit Name	Description	Reset	Access
[15:12]	ADDRESSING	Addressing. Bits [15:12] define the address of the relevant register. See the Addressing Registers Section for further details.	0x0	R/W
[11:0]	ALERT_HIGH	Alert High. Bits D[11:0] from ALERT_HIGH move to the MSBs of the internal alert high register, D[15:4]. The remaining bits, D[3:0] of the internal are fixed at 0xF. Sets an alert when the converter result is above the value in the alert high threshold register, and the alert is disabled when it is below the value in the alert high threshold register.	0xFFF	R/W

OUTLINE DIMENSIONS

Package Drawing (Option)	Package Type	Package Description
CP-24-25	LFCSP	24-Lead Lead Frame Chip Scale Package

For the latest package outline information and land patterns (footprints), go to [Package Index](#).

Updated: April 18, 2024

ORDERING GUIDE

Model ¹	Temperature Range	Package Description	Packing Quantity	Package Option
AD7380-4BCPZ	-40°C to +125°C	24-Lead LFCSP (4mm x 4mm x 0.55mm)		CP-24-25
AD7380-4BCPZ-RL	-40°C to +125°C	24-Lead LFCSP (4mm x 4mm x 0.55mm)	Reel, 5000	CP-24-25
AD7380-4BCPZ-RL7	-40°C to +125°C	24-Lead LFCSP (4mm x 4mm x 0.55mm)	Reel, 1000	CP-24-25

¹ Z = RoHS Compliant Part.

RESOLUTION OPTIONS

Model ¹	Resolution
AD7380-4BCPZ	16-Bit
AD7380-4BCPZ-RL	16-Bit
AD7380-4BCPZ-RL7	16-Bit

¹ Z = RoHS Compliant Part.

EVALUATION BOARDS

Model ^{1, 2}	Description
EVAL-AD7380-4FMCZ	AD7380-4 Evaluation Board
EVAL-SDP-CH1Z	Evaluation Board Controller

¹ Z = RoHS Compliant Part.

² The EVAL-AD7380-4FMCZ is compatible with the EVAL-SDP-CH1Z high speed controller board.

Looking for pricing, stock, or lifecycle information?

Click below to explore more details on WIN SOURCE:

 [View AD7380-4BCPZ on WIN SOURCE](#)

 [Analog Devices Inc. Information](#)

Optimize Your Supply Chain with WIN SOURCE Solutions

-  Global Sourcing Solution
-  Obsolete Management
-  Cost Control Management
-  Shortage Management
-  Alternative Solution
-  Excess Inventory Management