



**THE DATASHEET OF
LTC2415IGN#PBF**



FEATURES

- **2× Speed Up Version of the LTC2410/LTC2413: 15Hz Output Rate, 50Hz or 60Hz Notch—LTC2415; 13.75Hz Output Rate, Simultaneous 50Hz/60Hz Notch—LTC2415-1**
- **Differential Input and Differential Reference with GND to V_{CC} Common Mode Range**
- **2ppm INL, No Missing Codes**
- **2.5ppm Gain Error**
- **0.23ppm Noise**
- **Single Conversion Settling Time for Multiplexed Applications**
- **Internal Oscillator—No External Components Required**
- **24-Bit ADC in Narrow SSOP-16 Package (SO-8 Footprint)**
- **Single Supply 2.7V to 5.5V Operation**
- **Low Supply Current (200 μ A) and Auto Shutdown**

APPLICATIONS

- Direct Sensor Digitizer
- Weight Scales
- Direct Temperature Measurement
- Gas Analyzers
- Strain Gage Transducers
- Instrumentation
- Data Acquisition
- Industrial Process Control
- 6-Digit DVMs

DESCRIPTION

The **LTC[®]2415/2415-1** are micropower 24-bit differential $\Delta\Sigma$ analog to digital converters with integrated oscillator, 2ppm INL, 0.23ppm RMS noise and a 2.7V to 5.5V supply range. They use delta-sigma technology and provide single cycle settling time for multiplexed applications. Through a single pin, the LTC2415 can be configured for better than 110dB input differential mode rejection at 50Hz or 60Hz \pm 2%, or it can be driven by an external oscillator for a user defined rejection frequency. The LTC2415-1 can be configured for better than 87dB input differential mode rejection over the range of 49Hz to 61.2Hz (50Hz and 60Hz \pm 2% simultaneously). The internal oscillator requires no external frequency setting components.

The converters accept any external differential reference voltage from 0.1V to V_{CC} for flexible ratiometric and remote sensing measurement configurations. The full-scale differential input range is from $-0.5V_{REF}$ to $0.5V_{REF}$. The reference common mode voltage, V_{REFCM} , and the input common mode voltage, V_{INCM} , may be independently set anywhere within the GND to V_{CC} range of the LTC2415/LTC2415-1. The DC common mode input rejection is better than 140dB.

The LTC2415/LTC2415-1 communicate through a flexible 3-wire digital interface which is compatible with SPI and MICROWIRE protocols.

$\Delta\Sigma$, LT, LTC, LTM, Linear Technology and the Linear logo are registered trademarks and C-Load and No Latency $\Delta\Sigma$ are trademarks of Linear Technology Corporation. All other trademarks are the property of their respective owners.

TYPICAL APPLICATION

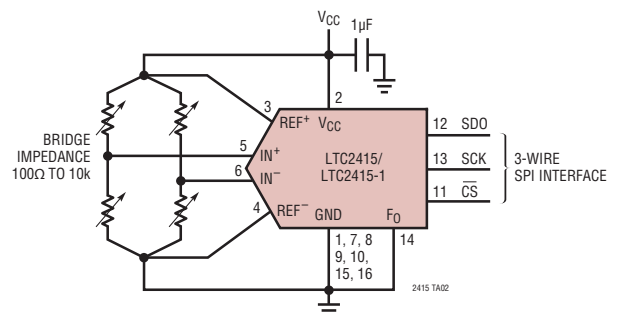
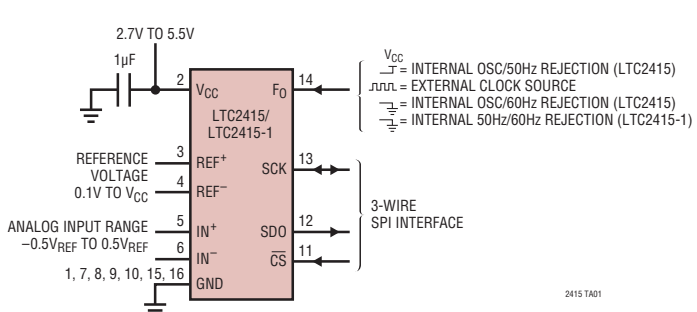

2415fa

LTC2415/LTC2415-1

ABSOLUTE MAXIMUM RATINGS

(Note 1)

Supply Voltage (V_{CC}) to GND	-0.3V to 7V
Analog Input Pins Voltage to GND	-0.3V to ($V_{CC} + 0.3V$)
Reference Input Pins Voltage to GND	-0.3V to ($V_{CC} + 0.3V$)
Digital Input Voltage to GND	-0.3V to ($V_{CC} + 0.3V$)
Digital Output Voltage to GND	-0.3V to ($V_{CC} + 0.3V$)
Operating Temperature Range	
LTC2415C/LTC2415-1C	0°C to 70°C
LTC2415I/LTC2415-1I	-40°C to 85°C
Storage Temperature Range	-65°C to 150°C
Lead Temperature (Soldering, 10 sec).....	300°C

PIN CONFIGURATION

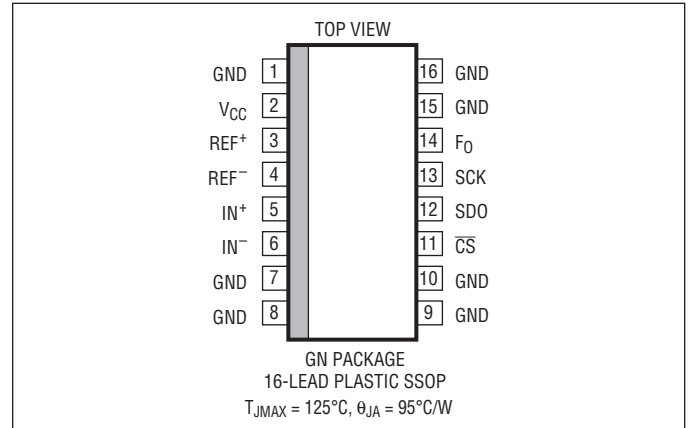

ORDER INFORMATION

LEAD FREE FINISH	TAPE AND REEL	PART MARKING	PACKAGE DESCRIPTION	TEMPERATURE RANGE
LTC2415CGN#PBF	LTC2415CGN#TRPBF	2415	16-Lead Plastic SSOP	0°C to 70°C
LTC2415IGN#PBF	LTC2415IGN#TRPBF	2415I	16-Lead Plastic SSOP	-40°C to 85°C
LTC2415-1CGN#PBF	LTC2415-1CGN#TRPBF	24151	16-Lead Plastic SSOP	0°C to 70°C
LTC2415-1IGN#PBF	LTC2415-1IGN#TRPBF	24151I	16-Lead Plastic SSOP	-40°C to 85°C

Consult LTC Marketing for parts specified with wider operating temperature ranges.

Consult LTC Marketing for information on nonstandard lead based finish parts.

For more information on lead free part marking, go to: <http://www.linear.com/leadfree/>

For more information on tape and reel specifications, go to: <http://www.linear.com/tapeandreeel/>

ELECTRICAL CHARACTERISTICS

The ● denotes the specifications which apply over the full operating temperature range, otherwise specifications are at $T_A = 25^\circ\text{C}$. (Notes 3,4)

PARAMETER	CONDITIONS	MIN	TYP	MAX	UNITS
Resolution (No Missing Codes)	$0.1V \leq V_{REF} \leq V_{CC}$, $-0.5 \cdot V_{REF} \leq V_{IN} \leq 0.5 \cdot V_{REF}$, (Note 5)	●	24		Bits
Integral Nonlinearity	$5V \leq V_{CC} \leq 5.5V$, $REF^+ = 2.5V$, $REF^- = GND$, $V_{INCM} = 1.25V$, (Note 6)	●	1		ppm of V_{REF}
	$5V \leq V_{CC} \leq 5.5V$, $REF^+ = 5V$, $REF^- = GND$, $V_{INCM} = 2.5V$, (Note 6)	●	2	14	ppm of V_{REF}
	$REF^+ = 2.5V$, $REF^- = GND$, $V_{INCM} = 1.25V$, (Note 6)	●	5		ppm of V_{REF}
Offset Error	$2.5V \leq REF^+ \leq V_{CC}$, $REF^- = GND$, $GND \leq IN^+ = IN^- \leq V_{CC}$, (Note 14)	●	0.5	2	mV
Offset Error Drift	$2.5V \leq REF^+ \leq V_{CC}$, $REF^- = GND$, $GND \leq IN^+ = IN^- \leq V_{CC}$		20		nV/°C
Positive Gain Error	$2.5V \leq REF^+ \leq V_{CC}$, $REF^- = GND$, $IN^+ = 0.75REF^+$, $IN^- = 0.25 \cdot REF^+$	●	2.5	12	ppm of V_{REF}
Positive Gain Error Drift	$2.5V \leq REF^+ \leq V_{CC}$, $REF^- = GND$, $IN^+ = 0.75REF^+$, $IN^- = 0.25 \cdot REF^+$		0.03		ppm of $V_{REF}/^\circ\text{C}$
Negative Gain Error	$2.5V \leq REF^+ \leq V_{CC}$, $REF^- = GND$, $IN^+ = 0.25 \cdot REF^+$, $IN^- = 0.75 \cdot REF^+$	●	2.5	12	ppm of V_{REF}

2415fa

ELECTRICAL CHARACTERISTICS

The ● denotes the specifications which apply over the full operating temperature range, otherwise specifications are at $T_A = 25^\circ\text{C}$. (Notes 3,4)

PARAMETER	CONDITIONS	MIN	TYP	MAX	UNITS
Negative Gain Error Drift	$2.5\text{V} \leq \text{REF}^+ \leq V_{\text{CC}}$, $\text{REF}^- = \text{GND}$, $\text{IN}^+ = 0.25 \cdot \text{REF}^+$, $\text{IN}^- = 0.75 \cdot \text{REF}^+$		0.03		ppm of $V_{\text{REF}}/^\circ\text{C}$
Output Noise	$5\text{V} \leq V_{\text{CC}} \leq 5.5\text{V}$, $\text{REF}^+ = 5\text{V}$, $\text{REF}^- = \text{GND}$, $\text{GND} \leq \text{IN}^- = \text{IN}^+ \leq V_{\text{CC}}$, (Note 13)		1.1		μV_{RMS}

CONVERTER CHARACTERISTICS

The ● denotes the specifications which apply over the full operating temperature range, otherwise specifications are at $T_A = 25^\circ\text{C}$. (Notes 3,4)

PARAMETER	CONDITIONS	MIN	TYP	MAX	UNITS
Input Common Mode Rejection DC	$2.5\text{V} \leq \text{REF}^+ \leq V_{\text{CC}}$, $\text{REF}^- = \text{GND}$, $\text{GND} \leq \text{IN}^- = \text{IN}^+ \leq V_{\text{CC}}$ ●	130	140		dB
Input Common Mode Rejection 60Hz $\pm 2\%$ (LTC2415)	$2.5\text{V} \leq \text{REF}^+ \leq V_{\text{CC}}$, $\text{REF}^- = \text{GND}$, $\text{GND} \leq \text{IN}^- = \text{IN}^+ \leq V_{\text{CC}}$, (Note 7) ●	140			dB
Input Common Mode Rejection 50Hz $\pm 2\%$ (LTC2415)	$2.5\text{V} \leq \text{REF}^+ \leq V_{\text{CC}}$, $\text{REF}^- = \text{GND}$, $\text{GND} \leq \text{IN}^- = \text{IN}^+ \leq V_{\text{CC}}$, (Note 8) ●	140			dB
Input Normal Mode Rejection 60Hz $\pm 2\%$ (LTC2415)	(Note 7) ●	110	140		dB
Input Normal Mode Rejection 50Hz $\pm 2\%$ (LTC2415)	(Note 8) ●	110	140		dB
Input Common Mode Rejection 49Hz to 61.2Hz (LTC2415-1)	$2.5\text{V} \leq \text{REF}^+ \leq V_{\text{CC}}$, $\text{REF}^- = \text{GND}$, ●	140			dB
Input Normal Mode Rejection 49Hz to 61.2Hz (LTC2415-1)	$F_0 = \text{GND}$ ●	87			dB
Input Normal Mode Rejection External Clock $f_{\text{EOSC}}/2560 \pm 14\%$ (LTC2415-1)	External Oscillator ●	87			dB
Input Normal Mode Rejection External Clock $f_{\text{EOSC}}/2560 \pm 4\%$ (LTC2415-1)	External Oscillator ●	110	140		dB
Reference Common Mode Rejection DC	$2.5\text{V} \leq \text{REF}^+ \leq V_{\text{CC}}$, $\text{GND} \leq \text{REF}^- \leq 2.5\text{V}$, $V_{\text{REF}} = 2.5\text{V}$, $\text{IN}^- = \text{IN}^+ = \text{GND}$ ●	130	140		dB
Power Supply Rejection, DC	$\text{REF}^+ = V_{\text{CC}}$, $\text{REF}^- = \text{GND}$, $\text{IN}^- = \text{IN}^+ = \text{GND}$		100		dB
Power Supply Rejection, 60Hz $\pm 2\%$	$\text{REF}^+ = 2.5\text{V}$, $\text{REF}^- = \text{GND}$, $\text{IN}^- = \text{IN}^+ = \text{GND}$, (Note 7)		120		dB
Power Supply Rejection, 50Hz $\pm 2\%$	$\text{REF}^+ = 2.5\text{V}$, $\text{REF}^- = \text{GND}$, $\text{IN}^- = \text{IN}^+ = \text{GND}$, (Note 8)		120		dB

ANALOG INPUT AND REFERENCE

The ● denotes the specifications which apply over the full operating temperature range, otherwise specifications are at $T_A = 25^\circ\text{C}$. (Notes 3,4)

SYMBOL	PARAMETER	CONDITIONS	MIN	TYP	MAX	UNITS
IN^+	Absolute/Common Mode IN^+ Voltage	●	$\text{GND} - 0.3\text{V}$		$V_{\text{CC}} + 0.3\text{V}$	V
IN^-	Absolute/Common Mode IN^- Voltage	●	$\text{GND} - 0.3\text{V}$		$V_{\text{CC}} + 0.3\text{V}$	V
V_{IN}	Input Differential Voltage Range ($\text{IN}^+ - \text{IN}^-$)	●	$-V_{\text{REF}}/2$		$V_{\text{REF}}/2$	V
REF^+	Absolute/Common Mode REF^+ Voltage	●	0.1		V_{CC}	V
REF^-	Absolute/Common Mode REF^- Voltage	●	GND		$V_{\text{CC}} - 0.1\text{V}$	V
V_{REF}	Reference Differential Voltage Range ($\text{REF}^+ - \text{REF}^-$)	●	0.1		V_{CC}	V

2415fa

LTC2415/LTC2415-1

ANALOG INPUT AND REFERENCE

The ● denotes the specifications which apply over the full operating temperature range, otherwise specifications are at $T_A = 25^\circ\text{C}$. (Notes 3,4)

SYMBOL	PARAMETER	CONDITIONS	MIN	TYP	MAX	UNITS
C_S (IN ⁺)	IN ⁺ Sampling Capacitance			18		pF
C_S (IN ⁻)	IN ⁻ Sampling Capacitance			18		pF
C_S (REF ⁺)	REF ⁺ Sampling Capacitance			18		pF
C_S (REF ⁻)	REF ⁻ Sampling Capacitance			18		pF
I_{DC_LEAK} (IN ⁺)	IN ⁺ DC Leakage Current	$\overline{CS} = V_{CC}$, IN ⁺ = GND	● -10	1	10	nA
I_{DC_LEAK} (IN ⁻)	IN ⁻ DC Leakage Current	$\overline{CS} = V_{CC}$, IN ⁻ = GND	● -10	1	10	nA
I_{DC_LEAK} (REF ⁺)	REF ⁺ DC Leakage Current	$\overline{CS} = V_{CC}$, REF ⁺ = 5V	● -10	1	10	nA
I_{DC_LEAK} (REF ⁻)	REF ⁻ DC Leakage Current	$\overline{CS} = V_{CC}$, REF ⁻ = GND	● -10	1	10	nA

DIGITAL INPUTS AND DIGITAL OUTPUTS

The ● denotes the specifications which apply over the full operating temperature range, otherwise specifications are at $T_A = 25^\circ\text{C}$. (Notes 3)

SYMBOL	PARAMETER	CONDITIONS	MIN	TYP	MAX	UNITS
V_{IH}	High Level Input Voltage CS, F ₀	$2.7V \leq V_{CC} \leq 5.5V$ $2.7V \leq V_{CC} \leq 3.3V$	● 2.5 2.0			V V
V_{IL}	Low Level Input Voltage CS, F ₀	$4.5V \leq V_{CC} \leq 5.5V$ $2.7V \leq V_{CC} \leq 5.5V$	●		0.8 0.6	V V
V_{IH}	High Level Input Voltage SCK	$2.7V \leq V_{CC} \leq 5.5V$ (Note 9) $2.7V \leq V_{CC} \leq 3.3V$ (Note 9)	● 2.5 2.0			V V
V_{IL}	Low Level Input Voltage SCK	$4.5V \leq V_{CC} \leq 5.5V$ (Note 9) $2.7V \leq V_{CC} \leq 5.5V$ (Note 9)	●		0.8 0.6	V V
I_{IN}	Digital Input Current CS, F ₀	$0V \leq V_{IN} \leq V_{CC}$	● -10		10	μA
I_{IN}	Digital Input Current SCK	$0V \leq V_{IN} \leq V_{CC}$ (Note 9)	● -10		10	μA
C_{IN}	Digital Input Capacitance CS, F ₀			10		pF
C_{IN}	Digital Input Capacitance SCK	(Note 9)		10		pF
V_{OH}	High Level Output Voltage SDO	$I_O = -800\mu A$	● $V_{CC} - 0.5$			V
V_{OL}	Low Level Output Voltage SDO	$I_O = 1.6mA$	●		0.4	V
V_{OH}	High Level Output Voltage SCK	$I_O = -800\mu A$ (Note 10)	● $V_{CC} - 0.5$			V
V_{OL}	Low Level Output Voltage SCK	$I_O = 1.6mA$ (Note 10)	●		0.4	V
I_{OZ}	Hi-Z Output Leakage SDO		● -10		10	μA

POWER REQUIREMENTS

The ● denotes the specifications which apply over the full operating temperature range, otherwise specifications are at $T_A = 25^\circ\text{C}$. (Note 3)

SYMBOL	PARAMETER	CONDITIONS	MIN	TYP	MAX	UNITS
V_{CC}	Supply Voltage		● 2.7		5.5	V
I_{CC}	Supply Current Conversion Mode	$\overline{CS} = 0V$ (Note 12)	●	200	300	μA
	Sleep Mode	$\overline{CS} = V_{CC}$ (Note 12)	●	20	30	μA

2415fa

TIMING CHARACTERISTICS

The ● denotes the specifications which apply over the full operating temperature range, otherwise specifications are at $T_A = 25^\circ\text{C}$. (Notes 3,4)

SYMBOL	PARAMETER	CONDITIONS	MIN	TYP	MAX	UNITS
f_{EOSC}	External Oscillator Frequency Range		● 2.56		500	kHz
t_{HEO}	External Oscillator High Period		● 0.25		390	μs
t_{LEO}	External Oscillator Low Period		● 0.25		390	μs
t_{CONV}	Conversion Time (LTC2415)	$F_0 = 0\text{V}$	● 65.43	66.77	68.1	ms
		$F_0 = V_{\text{CC}}$	● 78.52	80.12	81.72	ms
		External Oscillator (Note 11)		10278/ f_{EOSC} (in kHz)		ms
	Conversion Time (LTC2415-1)	$F_0 = 0\text{V}$ External Oscillator (Note 11)	● 71.3	72.8	74.3	ms
				10278/ f_{EOSC} (in kHz)		ms
f_{ISCK}	Internal SCK Frequency	Internal Oscillator (Note 10), LTC2415		19.2		kHz
		Internal Oscillator (Note 10), LTC2415-1		17.5		kHz
		External Oscillator (Notes 10, 11)		$f_{\text{EOSC}}/8$		kHz
D_{ISCK}	Internal SCK Duty Cycle	(Note 10)	● 45		55	%
f_{ESCK}	External SCK Frequency Range	(Note 9)	●		2000	kHz
t_{LESCK}	External SCK Low Period	(Note 9)	● 250			ns
t_{HESCK}	External SCK High Period	(Note 9)	● 250			ns
$t_{\text{DOUT_ISCK}}$	Internal SCK 32-Bit Data Output Time	Internal Oscillator (Notes 10, 12), LTC2415	● 1.64	1.67	1.70	ms
		Internal Oscillator (Notes 10, 12), LTC2415-1	● 1.80	1.83	1.86	ms
		External Oscillator (Notes 10, 11)		256/ f_{EOSC} (in kHz)		ms
$t_{\text{DOUT_ESCK}}$	External SCK 32-Bit Data Output Time	(Note 9)	●	32/ f_{ESCK} (in kHz)		ms
t_1	$\overline{\text{CS}} \downarrow$ to SDO Low Z		● 0		200	ns
t_2	$\overline{\text{CS}} \uparrow$ to SDO High Z		● 0		200	ns
t_3	$\overline{\text{CS}} \downarrow$ to SCK \downarrow	(Note 10)	● 0		200	ns
t_4	$\overline{\text{CS}} \downarrow$ to SCK \uparrow	(Note 9)	● 50			ns
t_{KQMAX}	SCK \downarrow to SDO Valid		●		220	ns
t_{KQMIN}	SDO Hold After SCK \downarrow	(Note 5)	● 15			ns
t_5	SCK Set-Up Before $\overline{\text{CS}} \downarrow$		● 50			ns
t_6	SCK Hold After $\overline{\text{CS}} \downarrow$		●		50	ns

Note 1: Stresses beyond those listed under Absolute Maximum Ratings may cause permanent damage to the device. Exposure to any Absolute Maximum Rating condition for extended periods may affect device reliability and lifetime.

Note 2: All voltage values are with respect to GND.

Note 3: $V_{\text{CC}} = 2.7$ to 5.5V unless otherwise specified.

$V_{\text{REF}} = \text{REF}^+ - \text{REF}^-$, $V_{\text{REFCM}} = (\text{REF}^+ + \text{REF}^-)/2$;

$V_{\text{IN}} = \text{IN}^+ - \text{IN}^-$, $V_{\text{INCM}} = (\text{IN}^+ + \text{IN}^-)/2$.

Note 4: F_0 pin tied to GND or to V_{CC} or to external conversion clock source with $f_{\text{EOSC}} = 153600\text{Hz}$ unless otherwise specified.

Note 5: Guaranteed by design, not subject to test.

Note 6: Integral nonlinearity is defined as the deviation of a code from a straight line passing through the actual endpoints of the transfer curve. The deviation is measured from the center of the quantization band.

Note 7: $F_0 = 0\text{V}$ (internal oscillator) or $f_{\text{EOSC}} = 153600\text{Hz} \pm 2\%$ (external oscillator).

Note 8: $F_0 = V_{\text{CC}}$ (internal oscillator) or $f_{\text{EOSC}} = 128000\text{Hz} \pm 2\%$ (external oscillator).

Note 9: The converter is in external SCK mode of operation such that the SCK pin is used as digital input. The frequency of the clock signal driving SCK during the data output is f_{ESCK} and is expressed in kHz.

Note 10: The converter is in internal SCK mode of operation such that the SCK pin is used as digital output. In this mode of operation the SCK pin has a total equivalent load capacitance $C_{\text{LOAD}} = 20\text{pF}$.

Note 11: The external oscillator is connected to the F_0 pin. The external oscillator frequency, f_{EOSC} , is expressed in kHz.

Note 12: The converter uses the internal oscillator.

$F_0 = 0\text{V}$ or $F_0 = V_{\text{CC}}$.

Note 13: The output noise includes the contribution of the internal calibration operations.

Note 14: Refer to Offset Accuracy and Drift in the Applications Information section.

TYPICAL PERFORMANCE CHARACTERISTICS

Total Unadjusted Error Over Temperature ($V_{CC} = 5V$, $V_{REF} = 5V$)

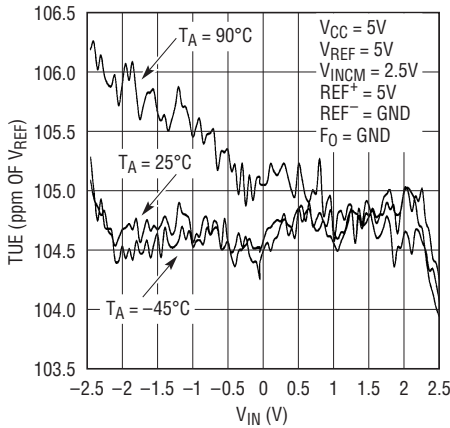

2415 G01

Total Unadjusted Error Over Temperature ($V_{CC} = 5V$, $V_{REF} = 2.5V$)

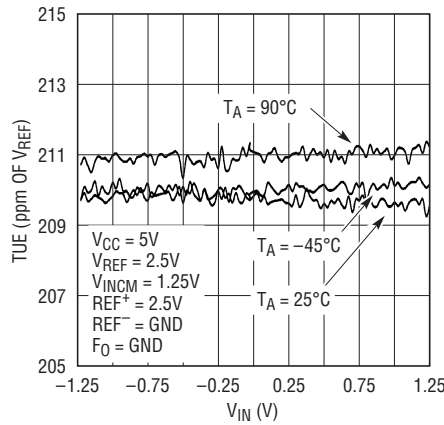

2415 G02

Total Unadjusted Error Over Temperature ($V_{CC} = 2.7V$, $V_{REF} = 2.5V$)

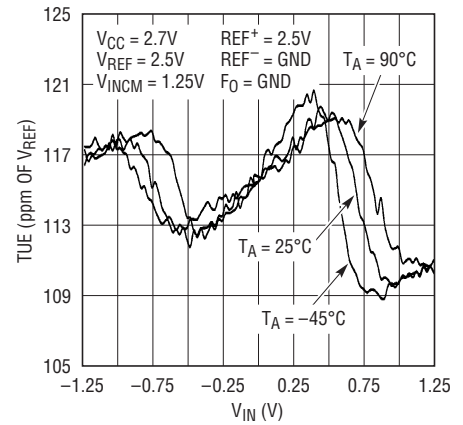

2415 G03

Integral Nonlinearity Over Temperature ($V_{CC} = 5V$, $V_{REF} = 5V$)

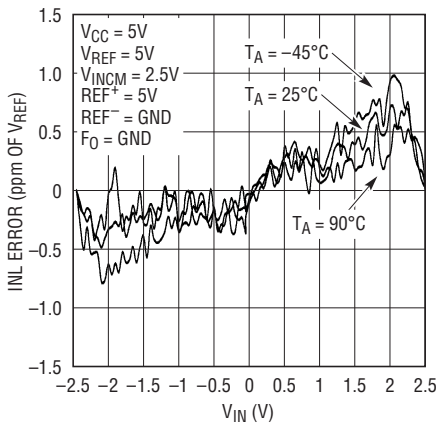

2415 G04

Integral Nonlinearity Over Temperature ($V_{CC} = 5V$, $V_{REF} = 2.5V$)

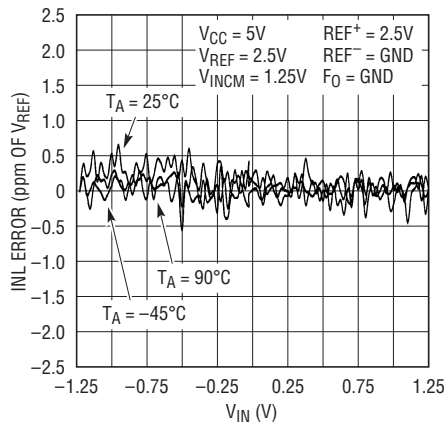

2415 G05

Integral Nonlinearity Over Temperature ($V_{CC} = 2.7V$, $V_{REF} = 2.5V$)

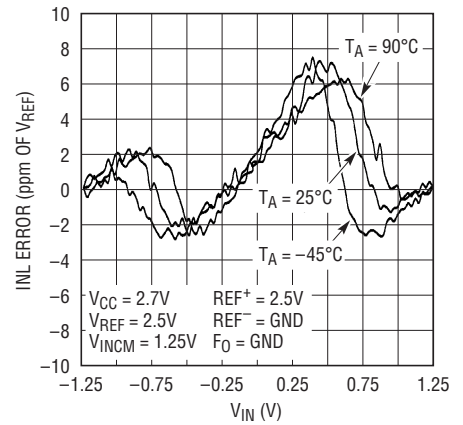

2415 G06

Noise Histogram (Output Rate = 15Hz, $V_{CC} = 5V$, $V_{REF} = 5V$)

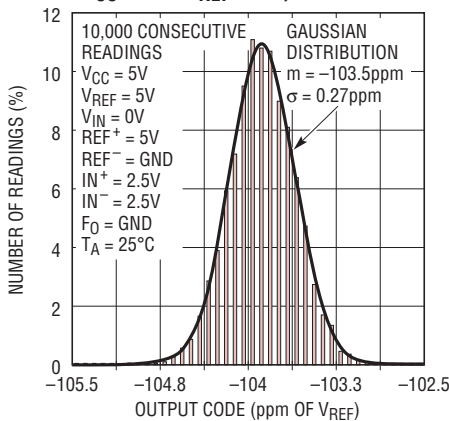

2415 G07

Noise Histogram (Output Rate = 45Hz, $V_{CC} = 5V$, $V_{REF} = 5V$)

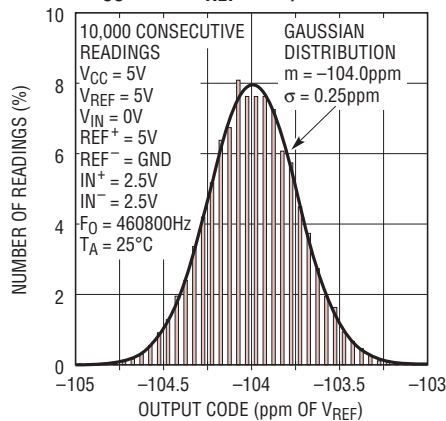

2415 G08

Noise Histogram (Output Rate = 15Hz, $V_{CC} = 5V$, $V_{REF} = 2.5V$)

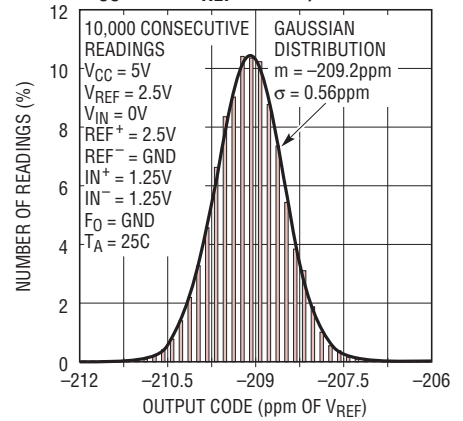

2415 G10

2415fa

TYPICAL PERFORMANCE CHARACTERISTICS

**Noise Histogram
(Output Rate = 45Hz,
V_{CC} = 5V, V_{REF} = 2.5V)**

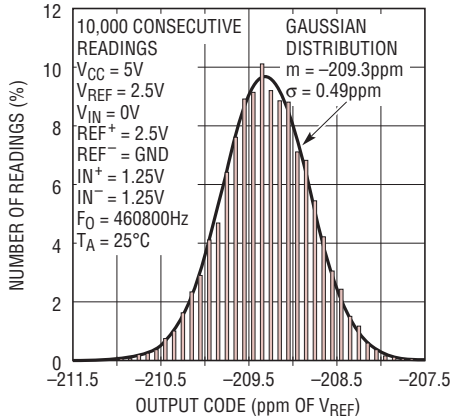

2415 G11

**Noise Histogram
(Output Rate = 15Hz,
V_{CC} = 2.7V, V_{REF} = 2.5V)**

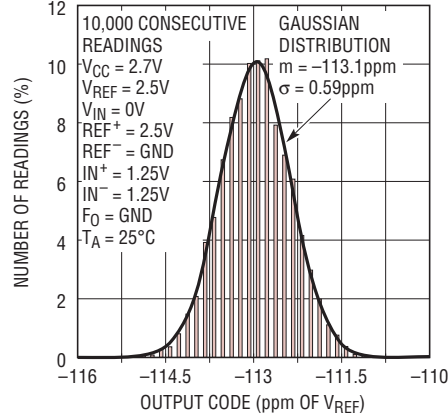

2415 G13

**Noise Histogram
(Output Rate = 45Hz,
V_{CC} = 2.7V, V_{REF} = 2.5V)**

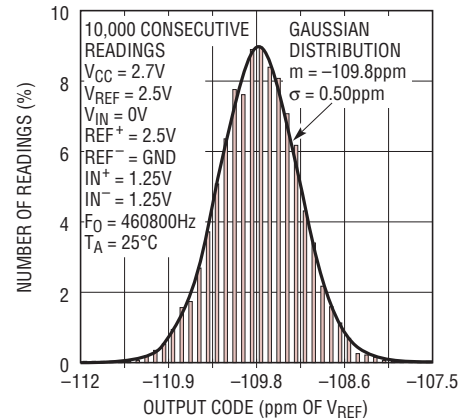

2415 G14

**Long-Term Histogram
(60Hrs)**

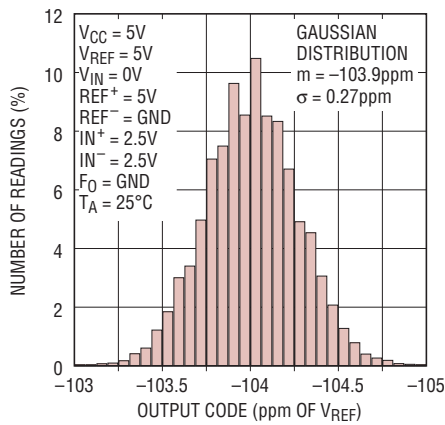

2415 G16

**Consecutive ADC Readings vs
Time**

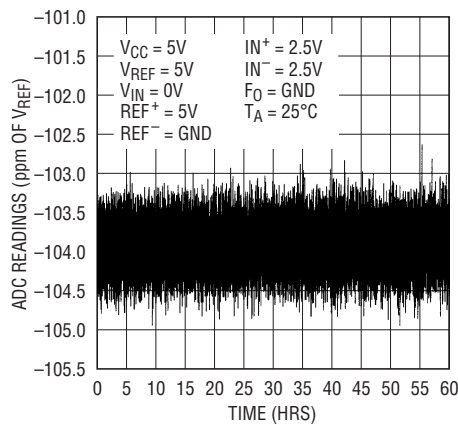

2415 G17

**RMS Noise vs Input Differential
Voltage**

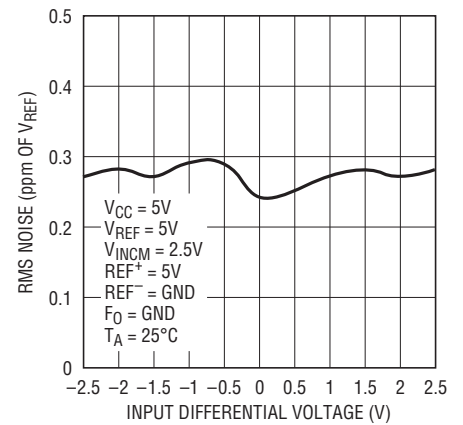

2415 G18

RMS Noise vs V_{INCM}

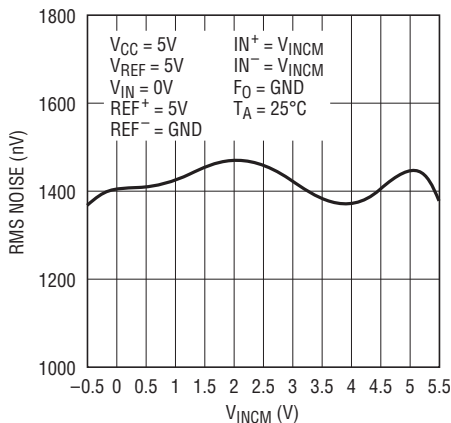

2415 G19

RMS Noise vs Temperature (T_A)

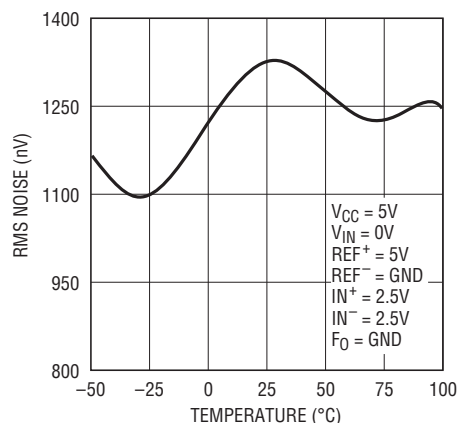

2415 G20

RMS Noise vs V_{CC}

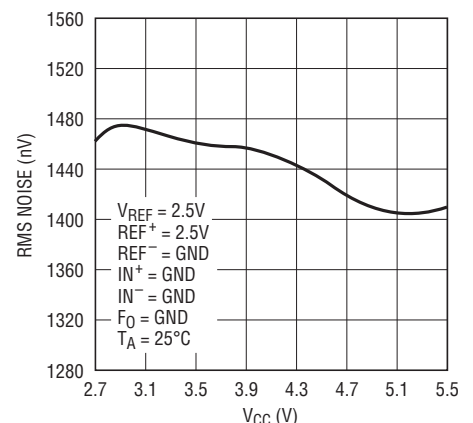

2415 G21

TYPICAL PERFORMANCE CHARACTERISTICS

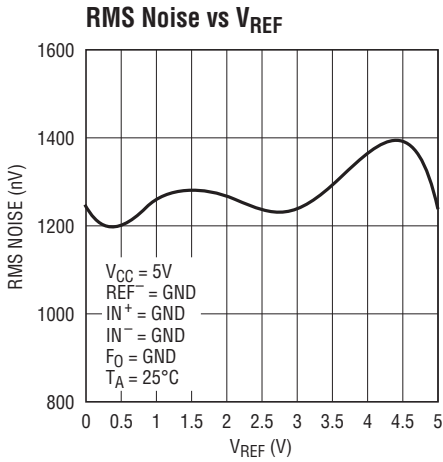

2415 G22

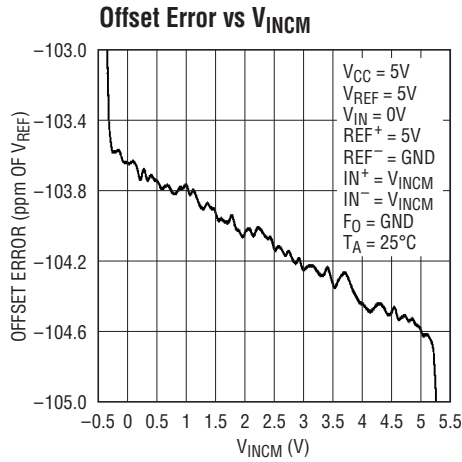

2415 G23

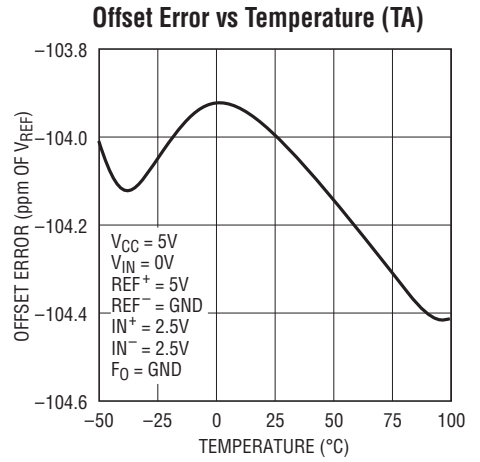

2415 G24

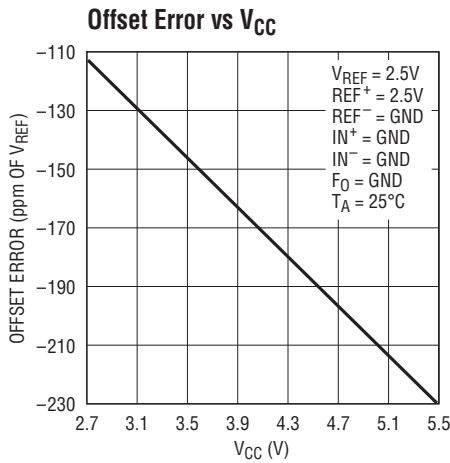

2415 G25

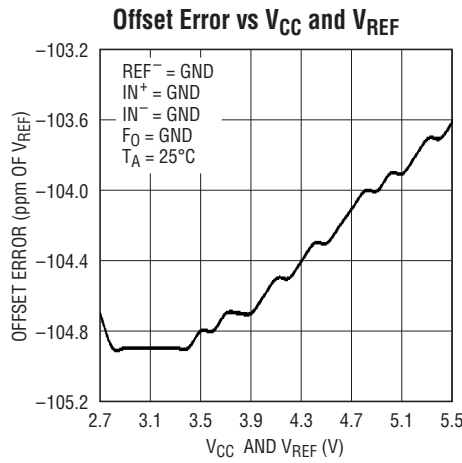

2415 G26

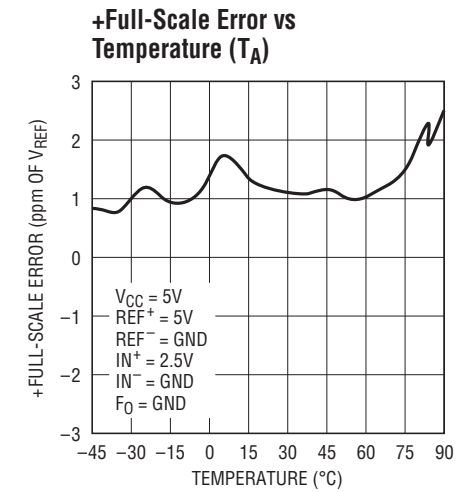

2415 G27

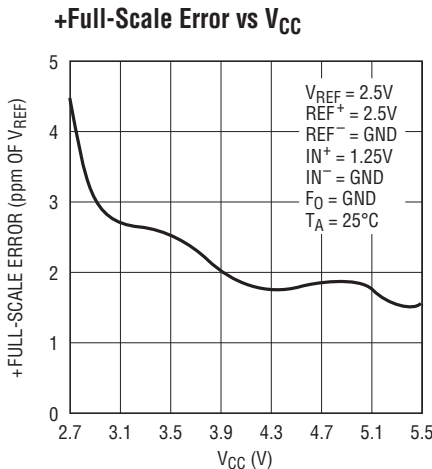

2415 G28

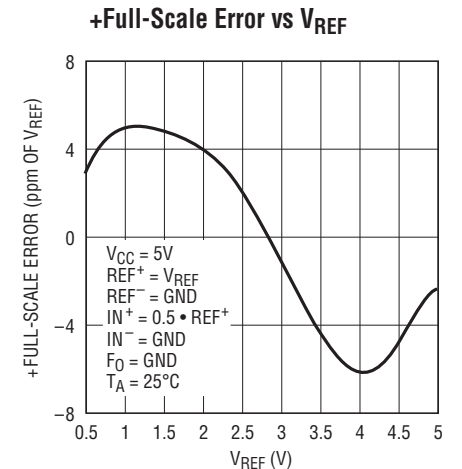

2415 G29

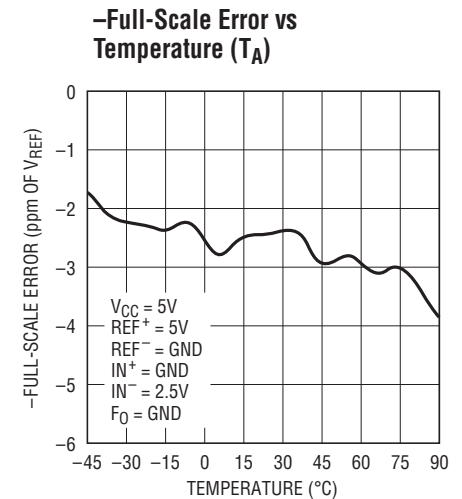

2415 G30

TYPICAL PERFORMANCE CHARACTERISTICS

-Full-Scale Error vs V_{CC}

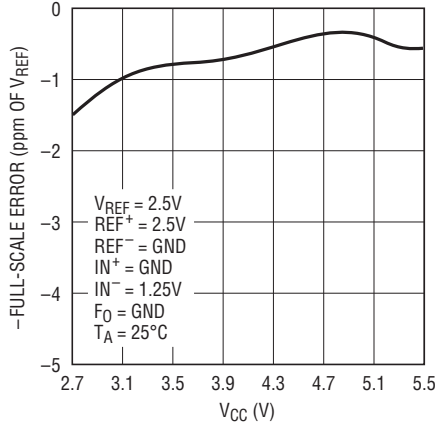

2415 G31

-Full-Scale Error vs V_{REF}

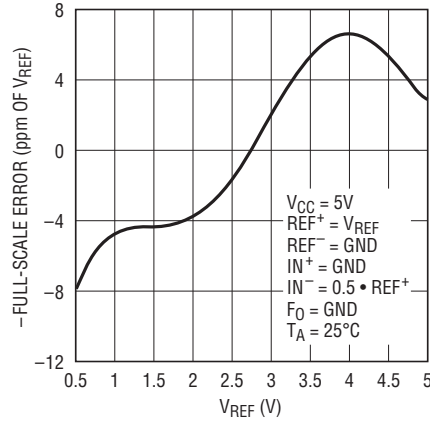

2415 G32

PSRR vs Frequency at V_{CC}

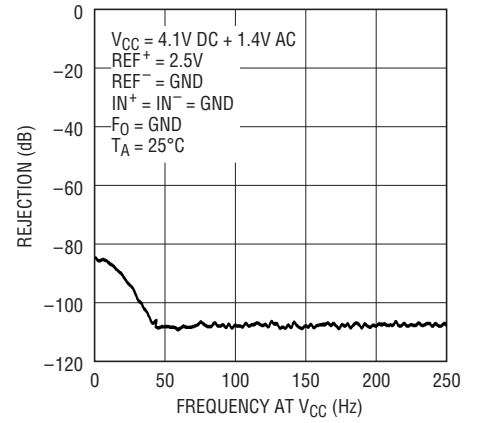

2415 G33

PSRR vs Frequency at V_{CC}

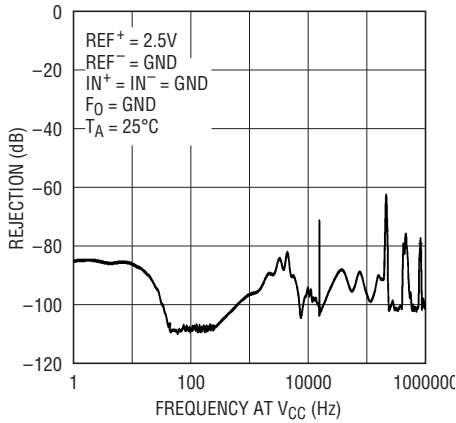

2415 G34

PSRR vs Frequency at V_{CC}

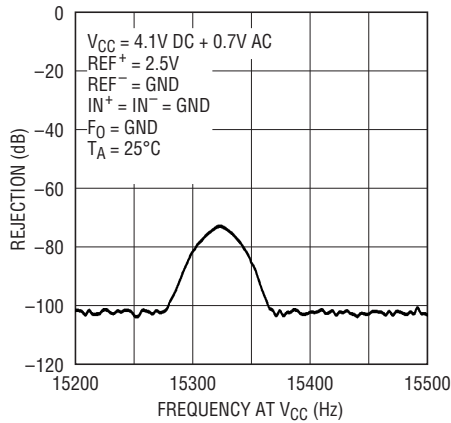

2415 G35

Conversion Current vs Temperature (T_A)

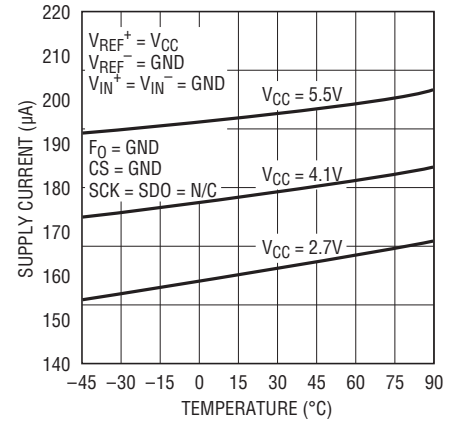

2415 G36

Conversion Current vs Output Data Rate

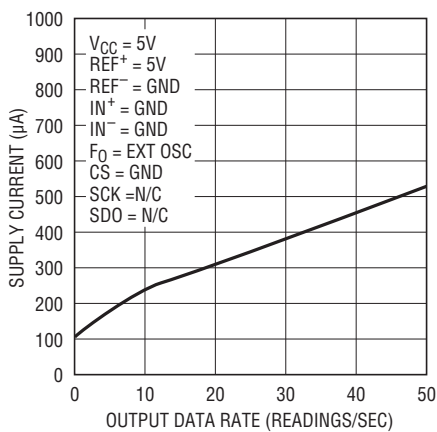

2415 G37

Sleep Current vs Temperature (T_A)

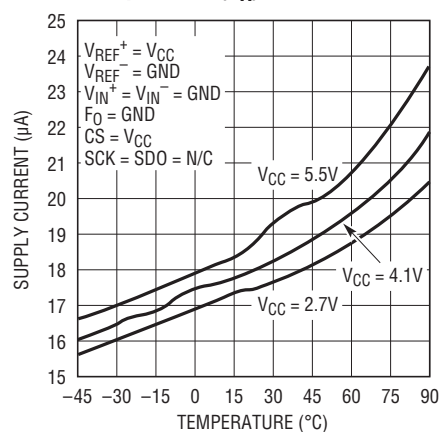

2415 G38

PIN FUNCTIONS

GND (Pins 1, 7, 8, 9, 10, 15, 16): Ground. Multiple ground pins internally connected for optimum ground current flow and V_{CC} decoupling. Connect each one of these pins to a ground plane through a low impedance connection. All seven pins must be connected to ground for proper operation.

V_{CC} (Pin 2): Positive Supply Voltage. Bypass to GND (Pin 1) with a 10 μ F tantalum capacitor in parallel with 0.1 μ F ceramic capacitor as close to the part as possible.

REF⁺ (Pin 3), REF⁻ (Pin 4): Differential Reference Input. The voltage on these pins can have any value between GND and V_{CC} as long as the reference positive input, REF⁺, is maintained more positive than the reference negative input, REF⁻, by at least 0.1V.

IN⁺ (Pin 5), IN⁻ (Pin 6): Differential Analog Input. The voltage on these pins can have any value between GND – 0.3V and V_{CC} + 0.3V. Within these limits the converter bipolar input range ($V_{IN} = IN^+ - IN^-$) extends from $-0.5 \cdot (V_{REF})$ to $0.5 \cdot (V_{REF})$. Outside this input range the converter produces unique overrange and underrange output codes.

\overline{CS} (Pin 11): Active LOW Digital Input. A LOW on this pin enables the SDO digital output and wakes up the ADC. Following each conversion, the ADC automatically enters the Sleep mode and remains in this low power state as long as \overline{CS} is HIGH. A LOW-to-HIGH transition on \overline{CS} during the Data Output transfer aborts the data transfer and starts a new conversion.

SDO (Pin 12): Three-State Digital Output. During the Data Output period, this pin is used as serial data output. When the chip select \overline{CS} is HIGH ($\overline{CS} = V_{CC}$) the SDO pin is in a high impedance state. During the Conversion and Sleep periods, this pin is used as the conversion status output. The conversion status can be observed by pulling \overline{CS} LOW.

SCK (Pin 13): Bidirectional Digital Clock Pin. In Internal Serial Clock Operation mode, SCK is used as digital output for the internal serial interface clock during the Data Output period. In External Serial Clock Operation mode, SCK is used as digital input for the external serial interface clock during the Data Output period. A weak internal pull-up is automatically activated in Internal Serial Clock Operation mode. The Serial Clock Operation mode is determined by the logic level applied to the SCK pin at power up or during the most recent falling edge of \overline{CS} .

F₀ (Pin 14): Frequency Control Pin. Digital input that controls the ADC's notch frequencies and conversion time. When the F₀ pin is connected to V_{CC} (LTC2415 only), the converter uses its internal oscillator and the digital filter first null is located at 50Hz. When the F₀ pin is connected to GND (F₀ = 0V), the converter uses its internal oscillator and the digital filter first null is located at 60Hz (LTC2415) or simultaneous 50Hz/60Hz (LTC2415-1). When F₀ is driven by an external clock signal with a frequency f_{EOSC} , the converter uses this signal as its system clock and the digital filter first null is located at a frequency $f_{EOSC}/2560$.

FUNCTIONAL BLOCK DIAGRAM

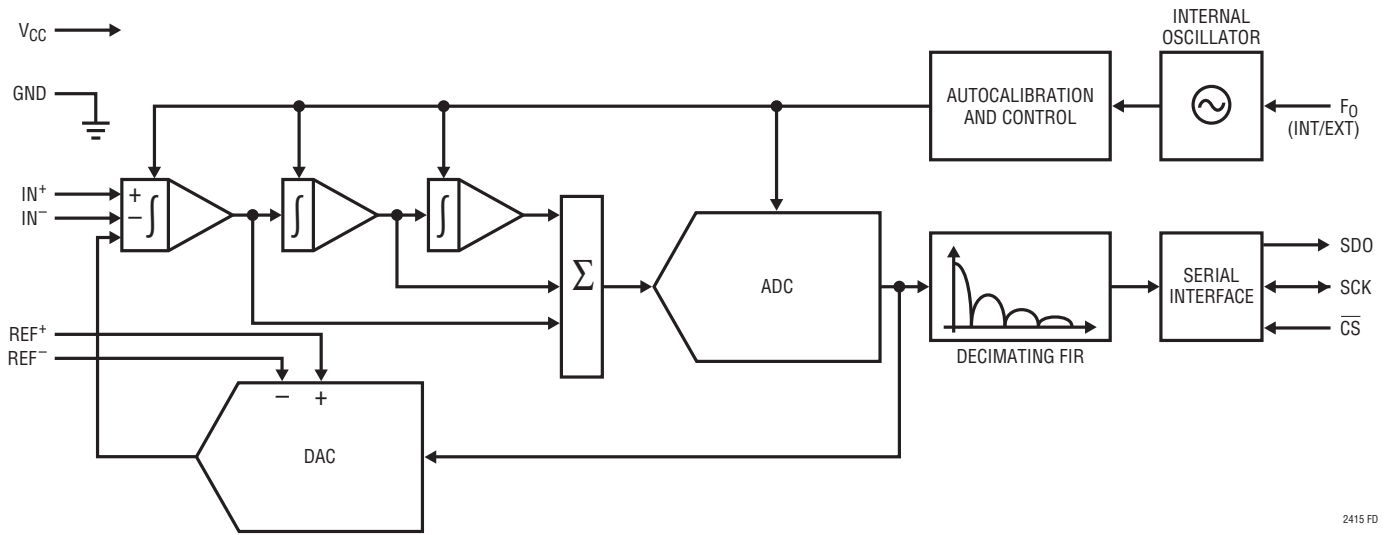
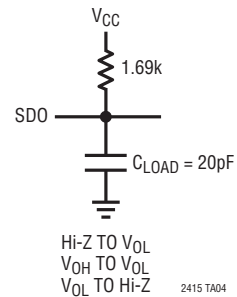
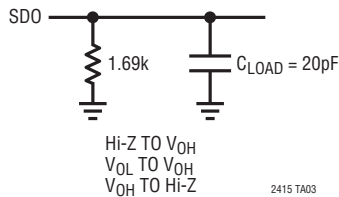

Figure 1. Functional Block Diagram

TEST CIRCUITS



APPLICATIONS INFORMATION

CONVERTER OPERATION

Converter Operation Cycle

The LTC2415/LTC2415-1 are low power, delta-sigma analog-to-digital converters with an easy to use 3-wire serial interface (see Figure 1). Their operation is made up of three states. The converter operating cycle begins with the conversion, followed by the sleep state and ends with the data output (see Figure 2). The 3-wire interface consists of serial data output (SDO), serial clock (SCK) and chip select (\overline{CS}).

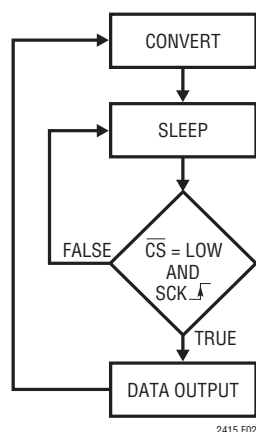

Figure 2. LTC2415 State Transition Diagram

Initially, the LTC2415/LTC2415-1 perform a conversion. Once the conversion is complete, the device enters the sleep state. While in this sleep state, power consumption is reduced by an order of magnitude if \overline{CS} is HIGH. The part remains in the sleep state as long as \overline{CS} is HIGH. The conversion result is held indefinitely in a static shift register while the converter is in the sleep state.

Once \overline{CS} is pulled LOW, the device begins outputting the conversion result. There is no latency in the conversion result. The data output corresponds to the conversion just performed. This result is shifted out on the serial data out pin (SDO) under the control of the serial clock (SCK).

Data is updated on the falling edge of SCK allowing the user to reliably latch data on the rising edge of SCK (see Figure 3). The data output state is concluded once 32 bits are read out of the ADC or when \overline{CS} is brought HIGH. The device automatically initiates a new conversion and the cycle repeats.

Through timing control of the \overline{CS} and SCK pins, the LTC2415/LTC2415-1 offer several flexible modes of operation (internal or external SCK and free-running conversion modes). These various modes do not require programming configuration registers; moreover, they do not disturb the cyclic operation described above. These modes of operation are described in detail in the Serial Interface Timing Modes section.

Conversion Clock

A major advantage the delta-sigma converter offers over conventional type converters is an on-chip digital filter (commonly implemented as a Sinc or Comb filter). For high resolution, low frequency applications, this filter is typically designed to reject line frequencies of 50Hz or 60Hz plus their harmonics. The filter rejection performance is directly related to the accuracy of the converter system clock. The LTC2415/LTC2415-1 incorporate a highly accurate on-chip oscillator. This eliminates the need for external frequency setting components such as crystals or oscillators. Clocked by the on-chip oscillator, the LTC2415 achieves a minimum of 110dB rejection at the line frequency (50Hz or 60Hz $\pm 2\%$), while the LTC2415-1 achieves a minimum of 87db rejection at 50Hz $\pm 2\%$ and 60Hz $\pm 2\%$ simultaneously.

Ease of Use

The LTC2415/LTC2415-1 data output has no latency, filter settling delay or redundant data associated with the conversion cycle. There is a one-to-one correspondence between the conversion and the output data. Therefore, multiplexing multiple analog voltages is easy.

APPLICATIONS INFORMATION

The LTC2415/LTC2415-1 perform a full-scale calibration every conversion cycle. This calibration is transparent to the user and has no effect on the cyclic operation described above. The advantage of continuous calibration is extreme stability of full-scale readings with respect to time, supply voltage change and temperature drift.

Unlike the LTC2410 and LTC2413, the LTC2415 and LTC2415-1 do not perform an offset calibration every conversion cycle. This enables the LTC2415/LTC2415-1 to double their output rate while maintaining line frequency rejection. The initial offset of the LTC2415/LTC2415-1 is within 2mV independent of V_{REF} . Based on the LTC2415/LTC2415-1 new modulator architecture, the temperature drift of the offset is less than 0.01ppm/°C. More information on the LTC2415/LTC2415-1 offset is described in the Offset Accuracy and Drift section of this data sheet.

Power-Up Sequence

The LTC2415/LTC2415-1 automatically enter an internal reset state when the power supply voltage V_{CC} drops below approximately 2.2V. This feature guarantees the integrity of the conversion result and of the serial interface mode selection. (See the 2-wire I/O sections in the Serial Interface Timing Modes section.)

When the V_{CC} voltage rises above this critical threshold, the converter creates an internal power-on-reset (POR) signal with a duration of approximately 0.5ms. The POR signal clears all internal registers. Following the POR signal, the LTC2415/LTC2415-1 start a normal conversion cycle and follow the succession of states described above. The first conversion result following POR is accurate within the specifications of the device if the power supply voltage is restored within the operating range (2.7V to 5.5V) before the end of the POR time interval.

Reference Voltage Range

These converters accept a truly differential external reference voltage. The absolute/common mode voltage specification for the REF^+ and REF^- pins covers the entire range from GND to V_{CC} . For correct converter operation, the REF^+ pin must always be more positive than the REF^- pin.

The LTC2415/LTC2415-1 can accept a differential reference voltage from 0.1V to V_{CC} . The converter output noise is determined by the thermal noise of the front-end circuits, and as such, its value in nanovolts is nearly constant with reference voltage. A decrease in reference voltage will not significantly improve the converter's effective resolution. On the other hand, a reduced reference voltage will improve the converter's overall INL performance.

Input Voltage Range

The analog input is truly differential with an absolute/common mode range for the IN^+ and IN^- input pins extending from $GND - 0.3V$ to $V_{CC} + 0.3V$. Outside these limits, the ESD protection devices begin to turn on and the errors due to input leakage current increase rapidly. Within these limits, the LTC2415/LTC2415-1 convert the bipolar differential input signal, $V_{IN} = IN^+ - IN^-$, from $-FS = -0.5 \cdot V_{REF}$ to $+FS = 0.5 \cdot V_{REF}$ where $V_{REF} = REF^+ - REF^-$. Outside this range, the converters indicate the overrange or the underrange condition using distinct output codes.

Input signals applied to IN^+ and IN^- pins may extend by 300mV below ground and above V_{CC} . In order to limit any fault current, resistors of up to 5k may be added in series with the IN^+ and IN^- pins without affecting the performance of the device. In the physical layout, it is important to maintain the parasitic capacitance of the connection between these series resistors and the corresponding pins as low as possible; therefore, the resistors should be located as close as practical to the pins. The effect of the series resistance on the converter accuracy can be evaluated from the curves presented in the Input Current/Reference Current sections. In addition, series resistors will introduce a temperature dependent offset error due to the input leakage current. A 1nA input leakage current will develop a 1ppm offset error on a 5k resistor if $V_{REF} = 5V$. This error has a very strong temperature dependency.

Output Data Format

The LTC2415/LTC2415-1 serial output data stream is 32 bits long. The first 3 bits represent status information indicating the sign and conversion state. The next 24 bits

APPLICATIONS INFORMATION

are the conversion result, MSB first. The remaining 5 bits are sub LSBs beyond the 24-bit level that may be included in averaging or discarded without loss of resolution. The third and fourth bit together are also used to indicate an underrange condition (the differential input voltage is below $-FS$) or an overrange condition (the differential input voltage is above $+FS$).

Bit 31 (first output bit) is the end of conversion (\overline{EOC}) indicator. This bit is available at the SDO pin during the conversion and sleep states whenever the \overline{CS} pin is LOW. This bit is HIGH during the conversion and goes LOW when the conversion is complete.

Bit 30 (second output bit) is a dummy bit (DMY) and is always LOW.

Bit 29 (third output bit) is the conversion result sign indicator (SIG). If V_{IN} is >0 , this bit is HIGH. If V_{IN} is <0 , this bit is LOW.

Bit 28 (fourth output bit) is the most significant bit (MSB) of the result. This bit in conjunction with Bit 29 also provides the underrange or overrange indication. If both Bit 29 and Bit 28 are HIGH, the differential input voltage is above $+FS$. If both Bit 29 and Bit 28 are LOW, the differential input voltage is below $-FS$.

The function of these bits is summarized in Table 1.

Table 1. LTC2415/LTC2415-1 Status Bits

Input Range	Bit 31 \overline{EOC}	Bit 30 DMY	Bit 29 SIG	Bit 28 MSB
$V_{IN} \geq 0.5 \cdot V_{REF}$	0	0	1	1
$0V \leq V_{IN} < 0.5 \cdot V_{REF}$	0	0	1	0
$-0.5 \cdot V_{REF} \leq V_{IN} < 0V$	0	0	0	1
$V_{IN} < -0.5 \cdot V_{REF}$	0	0	0	0

Bits 28-5 are the 24-bit conversion result MSB first.

Bit 5 is the least significant bit (LSB).

Bits 4-0 are sub LSBs below the 24-bit level. Bits 4-0 may be included in averaging or discarded without loss of resolution.

Data is shifted out of the SDO pin under control of the serial clock (SCK), see Figure 3. Whenever \overline{CS} is HIGH,

SDO remains high impedance and any externally generated SCK clock pulses are ignored by the internal data out shift register.

In order to shift the conversion result out of the device, \overline{CS} must first be driven LOW. \overline{EOC} is seen at the SDO pin of the device once \overline{CS} is pulled LOW. \overline{EOC} changes real time from HIGH to LOW at the completion of a conversion. This signal may be used as an interrupt for an external microcontroller. Bit 31 (\overline{EOC}) can be captured on the first rising edge of SCK. Bit 30 is shifted out of the device on the first falling edge of SCK. The final data bit (Bit 0) is shifted out on the falling edge of the 31st SCK and may be latched on the rising edge of the 32nd SCK pulse. On the falling edge of the 32nd SCK pulse, SDO goes HIGH indicating the initiation of a new conversion cycle. This bit serves as \overline{EOC} (Bit 31) for the next conversion cycle. Table 2 summarizes the output data format.

As long as the voltage on the IN^+ and IN^- pins is maintained within the $-0.3V$ to ($V_{CC} + 0.3V$) absolute maximum operating range, a conversion result is generated for any differential input voltage V_{IN} from $-FS = -0.5 \cdot V_{REF}$ to $+FS = 0.5 \cdot V_{REF}$. For differential input voltages greater than $+FS$, the conversion result is clamped to the value corresponding to the $+FS + 1LSB$. For differential input voltages below $-FS$, the conversion result is clamped to the value corresponding to $-FS - 1LSB$.

Offset Accuracy and Drift

Unlike the LTC2410/LTC2413 and the entire LTC2400 family, the LTC2415/LTC2415-1 do not perform an offset calibration every cycle. The reason for this is to increase the data output rate while maintaining line frequency rejection.

While the initial accuracy of the LTC2415/LTC2415-1 offset is within 2mV (see Figure 4) several unique properties of the LTC2415/LTC2415-1 architecture nearly eliminate the drift of the offset error with respect to temperature and supply.

As shown in Figure 5, the offset variation with temperature is less than 0.6ppm over the complete temperature range of $-50^{\circ}C$ to $100^{\circ}C$. This corresponds to a temperature drift of 0.004ppm/ $^{\circ}C$.

APPLICATIONS INFORMATION

While the variation in offset with supply voltage is proportional to V_{CC} (see Figure 4), several characteristics of this variation can be used to eliminate the effects. First, the variation with respect to supply voltage is linear. Second, the magnitude of the offset error decreases with decreased supply voltage. Third, the offset error increases with

increased reference voltage with an equal and opposite magnitude to the supply voltage variation. As a result, by tying V_{CC} to V_{REF} , the variation with supply can be nearly eliminated, see Figure 6. The variation with supply is less than 2ppm over the entire 2.7V to 5.5V supply range.

Table 2. LTC2415/LTC2415-1 Output Data Format

Differential Input Voltage V_{IN}^*	Bit 31 EOC	Bit 30 DMY	Bit 29 SIG	Bit 28 MSB	Bit 27	Bit 26	Bit 25	...	Bit 0
$V_{IN}^* \geq 0.5 \cdot V_{REF}^{**}$	0	0	1	1	0	0	0	...	0
$0.5 \cdot V_{REF}^{**} - 1LSB$	0	0	1	0	1	1	1	...	1
$0.25 \cdot V_{REF}^{**}$	0	0	1	0	1	0	0	...	0
$0.25 \cdot V_{REF}^{**} - 1LSB$	0	0	1	0	0	1	1	...	1
0	0	0	1	0	0	0	0	...	0
-1LSB	0	0	0	1	1	1	1	...	1
$-0.25 \cdot V_{REF}^{**}$	0	0	0	1	1	0	0	...	0
$-0.25 \cdot V_{REF}^{**} - 1LSB$	0	0	0	1	0	1	1	...	1
$-0.5 \cdot V_{REF}^{**}$	0	0	0	1	0	0	0	...	0
$V_{IN}^* < -0.5 \cdot V_{REF}^{**}$	0	0	0	0	1	1	1	...	1

*The differential input voltage $V_{IN} = IN^+ - IN^-$.

**The differential reference voltage $V_{REF} = REF^+ - REF^-$.

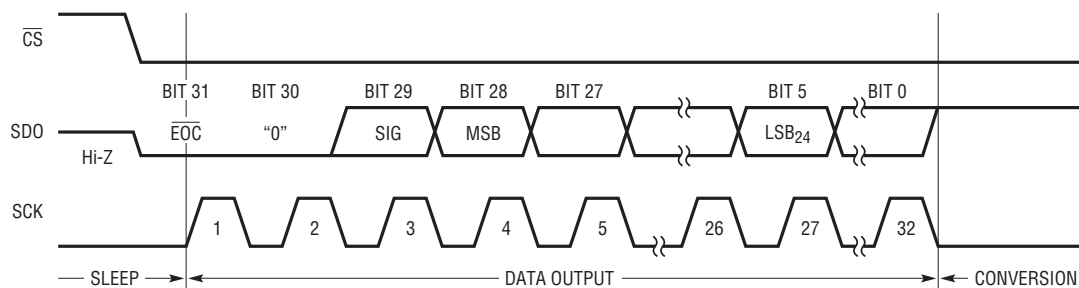

Figure 3. Output Data Timing

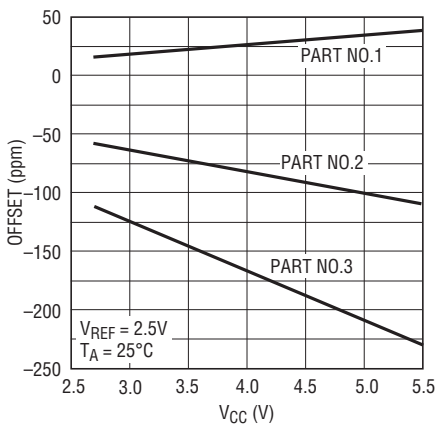

Figure 4. Offset vs V_{CC}

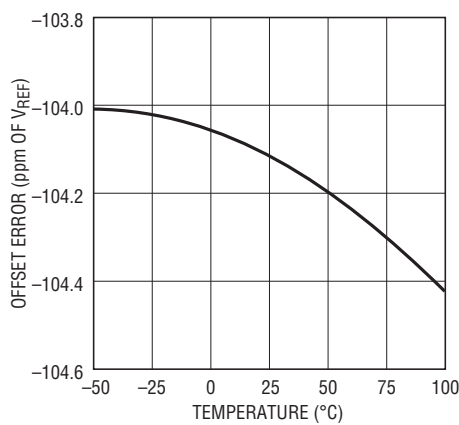

Figure 5. Offset vs Temperature

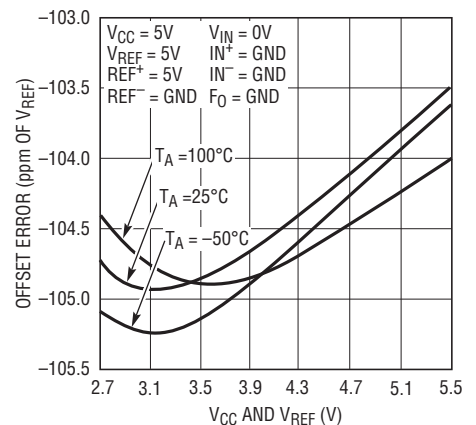

Figure 6. Offset vs V_{CC} ($V_{REF} = V_{CC}$)

APPLICATIONS INFORMATION

Frequency Rejection Selection LTC2415 (F_0)

The LTC2415 internal oscillator provides better than 110dB normal mode rejection at the line frequency and its harmonics for 50Hz $\pm 2\%$ or 60Hz $\pm 2\%$. For 60Hz rejection, F_0 should be connected to GND while for 50Hz rejection the F_0 pin should be connected to V_{CC} .

The selection of 50Hz or 60Hz rejection can also be made by driving F_0 to an appropriate logic level. A selection change during the sleep or data output states will not disturb the converter operation. If the selection is made during the conversion state, the result of the conversion in progress may be outside specifications but the following conversions will not be affected.

When a fundamental rejection frequency different from 50Hz or 60Hz is required or when the converter must be synchronized with an outside source, the LTC2415 can operate with an external conversion clock. The converter automatically detects the presence of an external clock signal at the F_0 pin and turns off the internal oscillator. The frequency f_{EOSC} of the external signal must be at least 2560Hz (1Hz notch frequency) to be detected. The external clock signal duty cycle is not significant as long as the minimum and maximum specifications for the high and low periods t_{HEO} and t_{LEO} are observed.

While operating with an external conversion clock of a frequency f_{EOSC} , the LTC2415 provides better than 110dB normal mode rejection in a frequency range $f_{EOSC}/2560 \pm 4\%$ and its harmonics. The normal mode rejection as a function of the input frequency deviation from $f_{EOSC}/2560$ is shown in Figure 7a.

Whenever an external clock is not present at the F_0 pin, the converter automatically activates its internal oscillator and enters the Internal Conversion Clock mode. The LTC2415 operation will not be disturbed if the change of conversion clock source occurs during the sleep state or during the data output state while the converter uses an external serial clock. If the change occurs during the conversion state, the result of the conversion in progress may be outside specifications but the following conversions will not be affected. If the change occurs during the data output state and the converter is in the Internal SCK mode, the serial clock duty cycle may be affected but the serial data stream will remain valid.

Table 3a summarizes the duration of each state and the achievable output data rate as a function of F_0 .

Frequency Rejection Selection LTC2415-1 (F_0)

The LTC2415-1 internal oscillator provides better than 87dB normal mode rejection over the range of 49Hz to 61.2Hz as shown in Figure 7b. For simultaneous 50Hz/60Hz rejection, F_0 should be connected to GND.

In order to achieve 87dB normal mode rejection of 50Hz $\pm 2\%$ and 60Hz $\pm 2\%$, two consecutive conversions must be averaged. By performing a continuous running average of the two most current results, both simultaneous rejection is achieved and a 2 \times increase in throughput is realized relative to the LTC2413 (see Normal Mode Rejection, Output Rate and Running Averages sections of this data sheet).

When a fundamental rejection frequency different from the range 49Hz to 61.2Hz is required or when the converter must be synchronized with an outside source, the LTC2415-1 can operate with an external conversion clock. The converter automatically detects the presence of an external clock signal at the F_0 pin and turns off the internal oscillator. The frequency f_{EOSC} of the external signal must be at least 2560Hz to be detected. The external clock signal duty cycle is not significant as long as the minimum and maximum specifications for the high and low periods, t_{HEO} and t_{LEO} , are observed.

While operating with an external conversion clock of a frequency f_{EOSC} , the LTC2415-1 provides better than 110dB normal mode rejection in a frequency range $f_{EOSC}/2560 \pm 4\%$. The normal mode rejection as a function of the input frequency deviation from $f_{EOSC}/2560$ is shown in Figure 7a and Figure 7c shows the normal mode rejection with running averages included.

Whenever an external clock is not present at the F_0 pin the converter automatically activates its internal oscillator and enters the Internal Conversion Clock mode. The LTC2415-1 operation will not be disturbed if the change of conversion clock source occurs during the sleep state or during the data output state while the converter uses an external serial clock. If the change occurs during the conversion state, the result of the conversion in progress may be outside specifications but the following conversions will not be affected. If the change occurs during the

2415fa

APPLICATIONS INFORMATION

data output state and the converter is in the Internal SCK mode, the serial clock duty cycle may be affected but the serial data stream will remain valid.

Table 3b summarizes the duration of each state and the achievable output data rate as a function of F_0 .

Serial Interface Pins

The LTC2415/LTC2415-1 transmit the conversion results and receive the start of conversion command through a synchronous 3-wire interface. During the conversion and sleep states, this interface can be used to assess the converter status and during the data output state it is used to read the conversion result.

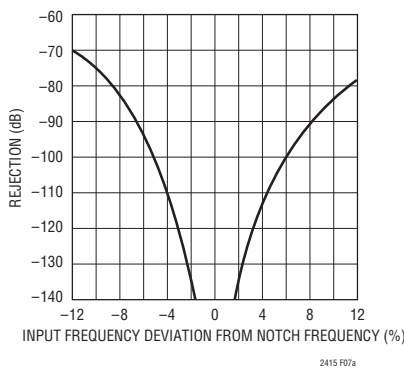

Figure 7a. LTC2415/LTC2415-1 Normal Mode Rejection When Using an External Oscillator of Frequency f_{EOSC} without Running Averages

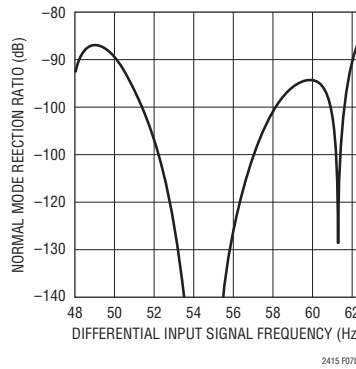

Figure 7b. LTC2415-1 Normal Mode Rejection When Using an Internal Oscillator with Running Averages

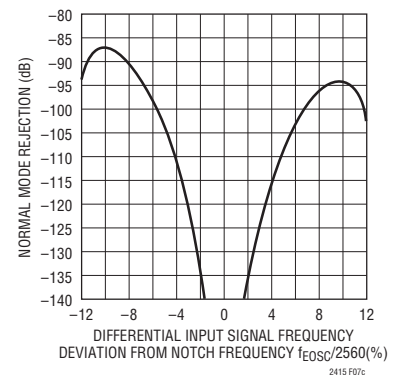

Figure 7c. LTC2415/LTC2415-1 Normal Mode Rejection When Using an External Oscillator of Frequency f_{EOSC} with Running Averages

Table 3a. LTC2415 State Duration

State	Operating Mode		Duration
CONVERT	Internal Oscillator	$F_0 = \text{LOW}$, (60Hz Rejection)	66.6ms, Output Data Rate ≤ 15 Readings/s
		$F_0 = \text{HIGH}$, (50Hz Rejection)	80ms, Output Data Rate ≤ 12.4 Readings/s
	External Oscillator	$F_0 = \text{External Oscillator with Frequency } f_{EOSC} \text{ kHz (} f_{EOSC}/2560 \text{ Rejection)}$	$10278/f_{EOSC}s$, Output Data Rate $\leq f_{EOSC}/10278$ Readings/s
SLEEP			As Long As $\overline{CS} = \text{HIGH}$ Until $\overline{CS} = \text{LOW}$ and $SCK \downarrow$
DATA OUTPUT	Internal Serial Clock	$F_0 = \text{LOW/HIGH}$, (Internal Oscillator)	As Long As $\overline{CS} = \text{LOW}$ But Not Longer Than 1.67ms (32 SCK cycles)
		$F_0 = \text{External Oscillator with Frequency } f_{EOSC} \text{ kHz}$	As Long As $\overline{CS} = \text{LOW}$ But Not Longer Than $256/f_{EOSC}ms$ (32 SCK cycles)
	External Serial Clock with Frequency $f_{SCK} \text{ kHz}$		As Long As $\overline{CS} = \text{LOW}$ But Not Longer Than $32/f_{SCK}ms$ (32 SCK cycles)

Table 3b. LTC2415-1 State Duration

State	Operating Mode		Duration
CONVERT	Internal Oscillator	$F_0 = \text{LOW}$ Simultaneous 50Hz/60Hz Rejection	72.8ms, Output Data Rate ≤ 14 Readings/s
	External Oscillator	$F_0 = \text{External Oscillator with Frequency } f_{EOSC} \text{ kHz (} f_{EOSC}/2560 \text{ Rejection)}$	$10278/f_{EOSC}s$, Output Data Rate $\leq f_{EOSC}/10278$ Readings/s
SLEEP			As Long As $\overline{CS} = \text{HIGH}$ Until $\overline{CS} = \text{LOW}$ and $SCK \downarrow$
DATA OUTPUT	Internal Serial Clock	$F_0 = \text{LOW/HIGH}$, (Internal Oscillator)	As Long As $\overline{CS} = \text{LOW}$ But Not Longer Than 1.83ms (32 SCK cycles)
		$F_0 = \text{External Oscillator with Frequency } f_{EOSC} \text{ kHz}$	As Long As $\overline{CS} = \text{LOW}$ But Not Longer Than $256/f_{EOSC}ms$ (32 SCK cycles)
	External Serial Clock with Frequency $f_{SCK} \text{ kHz}$		As Long As $\overline{CS} = \text{LOW}$ But Not Longer Than $32/f_{SCK}ms$ (32 SCK cycles)

APPLICATIONS INFORMATION

Serial Clock Input/Output (SCK)

The serial clock signal present on SCK (Pin 13) is used to synchronize the data transfer. Each bit of data is shifted out the SDO pin on the falling edge of the serial clock.

In the Internal SCK mode of operation, the SCK pin is an output and the LTC2415/LTC2415-1 create their own serial clock by dividing the internal conversion clock by 8. In the External SCK mode of operation, the SCK pin is used as input. The internal or external SCK mode is selected on power-up and then reselected every time a HIGH-to-LOW transition is detected at the \overline{CS} pin. If SCK is HIGH or floating at power-up or during this transition, the converter enters the internal SCK mode. If SCK is LOW at power-up or during this transition, the converter enters the external SCK mode.

Serial Data Output (SDO)

The serial data output pin, SDO (Pin 12), provides the result of the last conversion as a serial bit stream (MSB first) during the data output state. In addition, the SDO pin is used as an end of conversion indicator during the conversion and sleep states.

When \overline{CS} (Pin 11) is HIGH, the SDO driver is switched to a high impedance state. This allows sharing the serial interface with other devices. If \overline{CS} is LOW during the convert or sleep state, SDO will output \overline{EOC} . If \overline{CS} is LOW during the conversion phase, the \overline{EOC} bit appears HIGH on the SDO pin. Once the conversion is complete, \overline{EOC} goes LOW. The device remains in the sleep state until the first rising edge of SCK occurs while $\overline{CS} = \text{LOW}$.

Chip Select Input (\overline{CS})

The active LOW chip select, \overline{CS} (Pin 11), is used to test the conversion status and to enable the data output transfer as described in the previous sections.

In addition, the \overline{CS} signal can be used to trigger a new conversion cycle before the entire serial data transfer has been completed. The LTC2415/LTC2415-1 will abort any serial data transfer in progress and start a new conversion cycle anytime a LOW-to-HIGH transition is detected at the \overline{CS} pin after the converter has entered the data output state (i.e., after the first rising edge of SCK occurs with $\overline{CS} = \text{LOW}$).

Finally, \overline{CS} can be used to control the free-running modes of operation, see Serial Interface Timing Modes section. Grounding \overline{CS} will force the ADC to continuously convert at the maximum output rate selected by F_0 . Tying a capacitor to \overline{CS} will reduce the output rate and power dissipation by a factor proportional to the capacitor's value, see Figures 15 to 17.

SERIAL INTERFACE TIMING MODES

The LTC2415/LTC2415-1 3-wire interface is SPI and MICROWIRE compatible. This interface offers several flexible modes of operation. These include internal/external serial clock, 2- or 3-wire I/O, single cycle conversion and auto-start. The following sections describe each of these serial interface timing modes in detail. In all these cases, the converter can use the internal oscillator ($F_0 = \text{LOW}$ or $F_0 = \text{HIGH}$) or an external oscillator connected to the F_0 pin. Refer to Table 4 for a summary.

Table 4. LTC2415/LTC2415-1 Interface Timing Modes

Configuration	SCK Source	Conversion Cycle Control	Data Output Control	Connection and Waveforms
External SCK, Single Cycle Conversion	External	\overline{CS} and SCK	\overline{CS} and SCK	Figures 8, 9
External SCK, 2-Wire I/O	External	SCK	SCK	Figure 10
Internal SCK, Single Cycle Conversion	Internal	$\overline{CS} \downarrow$	$\overline{CS} \downarrow$	Figures 11, 12
Internal SCK, 2-Wire I/O, Continuous Conversion	Internal	Continuous	Internal	Figure 13
Internal SCK, Auto-start Conversion	Internal	C_{EXT}	Internal	Figure 14

APPLICATIONS INFORMATION

External Serial Clock, Single Cycle Operation (SPI/MICROWIRE Compatible)

This timing mode uses an external serial clock to shift out the conversion result and a \overline{CS} signal to monitor and control the state of the conversion cycle, see Figure 8.

The serial clock mode is selected on the falling edge of \overline{CS} . To select the external serial clock mode, the serial clock pin (SCK) must be LOW during each \overline{CS} falling edge.

The serial data output pin (SDO) is Hi-Z as long as \overline{CS} is HIGH. At any time during the conversion cycle, \overline{CS} may be pulled LOW in order to monitor the state of the converter. While \overline{CS} is pulled LOW, \overline{EOC} is output to the SDO pin. $\overline{EOC} = 1$ while a conversion is in progress and $\overline{EOC} = 0$ if the device is in the sleep state. Independent of \overline{CS} , the device automatically enters the sleep state once the conversion is complete. While in the sleep state, if \overline{CS} is high, the LTC2415/LTC2415-1 power consumption is reduced by an order of magnitude

When the device is in the sleep state ($\overline{EOC} = 0$), its conversion result is held in an internal static shift register. The device remains in the sleep state until the first rising edge of SCK is seen while \overline{CS} is LOW. Data is shifted out the SDO pin on each falling edge of SCK. This enables external circuitry to latch the output on the rising edge of SCK. \overline{EOC} can be latched on the first rising edge of SCK and the last bit of the conversion result can be latched on

the 32nd rising edge of SCK. On the 32nd falling edge of SCK, the device begins a new conversion. SDO goes HIGH ($\overline{EOC} = 1$) indicating a conversion is in progress.

At the conclusion of the data cycle, \overline{CS} may remain LOW and \overline{EOC} monitored as an end-of-conversion interrupt. Alternatively, \overline{CS} may be driven HIGH setting SDO to Hi-Z. As described above, \overline{CS} may be pulled LOW at any time in order to monitor the conversion status.

Typically, \overline{CS} remains LOW during the data output state. However, the data output state may be aborted by pulling \overline{CS} HIGH anytime between the first rising edge and the 32nd falling edge of SCK, see Figure 9. On the rising edge of \overline{CS} , the device aborts the data output state and immediately initiates a new conversion. This is useful for systems not requiring all 32 bits of output data, aborting an invalid conversion cycle or synchronizing the start of a conversion.

External Serial Clock, 2-Wire I/O

This timing mode utilizes a 2-wire serial I/O interface. The conversion result is shifted out of the device by an externally generated serial clock (SCK) signal, see Figure 10. \overline{CS} may be permanently tied to ground, simplifying the user interface or isolation barrier.

The external serial clock mode is selected at the end of the power-on reset (POR) cycle. The POR cycle is concluded

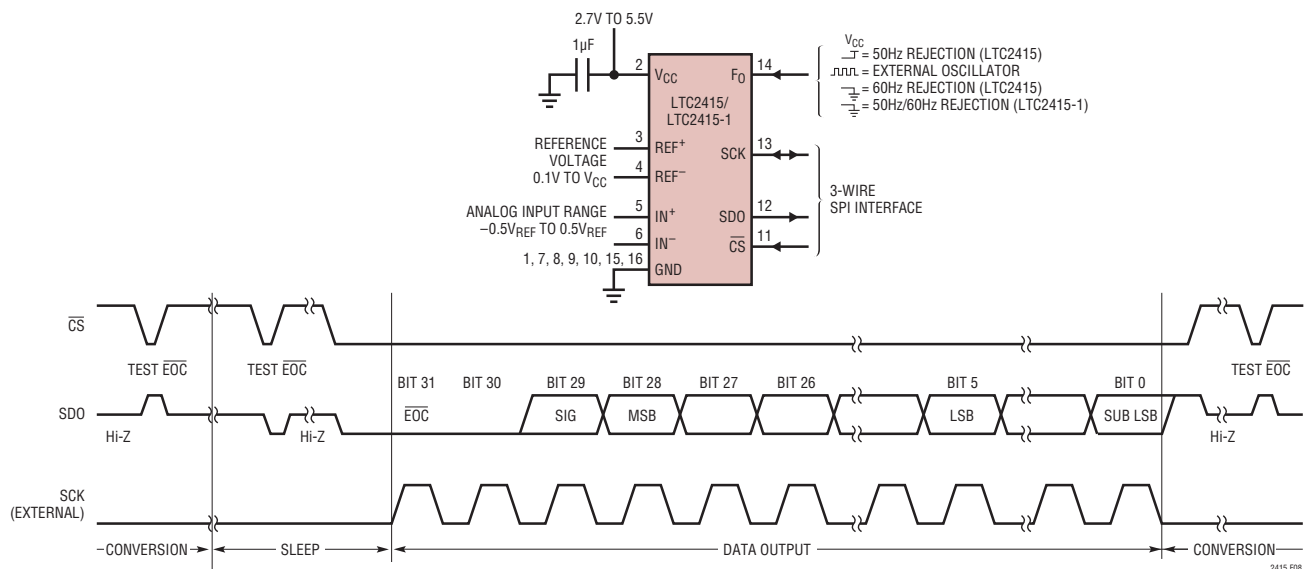

APPLICATIONS INFORMATION

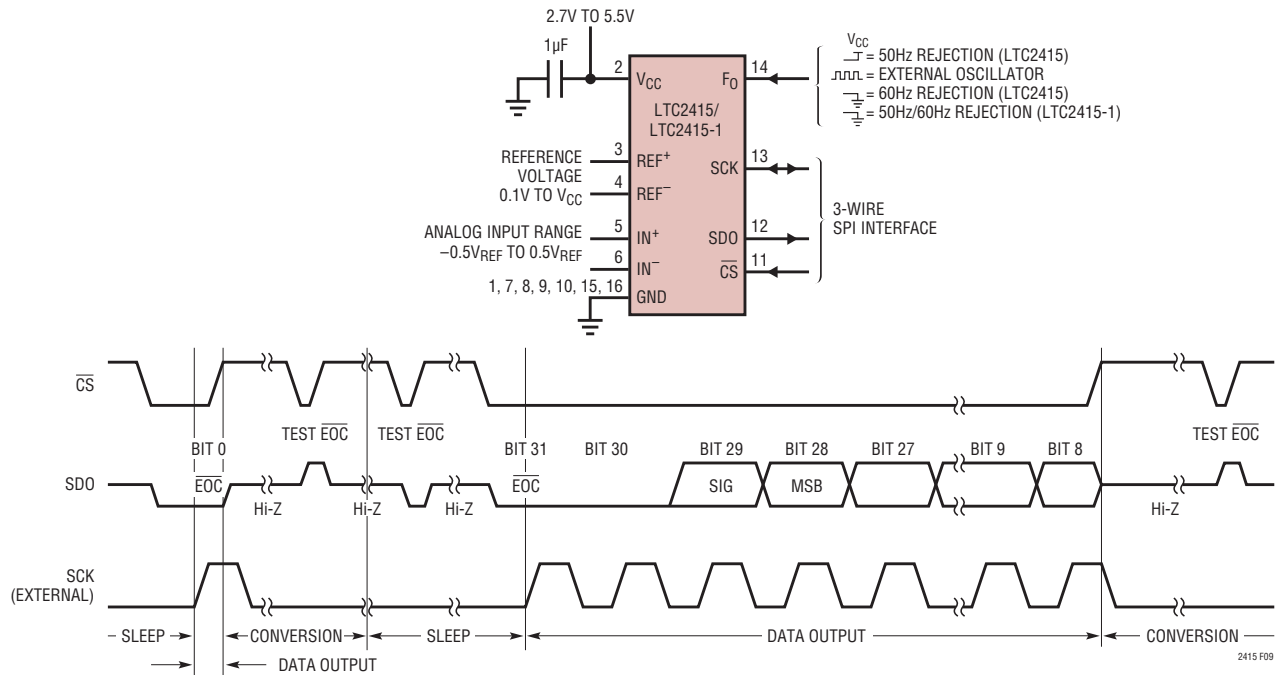

Figure 9. External Serial Clock, Reduced Data Output Length

approximately 0.5ms after V_{CC} exceeds 2.2V. The level applied to SCK at this time determines if SCK is internal or external. SCK must be driven LOW prior to the end of POR in order to enter the external serial clock timing mode.

Since \overline{CS} is tied LOW, the end-of-conversion (\overline{EOC}) can be continuously monitored at the SDO pin during the convert and sleep states. \overline{EOC} may be used as an interrupt to an external controller indicating the conversion result is ready. $\overline{EOC} = 1$ while the conversion is in progress and $\overline{EOC} = 0$ once the conversion enters the sleep state. On the falling edge of \overline{EOC} , the conversion result is loaded into an internal static shift register. The device remains in the sleep state until the first rising edge of SCK. Data is shifted out the SDO pin on each falling edge of SCK enabling external circuitry to latch data on the rising edge of SCK. \overline{EOC} can be latched on the first rising edge of SCK. On the 32nd falling edge of SCK, SDO goes HIGH ($\overline{EOC} = 1$) indicating a new conversion has begun.

Internal Serial Clock, Single Cycle Operation

This timing mode uses an internal serial clock to shift out the conversion result and a \overline{CS} signal to monitor and control the state of the conversion cycle, see Figure 11.

In order to select the internal serial clock timing mode, the serial clock pin (SCK) must be floating (Hi-Z) or pulled HIGH prior to the falling edge of \overline{CS} . The device will not enter the internal serial clock mode if SCK is driven LOW on the falling edge of \overline{CS} . An internal weak pull-up resistor is active on the SCK pin during the falling edge of \overline{CS} ; therefore, the internal serial clock timing mode is automatically selected if SCK is not externally driven.

The serial data output pin (SDO) is Hi-Z as long as \overline{CS} is HIGH. At any time during the conversion cycle, \overline{CS} may be pulled LOW in order to monitor the state of the converter. Once \overline{CS} is pulled LOW, SCK goes LOW and \overline{EOC} is output to the SDO pin. $\overline{EOC} = 1$ while a conversion is in progress and $\overline{EOC} = 0$ if the device is in the sleep state.

When testing \overline{EOC} , if the conversion is complete ($\overline{EOC} = 0$), the device will exit the sleep state and enter the data output state if \overline{CS} remains LOW. In order to prevent the device from exiting the sleep state, \overline{CS} must be pulled HIGH before the first rising edge of SCK. In the internal SCK timing mode, SCK goes HIGH and the device begins outputting data at time $t_{EOCtest}$ after the falling edge of \overline{CS} (if $\overline{EOC} = 0$) or $t_{EOCtest}$ after \overline{EOC} goes LOW (if \overline{CS} is LOW

APPLICATIONS INFORMATION

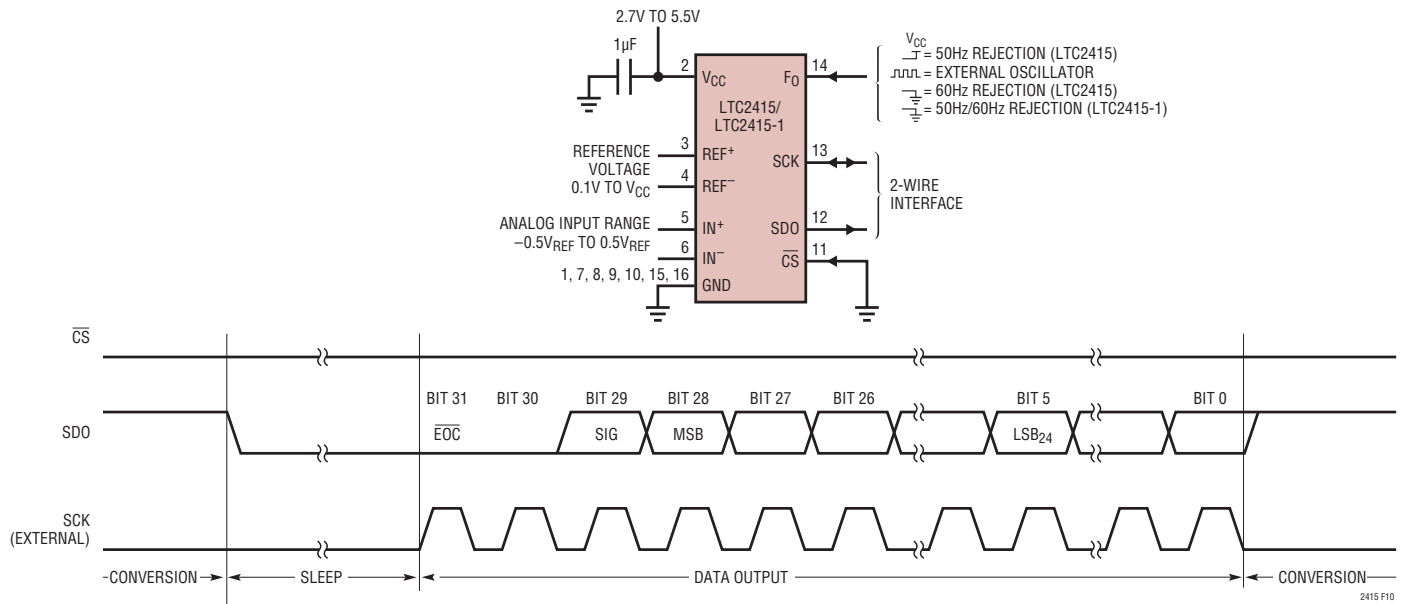

Figure 10. External Serial Clock, $\overline{CS} = 0$ Operation (2-Wire)

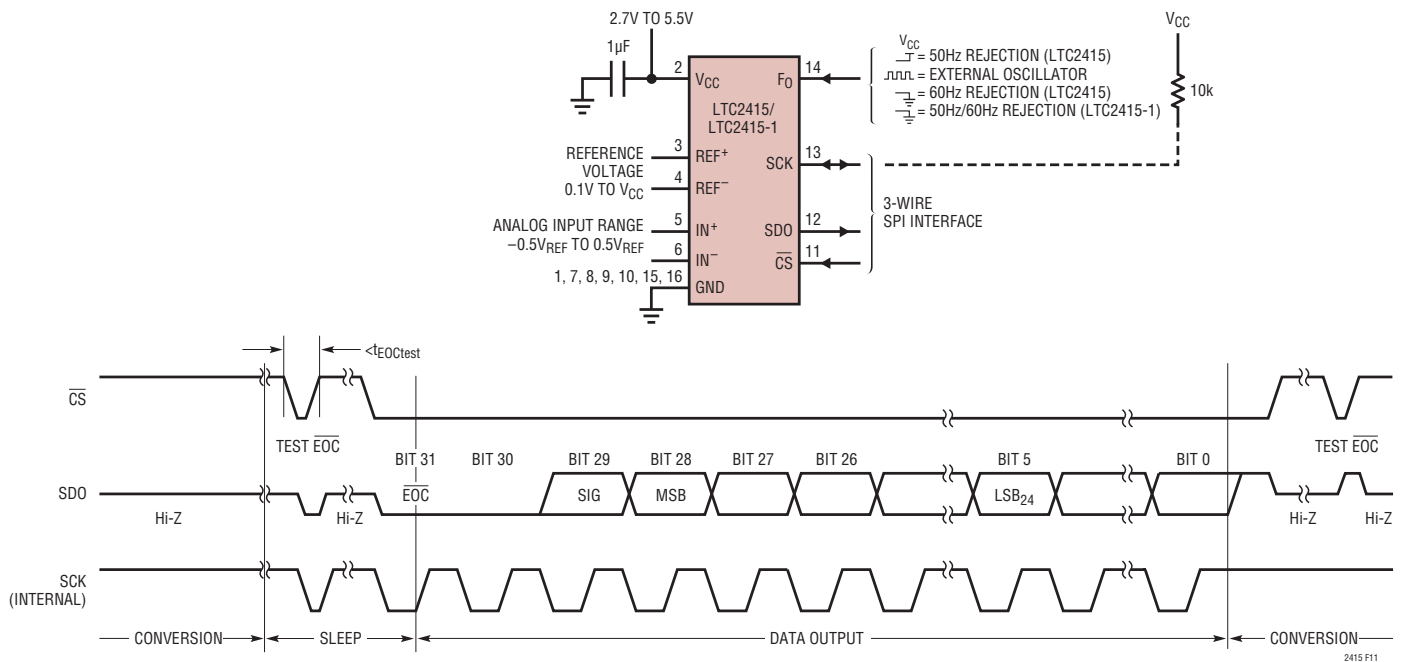

Figure 11. Internal Serial Clock, Single Cycle Operation

APPLICATIONS INFORMATION

during the falling edge of \overline{EOC} . The value of $t_{EOCtest}$ is $23\mu s$ (LTC2415), $26\mu s$ (LTC2415-1) if the device is using its internal oscillator ($F_0 = \text{logic LOW or HIGH}$). If F_0 is driven by an external oscillator of (LTC2415-1) frequency f_{EOSC} , then $t_{EOCtest}$ is $3.6/f_{EOSC}$. If \overline{CS} is pulled HIGH before time $t_{EOCtest}$, the device remains in the sleep state. The conversion result is held in the internal static shift register.

If \overline{CS} remains LOW longer than $t_{EOCtest}$, the first rising edge of SCK will occur and the conversion result is serially shifted out of the SDO pin. The data output cycle begins on this first rising edge of SCK and concludes after the 32nd rising edge. Data is shifted out the SDO pin on each falling edge of SCK. The internally generated serial clock is output to the SCK pin. This signal may be used to shift the conversion result into external circuitry. \overline{EOC} can be latched on the first rising edge of SCK and the last bit of the conversion result on the 32nd rising edge of SCK. After the 32nd rising edge, SDO goes HIGH ($\overline{EOC} = 1$), SCK stays HIGH and a new conversion starts.

Typically, \overline{CS} remains LOW during the data output state. However, the data output state may be aborted by pulling \overline{CS} HIGH anytime between the first and 32nd rising edge

of SCK, see Figure 12. On the rising edge of \overline{CS} , the device aborts the data output state and immediately initiates a new conversion. This is useful for systems not requiring all 32 bits of output data, aborting an invalid conversion cycle, or synchronizing the start of a conversion. If \overline{CS} is pulled HIGH while the converter is driving SCK LOW, the internal pull-up is not available to restore SCK to a logic HIGH state. This will cause the device to exit the internal serial clock mode on the next falling edge of \overline{CS} . This can be avoided by adding an external 10k pull-up resistor to the SCK pin or by never pulling \overline{CS} HIGH when SCK is LOW.

Whenever SCK is LOW, the LTC2415/LTC2415-1 internal pull-up at pin SCK is disabled. Normally, SCK is not externally driven if the device is in the internal SCK timing mode. However, certain applications may require an external driver on SCK. If this driver goes Hi-Z after outputting a LOW signal, the LTC2415/LTC2415-1 internal pull-up remains disabled. Hence, SCK remains LOW. On the next falling edge of \overline{CS} , the device is switched to the external SCK timing mode. By adding an external 10k pull-up resistor to SCK, this pin goes HIGH once the external driver goes Hi-Z. On the next \overline{CS} falling edge, the device will remain in the internal SCK timing mode.

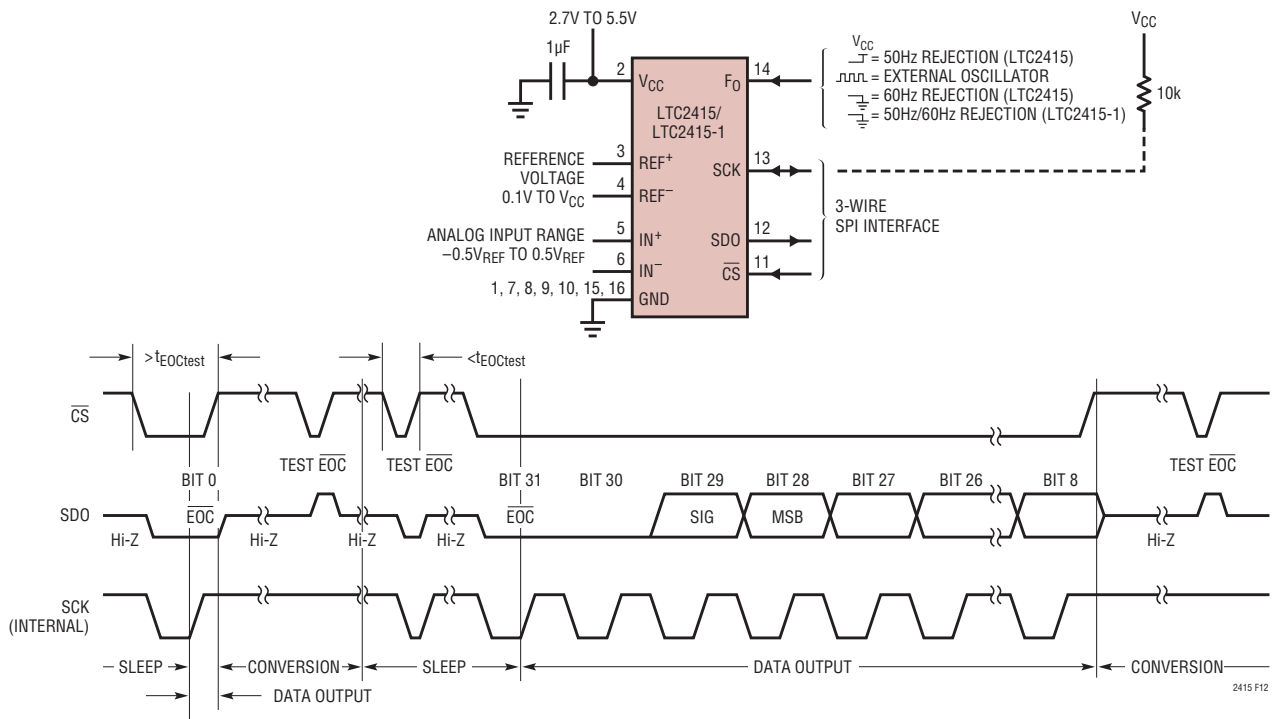

Figure 12. Internal Serial Clock, Reduced Data Output Length

APPLICATIONS INFORMATION

A similar situation may occur during the sleep state when \overline{CS} is pulsed HIGH-LOW-HIGH in order to test the conversion status. If the device is in the sleep state ($\overline{EOC} = 0$), SCK will go LOW. Once \overline{CS} goes HIGH (within the time period defined above as $t_{EOCtest}$), the internal pull-up is activated. For a heavy capacitive load on the SCK pin, the internal pull-up may not be adequate to return SCK to a HIGH level before \overline{CS} goes low again. This is not a concern under normal conditions where \overline{CS} remains LOW after detecting $\overline{EOC} = 0$. This situation is easily overcome by adding an external 10k pull-up resistor to the SCK pin.

Internal Serial Clock, 2-Wire I/O, Continuous Conversion

This timing mode uses a 2-wire, all output (SCK and SDO) interface. The conversion result is shifted out of the device by an internally generated serial clock (SCK) signal, see Figure 13. \overline{CS} may be permanently tied to ground, simplifying the user interface or isolation barrier.

The internal serial clock mode is selected at the end of the power-on reset (POR) cycle. The POR cycle is concluded approximately 0.5ms after V_{CC} exceeds 2.2V. An internal

weak pull-up is active during the POR cycle; therefore, the internal serial clock timing mode is automatically selected if SCK is not externally driven LOW (if SCK is loaded such that the internal pull-up cannot pull the pin HIGH, the external SCK mode will be selected).

During the conversion, the SCK and the serial data output pin (SDO) are HIGH ($\overline{EOC} = 1$). Once the conversion is complete, SCK and SDO go LOW ($\overline{EOC} = 0$) indicating the conversion has finished and the device has entered the low power sleep state. The part remains in the sleep state a minimum amount of time (1/2 the internal SCK period) then immediately begins outputting data. The data output cycle begins on the first rising edge of SCK and ends after the 32nd rising edge. Data is shifted out the SDO pin on each falling edge of SCK. The internally generated serial clock is output to the SCK pin. This signal may be used to shift the conversion result into external circuitry. \overline{EOC} can be latched on the first rising edge of SCK and the last bit of the conversion result can be latched on the 32nd rising edge of SCK. After the 32nd rising edge, SDO goes HIGH ($\overline{EOC} = 1$) indicating a new conversion is in progress. SCK remains HIGH during the conversion.

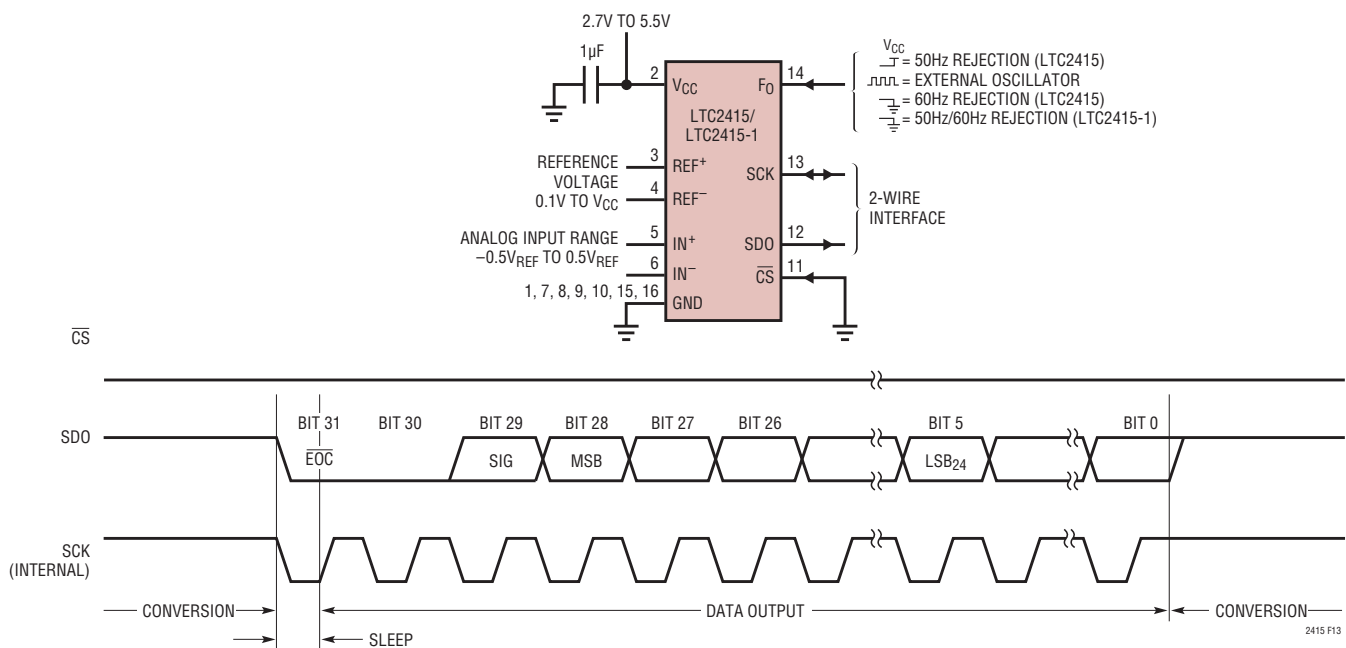

Figure 13. Internal Serial Clock, Continuous Operation

APPLICATIONS INFORMATION

Internal Serial Clock, Auto-start Conversion

This timing mode is identical to the internal serial clock, 2-wire I/O described above with one additional feature. Instead of grounding \overline{CS} , an external timing capacitor is tied to \overline{CS} .

While the conversion is in progress, the \overline{CS} pin is held HIGH by an internal weak pull-up. Once the conversion is complete, the device enters the low power sleep state and an internal 25nA current source begins discharging the capacitor tied to \overline{CS} , see Figure 14. The time the converter spends in the sleep state is determined by the value of the external timing capacitor, see Figures 15 and 16. Once the voltage at \overline{CS} falls below an internal threshold ($\approx 1.4V$), the device automatically begins outputting data. The data output cycle begins on the first rising edge of SCK and ends on the 32nd rising edge. Data is shifted out the SDO pin on each falling edge of SCK. The internally generated serial clock is output to the SCK pin. This signal may be used to shift the conversion result into external circuitry. After the 32nd rising edge, \overline{CS} is pulled HIGH and a new

conversion is immediately started. This is useful in applications requiring periodic monitoring and ultralow power. Figure 17 shows the average supply current as a function of capacitance on \overline{CS} .

It should be noticed that the external capacitor discharge current is kept very small in order to decrease the converter power dissipation in the sleep state. In the auto-start mode, the analog voltage on the \overline{CS} pin cannot be observed without disturbing the converter operation using a regular oscilloscope probe. When using this configuration, it is important to minimize the external leakage current at the \overline{CS} pin by using a low leakage external capacitor and properly cleaning the PCB surface.

The internal serial clock mode is selected every time the voltage on the \overline{CS} pin crosses an internal threshold voltage. An internal weak pull-up at the SCK pin is active while \overline{CS} is discharging; therefore, the internal serial clock timing mode is automatically selected if SCK is floating. It is important to ensure there are no external drivers pulling SCK LOW while \overline{CS} is discharging.

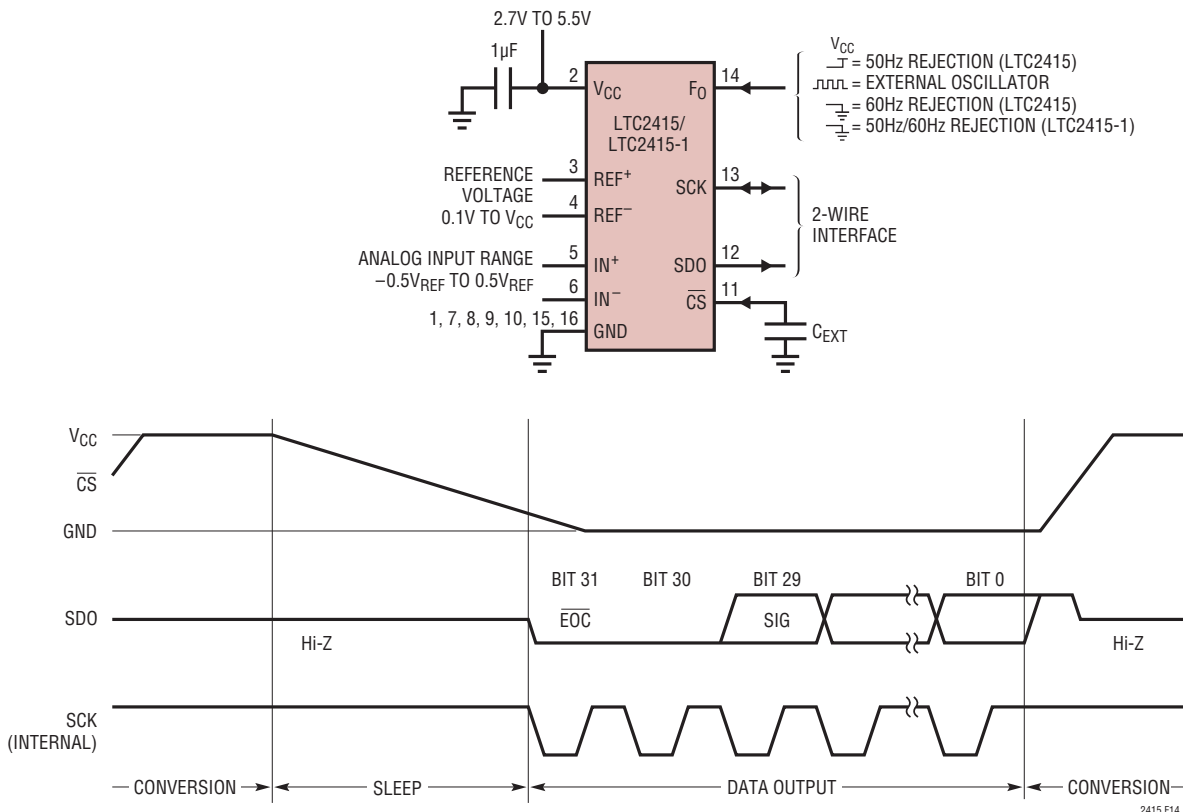

Figure 14. Internal Serial Clock, Auto-start Operation

2415fa

APPLICATIONS INFORMATION

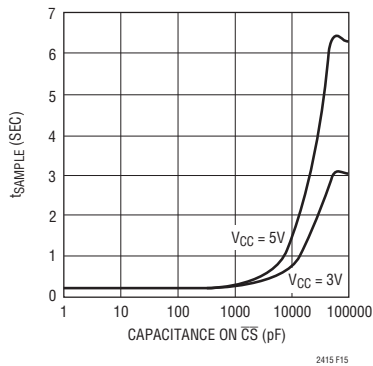

Figure 15. \overline{CS} Capacitance vs t_{SAMPLE}

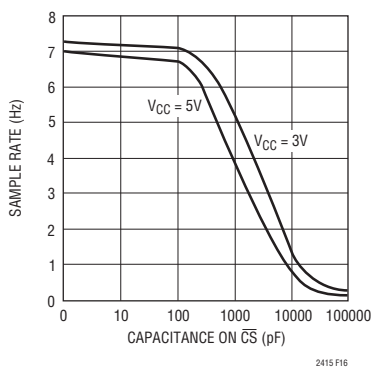

Figure 16. \overline{CS} Capacitance vs Output Rate

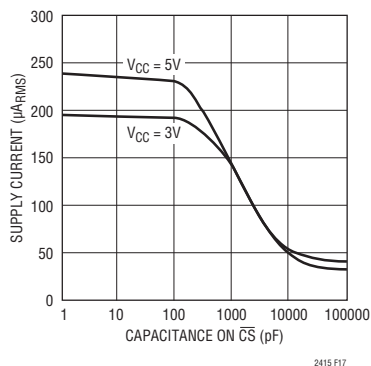

Figure 17. \overline{CS} Capacitance vs Supply Current

Timing Compatibility with the LTC2410/LTC2413

All timing modes described above are identical with respect to the LTC2410/LTC2413 and LTC2415/LTC2415-1, with one exception. The conversion time of the LTC2410 is 133ms while the conversion time of the LTC2415 is 66.6ms

and the conversion time of the LTC2413 is 146ms, while the LTC2415-1 is 73ms. In systems where the SDO pin is monitored for the end-of-conversion signal (SDO goes low once the conversion is complete) these two devices can be interchanged. In cases where SDO is not monitored, a wait state is inserted between conversions, the duration of this wait state must be greater than 66.6ms for the LTC2415, greater than 133ms for the LTC2410, greater than 146ms for the LTC2413 and greater than 73ms for the LTC2415-1.

PRESERVING THE CONVERTER ACCURACY

The LTC2415/LTC2415-1 are designed to reduce as much as possible conversion result sensitivity to device decoupling, PCB layout, anti-aliasing circuits, line frequency perturbations and so on. Nevertheless, in order to preserve the extreme accuracy capability of this part, some simple precautions are desirable.

Digital Signal Levels

The LTC2415/LTC2415-1 digital interface is easy to use. Its digital inputs (F_0 , \overline{CS} and SCK in External SCK mode of operation) accept standard TTL/CMOS logic levels and the internal hysteresis receivers can tolerate edge rates as slow as 100 μ s. However, some considerations are required to take advantage of the exceptional accuracy and low supply current of this converter.

The digital output signals (SDO and SCK in Internal SCK mode of operation) are less of a concern because they are not generally active during conversion.

While a digital input signal is in the range 0.5V to ($V_{CC} - 0.5V$), the CMOS input receiver draws additional current from the power supply. It should be noted that, when any one of the digital input signals (F_0 , \overline{CS} and SCK in External SCK mode of operation) is within this range, the LTC2415/LTC2415-1 power supply current may increase even if the signal in question is at a valid logic level. For micropower operation, it is recommended to drive all digital input signals to full CMOS levels [$V_{IL} < 0.4V$ and $V_{OH} > (V_{CC} - 0.4V)$].

During the conversion period, the undershoot and/or overshoot of a fast digital signal connected to the LTC2415/

APPLICATIONS INFORMATION

LTC2415-1 pins may severely disturb the analog to digital conversion process. Undershoot and overshoot can occur because of the impedance mismatch at the converter pin when the transition time of an external control signal is less than twice the propagation delay from the driver to LTC2415/LTC2415-1. For reference, on a regular FR-4 board, signal propagation velocity is approximately 183ps/inch for internal traces and 170ps/inch for surface traces. Thus, a driver generating a control signal with a minimum transition time of 1ns must be connected to the converter pin through a trace shorter than 2.5 inches. This problem becomes particularly difficult when shared control lines are used and multiple reflections may occur. The solution is to carefully terminate all transmission lines close to their characteristic impedance.

Parallel termination near the LTC2415/LTC2415-1 pins will eliminate this problem but will increase the driver power dissipation. A series resistor between 27 Ω and 56 Ω placed near the driver or near the LTC2415/LTC2415-1 pins will also eliminate this problem without additional power dissipation. The actual resistor value depends upon the trace impedance and connection topology.

An alternate solution is to reduce the edge rate of the control signals. It should be noted that using very slow edges will increase the converter power supply current during the transition time. The multiple ground pins used in this package configuration, as well as the differential input and reference architecture, reduce substantially the converter's sensitivity to ground currents.

Particular attention must be given to the connection of the F_0 signal when the LTC2415/LTC2415-1 are used with an external conversion clock. This clock is active during the conversion time and the normal mode rejection provided by the internal digital filter is not very high at this frequency. A normal mode signal of this frequency at the converter reference terminals may result into DC gain and INL errors. A normal mode signal of this frequency at the converter input terminals may result into a DC offset error. Such perturbations may occur due to asymmetric capacitive coupling between the F_0 signal trace and the converter input and/or reference connection traces. An immediate solution is to maintain maximum possible separation between the F_0 signal trace and the input/ref-

erence signals. When the F_0 signal is parallel terminated near the converter, substantial AC current is flowing in the loop formed by the F_0 connection trace, the termination and the ground return path. Thus, perturbation signals may be inductively coupled into the converter input and/or reference. In this situation, the user must reduce to a minimum the loop area for the F_0 signal as well as the loop area for the differential input and reference connections.

Driving the Input and Reference

The input and reference pins of the LTC2415/LTC2415-1 converters are directly connected to a network of sampling capacitors. Depending upon the relation between the differential input voltage and the differential reference voltage, these capacitors are switching between these four pins transferring small amounts of charge in the process. A simplified equivalent circuit is shown in Figure 18.

For a simple approximation, the source impedance R_S driving an analog input pin (IN^+ , IN^- , REF^+ or REF^-) can be considered to form, together with R_{SW} and C_{EQ} (see Figure 18), a first order passive network with a time constant $\tau = (R_S + R_{SW}) \cdot C_{EQ}$. The converter is able to sample the input signal with better than 1ppm accuracy if the sampling period is at least 14 times greater than the input circuit time constant τ . The sampling process on the four input analog pins is quasi-independent so each time constant should be considered by itself and, under worst-case circumstances, the errors may add.

When using the internal oscillator ($F_0 = \text{LOW}$ or HIGH), the LTC2415's front-end switched-capacitor network is clocked at 76800Hz corresponding to a 13 μs sampling period and the LTC2415-1's front end is clocked at 69900Hz corresponding to 14.2 μs . Thus, for settling errors of less than 1ppm, the driving source impedance should be chosen such that $\tau \leq 13\mu\text{s}/14 = 920\text{ns}$ (LTC2415) and $\tau < 14.2\mu\text{s}/14 = 1.01\mu\text{s}$ (LTC2415-1). When an external oscillator of frequency f_{EOSC} is used, the sampling period is $2/f_{EOSC}$ and, for a settling error of less than 1ppm, $\tau \leq 0.14/f_{EOSC}$.

Input Current

If complete settling occurs on the input, conversion results will be unaffected by the dynamic input current. An

APPLICATIONS INFORMATION

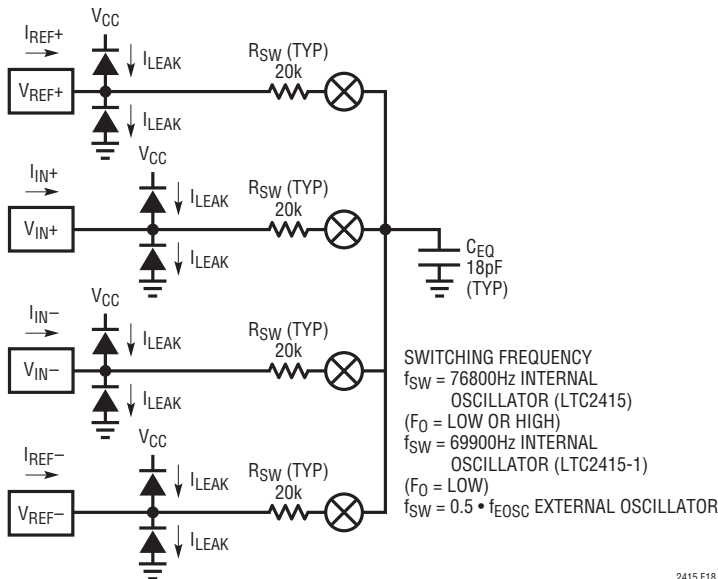

2415 F18

Figure 18. LTC2415/LTC2415-1 Equivalent Analog Input Circuit

$$I(\text{IN}^+)_{\text{AVG}} = \frac{V_{\text{IN}} + V_{\text{INCM}} - V_{\text{REFCM}}}{0.5 \cdot R_{\text{EQ}}}$$

$$I(\text{IN}^-)_{\text{AVG}} = \frac{-V_{\text{IN}} + V_{\text{INCM}} - V_{\text{REFCM}}}{0.5 \cdot R_{\text{EQ}}}$$

$$I(\text{REF}^+)_{\text{AVG}} = \frac{1.5 \cdot V_{\text{REF}} - V_{\text{INCM}} + V_{\text{REFCM}}}{0.5 \cdot R_{\text{EQ}}} - \frac{V_{\text{IN}}^2}{V_{\text{REF}} \cdot R_{\text{EQ}}}$$

$$I(\text{REF}^-)_{\text{AVG}} = \frac{-1.5 \cdot V_{\text{REF}} - V_{\text{INCM}} + V_{\text{REFCM}}}{0.5 \cdot R_{\text{EQ}}} + \frac{V_{\text{IN}}^2}{V_{\text{REF}} \cdot R_{\text{EQ}}}$$

where:

$$V_{\text{REF}} = \text{REF}^+ - \text{REF}^-$$

$$V_{\text{REFCM}} = \left(\frac{\text{REF}^+ + \text{REF}^-}{2} \right)$$

$$V_{\text{IN}} = \text{IN}^+ - \text{IN}^-$$

$$V_{\text{INCM}} = \left(\frac{\text{IN}^+ + \text{IN}^-}{2} \right)$$

$$R_{\text{EQ}} = 3.61\text{M}\Omega \text{ INTERNAL OSCILLATOR } 60\text{Hz Notch } (F_0 = \text{LOW}) \text{ LTC2415}$$

$$R_{\text{EQ}} = 4.32\text{M}\Omega \text{ INTERNAL OSCILLATOR } 50\text{Hz Notch } (F_0 = \text{HIGH}) \text{ LTC2415}$$

$$R_{\text{EQ}} = (0.555 \cdot 10^{12}) / f_{\text{OSC}} \text{ EXTERNAL OSCILLATOR}$$

$$R_{\text{EQ}} = 3.97\text{M}\Omega \text{ INTERNAL OSCILLATOR } 50\text{Hz} / 60\text{Hz Notch } (F_0 = \text{LOW}) \text{ LTC2415-1}$$

incomplete settling of the input signal sampling process may result in gain and offset errors, but it will not degrade the INL performance of the converter. Figure 18 shows the mathematical expressions for the average bias currents flowing through the IN⁺ and IN⁻ pins as a result of the sampling charge transfers when integrated over a substantial time period (longer than 64 internal clock cycles).

The effect of this input dynamic current can be analyzed using the test circuit of Figure 19. The C_{PAR} capacitor includes the LTC2415/LTC2415-1 pin capacitance (5pF typical) plus the capacitance of the test fixture used to obtain the results shown in Figures 20 and 21. A careful implementation can bring the total input capacitance (C_{IN} + C_{PAR}) closer to 5pF thus achieving better performance than the one predicted by Figures 20 and 21. For simplicity, two distinct situations can be considered.

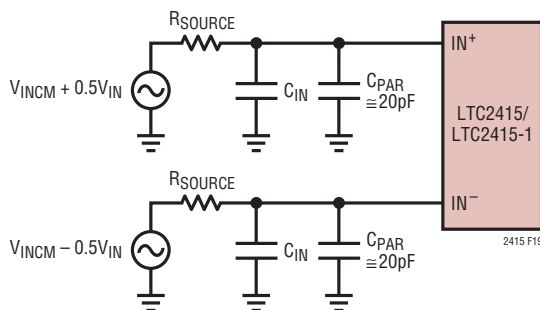

2415 F19

Figure 19. An RC Network at IN⁺ and IN⁻

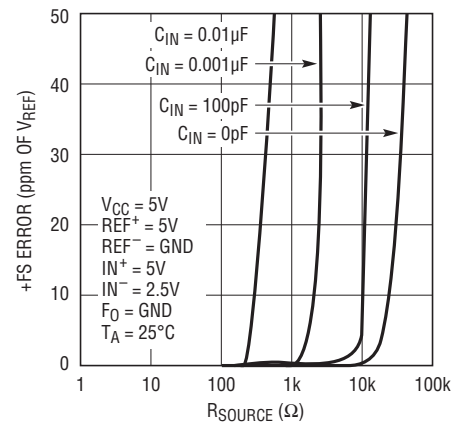

2415 F20

Figure 20. +FS Error vs R_{SOURCE} at IN⁺ or IN⁻ (Small C_{IN})

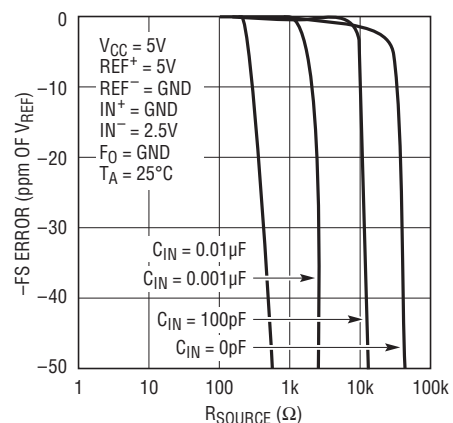

2415 F21

Figure 21. -FS Error vs R_{SOURCE} at IN⁺ or IN⁻ (Small C_{IN})

2415fa

APPLICATIONS INFORMATION

For relatively small values of input capacitance ($C_{IN} < 0.01\mu\text{F}$), the voltage on the sampling capacitor settles almost completely and relatively large values for the source impedance result in only small errors. Such values for C_{IN} will deteriorate the converter offset and gain performance without significant benefits of signal filtering and the user is advised to avoid them. Nevertheless, when small values of C_{IN} are unavoidably present as parasitics of input multiplexers, wires, connectors or sensors, the LTC2415/LTC2415-1 can maintain their exceptional accuracy while operating with relative large values of source resistance as shown in Figures 20 and 21. These measured results may be slightly different from the first order approximation suggested earlier because they include the effect of the actual second order input network together with the nonlinear settling process of the input amplifiers. For small C_{IN} values, the settling on IN^+ and IN^- occurs almost independently and there is little benefit in trying to match the source impedance for the two pins.

Larger values of input capacitors ($C_{IN} > 0.01\mu\text{F}$) may be required in certain configurations for anti-aliasing or general input signal filtering. Such capacitors will average the input sampling charge and the external source resistance will see a quasi constant input differential impedance. When $F_0 = \text{LOW}$ (internal oscillator and 60Hz notch), the typical differential input resistance is $1.8\text{M}\Omega$ (LTC2415), $1.97\text{M}\Omega$ (LTC2415-1) which will generate a gain error of approximately 0.28ppm for each ohm of source resistance driving IN^+ or IN^- . For the LTC2415, when $F_0 = \text{HIGH}$ (internal oscillator and 50Hz notch), the typical differential input resistance is $2.16\text{M}\Omega$ which will generate a gain error of approximately 0.23ppm for each ohm of source resistance driving IN^+ or IN^- . When F_0 is driven by an external oscillator with a frequency f_{EOSC} (external conversion clock operation), the typical differential input resistance is $0.28 \cdot 10^{12}/f_{EOSC}\Omega$ and each ohm of source resistance driving IN^+ or IN^- will result in $1.78 \cdot 10^{-6} \cdot f_{EOSC}\text{ppm}$ gain error. The effect of the source resistance on the two input pins is additive with respect to this gain error. The typical +FS and -FS errors as a function of the sum of the source resistance seen by IN^+ and IN^- for large values of C_{IN} are shown in Figures 22 and 23.

In addition to this gain error, an offset error term may also appear. The offset error is proportional to the mismatch between the source impedance driving the two input pins IN^+ and IN^- and with the difference between the input and reference common mode voltages. While the input drive circuit nonzero source impedance combined with the converter average input current will not degrade the INL performance, indirect distortion may result from the modulation of the offset error by the common mode component of the input signal. Thus, when using large C_{IN} capacitor values, it is advisable to carefully match the source impedance seen by the IN^+ and IN^- pins. When $F_0 = \text{LOW}$ (internal oscillator and 60Hz notch), every 1Ω mismatch in source impedance transforms a full-scale common mode input signal into a differential mode input signal of 0.28ppm. When $F_0 = \text{HIGH}$ (internal oscillator and 50Hz notch), every 1Ω mismatch in source impedance transforms a full-scale common mode input signal into a differential mode input signal of 0.23ppm. When F_0 is driven by an external oscillator with a frequency f_{EOSC} , every 1Ω mismatch in source impedance transforms a full-scale common mode input signal into a differential mode input signal of $1.78 \cdot 10^{-6} \cdot f_{EOSC}\text{ppm}$. Figure 24 shows the typical offset error due to input common mode voltage for various values of source resistance imbalance between the IN^+ and IN^- pins when large C_{IN} values are used.

If possible, it is desirable to operate with the input signal common mode voltage very close to the reference signal common mode voltage as is the case in the ratiometric measurement of a symmetric bridge. This configuration eliminates the offset error caused by mismatched source impedances.

The magnitude of the dynamic input current depends upon the size of the very stable internal sampling capacitors and upon the accuracy of the converter sampling clock. The accuracy of the internal clock over the entire temperature and power supply range is typical better than 0.5%. Such a specification can also be easily achieved by an external clock. When relatively stable resistors ($50\text{ppm}/^\circ\text{C}$) are used for the external source impedance seen by IN^+ and IN^- , the expected drift of the dynamic current, offset and gain

APPLICATIONS INFORMATION

errors will be insignificant (about 1% of their respective values over the entire temperature and voltage range). Even for the most stringent applications, a one-time calibration operation may be sufficient.

In addition to the input sampling charge, the input ESD protection diodes have a temperature dependent leakage current. This current, nominally 1nA (± 10 nA max), results in a small offset shift. A 100 Ω source resistance will create a 0.1 μ V typical and 1 μ V maximum offset voltage.

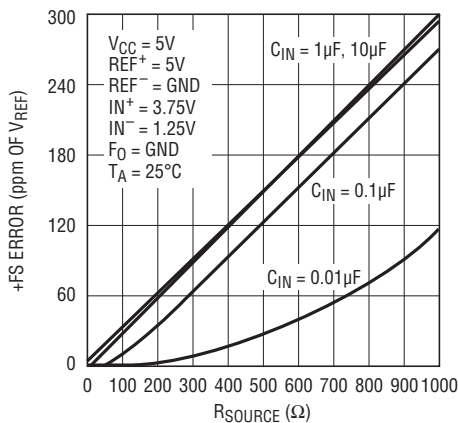

2415 F22

Figure 22. +FS Error vs R_{SOURCE} at IN^+ or IN^- (Large C_{IN})

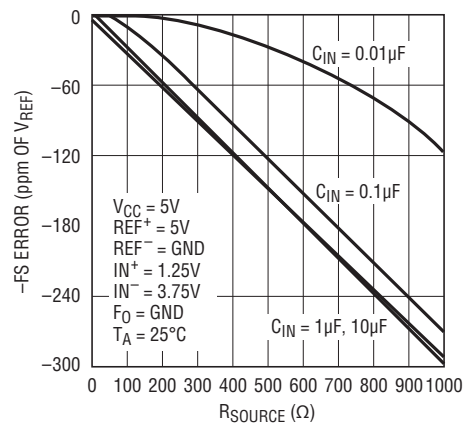

2415 F23

Figure 23. -FS Error vs R_{SOURCE} at IN^+ or IN^- (Large C_{IN})

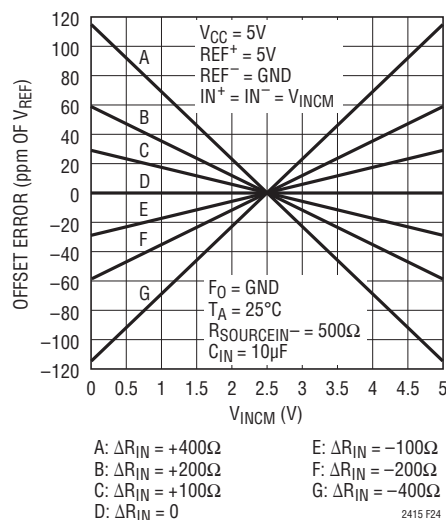

2415 F24

Figure 24. Offset Error vs Common Mode Voltage ($V_{INCM} = IN^+ = IN^-$) and Input Source Resistance Imbalance ($\Delta R_{IN} = R_{SOURCEIN^+} - R_{SOURCEIN^-}$) for Large C_{IN} Values ($C_{IN} \geq 1\mu F$)

APPLICATIONS INFORMATION

Reference Current

In a similar fashion, the LTC2415/LTC2415-1 sample the differential reference pins REF⁺ and REF⁻ transferring small amount of charge to and from the external driving circuits thus producing a dynamic reference current. This current does not change the converter offset, but it may degrade the gain and INL performance. The effect of this current can be analyzed in the same two distinct situations.

For relatively small values of the external reference capacitors ($C_{REF} < 0.01 \mu\text{F}$), the voltage on the sampling capacitor settles almost completely and relatively large values for the source impedance result in only small errors. Such values for C_{REF} will deteriorate the converter offset and gain performance without significant benefits of reference filtering and the user is advised to avoid them.

Larger values of reference capacitors ($C_{REF} > 0.01 \mu\text{F}$) may be required as reference filters in certain configurations. Such capacitors will average the reference sampling charge and the external source resistance will see a quasi constant reference differential impedance. For the LTC2415, when $F_0 = \text{LOW}$ (internal oscillator and 60Hz notch), the typical differential reference resistance is $1.3\text{M}\Omega$ which will generate a gain error of approximately 0.38ppm for each ohm of source resistance driving REF⁺ or REF⁻. When $F_0 = \text{HIGH}$ (internal oscillator and 50Hz notch), the typical differential reference resistance is $1.56\text{M}\Omega$ which will generate a gain error of approximately 0.32ppm for each ohm of source resistance driving REF⁺ or REF⁻. For the LTC2415-1, the typical differential reference resistance is $1.43\text{M}\Omega$. When F_0 is driven by an external oscillator with a frequency f_{EOSC} (external conversion clock operation), the typical differen-

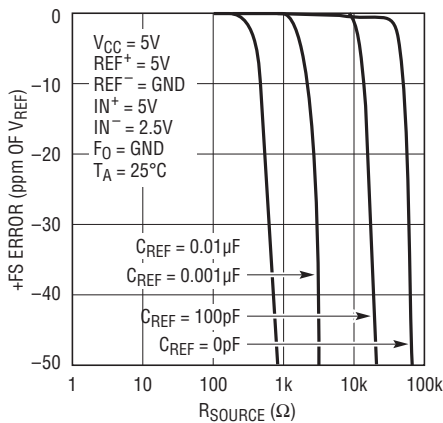

Figure 25. +FS Error vs R_{SOURCE} at REF⁺ or REF⁻ (Small C_{IN})

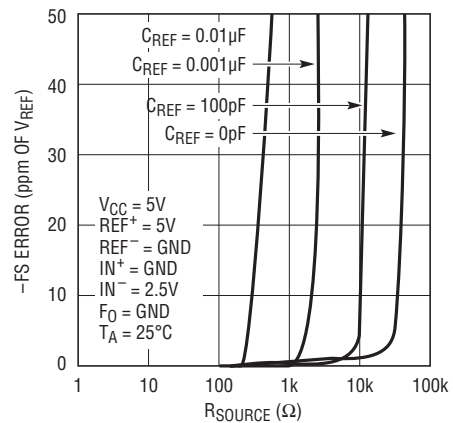

Figure 26. -FS Error vs R_{SOURCE} at REF⁺ or REF⁻ (Small C_{IN})

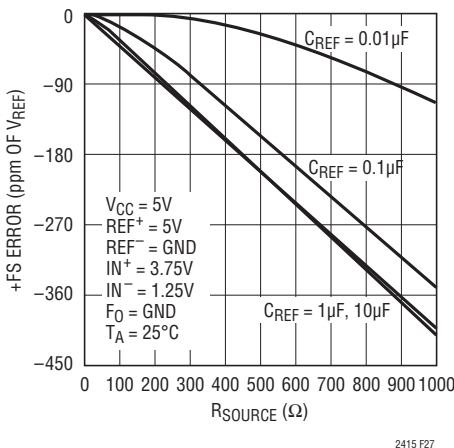

Figure 27. +FS Error vs R_{SOURCE} at REF⁺ and REF⁻ (Large C_{REF})

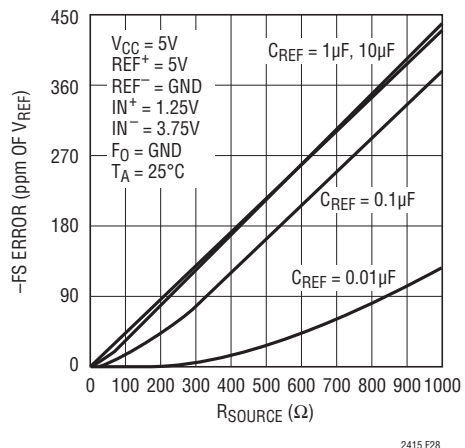

Figure 28. -FS Error vs R_{SOURCE} at REF⁺ and REF⁻ (Large C_{REF})

APPLICATIONS INFORMATION

tial reference resistance is $0.20 \cdot 10^{12}/f_{EOSC}\Omega$ and each ohm of source resistance driving REF⁺ or REF⁻ will result in $2.47 \cdot 10^{-6} \cdot f_{EOSC}$ ppm gain error. The effect of the source resistance on the two reference pins is additive with respect to this gain error. The typical +FS and -FS errors for various combinations of source resistance seen by the REF⁺ and REF⁻ pins and external capacitance C_{REF} connected to these pins are shown in Figures 25, 26, 27 and 28.

In addition to this gain error, the converter INL performance is degraded by the reference source impedance. When F₀ = LOW (internal oscillator and 60Hz notch), every 100Ω of source resistance driving REF⁺ or REF⁻ translates into about 1.34ppm additional INL error. For the LTC2415, when F₀ = HIGH (internal oscillator and 50Hz notch), every 100Ω of source resistance driving REF⁺ or REF⁻ translates into about 1.1ppm additional INL error; and for the LTC2415-1 operating with simultaneous 50Hz/60Hz rejection, every 100Ω of source resistance leads to an additional 1.22ppm of additional INL error. When F₀ is driven by an external oscillator with a frequency f_{EOSC}, every 100Ω of source resistance driving REF⁺ or REF⁻ translates into about $8.73 \cdot 10^{-6} \cdot f_{EOSC}$ ppm additional INL error. Figure 26 shows the typical INL error due to the source resistance driving the REF⁺ or REF⁻ pins when large C_{REF} values are used. The

effect of the source resistance on the two reference pins is additive with respect to this INL error. In general, matching of source impedance for the REF⁺ and REF⁻ pins does not help the gain or the INL error. The user is thus advised to minimize the combined source impedance driving the REF⁺ and REF⁻ pins rather than to try to match it.

The magnitude of the dynamic reference current depends upon the size of the very stable internal sampling capacitors and upon the accuracy of the converter sampling clock. The accuracy of the internal clock over the entire temperature and power supply range is typical better than 0.5%. Such a specification can also be easily achieved by an external clock. When relatively stable resistors (50ppm/°C) are used for the external source impedance seen by REF⁺ and REF⁻, the expected drift of the dynamic current gain error will be insignificant (about 1% of its value over the entire temperature and voltage range). Even for the most stringent applications a one-time calibration operation may be sufficient.

In addition to the reference sampling charge, the reference pins ESD protection diodes have a temperature dependent leakage current. This leakage current, nominally 1nA (±10nA max), results in a small gain error. A 100Ω source resistance will create a 0.05μV typical and 0.5μV maximum full-scale error.

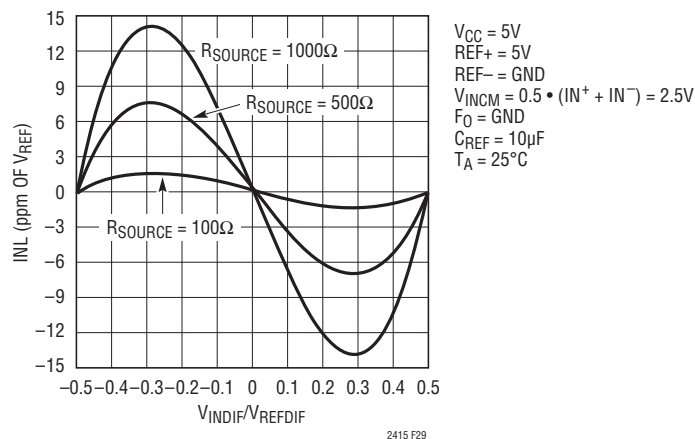

Figure 29. INL vs Differential Input Voltage ($V_{IN} = IN^+ - IN^-$) and Reference Source Resistance (R_{SOURCE} at REF⁺ and REF⁻ for Large C_{REF} Values (C_{REF} ≥ 1μF)

2415fa

APPLICATIONS INFORMATION

Normal Mode Rejection, Output Rate and Running Averages

The LTC2415/LTC2415-1 both contain an identical Sinc⁴ digital filter (see Figures 30 and 31) which offers excellent line frequency noise rejection. For the LTC2415, a notch frequency of either 50Hz or 60Hz (see Figure 32) is user selectable by tying pin F₀ high or low, respectively. On the other hand, the LTC2415-1 offers simultaneous rejection of 50Hz and 60Hz by tying F₀ low. This sets the notch frequency to approximately 55Hz (see Figure 32).

At a notch frequency of 55Hz, the LTC2415-1 rejects 50Hz ±2% and 60Hz ±2% better than 72dB. In order to achieve better than 87dB rejection of both 50Hz and 60Hz ±2%,

a running average can be performed. By averaging two consecutive ADC readings, a Sinc¹ notch is combined with the Sinc⁴ digital filter yielding the frequency response shown in Figures 33 and 34. In order to preserve the 2× output rate, adjacent results are averaged with the following algorithm:

Result 1 = average (sample 0, sample 1)

Result 2 = average (sample 1, sample 2)

Result 3 = average (sample 2, sample 3)

...

Result N = average (sample n-1, sample n)

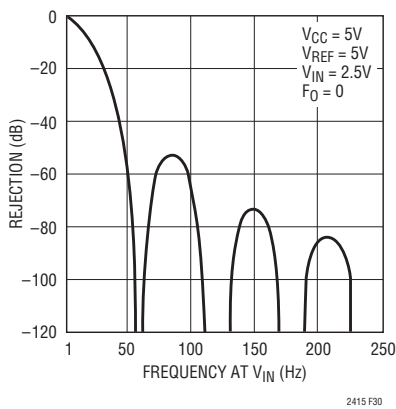

Figure 30. Rejection vs Frequency at V_{IN}

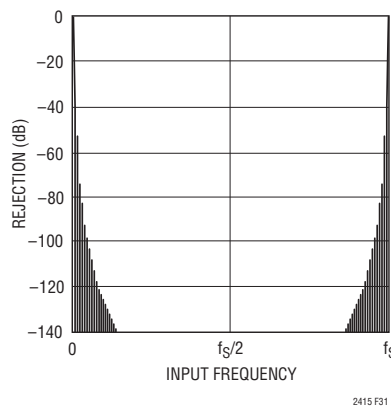

Figure 31. Rejection vs Frequency at V_{IN}

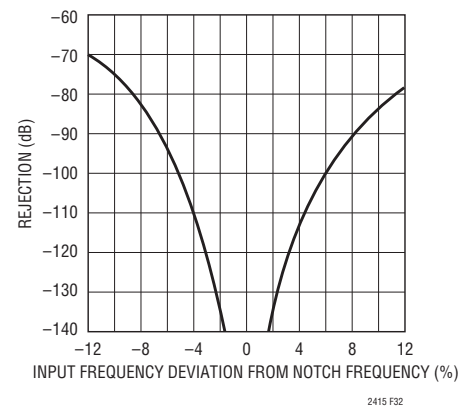

Figure 32. Rejection vs Frequency at V_{IN}

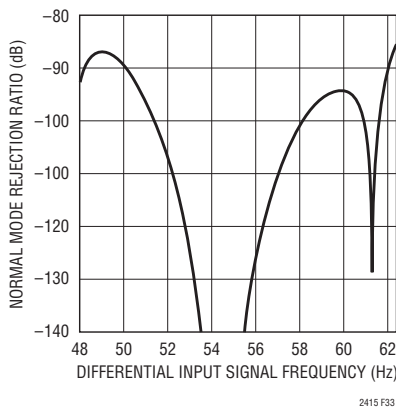

Figure 33. Normal Mode Rejection when Using an Internal Oscillator

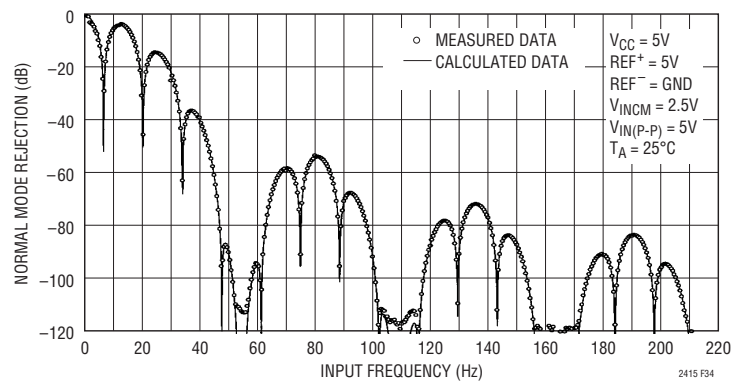

Figure 34. Input Normal Mode Rejection vs Input Frequency with Input Perturbation of 100% of Full Scale

APPLICATIONS INFORMATION

Sample Driver for LTC2415/LTC2415-1 SPI Interface

Figure 35 shows the use of an LTC2415/LTC2415-1 with a differential multiplexer. This is an inexpensive multiplexer that will contribute some error due to leakage if used directly with the output from the bridge, or if resistors are inserted as a protection mechanism from overvoltage. Although the bridge output may be within the input range of the A/D and multiplexer in normal operation, some thought should be given to fault conditions that could result in full excitation voltage at the inputs to the multiplexer or ADC. The use of amplification prior to the multiplexer will largely eliminate errors associated with channel leakage developing error voltages in the source impedance.

The LTC2415/LTC2415-1 have a very simple serial interface that makes interfacing to microprocessors and microcontrollers very easy.

The listing in Figure 38 is a simple assembler routine for the 68HC11 microcontroller. It uses PORT D, configuring it for SPI data transfer between the controller and the LTC2415/LTC2415-1. Figure 36 shows the simple 3-wire SPI connection.

The code begins by declaring variables and allocating four memory locations to store the 32-bit conversion result. This is followed by initializing PORT D's SPI configuration. The program then enters the main sequence. It activates the LTC2415/LTC2415-1 serial interface by setting the \overline{SS} output low, sending a logic low to \overline{CS} . It next waits in a loop for a logic low on the data line, signifying end-of-conversion. After the loop is satisfied, four SPI transfers are completed, retrieving the conversion. The main sequence ends by setting \overline{SS} high. This places the LTC2415/LTC2415-1 serial interface in a high impedance state and initiates another conversion.

The performance of the LTC2415/LTC2415-1 can be verified using the demonstration board DC291A, see Figure 40 for the schematic. This circuit uses the computer's serial port to generate power and the SPI digital signals necessary for starting a conversion and reading the result. It includes a Labview application software program (see Figure 39) which graphically captures the conversion results. It can be used to determine noise performance, stability and with an external source, linearity. As exemplified in the schematic, the LTC2415/LTC2415-1 are extremely easy to use. This demonstration board and associated software is available by contacting Linear Technology.

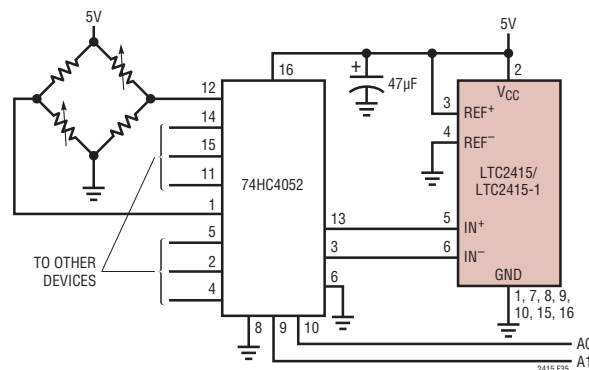

Figure 35. Use a Differential Multiplexer to Expand Channel Capability

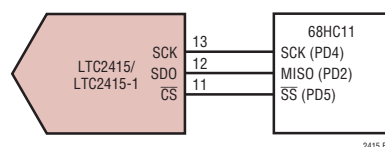

Figure 36. Connecting the LTC2415/LTC2415-1 to a 68HC11 MCU Using the SPI Serial Interface

APPLICATIONS INFORMATION

Correlated Double Sampling with the LTC2415/LTC2415-1

Figure 37 shows the LTC2415/LTC2415-1 in a correlated double sampling circuit that achieves a noise floor of under 100nV. In this scheme, the polarity of the bridge is alternated every other sample and the result is the average of a pair of samples of opposite sign. This technique has the benefit of canceling any fixed DC error components in the bridge, amplifiers and the converter, as these will alternate in polarity relative to the signal. Offset voltages and currents, thermocouple voltages at junctions of dissimilar metals and the lower frequency components of 1/f noise are virtually eliminated.

The LTC2415/LTC2415-1 have the virtue of being able to digitize an input voltage that is outside the range defined by the reference, thereby providing a simple means to implement a ratiometric example of correlated double sampling.

This circuit uses a bipolar amplifier (LT1219—U1 and U2) that has neither the lowest noise nor the highest gain. It does, however, have an output stage that can effectively suppress the conversion spikes from the LTC2415/LTC2415-1. The LT1219 is a C-Load™ stable amplifier that, by design, needs at least 0.1 μF output capacitance to remain stable. The 0.1 μF ceramic capacitors at the outputs (C1 and C2) should be placed and routed to minimize lead inductance or their effectiveness in preventing envelope detection in the input stage will be reduced. Alternatively, several smaller capacitors could be placed so that lead inductance is further reduced. This is a consideration because the frequency content of the conversion spikes extends to 50MHz or more. The output impedance of most op amps increases dramatically with frequency but the effective output impedance of the LT1219 remains low, determined by the ESR and inductance of the capacitors

above 10MHz. The conversion spikes that remain at the output of other bipolar amplifiers pass through the feedback network and often overdrive the input of the amplifier, producing envelope detection. RFI may also be present on the signal lines from the bridge; C3 and C4 provide RFI suppression at the signal input, as well as suppressing transient voltages during bridge commutation.

The wideband noise density of the LT1219 is $33\text{nV}\sqrt{\text{Hz}}$, seemingly much noisier than the lowest noise amplifiers. However, in the region just below the 1/f corner that is not well suppressed by the correlated double sampling, the average noise density is similar to the noise density of many low noise amplifiers. If the amplifier is rolled off below about 1500Hz, the total noise bandwidth is determined by the converter's Sinc^4 filter at about 12Hz. The use of correlated double sampling involves averaging even numbers of samples; hence, in this situation, two samples would be averaged to give an input-referred noise level of about $100\text{nV}_{\text{RMS}}$.

Level shift transistors Q4 and Q5 are included to allow excitation voltages up to the maximum recommended for the bridge. In the case shown, if a 10V supply is used, the excitation voltage to the bridge is 8.5V and the outputs of the bridge are above the supply rail of the ADC. U1 and U2 are also used to produce a level shift to bring the outputs within the input range of the converter. This instrumentation amplifier topology does not require well-matched resistors in order to produce good CMRR. However, the use of R2 requires that R3 and R6 match well, as the common mode gain is approximately -12dB . If the bridge is composed of four equal 350Ω resistors, the differential component associated with mismatch of R3 and R6 is nearly constant with either polarity of excitation and, as with offset, its contribution is canceled.

APPLICATIONS INFORMATION

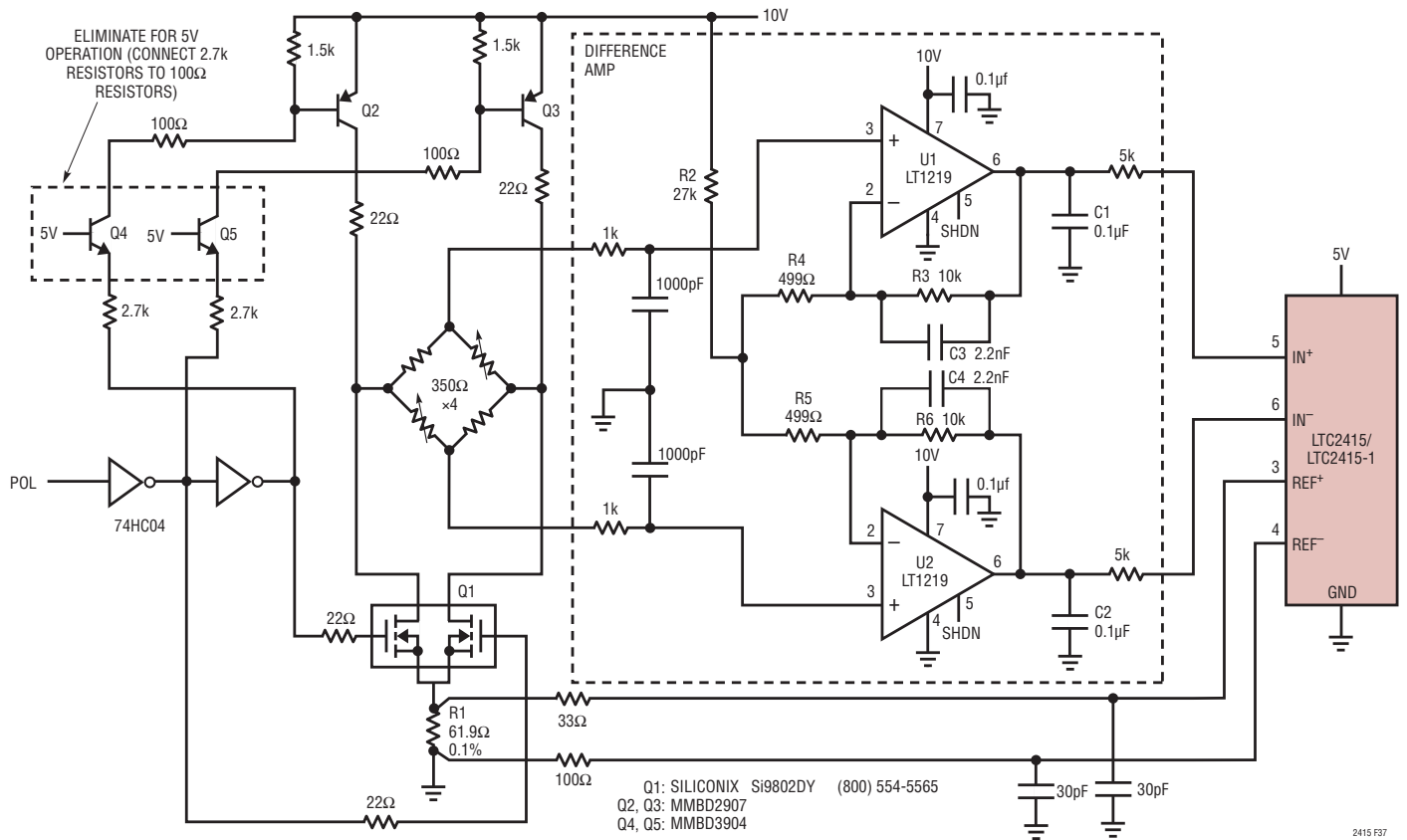

Figure 37. Correlated Double Sampling Resolves 100nV

LTC2415/LTC2415-1

TYPICAL APPLICATIONS

```
*****
* This example program transfers the LTC2415/LTC2415-1 32-bit output *
* conversion result into four consecutive 8-bit memory locations. *
*****
*68HC11 register definition
PORTD EQU    $1008 Port D data register
*           " - , - , SS* , CSK ; MOSI, MISO, TxD , RxD"
DDRD  EQU    $1009 Port D data direction register
SPSR  EQU    $1028 SPI control register
*           "SPIE, SPE , DWOM, MSTR; SPOL, CPHA, SPR1, SPRO"
SPSR  EQU    $1029 SPI status register
*           "SPIF, WCOL, - , MODF; - , - , - , - "
SPDR  EQU    $102A SPI data register; Read-Buffer; Write-Shifter
*
* RAM variables to hold the LTC2415/LTC2415-1's 32 conversion result
*
DIN1  EQU    $00   This memory location holds the LTC2415/LTC2415-1's bits 31 - 24
DIN2  EQU    $01   This memory location holds the LTC2415/LTC2415-1's bits 23 - 16
DIN3  EQU    $02   This memory location holds the LTC2415/LTC2415-1's bits 15 - 08
DIN4  EQU    $03   This memory location holds the LTC2415/LTC2415-1's bits 07 - 00
*
*****
* Start GETDATA Routine *
*****
*
  ORG $C000 Program start location
INIT1 LDS    #$CFFF Top of C page RAM, beginning location of stack
  LDAA #$2F  -, -, 1, 0; 1, 1, 1, 1
*
  STAA PORTD Keeps SS* a logic high when DDRD, bit 5 is set
  LDAA #$38  -, -, 1, 1; 1, 0, 0, 0
  STAA DDRD  SS*, SCK, MOSI are configured as Outputs
*           MISO, TxD, RxD are configured as Inputs
*DDRDR's bit 5 is a 1 so that port D's SS* pin is a general output
  LDAA #$50
  STAA SPCR  The SPI is configured as Master, CPHA = 0, CPOL = 0
*           and the clock rate is E/2
*           (This assumes an E-Clock frequency of 4MHz. For higher E-
*           Clock frequencies, change the above value of $50 to a value
*           that ensures the SCK frequency is 2MHz or less.)
GETDATA    PSHX
  PSHY
  PSHA
  LDX #$0   The X register is used as a pointer to the memory locations
*           that hold the conversion data
  LDY #$1000
  BCLR PORTD, Y %00100000 This sets the SS* output bit to a logic
*                           low, selecting the LTC2415/LTC2415-1
*
```

TYPICAL APPLICATIONS

```

*****
* The next short loop waits for the
* LTC2415/LTC2415-1's conversion to finish before
* starting the SPI data transfer
*****
*
CONVEND    LDAA    PORTD    Retrieve the contents of port D
          ANDA#%00000100    Look at bit 2
*          Bit 2 = Hi; the LTC2415/LTC2415-1's conversion is not
*          complete
*          Bit 2 = Lo; the LTC2415/LTC2415-1's conversion is complete
          BNE CONVEND      Branch to the loop's beginning while bit 2 remains
                          high
*
*
*****
* The SPI data transfer
*****
*
TRFLP1 LDAA    #$0    Load accumulator A with a null byte for SPI transfer
          STAA SPDR    This writes the byte in the SPI data register and starts
*          the transfer
WAIT1  LDAA    SPSR    This loop waits for the SPI to complete a serial
          BPL WAIT1    The SPIF (SPI transfer complete flag) bit is the SPSR's MSB
*          and is set to one at the end of an SPI transfer. The branch
*          will occur while SPIF is a zero.
          LDAASPCR    Load accumulator A with the current byte of LTC2415/LTC2415-1 data
          that was just received
          STAA 0,X    Transfer the LTC2415/LTC2415-1's data to memory
          INX        Increment the pointer
          CPX #DIN4+1    Has the last byte been transferred/exchanged?
          BNE TRFLP1    If the last byte has not been reached, then proceed to the
*          next byte for transfer/exchange
*          BSET PORTD,Y %00100000 This sets the SS* output bit to a logic high,
          de-selecting the LTC2415/LTC2415-1
          PULA        Restore the A register
          PULY        Restore the Y register
          PULX        Restore the X register
          RTS

```

Figure 38. This is an Example of 68HC11 Code That Captures the LTC2415/LTC2415-1 Conversion Results Over the SPI Serial Interface Shown in Figure 40

TYPICAL APPLICATIONS

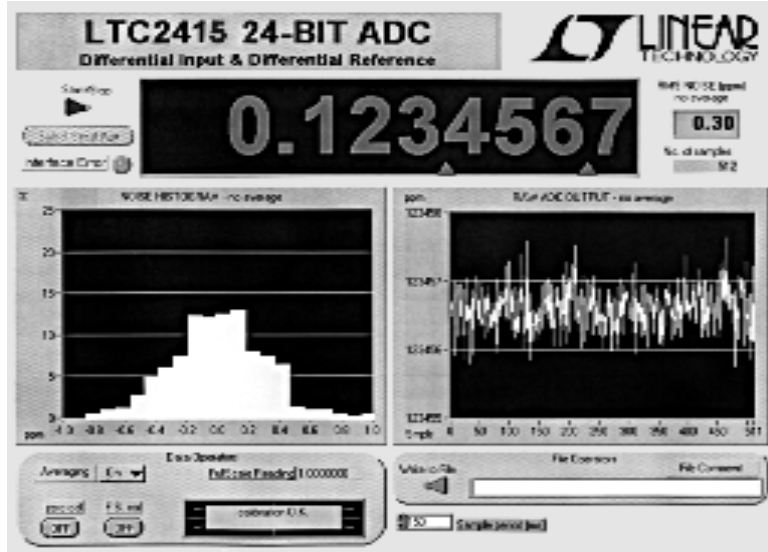
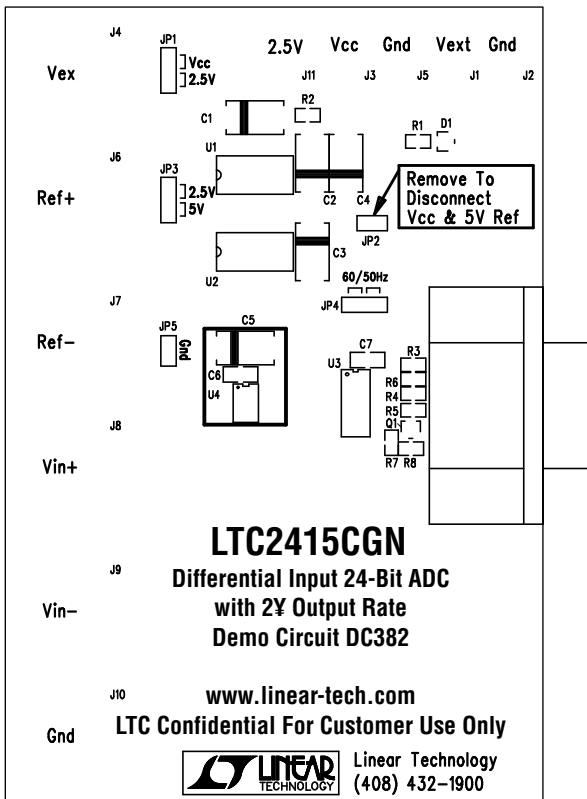
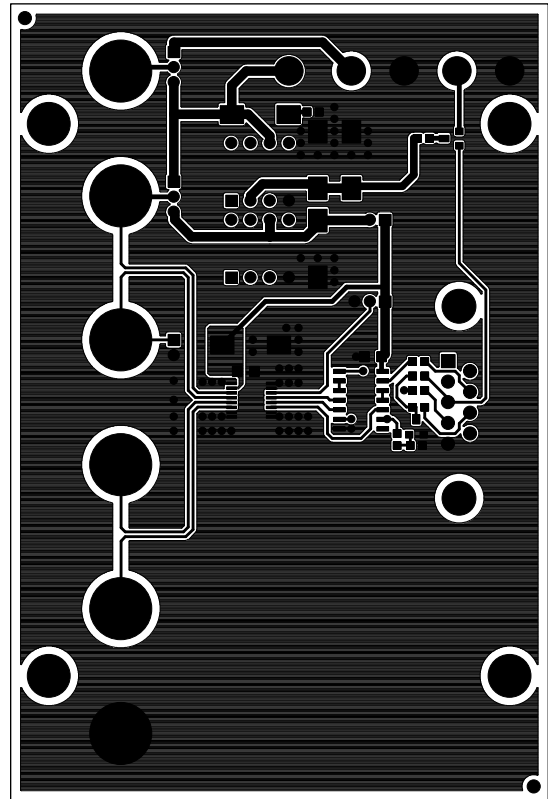

Figure 39. Display Graphic

PCB LAYOUT AND FILM



Silkscreen Top



Top Layer

PCB LAYOUT AND FILM

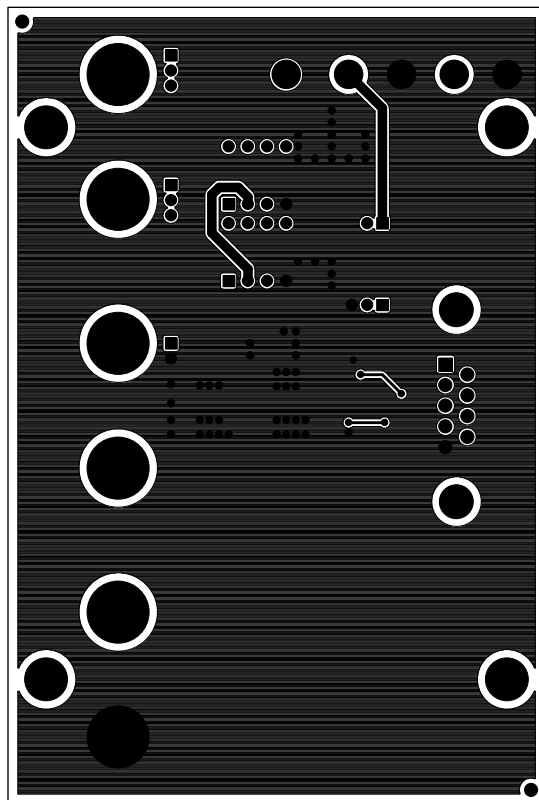

Bottom Layer

PACKAGE DESCRIPTION

Please refer to <http://www.linear.com/designtools/packaging/> for the most recent package drawings.

GN Package 16-Lead Plastic SSOP (Narrow .150 Inch) (Reference LTC DWG # 05-08-1641 Rev B)

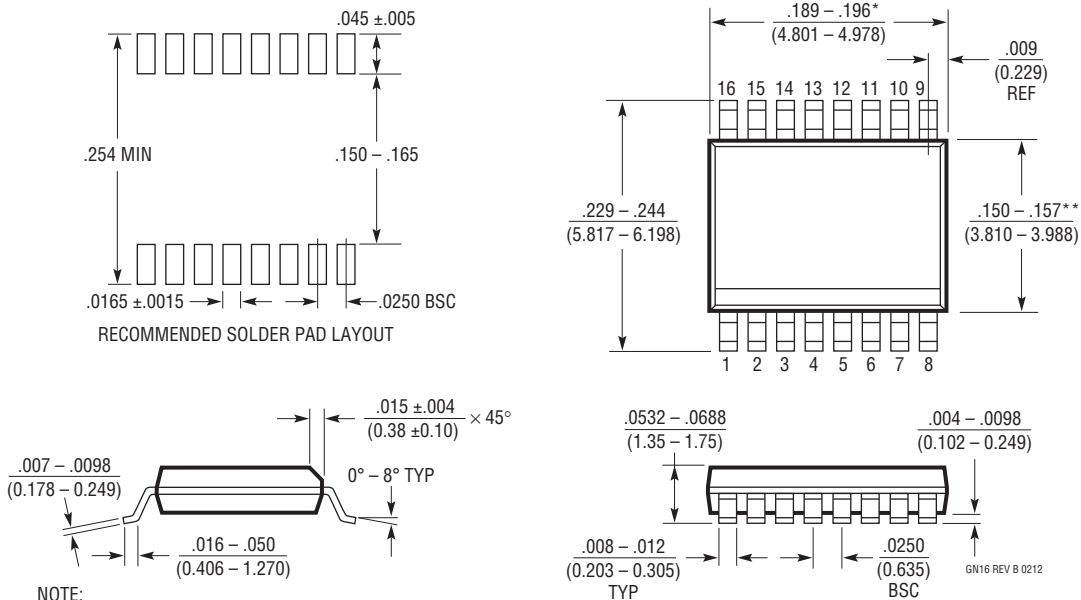

NOTE:

1. CONTROLLING DIMENSION: INCHES
2. DIMENSIONS ARE IN $\frac{\text{INCHES}}{\text{MILLIMETERS}}$
3. DRAWING NOT TO SCALE
4. PIN 1 CAN BE BEVEL EDGE OR A DIMPLE

*DIMENSION DOES NOT INCLUDE MOLD FLASH. MOLD FLASH SHALL NOT EXCEED 0.006" (0.152mm) PER SIDE

**DIMENSION DOES NOT INCLUDE INTERLEAD FLASH. INTERLEAD FLASH SHALL NOT EXCEED 0.010" (0.254mm) PER SIDE

REVISION HISTORY

REV	DATE	DESCRIPTION	PAGE NUMBER
A	08/15	Reduced external oscillator maximum frequency to 500kHz. Removed noise histogram plots for 105Hz output rate. Adjusted output data rate on G27 to maximum of 50 readings/second.	5 6, 7 9

LTC2415/LTC2415-1

TYPICAL APPLICATION

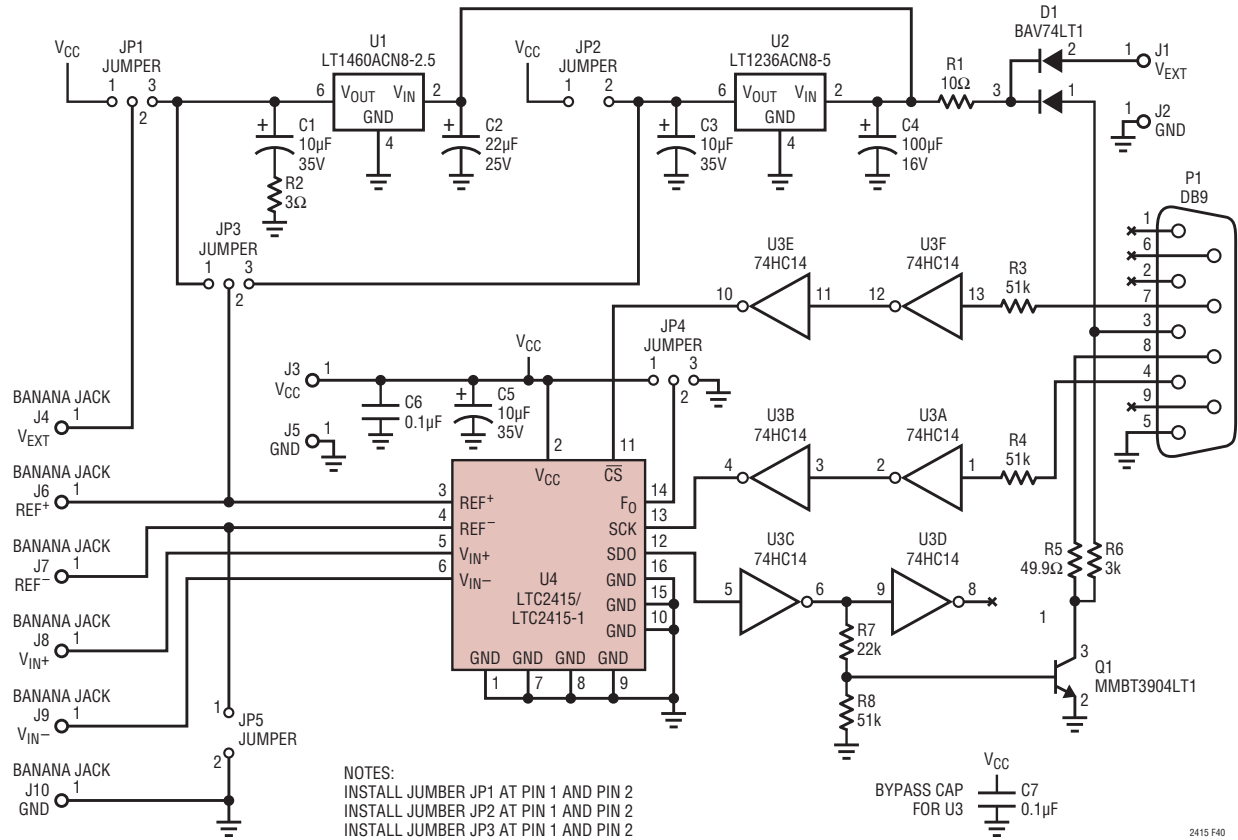

Figure 40. 24-Bit A/D Demo Board Schematic

RELATED PARTS

PART NUMBER	DESCRIPTION	COMMENTS
LT1019	Precision Bandgap Reference, 2.5V, 5V	3ppm/°C Drift, 0.05% Max Initial Accuracy
LT1025	Micropower Thermocouple Cold Junction Compensator	80 μ A Supply Current, 0.5°C Initial Accuracy
LTC1043	Dual Precision Instrumentation Switched Capacitor Building Block	Precise Charge, Balanced Switching, Low Power
LTC1050	Precision Chopper Stabilized Op Amp	No External Components 5 μ V Offset, 1.6 μ V _{p-p} Noise
LT1236A-5	Precision Bandgap Reference, 5V	0.05% Max Initial Accuracy, 5ppm/°C Drift
LT1460	Micropower Series Reference	0.075% Max Initial Accuracy, 10ppm/°C Max Drift,
LTC2400	24-Bit, No Latency $\Delta\Sigma$ ADC in SO-8	0.3ppm Noise, 4ppm INL, 10ppm Total Unadjusted Error, 200 μ A
LTC2401/LTC2402	1-/2-Channel, 24-Bit, No Latency $\Delta\Sigma$ ADCs in MSOP	0.6ppm Noise, 4ppm INL, 10ppm Total Unadjusted Error, 200 μ A
LTC2414/LTC2418	4-/8-Channel, 24-Bit, No Latency $\Delta\Sigma$ ADCs with Differential Inputs	0.3ppm Noise, 4ppm INL, 10ppm Total Unadjusted Error, 200 μ A
LTC2410	24-Bit, No Latency $\Delta\Sigma$ ADC with Differential Inputs	800nV _{RMS} Noise, Pin Compatible with LTC2415
LTC2411	24-Bit, No Latency $\Delta\Sigma$ ADC with Differential Inputs in MSOP	1.45 μ V _{RMS} Noise, 4ppm INL
LTC2413	24-Bit, No Latency $\Delta\Sigma$ ADC with Differential Inputs	Simultaneous 50Hz/60Hz Rejection, 800nV _{RMS} Noise
LTC2420	20-Bit, No Latency $\Delta\Sigma$ ADC in SO-8	1.2ppm Noise, 8ppm INL, Pin Compatible with LTC2400

Looking for pricing, stock, or lifecycle information?

Click below to explore more details on WIN SOURCE:

- ⊖ [View LTC2415IGN#PBF on WIN SOURCE](#)
- ⊖ [Analog Devices Inc. Information](#)

Optimize Your Supply Chain with WIN SOURCE Solutions

- ✓ Global Sourcing Solution
- ✓ Obsolete Management
- ✓ Cost Control Management
- ✓ Shortage Management
- ✓ Alternative Solution
- ✓ Excess Inventory Management