



THE DATASHEET OF DAC8574IPWR



 This integrated circuit can be damaged by ESD. Texas Instruments recommends that all integrated circuits be handled with appropriate precautions. Failure to observe proper handling and installation procedures can cause damage.

ESD damage can range from subtle performance degradation to complete device failure. Precision integrated circuits may be more susceptible to damage because very small parametric changes could cause the device not to meet its published specifications.

PACKAGE/ORDERING INFORMATION

PRODUCT	PACKAGE	PACKAGE DRAWING NUMBER	SPECIFICATION TEMPERATURE RANGE	PACKAGE MARKING	ORDERING NUMBER	TRANSPORT MEDIA
DAC8574	16-TSSOP	PW	–40°C TO +105°C	D8574I	DAC8574IPW	90 Piece Tube
					DAC8574IPWR	2000 Piece Tape and Reel

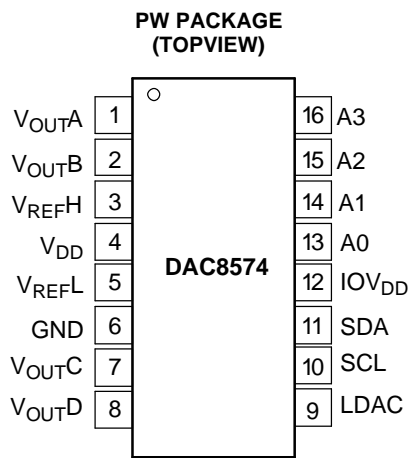

PIN DESCRIPTIONS

PIN	NAME	DESCRIPTION
1	V _{OUTA}	Analog output voltage from DAC A
2	V _{OUTB}	Analog output voltage from DAC B
3	V _{REFH}	Positive reference voltage input
4	V _{DD}	Analog voltage supply input
5	V _{REFL}	Negative reference voltage input
6	GND	Ground reference point for all circuitry on the part
7	V _{OUTC}	Analog output voltage from DAC C
8	V _{OUTD}	Analog output voltage from DAC D
9	LDAC	H/W synchronous V _{OUT} update
10	SCL	Serial clock input
11	SDA	Serial data input
12	IOV _{DD}	I/O voltage supply input
13	A0	Device address select - I ² C
14	A1	Device address select - I ² C
15	A2	Device address select - Extended
16	A3	Device address select - Extended

ABSOLUTE MAXIMUM RATINGS⁽¹⁾

V _{DD} to GND	-0.3 V to +6 V
Digital input voltage to GND	-0.3 V to V _{DD} + 0.3 V
V _{OUT} to GND	0.3 V to V _{DD} + 0.3 V
Operating temperature range	40°C to +105°C
Storage temperature range	65°C to +150°C
Junction temperature range (T _J max)	+150°C
Power dissipation: Thermal impedance (θJA)	118°C/W
Thermal impedance (θJC)	29°C/W
Lead temperature, soldering: Vapor phase (60s)	215°C
Infrared (15s)	220°C

(1) Stresses above those listed under Absolute Maximum Ratings may cause permanent damage to the device. Exposure to absolute maximum conditions for extended periods may affect device reliability.

ELECTRICAL CHARACTERISTICS
 $V_{DD} = 2.7\text{ V to }5.5\text{ V}$, $R_L = 2\text{ k}\Omega\text{ to GND}$; $C_L = 200\text{ pF to GND}$; all specifications $-40^\circ\text{C to }+105^\circ\text{C}$, unless otherwise specified.

PARAMETER	TEST CONDITIONS	MIN	TYP	MAX	UNITS
STATIC PERFORMANCE⁽¹⁾⁽²⁾					
Resolution		16			Bits
Relative accuracy				± 0.0987	% of FSR
Differential nonlinearity	Specified monotonic by design			± 1	LSB
Zero-scale error			5	20	mV
Full-scale error			-0.15	± 1.0	% of FSR
Gain error				± 1.0	% of FSR
Zero code error drift			± 7		$\mu\text{V}/^\circ\text{C}$
Gain temperature coefficient			± 3		ppm of FSR/ $^\circ\text{C}$
PSRR	$V_{DD} = 5\text{ V}$		0.75		mV/V
OUTPUT CHARACTERISTICS⁽³⁾					
Output voltage range		0		V_{REFH}	V
Output voltage settling time (full scale)	$R_L = 2\text{ k}\Omega$; $0\text{ pF} < C_L < 200\text{ pF}$		8	10	μs
	$R_L = 2\text{ k}\Omega$; $C_L = 500\text{ pF}$		12		μs
Slew rate			1		V/ μs
DC crosstalk			0.25		LSB
AC crosstalk	1 kHz Sine Wave		-100	-96	dB
Capacitive load stability	$R_L = \infty$		470		pF
	$R_L = 2\text{ k}\Omega$		1000		pF
Digital-to-analog glitch impulse	1 LSB change around major carry		20		nV-s
Digital feedthrough			0.5		nV-s
DC output impedance			1		Ω
Short-circuit current	$V_{DD} = 5\text{ V}$		50		mA
	$V_{DD} = 3\text{ V}$		20		mA
Power-up time	Coming out of power-down mode, $V_{DD} = +5\text{ V}$		2.5		μs
	Coming out of power-down mode, $V_{DD} = +3\text{ V}$		5		μs
REFERENCE INPUT					
V_{REFH} Input range		0		V_{DD}	V
V_{REFL} Input range	$V_{REFL} < V_{REFH}$	0	GND	V_{DD}	V
Reference input impedance			35		k Ω
Reference current	$V_{REF} = V_{DD} = +5\text{ V}$		135	180	μA
	$V_{REF} = V_{DD} = +3\text{ V}$		80	120	μA
LOGIC INPUTS⁽³⁾					
Input current				± 1	μA
V_{IN_L} , Input low voltage				$0.3 \times IOV_{DD}$	V
V_{IN_H} , Input high voltage	$V_{DD} = 3\text{ V}$	$0.7 \times IOV_{DD}$			V
Pin Capacitance				3	pF
POWER REQUIREMENTS					
V_{DD} , IOV_{DD}		2.7		5.5	V
I_{DD} (normal operation)	Excluding load current				
	I_{DD} @ $V_{DD} = +3.6\text{ V to }+5.5\text{ V}$	$V_{IH} = IOV_{DD}$ and $V_{IL} = \text{GND}$	950	1600	μA
	I_{DD} @ $V_{DD} = +2.7\text{ V to }+3.6\text{ V}$	$V_{IH} = IOV_{DD}$ and $V_{IL} = \text{GND}$	900	1500	μA

(1) Linearity tested using a reduced code range of 485 to 64714; output unloaded.

 (2) $V_{REFH} = V_{DD} - 0.1\text{ V}$, $V_{REFL} = \text{GND}$

(3) Specified by design and characterization, not production tested.

ELECTRICAL CHARACTERISTICS (continued)

V_{DD} = 2.7 V to 5.5 V, R_L = 2 kΩ to GND; C_L = 200 pF to GND; all specifications -40°C to +105°C, unless otherwise specified.

PARAMETER	TEST CONDITIONS	MIN	TYP	MAX	UNITS
I _{DD} (all power-down modes)					
I _{DD} @ V _{DD} =+3.6V to +5.5V	V _{IH} = IOV _{DD} and IOV _{IL} =GND		0.2	1	μA
I _{DD} @ V _{DD} =+2.7V to +3.6V	V _{IH} = V _{DD} and V _{IL} =GND		0.05	1	μA
POWER EFFICIENCY					
I _{OUT} /I _{DD}	I _{LOAD} = 2 mA, V _{DD} = +5 V		93%		
TEMPERATURE RANGE					
Specified performance		-40		+105	°C

TIMING CHARACTERISTICS

V_{DD} = 2.7 V to 5.5 V, R_L = 2 kΩ to GND; all specifications -40°C to +105°C, unless otherwise specified.

SYMBOL	PARAMETER	TEST CONDITIONS	MIN	TYP	MAX	UNITS
f _{SCL}	SCL clock frequency	Standard mode			100	kHz
		Fast mode			400	kHz
		High-Speed Mode, C _B = 100 pF max			3.4	MHz
		High-speed mode, C _B = 400 pF max			1.7	MHz
t _{BUF}	Bus free time between a STOP and START condition	Standard mode	4.7			μs
		Fast mode	1.3			μs
t _{HD} ; t _{STA}	Hold time (repeated) START condition	Standard mode	4.0			μs
		Fast mode	600			ns
		High-speed mode	160			ns
t _{LOW}	LOW period of the SCL clock	Standard mode	4.7			μs
		Fast mode	1.3			μs
		High-speed mode, C _B = 100 pF max	160			ns
		High-speed mode, C _B = 400 pF max	320			ns
t _{HIGH}	HIGH period of the SCL clock	Standard mode	4.0			μs
		Fast mode	600			ns
		High-Speed Mode, C _B = 100 pF max	60			ns
		High-speed mode, C _B = 400 pF max	120			ns
t _{SU} ; t _{STA}	Setup time for a repeated START condition	Standard mode	4.7			μs
		Fast mode	600			ns
		High-speed mode	160			ns
t _{SU} ; t _{DAT}	Data setup time	Standard mode	250			ns
		Fast mode	100			ns
		High-speed mode	10			ns
t _{HD} ; t _{DAT}	Data hold time	Standard mode	0		3.45	μs
		Fast mode	0		0.9	μs
		High-speed mode, C _B = 100 pF max	0		70	ns
		High-speed mode, C _B = 400 pF max	0		150	ns
t _{RCL}	Rise time of SCL signal	Standard mode			1000	ns
		Fast mode	20 + 0.1C _B		300	ns
		High-speed mode, C _B = 100 pF max	10		40	ns
		High-speed mode, C _B = 400 pF max	20		80	ns

TIMING CHARACTERISTICS (continued)
 $V_{DD} = 2.7\text{ V to }5.5\text{ V}$, $R_L = 2\text{ k}\Omega$ to GND; all specifications $-40^\circ\text{C to }+105^\circ\text{C}$, unless otherwise specified.

SYMBOL	PARAMETER	TEST CONDITIONS	MIN	TYP	MAX	UNITS
t_{RCL1}	Rise time of SCL signal after a repeated START condition and after an acknowledge BIT	Standard mode			1000	ns
		Fast mode	$20 + 0.1C_B$		300	ns
		High-speed mode, $C_B = 100\text{ pF max}$	10		80	ns
		High-speed mode, $C_B = 400\text{ pF max}$	20		160	ns
t_{FCL}	Fall time of SCL signal	Standard mode			300	ns
		Fast mode	$20 + 0.1C_B$		300	ns
		High-speed mode, $C_B = 100\text{ pF max}$	10		40	ns
		High-speed mode, $C_B = 400\text{ pF max}$	20		80	ns
t_{RDA}	Rise time of SDA signal	Standard mode			1000	ns
		Fast mode	$20 + 0.1C_B$		300	ns
		High-speed mode, $C_B = 100\text{ pF max}$	10		80	ns
		High-speed mode, $C_B = 400\text{ pF max}$	20		160	ns
t_{FDA}	Fall time of SDA signal	Standard mode			300	ns
		Fast mode	$20 + 0.1C_B$		300	ns
		High-speed mode, $C_B = 100\text{ pF max}$	10		80	ns
		High-speed mode, $C_B = 400\text{ pF max}$	20		160	ns
$t_{SU}; t_{STO}$	Setup time for STOP condition	Standard mode	4.0			μs
		Fast mode	600			ns
		High-speed mode	160			ns
C_B	Capacitive load for SDA and SCL				400	pF
t_{SP}	Pulse width of spike suppressed	Fast mode			50	ns
		High-speed mode			10	ns
V_{NH}	Noise margin at the HIGH level for each connected device (including hysteresis)	Standard mode	$0.2 V_{DD}$			V
		Fast mode				
		High-speed mode				
V_{NL}	Noise margin at the LOW level for each connected device (including hysteresis)	Standard mode	$0.1 V_{DD}$			V
		Fast mode				
		High-speed mode				

TYPICAL CHARACTERISTICS

At $T_A = +25^\circ\text{C}$, unless otherwise noted.

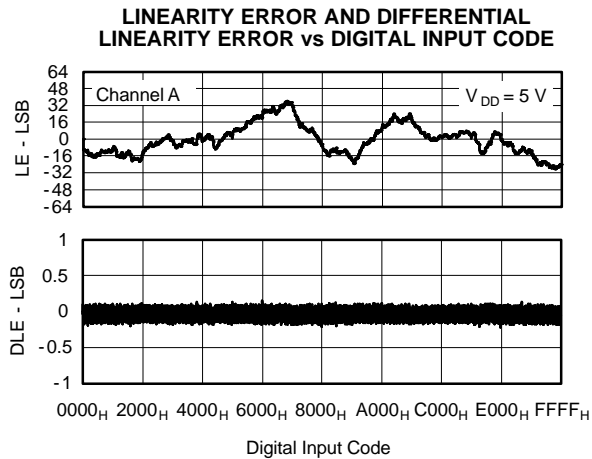

Figure 1.

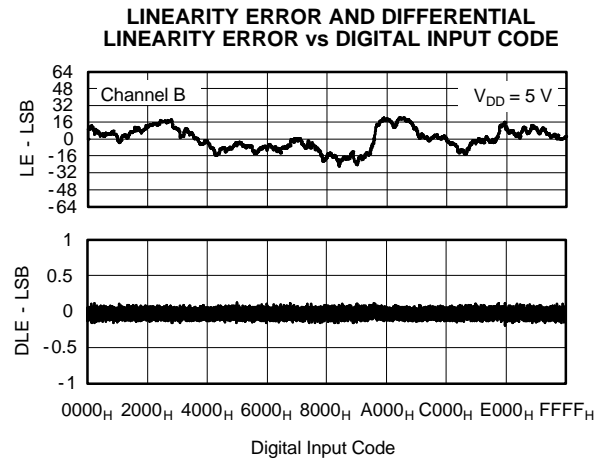

Figure 2.

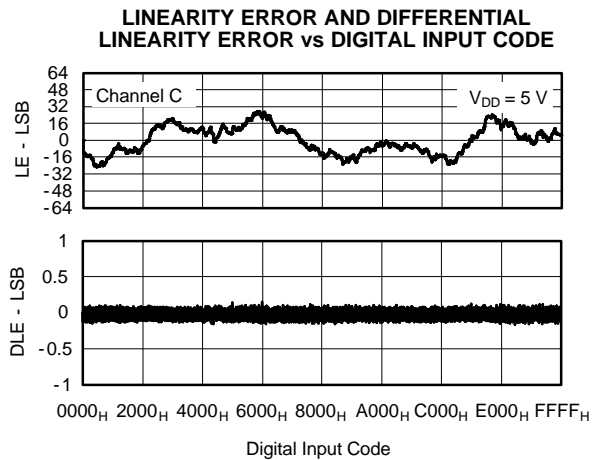

Figure 3.

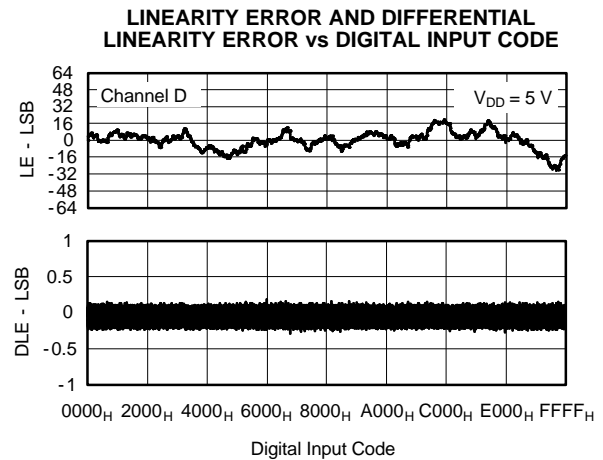

Figure 4.

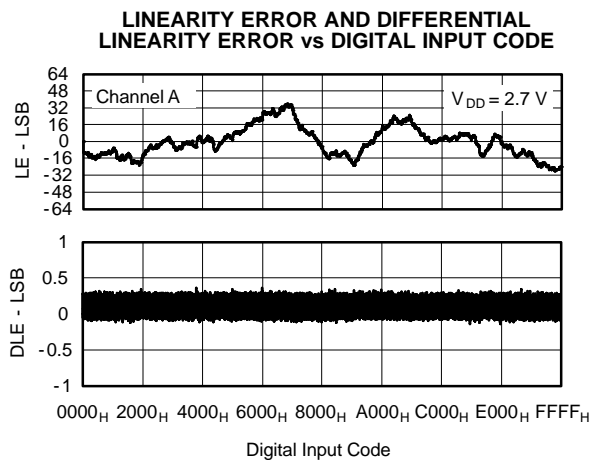

Figure 5.

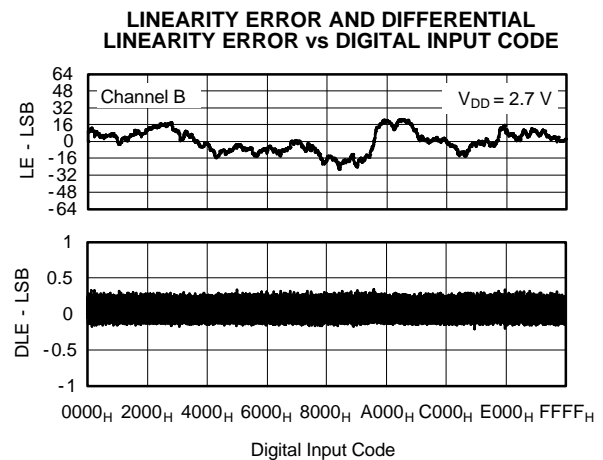

Figure 6.

TYPICAL CHARACTERISTICS (continued)

At $T_A = +25^\circ\text{C}$, unless otherwise noted.

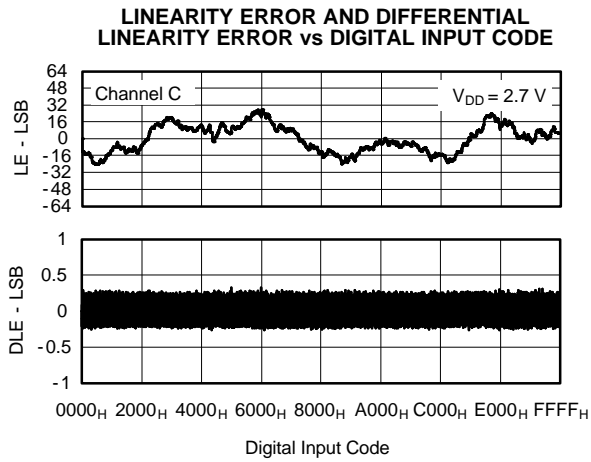

Figure 7.

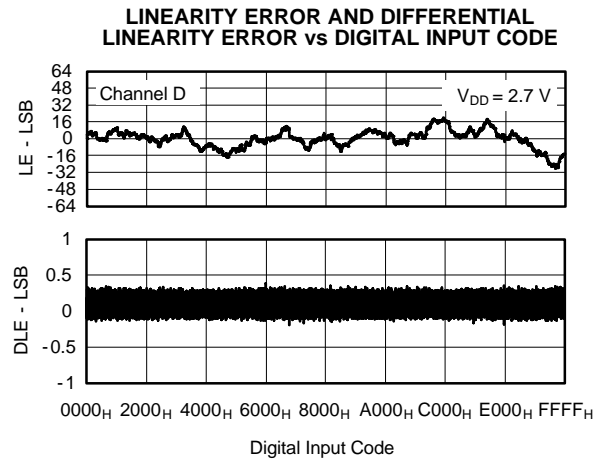

Figure 8.

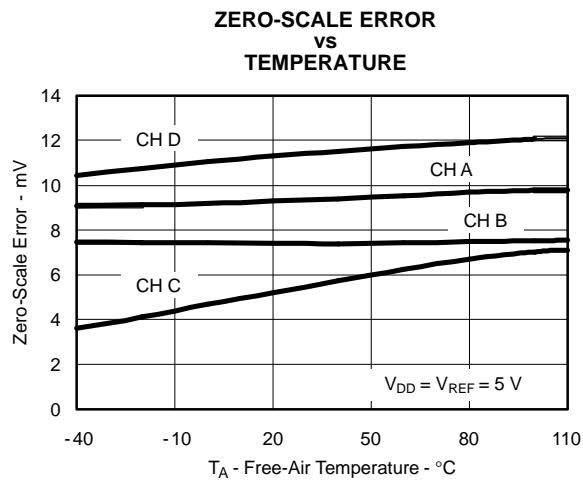

Figure 9.

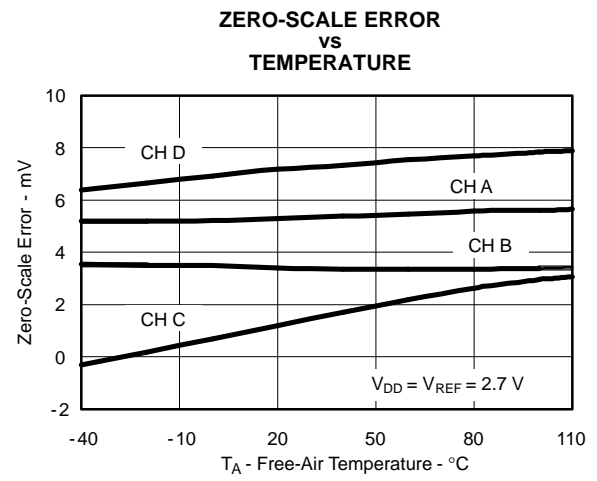

Figure 10.

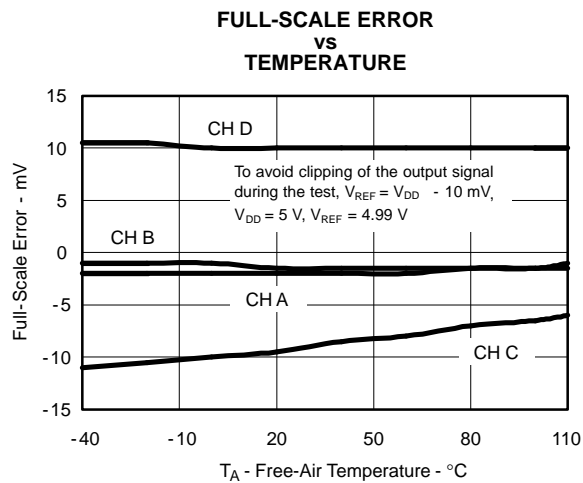

Figure 11.

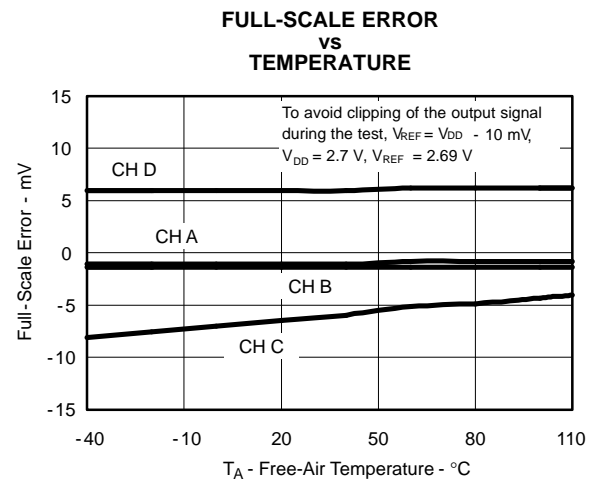

Figure 12.

TYPICAL CHARACTERISTICS (continued)

At $T_A = +25^\circ\text{C}$, unless otherwise noted.

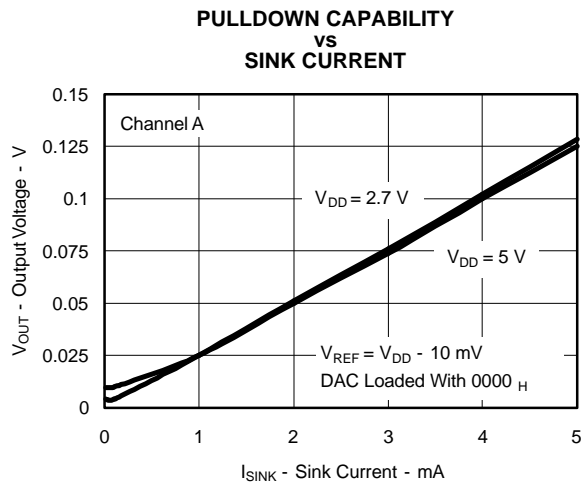

Figure 13.

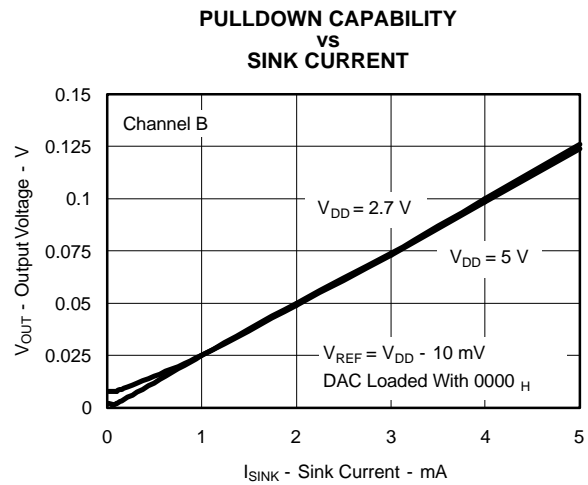

Figure 14.

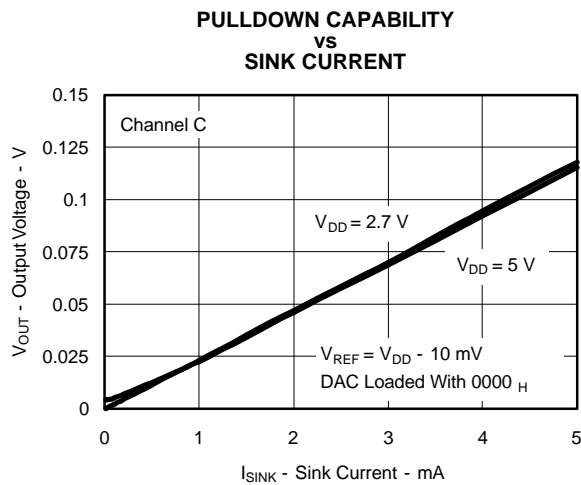

Figure 15.

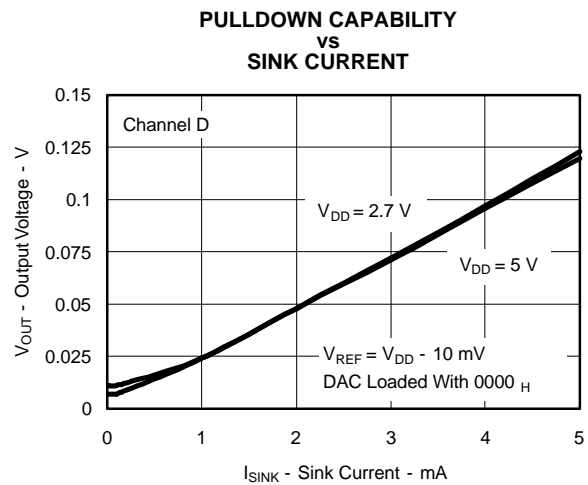

Figure 16.

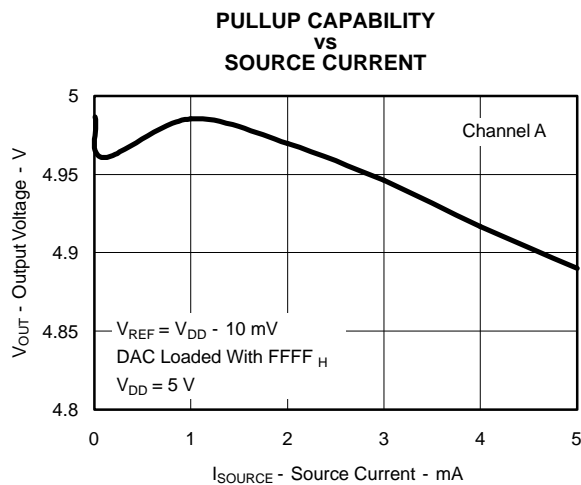

Figure 17.

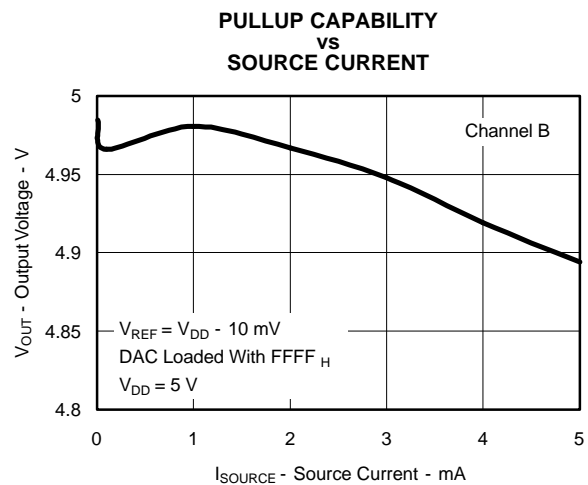
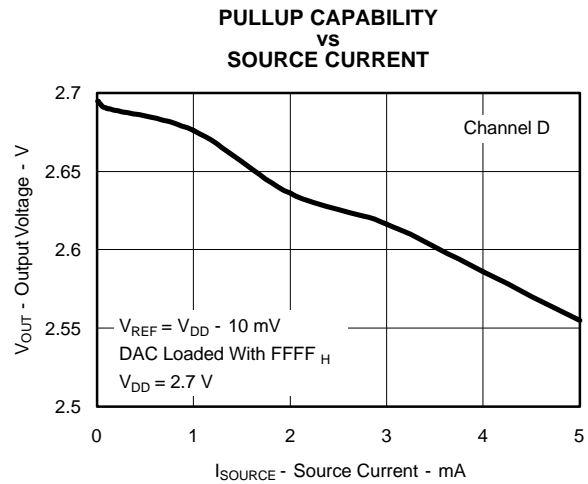
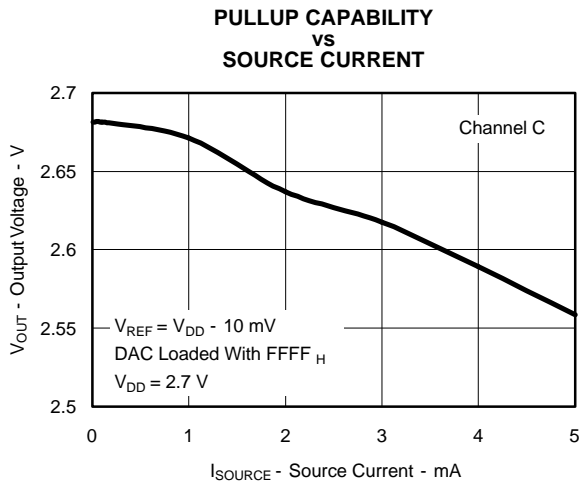
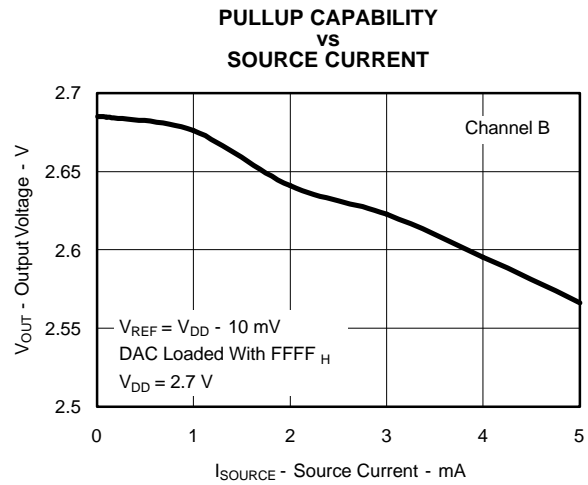
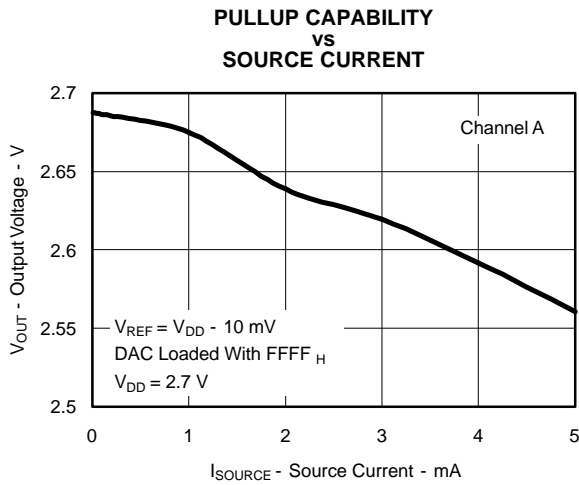
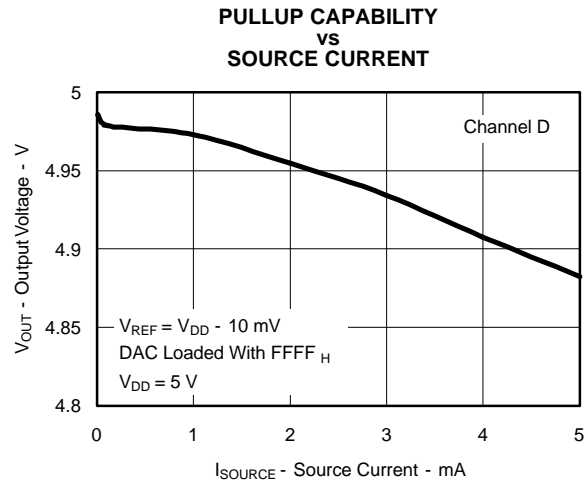
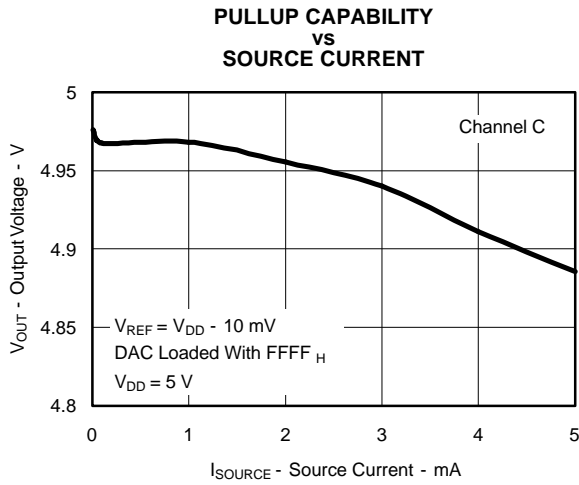

Figure 18.

TYPICAL CHARACTERISTICS (continued)

At $T_A = +25^\circ\text{C}$, unless otherwise noted.



TYPICAL CHARACTERISTICS (continued)

At $T_A = +25^\circ\text{C}$, unless otherwise noted.

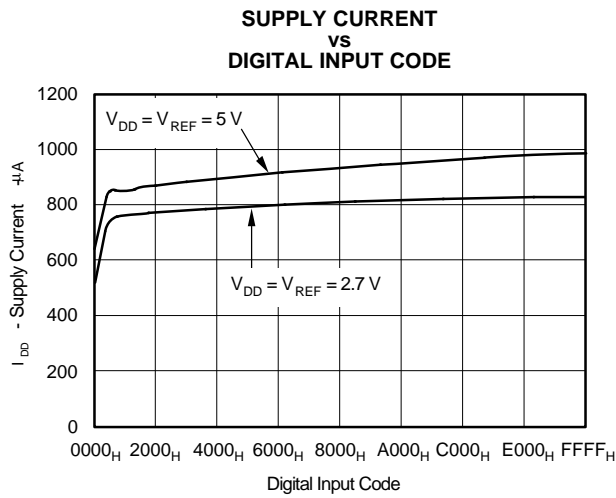

Figure 25.

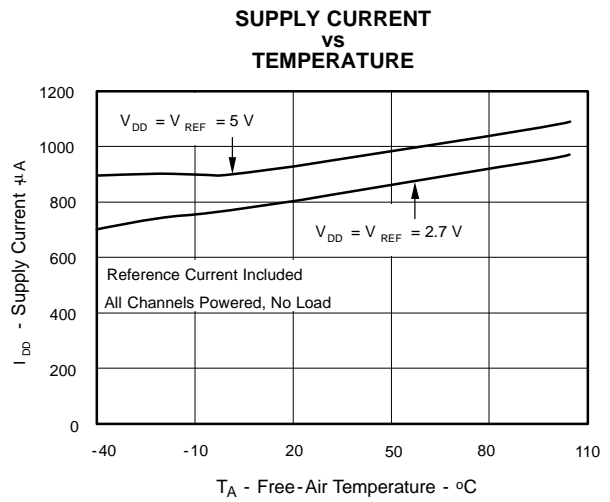

Figure 26.

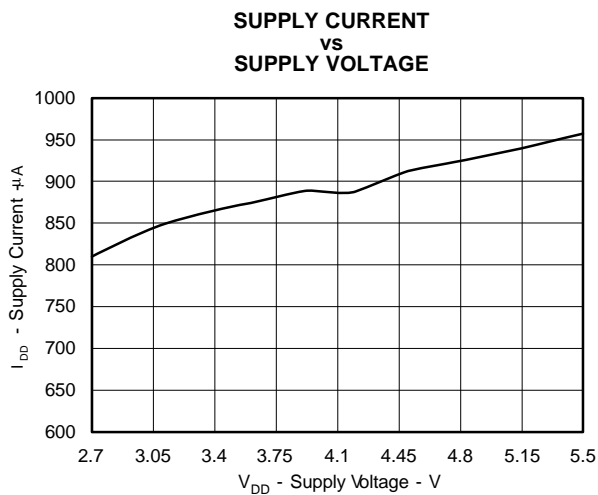

Figure 27.

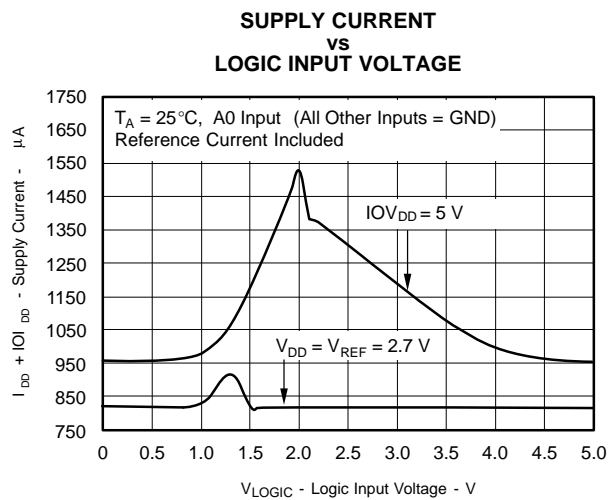

Figure 28.

TYPICAL CHARACTERISTICS (continued)

At $T_A = +25^\circ\text{C}$, unless otherwise noted.

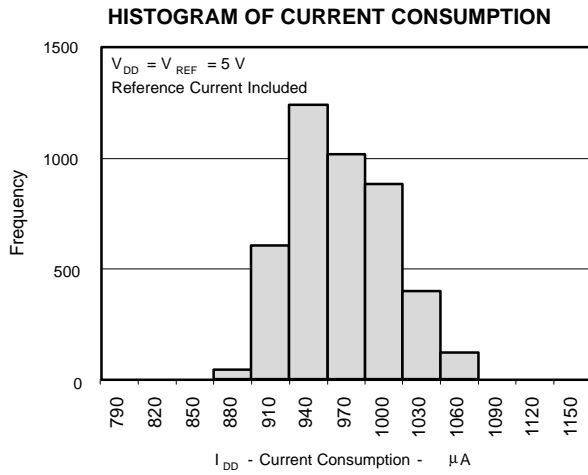

Figure 29.

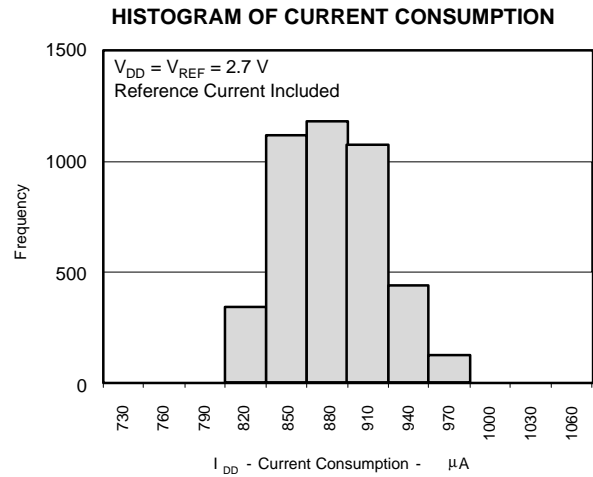

Figure 30.

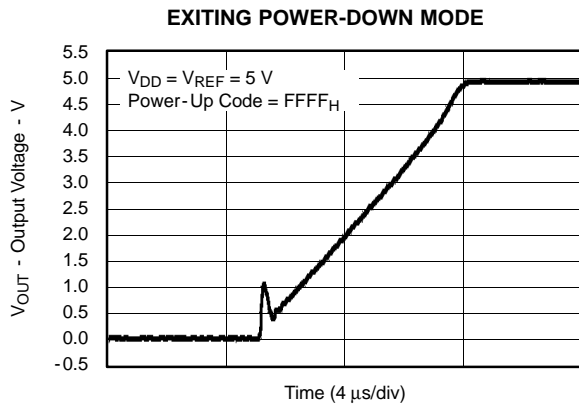

Figure 31.

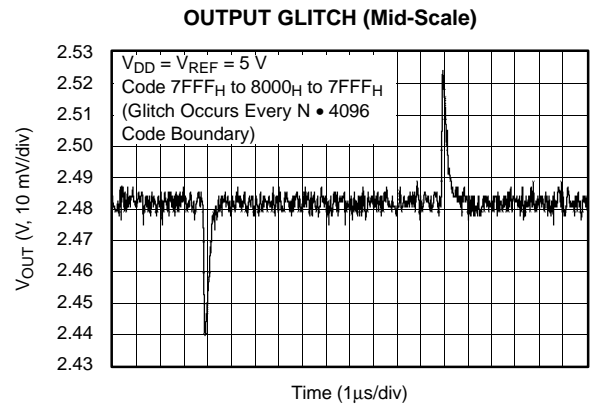

Figure 32.

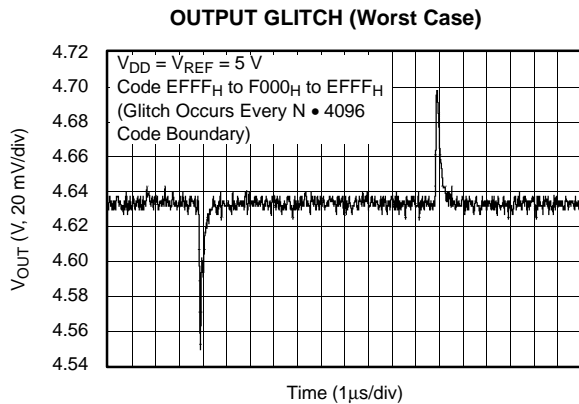

Figure 33.

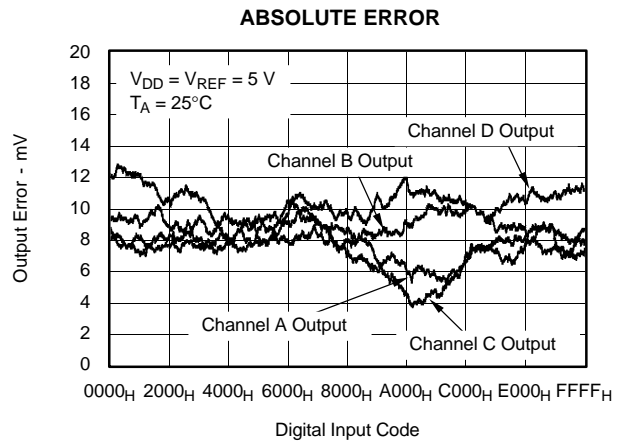

Figure 34.

TYPICAL CHARACTERISTICS (continued)

At $T_A = +25^\circ\text{C}$, unless otherwise noted.

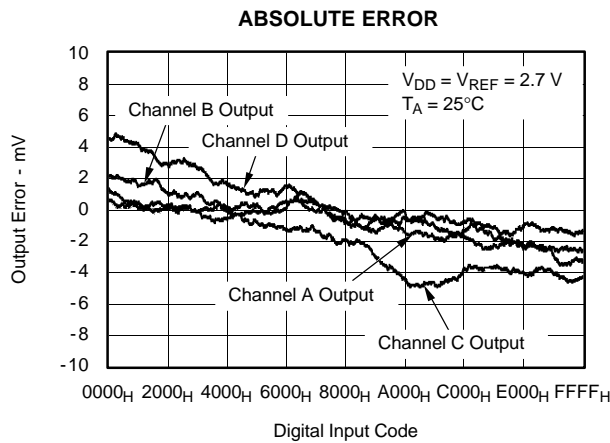

Figure 35.

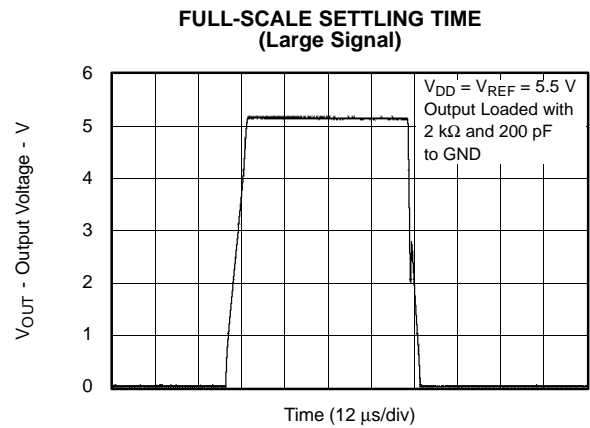

Figure 36.

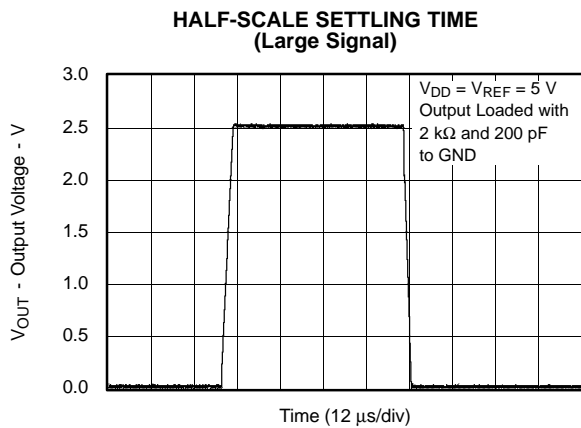

Figure 37.

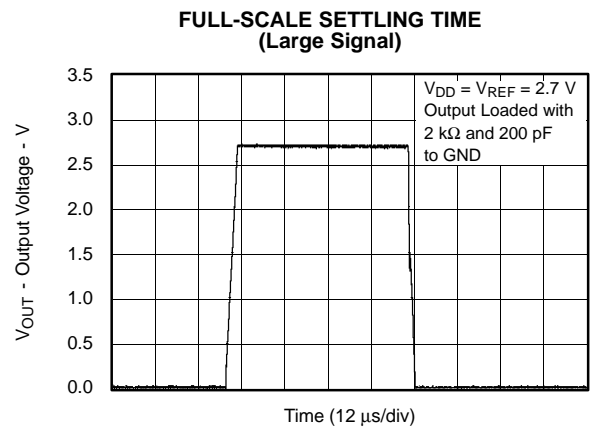

Figure 38.

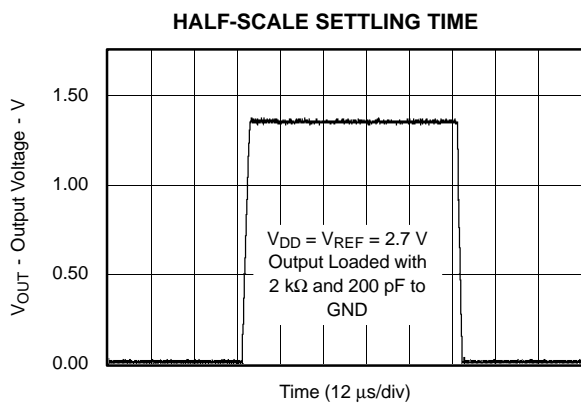

Figure 39.

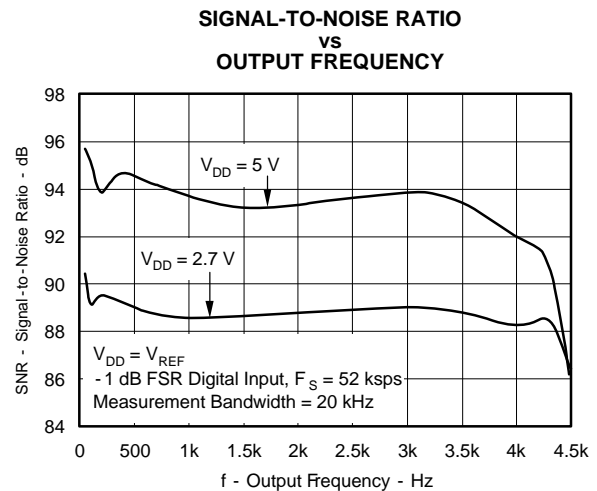

Figure 40.

TYPICAL CHARACTERISTICS (continued)

At $T_A = +25^\circ\text{C}$, unless otherwise noted.

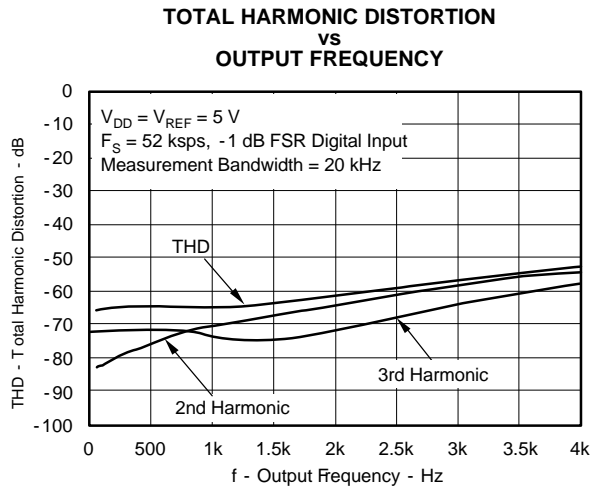

Figure 41.

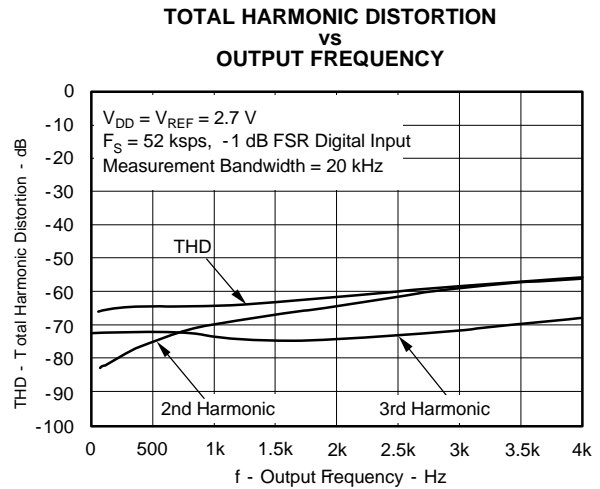

Figure 42.

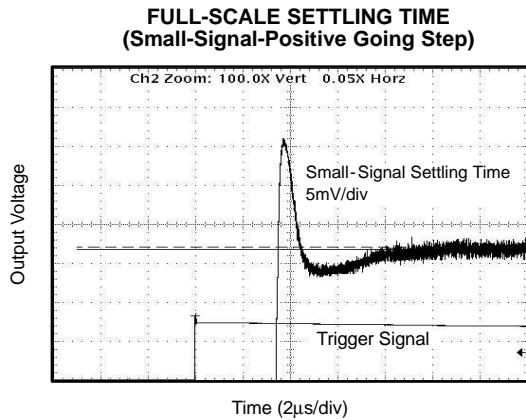

Figure 43.

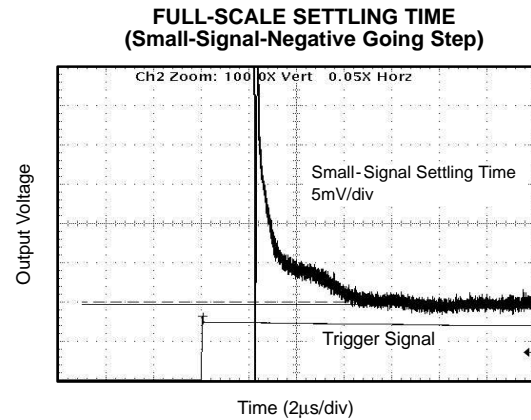

Figure 44.

THEORY OF OPERATION

D/A SECTION

The architecture of the DAC8574 consists of a string DAC followed by an output buffer amplifier. Figure 45 shows a generalized block diagram of the DAC architecture.

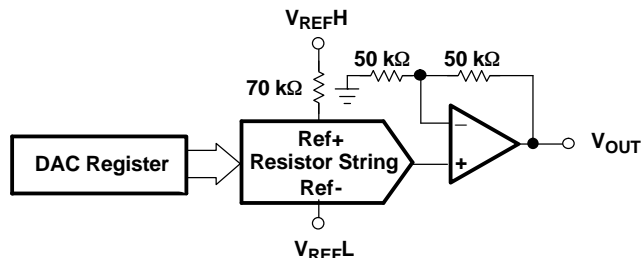

Figure 45. R-String DAC Architecture

The input coding to the DAC8574 is unsigned binary, which gives the ideal output voltage as:

$$V_{OUT} = V_{REFL} + (V_{REFH} - V_{REFL}) \times \frac{D}{65536}$$

Where D = decimal equivalent of the binary code that is loaded to the DAC register; it can range from 0 to 65535.

RESISTOR STRING

The resistor string section is shown in Figure 46. It is basically a divide-by-2 resistor, followed by a string of resistors, each of value R. The code loaded into the DAC register determines at which node on the string the voltage is tapped off to be fed into the output amplifier by closing one of the switches connecting the string to the amplifier. Because the architecture consists of a string of resistors, it is specified monotonic.

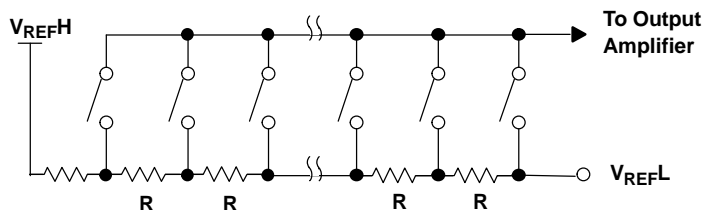

Figure 46. Typical Resistor String

Output Amplifier

The output buffer is a gain-of-2 noninverting amplifiers, capable of generating rail-to-rail voltages on its output, which gives an output range of 0V to V_{DD} . It is capable of driving a load of 2 kΩ in parallel with 1000 pF to GND. The source and sink capabilities of the output amplifier can be seen in the typical curves. The slew rate is 1 V/μs with a half-scale settling time of 8 μs with the output unloaded.

I²C Interface

I²C is a 2-wire serial interface developed by Philips Semiconductor (see I²C-Bus Specification, Version 2.1, January 2000). The bus consists of a data line (SDA) and a clock line (SCL) with pullup structures. When the bus is *idle*, both SDA and SCL lines are pulled high. All the I²C compatible devices connect to the I²C bus through open drain I/O pins, SDA and SCL. A *master* device, usually a microcontroller or a digital signal processor, controls the bus. The master is responsible for generating the SCL signal and device addresses. The master also generates specific conditions that indicate the START and STOP of data transfer. A *slave* device receives and/or transmits data on the bus under control of the master device.

THEORY OF OPERATION (continued)

The DAC8574 works as a slave and supports the following data transfer *modes*, as defined in the I²C-Bus Specification: standard mode (100 kbps), fast mode (400 kbps), and high-speed mode (3.4 Mbps). The data transfer protocol for standard and fast modes is exactly the same, therefore they are referred to as F/S-mode in this document. The protocol for high-speed mode is different from the F/S-mode, and it is referred to as HS-mode. The DAC8574 supports 7-bit addressing; 10-bit addressing, and general call address are *not* supported.

F/S-Mode Protocol

- The *master* initiates data transfer by generating a *start condition*. The *start condition* is when a high-to-low transition occurs on the SDA line while SCL is high, as shown in Figure 47. All I²C-compatible devices should recognize a *start condition*.
- The master then generates the SCL pulses, and transmits the 7-bit address and the *read/write direction bit* R/\overline{W} on the SDA line. During all transmissions, the master ensures that data is *valid*. A *valid data condition* requires the SDA line to be stable during the entire high period of the clock pulse (see Figure 48). All devices recognize the address sent by the master and compare it to their internal fixed addresses. Only the slave device with a matching address generates an *acknowledge* (see Figure 49) by pulling the SDA line low during the entire high period of the 9th SCL cycle. Upon detecting this acknowledge, the master knows that communication link with a slave has been established.
- The master generates further SCL cycles to either *transmit* data to the slave (R/\overline{W} bit 1) or *receive* data from the slave (R/\overline{W} bit 0). In either case, the *receiver* needs to acknowledge the data sent by the *transmitter*. So acknowledge signal can either be generated by the master or by the slave, depending on which one is the receiver. 9-bit valid data sequences consisting of 8-bit data and 1-bit acknowledge can continue as long as necessary.
- To signal the end of the data transfer, the master generates a *stop condition* by pulling the SDA line from low to high while the SCL line is high (see Figure 47). This releases the bus and stops the communication link with the addressed slave. All I²C compatible devices must recognize the stop condition. Upon the receipt of a *stop condition*, all devices know that the bus is released, and they wait for a *start condition* followed by a matching address.

H/S-Mode Protocol

- When the bus is idle, both SDA and SCL lines are pulled high by the pullup devices.
- The master generates a start condition followed by a valid serial byte containing H/S master code 00001XXX. This transmission is made in F/S-mode at no more than 400 Kbps. No device is allowed to acknowledge the H/S master code, but all devices must recognize it and switch their internal setting to support 3.4 Mbps operation.
- The master then generates a *repeated start condition* (a repeated start condition has the same timing as the start condition). After this repeated start condition, the protocol is the same as F/S-mode, except that transmission speeds up to 3.4 Mbps are allowed. A stop condition ends the H/S-mode and switches all the internal settings of the slave devices to support the F/S-mode. Instead of using a stop condition, repeated start conditions should be used to secure the bus in H/S-mode.

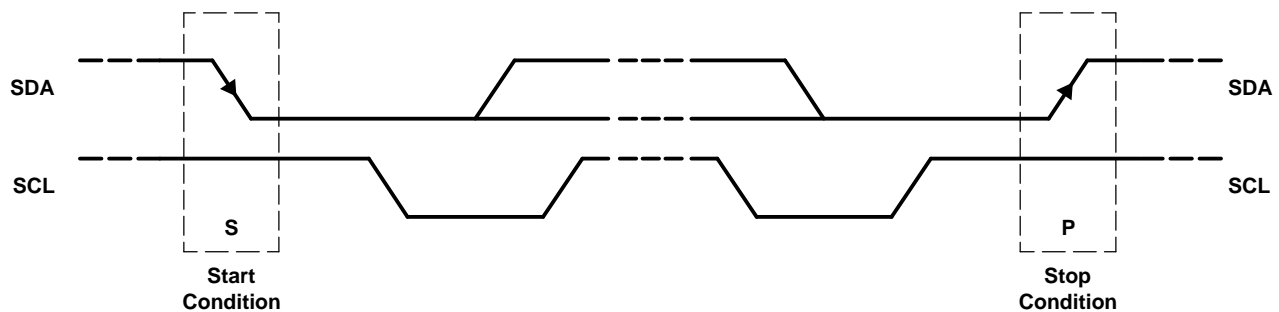

Figure 47. START and STOP Conditions

THEORY OF OPERATION (continued)

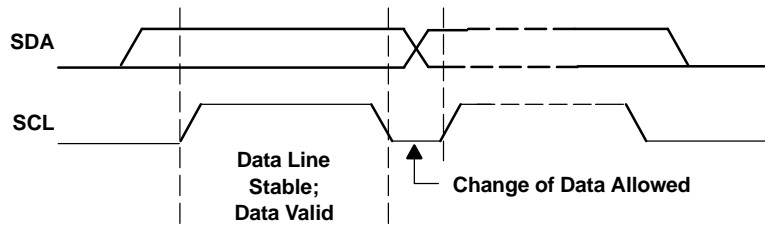

Figure 48. Bit Transfer on the I²C Bus

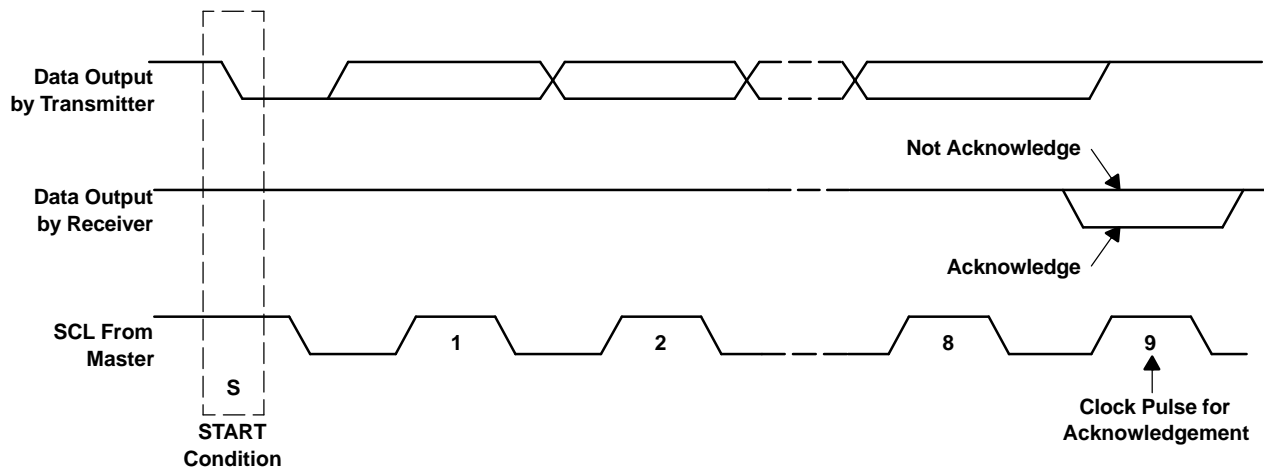

Figure 49. Acknowledge on the I²C Bus

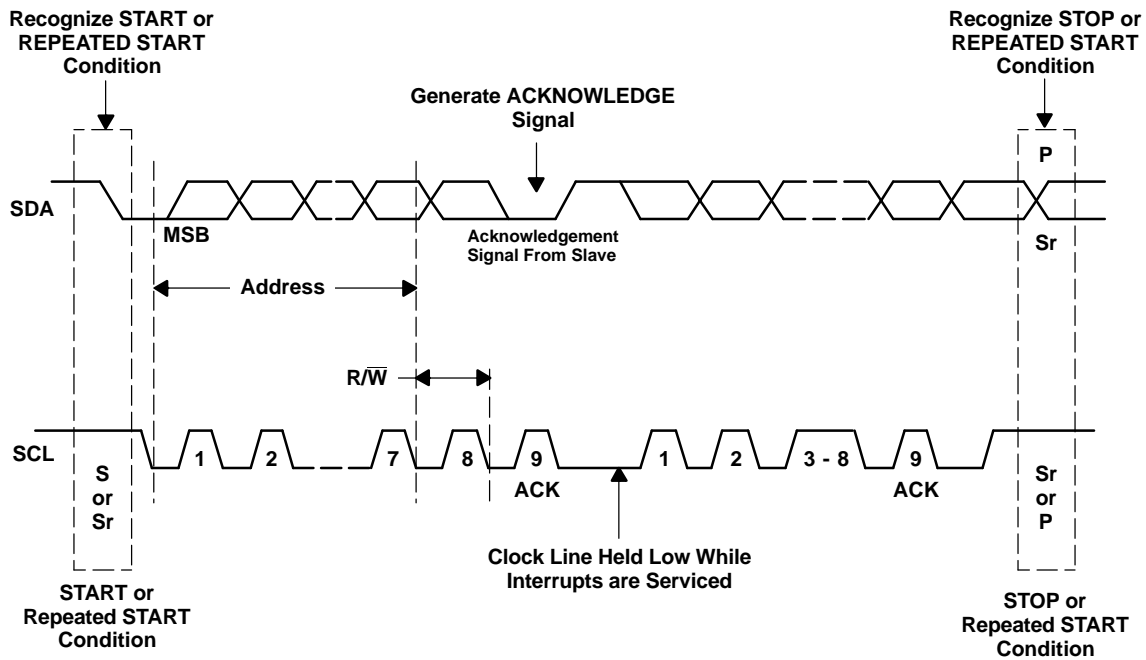

Figure 50. Bus Protocol

DAC8574 I²C Update Sequence

The DAC8574 requires a start condition, a valid I²C address, a control byte, an MSB byte, and an LSB byte for a single update. After the receipt of each byte, DAC8574 acknowledges by pulling the SDA line low during the high period of a single clock pulse. A valid I²C address selects the DAC8574. The control byte sets the operational mode of the selected DAC8574. Once the operational mode is selected by the control byte, DAC8574 expects an MSB byte followed by an LSB byte for data update to occur. DAC8574 performs an update on the falling edge of the acknowledge signal that follows the LSB byte.

Control byte needs not to be resent until a change in operational mode is required. The bits of the control byte continuously determine the type of update performed. Thus, for the first update, DAC8574 requires a start condition, a valid I²C address, a control byte, an MSB byte and an LSB byte. For all consecutive updates, DAC8574 needs an MSB byte and an LSB byte as long as the control command remains the same.

Using the I²C high-speed mode ($f_{scI} = 3.4$ MHz), the clock running at 3.4 MHz, each 16-bit DAC update other than the first update can be done within 18 clock cycles (MSB byte, acknowledge signal, LSB byte, acknowledge signal), at 188.88 KSPS. Using the fast mode ($f_{scI} = 400$ kHz), clock running at 400 kHz, maximum DAC update rate is limited to 22.22 KSPS. Once a stop condition is received DAC8574 releases the I²C bus and awaits a new start condition.

Address Byte

MSB					LSB		
1	0	0	1	1	A1	A0	R/W

The address byte is the first byte received following the START condition from the master device. The first five bits (MSBs) of the address are factory preset to 10011. The next two bits of the address are the device select bits A1 and A0. The A1, A0 address inputs can be connected to V_{DD} or digital GND, or can be actively driven by TTL/CMOS logic levels. The device address is set by the state of these pins during the power-up sequence of the DAC8574. Up to 16 devices (DAC8574) can still be connected to the same I²C-Bus.

Broadcast Address Byte

MSB							LSB
1	0	0	1	0	0	0	0

Broadcast addressing is also supported by DAC8574. Broadcast addressing can be used for synchronously updating or powering down multiple DAC8574 devices. DAC8574 is designed to work with other members of the DAC857x and DAC757x families to support multichannel synchronous update. Using the broadcast address, DAC8574 responds regardless of the states of the address pins. Broadcast is supported only in write mode (Master writes to DAC8574).

Control Byte

MSB							LSB
A3	A2	L1	L0	X	Sel1	Sel0	PD0

Table 1. Control Register Bit Descriptions

Bit Name	Bit Number/Description	
A3	Extended Address Bit	
A2	Extended Address Bit	
L1	Load1 (Mode Select) Bit	
L2	Load0 (Mode Select) Bit	
	00	Store I ² C data. The contents of MS-BYTE and LS-BYTE (or power down information) are stored in the temporary register of a selected channel. This mode does not change the DAC output of the selected channel.
	01	Update selected DAC with I ² C data. Most commonly utilized mode. The contents of MS-BYTE and LS-BYTE (or power down information) are stored in the temporary register and in the DAC register of the selected channel. This mode changes the DAC output of the selected channel with the new data.
	10	4-Channel synchronous update. The contents of MS-BYTE and LS-BYTE (or power down information) are stored in the temporary register and in the DAC register of the selected channel. Simultaneously, the other three channels get updated with previously stored data from the temporary register. This mode updates all four channels together.
	11	Broadcast update mode. This mode has two functions. In broadcast mode, DAC8574 responds regardless of local address matching, and channel selection becomes irrelevant as all channels update. This mode is intended to enable up to 64 channels simultaneous update, if used with the I ² C broadcast address (1001 0000).
		If Sel1=0
		All four channels are updated with the contents of their temporary register data.
		If Sel1=1
		All four channels are updated with the MS-BYTE and LS-BYTE data or powerdown.
Sel1	Buff Sel1 Bit	
Sel0	Buff Sel0 Bit	
	Channel Select Bits	
	00	Channel A
	01	Channel B
	10	Channel C
	11	Channel D
PD0	Power Down Flag	
	0	Normal operation
	1	Power-down flag (MSB7 and MSB6 indicate a power-down operation, as shown in Table 2).

Table 2. Control Byte

C7	C6	C5	C4	C3	C2	C1	C0	MSB7	MSB6	MSB5...	DESCRIPTION
A3	A2	Load1	Load0	Don't Care	Ch Sel 1	Ch Sel 0	PD0	MSB (PD1)	MSB-1 (PD2)	MSB-2 ...LSB	
(Address Select)											
(A3 and A2 should correspond to the package address set via pins A3 and A2.)		0	0	X	0	0	0	Data			Write to temporary register A (TRA) with data
		0	0	X	0	1	0	Data			Write to temporary register B (TRB) with data
		0	0	X	1	0	0	Data			Write to temporary register C (TRC) with data
		0	0	X	1	1	0	Data			Write to temporary register D (TRD) with data
		0	0	X	(00, 01, 10, or 11)		1	see Table 8	0	Write to TRx (selected by C2 & C1 w/Powerdown Command)	
		0	1	X	(00, 01, 10, or 11)		0	Data			Write to TRx (selected by C2 & C1 and load DACx w/data)
		0	1	X	(00, 01, 10, or 11)		1	see Table 8	0	Power-down DACx (selected by C2 and C1)	
		1	0	X	(00, 01, 10, or 11)		0	Data			Write to TRx (selected by C2 & C1 w/ data and load all DACs)
		1	0	X	(00, 01, 10, or 11)		1	see Table 8	0	Power-down DACx (selected by C2 and C1) & load all DACs	
Broadcast Modes (controls up to 4 devices on a single serial bus)											
X	X	1	1	X	0	X	X	X			Update all DACs, all devices with previously stored TRx data
X	X	1	1	X	1	X	0	Data			Update all DACs, all devices with MSB[7:0] and LSB[7:0] data
X	X	1	1	X	1	X	1	see Table 8	0	Power-down all DACs, all devices	

Most Significant Byte

Most Significant Byte MSB[7:0] consists of eight most significant bits of 16-bit unsigned binary D/A conversion data. C0=1, MSB[7], MSB[6] indicate a powerdown operation as shown in Table 8.

Least Significant Byte

Least Significant Byte LSB[7:0] consists of the 8 least significant bits of the 16bit unsigned binary D/A conversion data. DAC8574 updates at the falling edge of the acknowledge signal that follows the LSB[0] bit.

Default Readback Condition

If the user initiates a readback of a specified channel without first writing data to that specified channel, the default readback is all zeros, since the readback register is initialized to 0 during the power on reset phase.

LDAC Functionality

Depending on the control byte, DACs are synchronously updated on the falling edge of the acknowledge signal that follows LS byte. The LDAC pin is required only when an external timing signal is used to update all the channels of the DAC asynchronously. LDAC is a positive edge triggered asynchronous input that allows four DAC output voltages to be updated simultaneously with temporary register data. The LDAC trigger should only be used after the buffers temporary registers are properly updated through software.

DAC8574 Registers

Table 3. DAC8574 Architecture Register Descriptions

Register	Description
CTRL[7:0]	Stores 8-bit wide control byte sent by the master
MSB[7:0]	Stores the 8 most significant bits of unsigned binary data sent by the master. Can also store 2-bit power-down data.
LSB[7:0]	Stores the 8 least significant bits of unsigned binary data sent by the master.
TRA[17:0], TRB[17:0], TRC[17:0], TRD[17:0]	18-bit temporary storage registers assigned to each channel. Two MSBs store power-down information, 16 LSBs store data.
DRA[17:0], DRB[17:0], DRC[17:0], DRD[17:0]	18-bit DAC registers for each channel. Two MSBs store power-down information, 16 LSBs store DAC data. An update of this register means a DAC update with data or power-down.

DAC8574 as a Slave Receiver - Standard and Fast Mode

Figure 51 shows the standard and fast mode master transmitter addressing a DAC8574 *Slave Receiver* with a 7-bit address.

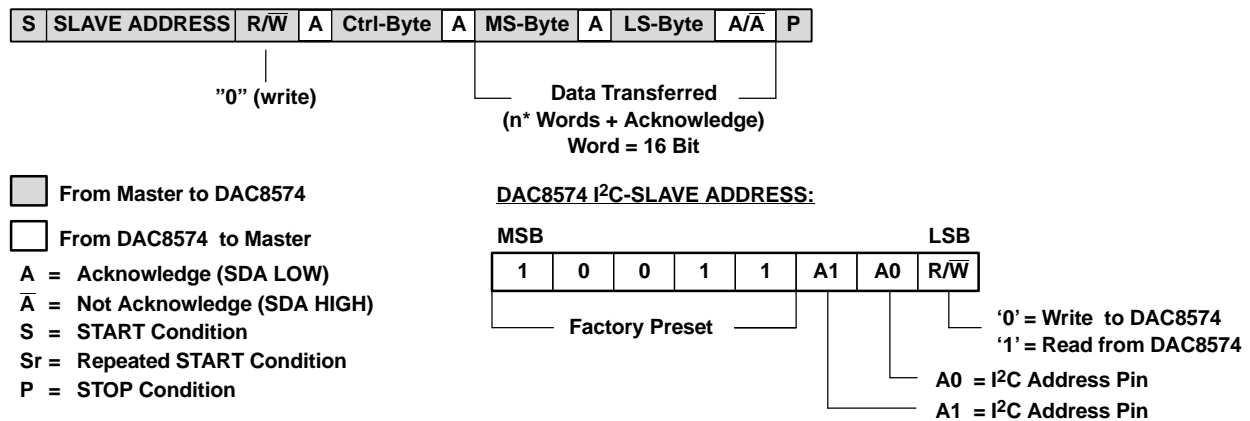

Figure 51. Standard and Fast Mode: Slave Receiver

DAC8574 as a Slave Receiver - High-Speed Mode

Figure 52 shows the high-speed mode master transmitter addressing a DAC8574 *Slave Receiver* with a 7-bit address.

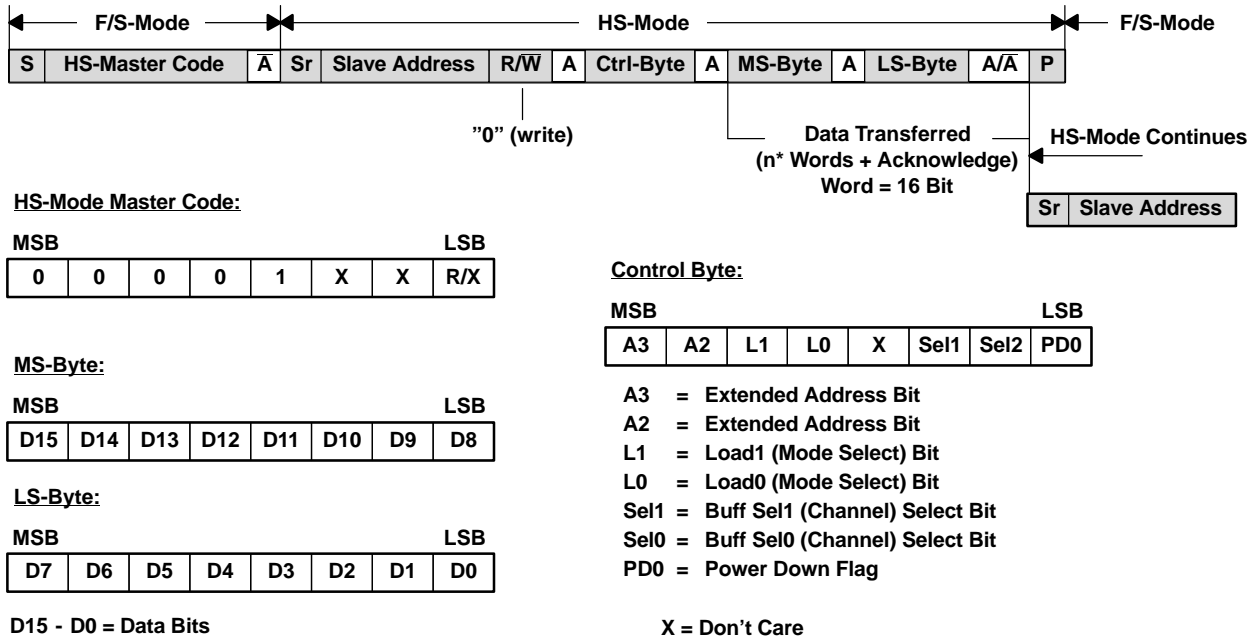

Figure 52. High-Speed Mode: Slave Receiver

Master Transmitter Writing to a Slave Receiver (DAC8574) in Standard/Fast Modes

All write access sequences begin with the device address (with $R/\overline{W} = 0$) followed by the control byte. This control byte specifies the operation mode of DAC8574 and determines which channel of DAC8574 is being accessed in the subsequent read/write operation. The LSB of the control byte (PD0-Bit) determines if the following data is power-down data or regular data.

With (PD0-Bit = 0) the DAC8574 expects to receive data in the following sequence *HIGH-BYTE –LOW-BYTE – HIGH-BYTE – LOW-BYTE...*, until a STOP Condition or REPEATED START Condition on the I²C-Bus is recognized (refer to the DATA INPUT MODE section of Table 4).

With (PD0-Bit = 1) the DAC8574 expects to receive 2 Bytes of power-down data (refer to the POWER DOWN MODE section of Table 4).

Table 4. Write Sequence in F/S Mode

DATA INPUT MODE									
Transmitter	MSB	6	5	4	3	2	1	LSB	Comment
Master	Start								Begin sequence
Master	1	0	0	1	1	A1	A0	R/ \overline{W}	Write addressing (R/ \overline{W} =0)
DAC8574	DAC8574 Acknowledges								
Master	A3	A2	Load 1	Load 0	x	Buff Sel 1	Buff Sel 0	PD0	Control byte (PD0=0)
DAC8574	DAC8574 Acknowledges								
Master	D15	D14	D13	D12	D11	D10	D9	D8	Writing data word, high byte
DAC8574	DAC8574 Acknowledges								
Master	D7	D6	D5	D4	D3	D2	D1	D0	Writing data word, low byte
DAC8574	DAC8574 Acknowledges								
Master	Data or Stop or Repeated Start ⁽¹⁾								Data or done ⁽²⁾
POWER DOWN MODE									
Transmitter	MSB	6	5	4	3	2	1	LSB	Comment
Master	Start								Begin sequence
Master	1	0	0	1	1	A1	A0	R/ \overline{W}	Write addressing (R/ \overline{W} =0)
DAC8574	DAC8574 Acknowledges								
Master	A3	A2	Load 1	Load 0	x	Buff Sel 1	Buff Sel 0	PD0	Control byte (PD0 = 1)
DAC8574	DAC8574 Acknowledges								
Master	PD1	PD2	0	0	0	0	0	0	Writing data word, high byte
DAC8574	DAC8574 Acknowledges								
Master	0	0	0	0	0	0	0	0	Writing data word, low byte
DAC8574	DAC8574 Acknowledges								
Master	Stop or Repeated Start ⁽¹⁾								Done

- (1) Use repeated START to secure bus operation and loop back to the stage of write addressing for next Write.
- (2) Once DAC8574 is properly addressed and control byte is sent, HIGH–BYTE–LOW–BYTE sequences can repeat until a STOP condition or repeated START condition is received.

Master Transmitter Writing to a Slave Receiver (DAC8574) in HS Mode

When writing data to the DAC8574 in HS-mode, the master begins to transmit what is called the *HS-Master Code* (0000 1XXX) in F/S-mode. No device is allowed to acknowledge the *HS-Master Code*, so the *HS-Master Code* is followed by a NOT acknowledge.

The master then *switches* to HS-mode and issues a *repeated start* condition, followed by the address byte (with R/W = 0) after which the DAC8574 acknowledges by pulling SDA low. This address byte is usually followed by the control byte, which is also acknowledged by the DAC8574. The LSB of the control byte (PD0-Bit) determines if the following data is *power-down data* or regular data.

With (PD0-Bit = 0) the DAC8574 expects to receive data in the following sequence HIGH-BYTE – LOW-BYTE – HIGH-BYTE – LOW-BYTE..., until a STOP condition or *repeated start* condition on the I²C-Bus is recognized (refer to Table 5 HS-MODE WRITE SEQUENCE - DATA).

With (PD0-Bit = 1) the DAC8574 expects to receive 2 bytes of power-down data (refer to Table 5 HS-MODE WRITE SEQUENCE - POWER DOWN).

Table 5. Master Transmitter Writes to Slave Receiver (DAC8574) in HS-Mode

HS MODE WRITE SEQUENCE - DATA									
Transmitter	MSB	6	5	4	3	2	1	LSB	Comment
Master	Start								Begin sequence
Master	0	0	0	0	1	X	X	X	HS Mode Master Code
NONE	Not Acknowledge								No device may acknowledge HS master code
Master	Repeated Start								
Master	1	0	0	1	1	A1	A0	R/W	Write addressing (R/W=0)
DAC8574	DAC8574 Acknowledges								
Master	0	0	Load 1	Load 0	0	Buff Sel 1	Buff Sel 0	PD0	Control byte (PD0=0)
DAC8574	DAC8574 Acknowledges								
Master	D15	D14	D13	D12	D11	D10	D9	D8	Writing data word, MSB
DAC8574	DAC8574 Acknowledges								
Master	D7	D6	D5	D4	D3	D2	D1	D0	Writing data word, LSB
DAC8574	DAC8574 Acknowledges								
Master	Data or Stop or Repeated Start ⁽¹⁾								Data or done ⁽²⁾
HS MODE WRITE SEQUENCE - POWER DOWN									
Transmitter	MSB	6	5	4	3	2	1	LSB	Comment
Master	Start								Begin sequence
Master	0	0	0	0	1	X	X	X	HS Mode Master Code
NONE	Not Acknowledge								No device may acknowledge HS master code
Master	Repeated Start								
Master	1	0	0	1	1	A1	A0	R/W	Write addressing (R/W = 0)
DAC8574	DAC8574 Acknowledges								
Master	0	0	Load 1	Load 2	0	Buff Sel 1	Buff Sel 0	PD0	Control Byte (PD0=1)
DAC8574	DAC8574 Acknowledges								
Master	PD1	PD2	0	0	0	0	0	0	Writing data word, high byte
DAC8574	DAC8574 Acknowledges								
Master	0	0	0	0	0	0	0	0	Writing data word, low byte
DAC8574	DAC8574 Acknowledges								
Master	Stop or repeated start ⁽¹⁾								Done

(1) Use repeated start to secure bus operation and loop back to the stage of write addressing for next Write.

(2) Once DAC8574 is properly addressed and control byte is sent, high-byte-low-byte sequences can repeat until a stop or repeated start condition is received.

DAC8574 as a Slave Transmitter - Standard and Fast Mode

Figure 53 shows the standard and fast mode master transmitter addressing a DAC8574 *Slave Transmitter* with a 7-bit address.

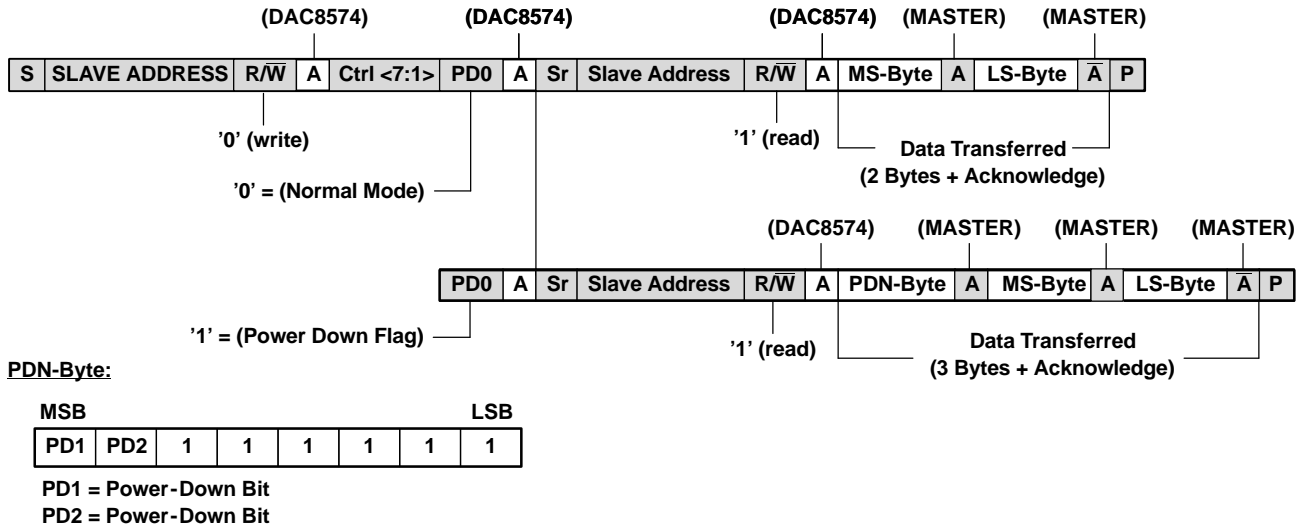

Figure 53. Standard and Fast Mode: Slave Transmitter

DAC8574 as a Slave Transmitter - High-Speed Mode

Figure 54 shows an I^2C -Master addressing DAC8574 in high-speed mode (with a 7-bit address), as a *Slave Transmitter*.

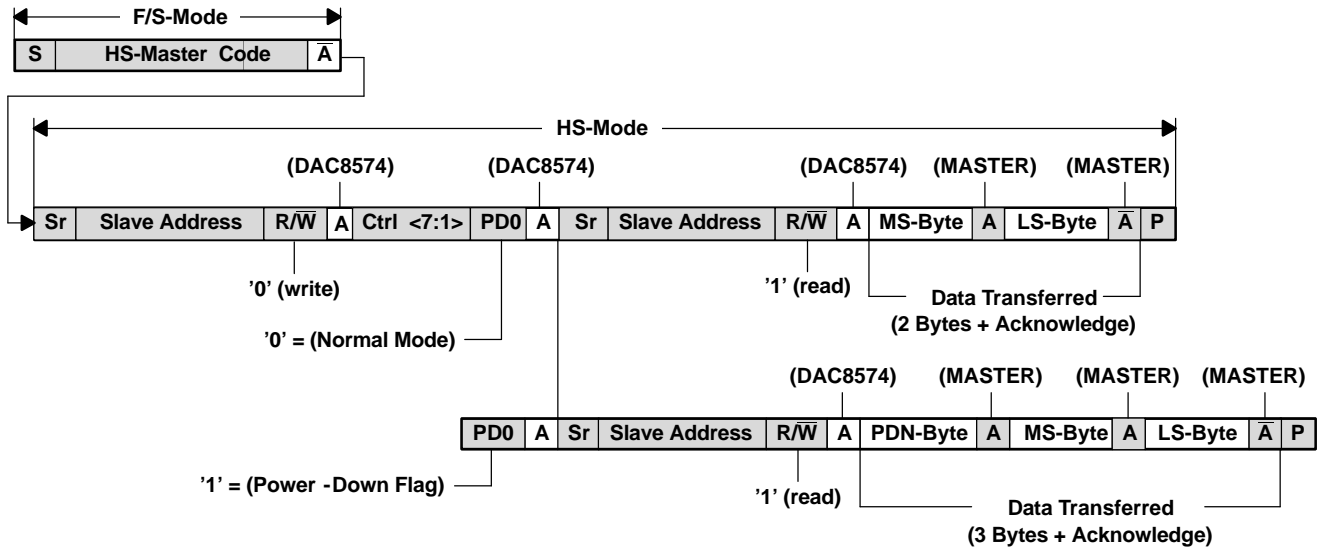

Figure 54. High-Speed Mode: Slave Transmitter

Master Receiver Reading From a Slave Transmitter (DAC8574) in Standard/Fast Modes

When reading data back from the DAC8574, the user begins with an address byte (with $R/\bar{W} = 0$) after which the DAC8574 will acknowledge by pulling SDA low. This address byte is usually followed by the Control Byte, which is also acknowledged by the DAC8574. Following this there is a REPEATED START condition by the Master and the address is resent with ($R/\bar{W} = 1$). This is acknowledged by the DAC8574, indicating that it is prepared to transmit data. Two or three bytes of data are then read back from the DAC8574, depending on the (PD0-Bit). The value of *Buff-Sel1* and *Buff-Sel0* determines, which channel data is read back. A STOP Condition follows.

With the (PD0-Bit = 0) the DAC8574 transmits 2 bytes of data, *HIGH-BYTE* followed by the *LOW-BYTE* (refer to Table 2. Data Readback Mode - 2 bytes).

With the (PD0-Bit = 1) the DAC8574 transmits 3 bytes of data, *POWER-DOWN-BYTE* followed by the *HIGH-BYTE* followed by the *LOW-BYTE* (refer to Table 2. Data Readback Mode - 3 bytes).

Table 6. Read Sequence in F/S Mode

DATA READBACK MODE - 2 BYTES									
Transmitter	MSB	6	5	4	3	2	1	LSB	Comment
Master	Start								Begin sequence
Master	1	0	0	1	1	A1	A0	R/ \bar{W}	Write addressing (R/ \bar{W} =0)
DAC8574	DAC8574 Acknowledges								
Master	A3	A2	Load 1	Load 0	x	Buff Sel 1	Buff Sel 0	PD0	Control byte (PD0=0)
DAC8574	DAC8574 Acknowledges								
Master	Repeated Start								
Master	1	0	0	1	1	A1	A0	R/ \bar{W}	Read addressing (R/ \bar{W} = 1)
DAC8574	DAC8574 Acknowledges								
DAC8574	D15	D14	D13	D12	D11	D10	D9	D8	Reading data word, high byte
Master	Master Acknowledges								
DAC8574	D7	D6	D5	D4	D3	D2	D1	D0	Reading data word, low byte
Master	Master Not Acknowledges								Master signal end of read
Master	Stop or Repeated Start ⁽¹⁾								Done
DATA READBACK MODE - 3 BYTES									
Transmitter	MSB	6	5	4	3	2	1	LSB	Comment
Master	Start								Begin sequence
Master	1	0	0	1	1	A1	A0	R/ \bar{W}	Write addressing (R/ \bar{W} =0)
DAC8574	DAC8574 Acknowledges								
Master	A3	A2	Load 1	Load 0	x	Buff Sel 1	Buff Sel 0	PD0	Control byte (PD0=1)
DAC8574	DAC8574 Acknowledges								
Master	Repeated Start								
Master	1	0	0	1	1	A1	A0	R/ \bar{W}	Read addressing (R/ \bar{W} = 1)
DAC8574	DAC8574 Acknowledges								
DAC8574	PD1	PD2	1	1	1	1	1	1	Read power down byte
Master	Master Acknowledges								
DAC8574	D15	D14	D13	D12	D11	D10	D9	D8	Reading data word, high byte
Master	Master Acknowledges								
DAC8574	D7	D6	D5	D4	D3	D2	D1	D0	Reading data word, low byte
Master	Master Not Acknowledges								Master signal end of read
Master	Stop or Repeated Start ⁽¹⁾								Done

(1) Use repeated start to secure bus operation and loop back to the stage of write addressing for next Write.

Master Receiver Reading From a Slave Transmitter (DAC8574) in HS-Mode

When reading data to the DAC8574 in HS-MODE, the master begins to transmit, what is called the *HS-Master Code* (0000 1XXX) in F/S-mode. No device is allowed to acknowledge the *HS-Master Code*, so the *HS-Master Code* is followed by a NOT acknowledge.

The Master then *switches* to HS-mode and issues a REPEATED START condition, followed by the address byte (with $R/\overline{W} = 0$) after which the DAC8574 acknowledges by pulling SDA low. This address byte is usually followed by the control byte, which is also acknowledged by the DAC8574.

Then there is a REPEATED START condition initiated by the master and the address is resent with ($R/\overline{W} = 1$). This is acknowledged by the DAC8574, indicating that it is prepared to transmit data. Two or Three bytes of data are then read back from the DAC8574, depending on the (PD0-Bit). The value of *Buff-Sel1* and *Buff-Sel0* determines, which channel data is read back. A STOP condition follows.

With the (PD0-Bit = 0) the DAC8574 transmits 2 bytes of data, *HIGH-BYTE* followed by *LOW-BYTE* (refer to Table 7 HS-Mode Readback Sequence).

With the (PD0-Bit = 1) the DAC8574 transmits 3 bytes of data, *POWER-DOWN-BYTE* followed by the *HIGH-BYTE* followed by the *LOW-BYTE* (refer to Table 7 HS-Mode Readback Sequence).

Table 7. Master Receiver Reading Slave Transmitter (DAC8574) in HS-Mode

HS MODE READBACK SEQUENCE									
Transmitter	MSB	6	5	4	3	2	1	LSB	Comment
Master	Start								Begin sequence
Master	0	0	0	0	1	X	X	X	HS Mode Master Code
NONE	Not Acknowledge								No device may acknowledge HS master code
Master	Repeated Start								
Master	1	0	0	1	1	A1	A0	R/\overline{W}	Write addressing ($R/\overline{W}=0$)
DAC8574	DAC8574 Acknowledges								
Master	A3	A2	Load 1	Load 0	X	Buff Sel 1	Buff Sel 0	PD0	Control byte (PD0 = 1)
DAC8574	DAC8574 Acknowledges								
Master	Repeated Start								
Master	1	0	0	1	1	A1	A0	R/\overline{W}	Read addressing ($R/\overline{W}=1$)
DAC8574	DAC8574 Acknowledges								
DAC8574	PD1	PD2	1	1	1	1	1	1	Power-down byte
Master	Master Acknowledges								
DAC8574	D15	D14	D13	D12	D11	D10	D9	D8	Reading data word, high byte
Master	Master Acknowledges								
DAC8574	D7	D6	D5	D4	D3	D2	D1	D0	Reading data word, low byte
Master	Master Not Acknowledges								Master signal end of read
Master	Stop or Repeated Start								Done

Power-On Reset

The DAC8574 contains a power-on-reset circuit that controls the output voltage during power up. On power up, the DAC register is filled with zeros and the output voltage is 0 V; it remains there until a valid write sequence is made to the DAC. This is useful in applications where it is important to know the state of the output of the DAC while it is in the process of powering up. No device pin should be brought high before supply is applied.

Power-Down Modes

The DAC8574 contains four separate power-down modes of operation. The modes are programmable via two most significant bits of the MSB byte, while (CTRL[0] = PD0 = 1). Table 8 shows how the state of these bits correspond to the mode of operation of the device.

Table 8. Power-Down Modes of Operation for the DAC8574

CTRL[0]	MSB[7]	MSB[6]	OPERATING MODE
1	0	0	High Impedance Output
1	0	1	1 kΩ to GND
1	1	0	100 kΩ to GND
1	1	1	High Impedance

When (CTRL[0] = PD0 = 0), the device works normally with its normal power consumption of 250 μ A at 5 V per channel. However, for the three power-down modes, the supply current falls to 200 nA at 5 V (50 nA at 3 V). Not only does the supply current fall but also the output stage is also internally switched from the output of the amplifier to a resistor network of known values. This has the advantage that the output impedance of the device is known while in power-down mode. There are three different options: The output is connected internally to GND through a 1-k Ω resistor, a 100 k Ω resistor or left open-circuit (high impedance). The output stage is illustrated in Figure 55.

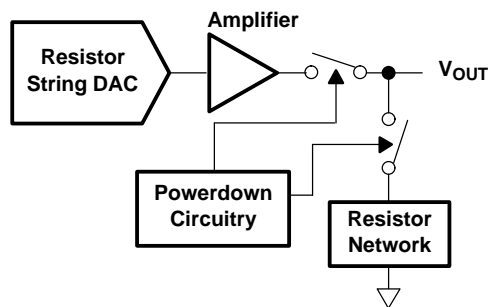

Figure 55. Output Stage During Power Down

All linear circuitry is shut down when the power-down mode is activated. However, the contents of the DAC register are unaffected when in power-down. The time to exit power down is typically 2.5 μ s for $V_{DD} = 5$ V and 5 μ s for $V_{DD} = 3$ V. (See the Typical Curves section for additional information.)

The DAC8574 offers a flexible power-down interface based on channel register operation. A channel consists of a single 16-bit DAC with power-down circuitry, a temporary storage register (TR) and a DAC register (DR). TR and DR are both 18 bits wide. Two MSBs represent the power-down condition and the 16 LSBs represent data for TR and DR. By using bits 17 and 18 of TR and DR, a power-down condition can be temporarily stored and used just like data. Internal circuits ensure that MSB[7] and MSB[6] get transferred to TR[17] and TR[16] (DR[17] and DR[16]) when the power-down flag (CTRL[0] = PD0) is set. Therefore, DAC8574 treats power-down conditions like data and all the operational modes are still valid for power down. It is possible to broadcast a power-down condition to all the DAC8574s in the system, or it is possible to simultaneously power down a channel while updating data on other channels.

CURRENT CONSUMPTION

The DAC8574 typically consumes 225 μA at $V_{\text{DD}} = 5\text{ V}$ and 200 μA at $V_{\text{DD}} = 3\text{ V}$ for each active channel, including reference current consumption. Additional current consumption can occur at the digital inputs if $V_{\text{IH}} \ll V_{\text{DD}}$. For most efficient power operation, CMOS logic levels are recommended at the digital inputs to the DAC. In power-down mode, typical current consumption is 200 nA. A delay time of 10 to 20 ms after a power-down command is issued to the DAC is typically sufficient for the power-down current to drop below 10 μA .

DRIVING RESISTIVE AND CAPACITIVE LOADS

The DAC8574 output stage is capable of driving loads of up to 1000 pF while remaining stable. Within the offset and gain error margins, the DAC8574 can operate rail-to-rail when driving a capacitive load. Resistive loads of 2 k Ω can be driven by the DAC8574 while achieving very good load regulation. Load regulation error increases as the output voltage approaches each rail. When the outputs of the DAC are driven to the positive rail under resistive loading, the PMOS transistor of each Class-AB output stage can enter into the linear region. When this occurs, the added IR voltage drop deteriorates the linearity performance of the DAC. This only occurs within approximately the top 20 mV of the DAC's digital input-to-voltage output transfer characteristic. The reference voltage applied to the DAC8574 may be reduced below the supply voltage applied to V_{DD} in order to eliminate this condition if good linearity is a requirement at full scale (under resistive loading conditions).

CROSSTALK AND AC PERFORMANCE

The DAC8574 architecture uses separate resistor strings for each DAC channel in order to achieve ultra-low crosstalk performance. DC crosstalk seen at one channel during a full-scale change on the neighboring channel is typically less than 0.5 LSBs. The ac crosstalk measured (for a full-scale, 1 kHz sine wave output generated at one channel, and measured at the remaining output channel) is typically under -100 dB . In addition, the DAC8574 can achieve typical ac performance of 96 dB signal-to-noise ratio (SNR) and 65 dB total harmonic distortion (THD), making the DAC8574 a solid choice for applications requiring high SNR at output frequencies at or below 4 kHz.

OUTPUT VOLTAGE STABILITY

The DAC8574 exhibits excellent temperature stability of $\pm 3\text{ ppm}/^\circ\text{C}$ typical output voltage drift over the specified temperature range of the device. This enables the output voltage of each channel to stay within a $\pm 25\text{ }\mu\text{V}$ window for a $\pm 1^\circ\text{C}$ ambient temperature change. Good power-supply rejection ratio (PSRR) performance reduces supply noise present on V_{DD} from appearing at the outputs to well below 10 μV -s. Combined with good dc noise performance and true 16-bit differential linearity, the DAC8574 becomes a perfect choice for closed-loop control applications.

SETTLING TIME AND OUTPUT GLITCH PERFORMANCE

Settling time to within the 16-bit accurate range of the DAC8574 is achievable within 10 μs for a full-scale code change at the input. Worst case settling times between consecutive code changes is typically less than 2 μs . The high-speed serial interface of the DAC8574 is designed in order to support up to 188ksps update rate. For full-scale output swings, the output stage of each DAC8574 channel typically exhibits less than 100 mV of overshoot and undershoot when driving a 200 pF capacitive load. Code-to-code change glitches are extremely low ($\sim 10\text{ }\mu\text{V}$) given that the code-to-code transition does not cross an $N \times 4096$ code boundary. Due to internal segmentation of the DAC8574, code-to-code glitches occur at each crossing of an $N \times 4096$ code boundary. These glitches can approach 100mVs for $N = 15$, but settle out within $\sim 2\text{ }\mu\text{s}$.

APPLICATION INFORMATION

The following sections give example circuits and tips for using the DAC8574 in various applications. For more information, contact your local TI representative, or visit the Texas Instruments website at <http://www.ti.com>.

BASIC CONNECTIONS

For many applications, connecting the DAC8574 is extremely simple. A basic connection diagram for the DAC8574 is shown in Figure 56. The 0.1 μF bypass capacitors help provide the momentary bursts of extra current needed from the supplies.

APPLICATION INFORMATION (continued)

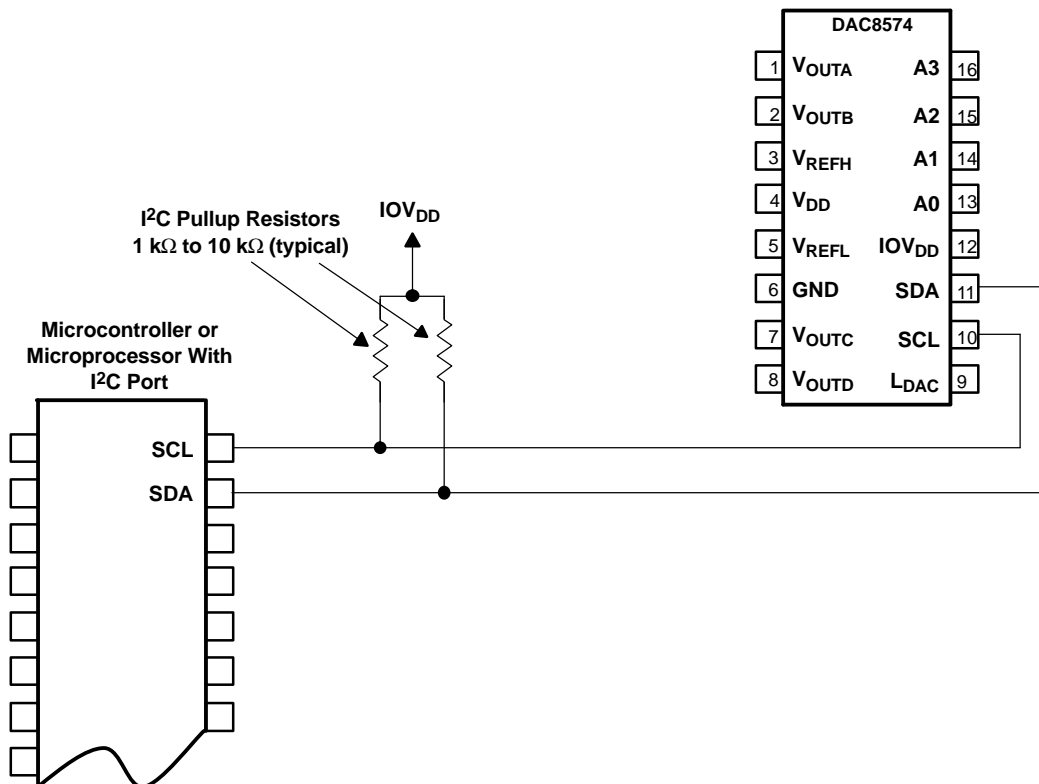

NOTE: DAC8574 power and input/output connections are omitted for clarity, except I²C Inputs.

Figure 56. Typical DAC8574 Connections

The DAC8574 interfaces directly to standard mode, fast mode and high-speed mode I²C controllers. Any microcontroller's I²C peripheral, including master-only and non-multiple-master I²C peripherals, work with the DAC8574. The DAC8574 does not perform clock-stretching (i.e., it never pulls the clock line low), so it is not necessary to provide for this unless other devices are on the same I²C bus.

Pullup resistors are necessary on both the SDA and SCL lines because I²C bus drivers are open-drain. The size of these resistors depend on the bus operating speed and capacitance on the bus lines. Higher-value resistors consume less power, but increase the transition times on the bus, limiting the bus speed. Lower-value resistors allow higher speed at the expense of higher power consumption. Long bus lines have higher capacitance and require smaller pullup resistors to compensate. If the pullup resistors are too small the bus drivers may not be able to pull the bus line low.

USING GPIO PORTS FOR I²C

Most microcontrollers have programmable input/output pins that can be set in software to act as inputs or outputs. If an I²C controller is not available, the DAC8574 can be connected to GPIO pins, and the I²C bus protocol simulated, or bit-banged, in software. An example of this for a single DAC8574 is shown in Figure 57.

APPLICATION INFORMATION (continued)

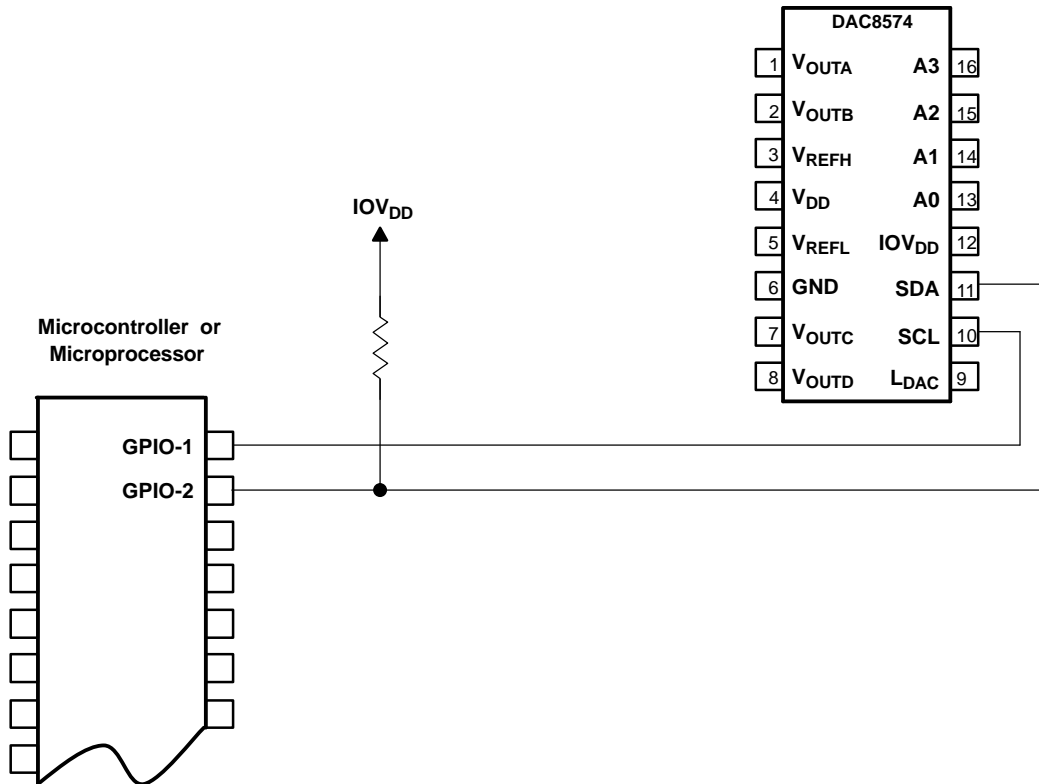

NOTE: DAC8574 power and input/output connections are omitted for clarity, except I²C inputs.

Figure 57. Using GPIO With a Single DAC8574

Bit-banging I²C with GPIO pins can be done by setting the GPIO line to zero and toggling it between input and output modes to apply the proper bus states. To drive the line low, the pin is set to output a zero; to let the line go high, the pin is set to input. When the pin is set to input, the state of the pin can be read; if another device is pulling the line low, this reads as a zero in the port's input register.

Note that no pullup resistor is shown on the SCL line. In this simple case the resistor is not needed. The microcontroller can simply leave the line on output, and set it to one or zero as appropriate. It can do this because the DAC8574 never drives its clock line low. This technique can also be used with multiple devices, and has the advantage of lower current consumption due to the absence of a resistive pullup.

If there are any devices on the bus that may drive their clock lines low, the above method should not be used. The SCL line should be high-Z or zero, and a pullup resistor provided as usual. Note also that this cannot be done on the SDA line in any case, because the DAC8574 drives the SDA line low from time to time, as all I²C devices do.

Some microcontrollers have selectable strong pullup circuits built in to their GPIO ports. In some cases, these can be switched on and used in place of an external pullup resistor. Weak pullups are also provided on some microcontrollers, but usually these are too weak for I²C communication. Test any circuit before committing it to production.

APPLICATION INFORMATION (continued)

USING REF02 AS A POWER SUPPLY FOR DAC8574

Due to the extremely low supply current required by the DAC8574, a possible configuration is to use a REF02 +5 V precision voltage reference to supply the required voltage to the DAC8574's supply input as well as the reference input, as shown in Figure 58. This is especially useful if the power supply is quite noisy or if the system supply voltages are at some value other than 5 V. The REF02 outputs a steady supply voltage for the DAC8574. If the REF02 is used, the current it needs to supply to the DAC8574 is 950 μ A typical and 1600 μ A max for $V_{DD} = 5$ V. When a DAC output is loaded, the REF02 also needs to supply the current to the load. The total typical current required (with a 5-k Ω load on a single DAC output) is:

$$950 \mu\text{A} + (5 \text{ V} / 5 \text{ k}\Omega) = 1.950 \text{ mA}$$

The load regulation of the REF02 is typically 0.005%/mA, which results in an error of 488 μ V for 1.950-mA of current drawn from it. This corresponds to a 6.4 LSB error for a 0-V to 5-V output range.

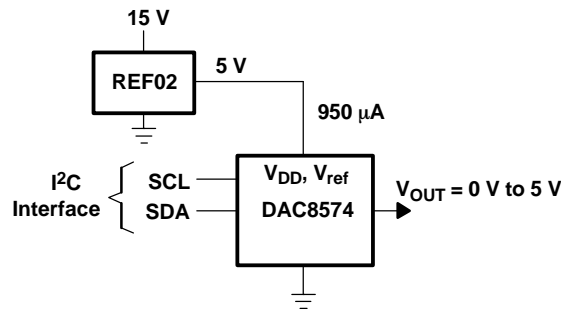

Figure 58. REF02 Power Supply

REF3040 can also be used to generate a 4.096-V reference from a 5-V supply.

GENERATING $\pm 5\text{-V}$, $\pm 10\text{-V}$, and $\pm 12\text{-V}$ OUTPUTS FOR PRECISION INDUSTRIAL CONTROL

Industrial control applications can require multiple feedback loops consisting of sensors, ADCs, MCUs, DACs, and actuators. Loop accuracy and loop speed are the two important parameters of such control loops.

Loop Accuracy:

In a control loop, the ADC has to be accurate. Offset, gain, and the integral linearity errors of the DAC are not factors in determining the accuracy of the loop. As long as a voltage exists in the transfer curve of a monotonic DAC, the loop can find it and settle to it. On the other hand, DAC resolution and differential linearity do determine the loop accuracy, because each DAC step determines the minimum incremental change the loop can generate. A DNL error less than -1 LSB (non-monotonicity) can create loop instability. A DNL error greater than $+1$ LSB implies unnecessarily large voltage steps, and missed voltage targets. With high DNL errors, the loop loses its stability, resolution, and accuracy. Offering 16-bit assured monotonicity and ± 0.25 LSB typical DNL error, 85XX DACs are great choices for precision control loops.

Loop Speed:

Many factors determine control loop speed. Typically, the ADC's conversion time, and the MCU's computation time are the two major factors that dominate the time constant of the loop. DAC settling time is rarely a dominant factor because ADC conversion times usually exceed DAC conversion times. DAC offset, gain, and linearity errors can slow the loop down only during the start-up. Once the loop reaches its steady-state operation, these errors do not affect loop speed any further. Depending on the ringing characteristics of the loop's transfer function, DAC glitches can also slow the loop down. With its 188 kbps maximum data update rate, DAC8574 can support high-speed control loops.

Generating Industrial Voltage Ranges:

For control loop applications, DAC gain and offset errors are not important parameters. This could be exploited to lower trim and calibration costs in a high-voltage control circuit design. Using a quad op amp (OPA4130), a voltage reference (REF3040) and a quad 12-bit DAC (DAC7574), the DAC8574 can generate the wide voltage swings required by the control loop.

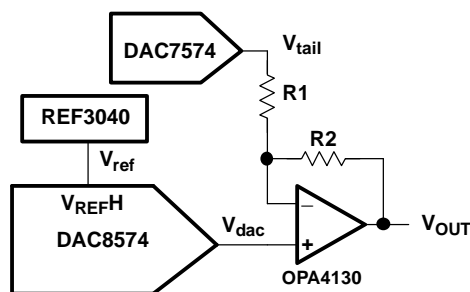

Figure 59. Low-cost, Wide-swing Voltage Generator for Control Loop Applications

The output voltage of the configuration is given by:

$$V_{\text{out}} = V_{\text{ref}} \left(\frac{R_2}{R_1} + 1 \right) \frac{D_{\text{in}}}{65536} - V_{\text{tail}} \frac{R_2}{R_1}$$

Fixed R_1 and R_2 resistors can be used to coarsely set the gain required in the first term of the equation. Once R_2 and R_1 set the gain properly, a DAC7574 could be used to set the required offset voltages. Residual errors are not an issue for loop accuracy because offset and gain errors could be tolerated.

For $\pm 5\text{-V}$ operation: $R_1 = 10 \text{ k}\Omega$, $R_2 = 15 \text{ k}\Omega$, $V_{\text{tail}} = 3.33 \text{ V}$, $V_{\text{ref}} = 4.096 \text{ V}$

For $\pm 10\text{-V}$ operation: $R_1 = 10 \text{ k}\Omega$, $R_2 = 39 \text{ k}\Omega$, $V_{\text{tail}} = 2.56 \text{ V}$, $V_{\text{ref}} = 4.096 \text{ V}$

For $\pm 12\text{-V}$ operation: $R_1 = 10 \text{ k}\Omega$, $R_2 = 49 \text{ k}\Omega$, $V_{\text{tail}} = 2.45 \text{ V}$, $V_{\text{ref}} = 4.096 \text{ V}$

Digital Correction of DAC Errors

For open-loop applications requiring improved accuracy, offset and gain errors of the DAC8574 can be measured and digitally corrected. To avoid waveform clipping, it is recommended to make the offset and gain error measurements at codes 1024 and 64512 respectively. The total error of DAC8574 is dominated by gain and offset errors, and it can be improved by an order of magnitude using the following digital correction:

$$DIN = DDIN - OE - (FSE - OE) \times (DDIN - 1024) \div 64512$$

where:

DIN = Digital input code to the DAC after offset and gain correction

DDIN = Digital input code to the DAC before offset and gain correction

OE = measured DAC error at code 1024 (in LSBs)

FSE = measured DAC error at code 64512 (in LSBs)

If division operation is not feasible, FSE measurement can be done at code 32768 instead of code 64512. Division by 32768 implies a 15-bit arithmetic right shift. Improvements to the transfer curve are still significant.

DAC8574 integral linearity error is well within ± 5 mV, therefore it only has a secondary effect on total DAC error. Using piece-wise linear approximation, and non-volatile memory, integral linearity errors of DAC8574 can also be digitally corrected. Consult TI applications engineering for details.

64 Channel Operation

DAC8574 is designed to facilitate high channel count operation. DAC8574 supports multichannel simultaneous synchronous update up to 16 DAC8574 devices for up to 64 channels on a single I²C bus. Working with multiple DAC8574s, single channel DAC8571s can be used on the same bus to obtain odd channel counts, or quad channel DAC8574s can be used if some channels only need 12 bits of resolution.

Data or power down can be loaded to temporary registers of each channel serially and a single broadcast operation can be used to update all channels of all devices simultaneously with previously stored data or power-down condition. Another feature useful for system start-up or system shut-down is to broadcast the same data (or power-down condition) to all channels with a single broadcast command.

All multichannel system updates are performed at the falling edge of the acknowledge signal that follows the least significant byte.

The 64-channel operation requires 6-bit address decoding. 4-bit address decoding is used to support 16 DAC8574 devices on the same bus and 2-bit address decoding is used to select one out of four channels of a DAC8574. 4-bit address decoding that selects one out of 16 DAC8574 devices is done as follows: To save I²C address space, 2-bits (A0 and A1) are used for I²C address decoding, and two additional bits (A2 and A3) are used for local address decoding. Up to 4 DAC8574 devices using the same I²C address can be connected on the same I²C bus. These four devices with the same I²C address can be locally decoded using A2 and A3 pins. If multiple devices use the same I²C address, multiple devices acknowledge at the same time. However, in order for a particular device to respond to a command, the states of the first two bits of the control word C7 and C6 must match the states of A3 and A2 pins. Four devices per I²C address and four distinct I²C addresses enable 16 devices on the same bus.

The four address pins should be set at power-up, and address bits must be set to match a particular device's address pins. To decode up to 16 DAC8574 devices, the logic states of A3, A2, A1, A0 address pins and C7, C6, A1, A0 address bits should be set as shown in Table 9.

Table 9. 64 Channel Address Decoding

DEV #	A3 PIN	C7 BIT	A2 PIN	C6 BIT	A1 PIN	A1 BIT	A0 PIN	A0 BIT
1	0	0	0	0	0	0	0	0
2	0	0	0	0	0	0	1	1
3	0	0	0	0	1	1	0	0
4	0	0	0	0	1	1	1	1
5	0	0	1	1	0	0	0	0
6	0	0	1	1	0	0	1	1
7	0	0	1	1	1	1	0	0
8	0	0	1	1	1	1	1	1
9	1	1	0	0	0	0	0	0
10	1	1	0	0	0	0	1	1
11	1	1	0	0	1	1	0	0
12	1	1	0	0	1	1	1	1
13	1	1	1	1	0	0	0	0
14	1	1	1	1	0	0	1	1
15	1	1	1	1	1	1	0	0
16	1	1	1	1	1	1	1	1

Once a DAC8574 device is selected, channel select bits C2 and C1 can select a particular channel. Overall, I²C address bits A1, A0, control bits C7, C6, C2 and C1 form the 6-bit address required to select one channel out of 64 possibilities.

Broadcast operation is supported for both I²C addressing and for extended addressing. A broadcast address (10010000) makes all DAC8574 devices listen, regardless of the states of A0 and A1 pins. Also, a broadcast command (C5 = C4 = 1) makes all devices listen, regardless of the states of A2 and A3 pins. The same broadcast command (C5 = C4 = 1) also selects all channels for a given device, regardless of the states of channel select bits. Thus, a global broadcast message that simultaneously updates up to 64 channels uses 10010000 as I²C address and has (C5 = C4 = 1) in the control word.

Examples

I²C Standard and Fast Mode Examples (A0, A1, A2, A3 and LDAC pins tied to GND):

EXAMPLE 1: WRITE 1/4 SCALE TO CHANNEL A									
START	ADDRESS [7...0]	ACK	C [7...0]	ACK	M [7...0]	ACK	L [7...0]	ACK	STOP
	1001 1000		0001 0000		0100 0000		0000 0000		
Previous VoutA output voltage is valid								VoutA = 1.25 V	
EXAMPLE 2: WRITE 1/2 SCALE TO CHANNEL B									
START	ADDRESS [7...0]	ACK	C [7...0]	ACK	M [7...0]	ACK	L [7...0]	ACK	STOP
	1001 1000		0001 0010		1000 0000		0000 0000		
Previous VoutB output voltage is valid								VoutB = 2.50 V	
EXAMPLE 3: WRITE 3/4 SCALE TO CHANNEL C									
START	ADDRESS [7...0]	ACK	C [7...0]	ACK	M [7...0]	ACK	L [7...0]	ACK	STOP
	1001 1000		0001 0100		1100 0000		0000 0000		
Previous VoutC output voltage is valid								VoutC = 3.75 V	

EXAMPLE 4: WRITE 4/4 SCALE TO CHANNEL D									
	ADDRESS [7...0]		C [7...0]		M [7...0]		L [7...0]		
START	1001 1000	ACK	0001 0110	ACK	1111 1111	ACK	1111 1111	ACK	STOP
Previous VoutD output voltage is valid								VoutB = 5.0 V	
EXAMPLE 5: Power-Down Channel A, With Hi-Z Output									
	ADDRESS [7...0]		C [7...0]		M [7...0]		L [7...0]		
START	1001 1000	ACK	0001 0001	ACK	0000 0000	ACK	0000 0000	ACK	STOP
Previous VoutA output voltage is valid								VoutA = Hi-Z	
EXAMPLE 6: Power-Down Channel B, With Hi-Z Output									
	ADDRESS [7...0]		C [7...0]		M [7...0]		L [7...0]		
START	1001 1000	ACK	0001 0011	ACK	0000 0000	ACK	0000 0000	ACK	STOP
Previous VoutB output voltage is valid								VoutB = Hi-Z	
EXAMPLE 7: Power-Down Channel C, With Hi-Z Output									
	ADDRESS [7...0]		C [7...0]		M [7...0]		L [7...0]		
START	1001 1000	ACK	0001 0101	ACK	0000 0000	ACK	0000 0000	ACK	STOP
Previous VoutC output voltage is valid								VoutC = Hi-Z	
EXAMPLE 8: Power-Down Channel D, With Hi-Z Output									
	ADDRESS [7...0]		C [7...0]		M [7...0]		L [7...0]		
START	1001 1000	ACK	0001 0111	ACK	0000 0000	ACK	0000 0000	ACK	STOP
Previous VoutD output voltage is valid								VoutD = Hi-Z	
EXAMPLE 9: Power-Down Channel D, With 1 kΩ Output Impedance to Ground									
	ADDRESS [7...0]		C [7...0]		M [7...0]		L [7...0]		
START	1001 1000	ACK	0001 0111	ACK	0100 0000	ACK	0000 0000	ACK	STOP
Previous VoutA output voltage is valid								VoutD = 0 V	
EXAMPLE 10: Power-Down Channel D, With 100 kΩ Output Impedance to Ground									
	ADDRESS [7...0]		C [7...0]		M [7...0]		L [7...0]		
START	1001 1000	ACK	0001 0111	ACK	1000 0000	ACK	0000 0000	ACK	STOP
Previous VoutD output voltage is valid								VoutD = 0 V	

EXAMPLE 11: Simultaneous Update of All Channels									
Write 4/4 Scale, 4/3 Scale, 2/4 Scale, and 1/4 Scale Data to Temporary Registers of Channels A, B, C, D Serially, and Update all DACs Simultaneously									
	ADDRESS [7...0]		C [7...0]		M [7...0]		L [7...0]		
START	1001 1000	ACK	0000 0000	ACK	1111 1111	ACK	1111 1111	ACK	STOP
Previous DAC output voltages are valid for all channels									
START	1001 1000	ACK	0000 0010	ACK	1100 0000	ACK	0000 0000	ACK	
Previous DAC output voltages are valid for all channels									
START	1001 1000	ACK	0000 0100	ACK	1000 0000	ACK	0000 0000	ACK	
Previous DAC output voltages are valid for all channels									
START	1001 1000	ACK	0010 0110	ACK	0100 0000	ACK	0000 0000	ACK	
Previous DAC output voltages are valid for all channels								New data is valid	
EXAMPLE 12: Simultaneous Update Channels A, B, C and Power-Down of Channel D at The End of The Fourth Cycle									
Write 4/4 Scale, 3/4 Scale, 2/4 Scale, and Power-Down (Hi-Z) Data to Temporary Registers of Channels A, B, C, D Serially, and Update Simultaneously									
	ADDRESS [7...0]		C [7...0]		M [7...0]		L [7...0]		
START	1001 1000	ACK	0000 0000	ACK	1111 1111	ACK	1111 1111	ACK	STOP
Previous DAC output voltages are valid for all channels									
START	1001 1000	ACK	0000 0010	ACK	1100 0000	ACK	0000 0000	ACK	STOP
Previous DAC output voltages are valid for all channels									
START	1001 1000	ACK	0000 0100	ACK	1000 0000	ACK	0000 0000	ACK	STOP
Previous DAC output voltages are valid for all channels									
START	1001 1000	ACK	0010 0111	ACK	0000 0000	ACK	0000 0000	ACK	STOP
Previous DAC output voltages are valid for all channels								New data is valid	
EXAMPLE 13: Store data and wait for update command (Write codes 128, 256, 512, and 1024 to temporary registers of channels A, B, C, D)									
Write 4/4 Scale, 3/4 Scale, 2/4 Scale, and 1/4 Scale Data to Temporary Registers of Channels A, B, C, D Serially, and Update all DACs Simultaneously									
	ADDRESS [7...0]		C [7...0]		M [7...0]		L [7...0]		
START	1001 1000	ACK	0000 0000	ACK	0000 0000	ACK	1000 0000	ACK	STOP
Previous DAC output voltages are valid for all channels									
START	1001 1000	ACK	0000 0010	ACK	0000 0001	ACK	0000 0000	ACK	STOP
Previous DAC output voltages are valid for all channels									
START	1001 1000	ACK	0000 0100	ACK	0000 0010	ACK	0000 0000	ACK	STOP
Previous DAC output voltages are valid for all channels									
START	1001 1000	ACK	0010 0110	ACK	0100 0100	ACK	0000 0000	ACK	STOP
Previous DAC output voltages are valid for all channels									

EXAMPLE 14: Broadcast update command. All channels of all DAC8574s update with previously stored temporary register data.									
START	ADDRESS [7...0] 1001 0000	ACK	C [7...0] 0011 0000	ACK	M [7...0] XXXX XXXX	ACK	L [7...0] XXXX XXXX	ACK	STOP
Previous DAC output voltages are valid for all channels, all DAC8574s								New data is valid	
EXAMPLE 15: Broadcast Data. All channels of all DAC8574s get set to code 7.									
START	ADDRESS [7...0] 1001 0000	ACK	C [7...0] 0011 0000	ACK	M [7...0] 0000 0000	ACK	L [7...0] 0000 0111	ACK	STOP
Previous DAC output voltages are valid for all channels, all DAC8574s								All Vouts = 7 x 76 μV	
EXAMPLE 16: Broadcast Power-Down. All channels of all DAC8574s get powered down with output impedance of 1 kΩ to ground.									
START	ADDRESS [7...0] 1001 0000	ACK	C [7...0] 0011 0001	ACK	M [7...0] 0100 0000	ACK	L [7...0] 0000 0000	ACK	STOP
Previous DAC output voltages are valid for all channels, all DAC8574s								All Vouts = GND	

I²C Read-back Examples (A0, A1, A2, A3 and LDAC pins tied to GND):

EXAMPLE 17: Read back channel A power-down bits and 16-bit channel A data. V denotes valid logic.							
START	ADDRESS [7...0] 1001 1000	ACK	C [7...0] 0001 0001	ACK	REPEATED START	ADDRESS 1001 1001	ACK
PWD [7...0] VV11 1111	MASTER ACK	MSB [7...0] VVVV VVVV	MASTER ACK	LSB [7...0] VVVV VVVV	MASTER NOT ACK		
EXAMPLE 18: Read back channel B power-down bits and 16-bit channel B data. V denotes valid logic.							
START	ADDRESS [7...0] 1001 1000	ACK	C [7...0] 0001 0011	ACK	REPEATED START	ADDRESS 1001 1001	ACK
PWD [7...0] VV11 1111	MASTER ACK	MSB [7...0] VVVV VVVV	MASTER ACK	LSB [7...0] VVVV VVVV	MASTER NOT ACK		
EXAMPLE 19: Read back channel C power-down bits and 16-bit channel C data. V denotes valid logic.							
START	ADDRESS [7...0] 1001 1000	ACK	C [7...0] 0001 0101	ACK	REPEATED START	ADDRESS 1001 1001	ACK
PWD [7...0] VV11 1111	MASTER ACK	MSB [7...0] VVVV VVVV	MASTER ACK	LSB [7...0] VVVV VVVV	MASTER NOT ACK		
EXAMPLE 20: Read back channel D power-down bits and 16-bit channel D data. V denotes valid logic.							
START	ADDRESS [7...0] 1001 1000	ACK	C [7...0] 0001 0111	ACK	REPEATED START	ADDRESS 1001 1001	ACK
PWD [7...0] VV11 1111	MASTER ACK	MSB [7...0] VVVV VVVV	MASTER ACK	LSB [7...0] VVVV VVVV	MASTER NOT ACK		
EXAMPLE 21: Read back 16-bit channel D data only. V denotes valid logic.							
START	ADDRESS [7...0] 1001 1000	ACK	C [7...0] 0001 0110	ACK	REPEATED START	ADDRESS 1001 1001	ACK
MSB [7...0] VVVV VVVV	MASTER ACK	LSB [7...0] VVVV VVVV	MASTER NOT ACK				

I²C High Speed Examples (A0, A1, A2, A3 and LDAC pins tied to GND):

EXAMPLE 22: Ramp generation on channel D (Up to Code 7 is shown)							
START	HS Master Code	NOT ACK	REPEATED START	ADDRESS	ACK	C [7 ... 0]	ACK
	0000 1000			10011 0000		0001 0110	
Previous VoutD voltage valid							
MSB [7...0]		LSB [7...0]		MSB [7...0]		LSB [7...0]	
0000 0000	ACK	0000 0000	ACK	0000 0000	ACK	0000 0001	ACK
Previous VoutD voltage valid		VoutD = 0 V					VoutD = 76 μV
MSB [7...0]		LSB [7...0]		MSB [7...0]		LSB [7...0]	
0000 0000	ACK	0000 0010	ACK	0000 0000	ACK	0000 0011	ACK
VoutD = 76 μV		VoutD = 2 x 76 μV					VoutD = 3 x 76 μV
MSB [7...0]		LSB [7...0]		MSB [7...0]		LSB [7...0]	
0000 0000	ACK	0000 0100	ACK	0000 0000	ACK	0000 0101	ACK
VoutD = 3 x 76 μV		VoutD = 4 x 76 μV					VoutD = 5 x 76 μV
MSB [7...0]		LSB [7...0]		MSB [7...0]		LSB [7...0]	
0000 0000	ACK	0000 0110	ACK	0000 0000	ACK	0000 0111	ACK
VoutD = 5 x 76 μV		VoutD = 6 x 76 μV					VoutD = 7 x 76 μV

LAYOUT

A precision analog component requires careful layout, adequate bypassing, and clean, well-regulated power supplies.

The power applied to V_{DD} should be well-regulated and low noise. Switching power supplies and dc/dc converters often have high-frequency glitches or spikes riding on the output voltage. In addition, digital components can create similar high-frequency spikes as their internal logic switches states. This noise can easily couple into the DAC output voltage through various paths between the power connections and analog output.

As with the GND connection, V_{DD} should be connected to a positive power-supply plane or trace that is separate from the connection for digital logic until they are connected at the power-entry point. In addition, a 1 μF to 10 μF capacitor in parallel with a 0.1 μF bypass capacitor is strongly recommended. In some situations, additional bypassing may be required, such as a 100 μF electrolytic capacitor or even a Pi filter made up of inductors and capacitors—all designed to essentially low-pass filter the –5 V supply, removing the high-frequency noise.

PACKAGING INFORMATION

Orderable Device	Status (1)	Package Type	Package Drawing	Pins	Package Qty	Eco Plan (2)	Lead/Ball Finish (6)	MSL Peak Temp (3)	Op Temp (°C)	Device Marking (4/5)	Samples
DAC8574IPW	ACTIVE	TSSOP	PW	16	90	Green (RoHS & no Sb/Br)	CU NIPDAU	Level-1-260C-UNLIM	-40 to 105	D8574I	Samples
DAC8574IPWG4	ACTIVE	TSSOP	PW	16	90	Green (RoHS & no Sb/Br)	CU NIPDAU	Level-1-260C-UNLIM	-40 to 105	D8574I	Samples
DAC8574IPWR	ACTIVE	TSSOP	PW	16	2000	Green (RoHS & no Sb/Br)	CU NIPDAU	Level-1-260C-UNLIM	-40 to 105	D8574I	Samples

(1) The marketing status values are defined as follows:

ACTIVE: Product device recommended for new designs.

LIFEBUY: TI has announced that the device will be discontinued, and a lifetime-buy period is in effect.

NRND: Not recommended for new designs. Device is in production to support existing customers, but TI does not recommend using this part in a new design.

PREVIEW: Device has been announced but is not in production. Samples may or may not be available.

OBSOLETE: TI has discontinued the production of the device.

(2) Eco Plan - The planned eco-friendly classification: Pb-Free (RoHS), Pb-Free (RoHS Exempt), or Green (RoHS & no Sb/Br) - please check <http://www.ti.com/productcontent> for the latest availability information and additional product content details.

TBD: The Pb-Free/Green conversion plan has not been defined.

Pb-Free (RoHS): TI's terms "Lead-Free" or "Pb-Free" mean semiconductor products that are compatible with the current RoHS requirements for all 6 substances, including the requirement that lead not exceed 0.1% by weight in homogeneous materials. Where designed to be soldered at high temperatures, TI Pb-Free products are suitable for use in specified lead-free processes.

Pb-Free (RoHS Exempt): This component has a RoHS exemption for either 1) lead-based flip-chip solder bumps used between the die and package, or 2) lead-based die adhesive used between the die and leadframe. The component is otherwise considered Pb-Free (RoHS compatible) as defined above.

Green (RoHS & no Sb/Br): TI defines "Green" to mean Pb-Free (RoHS compatible), and free of Bromine (Br) and Antimony (Sb) based flame retardants (Br or Sb do not exceed 0.1% by weight in homogeneous material)

(3) MSL, Peak Temp. - The Moisture Sensitivity Level rating according to the JEDEC industry standard classifications, and peak solder temperature.

(4) There may be additional marking, which relates to the logo, the lot trace code information, or the environmental category on the device.

(5) Multiple Device Markings will be inside parentheses. Only one Device Marking contained in parentheses and separated by a "~" will appear on a device. If a line is indented then it is a continuation of the previous line and the two combined represent the entire Device Marking for that device.

(6) Lead/Ball Finish - Orderable Devices may have multiple material finish options. Finish options are separated by a vertical ruled line. Lead/Ball Finish values may wrap to two lines if the finish value exceeds the maximum column width.

Important Information and Disclaimer: The information provided on this page represents TI's knowledge and belief as of the date that it is provided. TI bases its knowledge and belief on information provided by third parties, and makes no representation or warranty as to the accuracy of such information. Efforts are underway to better integrate information from third parties. TI has taken and

continues to take reasonable steps to provide representative and accurate information but may not have conducted destructive testing or chemical analysis on incoming materials and chemicals. TI and TI suppliers consider certain information to be proprietary, and thus CAS numbers and other limited information may not be available for release.

In no event shall TI's liability arising out of such information exceed the total purchase price of the TI part(s) at issue in this document sold by TI to Customer on an annual basis.

TAPE AND REEL INFORMATION



QUADRANT ASSIGNMENTS FOR PIN 1 ORIENTATION IN TAPE



*All dimensions are nominal

Device	Package Type	Package Drawing	Pins	SPQ	Reel Diameter (mm)	Reel Width W1 (mm)	A0 (mm)	B0 (mm)	K0 (mm)	P1 (mm)	W (mm)	Pin1 Quadrant
DAC8574IPWR	TSSOP	PW	16	2000	330.0	12.4	6.9	5.6	1.6	8.0	12.0	Q1

TAPE AND REEL BOX DIMENSIONS



*All dimensions are nominal

Device	Package Type	Package Drawing	Pins	SPQ	Length (mm)	Width (mm)	Height (mm)
DAC8574IPWR	TSSOP	PW	16	2000	350.0	350.0	43.0

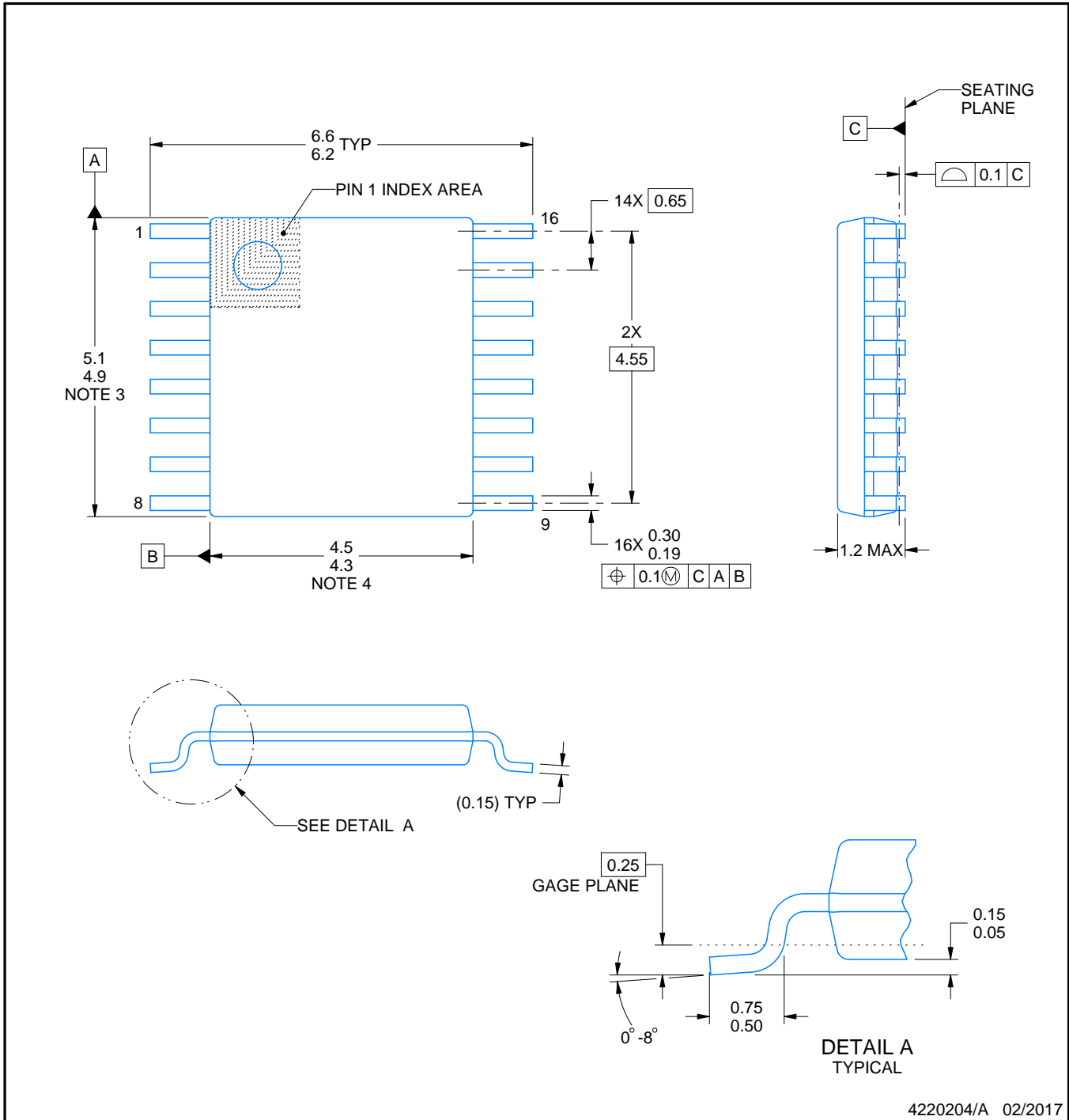
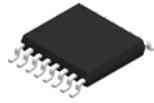

4220204/A 02/2017

NOTES:

1. All linear dimensions are in millimeters. Any dimensions in parenthesis are for reference only. Dimensioning and tolerancing per ASME Y14.5M.
2. This drawing is subject to change without notice.
3. This dimension does not include mold flash, protrusions, or gate burrs. Mold flash, protrusions, or gate burrs shall not exceed 0.15 mm per side.
4. This dimension does not include interlead flash. Interlead flash shall not exceed 0.25 mm per side.
5. Reference JEDEC registration MO-153.

EXAMPLE BOARD LAYOUT

PW0016A

TSSOP - 1.2 mm max height

SMALL OUTLINE PACKAGE

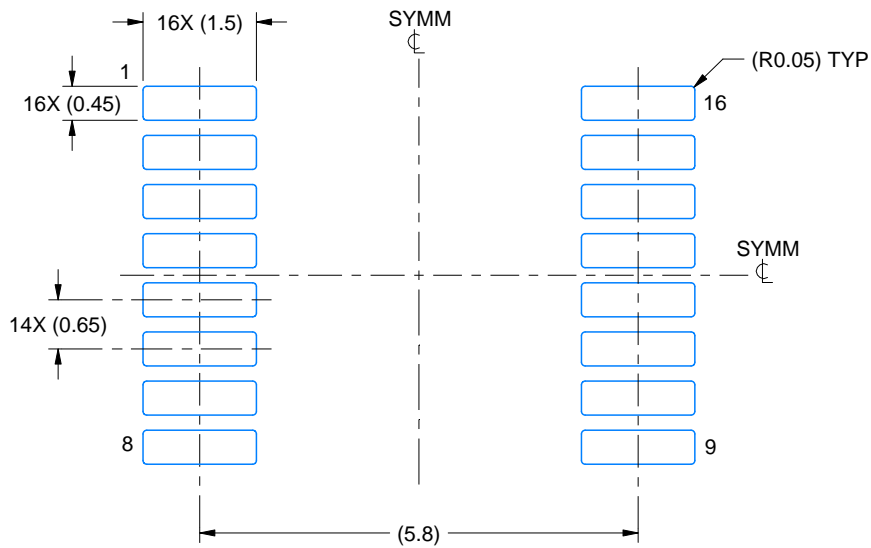

LAND PATTERN EXAMPLE
EXPOSED METAL SHOWN
SCALE: 10X

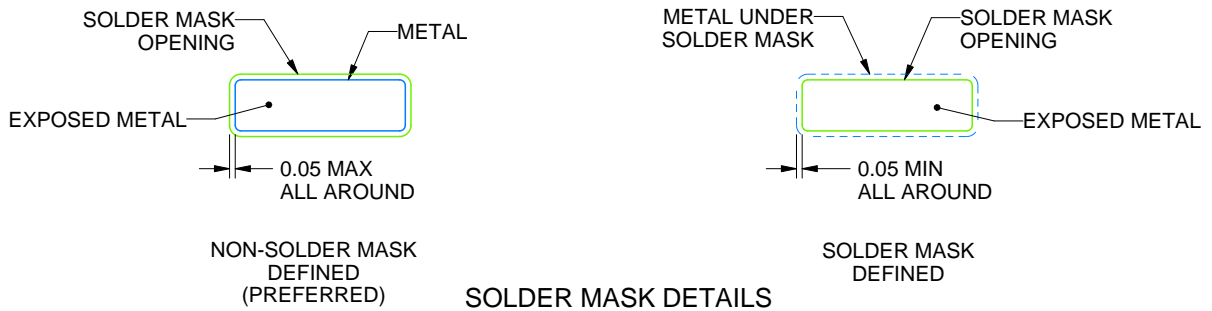

SOLDER MASK DETAILS

4220204/A 02/2017

NOTES: (continued)

- 6. Publication IPC-7351 may have alternate designs.
- 7. Solder mask tolerances between and around signal pads can vary based on board fabrication site.

EXAMPLE STENCIL DESIGN

PW0016A

TSSOP - 1.2 mm max height

SMALL OUTLINE PACKAGE

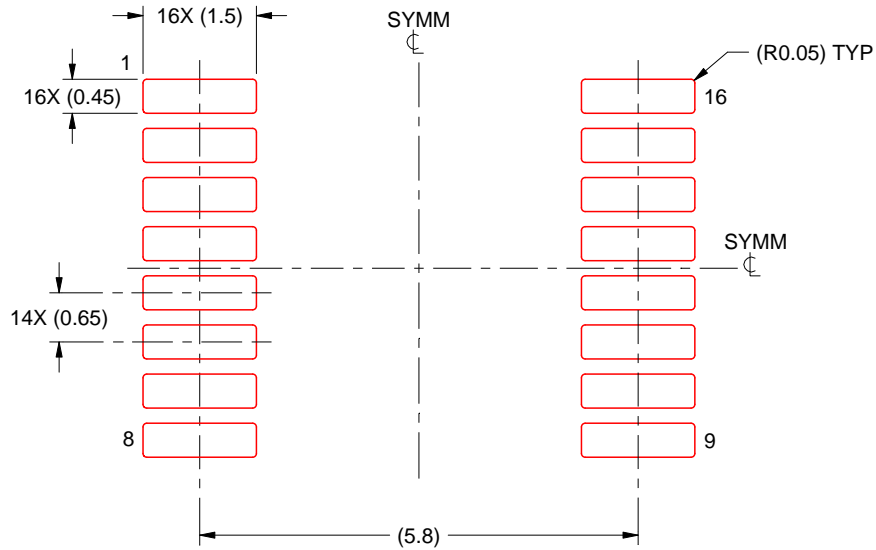

SOLDER PASTE EXAMPLE
BASED ON 0.125 mm THICK STENCIL
SCALE: 10X

4220204/A 02/2017

NOTES: (continued)

8. Laser cutting apertures with trapezoidal walls and rounded corners may offer better paste release. IPC-7525 may have alternate design recommendations.
9. Board assembly site may have different recommendations for stencil design.

IMPORTANT NOTICE AND DISCLAIMER

TI PROVIDES TECHNICAL AND RELIABILITY DATA (INCLUDING DATASHEETS), DESIGN RESOURCES (INCLUDING REFERENCE DESIGNS), APPLICATION OR OTHER DESIGN ADVICE, WEB TOOLS, SAFETY INFORMATION, AND OTHER RESOURCES "AS IS" AND WITH ALL FAULTS, AND DISCLAIMS ALL WARRANTIES, EXPRESS AND IMPLIED, INCLUDING WITHOUT LIMITATION ANY IMPLIED WARRANTIES OF MERCHANTABILITY, FITNESS FOR A PARTICULAR PURPOSE OR NON-INFRINGEMENT OF THIRD PARTY INTELLECTUAL PROPERTY RIGHTS.

These resources are intended for skilled developers designing with TI products. You are solely responsible for (1) selecting the appropriate TI products for your application, (2) designing, validating and testing your application, and (3) ensuring your application meets applicable standards, and any other safety, security, or other requirements. These resources are subject to change without notice. TI grants you permission to use these resources only for development of an application that uses the TI products described in the resource. Other reproduction and display of these resources is prohibited. No license is granted to any other TI intellectual property right or to any third party intellectual property right. TI disclaims responsibility for, and you will fully indemnify TI and its representatives against, any claims, damages, costs, losses, and liabilities arising out of your use of these resources.

TI's products are provided subject to TI's Terms of Sale (www.ti.com/legal/termsofsale.html) or other applicable terms available either on ti.com or provided in conjunction with such TI products. TI's provision of these resources does not expand or otherwise alter TI's applicable warranties or warranty disclaimers for TI products.

Mailing Address: Texas Instruments, Post Office Box 655303, Dallas, Texas 75265
Copyright © 2019, Texas Instruments Incorporated

Looking for pricing, stock, or lifecycle information?

Click below to explore more details on WIN SOURCE:

 [View DAC8574IPWR on WIN SOURCE](#)

 [Texas Instruments](#) Information

Optimize Your Supply Chain with WIN SOURCE Solutions

-  Global Sourcing Solution
-  Obsolete Management
-  Cost Control Management
-  Shortage Management
-  Alternative Solution
-  Excess Inventory Management