



**THE DATASHEET OF  
MSP430F5229IZQER**



## MSP430F522x, MSP430F521x Mixed-Signal Microcontrollers

### 1 Device Overview

#### 1.1 Features

- Dual-Supply Voltage Device
  - Primary Supply (AVCC, DVCC):
    - Powered From External Supply:  
3.6 V Down to 1.8 V
    - Up to 22 General-Purpose I/Os With up to Four External Interrupts
  - Low-Voltage Interface Supply (DVIO):
    - Powered From Separate External Supply:  
1.62 V to 1.98 V
    - Up to 31 General-Purpose I/Os With up to 12 External Interrupts
    - Serial Communications
- Ultra-Low Power Consumption
  - Active Mode (AM):  
All System Clocks Active  
290  $\mu$ A/MHz at 8 MHz, 3.0 V, Flash Program Execution (Typical)  
150  $\mu$ A/MHz at 8 MHz, 3.0 V, RAM Program Execution (Typical)
  - Standby Mode (LPM3):  
Real-Time Clock (RTC) With Crystal, Watchdog, and Supply Supervisor Operational, Full RAM Retention, Fast Wakeup:  
1.9  $\mu$ A at 2.2 V, 2.1  $\mu$ A at 3.0 V (Typical)  
Low-Power Oscillator (VLO), General-Purpose Counter, Watchdog, and Supply Supervisor Operational, Full RAM Retention, Fast Wakeup:  
1.4  $\mu$ A at 3.0 V (Typical)
  - Off Mode (LPM4):  
Full RAM Retention, Supply Supervisor Operational, Fast Wakeup:  
1.1  $\mu$ A at 3.0 V (Typical)
  - Shutdown Mode (LPM4.5):  
0.18  $\mu$ A at 3.0 V (Typical)
- Wake up From Standby Mode in 3.5  $\mu$ s (Typical)
- 16-Bit RISC Architecture, Extended Memory, up to 25-MHz System Clock
- Flexible Power-Management System
  - Fully Integrated LDO With Programmable Regulated Core Supply Voltage
  - Supply Voltage Supervision, Monitoring, and Brownout
- Unified Clock System
  - FLL Control Loop for Frequency Stabilization
  - Low-Power Low-Frequency Internal Clock Source (VLO)
  - Low-Frequency Trimmed Internal Reference Source (REFO)
  - 32-kHz Watch Crystals (XT1)
  - High-Frequency Crystals up to 32 MHz (XT2)
- 16-Bit Timer TA0, Timer\_A With Five Capture/Compare Registers
- 16-Bit Timer TA1, Timer\_A With Three Capture/Compare Registers
- 16-Bit Timer TA2, Timer\_A With Three Capture/Compare Registers
- 16-Bit Timer TB0, Timer\_B With Seven Capture/Compare Shadow Registers
- Two Universal Serial Communication Interfaces
  - USCI\_A0 and USCI\_A1 Each Support:
    - Enhanced UART With Automatic Baud Rate Detection
    - IrDA Encoder and Decoder
    - Synchronous SPI
  - USCI\_B0 and USCI\_B1 Each Support:
    - I<sup>2</sup>C
    - Synchronous SPI
- 10-Bit Analog-to-Digital Converter (ADC) With Internal Reference, Sample-and-Hold
- Comparator
- Hardware Multiplier Supports 32-Bit Operations
- Serial Onboard Programming, No External Programming Voltage Needed
- Three-Channel Internal DMA
- Basic Timer With RTC Feature
- [Device Comparison](#) Summarizes Available Family Members



## 1.2 Applications

- Analog and Digital Sensor Systems
- Data Loggers
- General-Purpose Applications

## 1.3 Description

The TI MSP430™ family of ultra-low-power microcontrollers consists of several devices featuring different sets of peripherals targeted for various applications. The architecture, combined with extensive low-power modes, is optimized to achieve extended battery life in portable measurement applications. The device features a powerful 16-bit RISC CPU, 16-bit registers, and constant generators that contribute to maximum code efficiency. The digitally controlled oscillator (DCO) allows the device to wake up from low-power modes to active mode in 3.5 μs (typical).

The MSP430F522x series are microcontrollers with four 16-bit timers, a high-performance 10-bit ADC, two universal serial communication interfaces (USCIs), a hardware multiplier, DMA, a comparator, and an RTC module with alarm capabilities.

The MSP430F521x series include all of the peripherals of the MSP430F522x series with the exception of the ADC.

All devices have a split I/O supply system that allows for a seamless interface to other devices that have a nominal 1.8-V I/O interface without the need for external level translation.

For complete module descriptions, see the [MSP430F5xx and MSP430F6xx Family User's Guide](#). For design guidelines, see [Designing With MSP430F522x and MSP430F521x Devices](#).

**Device Information<sup>(1)</sup>**

PART NUMBER	PACKAGE	BODY SIZE <sup>(2)</sup>
MSP430F5229IRGC	VQFN (64)	9 mm × 9 mm
MSP430F5229IZQE	BGA (80)	5 mm × 5 mm
MSP430F5224IRGZ	VQFN (48)	7 mm × 7 mm
MSP430F5219IYFF	DSBGA (64)	See <a href="#">Section 8</a>

- (1) For the most current part, package, and ordering information, see the *Package Option Addendum* in [Section 8](#), or see the TI website at [www.ti.com](http://www.ti.com).
- (2) The dimensions shown here are approximations. For the package dimensions with tolerances, see the *Mechanical Data* in [Section 8](#).

### 1.4 Functional Block Diagrams

Figure 1-1 shows the functional block diagram for the MSP430F5229 and MSP430F5227 devices in the RGC, ZQE, YFF packages.

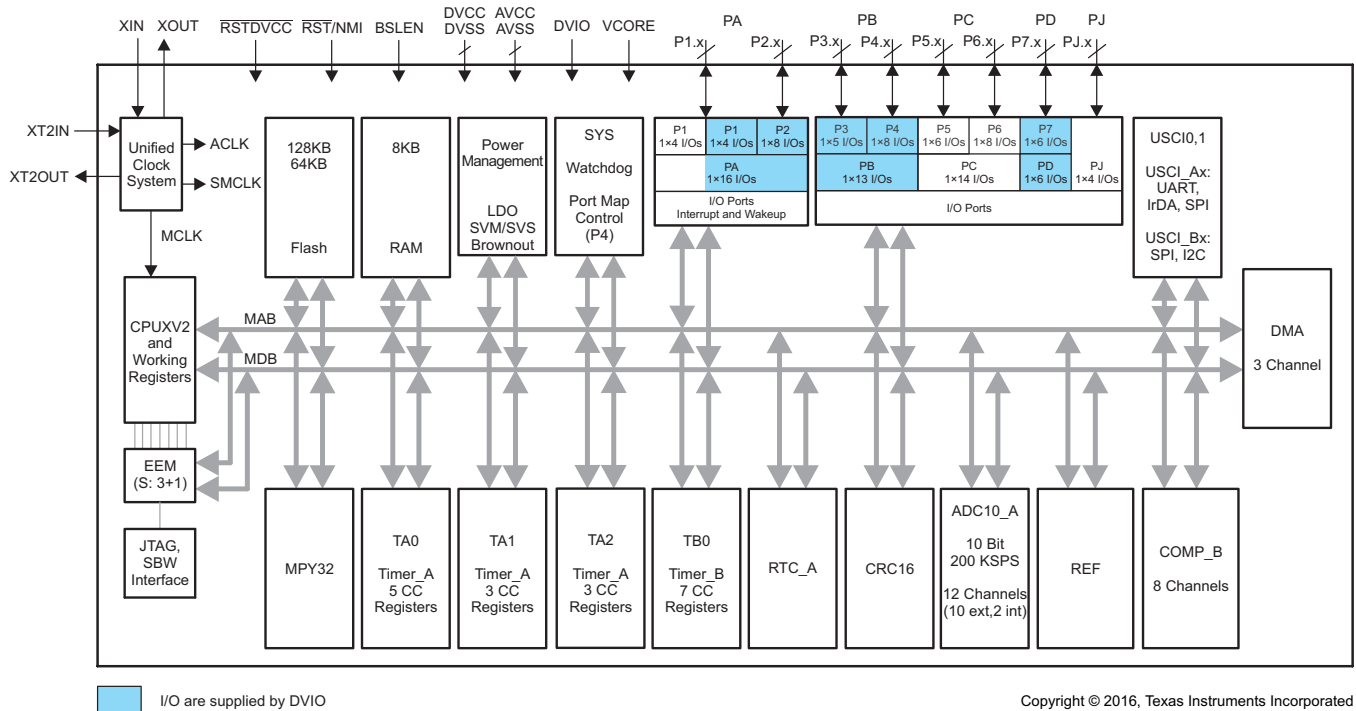

Figure 1-1. Functional Block Diagram – F5229, F5227 – RGC, ZQE, YFF Packages

Figure 1-2 shows the functional block diagram for the MSP430F5224 and MSP430F5222 devices in the RGZ package.

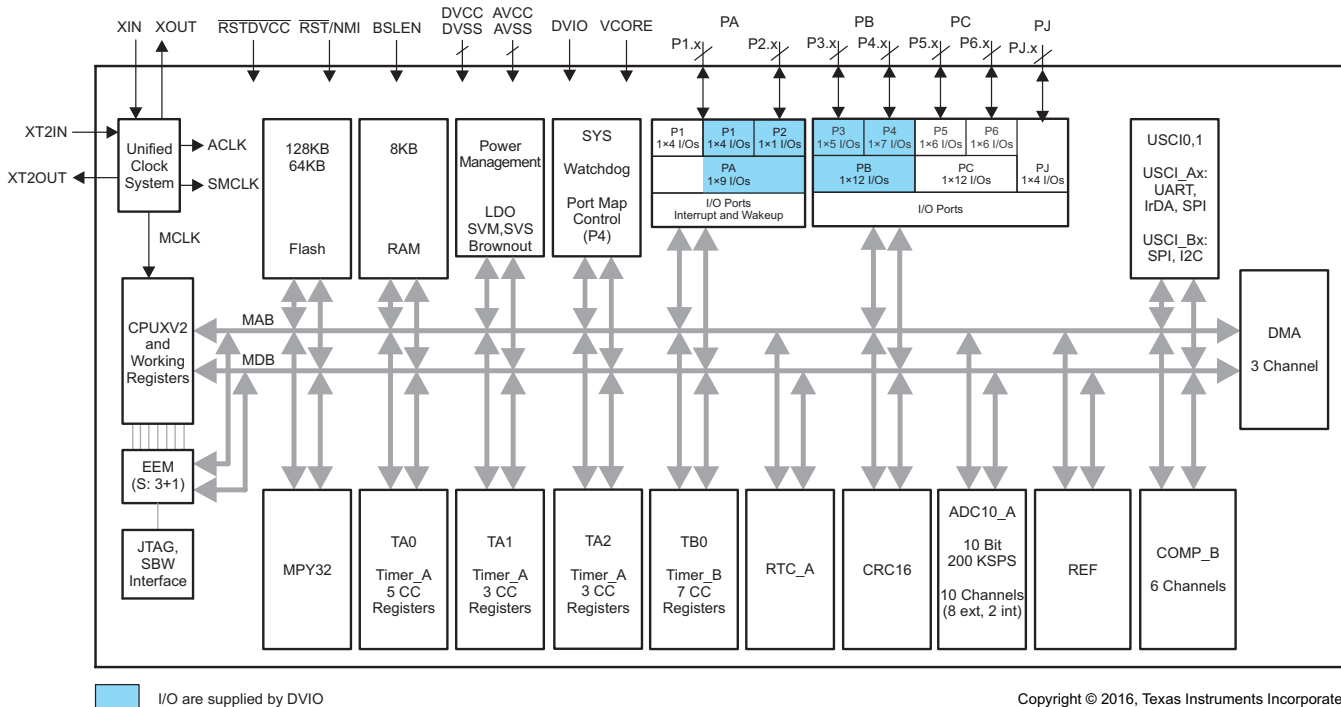

Figure 1-2. Functional Block Diagram – F5224, F5222 – RGZ Package

Figure 1-3 shows the functional block diagram for the MSP430F5219 and MSP430F5217 devices in the RGC, ZQE, and YFF packages.

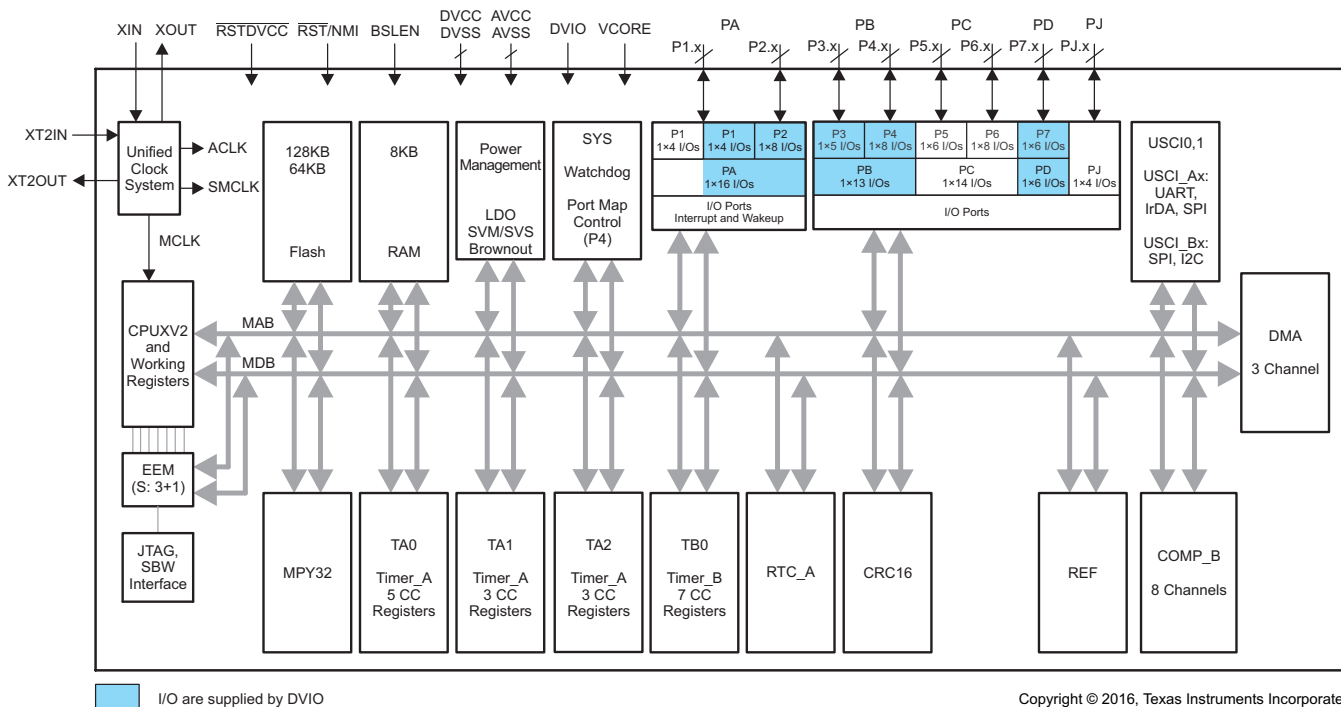

Figure 1-3. Functional Block Diagram – F5219, F5217 – RGC, ZQE, YFF Packages

Figure 1-4 shows the functional block diagram for the MSP430F5214 and MSP430F5212 devices in the RGZ package.

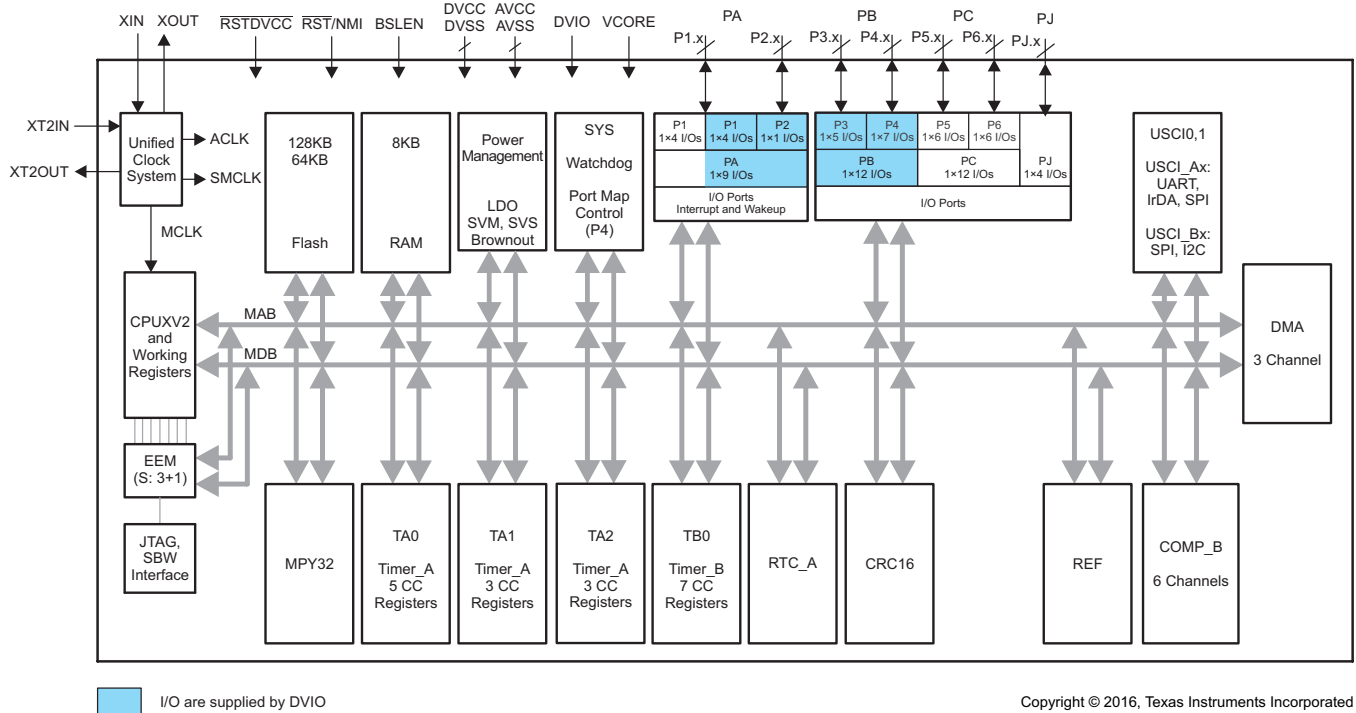

Figure 1-4. Functional Block Diagram – F5214, F5212 – RGZ Package

## Table of Contents

<b>1</b>	<b>Device Overview</b>	<b>1</b>	5.18	Output Frequency – General-Purpose I/O DVIO Domain (P1.4 to P1.7, P2.0 to P2.7, P3.0 to P3.4, P4.0 to P4.7, P7.0 to P7.5)	<b>30</b>
1.1	Features	1	5.19	Typical Characteristics – Outputs, Reduced Drive Strength (PxDS.y = 0)	<b>31</b>
1.2	Applications	2	5.20	Typical Characteristics – Outputs, Full Drive Strength (PxDS.y = 1)	<b>32</b>
1.3	Description	2	5.21	Crystal Oscillator, XT1, Low-Frequency Mode	<b>33</b>
1.4	Functional Block Diagrams	3	5.22	Crystal Oscillator, XT2	<b>34</b>
<b>2</b>	<b>Revision History</b>	<b>8</b>	5.23	Internal Very-Low-Power Low-Frequency Oscillator (VLO)	<b>35</b>
<b>3</b>	<b>Device Comparison</b>	<b>9</b>	5.24	Internal Reference, Low-Frequency Oscillator (REFO)	<b>35</b>
3.1	Related Products	9	5.25	DCO Frequency	<b>36</b>
<b>4</b>	<b>Terminal Configuration and Functions</b>	<b>10</b>	5.26	PMM, Brownout Reset (BOR)	<b>37</b>
4.1	Pin Diagrams	10	5.27	PMM, Core Voltage	<b>37</b>
4.2	Signal Descriptions	16	5.28	PMM, SVS High Side	<b>38</b>
<b>5</b>	<b>Specifications</b>	<b>21</b>	5.29	PMM, SVM High Side	<b>39</b>
5.1	Absolute Maximum Ratings	21	5.30	PMM, SVS Low Side	<b>39</b>
5.2	ESD Ratings	21	5.31	PMM, SVM Low Side	<b>40</b>
5.3	Recommended Operating Conditions	21	5.32	Wake-up Times From Low-Power Modes and Reset	<b>40</b>
5.4	Active Mode Supply Current Into V <sub>CC</sub> Excluding External Current	24	5.33	Timer_A	<b>41</b>
5.5	Low-Power Mode Supply Currents (Into V <sub>CC</sub> ) Excluding External Current	25	5.34	Timer_B	<b>41</b>
5.6	Thermal Resistance Characteristics	26	5.35	USCI (UART Mode), Recommended Operating Conditions	<b>42</b>
5.7	Schmitt-Trigger Inputs – General-Purpose I/O DVCC Domain (P1.0 to P1.3, P5.0 to P5.5, P6.0 to P6.7, PJ.0 to PJ.3, RSTDVCC)	27	5.36	USCI (UART Mode)	<b>42</b>
5.8	Schmitt-Trigger Inputs – General-Purpose I/O DVIO Domain (P1.4 to P1.7, P2.0 to P2.7, P3.0 to P3.4, P4.0 to P4.7, P7.0 to P7.5, RST/NMI, BSLN)	27	5.37	USCI (SPI Master Mode), Recommended Operating Conditions	<b>42</b>
5.9	Inputs – Interrupts DVCC Domain Port P1 (P1.0 to P1.3)	27	5.38	USCI (SPI Master Mode)	<b>42</b>
5.10	Inputs – Interrupts DVIO Domain Ports P1 and P2 (P1.4 to P1.7, P2.0 to P2.7)	27	5.39	USCI (SPI Slave Mode)	<b>44</b>
5.11	Leakage Current – General-Purpose I/O DVCC Domain (P1.0 to P1.3, P5.0 to P5.5, P6.0 to P6.7, PJ.0 to PJ.3)	28	5.40	USCI (I <sup>2</sup> C Mode)	<b>46</b>
5.12	Leakage Current – General-Purpose I/O DVIO Domain (P1.4 to P1.7, P2.0 to P2.7, P3.0 to P3.4, P4.0 to P4.7, P7.0 to P7.5)	28	5.41	10-Bit ADC, Power Supply and Input Range Conditions	<b>47</b>
5.13	Outputs – General-Purpose I/O DVCC Domain (Full Drive Strength) (P1.0 to P1.3, P5.0 to P5.5, P6.0 to P6.7, PJ.0 to PJ.3)	28	5.42	10-Bit ADC, Timing Parameters	<b>47</b>
5.14	Outputs – General-Purpose I/O DVCC Domain (Reduced Drive Strength) (P1.0 to P1.3, P5.0 to P5.5, P6.0 to P6.7, PJ.0 to PJ.3)	28	5.43	10-Bit ADC, Linearity Parameters	<b>48</b>
5.15	Outputs – General-Purpose I/O DVIO Domain (Full Drive Strength) (P1.4 to P1.7, P2.0 to P2.7, P3.0 to P3.4, P4.0 to P4.7, P7.0 to P7.5)	29	5.44	REF, External Reference	<b>48</b>
5.16	Outputs – General-Purpose I/O DVIO Domain (Reduced Drive Strength) (P1.4 to P1.7, P2.0 to P2.7, P3.0 to P3.4, P4.0 to P4.7, P7.0 to P7.5)	29	5.45	REF, Built-In Reference	<b>49</b>
5.17	Output Frequency – General-Purpose I/O DVCC Domain (P1.0 to P1.3, P5.0 to P5.5, P6.0 to P6.7, PJ.0 to PJ.3)	30	5.46	Comparator_B	<b>50</b>
			5.47	Flash Memory	<b>51</b>
			5.48	JTAG and Spy-Bi-Wire Interface	<b>51</b>
			5.49	DVIO BSL Entry	<b>52</b>
			<b>6</b>	<b>Detailed Description</b>	<b>53</b>
			6.1	CPU (Link to user's guide)	<b>53</b>
			6.2	Operating Modes	<b>54</b>
			6.3	Interrupt Vector Addresses	<b>55</b>
			6.4	Memory Organization	<b>56</b>
			6.5	Bootloader (BSL)	<b>58</b>
			6.6	JTAG Operation	<b>59</b>
			6.7	Flash Memory (Link to user's guide)	<b>60</b>
			6.8	RAM (Link to user's guide)	<b>60</b>
			6.9	Peripherals	<b>61</b>
			6.10	Input/Output Diagrams	<b>82</b>

---

6.11	Device Descriptors .....	<a href="#">99</a>	7.5	Related Links .....	<a href="#">110</a>
<b>7</b>	<b>Device and Documentation Support .....</b>	<b><a href="#">105</a></b>	7.6	Community Resources.....	<a href="#">110</a>
7.1	Getting Started.....	<a href="#">105</a>	7.7	Trademarks .....	<a href="#">110</a>
7.2	Device Nomenclature .....	<a href="#">105</a>	7.8	Electrostatic Discharge Caution .....	<a href="#">110</a>
7.3	Tools and Software .....	<a href="#">107</a>	7.9	Glossary.....	<a href="#">110</a>
7.4	Documentation Support.....	<a href="#">108</a>	<b>8</b>	<b>Mechanical, Packaging, and Orderable Information .....</b>	<b><a href="#">110</a></b>

---

## 2 Revision History

NOTE: Page numbers for previous revisions may differ from page numbers in the current version.

Changes from June 29, 2016 to September 26, 2018	Page
• Added <a href="#">Section 3.1, Related Products</a> .....	<a href="#">9</a>
• Removed D and E dimension lines on the YFF pinout (for the package dimensions with tolerances, see the <i>Mechanical Data</i> in <a href="#">Section 8</a> ) .....	<a href="#">15</a>
• Added typical conditions statements at the beginning of <a href="#">Section 5, Specifications</a> .....	<a href="#">21</a>
• Changed the MIN value of the V(DVCC_BOR_hys) parameter from 60 mV to 50 mV in <a href="#">Section 5.26, PMM, Brownout Reset (BOR)</a> .....	<a href="#">37</a>
• Updated notes (1) and (2) and added note (3) in <a href="#">Section 5.32, Wake-up Times From Low-Power Modes and Reset</a> .....	<a href="#">40</a>
• Removed ADC10DIV from the formula for the TYP value in the second row of the t <sub>CONVERT</sub> parameter in <a href="#">Section 5.42, 10-Bit ADC, Timing Parameters</a> (removed because ADC10CLK is after division) .....	<a href="#">47</a>
• Added second row for t <sub>EN_CMP</sub> with Test Conditions of "CBPWRMD = 10" and MAX value of 100 μs in <a href="#">Section 5.46, Comparator_B</a> .....	<a href="#">50</a>
• Renamed FCTL4.MGR0 and MGR1 in <a href="#">Section 5.47, Flash Memory</a> , to be consistent with header files .....	<a href="#">51</a>
• Throughout document, changed all instances of "bootstrap loader" to "bootloader" .....	<a href="#">58</a>
• Replaced former section <i>Development Tools Support</i> with <a href="#">Section 7.3, Tools and Software</a> .....	<a href="#">107</a>
• Added content to <a href="#">Section 7.4, Documentation Support</a> .....	<a href="#">108</a>

### 3 Device Comparison

Table 3-1 summarizes the available family members.

**Table 3-1. Family Members<sup>(1)(2)</sup>**

DEVICE	FLASH (KB)	SRAM (KB)	Timer_A <sup>(3)</sup>	Timer_B <sup>(4)</sup>	USCI		ADC10_A (Ch)	Comp_B (Ch)	I/O DVCC <sup>(5)</sup>	I/O DVIO <sup>(6)</sup>	PACKAGE
					CHANNEL A: UART, IrDA, SPI	CHANNEL B: SPI, I <sup>2</sup> C					
MSP430F5229	128	8	5, 3, 3	7	2	2	10 ext, 2 int	8	22	31	64 RGC 64 YFF 80 ZQE
MSP430F5227	64	8	5, 3, 3	7	2	2	10 ext, 2 int	8	22	31	64 RGC 64 YFF 80 ZQE
MSP430F5224	128	8	5, 3, 3	7	2	2	8 ext, 2 int	6	20	17	48 RGZ
MSP430F5222	64	8	5, 3, 3	7	2	2	8 ext, 2 int	6	20	17	48 RGZ
MSP430F5219	128	8	5, 3, 3	7	2	2	-	8	22	31	64 RGC 64 YFF 80 ZQE
MSP430F5217	64	8	5, 3, 3	7	2	2	-	8	22	31	64 RGC 64 YFF 80 ZQE
MSP430F5214	128	8	5, 3, 3	7	2	2	-	6	20	17	48 RGZ
MSP430F5212	64	8	5, 3, 3	7	2	2	-	6	20	17	48 RGZ

- (1) For the most current device, package, and ordering information, see the *Package Option Addendum* in [Section 8](#), or see the TI website at [www.ti.com](http://www.ti.com).
- (2) Package drawings, standard packing quantities, thermal data, symbolization, and PCB design guidelines are available at [www.ti.com/packaging](http://www.ti.com/packaging).
- (3) Each number in the sequence represents an instantiation of Timer\_A with its associated number of capture compare registers and PWM output generators available. For example, a number sequence of 3, 5 would represent two instantiations of Timer\_A, the first instantiation having 3 and the second instantiation having 5 capture compare registers and PWM output generators, respectively.
- (4) Each number in the sequence represents an instantiation of Timer\_B with its associated number of capture compare registers and PWM output generators available. For example, a number sequence of 3, 5 would represent two instantiations of Timer\_B, the first instantiation having 3 and the second instantiation having 5 capture compare registers and PWM output generators, respectively.
- (5) All of these I/Os reside on a single voltage rail supplied by DVCC.
- (6) All of these I/Os reside on a single voltage rail supplied by DVIO.

#### 3.1 Related Products

For information about other devices in this family of products or related products, see the following links.

**Products for TI Microcontrollers** TI's low-power and high-performance MCUs, with wired and wireless connectivity options, are optimized for a broad range of applications.

**Products for MSP430 Ultra-Low-Power Microcontrollers** One platform. One ecosystem. Endless possibilities. Enabling the connected world with innovations in ultra-low-power microcontrollers with advanced peripherals for precise sensing and measurement.

**Companion Products for MSP430F5229** Review products that are frequently purchased or used with this product.

**Reference Designs for MSP430F5229** Find reference designs that leverage the best in TI technology to solve your system-level challenges.

## 4 Terminal Configuration and Functions

### 4.1 Pin Diagrams

Figure 4-1 shows the pinout for the MSP430F5229 and MSP430F5227 devices in the 64-pin RGC package.

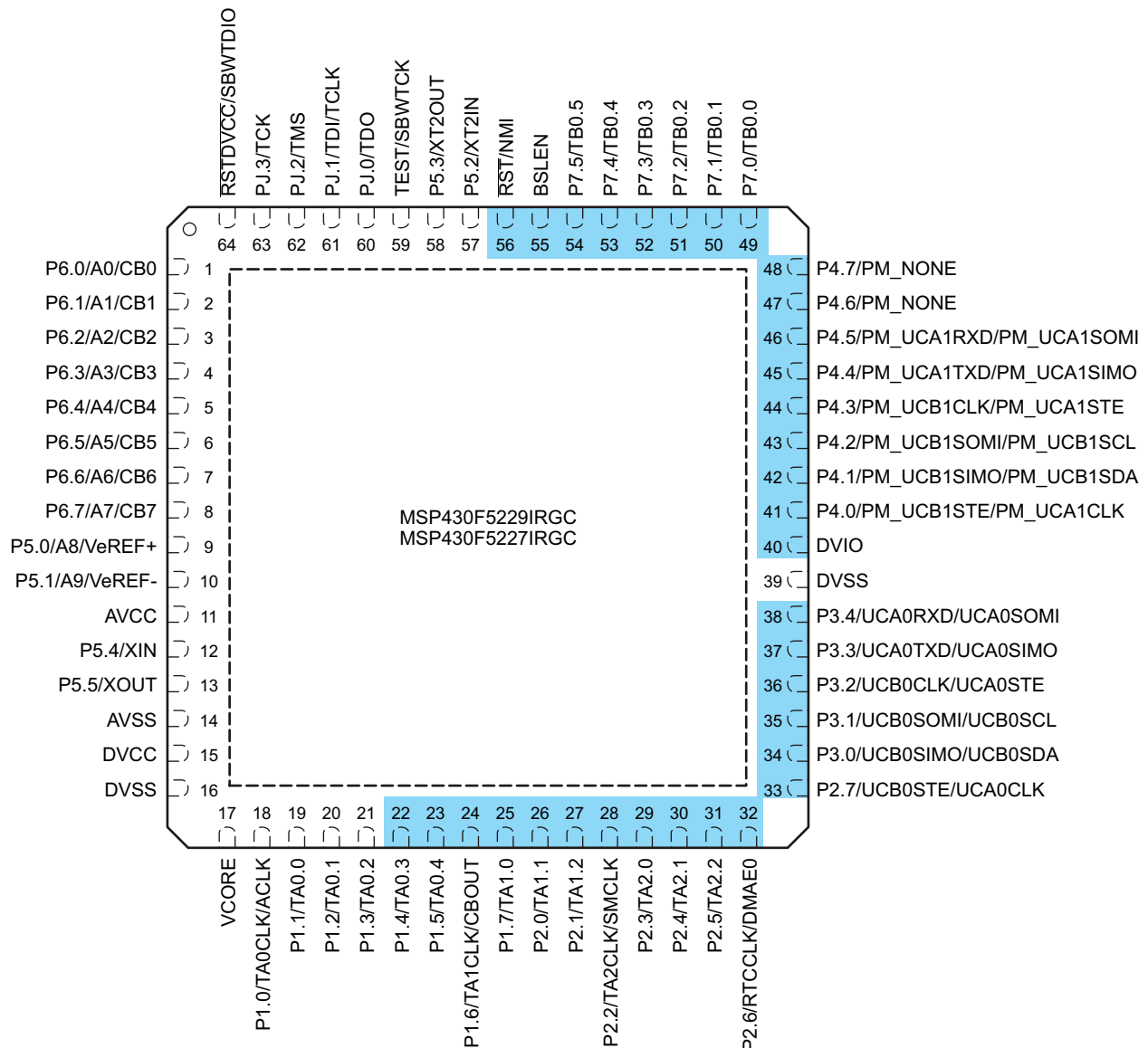

Supplied by DVIO

NOTE: TI recommends connection of exposed thermal pad to V<sub>SS</sub>.

Figure 4-1. 64-Pin RGC Package – F5229, F5227

Figure 4-2 shows the pinout for the MSP430F5224 and MSP430F5222 devices in the 48-pin RGZ package.

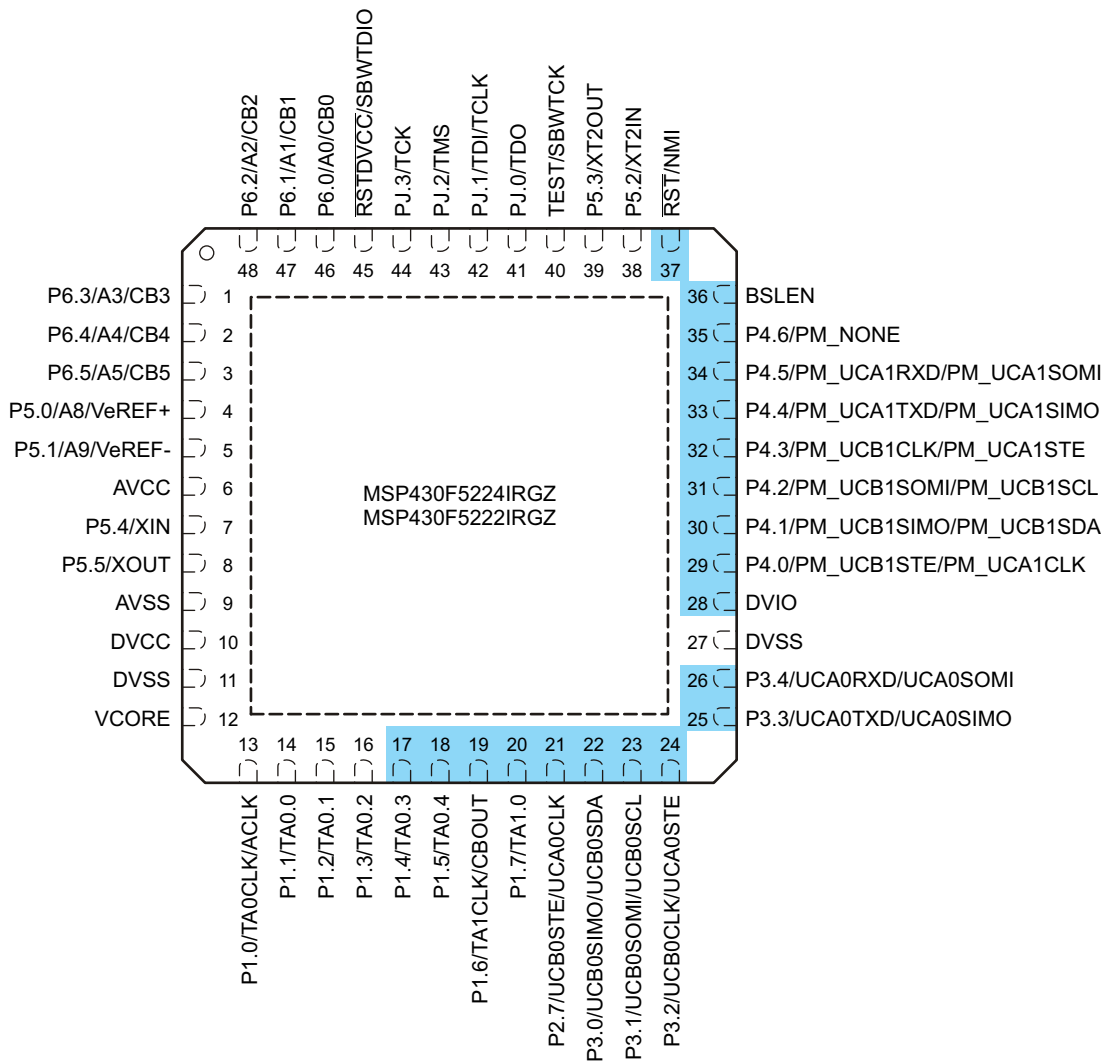

Supplied by DVIO

NOTE: TI recommends connection of exposed thermal pad to V<sub>SS</sub>.

Figure 4-2. 48-Pin RGZ Package – F5224, F5222

Figure 4-3 shows the pinout for the MSP430F5219 and MSP430F5217 devices in the 64-pin RGC package.

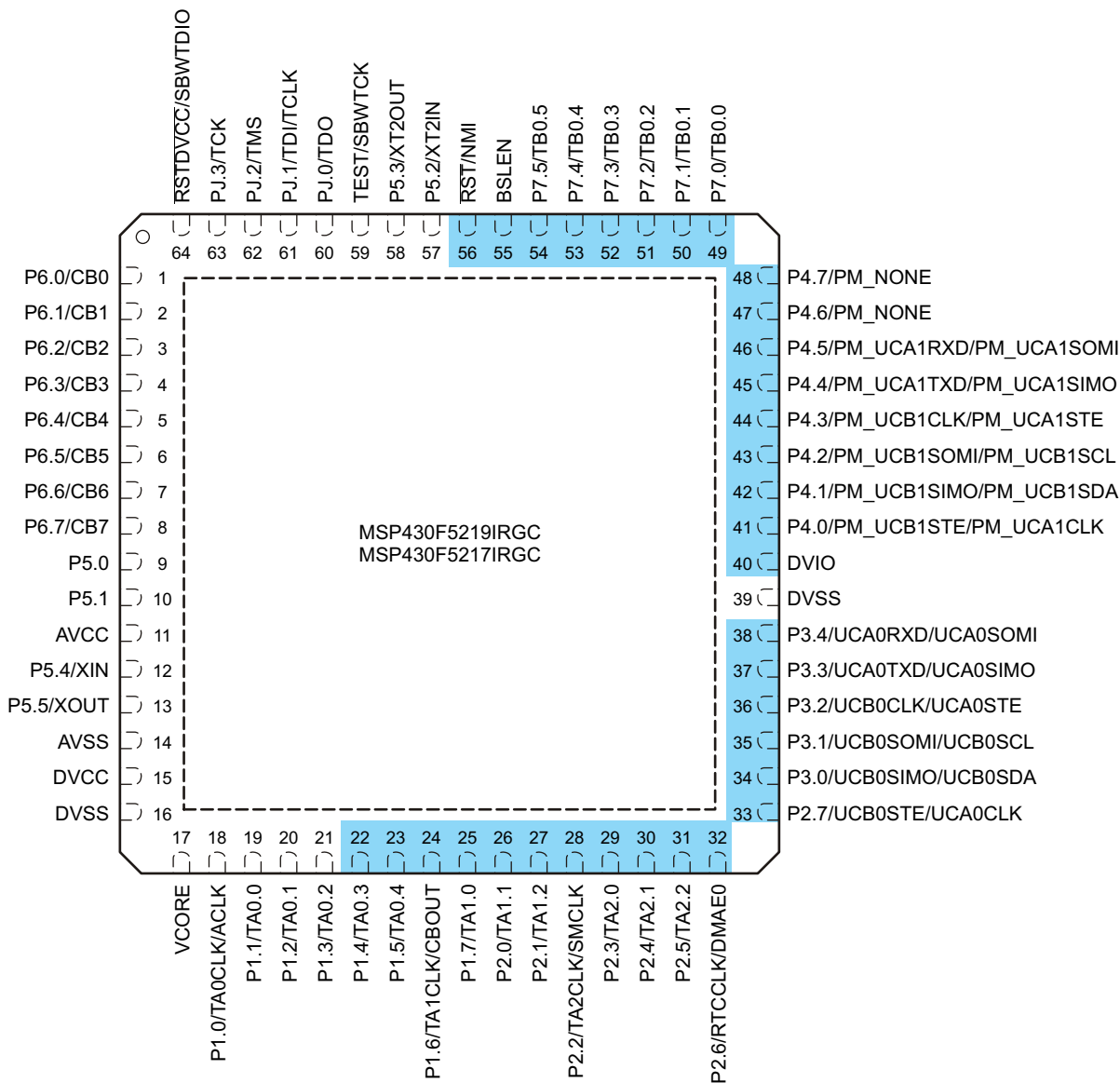

 Supplied by DVIO

NOTE: TI recommends connection of exposed thermal pad to V<sub>SS</sub>.

**Figure 4-3. 64-Pin RGC Package – F5219, F5217**

Figure 4-4 shows the pinout for the MSP430F5214 and MSP430F5212 devices in the 48-pin RGZ package.

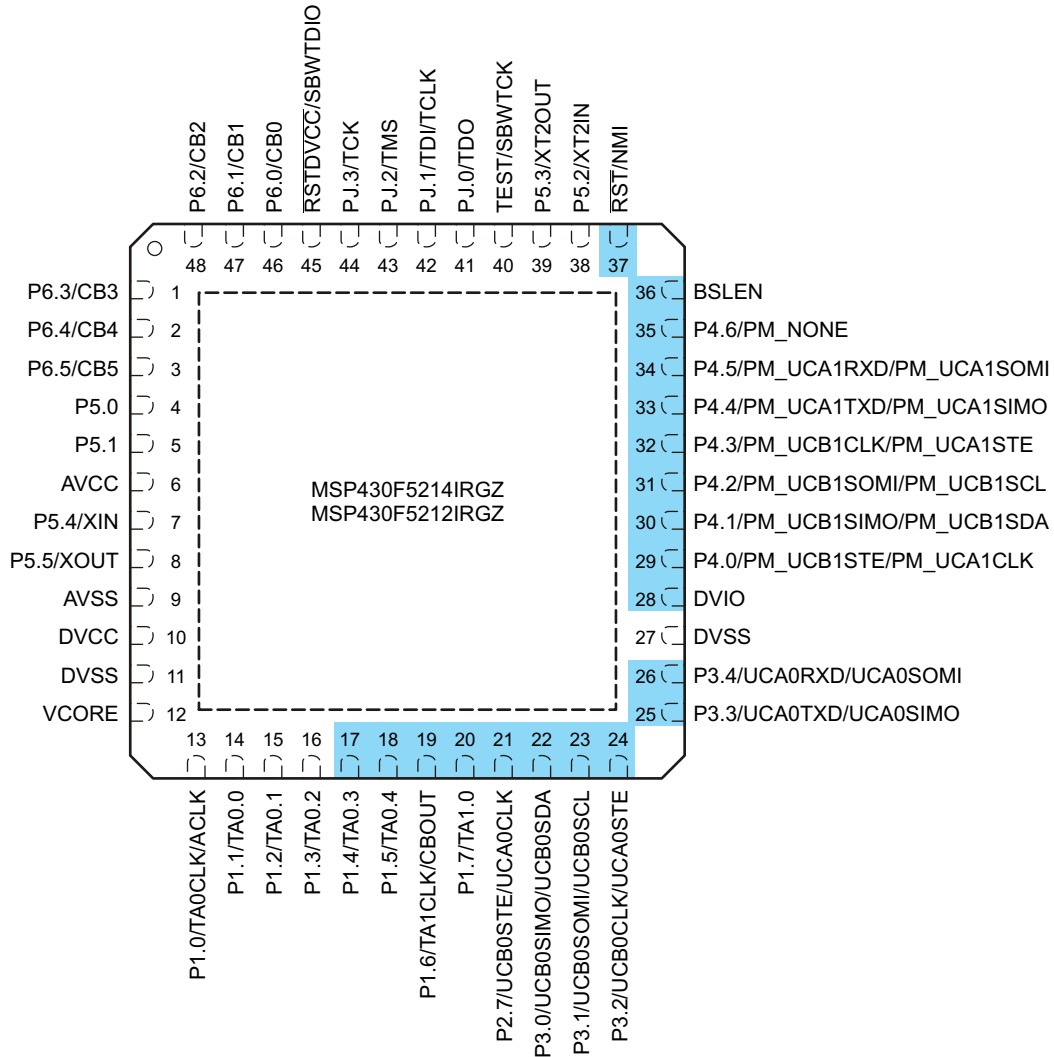

Supplied by DVIO

NOTE: TI recommends connection of exposed thermal pad to V<sub>SS</sub>.

**Figure 4-4. 48-Pin RGZ Package – F5214, F5212**

Figure 4-5 shows the pinout for the MSP430F5229, MSP430F5227, MSP430F5219, and MSP430F5217 devices in the 80-pin ZQE package.

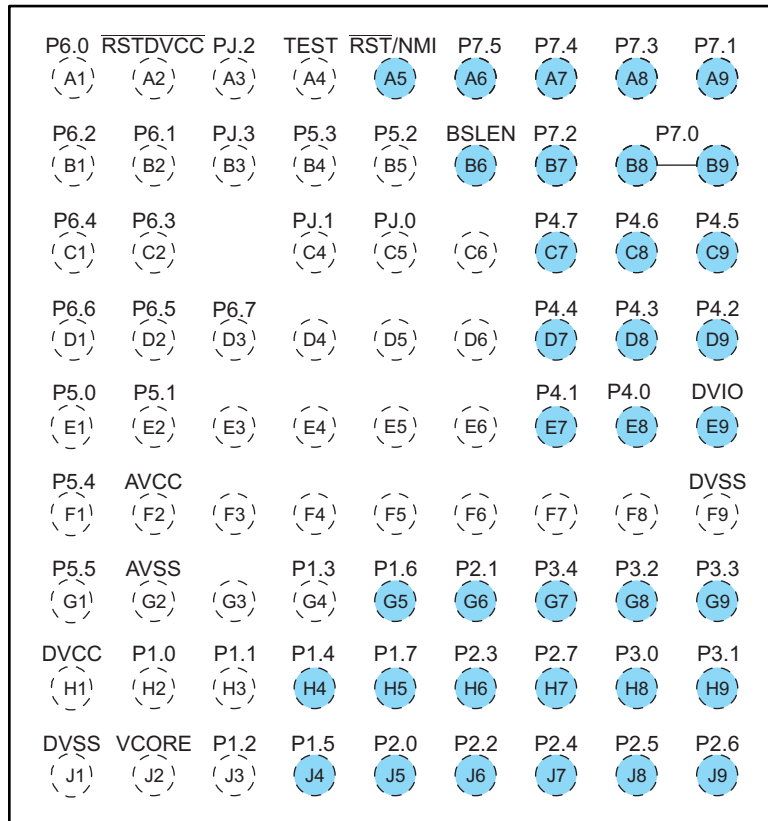

 Supplied by DVIO

Figure 4-5. 80-Pin ZQE Package – F5229, F5227, F5219, F5217

Figure 4-6 shows the pinout for the MSP430F5229, MSP430F5227, MSP430F5219, and MSP430F5217 devices in the 64-pin YFF package.

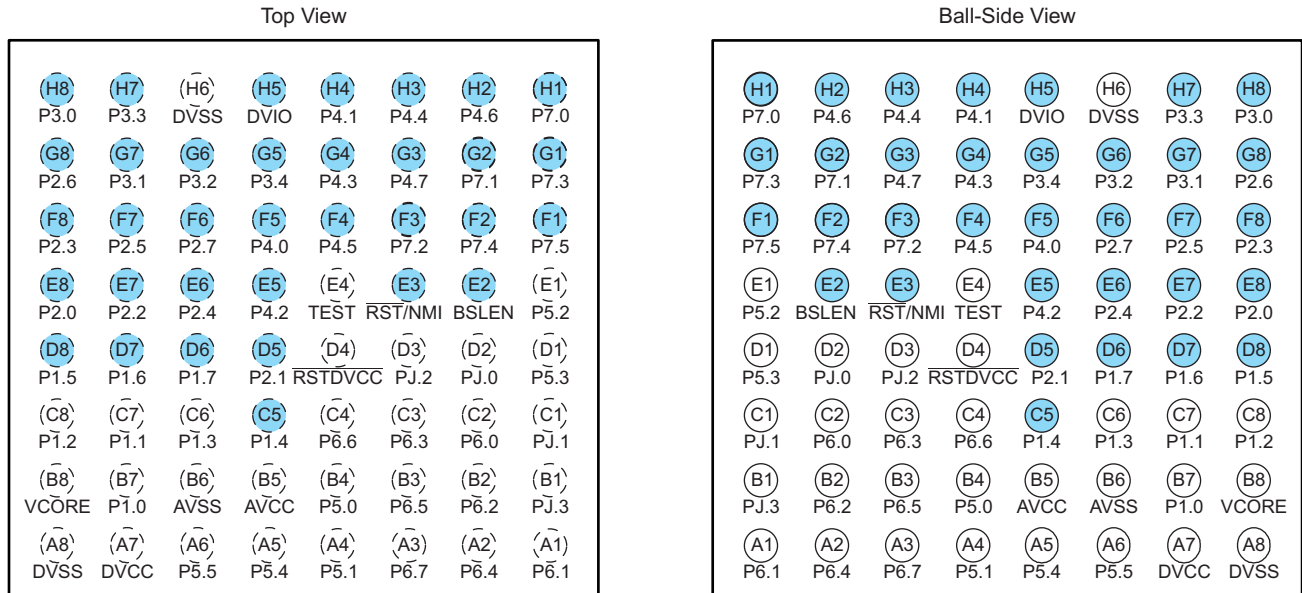

**Figure 4-6. 64-Pin YFF Package – F5229, F5227, F5219, F5217**

## 4.2 Signal Descriptions

Table 4-1 describes the signals for all device variants and package options.

**Table 4-1. Terminal Functions**

NAME	TERMINAL NO.				I/O <sup>(1)</sup>	SUPPLY	DESCRIPTION
	RGC	ZQE	YFF	RGZ			
P6.0/CB0/A0	1	A1	C2	46	I/O	DVCC	General-purpose digital I/O Comparator_B input CB0 Analog input A0 for ADC (not available on all device types)
P6.1/CB1/A1	2	B2	A1	47	I/O	DVCC	General-purpose digital I/O Comparator_B input CB1 Analog input A1 for ADC (not available on all device types)
P6.2/CB2/A2	3	B1	B2	48	I/O	DVCC	General-purpose digital I/O Comparator_B input CB2 Analog input A2 for ADC (not available on all device types)
P6.3/CB3/A3	4	C2	C3	1	I/O	DVCC	General-purpose digital I/O Comparator_B input CB3 Analog input A3 for ADC (not available on all device types)
P6.4/CB4/A4	5	C1	A2	2	I/O	DVCC	General-purpose digital I/O Comparator_B input CB4 Analog input A4 for ADC (not available on all device types)
P6.5/CB5/A5	6	D2	B3	3	I/O	DVCC	General-purpose digital I/O Comparator_B input CB5 Analog input A5 for ADC (not available on all device types)
P6.6/CB6/A6	7	D1	C4	N/A	I/O	DVCC	General-purpose digital I/O (not available on all device types) Comparator_B input CB6 (not available on all device types) Analog input A6 for ADC (not available on all device types)
P6.7/CB7/A7	8	D3	A3	N/A	I/O	DVCC	General-purpose digital I/O (not available on all device types) Comparator_B input CB7 (not available on all device types) Analog input A7 for ADC (not available on all device types)
P5.0/A8/VeREF+	9	E1	B4	4	I/O	DVCC	General-purpose digital I/O Analog input A8 for ADC (not available on all device types) Input for an external reference voltage to the ADC (not available on all device types)
P5.1/A9/VeREF-	10	E2	A4	5	I/O	DVCC	General-purpose digital I/O Analog input A9 for ADC (not available on all device types) Negative terminal for the ADC reference voltage for an external applied reference voltage (not available on all device types)
AVCC	11	F2	B5	6			Analog power supply
P5.4/XIN	12	F1	A5	7	I/O	DVCC	General-purpose digital I/O Input terminal for crystal oscillator XT1 <sup>(2)</sup>
P5.5/XOUT	13	G1	A6	8	I/O	DVCC	General-purpose digital I/O Output terminal of crystal oscillator XT1
AVSS	14	G2	B6	9			Analog ground supply

(1) I = input, O = output, N/A = not available

(2) When in crystal bypass mode, XIN can be configured so that it can support an input digital waveform with swing levels from DVSS to DVCC or DVSS to DVIO. In this case, it is required that the pin be configured properly for the intended input swing.

**Table 4-1. Terminal Functions (continued)**

TERMINAL					I/O <sup>(1)</sup>	SUPPLY	DESCRIPTION
NAME	NO.						
	RGC	ZQE	YFF	RGZ			
DVCC	15	H1	A7	10			Digital power supply
DVSS	16	J1	A8	11			Digital ground supply
VCORE <sup>(3)</sup>	17	J2	B8	12		DVCC	Regulated core power supply output (internal use only, no external current loading)
P1.0/TA0CLK/ACLK	18	H2	B7	13	I/O	DVCC	General-purpose digital I/O with port interrupt TA0 clock signal TA0CLK input ACLK output (divided by 1, 2, 4, 8, 16, or 32)
P1.1/TA0.0	19	H3	C7	14	I/O	DVCC	General-purpose digital I/O with port interrupt TA0 CCR0 capture: CCI0A input, compare: Out0 output BSL transmit output
P1.2/TA0.1	20	J3	C8	15	I/O	DVCC	General-purpose digital I/O with port interrupt TA0 CCR1 capture: CCI1A input, compare: Out1 output BSL receive input
P1.3/TA0.2	21	G4	C6	16	I/O	DVCC	General-purpose digital I/O with port interrupt TA0 CCR2 capture: CCI2A input, compare: Out2 output
P1.4/TA0.3	22	H4	C5	17	I/O	DVIO <sup>(4)</sup>	General-purpose digital I/O with port interrupt TA0 CCR3 capture: CCI3A input compare: Out3 output
P1.5/TA0.4	23	J4	D8	18	I/O	DVIO <sup>(4)</sup>	General-purpose digital I/O with port interrupt TA0 CCR4 capture: CCI4A input, compare: Out4 output
P1.6/TA1CLK/CBOUT	24	G5	D7	19	I/O	DVIO <sup>(4)</sup>	General-purpose digital I/O with port interrupt TA1 clock signal TA1CLK input Comparator_B output
P1.7/TA1.0	25	H5	D6	20	I/O	DVIO <sup>(4)</sup>	General-purpose digital I/O with port interrupt TA1 CCR0 capture: CCI0A input, compare: Out0 output
P2.0/TA1.1	26	J5	E8	N/A	I/O	DVIO <sup>(4)</sup>	General-purpose digital I/O with port interrupt (not available on all device types) TA1 CCR1 capture: CCI1A input, compare: Out1 output (not available on all device types)
P2.1/TA1.2	27	G6	D5	N/A	I/O	DVIO <sup>(4)</sup>	General-purpose digital I/O with port interrupt (not available on all device types) TA1 CCR2 capture: CCI2A input, compare: Out2 output (not available on all device types)
P2.2/TA2CLK/SMCLK	28	J6	E7	N/A	I/O	DVIO <sup>(4)</sup>	General-purpose digital I/O with port interrupt (not available on all device types) TA2 clock signal TA2CLK input SMCLK output (not available on all device types)
P2.3/TA2.0	29	H6	F8	N/A	I/O	DVIO <sup>(4)</sup>	General-purpose digital I/O with port interrupt (not available on all device types) TA2 CCR0 capture: CCI0A input, compare: Out0 output (not available on all device types)
P2.4/TA2.1	30	J7	E6	N/A	I/O	DVIO <sup>(4)</sup>	General-purpose digital I/O with port interrupt (not available on all device types) TA2 CCR1 capture: CCI1A input, compare: Out1 output (not available on all device types)

(3) V<sub>CORE</sub> is for internal use only. No external current loading is possible. V<sub>CORE</sub> should only be connected to the recommended capacitor value, C<sub>V<sub>CORE</sub></sub>.

(4) This pin function is supplied by DVIO. See [Section 5.8](#) for input and output requirements.

**Table 4-1. Terminal Functions (continued)**

TERMINAL					I/O <sup>(1)</sup>	SUPPLY	DESCRIPTION
NAME	NO.						
	RGC	ZQE	YFF	RGZ			
P2.5/TA2.2	31	J8	F7	N/A	I/O	DVIO <sup>(4)</sup>	General-purpose digital I/O with port interrupt (not available on all device types) TA2 CCR2 capture: CCI2A input, compare: Out2 output (not available on all device types)
P2.6/RTCCLK/DMAE0	32	J9	G8	N/A	I/O	DVIO <sup>(4)</sup>	General-purpose digital I/O with port interrupt (not available on all device types) RTC clock output for calibration (not available on all device types) DMA external trigger input (not available on all device types)
P2.7/UCB0STE/ UCA0CLK	33	H7	F6	21	I/O	DVIO <sup>(4)</sup>	General-purpose digital I/O Slave transmit enable – USCI_B0 SPI mode Clock signal input – USCI_A0 SPI slave mode Clock signal output – USCI_A0 SPI master mode
P3.0/UCB0SIMO/ UCB0SDA	34	H8	H8	22	I/O	DVIO <sup>(4)</sup>	General-purpose digital I/O Slave in, master out – USCI_B0 SPI mode I <sup>2</sup> C data – USCI_B0 I <sup>2</sup> C mode
P3.1/UCB0SOMI/ UCB0SCL	35	H9	G7	23	I/O	DVIO <sup>(4)</sup>	General-purpose digital I/O Slave out, master in – USCI_B0 SPI mode I <sup>2</sup> C clock – USCI_B0 I <sup>2</sup> C mode
P3.2/UCB0CLK/ UCA0STE	36	G8	G6	24	I/O	DVIO <sup>(4)</sup>	General-purpose digital I/O Clock signal input – USCI_B0 SPI slave mode Clock signal output – USCI_B0 SPI master mode Slave transmit enable – USCI_A0 SPI mode
P3.3/UCA0TXD/ UCA0SIMO	37	G9	H7	25	I/O	DVIO <sup>(4)</sup>	General-purpose digital I/O Transmit data – USCI_A0 UART mode Slave in, master out – USCI_A0 SPI mode
P3.4/UCA0RXD/ UCA0SOMI	38	G7	G5	26	I/O	DVIO <sup>(4)</sup>	General-purpose digital I/O Receive data – USCI_A0 UART mode Slave out, master in – USCI_A0 SPI mode
DVSS	39	F9	H6	27			Digital ground supply
DVIO <sup>(5)</sup>	40	E9	H5	28			Digital I/O power supply
P4.0/PM_UCB1STE/ PM_UCA1CLK	41	E8	F5	29	I/O	DVIO <sup>(4)</sup>	General-purpose digital I/O with reconfigurable port mapping secondary function Default mapping: Slave transmit enable – USCI_B1 SPI mode Default mapping: Clock signal input – USCI_A1 SPI slave mode Default mapping: Clock signal output – USCI_A1 SPI master mode
P4.1/PM_UCB1SIMO/ PM_UCB1SDA	42	E7	H4	30	I/O	DVIO <sup>(4)</sup>	General-purpose digital I/O with reconfigurable port mapping secondary function Default mapping: Slave in, master out – USCI_B1 SPI mode Default mapping: I <sup>2</sup> C data – USCI_B1 I <sup>2</sup> C mode
P4.2/PM_UCB1SOMI/ PM_UCB1SCL	43	D9	E5	31	I/O	DVIO <sup>(4)</sup>	General-purpose digital I/O with reconfigurable port mapping secondary function Default mapping: Slave out, master in – USCI_B1 SPI mode Default mapping: I <sup>2</sup> C clock – USCI_B1 I <sup>2</sup> C mode

(5) The voltage on DVIO is not supervised or monitored.

**Table 4-1. Terminal Functions (continued)**

TERMINAL					I/O <sup>(1)</sup>	SUPPLY	DESCRIPTION
NAME	NO.						
	RGC	ZQE	YFF	RGZ			
P4.3/PM_UCB1CLK/ PM_UCA1STE	44	D8	G4	32	I/O	DVIO <sup>(4)</sup>	General-purpose digital I/O with reconfigurable port mapping secondary function Default mapping: Clock signal input – USCI_B1 SPI slave mode Default mapping: Clock signal output – USCI_B1 SPI master mode Default mapping: Slave transmit enable – USCI_A1 SPI mode
P4.4/PM_UCA1TXD/ PM_UCA1SIMO	45	D7	H3	33	I/O	DVIO <sup>(4)</sup>	General-purpose digital I/O with reconfigurable port mapping secondary function Default mapping: Transmit data – USCI_A1 UART mode Default mapping: Slave in, master out – USCI_A1 SPI mode
P4.5/PM_UCA1RXD/ PM_UCA1SOMI	46	C9	F4	34	I/O	DVIO <sup>(4)</sup>	General-purpose digital I/O with reconfigurable port mapping secondary function Default mapping: Receive data – USCI_A1 UART mode Default mapping: Slave out, master in – USCI_A1 SPI mode
P4.6/PM_NONE	47	C8	H2	35	I/O	DVIO <sup>(4)</sup>	General-purpose digital I/O with reconfigurable port mapping secondary function Default mapping: no secondary function
P4.7/PM_NONE	48	C7	G3	N/A	I/O	DVIO <sup>(4)</sup>	General-purpose digital I/O with reconfigurable port mapping secondary function (not available on all device types) Default mapping: no secondary function (not available on all device types)
P7.0/TB0.0	49	B8, B9	H1	N/A	I/O	DVIO <sup>(4)</sup>	General-purpose digital I/O (not available on all device types) TB0 CCR0 capture: CCI0A input, compare: Out0 output (not available on all device types)
P7.1/TB0.1	50	A9	G2	N/A	I/O	DVIO <sup>(4)</sup>	General-purpose digital I/O (not available on all device types) TB0 CCR1 capture: CCI1A input, compare: Out1 output (not available on all device types)
P7.2/TB0.2	51	B7	F3	N/A	I/O	DVIO <sup>(4)</sup>	General-purpose digital I/O (not available on all device types) TB0 CCR2 capture: CCI2A input, compare: Out2 output (not available on all device types)
P7.3/TB0.3	52	A8	G1	N/A	I/O	DVIO <sup>(4)</sup>	General-purpose digital I/O (not available on all device types) TB0 CCR3 capture: CCI3A input, compare: Out3 output (not available on all device types)
P7.4/TB0.4	53	A7	F2	N/A	I/O	DVIO <sup>(4)</sup>	General-purpose digital I/O (not available on all device types) TB0 CCR4 capture: CCI4A input, compare: Out4 output (not available on all device types)
P7.5/TB0.5	54	A6	F1	N/A	I/O	DVIO <sup>(4)</sup>	General-purpose digital I/O (not available on all device types) TB0 CCR5 capture: CCI5A input, compare: Out5 output (not available on all device types)
BSLEN	55	B6	E2	36	I	DVIO <sup>(4)</sup>	BSL enable with internal pulldown
$\overline{\text{RST}}$ /NMI	56	A5	E3	37	I	DVIO <sup>(4)</sup>	Reset input active low <sup>(6)(7)</sup> Nonmaskable interrupt input <sup>(6)</sup>
P5.2/XT2IN	57	B5	E1	38	I/O	DVCC	General-purpose digital I/O Input terminal for crystal oscillator XT2 <sup>(8)</sup>

(6) This pin is configurable as reset or NMI and resides on the DVIO supply domain. When driven from external, input swing levels from DVSS to DVIO are required.

(7) When this pin is configured as reset, the internal pullup resistor is enabled by default.

(8) When in crystal bypass mode, XT2IN can be configured so that it can support an input digital waveform with swing levels from DVSS to DVCC or DVSS to DVIO. In this case, it is required that the pin be configured properly for the intended input swing.

**Table 4-1. Terminal Functions (continued)**

TERMINAL					I/O <sup>(1)</sup>	SUPPLY	DESCRIPTION
NAME	NO.						
	RGC	ZQE	YFF	RGZ			
P5.3/XT2OUT	58	B4	D1	39	I/O	DVCC	General-purpose digital I/O Output terminal of crystal oscillator XT2
TEST/SBWTCK <sup>(9)</sup>	59	A4	E4	40	I	DVCC	Test mode pin – Selects four wire JTAG operation Spy-Bi-Wire input clock when Spy-Bi-Wire operation activated
PJ.0/TDO <sup>(10)</sup>	60	C5	D2	41	I/O	DVCC	General-purpose digital I/O JTAG test data output port
PJ.1/TDI/TCLK <sup>(10)</sup>	61	C4	C1	42	I/O	DVCC	General-purpose digital I/O JTAG test data input or test clock input
PJ.2/TMS <sup>(10)</sup>	62	A3	D3	43	I/O	DVCC	General-purpose digital I/O JTAG test mode select
PJ.3/TCK <sup>(10)</sup>	63	B3	B1	44	I/O	DVCC	General-purpose digital I/O JTAG test clock
<u>R</u> STDVCC/ SBWTDIO <sup>(10)</sup>	64	A2	D4	45	I/O	DVCC	Reset input, active-low <sup>(11)</sup> Spy-Bi-Wire data input/output when Spy-Bi-Wire operation activated
Reserved	N/A	<sup>(12)</sup> N/A	N/A	N/A			Reserved
QFN Pad	Pad	N/A	N/A	Pad			QFN thermal pad. TI recommends connecting to V <sub>SS</sub> .

(9) See [Section 6.5](#) and [Section 6.6](#) for use with BSL and JTAG functions.

(10) See [Section 6.6](#) for use with JTAG function.

(11) This nonconfigurable reset resides on the DVCC supply domain and has an internal pullup to DVCC. When driven from external, input swing levels from DVSS to DVCC are required. This reset must be used for Spy-Bi-Wire communication and is not the same RST/NMI reset as found on other devices in the MSP430 family. See [Section 6.5](#) and [Section 6.6](#) for details regarding the use of this pin.

(12) C6, D4, D5, D6, E3, E4, E5, E6, F3, F4, F5, F6, F7, F8, G3 are reserved and should be connected to ground.

## 5 Specifications

All graphs in this section are for typical conditions, unless otherwise noted.

Typical (TYP) values are specified at  $V_{CC} = 3.3\text{ V}$  and  $T_A = 25^\circ\text{C}$ , unless otherwise noted.

### 5.1 Absolute Maximum Ratings

over operating free-air temperature range (unless otherwise noted)<sup>(1)</sup>

	MIN	MAX	UNIT
Voltage applied at $V_{CC}$ to $V_{SS}$	-0.3	4.1	V
Voltage applied at $V_{IO}$ to $V_{SS}$	-0.3	2.2	V
Voltage applied to any pin (excluding V <sub>CORE</sub> and $V_{IO}$ pins) <sup>(2)</sup>	-0.3	$V_{CC} + 0.3$	V
Voltage applied to $V_{IO}$ pins	-0.3	$V_{IO} + 0.2$	V
Diode current at any device pin		±2	mA
Storage temperature, $T_{stg}$ <sup>(3)</sup>	-55	150	°C

- (1) Stresses beyond those listed under *Absolute Maximum Ratings* may cause permanent damage to the device. These are stress ratings only, and functional operation of the device at these or any other conditions beyond those indicated under *Recommended Operating Conditions* is not implied. Exposure to absolute-maximum-rated conditions for extended periods may affect device reliability.
- (2) All voltages referenced to  $V_{SS}$ . V<sub>CORE</sub> is for internal device use only. No external DC loading or voltage should be applied.
- (3) Higher temperature may be applied during board soldering according to the current JEDEC J-STD-020 specification with peak reflow temperatures not higher than classified on the device label on the shipping boxes or reels.

### 5.2 ESD Ratings

	VALUE	UNIT
$V_{(ESD)}$ Electrostatic discharge	Human-body model (HBM), per ANSI/ESDA/JEDEC JS-001 <sup>(1)</sup>	±1000
	Charged-device model (CDM), per JEDEC specification JESD22-C101 <sup>(2)</sup>	±250

- (1) JEDEC document JEP155 states that 500-V HBM allows safe manufacturing with a standard ESD control process. Pins listed as ±1000 V may actually have higher performance.
- (2) JEDEC document JEP157 states that 250-V CDM allows safe manufacturing with a standard ESD control process. Pins listed as ±250 V may actually have higher performance.

### 5.3 Recommended Operating Conditions

	MIN	NOM	MAX	UNIT
$V_{CC}$ Supply voltage during program execution and flash programming ( $AVCC = DVCC$ ) <sup>(1)(2)(3)</sup>	PMMCOREV <sub>x</sub> = 0	1.8	3.6	V
	PMMCOREV <sub>x</sub> = 0, 1	2.0	3.6	
	PMMCOREV <sub>x</sub> = 0, 1, 2	2.2	3.6	
	PMMCOREV <sub>x</sub> = 0, 1, 2, 3	2.4	3.6	
$V_{IO}$ Supply voltage applied to DVIO referenced to $V_{SS}$ <sup>(2)</sup>	1.62		1.98	V
$V_{SS}$ Supply voltage ( $AVSS = DVSS$ )		0		V
$T_A$ Operating free-air temperature	-40		85	°C
$T_J$ Operating junction temperature	-40		85	°C
$C_{VCORE}$ Recommended capacitor at V <sub>CORE</sub> <sup>(4)</sup>		470		nF
$C_{DVCC}/C_{VCORE}$ Capacitor ratio of DVCC to V <sub>CORE</sub>	10			

- (1) TI recommends powering AVCC and DVCC from the same source. A maximum difference of 0.3 V between AVCC and DVCC can be tolerated during power up and operation.
- (2) During  $V_{CC}$  and  $V_{IO}$  power up, it is required that  $V_{IO} \geq V_{CC}$  during the ramp up phase of  $V_{IO}$ . During  $V_{CC}$  and  $V_{IO}$  power down, it is required that  $V_{IO} \geq V_{CC}$  during the ramp down phase of  $V_{IO}$  (see [Figure 5-1](#)).
- (3) The minimum supply voltage is defined by the supervisor SVS levels when it is enabled. See the [Section 5.28](#) threshold parameters for the exact values and further details.
- (4) A capacitor tolerance of ±20% or better is required.

**Recommended Operating Conditions (continued)**

		MIN	NOM	MAX	UNIT
f <sub>SYSTEM</sub>	Processor frequency (maximum MCLK frequency) <sup>(5)</sup> (see Figure 5-3)	PMMCOREVx = 0 (default condition), 1.8 V ≤ V <sub>CC</sub> ≤ 3.6 V	0	8	MHz
		PMMCOREVx = 1, 2.0 V ≤ V <sub>CC</sub> ≤ 3.6 V	0	12	
		PMMCOREVx = 2, 2.2 V ≤ V <sub>CC</sub> ≤ 3.6 V	0	20	
		PMMCOREVx = 3, 2.4 V ≤ V <sub>CC</sub> ≤ 3.6 V	0	25	

(5) Modules may have a different maximum input clock specification. See the specification of the respective module in this data sheet.

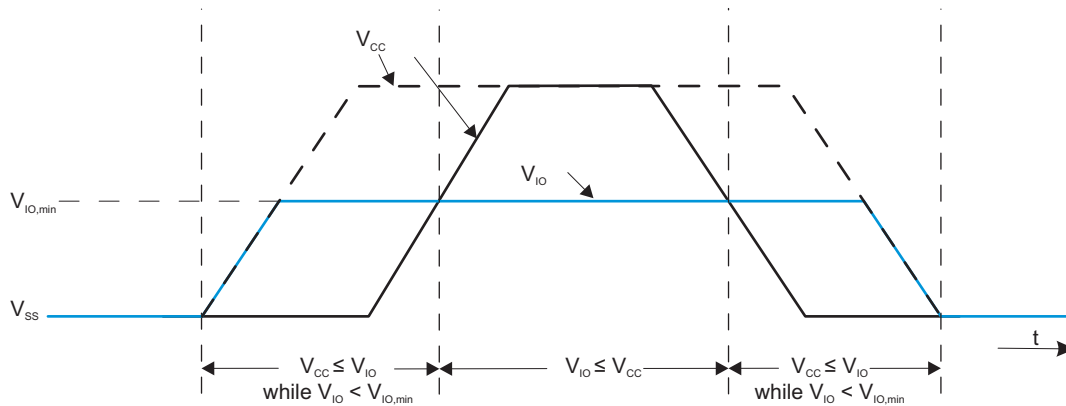

NOTE: The device supports continuous operation with V<sub>CC</sub> = V<sub>SS</sub> while V<sub>IO</sub> is fully within its specification. During this time, the general-purpose I/Os that reside on the V<sub>IO</sub> supply domain are configured as inputs and pulled down to V<sub>SS</sub> through their internal pulldown resistors.  $\overline{\text{RST}}/\text{NMI}$  is high impedance. BSLEN is configured as an input and is pulled down to V<sub>SS</sub> through its internal pulldown resistor. When V<sub>CC</sub> reaches above the BOR threshold, the general-purpose I/Os become high-impedance inputs (no resistor enabled),  $\overline{\text{RST}}/\text{NMI}$  becomes an input pulled up to V<sub>IO</sub> through its internal pullup resistor, and BSLEN remains pulled down to V<sub>SS</sub> through its internal pulldown resistor.

NOTE: Under certain conditions during the rising transition of V<sub>CC</sub>, the general-purpose I/Os residing on the V<sub>IO</sub> supply domain may actively transition high momentarily before settling to high-impedance inputs. These voltage transitions are temporary (typically resolving to high-impedance inputs when V<sub>CC</sub> exceeds approximately 0.9 V) and are bounded by the V<sub>IO</sub> supply.

**Figure 5-1. V<sub>CC</sub> and V<sub>IO</sub> Power Sequencing**

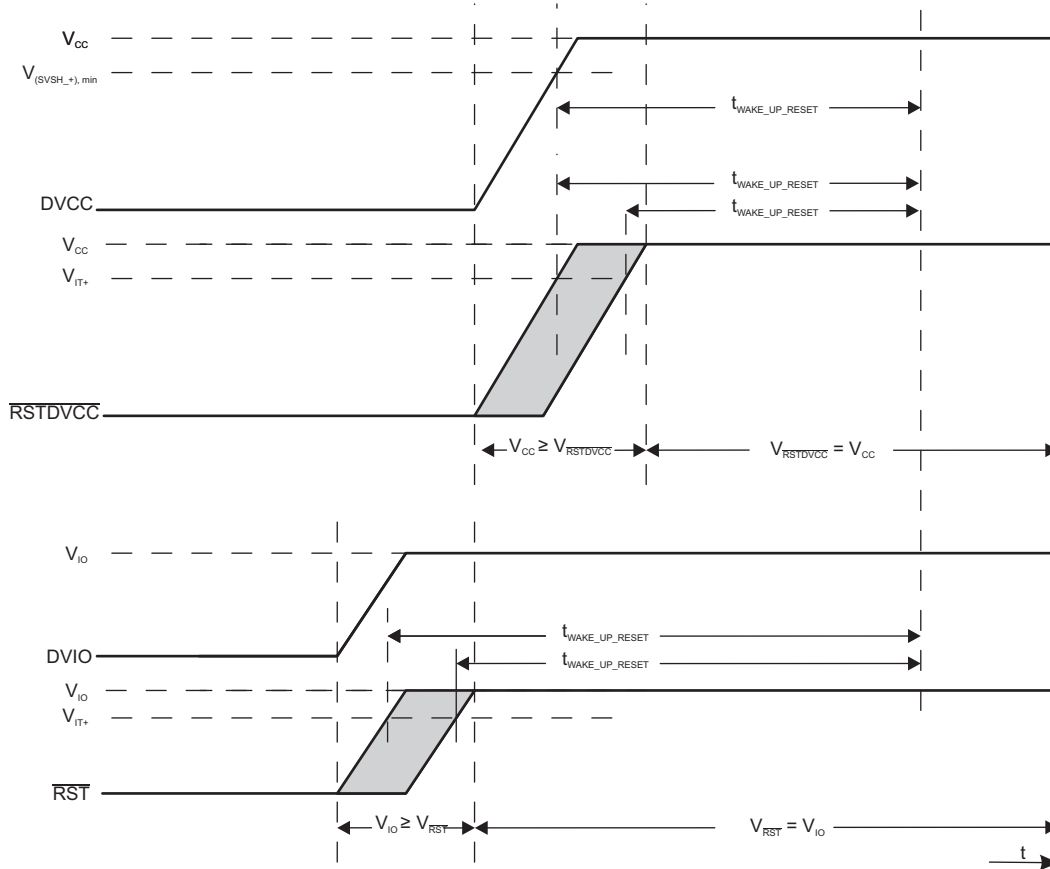

NOTE: The device remains in reset based on the conditions of the  $\overline{\text{RSTDVCC}}$  and  $\overline{\text{RST}}$  pins and the voltage present on DVCC voltage supply. If  $\overline{\text{RSTDVCC}}$  or  $\overline{\text{RST}}$  is held at a logic low or if DVCC is below the SVSH<sub>+</sub> minimum threshold, the device remains in its reset condition; that is, these conditions form a logical OR with respect to device reset.

Figure 5-2. Reset Timing

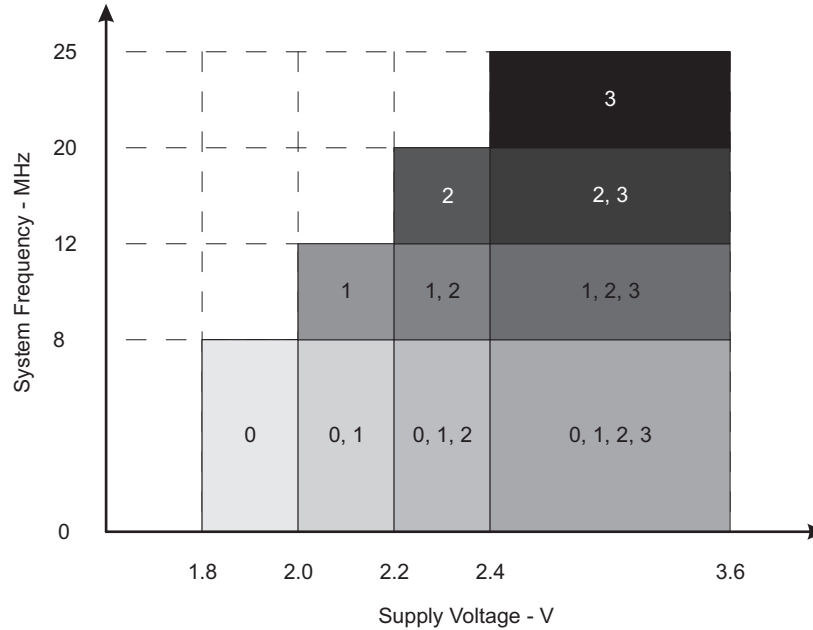

NOTE: The numbers within the fields denote the supported PMMCOREVx settings.

**Figure 5-3. Maximum System Frequency**

#### 5.4 Active Mode Supply Current Into $V_{CC}$ Excluding External Current

over recommended operating free-air temperature (unless otherwise noted)<sup>(1) (2) (3)</sup>

PARAMETER	EXECUTION MEMORY	$V_{CC}$	PMMCOREVx	FREQUENCY ( $f_{DCO} = f_{MCLK} = f_{SMCLK}$ )										UNIT
				1 MHz		8 MHz		12 MHz		20 MHz		25 MHz		
				TYP	MAX	TYP	MAX	TYP	MAX	TYP	MAX	TYP	MAX	
$I_{AM, Flash}$	Flash	3.0 V	0	0.36	0.47	2.32	2.60							mA
			1	0.40		2.65		4.0	4.4					
			2	0.44		2.90		4.3		7.1	7.7			
			3	0.46		3.10		4.6		7.6		10.1	11.0	
$I_{AM, RAM}$	RAM	3.0 V	0	0.20	0.29	1.20	1.30							mA
			1	0.22		1.35		2.0	2.2					
			2	0.24		1.50		2.2		3.7	4.2			
			3	0.26		1.60		2.4		3.9		5.3	6.2	

(1) All inputs are tied to 0 V or to  $V_{CC}$ . Outputs do not source or sink any current.

(2) The currents are characterized with a Micro Crystal MS1V-T1K crystal with a load capacitance of 12.5 pF. The internal and external load capacitance are chosen to closely match the required 12.5 pF.

(3) Characterized with program executing typical data processing.

$f_{ACLK} = 32786$  Hz,  $f_{DCO} = f_{MCLK} = f_{SMCLK}$  at specified frequency.

XTS = CPUOFF = SCG0 = SCG1 = OSCOFF = SMCLKOFF = 0.

## 5.5 Low-Power Mode Supply Currents (Into $V_{CC}$ ) Excluding External Current

 over recommended ranges of supply voltage and operating free-air temperature (unless otherwise noted)<sup>(1)(2)</sup>

PARAMETER	$V_{CC}$	PMMCOREVx	-40°C		25°C		60°C		85°C		UNIT
			TYP	MAX	TYP	MAX	TYP	MAX	TYP	MAX	
$I_{LPM0,1MHz}$ Low-power mode 0 <sup>(3)(4)</sup>	2.2 V	0	73		77	91	80		85	97	$\mu A$
	3.0 V	3	79		83	99	88		95	107	
$I_{LPM2}$ Low-power mode 2 <sup>(5)(4)</sup>	2.2 V	0	6.5		6.5	12	10		11	17	$\mu A$
	3.0 V	3	7.0		7.0	13	11		12	18	
$I_{LPM3,XT1LF}$ Low-power mode 3, crystal mode <sup>(6)(4)</sup>	2.2 V	0	1.60		1.90		2.8		6.0		$\mu A$
		1	1.65		2.00		3.0		6.3		
		2	1.75		2.15		3.2		6.6		
	3.0 V	0	1.8		2.1	2.9	3.0		6.2	9.4	
		1	1.9		2.3		3.2		6.5		
		2	2.0		2.4		3.3		6.8		
$I_{LPM3,VLO}$ Low-power mode 3, VLO mode <sup>(7)(4)</sup>	3.0 V	3	2.0		2.5	3.9	3.4		6.8	10.9	
		0	1.1		1.4	2.7	2.0		6.1	9.7	
		1	1.1		1.4		2.2		6.4		
		2	1.2		1.5		2.3		6.8		
$I_{LPM4}$ Low-power mode 4 <sup>(8)(4)</sup>	3.0 V	3	1.3		1.6	3.0	2.3		6.8	10.9	
		0	0.9		1.1	1.5	2.0		5.1	8.8	
		1	1.1		1.2		2.1		5.3		
$I_{LPM4}$ Low-power mode 4 <sup>(8)(4)</sup>	3.0 V	2	1.2		1.2		2.2		5.5		
		3	1.3		1.3	1.6	2.2		5.5	9.8	
		0	0.15		0.18	0.35	0.26		0.5	1.0	
$I_{DVIO\_START}$ Current supplied from DVIO while DVCC = AVCC = 0 V, DVIO = 1.62 V to 1.98 V, All DVIO I/O floating including BSLN and RST/NMI	0 V		1.8		1.8		1.8		1.8		$\mu A$

- (1) All inputs are tied to 0 V or to  $V_{CC}$ . Outputs do not source or sink any current.
- (2) The currents are characterized with a Micro Crystal MS1V-T1K crystal with a load capacitance of 12.5 pF. The internal and external load capacitance are chosen to closely match the required 12.5 pF.
- (3) Current for the watchdog timer clocked by SMCLK included. ACLK = low-frequency crystal operation (XTS = 0, XT1DRIVEx = 0). CPUOFF = 1, SCG0 = 0, SCG1 = 0, OSCOFF = 0 (LPM0),  $f_{ACLK} = 32768$  Hz,  $f_{MCLK} = 0$  MHz,  $f_{SMCLK} = f_{DCO} = 1$  MHz
- (4) Current for brownout and high-side supervisor (SVSH) normal mode included. Low-side supervisor (SVSL) and low-side monitor (SVM<sub>L</sub>) disabled. High-side monitor (SVM<sub>H</sub>) disabled. RAM retention enabled.
- (5) Current for watchdog timer and RTC clocked by ACLK included. ACLK = low-frequency crystal operation (XTS = 0, XT1DRIVEx = 0). CPUOFF = 1, SCG0 = 0, SCG1 = 1, OSCOFF = 0 (LPM2),  $f_{ACLK} = 32768$  Hz,  $f_{MCLK} = 0$  MHz,  $f_{SMCLK} = f_{DCO} = 0$  MHz; DCO setting = 1 MHz operation, DCO bias generator enabled.)
- (6) Current for watchdog timer and RTC clocked by ACLK included. ACLK = low-frequency crystal operation (XTS = 0, XT1DRIVEx = 0). CPUOFF = 1, SCG0 = 1, SCG1 = 1, OSCOFF = 0 (LPM3),  $f_{ACLK} = 32768$  Hz,  $f_{MCLK} = f_{SMCLK} = f_{DCO} = 0$  MHz
- (7) Current for watchdog timer and RTC clocked by ACLK included. ACLK = VLO. CPUOFF = 1, SCG0 = 1, SCG1 = 1, OSCOFF = 0 (LPM3),  $f_{ACLK} = f_{VLO}$ ,  $f_{MCLK} = f_{SMCLK} = f_{DCO} = 0$  MHz
- (8) CPUOFF = 1, SCG0 = 1, SCG1 = 1, OSCOFF = 1 (LPM4),  $f_{DCO} = f_{ACLK} = f_{MCLK} = f_{SMCLK} = 0$  MHz
- (9) Internal regulator disabled. No data retention. CPUOFF = 1, SCG0 = 1, SCG1 = 1, OSCOFF = 1, PMMREGOFF = 1 (LPM4.5),  $f_{DCO} = f_{ACLK} = f_{MCLK} = f_{SMCLK} = 0$  MHz

## 5.6 Thermal Resistance Characteristics

THERMAL METRIC <sup>(1)</sup>		VALUE <sup>(2)</sup>	UNIT	
R <sub>θJA</sub>	Junction-to-ambient thermal resistance, still air	VQFN 48 (RGZ)	27.8	°C/W
		VQFN 64 (RGC)	29.6	
		DSBGA 64 (YFF)	44.3	
		BGA 80 (ZQE)	35.2	
R <sub>θJC(TOP)</sub>	Junction-to-case (top) thermal resistance	VQFN 48 (RGZ)	13.6	°C/W
		VQFN 64 (RGC)	14.8	
		DSBGA 64 (YFF)	0.2	
		BGA 80 (ZQE)	17.6	
R <sub>θJC(BOTTOM)</sub>	Junction-to-case (bottom) thermal resistance	VQFN 48 (RGZ)	0.9	°C/W
		VQFN 64 (RGC)	1.4	
		DSBGA 64 (YFF)	N/A <sup>(3)</sup>	
		BGA 80 (ZQE)	N/A	
R <sub>θJB</sub>	Junction-to-board thermal resistance	VQFN 48 (RGZ)	4.7	°C/W
		VQFN 64 (RGC)	8.5	
		DSBGA 64 (YFF)	6.0	
		BGA 80 (ZQE)	16.7	
Ψ <sub>JT</sub>	Junction-to-package-top thermal characterization parameter	VQFN 48 (RGZ)	0.2	°C/W
		VQFN 64 (RGC)	0.2	
		DSBGA 64 (YFF)	0.6	
		BGA 80 (ZQE)	0.3	
Ψ <sub>JB</sub>	Junction-to-board thermal characterization parameter	VQFN 48 (RGZ)	4.7	°C/W
		VQFN 64 (RGC)	8.4	
		DSBGA 64 (YFF)	6.0	
		BGA 80 (ZQE)	9.6	

- (1) For more information about traditional and new thermal metrics, see [Semiconductor and IC Package Thermal Metrics](#).
- (2) These values are based on a JEDEC-defined 2S2P system (with the exception of the Theta JC [R<sub>θJC</sub>] value, which is based on a JEDEC-defined 1S0P system) and will change based on environment as well as application. For more information, see these EIA/JEDEC standards:
- JESD51-2, *Integrated Circuits Thermal Test Method Environmental Conditions - Natural Convection (Still Air)*
  - JESD51-3, *Low Effective Thermal Conductivity Test Board for Leaded Surface Mount Packages*
  - JESD51-7, *High Effective Thermal Conductivity Test Board for Leaded Surface Mount Packages*
  - JESD51-9, *Test Boards for Area Array Surface Mount Package Thermal Measurements*
- (3) N/A = not applicable

### 5.7 Schmitt-Trigger Inputs – General-Purpose I/O DVCC Domain<sup>(1)</sup> (P1.0 to P1.3, P5.0 to P5.5, P6.0 to P6.7, PJ.0 to PJ.3, RSTDVCC)

over recommended ranges of supply voltage and operating free-air temperature (unless otherwise noted)

PARAMETER		TEST CONDITIONS	V <sub>CC</sub>	MIN	TYP	MAX	UNIT
V <sub>IT+</sub>	Positive-going input threshold voltage		1.8 V	0.80		1.40	V
			3 V	1.50		2.10	
V <sub>IT-</sub>	Negative-going input threshold voltage		1.8 V	0.45		1.00	V
			3 V	0.75		1.65	
V <sub>hys</sub>	Input voltage hysteresis (V <sub>IT+</sub> – V <sub>IT-</sub> )		1.8 V	0.3		0.8	V
			3 V	0.4		1.0	
R <sub>Pull</sub>	Pullup or pulldown resistor <sup>(2)</sup>	For pullup: V <sub>IN</sub> = V <sub>SS</sub> , For pulldown: V <sub>IN</sub> = V <sub>CC</sub>		20	35	50	kΩ
C <sub>I</sub>	Input capacitance	V <sub>IN</sub> = V <sub>SS</sub> or V <sub>CC</sub>			5		pF

(1) Same parametrics apply to clock input pin when crystal bypass mode is used on XT1 (XIN) or XT2 (XT2IN).

(2) RSTDVCC has a fixed pullup resistor that cannot be disabled.

### 5.8 Schmitt-Trigger Inputs – General-Purpose I/O DVIO Domain (P1.4 to P1.7, P2.0 to P2.7, P3.0 to P3.4, P4.0 to P4.7, P7.0 to P7.5, $\overline{\text{RST}}$ /NMI, BLEN)

over recommended ranges of supply voltage and operating free-air temperature (unless otherwise noted)

PARAMETER		TEST CONDITIONS	V <sub>IO</sub>	MIN	TYP	MAX	UNIT
V <sub>IT+</sub>	Positive-going input threshold voltage	V <sub>CC</sub> = 3.0 V	1.62 V	0.8		1.25	V
			1.98 V	1.1		1.40	
V <sub>IT-</sub>	Negative-going input threshold voltage	V <sub>CC</sub> = 3.0 V	1.62 V	0.3		0.7	V
			1.98 V	0.5		1.0	
V <sub>hys</sub>	Input voltage hysteresis (V <sub>IT+</sub> – V <sub>IT-</sub> )	V <sub>CC</sub> = 3.0 V	1.62 V to 1.98 V	0.3		0.8	V
R <sub>Pull</sub>	Pullup or pulldown resistor <sup>(1)</sup>	For pullup: V <sub>IN</sub> = V <sub>SS</sub> , For pulldown: V <sub>IN</sub> = V <sub>IO</sub>		20	35	50	kΩ
C <sub>I</sub>	Input capacitance	V <sub>IN</sub> = V <sub>SS</sub> or V <sub>IO</sub>			5		pF

(1) Also applies to  $\overline{\text{RST}}$  pin when pullup or pulldown resistor is enabled.

### 5.9 Inputs – Interrupts DVCC Domain Port P1 (P1.0 to P1.3)

over recommended ranges of supply voltage and operating free-air temperature (unless otherwise noted)

PARAMETER	TEST CONDITIONS	V <sub>CC</sub>	MIN	MAX	UNIT
t <sub>(int)</sub>	External interrupt timing <sup>(1)</sup>	External trigger pulse duration to set interrupt flag	1.8 V, 3 V	20	ns

(1) An external signal sets the interrupt flag every time the minimum interrupt pulse duration t<sub>(int)</sub> is met. It may be set by trigger signals shorter than t<sub>(int)</sub>.

### 5.10 Inputs – Interrupts DVIO Domain Ports P1 and P2 (P1.4 to P1.7, P2.0 to P2.7)

over recommended ranges of supply voltage and operating free-air temperature (unless otherwise noted)

PARAMETER	TEST CONDITIONS	V <sub>IO</sub> <sup>(1)</sup>	MIN	MAX	UNIT
t <sub>(int)</sub>	External interrupt timing <sup>(2)</sup>	External trigger pulse duration to set interrupt flag, V <sub>CC</sub> = 1.8 V or 3.0 V	1.62 V to 1.98 V	20	ns

(1) In all test conditions, V<sub>IO</sub> ≤ V<sub>CC</sub>.

(2) An external signal sets the interrupt flag every time the minimum interrupt pulse duration t<sub>(int)</sub> is met. It may be set by trigger signals shorter than t<sub>(int)</sub>.

### 5.11 Leakage Current – General-Purpose I/O DVCC Domain (P1.0 to P1.3, P5.0 to P5.5, P6.0 to P6.7, PJ.0 to PJ.3)

over recommended ranges of supply voltage and operating free-air temperature (unless otherwise noted)

PARAMETER	TEST CONDITIONS	V <sub>CC</sub>	MIN	MAX	UNIT
I <sub>lkg</sub> (Px.y) High-impedance leakage current	(1) (2)	1.8 V, 3 V	-50	50	nA

(1) The leakage current is measured with V<sub>SS</sub> or V<sub>CC</sub> applied to the corresponding pins, unless otherwise noted.

(2) The leakage of the digital port pins is measured individually. The port pin is selected for input and the pullup or pulldown resistor is disabled.

### 5.12 Leakage Current – General-Purpose I/O DVIO Domain (P1.4 to P1.7, P2.0 to P2.7, P3.0 to P3.4, P4.0 to P4.7, P7.0 to P7.5)

over recommended ranges of supply voltage and operating free-air temperature (unless otherwise noted)

PARAMETER	TEST CONDITIONS	V <sub>IO</sub> (1)	MIN	MAX	UNIT
I <sub>lkg</sub> (Px.y) High-impedance leakage current	(2) (3)	1.62 V to 1.98 V	-50	50	nA

(1) In all test conditions, V<sub>IO</sub> ≤ V<sub>CC</sub>.

(2) The leakage current is measured with V<sub>SS</sub> or V<sub>IO</sub> applied to the corresponding pins, unless otherwise noted.

(3) The leakage of the digital port pins is measured individually. The port pin is selected for input and the pullup or pulldown resistor is disabled.

### 5.13 Outputs – General-Purpose I/O DVCC Domain (Full Drive Strength) (P1.0 to P1.3, P5.0 to P5.5, P6.0 to P6.7, PJ.0 to PJ.3)

over recommended ranges of supply voltage and operating free-air temperature (unless otherwise noted)

PARAMETER	TEST CONDITIONS	V <sub>CC</sub>	MIN	MAX	UNIT
V <sub>OH</sub> High-level output voltage	I <sub>(OHmax)</sub> = -3 mA (1)	1.8 V	V <sub>CC</sub> - 0.25	V <sub>CC</sub>	V
	I <sub>(OHmax)</sub> = -10 mA (2)		V <sub>CC</sub> - 0.60	V <sub>CC</sub>	
	I <sub>(OHmax)</sub> = -5 mA (1)	3 V	V <sub>CC</sub> - 0.25	V <sub>CC</sub>	
	I <sub>(OHmax)</sub> = -15 mA (2)		V <sub>CC</sub> - 0.60	V <sub>CC</sub>	
V <sub>OL</sub> Low-level output voltage	I <sub>(OLmax)</sub> = 3 mA (1)	1.8 V	V <sub>SS</sub>	V <sub>SS</sub> + 0.25	V
	I <sub>(OLmax)</sub> = 10 mA (2)		V <sub>SS</sub>	V <sub>SS</sub> + 0.60	
	I <sub>(OLmax)</sub> = 5 mA (1)	3 V	V <sub>SS</sub>	V <sub>SS</sub> + 0.25	
	I <sub>(OLmax)</sub> = 15 mA (2)		V <sub>SS</sub>	V <sub>SS</sub> + 0.60	

(1) The maximum total current, I<sub>(OHmax)</sub> and I<sub>(OLmax)</sub>, for all outputs combined should not exceed ±48 mA to hold the maximum voltage drop specified.

(2) The maximum total current, I<sub>(OHmax)</sub> and I<sub>(OLmax)</sub>, for all outputs combined should not exceed ±100 mA to hold the maximum voltage drop specified.

### 5.14 Outputs – General-Purpose I/O DVCC Domain (Reduced Drive Strength) (P1.0 to P1.3, P5.0 to P5.5, P6.0 to P6.7, PJ.0 to PJ.3)

over recommended ranges of supply voltage and operating free-air temperature (unless otherwise noted) (1)

PARAMETER	TEST CONDITIONS	V <sub>CC</sub>	MIN	MAX	UNIT
V <sub>OH</sub> High-level output voltage	I <sub>(OHmax)</sub> = -1 mA (2)	1.8 V	V <sub>CC</sub> - 0.25	V <sub>CC</sub>	V
	I <sub>(OHmax)</sub> = -3 mA (3)		V <sub>CC</sub> - 0.60	V <sub>CC</sub>	
	I <sub>(OHmax)</sub> = -2 mA (2)	3.0 V	V <sub>CC</sub> - 0.25	V <sub>CC</sub>	
	I <sub>(OHmax)</sub> = -6 mA (3)		V <sub>CC</sub> - 0.60	V <sub>CC</sub>	
V <sub>OL</sub> Low-level output voltage	I <sub>(OLmax)</sub> = 1 mA (2)	1.8 V	V <sub>SS</sub>	V <sub>SS</sub> + 0.25	V
	I <sub>(OLmax)</sub> = 3 mA (3)		V <sub>SS</sub>	V <sub>SS</sub> + 0.60	
	I <sub>(OLmax)</sub> = 2 mA (2)	3.0 V	V <sub>SS</sub>	V <sub>SS</sub> + 0.25	
	I <sub>(OLmax)</sub> = 6 mA (3)		V <sub>SS</sub>	V <sub>SS</sub> + 0.60	

(1) Selecting reduced drive strength may reduce EMI.

(2) The maximum total current, I<sub>(OHmax)</sub> and I<sub>(OLmax)</sub>, for all outputs combined, should not exceed ±48 mA to hold the maximum voltage drop specified.

(3) The maximum total current, I<sub>(OHmax)</sub> and I<sub>(OLmax)</sub>, for all outputs combined, should not exceed ±100 mA to hold the maximum voltage drop specified.

### 5.15 Outputs – General-Purpose I/O DVIO Domain (Full Drive Strength) (P1.4 to P1.7, P2.0 to P2.7, P3.0 to P3.4, P4.0 to P4.7, P7.0 to P7.5)

over recommended ranges of supply voltage and operating free-air temperature (unless otherwise noted)

PARAMETER		TEST CONDITIONS	$V_{IO}^{(1)}$	MIN	MAX	UNIT
$V_{OH}$	High-level output voltage	$I_{(OHmax)} = -3 \text{ mA}^{(2)}$	1.62 V to 1.98 V	$V_{IO} - 0.25$	$V_{IO}$	V
		$I_{(OHmax)} = -6 \text{ mA}^{(2)}$		$V_{IO} - 0.50$	$V_{IO}$	
$V_{OL}$	Low-level output voltage	$I_{(OLmax)} = 3 \text{ mA}^{(2)}$	1.62 V to 1.98 V	$V_{SS}$	$V_{SS} + 0.25$	V
		$I_{(OLmax)} = 6 \text{ mA}^{(2)}$		$V_{SS}$	$V_{SS} + 0.50$	

(1) In all test conditions,  $V_{IO} \leq V_{CC}$ .

(2) The maximum total current,  $I_{(OHmax)}$  and  $I_{(OLmax)}$ , for all outputs combined, should not exceed  $\pm 48 \text{ mA}$  to hold the maximum voltage drop specified.

### 5.16 Outputs – General-Purpose I/O DVIO Domain (Reduced Drive Strength) (P1.4 to P1.7, P2.0 to P2.7, P3.0 to P3.4, P4.0 to P4.7, P7.0 to P7.5)

over recommended ranges of supply voltage and operating free-air temperature (unless otherwise noted)<sup>(1)</sup>

PARAMETER		TEST CONDITIONS	$V_{IO}^{(2)}$	MIN	MAX	UNIT
$V_{OH}$	High-level output voltage	$I_{(OHmax)} = -1 \text{ mA}^{(3)}$	1.62 V to 1.98 V	$V_{IO} - 0.25$	$V_{IO}$	V
		$I_{(OHmax)} = -2 \text{ mA}^{(3)}$		$V_{IO} - 0.50$	$V_{IO}$	
$V_{OL}$	Low-level output voltage	$I_{(OLmax)} = 1 \text{ mA}^{(3)}$	1.62 V to 1.98 V	$V_{SS}$	$V_{SS} + 0.25$	V
		$I_{(OLmax)} = 2 \text{ mA}^{(3)}$		$V_{SS}$	$V_{SS} + 0.50$	

(1) Selecting reduced drive strength may reduce EMI.

(2) In all test conditions,  $V_{IO} \leq V_{CC}$ .

(3) The maximum total current,  $I_{(OHmax)}$  and  $I_{(OLmax)}$ , for all outputs combined, should not exceed  $\pm 48 \text{ mA}$  to hold the maximum voltage drop specified.

### 5.17 Output Frequency – General-Purpose I/O DVCC Domain (P1.0 to P1.3, P5.0 to P5.5, P6.0 to P6.7, PJ.0 to PJ.3)

over recommended ranges of supply voltage and operating free-air temperature (unless otherwise noted)

PARAMETER		TEST CONDITIONS		MIN	MAX	UNIT
f <sub>Px,y</sub>	Port output frequency (with load)	(1)(2)	V <sub>CC</sub> = 1.8 V, PMMCOREVx = 0		16	MHz
			V <sub>CC</sub> = 3 V, PMMCOREVx = 3		25	
f <sub>Port_CLK</sub>	Clock output frequency	ACLK, SMCLK, or MCLK, C <sub>L</sub> = 20 pF <sup>(2)</sup>	V <sub>CC</sub> = 1.8 V, PMMCOREVx = 0		16	MHz
			V <sub>CC</sub> = 3 V, PMMCOREVx = 3		25	

- (1) A resistive divider with 2 × R1 between V<sub>CC</sub> and V<sub>SS</sub> is used as load. The output is connected to the center tap of the divider. For full drive strength, R1 = 550 Ω. For reduced drive strength, R1 = 1.6 kΩ. C<sub>L</sub> = 20 pF is connected to the output to V<sub>SS</sub>.
- (2) The output voltage reaches at least 10% and 90% V<sub>CC</sub> at the specified toggle frequency.

### 5.18 Output Frequency – General-Purpose I/O DVIO Domain (P1.4 to P1.7, P2.0 to P2.7, P3.0 to P3.4, P4.0 to P4.7, P7.0 to P7.5)

over recommended ranges of supply voltage and operating free-air temperature (unless otherwise noted)

PARAMETER		TEST CONDITIONS		MIN	MAX	UNIT
f <sub>Px,y</sub>	Port output frequency (with load)	(1)(2)	V <sub>IO</sub> = 1.62 V to 1.98 V <sup>(3)</sup> , PMMCOREVx = 0		16	MHz
			V <sub>IO</sub> = 1.62 V to 1.98 V <sup>(3)</sup> , PMMCOREVx = 3		25	
f <sub>Port_CLK</sub>	Clock output frequency	ACLK, SMCLK, or MCLK, C <sub>L</sub> = 20 pF <sup>(2)</sup>	V <sub>IO</sub> = 1.62 V to 1.98 V <sup>(3)</sup> , PMMCOREVx = 0		16	MHz
			V <sub>IO</sub> = 1.62 V to 1.98 V <sup>(3)</sup> , PMMCOREVx = 3		25	

- (1) A resistive divider with 2 × R1 between V<sub>IO</sub> and V<sub>SS</sub> is used as load. The output is connected to the center tap of the divider. For full drive strength, R1 = 550 Ω. For reduced drive strength, R1 = 1.6 kΩ. C<sub>L</sub> = 20 pF is connected to the output to V<sub>SS</sub>.
- (2) The output voltage reaches at least 10% and 90% V<sub>IO</sub> at the specified toggle frequency.
- (3) In all test conditions, V<sub>IO</sub> ≤ V<sub>CC</sub>.

### 5.19 Typical Characteristics – Outputs, Reduced Drive Strength (PxDS.y = 0)

over recommended ranges of supply voltage and operating free-air temperature (unless otherwise noted)

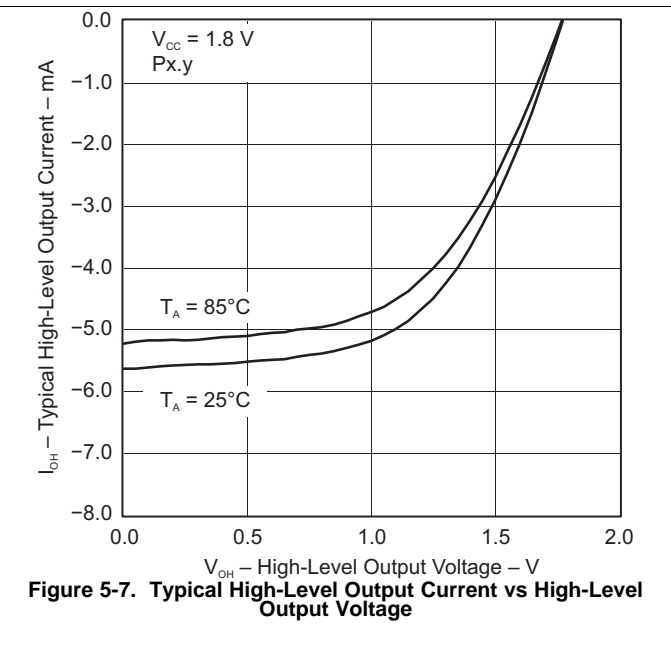
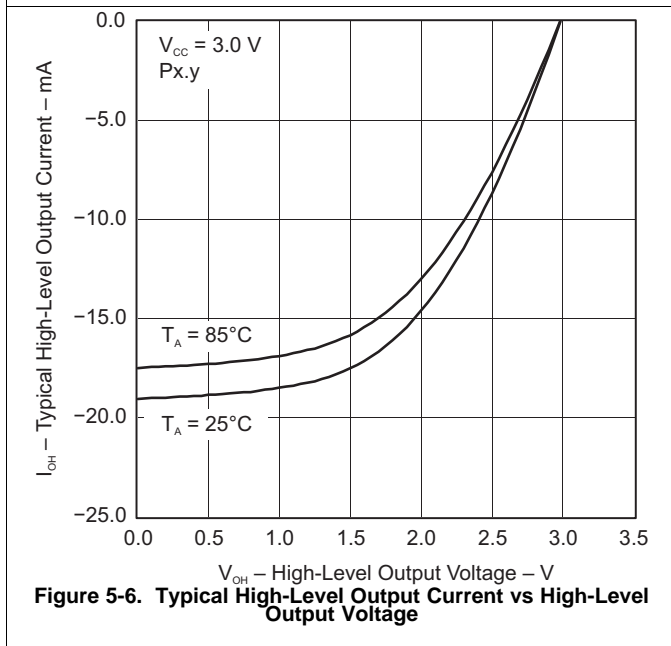
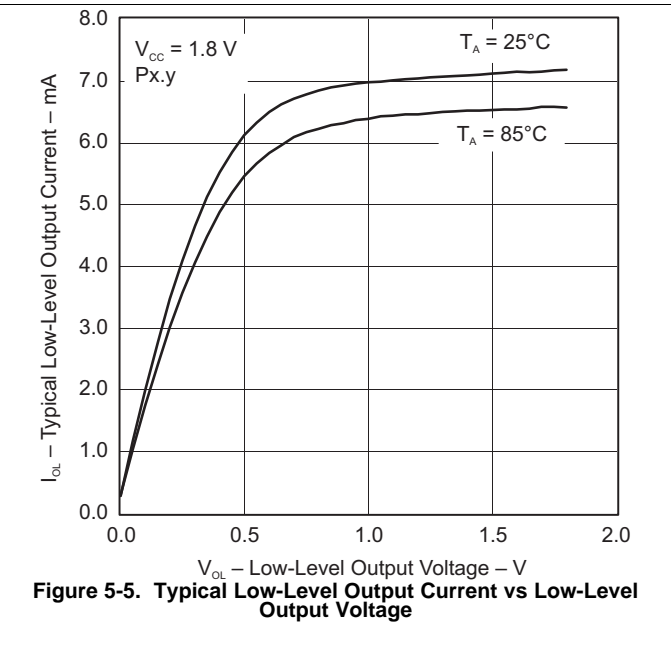
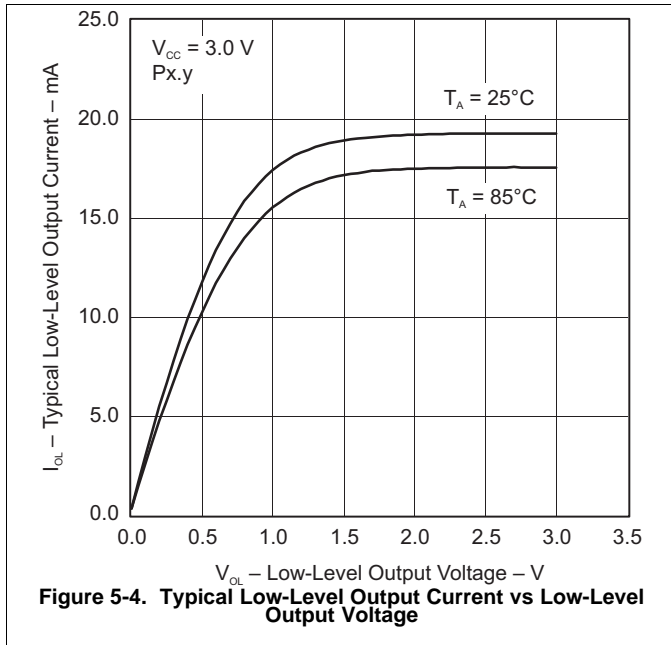

## 5.20 Typical Characteristics – Outputs, Full Drive Strength (PxDS.y = 1)

over recommended ranges of supply voltage and operating free-air temperature (unless otherwise noted)

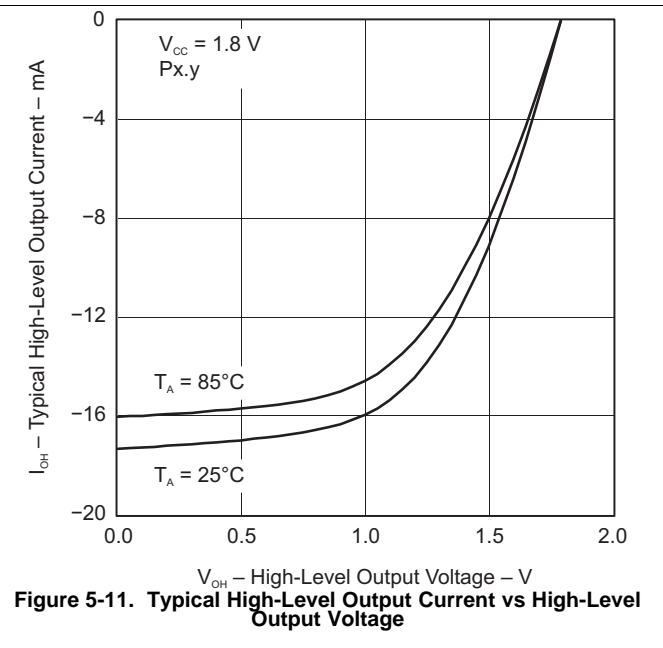
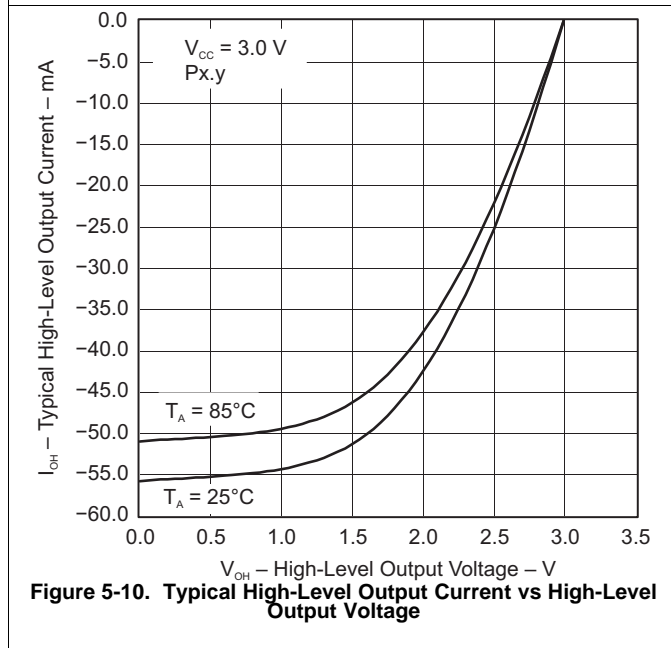
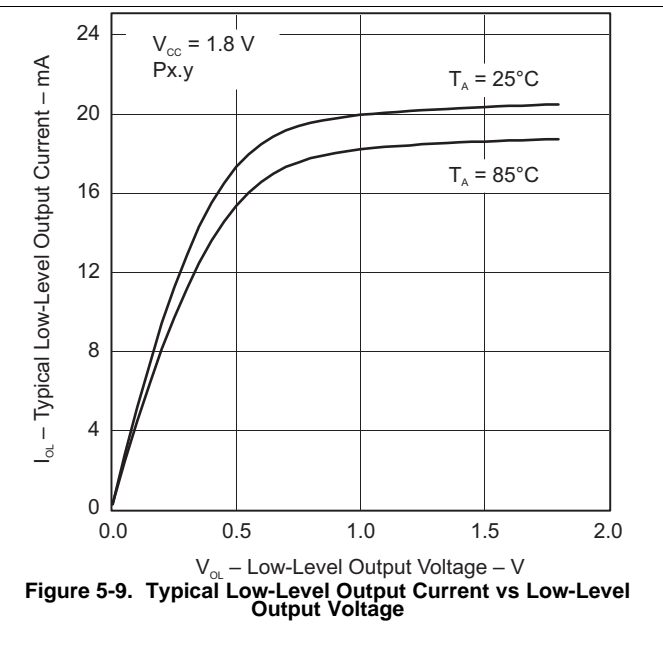
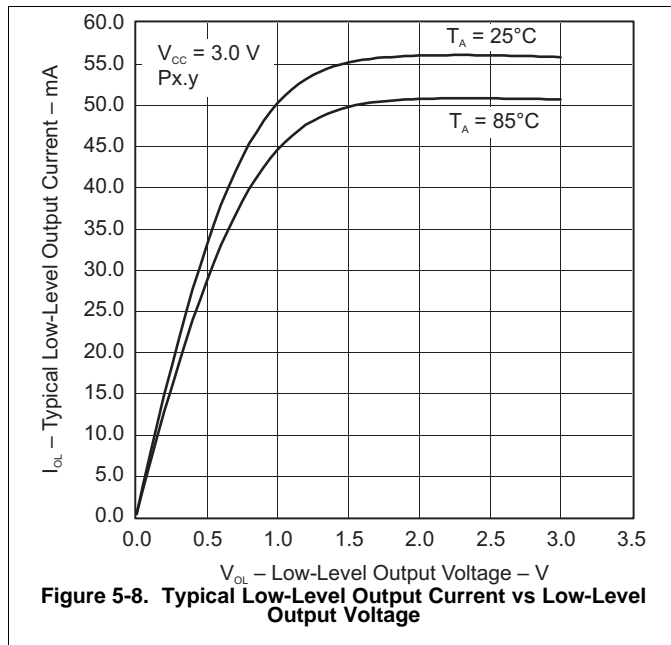

## 5.21 Crystal Oscillator, XT1, Low-Frequency Mode

over recommended ranges of supply voltage and operating free-air temperature (unless otherwise noted)<sup>(1)</sup>

PARAMETER		TEST CONDITIONS	V <sub>CC</sub>	MIN	TYP	MAX	UNIT
$\Delta I_{DVCC,LF}$	Differential XT1 oscillator crystal current consumption from lowest drive setting, LF mode	$f_{OSC} = 32768$ Hz, XTS = 0, XT1BYPASS = 0, XT1DRIVE <sub>x</sub> = 1, T <sub>A</sub> = 25°C	3.0 V	0.075		μA	
		$f_{OSC} = 32768$ Hz, XTS = 0, XT1BYPASS = 0, XT1DRIVE <sub>x</sub> = 2, T <sub>A</sub> = 25°C		0.170			
		$f_{OSC} = 32768$ Hz, XTS = 0, XT1BYPASS = 0, XT1DRIVE <sub>x</sub> = 3, T <sub>A</sub> = 25°C		0.290			
$f_{XT1,LF0}$	XT1 oscillator crystal frequency, LF mode	XTS = 0, XT1BYPASS = 0		32768		Hz	
$f_{XT1,LF,SW}$	XT1 oscillator logic-level square-wave input frequency, LF mode	XTS = 0, XT1BYPASS = 1 <sup>(2)(3)</sup> XT1BYPASSLV = 0 or 1		10	32.768	50	kHz
$OA_{LF}$	Oscillation allowance for LF crystals <sup>(4)</sup>	XTS = 0, XT1BYPASS = 0, XT1DRIVE <sub>x</sub> = 0, $f_{XT1,LF} = 32768$ Hz, C <sub>L,eff</sub> = 6 pF		210		kΩ	
		XTS = 0, XT1BYPASS = 0, XT1DRIVE <sub>x</sub> = 1, $f_{XT1,LF} = 32768$ Hz, C <sub>L,eff</sub> = 12 pF		300			
$C_{L,eff}$	Integrated effective load capacitance, LF mode <sup>(5)</sup>	XTS = 0, XCAP <sub>x</sub> = 0 <sup>(6)</sup>		1		pF	
		XTS = 0, XCAP <sub>x</sub> = 1		5.5			
		XTS = 0, XCAP <sub>x</sub> = 2		8.5			
		XTS = 0, XCAP <sub>x</sub> = 3		12.0			
	Duty cycle, LF mode	XTS = 0, Measured at ACLK, $f_{XT1,LF} = 32768$ Hz		30%		70%	
$f_{Fault,LF}$	Oscillator fault frequency, LF mode <sup>(7)</sup>	XTS = 0, XT1BYPASS = 1 <sup>(8)</sup> , XT1BYPASSLV = 0 or 1		10		10000	Hz
$t_{START,LF}$	Start-up time, LF mode	$f_{OSC} = 32768$ Hz, XTS = 0, XT1BYPASS = 0, XT1DRIVE <sub>x</sub> = 0, T <sub>A</sub> = 25°C, C <sub>L,eff</sub> = 6 pF	3.0 V	1000		ms	
		$f_{OSC} = 32768$ Hz, XTS = 0, XT1BYPASS = 0, XT1DRIVE <sub>x</sub> = 3, T <sub>A</sub> = 25°C, C <sub>L,eff</sub> = 12 pF		500			

- (1) To improve EMI on the XT1 oscillator, the following guidelines should be observed.
  - Keep the trace between the device and the crystal as short as possible.
  - Design a good ground plane around the oscillator pins.
  - Prevent crosstalk from other clock or data lines into oscillator pins XIN and XOUT.
  - Avoid running PCB traces underneath or adjacent to the XIN and XOUT pins.
  - Use assembly materials and processes that avoid any parasitic load on the oscillator XIN and XOUT pins.
  - If conformal coating is used, make sure that it does not induce capacitive or resistive leakage between the oscillator pins.
- (2) When XT1BYPASS is set, XT1 circuits are automatically powered down. Input signal is a digital square wave with parametrics defined in the [Schmitt-Trigger Inputs](#) section of this data sheet. When in crystal bypass mode, XIN can be configured so that it can support an input digital waveform with swing levels from DVSS to DVCC (XT1BYPASSLV = 0) or DVSS to DVIO (XT1BYPASSLV = 1). In this case, the pin must be configured properly for the intended input swing.
- (3) Maximum frequency of operation of the entire device cannot be exceeded.
- (4) Oscillation allowance is based on a safety factor of 5 for recommended crystals. The oscillation allowance is a function of the XT1DRIVE<sub>x</sub> settings and the effective load. In general, comparable oscillator allowance can be achieved based on the following guidelines, but each application should be evaluated based on the actual crystal selected:
  - For XT1DRIVE<sub>x</sub> = 0, C<sub>L,eff</sub> ≤ 6 pF
  - For XT1DRIVE<sub>x</sub> = 1, 6 pF ≤ C<sub>L,eff</sub> ≤ 9 pF
  - For XT1DRIVE<sub>x</sub> = 2, 6 pF ≤ C<sub>L,eff</sub> ≤ 10 pF
  - For XT1DRIVE<sub>x</sub> = 3, C<sub>L,eff</sub> ≥ 6 pF
- (5) Includes parasitic bond and package capacitance (approximately 2 pF per pin). Because the PCB adds additional capacitance, verify the correct load by measuring the ACLK frequency. For a correct setup, the effective load capacitance should always match the specification of the used crystal.
- (6) Requires external capacitors at both terminals. Values are specified by crystal manufacturers.
- (7) Frequencies below the MIN specification set the fault flag. Frequencies above the MAX specification do not set the fault flag. Frequencies between the MIN and MAX specifications might set the flag.
- (8) Measured with logic-level input frequency but also applies to operation with crystals.

## 5.22 Crystal Oscillator, XT2

over recommended ranges of supply voltage and operating free-air temperature (unless otherwise noted)<sup>(1)(2)</sup>

PARAMETER		TEST CONDITIONS	V <sub>CC</sub>	MIN	TYP	MAX	UNIT
I <sub>DVCC,XT2</sub>	XT2 oscillator crystal current consumption	f <sub>OSC</sub> = 4 MHz, XT2OFF = 0, XT2BYPASS = 0, XT2DRIVE <sub>x</sub> = 0, T <sub>A</sub> = 25°C	3.0 V		200		μA
		f <sub>OSC</sub> = 12 MHz, XT2OFF = 0, XT2BYPASS = 0, XT2DRIVE <sub>x</sub> = 1, T <sub>A</sub> = 25°C			260		
		f <sub>OSC</sub> = 20 MHz, XT2OFF = 0, XT2BYPASS = 0, XT2DRIVE <sub>x</sub> = 2, T <sub>A</sub> = 25°C			325		
		f <sub>OSC</sub> = 32 MHz, XT2OFF = 0, XT2BYPASS = 0, XT2DRIVE <sub>x</sub> = 3, T <sub>A</sub> = 25°C			450		
f <sub>XT2,HF0</sub>	XT2 oscillator crystal frequency, mode 0	XT2DRIVE <sub>x</sub> = 0, XT2BYPASS = 0 <sup>(3)</sup>		4		8	MHz
f <sub>XT2,HF1</sub>	XT2 oscillator crystal frequency, mode 1	XT2DRIVE <sub>x</sub> = 1, XT2BYPASS = 0 <sup>(3)</sup>		8		16	MHz
f <sub>XT2,HF2</sub>	XT2 oscillator crystal frequency, mode 2	XT2DRIVE <sub>x</sub> = 2, XT2BYPASS = 0 <sup>(3)</sup>		16		24	MHz
f <sub>XT2,HF3</sub>	XT2 oscillator crystal frequency, mode 3	XT2DRIVE <sub>x</sub> = 3, XT2BYPASS = 0 <sup>(3)</sup>		24		32	MHz
f <sub>XT2,HF,SW</sub>	XT2 oscillator logic-level square-wave input frequency, bypass mode	XT2BYPASS = 1 <sup>(4)(3)</sup> XT2BYPASSLV = 0 or 1		0.7		32	MHz
O <sub>AHF</sub>	Oscillation allowance for HF crystals <sup>(5)</sup>	XT2DRIVE <sub>x</sub> = 0, XT2BYPASS = 0, f <sub>XT2,HF0</sub> = 6 MHz, C <sub>L,eff</sub> = 15 pF			450		Ω
		XT2DRIVE <sub>x</sub> = 1, XT2BYPASS = 0, f <sub>XT2,HF1</sub> = 12 MHz, C <sub>L,eff</sub> = 15 pF			320		
		XT2DRIVE <sub>x</sub> = 2, XT2BYPASS = 0, f <sub>XT2,HF2</sub> = 20 MHz, C <sub>L,eff</sub> = 15 pF			200		
		XT2DRIVE <sub>x</sub> = 3, XT2BYPASS = 0, f <sub>XT2,HF3</sub> = 32 MHz, C <sub>L,eff</sub> = 15 pF			200		
t <sub>START,HF</sub>	Start-up time	f <sub>OSC</sub> = 6 MHz, XT2BYPASS = 0, XT2DRIVE <sub>x</sub> = 0, T <sub>A</sub> = 25°C, C <sub>L,eff</sub> = 15 pF	3.0 V		0.5		ms
		f <sub>OSC</sub> = 20 MHz, XT2BYPASS = 0, XT2DRIVE <sub>x</sub> = 2, T <sub>A</sub> = 25°C, C <sub>L,eff</sub> = 15 pF			0.3		
C <sub>L,eff</sub>	Integrated effective load capacitance, HF mode <sup>(6) (1)</sup>				1		pF
		Duty cycle	Measured at ACLK, f <sub>XT2,HF2</sub> = 20 MHz	40%	50%	60%	

(1) Requires external capacitors at both terminals. Values are specified by crystal manufacturers.

(2) To improve EMI on the XT2 oscillator the following guidelines should be observed.

- Keep the traces between the device and the crystal as short as possible.
- Design a good ground plane around the oscillator pins.
- Prevent crosstalk from other clock or data lines into oscillator pins XT2IN and XT2OUT.
- Avoid running PCB traces underneath or adjacent to the XT2IN and XT2OUT pins.
- Use assembly materials and processes that avoid any parasitic load on the oscillator XT2IN and XT2OUT pins.
- If conformal coating is used, make sure that it does not induce capacitive or resistive leakage between the oscillator pins.

(3) This represents the maximum frequency that can be input to the device externally. Maximum frequency achievable on the device operation is based on the frequencies present on ACLK, MCLK, and SMCLK cannot be exceed for a given range of operation.

(4) When XT2BYPASS is set, the XT2 circuit is automatically powered down. Input signal is a digital square wave with parametrics defined in the Schmitt-trigger Inputs section of this data sheet. When in crystal bypass mode, XT2IN can be configured so that it can support an input digital waveform with swing levels from DVSS to DVCC (XT2BYPASSLV = 0) or DVSS to DVIO (XT2BYPASSLV = 1). In this case, it is required that the pin be configured properly for the intended input swing.

(5) Oscillation allowance is based on a safety factor of 5 for recommended crystals.

(6) Includes parasitic bond and package capacitance (approximately 2 pF per pin).

Because the PCB adds additional capacitance, verify the correct load by measuring the ACLK frequency. For a correct setup, the effective load capacitance should always match the specification of the used crystal.

## Crystal Oscillator, XT2 (continued)

over recommended ranges of supply voltage and operating free-air temperature (unless otherwise noted)<sup>(1)(2)</sup>

PARAMETER		TEST CONDITIONS	V <sub>CC</sub>	MIN	TYP	MAX	UNIT
f <sub>Fault,HF</sub>	Oscillator fault frequency <sup>(7)</sup>	XT2BYPASS = 1 <sup>(8)</sup> , XT2BYPASSLV = 0 or 1		30		300	kHz

(7) Frequencies below the MIN specification set the fault flag. Frequencies above the MAX specification do not set the fault flag. Frequencies between the MIN and MAX specifications might set the flag.

(8) Measured with logic-level input frequency but also applies to operation with crystals. In general, an effective load capacitance of up to 18 pF can be supported.

## 5.23 Internal Very-Low-Power Low-Frequency Oscillator (VLO)

over recommended ranges of supply voltage and operating free-air temperature (unless otherwise noted)

PARAMETER		TEST CONDITIONS	V <sub>CC</sub>	MIN	TYP	MAX	UNIT
f <sub>VLO</sub>	VLO frequency	Measured at ACLK	1.8 V to 3.6 V	6	9.4	14	kHz
df <sub>VLO</sub> /dT	VLO frequency temperature drift	Measured at ACLK <sup>(1)</sup>	1.8 V to 3.6 V		0.5		%/°C
df <sub>VLO</sub> /dV <sub>CC</sub>	VLO frequency supply voltage drift	Measured at ACLK <sup>(2)</sup>	1.8 V to 3.6 V		4		%/V
	Duty cycle	Measured at ACLK	1.8 V to 3.6 V	40%	50%	60%	

(1) Calculated using the box method: (MAX(−40°C to 85°C) – MIN(−40°C to 85°C)) / MIN(−40°C to 85°C) / (85°C – (−40°C))

(2) Calculated using the box method: (MAX(1.8 V to 3.6 V) – MIN(1.8 V to 3.6 V)) / MIN(1.8 V to 3.6 V) / (3.6 V – 1.8 V)

## 5.24 Internal Reference, Low-Frequency Oscillator (REFO)

over recommended ranges of supply voltage and operating free-air temperature (unless otherwise noted)

PARAMETER		TEST CONDITIONS	V <sub>CC</sub>	MIN	TYP	MAX	UNIT
I <sub>REFO</sub>	REFO oscillator current consumption	T <sub>A</sub> = 25°C	1.8 V to 3.6 V		3		μA
f <sub>REFO</sub>	REFO frequency	Measured at ACLK	1.8 V to 3.6 V		32768		Hz
	REFO absolute tolerance	Full temperature range	1.8 V to 3.6 V	−3.5%		3.5%	
		T <sub>A</sub> = 25°C	3 V	−1.5%		1.5%	
df <sub>REFO</sub> /dT	REFO frequency temperature drift	Measured at ACLK <sup>(1)</sup>	1.8 V to 3.6 V		0.01		%/°C
df <sub>REFO</sub> /dV <sub>CC</sub>	REFO frequency supply voltage drift	Measured at ACLK <sup>(2)</sup>	1.8 V to 3.6 V		1.0		%/V
	Duty cycle	Measured at ACLK	1.8 V to 3.6 V	40%	50%	60%	
t <sub>START</sub>	REFO start-up time	40%/60% duty cycle	1.8 V to 3.6 V		25		μs

(1) Calculated using the box method: (MAX(−40°C to 85°C) – MIN(−40°C to 85°C)) / MIN(−40°C to 85°C) / (85°C – (−40°C))

(2) Calculated using the box method: (MAX(1.8 V to 3.6 V) – MIN(1.8 V to 3.6 V)) / MIN(1.8 V to 3.6 V) / (3.6 V – 1.8 V)

## 5.25 DCO Frequency

over recommended ranges of supply voltage and operating free-air temperature (unless otherwise noted)

PARAMETER	TEST CONDITIONS	MIN	TYP	MAX	UNIT
$f_{DCO(0,0)}$	DCO frequency (0, 0) <sup>(1)</sup>	DCORSELx = 0, DCOx = 0, MODx = 0	0.07	0.20	MHz
$f_{DCO(0,31)}$	DCO frequency (0, 31) <sup>(1)</sup>	DCORSELx = 0, DCOx = 31, MODx = 0	0.70	1.70	MHz
$f_{DCO(1,0)}$	DCO frequency (1, 0) <sup>(1)</sup>	DCORSELx = 1, DCOx = 0, MODx = 0	0.15	0.36	MHz
$f_{DCO(1,31)}$	DCO frequency (1, 31) <sup>(1)</sup>	DCORSELx = 1, DCOx = 31, MODx = 0	1.47	3.45	MHz
$f_{DCO(2,0)}$	DCO frequency (2, 0) <sup>(1)</sup>	DCORSELx = 2, DCOx = 0, MODx = 0	0.32	0.75	MHz
$f_{DCO(2,31)}$	DCO frequency (2, 31) <sup>(1)</sup>	DCORSELx = 2, DCOx = 31, MODx = 0	3.17	7.38	MHz
$f_{DCO(3,0)}$	DCO frequency (3, 0) <sup>(1)</sup>	DCORSELx = 3, DCOx = 0, MODx = 0	0.64	1.51	MHz
$f_{DCO(3,31)}$	DCO frequency (3, 31) <sup>(1)</sup>	DCORSELx = 3, DCOx = 31, MODx = 0	6.07	14.0	MHz
$f_{DCO(4,0)}$	DCO frequency (4, 0) <sup>(1)</sup>	DCORSELx = 4, DCOx = 0, MODx = 0	1.3	3.2	MHz
$f_{DCO(4,31)}$	DCO frequency (4, 31) <sup>(1)</sup>	DCORSELx = 4, DCOx = 31, MODx = 0	12.3	28.2	MHz
$f_{DCO(5,0)}$	DCO frequency (5, 0) <sup>(1)</sup>	DCORSELx = 5, DCOx = 0, MODx = 0	2.5	6.0	MHz
$f_{DCO(5,31)}$	DCO frequency (5, 31) <sup>(1)</sup>	DCORSELx = 5, DCOx = 31, MODx = 0	23.7	54.1	MHz
$f_{DCO(6,0)}$	DCO frequency (6, 0) <sup>(1)</sup>	DCORSELx = 6, DCOx = 0, MODx = 0	4.6	10.7	MHz
$f_{DCO(6,31)}$	DCO frequency (6, 31) <sup>(1)</sup>	DCORSELx = 6, DCOx = 31, MODx = 0	39.0	88.0	MHz
$f_{DCO(7,0)}$	DCO frequency (7, 0) <sup>(1)</sup>	DCORSELx = 7, DCOx = 0, MODx = 0	8.5	19.6	MHz
$f_{DCO(7,31)}$	DCO frequency (7, 31) <sup>(1)</sup>	DCORSELx = 7, DCOx = 31, MODx = 0	60	135	MHz
$S_{DCORSEL}$	Frequency step between range DCORSEL and DCORSEL + 1	$S_{RSEL} = f_{DCO(DCORSEL+1,DCO)} / f_{DCO(DCORSEL,DCO)}$	1.2	2.3	ratio
$S_{DCO}$	Frequency step between tap DCO and DCO + 1	$S_{DCO} = f_{DCO(DCORSEL,DCO+1)} / f_{DCO(DCORSEL,DCO)}$	1.02	1.12	ratio
	Duty cycle	Measured at SMCLK	40%	50%	60%
$df_{DCO}/dT$	DCO frequency temperature drift <sup>(2)</sup>	$f_{DCO} = 1$ MHz		0.1	%/°C
$df_{DCO}/dV_{CC}$	DCO frequency voltage drift <sup>(3)</sup>	$f_{DCO} = 1$ MHz		1.9	%/V

- (1) When selecting the proper DCO frequency range (DCORSELx), the target DCO frequency,  $f_{DCO}$ , should be set to reside within the range of  $f_{DCO(n,0),MAX} \leq f_{DCO} \leq f_{DCO(n,31),MIN}$ , where  $f_{DCO(n,0),MAX}$  represents the maximum frequency specified for the DCO frequency, range n, tap 0 (DCOx = 0) and  $f_{DCO(n,31),MIN}$  represents the minimum frequency specified for the DCO frequency, range n, tap 31 (DCOx = 31). This ensures that the target DCO frequency resides within the range selected. It should also be noted that if the actual  $f_{DCO}$  frequency for the selected range causes the FLL or the application to select tap 0 or 31, the DCO fault flag is set to report that the selected range is at its minimum or maximum tap setting.
- (2) Calculated using the box method:  $(MAX(-40^{\circ}C \text{ to } 85^{\circ}C) - MIN(-40^{\circ}C \text{ to } 85^{\circ}C)) / MIN(-40^{\circ}C \text{ to } 85^{\circ}C) / (85^{\circ}C - (-40^{\circ}C))$
- (3) Calculated using the box method:  $(MAX(1.8 \text{ V to } 3.6 \text{ V}) - MIN(1.8 \text{ V to } 3.6 \text{ V})) / MIN(1.8 \text{ V to } 3.6 \text{ V}) / (3.6 \text{ V} - 1.8 \text{ V})$

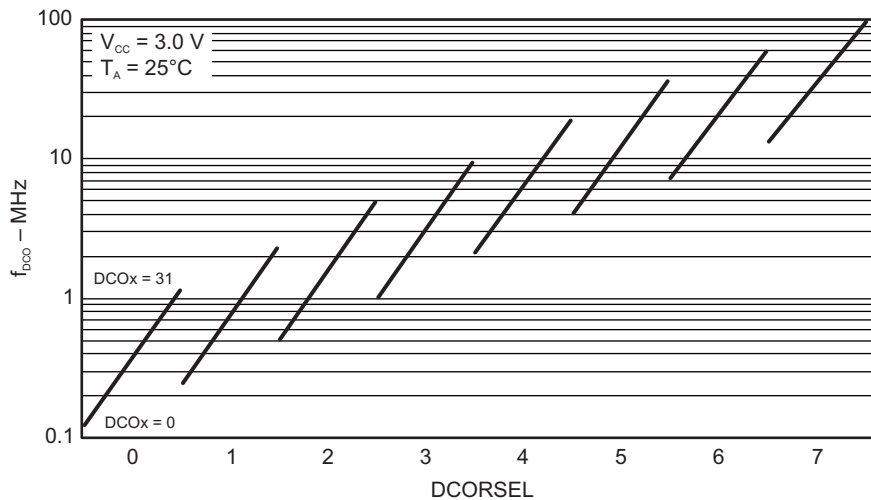

Figure 5-12. Typical DCO Frequency

## 5.26 PMM, Brownout Reset (BOR)

over recommended ranges of supply voltage and operating free-air temperature (unless otherwise noted)

PARAMETER		TEST CONDITIONS	MIN	TYP	MAX	UNIT
V <sub>DVCC_BOR_IT-</sub>	BOR <sub>H</sub> on voltage, DV <sub>CC</sub> falling level	dDV <sub>CC</sub> /dt  < 3 V/s			1.45	V
V <sub>DVCC_BOR_IT+</sub>	BOR <sub>H</sub> off voltage, DV <sub>CC</sub> rising level	dDV <sub>CC</sub> /dt  < 3 V/s	0.80	1.30	1.50	V
V <sub>DVCC_BOR_hys</sub>	BOR <sub>H</sub> hysteresis		50		250	mV
t <sub>RESET</sub>	Pulse duration required at RST/NMI pin to accept a reset		2			μs

## 5.27 PMM, Core Voltage

over recommended ranges of supply voltage and operating free-air temperature (unless otherwise noted)

PARAMETER		TEST CONDITIONS	MIN	TYP	MAX	UNIT
V <sub>CORE3(AM)</sub>	Core voltage, active mode, PMMCOREV = 3	2.4 V ≤ DV <sub>CC</sub> ≤ 3.6 V		1.90		V
V <sub>CORE2(AM)</sub>	Core voltage, active mode, PMMCOREV = 2	2.2 V ≤ DV <sub>CC</sub> ≤ 3.6 V		1.80		V
V <sub>CORE1(AM)</sub>	Core voltage, active mode, PMMCOREV = 1	2.0 V ≤ DV <sub>CC</sub> ≤ 3.6 V		1.60		V
V <sub>CORE0(AM)</sub>	Core voltage, active mode, PMMCOREV = 0	1.8 V ≤ DV <sub>CC</sub> ≤ 3.6 V		1.40		V
V <sub>CORE3(LPM)</sub>	Core voltage, low-current mode, PMMCOREV = 3	2.4 V ≤ DV <sub>CC</sub> ≤ 3.6 V		1.94		V
V <sub>CORE2(LPM)</sub>	Core voltage, low-current mode, PMMCOREV = 2	2.2 V ≤ DV <sub>CC</sub> ≤ 3.6 V		1.84		V
V <sub>CORE1(LPM)</sub>	Core voltage, low-current mode, PMMCOREV = 1	2.0 V ≤ DV <sub>CC</sub> ≤ 3.6 V		1.64		V
V <sub>CORE0(LPM)</sub>	Core voltage, low-current mode, PMMCOREV = 0	1.8 V ≤ DV <sub>CC</sub> ≤ 3.6 V		1.44		V

## 5.28 PMM, SVS High Side

over recommended ranges of supply voltage and operating free-air temperature (unless otherwise noted)

PARAMETER		TEST CONDITIONS	MIN	TYP	MAX	UNIT
$I_{(SVSH)}$	SVS current consumption	SVSHE = 0, DV <sub>CC</sub> = 3.6 V		0		nA
		SVSHE = 1, DV <sub>CC</sub> = 3.6 V, SVSHFP = 0		200		
		SVSHE = 1, DV <sub>CC</sub> = 3.6 V, SVSHFP = 1		1.5		μA
$V_{(SVSH\_IT-)}$	SVS <sub>H</sub> on voltage level <sup>(1)</sup>	SVSHE = 1, SVSHRVL = 0	1.57	1.68	1.78	V
		SVSHE = 1, SVSHRVL = 1	1.79	1.88	1.98	
		SVSHE = 1, SVSHRVL = 2	1.98	2.08	2.21	
		SVSHE = 1, SVSHRVL = 3	2.10	2.18	2.31	
$V_{(SVSH\_IT+)}$	SVS <sub>H</sub> off voltage level <sup>(1)</sup>	SVSHE = 1, SVSMHRRRL = 0	1.62	1.74	1.85	V
		SVSHE = 1, SVSMHRRRL = 1	1.88	1.94	2.07	
		SVSHE = 1, SVSMHRRRL = 2	2.07	2.14	2.28	
		SVSHE = 1, SVSMHRRRL = 3	2.20	2.30	2.42	
		SVSHE = 1, SVSMHRRRL = 4	2.32	2.40	2.55	
		SVSHE = 1, SVSMHRRRL = 5	2.52	2.70	2.88	
		SVSHE = 1, SVSMHRRRL = 6	2.90	3.10	3.23	
		SVSHE = 1, SVSMHRRRL = 7	2.90	3.10	3.23	
$t_{pd(SVSH)}$	SVS <sub>H</sub> propagation delay	SVSHE = 1, dV <sub>DVCC</sub> /dt = 10 mV/μs, SVSHFP = 1		2.5		μs
		SVSHE = 1, dV <sub>DVCC</sub> /dt = 1 mV/μs, SVSHFP = 0		20		
$t_{(SVSH)}$	SVS <sub>H</sub> on or off delay time	SVSHE = 0 → 1, dV <sub>DVCC</sub> /dt = 10 mV/μs, SVSHFP = 1		12.5		μs
		SVSHE = 0 → 1, dV <sub>DVCC</sub> /dt = 1 mV/μs, SVSHFP = 0		100		
dV <sub>DVCC</sub> /dt	DV <sub>CC</sub> rise time		0		1000	V/s

(1) The SVS<sub>H</sub> settings available depend on the V<sub>CORE</sub> (PMMCOREV<sub>x</sub>) setting. See the *Power Management Module and Supply Voltage Supervisor* chapter in the [MSP430F5xx and MSP430F6xx Family User's Guide](#) on recommended settings and use.

## 5.29 PMM, SVM High Side

over recommended ranges of supply voltage and operating free-air temperature (unless otherwise noted)

PARAMETER		TEST CONDITIONS	MIN	TYP	MAX	UNIT
$I_{(SVMH)}$	SVM <sub>H</sub> current consumption	SVMHE = 0, DV <sub>CC</sub> = 3.6 V		0		nA
		SVMHE = 1, DV <sub>CC</sub> = 3.6 V, SVMHFP = 0		200		
		SVMHE = 1, DV <sub>CC</sub> = 3.6 V, SVMHFP = 1			1.5	
$V_{(SVMH)}$	SVM <sub>H</sub> on or off voltage level <sup>(1)</sup>	SVMHE = 1, SVSMHRRRL = 0	1.62	1.74	1.85	V
		SVMHE = 1, SVSMHRRRL = 1	1.88	1.94	2.07	
		SVMHE = 1, SVSMHRRRL = 2	2.07	2.14	2.28	
		SVMHE = 1, SVSMHRRRL = 3	2.20	2.30	2.42	
		SVMHE = 1, SVSMHRRRL = 4	2.32	2.40	2.55	
		SVMHE = 1, SVSMHRRRL = 5	2.52	2.70	2.88	
		SVMHE = 1, SVSMHRRRL = 6	2.90	3.10	3.23	
		SVMHE = 1, SVSMHRRRL = 7	2.90	3.10	3.23	
$t_{pd(SVMH)}$	SVM <sub>H</sub> propagation delay	SVMHE = 1, dV <sub>DVCC</sub> /dt = 10 mV/μs, SVMHFP = 1		2.5		μs
		SVMHE = 1, dV <sub>DVCC</sub> /dt = 1 mV/μs, SVMHFP = 0		20		
$t_{(SVMH)}$	SVM <sub>H</sub> on or off delay time	SVMHE = 0 → 1, dV <sub>DVCC</sub> /dt = 10 mV/μs, SVMHFP = 1		12.5		μs
		SVMHE = 0 → 1, dV <sub>DVCC</sub> /dt = 1 mV/μs, SVMHFP = 0		100		

(1) The SVM<sub>H</sub> settings available depend on the V<sub>CORE</sub> (PMMCOREV<sub>x</sub>) setting. See the *Power Management Module and Supply Voltage Supervisor* chapter in the [MSP430F5xx and MSP430F6xx Family User's Guide](#) on recommended settings and use.

## 5.30 PMM, SVS Low Side

over recommended ranges of supply voltage and operating free-air temperature (unless otherwise noted)

PARAMETER		TEST CONDITIONS	MIN	TYP	MAX	UNIT
$I_{(SVSL)}$	SVS <sub>L</sub> current consumption	SVSLE = 0, PMMCOREV = 2		0		nA
		SVSLE = 1, PMMCOREV = 2, SVSLFP = 0		200		
		SVSLE = 1, PMMCOREV = 2, SVSLFP = 1			1.5	
$t_{pd(SVSL)}$	SVS <sub>L</sub> propagation delay	SVSLE = 1, dV <sub>CORE</sub> /dt = 10 mV/μs, SVSLFP = 1		2.5		μs
		SVSLE = 1, dV <sub>CORE</sub> /dt = 1 mV/μs, SVSLFP = 0		20		
$t_{(SVSL)}$	SVS <sub>L</sub> on or off delay time	SVSLE = 0 → 1, dV <sub>CORE</sub> /dt = 10 mV/μs, SVSLFP = 1		12.5		μs
		SVSLE = 0 → 1, dV <sub>CORE</sub> /dt = 1 mV/μs, SVSLFP = 0		100		

### 5.31 PMM, SVM Low Side

over recommended ranges of supply voltage and operating free-air temperature (unless otherwise noted)

PARAMETER		TEST CONDITIONS	MIN	TYP	MAX	UNIT
$I_{(SVML)}$	SVM <sub>L</sub> current consumption	SVMLE = 0, PMMCOREV = 2		0		nA
		SVMLE = 1, PMMCOREV = 2, SVMLFP = 0		200		
		SVMLE = 1, PMMCOREV = 2, SVMLFP = 1		1.5		μA
$t_{pd(SVML)}$	SVM <sub>L</sub> propagation delay	SVMLE = 1, $dV_{CORE}/dt = 10 \text{ mV}/\mu\text{s}$ , SVMLFP = 1		2.5		μs
		SVMLE = 1, $dV_{CORE}/dt = 1 \text{ mV}/\mu\text{s}$ , SVMLFP = 0		20		
$t_{(SVML)}$	SVM <sub>L</sub> on or off delay time	SVMLE = 0 → 1, $dV_{CORE}/dt = 10 \text{ mV}/\mu\text{s}$ , SVMLFP = 1		12.5		μs
		SVMLE = 0 → 1, $dV_{CORE}/dt = 1 \text{ mV}/\mu\text{s}$ , SVMLFP = 0		100		

### 5.32 Wake-up Times From Low-Power Modes and Reset

over recommended ranges of supply voltage and operating free-air temperature (unless otherwise noted)

PARAMETER		TEST CONDITIONS	MIN	TYP	MAX	UNIT	
$t_{\text{WAKE-UP-FAST}}$	Wake-up time from LPM2, LPM3, or LPM4 to active mode <sup>(1)</sup>	PMMCOREV = SVSMLRRL = n (where n = 0, 1, 2, or 3), SVSLFP = 1		$f_{\text{MCLK}} \geq 4.0 \text{ MHz}$	3.5	7.5	μs
		$1.0 \text{ MHz} < f_{\text{MCLK}} < 4.0 \text{ MHz}$		4.5	9		
$t_{\text{WAKE-UP-SLOW}}$	Wake-up time from LPM2, LPM3, or LPM4 to active mode <sup>(2)(3)</sup>	PMMCOREV = SVSMLRRL = n (where n = 0, 1, 2, or 3), SVSLFP = 0		150	175	μs	
$t_{\text{WAKE-UP-LPM5}}$	Wake-up time from LPM4.5 to active mode <sup>(4)</sup>			2	3	ms	
$t_{\text{WAKE-UP-RESET}}$	Wake-up time from $\overline{\text{RST}}$ or BOR event to active mode <sup>(4)</sup>			2	3	ms	

- (1) This value represents the time from the wake-up event to the first active edge of MCLK. The wake-up time depends on the performance mode of the low-side supervisor (SVS<sub>L</sub>) and low-side monitor (SVM<sub>L</sub>).  $t_{\text{WAKE-UP-FAST}}$  is possible with SVS<sub>L</sub> and SVM<sub>L</sub> in full performance mode or disabled. For specific register settings, see the *Low-Side SVS and SVM Control and Performance Mode Selection* section in the *Power Management Module and Supply Voltage Supervisor* chapter of the [MSP430F5xx and MSP430F6xx Family User's Guide](#).
- (2) This value represents the time from the wake-up event to the first active edge of MCLK. The wake-up time depends on the performance mode of the low-side supervisor (SVS<sub>L</sub>) and low-side monitor (SVM<sub>L</sub>).  $t_{\text{WAKE-UP-SLOW}}$  is set with SVS<sub>L</sub> and SVM<sub>L</sub> in normal mode (low current mode). For specific register settings, see the *Low-Side SVS and SVM Control and Performance Mode Selection* section in the *Power Management Module and Supply Voltage Supervisor* chapter of the [MSP430F5xx and MSP430F6xx Family User's Guide](#).
- (3) The wake-up times from LPM0 and LPM1 to AM are not specified. They are proportional to MCLK cycle time but are not affected by the performance mode settings as for LPM2, LPM3, and LPM4.
- (4) This value represents the time from the wake-up event to the reset vector execution.

### 5.33 Timer\_A

over recommended ranges of supply voltage and operating free-air temperature (unless otherwise noted)

PARAMETER		TEST CONDITIONS	V <sub>CC</sub>	V <sub>IO</sub>	MIN	TYP	MAX	UNIT
f <sub>TA</sub>	Timer_A input clock frequency	Internal: SMCLK or ACLK, External: TACLK, Duty cycle = 50% ±10%	1.8 V	1.62 V to 1.8 V			25	MHz
			3.0 V	1.62 V to 1.98 V			25	
t <sub>TA,cap</sub>	Timer_A capture timing <sup>(1)</sup>	All capture inputs, Minimum pulse duration required for capture	1.8 V	1.62 V to 1.8 V	20			ns
			3.0 V	1.62 V to 1.98 V	20			

(1) The external signal sets the interrupt flag every time the minimum parameters are met. It may be set even with trigger signals shorter than t<sub>TA,cap</sub>.

### 5.34 Timer\_B

over recommended ranges of supply voltage and operating free-air temperature (unless otherwise noted)

PARAMETER		TEST CONDITIONS	V <sub>CC</sub>	V <sub>IO</sub>	MIN	TYP	MAX	UNIT
f <sub>TB</sub>	Timer_B input clock frequency	Internal: SMCLK or ACLK, External: TBCLK, Duty cycle = 50% ±10%	1.8 V	1.62 V to 1.8 V			25	MHz
			3.0 V	1.62 V to 1.98 V			25	
t <sub>TB,cap</sub>	Timer_B capture timing <sup>(1)</sup>	All capture inputs, Minimum pulse duration required for capture	1.8 V	1.62 V to 1.8 V	20			ns
			3.0 V	1.62 V to 1.98 V	20			

(1) The external signal sets the interrupt flag every time the minimum parameters are met. It may be set even with trigger signals shorter than t<sub>TB,cap</sub>.

### 5.35 USCI (UART Mode), Recommended Operating Conditions

PARAMETER		TEST CONDITIONS	MIN	MAX	UNIT
f <sub>USCI</sub>	USCI input clock frequency	Internal: SMCLK or ACLK, External: UCLK, Duty cycle = 50% ±10%		f <sub>SYSTEM</sub>	MHz
f <sub>BITCLK</sub>	BITCLK clock frequency (equals baud rate in MBaud)			1	MHz

### 5.36 USCI (UART Mode)

over recommended ranges of supply voltage and operating free-air temperature (unless otherwise noted)

PARAMETER		V <sub>CC</sub>	V <sub>IO</sub>	MIN	MAX	UNIT
t <sub>r</sub>	UART receive deglitch time <sup>(1)</sup>	1.8 V	1.62 V to 1.80 V	50	600	ns
		3.0 V	1.62 V to 1.98 V	50	600	

(1) Pulses on the UART receive input (UCxRX) shorter than the UART receive deglitch time are suppressed. To ensure that pulses are correctly recognized, their duration should exceed the maximum specification of the deglitch time.

### 5.37 USCI (SPI Master Mode), Recommended Operating Conditions

PARAMETER		TEST CONDITIONS	MIN	MAX	UNIT
f <sub>USCI</sub>	USCI input clock frequency	Internal: SMCLK or ACLK, Duty cycle = 50% ±10%		f <sub>SYSTEM</sub>	MHz

### 5.38 USCI (SPI Master Mode)

over recommended ranges of supply voltage and operating free-air temperature (unless otherwise noted)<sup>(1)</sup>  
(see [Figure 5-13](#) and [Figure 5-14](#))

PARAMETER		TEST CONDITIONS	V <sub>CC</sub>	V <sub>IO</sub>	MIN	MAX	UNIT
f <sub>USCI</sub>	USCI input clock frequency	SMCLK or ACLK, Duty cycle = 50% ±10%				f <sub>SYSTEM</sub>	MHz
t <sub>SU,MI</sub>	SOMI input data setup time	PMMCOREV = 0	1.8 V	1.62 V to 1.80 V	55		ns
			3.0 V	1.62 V to 1.98 V	55		
		PMMCOREV = 3	2.4 V	1.62 V to 1.98 V	35		
			3.0 V	1.62 V to 1.98 V	35		
t <sub>HD,MI</sub>	SOMI input data hold time	PMMCOREV = 0	1.8 V	1.62 V to 1.80 V	0		ns
			3.0 V	1.62 V to 1.98 V	0		
		PMMCOREV = 3	2.4 V	1.62 V to 1.98 V	0		
			3.0 V	1.62 V to 1.98 V	0		
t <sub>VALID,MO</sub>	SIMO output data valid time <sup>(2)</sup>	UCLK edge to SIMO valid, C <sub>L</sub> = 20 pF, PMMCOREV = 0	1.8 V	1.62 V to 1.80 V		20	ns
			3.0 V	1.62 V to 1.98 V		20	
		UCLK edge to SIMO valid, C <sub>L</sub> = 20 pF, PMMCOREV = 3	2.4 V	1.62 V to 1.98 V		16	
			3.0 V	1.62 V to 1.98 V		16	
t <sub>HD,MO</sub>	SIMO output data hold time <sup>(3)</sup>	C <sub>L</sub> = 20 pF, PMMCOREV = 0	1.8 V	1.62 V to 1.80 V	-10		ns
			3.0 V	1.62 V to 1.98 V	-10		
		C <sub>L</sub> = 20 pF, PMMCOREV = 3	2.4 V	1.62 V to 1.98 V	-10		
			3.0 V	1.62 V to 1.98 V	-10		

- (1)  $f_{UCxCLK} = 1/2t_{LO/HI}$  with  $t_{LO/HI} \geq \max(t_{VALID,MO}(USCI) + t_{SU,SI}(Slave), t_{SU,MI}(USCI) + t_{VALID,SO}(Slave))$   
For the slave parameters  $t_{SU,SI}(Slave)$  and  $t_{VALID,SO}(Slave)$ , see the SPI parameters of the attached slave.
- (2) Specifies the time to drive the next valid data to the SIMO output after the output changing UCLK clock edge. See the timing diagrams in [Figure 5-13](#) and [Figure 5-14](#).
- (3) Specifies how long data on the SIMO output is valid after the output changing UCLK clock edge. Negative values indicate that the data on the SIMO output can become invalid before the output changing clock edge observed on UCLK. See the timing diagrams in [Figure 5-13](#) and [Figure 5-14](#).

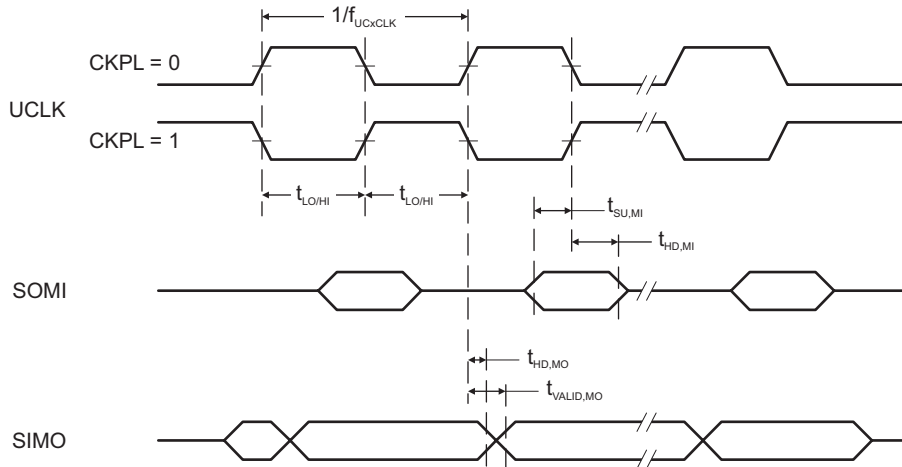

Figure 5-13. SPI Master Mode, CKPH = 0

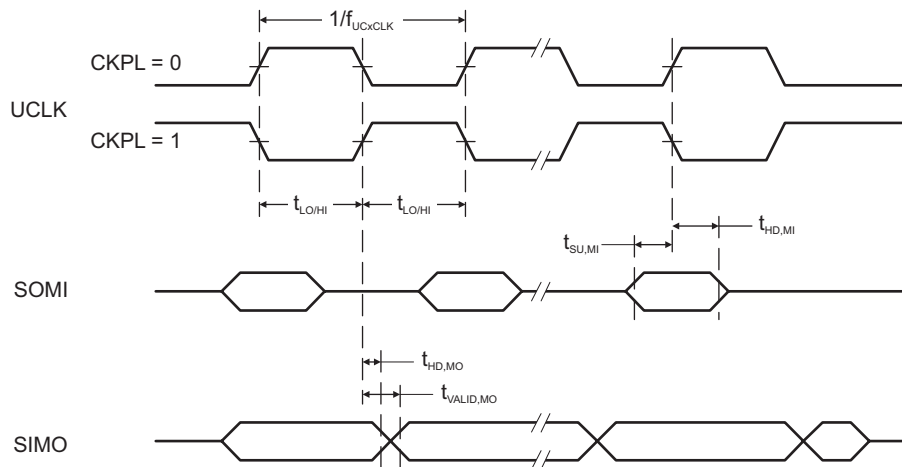

Figure 5-14. SPI Master Mode, CKPH = 1

### 5.39 USCI (SPI Slave Mode)

over recommended ranges of supply voltage and operating free-air temperature (unless otherwise noted)<sup>(1)</sup>  
(see [Figure 5-15](#) and [Figure 5-16](#))

PARAMETER	TEST CONDITIONS	V <sub>CC</sub>	V <sub>IO</sub>	MIN	MAX	UNIT
t <sub>STE,LEAD</sub> STE lead time, STE low to clock	PMMCOREV = 0	1.8 V	1.62 V to 1.80 V	12		ns
		3.0 V	1.62 V to 1.98 V	12		
	PMMCOREV = 3	2.4 V	1.62 V to 1.98 V	10		
		3.0 V	1.62 V to 1.98 V	10		
t <sub>STE,LAG</sub> STE lag time, Last clock to STE high	PMMCOREV = 0	1.8 V	1.62 V to 1.80 V	6		ns
		3.0 V	1.62 V to 1.98 V	6		
	PMMCOREV = 3	2.4 V	1.62 V to 1.98 V	6		
		3.0 V	1.62 V to 1.98 V	6		
t <sub>STE,ACC</sub> STE access time, STE low to SOMI data out	PMMCOREV = 0	1.8 V	1.62 V to 1.80 V		65	ns
		3.0 V	1.62 V to 1.98 V		65	
	PMMCOREV = 3	2.4 V	1.62 V to 1.98 V		45	
		3.0 V	1.62 V to 1.98 V		45	
t <sub>STE,DIS</sub> STE disable time, STE high to SOMI high impedance	PMMCOREV = 0	1.8 V	1.62 V to 1.80 V		35	ns
		3.0 V	1.62 V to 1.98 V		35	
	PMMCOREV = 3	2.4 V	1.62 V to 1.98 V		25	
		3.0 V	1.62 V to 1.98 V		25	
t <sub>SU,SI</sub> SIMO input data setup time	PMMCOREV = 0	1.8 V	1.62 V to 1.80 V	5		ns
		3.0 V	1.62 V to 1.98 V	5		
	PMMCOREV = 3	2.4 V	1.62 V to 1.98 V	5		
		3.0 V	1.62 V to 1.98 V	5		
t <sub>HD,SI</sub> SIMO input data hold time	PMMCOREV = 0	1.8 V	1.62 V to 1.80 V	5		ns
		3.0 V	1.62 V to 1.98 V	5		
	PMMCOREV = 3	2.4 V	1.62 V to 1.98 V	5		
		3.0 V	1.62 V to 1.98 V	5		
t <sub>VALID,SO</sub> SOMI output data valid time <sup>(2)</sup>	UCLK edge to SOMI valid, C <sub>L</sub> = 20 pF, PMMCOREV = 0	1.8 V	1.62 V to 1.80 V		75	ns
		3.0 V	1.62 V to 1.98 V		75	
	UCLK edge to SOMI valid, C <sub>L</sub> = 20 pF, PMMCOREV = 3	2.4 V	1.62 V to 1.98 V		50	
		3.0 V	1.62 V to 1.98 V		50	
t <sub>HD,SO</sub> SOMI output data hold time <sup>(3)</sup>	C <sub>L</sub> = 20 pF, PMMCOREV = 0	1.8 V	1.62 V to 1.80 V	18		ns
		3.0 V	1.62 V to 1.98 V	18		
	C <sub>L</sub> = 20 pF, PMMCOREV = 3	2.4 V	1.62 V to 1.98 V	10		
		3.0 V	1.62 V to 1.98 V	10		

- (1)  $f_{UCxCLK} = 1/2t_{LO/HI}$  with  $t_{LO/HI} \geq \max(t_{VALID,MO(Master)} + t_{SU,SI(USCI)}, t_{SU,MI(Master)} + t_{VALID,SO(USCI)})$   
For the master parameters  $t_{SU,MI(Master)}$  and  $t_{VALID,MO(Master)}$ , see the SPI parameters of the attached master.
- (2) Specifies the time to drive the next valid data to the SOMI output after the output changing UCLK clock edge. See the timing diagrams in [Figure 5-15](#) and [Figure 5-16](#).
- (3) Specifies how long data on the SOMI output is valid after the output changing UCLK clock edge. See the timing diagrams in [Figure 5-15](#) and [Figure 5-16](#).

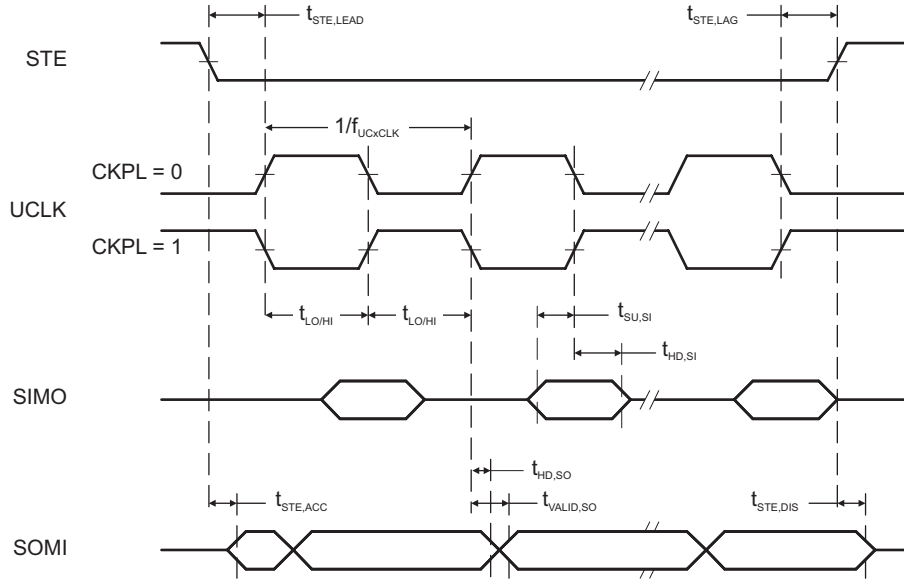

Figure 5-15. SPI Slave Mode, CKPH = 0

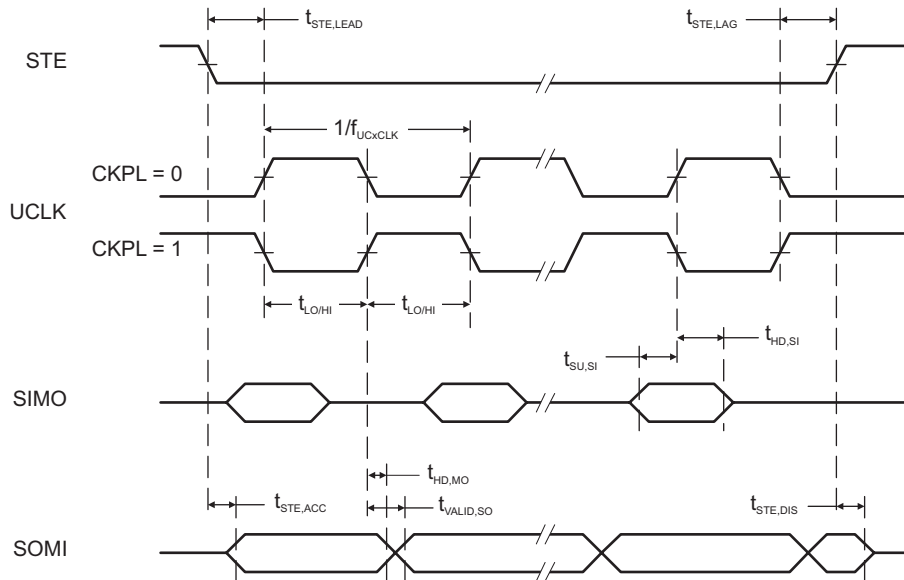

Figure 5-16. SPI Slave Mode, CKPH = 1

## 5.40 USCI (I<sup>2</sup>C Mode)

over recommended ranges of supply voltage and operating free-air temperature (unless otherwise noted) (see [Figure 5-17](#))

PARAMETER	TEST CONDITIONS	V <sub>CC</sub>	V <sub>IO</sub> <sup>(1)</sup>	MIN	MAX	UNIT	
f <sub>USCI</sub>	USCI input clock frequency			f <sub>SYSTEM</sub>		MHz	
f <sub>SCL</sub>	SCL clock frequency	2.2 V, 3 V	1.62 V to 1.98 V	0	400	kHz	
t <sub>HD,STA</sub>	Hold time (repeated) START	f <sub>SCL</sub> ≤ 100 kHz f <sub>SCL</sub> > 100 kHz	2.2 V, 3 V	1.62 V to 1.98 V	4.0	μs	
	0.6						
t <sub>SU,STA</sub>	Setup time for a repeated START	f <sub>SCL</sub> ≤ 100 kHz f <sub>SCL</sub> > 100 kHz	2.2 V, 3 V	1.62 V to 1.98 V	4.7	μs	
	0.6						
t <sub>HD,DAT</sub>	Data hold time		2.2 V, 3 V	1.62 V to 1.98 V	0	ns	
t <sub>SU,DAT</sub>	Data setup time		2.2 V, 3 V	1.62 V to 1.98 V	250	ns	
t <sub>SU,STO</sub>	Setup time for STOP	f <sub>SCL</sub> ≤ 100 kHz f <sub>SCL</sub> > 100 kHz	2.2 V, 3 V	1.62 V to 1.98 V	4.0	μs	
	0.6						
t <sub>SP</sub>	Pulse duration of spikes suppressed by input filter		2.2 V, 3 V	1.62 V to 1.98 V	50	600	ns

(1) In all test conditions, V<sub>IO</sub> ≤ V<sub>CC</sub>

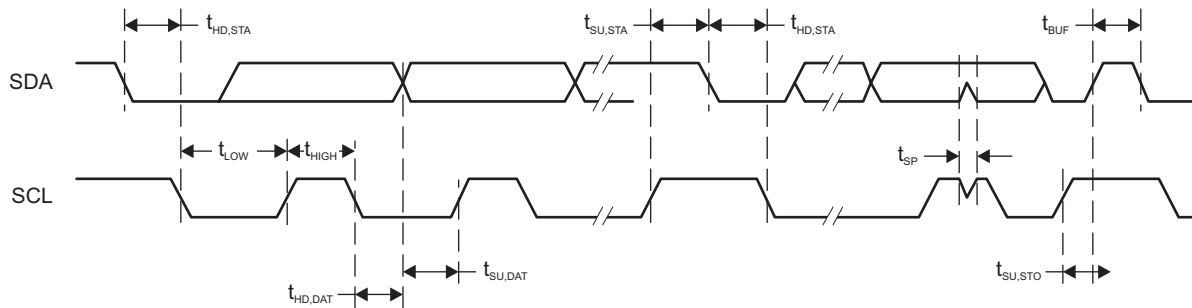

Figure 5-17. I<sup>2</sup>C Mode Timing

## 5.41 10-Bit ADC, Power Supply and Input Range Conditions

over recommended ranges of supply voltage and operating free-air temperature (unless otherwise noted)<sup>(1)</sup>

PARAMETER		TEST CONDITIONS	V <sub>CC</sub>	MIN	TYP	MAX	UNIT
AV <sub>CC</sub>	Analog supply voltage	AV <sub>CC</sub> and DV <sub>CC</sub> are connected together, AV <sub>SS</sub> and DV <sub>SS</sub> are connected together, V <sub>(AVSS)</sub> = V <sub>(DVSS)</sub> = 0 V		1.8		3.6	V
V <sub>(Ax)</sub>	Analog input voltage range <sup>(2)</sup>	All ADC10_A pins: P1.0 to P1.5 and P3.6 and P3.7 terminals		0		AV <sub>CC</sub>	V
I <sub>ADC10_A</sub>	Operating supply current into AVCC terminal, REF module and reference buffer off	f <sub>ADC10CLK</sub> = 5.0 MHz, ADC10ON = 1, REFON = 0, SHT0 = 0, SHT1 = 0, ADC10DIV = 0, ADC10SREF = 00	2.2 V		60	100	μA
			3 V		75	110	
	Operating supply current into AVCC terminal, REF module on, reference buffer on	f <sub>ADC10CLK</sub> = 5.0 MHz, ADC10ON = 1, REFON = 1, SHT0 = 0, SHT1 = 0, ADC10DIV = 0, ADC10SREF = 01	3 V		113	150	
	Operating supply current into AVCC terminal, REF module off, reference buffer on	f <sub>ADC10CLK</sub> = 5.0 MHz, ADC10ON = 1, REFON = 0, SHT0 = 0, SHT1 = 0, ADC10DIV = 0, ADC10SREF = 10, VREF = 2.5 V	3 V		105	140	
	Operating supply current into AVCC terminal, REF module off, reference buffer off	f <sub>ADC10CLK</sub> = 5.0 MHz, ADC10ON = 1, REFON = 0, SHT0 = 0, SHT1 = 0, ADC10DIV = 0, ADC10SREF = 11, VREF = 2.5 V	3 V		70	110	
C <sub>I</sub>	Input capacitance	Only one terminal Ax can be selected at one time from the pad to the ADC10_A capacitor array including wiring and pad.	2.2 V		3.5		pF
R <sub>I</sub>	Input MUX ON resistance	AV <sub>CC</sub> > 2 V, 0 V ≤ V <sub>Ax</sub> ≤ AV <sub>CC</sub>				36	kΩ
		1.8 V < AV <sub>CC</sub> < 2 V, 0 V ≤ V <sub>Ax</sub> ≤ AV <sub>CC</sub>				96	

(1) The leakage current is defined in the leakage current table with P6.x/Ax parameter.

(2) The analog input voltage range must be within the selected reference voltage range V<sub>R+</sub> to V<sub>R-</sub> for valid conversion results. The external reference voltage requires decoupling capacitors. See 0.

## 5.42 10-Bit ADC, Timing Parameters

over recommended ranges of supply voltage and operating free-air temperature (unless otherwise noted)

PARAMETER		TEST CONDITIONS	V <sub>CC</sub>	MIN	TYP	MAX	UNIT
f <sub>ADC10CLK</sub>	Input clock frequency	For specified performance of ADC10_A linearity parameters	2.2 V, 3 V	0.45	5	5.5	MHz
f <sub>ADC10OSC</sub>	Internal ADC10_A oscillator <sup>(1)</sup>	ADC10DIV = 0, f <sub>ADC10CLK</sub> = f <sub>ADC10OSC</sub>	2.2 V, 3 V	4.2	4.8	5.4	MHz
t <sub>CONVERT</sub>	Conversion time	REFON = 0, Internal oscillator, 12 ADC10CLK cycles, 10-bit mode, f <sub>ADC10OSC</sub> = 4 MHz to 5 MHz	2.2 V, 3 V	2.4		3.0	μs
		External f <sub>ADC10CLK</sub> from ACLK, MCLK or SMCLK, ADC10SSEL ≠ 0			12 × 1 / f <sub>ADC10CLK</sub>		
t <sub>ADC10ON</sub>	Turn on settling time of the ADC	See (2)				100	ns
t <sub>Sample</sub>	Sampling time	R <sub>S</sub> = 1000 Ω, R <sub>I</sub> = 96 k Ω, C <sub>I</sub> = 3.5 pF <sup>(3)</sup>	1.8 V	3			μs
			3.0 V	1			μs

(1) The ADC10OSC is sourced directly from MODOSC inside the UCS.

(2) The condition is that the error in a conversion started after t<sub>ADC10ON</sub> is less than ±0.5 LSB. The reference and input signal are already settled.

(3) Approximately 8 Tau (τ) are needed to get an error of less than ±0.5 LSB

### 5.43 10-Bit ADC, Linearity Parameters

over recommended ranges of supply voltage and operating free-air temperature (unless otherwise noted)

PARAMETER		TEST CONDITIONS	V <sub>CC</sub>	MIN	TYP	MAX	UNIT
E <sub>I</sub>	Integral linearity error	1.4 V ≤ (V <sub>eREF+</sub> – V <sub>eREF-</sub> ) ≤ 1.6 V, C <sub>VeREF+</sub> = 20 pF	2.2 V, 3 V			±1.0	LSB
		1.6 V < (V <sub>eREF+</sub> – V <sub>eREF-</sub> ) ≤ V <sub>AVCC</sub> , C <sub>VeREF+</sub> = 20 pF				±1.0	
E <sub>D</sub>	Differential linearity error	1.4 V ≤ (V <sub>eREF+</sub> – V <sub>eREF-</sub> ), C <sub>VeREF+</sub> = 20 pF	2.2 V, 3 V			±1.0	LSB
E <sub>O</sub>	Offset error	1.4 V ≤ (V <sub>eREF+</sub> – V <sub>eREF-</sub> ), C <sub>VeREF+</sub> = 20 pF Internal impedance of source R <sub>S</sub> < 100 Ω	2.2 V, 3 V			±1.0	LSB
E <sub>G</sub>	Gain error	1.4 V ≤ (V <sub>eREF+</sub> – V <sub>eREF-</sub> ), C <sub>VeREF+</sub> = 20 pF, ADC10SREFX = 11b	2.2 V, 3 V			±1.0	LSB
E <sub>T</sub>	Total unadjusted error	1.4 V ≤ (V <sub>eREF+</sub> – V <sub>eREF-</sub> ), C <sub>VeREF+</sub> = 20 pF, ADC10SREFX = 11b	2.2 V, 3 V		±1.0	±2.0	LSB

### 5.44 REF, External Reference

over recommended ranges of supply voltage and operating free-air temperature (unless otherwise noted)<sup>(1)</sup>

PARAMETER		TEST CONDITIONS	V <sub>CC</sub>	MIN	MAX	UNIT
V <sub>eREF+</sub>	Positive external reference voltage input	V <sub>eREF+</sub> > V <sub>eREF-</sub> <sup>(2)</sup>		1.4	AV <sub>CC</sub>	V
V <sub>eREF-</sub>	Negative external reference voltage input	V <sub>eREF+</sub> > V <sub>eREF-</sub> <sup>(3)</sup>		0	1.2	V
(V <sub>eREF+</sub> – V <sub>eREF-</sub> )	Differential external reference voltage input	V <sub>eREF+</sub> > V <sub>eREF-</sub> <sup>(4)</sup>		1.4	AV <sub>CC</sub>	V
I <sub>VeREF+</sub> , I <sub>VeREF-</sub>	Static input current	1.4 V ≤ V <sub>eREF+</sub> ≤ V <sub>AVCC</sub> , V <sub>eREF-</sub> = 0 V, f <sub>ADC10CLK</sub> = 5 MHz, ADC10SHTX = 0x0001, Conversion rate = 200 kpsps	2.2 V, 3 V	-26	26	μA
		1.4 V ≤ V <sub>eREF+</sub> ≤ V <sub>AVCC</sub> , V <sub>eREF-</sub> = 0 V, f <sub>ADC10CLK</sub> = 5 MHz, ADC10SHTX = 0x1000, Conversion rate = 20 kpsps	2.2 V, 3 V	-1	1	
C <sub>VeREF+</sub> , C <sub>VeREF-</sub>	Capacitance at VeREF+ or VeREF- terminal	<sup>(5)</sup>		10		μF

- (1) The external reference is used during ADC conversion to charge and discharge the capacitance array. The input capacitance (C<sub>I</sub>) is also the dynamic load for an external reference during conversion. The dynamic impedance of the reference supply should follow the recommendations on analog-source impedance to allow the charge to settle for 10-bit accuracy.
- (2) The accuracy limits the minimum positive external reference voltage. Lower reference voltage levels may be applied with reduced accuracy requirements.
- (3) The accuracy limits the maximum negative external reference voltage. Higher reference voltage levels may be applied with reduced accuracy requirements.
- (4) The accuracy limits minimum external differential reference voltage. Lower differential reference voltage levels may be applied with reduced accuracy requirements.
- (5) Two decoupling capacitors, 10 μF and 100 nF, should be connected to VREF to decouple the dynamic current required for an external reference source if it is used for the ADC10\_A. See also the [MSP430F5xx and MSP430F6xx Family User's Guide](#).

## 5.45 REF, Built-In Reference

over recommended ranges of supply voltage and operating free-air temperature (unless otherwise noted)<sup>(1)</sup>

PARAMETER	TEST CONDITIONS	V <sub>CC</sub>	MIN	TYP	MAX	UNIT
V <sub>REF+</sub>	REFVSEL = {2} for 2.5 V, REFON = 1	3 V	2.472	2.51	2.548	V
	REFVSEL = {1} for 2.0 V, REFON = 1	3 V	1.96	1.99	2.02	
	REFVSEL = {0} for 1.5 V, REFON = 1	2.2 V, 3 V	1.472	1.495	1.518	
AV <sub>CC(min)</sub>	REFVSEL = {0} for 1.5 V		1.8			V
	REFVSEL = {1} for 2.0 V		2.2			
	REFVSEL = {2} for 2.5 V		2.7			
I <sub>REF+</sub>	f <sub>ADC10CLK</sub> = 5.0 MHz, REFON = 1, REFBURST = 0, REFVSEL = {2} for 2.5 V	3 V		18	24	μA
	f <sub>ADC10CLK</sub> = 5.0 MHz, REFON = 1, REFBURST = 0, REFVSEL = {1} for 2.0 V	3 V		15.5	21	
	f <sub>ADC10CLK</sub> = 5.0 MHz, REFON = 1, REFBURST = 0, REFVSEL = {0} for 1.5 V	3 V		13.5	21	
TC <sub>REF+</sub>	I <sub>VREF+</sub> = 0 A, REFVSEL = {0, 1, 2}, REFON = 1			30	50	ppm/ °C
I <sub>SENSOR</sub>	REFON = 0, INCH = 0Ah, ADC10ON = N A, T <sub>A</sub> = 30°C	2.2 V		20	22	μA
		3 V		20	22	
V <sub>SENSOR</sub>	See <sup>(5)</sup>	2.2 V		770		mV
		3 V		770		
V <sub>MID</sub>	ADC10ON = 1, INCH = 0Bh, V <sub>MID</sub> ≈ 0.5 × V <sub>AVCC</sub>	2.2 V	1.06	1.1	1.14	V
		3 V	1.46	1.5	1.54	
t <sub>SENSOR(sample)</sub>	ADC10ON = 1, INCH = 0Ah, Error of conversion result ≤ 1 LSB			30		μs
t <sub>V<sub>MID</sub>(sample)</sub>	ADC10ON = 1, INCH = 0Bh, Error of conversion result ≤ 1 LSB			1		μs
PSRR <sub>DC</sub>	AV <sub>CC</sub> = AV <sub>CC(min)</sub> to AV <sub>CC(max)</sub> , T <sub>A</sub> = 25°C, REFVSEL = {0, 1, 2}, REFON = 1			120		μV/V
PSRR <sub>AC</sub>	AV <sub>CC</sub> = AV <sub>CC(min)</sub> to AV <sub>CC(max)</sub> , T <sub>A</sub> = 25°C, f = 1 kHz, ΔV <sub>pp</sub> = 100 mV REFVSEL = {0, 1, 2}, REFON = 1			6.4		mV/V
t <sub>SETTLE</sub>	AV <sub>CC</sub> = AV <sub>CC(min)</sub> to AV <sub>CC(max)</sub> REFVSEL = {0, 1, 2}, REFON = 0 → 1			75		μs

- (1) The leakage current is defined in the leakage current table with P6.x/Ax parameter.
- (2) The internal reference current is supplied from terminal AVCC. Consumption is independent of the ADC10ON control bit, unless a conversion is active. The REFON bit enables to settle the built-in reference before starting an analog-to-digital conversion.
- (3) Calculated using the box method: (MAX(−40°C to 85°C) − MIN(−40°C to 85°C)) / MIN(−40°C to 85°C)/(85°C − (−40°C)).
- (4) The sensor current I<sub>SENSOR</sub> is consumed if (ADC10ON = 1 and REFON = 1) or (ADC10ON = 1 and INCH = 0Ah and sample signal is high). When REFON = 1, I<sub>SENSOR</sub> is already included in I<sub>REF+</sub>.
- (5) The temperature sensor offset can be significant. TI recommends a single-point calibration to minimize the offset error of the built-in temperature sensor.
- (6) The typical equivalent impedance of the sensor is 51 kΩ. The sample time required includes the sensor-on time t<sub>SENSOR(on)</sub>.
- (7) The on-time t<sub>V<sub>MID</sub>(on)</sub> is included in the sampling time t<sub>V<sub>MID</sub>(sample)</sub>; no additional on time is needed.
- (8) The condition is that the error in a conversion started after t<sub>REFON</sub> is less than ±0.5 LSB.

## 5.46 Comparator\_B

over recommended ranges of supply voltage and operating free-air temperature (unless otherwise noted)

PARAMETER	TEST CONDITIONS	V <sub>CC</sub>	MIN	TYP	MAX	UNIT	
V <sub>CC</sub>	Supply voltage		1.8		3.6	V	
I <sub>AVCC_COMP</sub>	Comparator operating supply current into AVCC, excludes reference resistor ladder	CBPWRMD = 00, CBON = 1, CBRsX = 00	1.8 V		38	μA	
			2.2 V		31		
			3 V		32		
		2.2 V, 3 V		10	17		
	CBPWRMD = 10, CBON = 1, CBRsX = 00	2.2 V, 3 V		0.2	0.85		
V <sub>REF</sub>	Reference voltage level		CBREFLx = 01, CBREFACC = 0	≥ 1.8 V	1.44	±2.5%	V
			CBREFLx = 10, CBREFACC = 0	≥ 2.2 V	1.92	±2.5%	
			CBREFLx = 11, CBREFACC = 0	≥ 3.0 V	2.39	±2.5%	
I <sub>AVCC_REF</sub>	Quiescent current of resistor ladder into AVCC, including REF module current		CBREFACC = 1, CBREFLx = 01, CBRsX = 10, REFON = 0, CBON = 0	2.2 V, 3 V	17	22	μA
			CBREFACC = 0, CBREFLx = 01, CBRsX = 10, REFON = 0, CBON = 0	2.2 V, 3 V	33	40	
V <sub>IC</sub>	Common mode input range		0		V <sub>CC</sub> – 1	V	
V <sub>OFFSET</sub>	Input offset voltage		CBPWRMD = 00		–20	20	mV
			CBPWRMD = 01 or 10		–10	10	
C <sub>IN</sub>	Input capacitance			5		pF	
R <sub>SIN</sub>	Series input resistance		On (switch closed)		3	4	kΩ
			Off (switch open)	50			MΩ
t <sub>PD</sub>	Propagation delay, response time		CBPWRMD = 00, CBF = 0			450	ns
			CBPWRMD = 01, CBF = 0			600	
			CBPWRMD = 10, CBF = 0			50	
t <sub>PD,filter</sub>	Propagation delay with filter active		CBPWRMD = 00, CBON = 1, CBF = 1, CBF <sub>DLY</sub> = 00	0.35	0.6	1.5	μs
			CBPWRMD = 00, CBON = 1, CBF = 1, CBF <sub>DLY</sub> = 01	0.6	1.0	1.8	
			CBPWRMD = 00, CBON = 1, CBF = 1, CBF <sub>DLY</sub> = 10	1.0	1.8	3.4	
			CBPWRMD = 00, CBON = 1, CBF = 1, CBF <sub>DLY</sub> = 11	1.8	3.4	6.5	
t <sub>EN_CMP</sub>	Comparator enable time		CBON = 0 → 1, CBPWRMD = 00 or 01		1	2	μs
			CBON = 0 → 1, CBPWRMD = 10			100	
t <sub>EN_REF</sub>	Resistor reference enable time		CBON = 0 → 1		1.0	1.5	μs
TC <sub>CB_REF</sub>	Temperature coefficient reference of V <sub>CB_REF</sub>				50	ppm/°C	
V <sub>CB_REF</sub>	Reference voltage for a given tap	V <sub>IN</sub> = reference into resistor ladder, n = 0 to 31		$\frac{V_{IN} \times (n + 0.5)}{32}$	$\frac{V_{IN} \times (n + 1)}{32}$	$\frac{V_{IN} \times (n + 1.5)}{32}$	V

## 5.47 Flash Memory

over recommended ranges of supply voltage and operating free-air temperature (unless otherwise noted)

PARAMETER		T <sub>J</sub>	MIN	TYP	MAX	UNIT
DV <sub>CC(PGM/ERASE)</sub>	Program and erase supply voltage		1.8		3.6	V
I <sub>PGM</sub>	Average supply current from DV <sub>CC</sub> during program			3	5	mA
I <sub>ERASE</sub>	Average supply current from DV <sub>CC</sub> during erase			6	11	mA
I <sub>MERASE, IBANK</sub>	Average supply current from DV <sub>CC</sub> during mass erase or bank erase			6	11	mA
t <sub>CPT</sub>	Cumulative program time <sup>(1)</sup>				16	ms
	Program and erase endurance		10 <sup>4</sup>	10 <sup>5</sup>		cycles
t <sub>Retention</sub>	Data retention duration	25°C	100			years
t <sub>Word</sub>	Word or byte program time <sup>(2)</sup>		64		85	μs
t <sub>Block, 0</sub>	Block program time for first byte or word <sup>(2)</sup>		49		65	μs
t <sub>Block, 1–(N–1)</sub>	Block program time for each additional byte or word, except for last byte or word <sup>(2)</sup>		37		49	μs
t <sub>Block, N</sub>	Block program time for last byte or word <sup>(2)</sup>		55		73	μs
t <sub>Erase</sub>	Erase time for segment, mass erase, and bank erase when available <sup>(2)</sup>		23		32	ms
f <sub>MCLK,MGR</sub>	MCLK frequency in marginal read mode (FCTL4.MGR0 = 1 or FCTL4.MGR1 = 1)		0		1	MHz

(1) The cumulative program time must not be exceeded when writing to a 128-byte flash block. This parameter applies to all programming methods: individual word or byte write mode and block write mode.

(2) These values are hardwired into the state machine of the flash controller.

## 5.48 JTAG and Spy-Bi-Wire Interface

over recommended ranges of supply voltage and operating free-air temperature (unless otherwise noted)

PARAMETER		V <sub>CC</sub>	V <sub>IO</sub>	MIN	TYP	MAX	UNIT
f <sub>SBW</sub>	Spy-Bi-Wire input frequency	2.2 V, 3 V	1.62 V to 1.98 V	0		20	MHz
t <sub>SBW,Low</sub>	Spy-Bi-Wire low clock pulse duration	2.2 V, 3 V	1.62 V to 1.98 V	0.025		15	μs
t <sub>SBW,En</sub>	Spy-Bi-Wire enable time (TEST high to acceptance of first clock edge) <sup>(1)</sup>	2.2 V, 3 V	1.62 V to 1.98 V			1	μs
t <sub>SBW,Rst</sub>	Spy-Bi-Wire return to normal operation time	2.2 V, 3 V	1.62 V to 1.98 V	15		100	μs
f <sub>TCK</sub>	TCK input frequency for 4-wire JTAG <sup>(2)</sup>	2.2 V	1.62 V to 1.98 V	0		5	MHz
		3 V	1.62 V to 1.98 V	0		10	
R <sub>internal</sub>	Internal pulldown resistance on TEST	2.2 V, 3 V	1.62 V to 1.98 V	45	60	80	kΩ

(1) Tools that access the Spy-Bi-Wire interface must wait for the t<sub>SBW,En</sub> time after pulling the TEST/SBWTCK pin high before applying the first SBWTCK clock edge.

(2) f<sub>TCK</sub> may be restricted to meet the timing requirements of the module selected.

### 5.49 DVIO BSL Entry

over recommended ranges of supply voltage and operating free-air temperature (unless otherwise noted)

PARAMETER		V <sub>CC</sub>	V <sub>IO</sub>	MIN	MAX	UNIT
t <sub>SU, BSL</sub>	Setup time BSL to $\overline{\text{RST/NMI}}$ <sup>(1)</sup>	2.2 V, 3 V	1.62 V to 1.98 V	100		ns
t <sub>HO, BSL</sub>	Hold time BSL to $\overline{\text{RST/NMI}}$ <sup>(2)</sup>	2.2 V, 3 V	1.62 V to 1.98 V	350		μs

- (1) AVCC, DVCC, and DVIO stable and within specification.
- (2) BSL must remain logic high long enough for the boot code to detect its level and enter the BSL sequence. After the minimum hold time is achieved, BSL is a don't care.

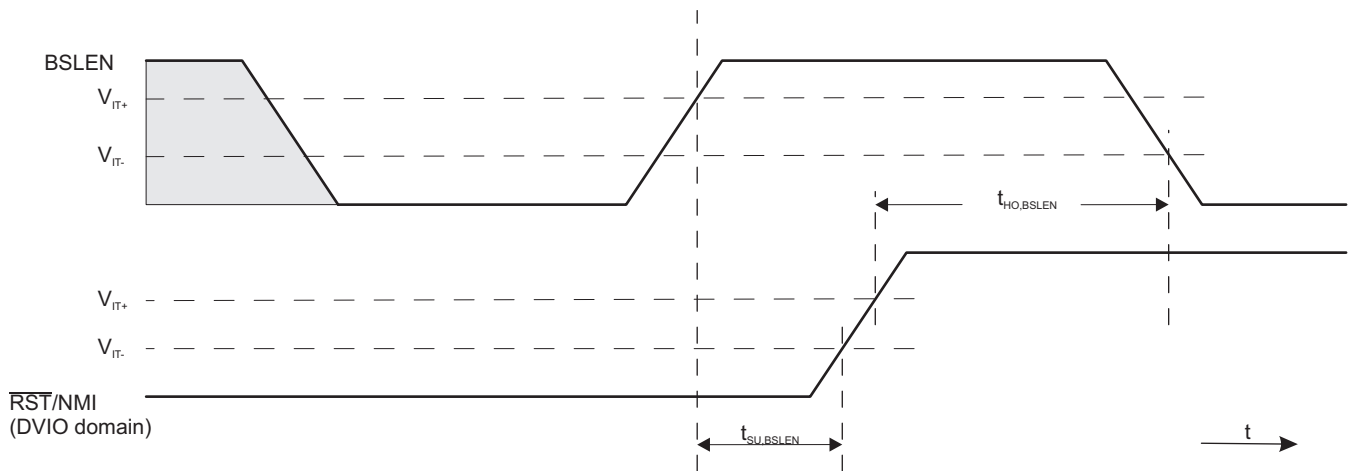

Figure 5-18. DVIO BSL Entry Timing

## 6 Detailed Description

### 6.1 CPU ([Link to user's guide](#))

The MSP430 CPU has a 16-bit RISC architecture that is highly transparent to the application. All operations, other than program-flow instructions, are performed as register operations in conjunction with seven addressing modes for source operand and four addressing modes for destination operand.

The CPU is integrated with 16 registers that provide reduced instruction execution time. The register-to-register operation execution time is one cycle of the CPU clock.

Four of the registers, R0 to R3, are dedicated as program counter, stack pointer, status register, and constant generator, respectively. The remaining registers are general-purpose registers (see [Figure 6-1](#)).

Peripherals are connected to the CPU using data, address, and control buses. Peripherals can be handled with all instructions.

The instruction set consists of the original 51 instructions with three formats and seven address modes and additional instructions for the expanded address range. Each instruction can operate on word and byte data.

Program Counter	PC/R0
Stack Pointer	SP/R1
Status Register	SR/CG1/R2
Constant Generator	CG2/R3
General-Purpose Register	R4
General-Purpose Register	R5
General-Purpose Register	R6
General-Purpose Register	R7
General-Purpose Register	R8
General-Purpose Register	R9
General-Purpose Register	R10
General-Purpose Register	R11
General-Purpose Register	R12
General-Purpose Register	R13
General-Purpose Register	R14
General-Purpose Register	R15

**Figure 6-1. CPU Registers**

## 6.2 Operating Modes

These MCUs have one active mode and six software selectable low-power modes of operation. An interrupt event can wake up the device from any of the low-power modes, service the request, and restore back to the low-power mode on return from the interrupt program.

Software can configure the following operating modes:

- Active mode (AM)
  - All clocks are active
- Low-power mode 0 (LPM0)
  - CPU is disabled
  - ACLK and SMCLK remain active, MCLK is disabled
  - FLL loop control remains active
- Low-power mode 1 (LPM1)
  - CPU is disabled
  - FLL loop control is disabled
  - ACLK and SMCLK remain active, MCLK is disabled
- Low-power mode 2 (LPM2)
  - CPU is disabled
  - MCLK, FLL loop control, and DCOCLK are disabled
  - DCO dc-generator remains enabled
  - ACLK remains active
- Low-power mode 3 (LPM3)
  - CPU is disabled
  - MCLK, FLL loop control, and DCOCLK are disabled
  - DCO dc generator is disabled
  - ACLK remains active
- Low-power mode 4 (LPM4)
  - CPU is disabled
  - ACLK is disabled
  - MCLK, FLL loop control, and DCOCLK are disabled
  - DCO dc generator is disabled
  - Crystal oscillator is stopped
  - Complete data retention
- Low-power mode 4.5 (LPM4.5)
  - Internal regulator disabled
  - No data retention
  - Wake-up signal from  $\overline{\text{RST}}/\text{NMI}$ , P1, and P2

### 6.3 Interrupt Vector Addresses

The interrupt vectors and the power-up start address are in the address range 0FFFFh to 0FF80h (see [Table 6-1](#)). The vector contains the 16-bit address of the appropriate interrupt-handler instruction sequence.

**Table 6-1. Interrupt Sources, Flags, and Vectors**

INTERRUPT SOURCE	INTERRUPT FLAG	SYSTEM INTERRUPT	WORD ADDRESS	PRIORITY
<b>System Reset</b> Power up External reset Watchdog time-out, password violation Flash memory password violation PMM password violation	WDTIFG, KEYV (SYSRSTIV) <sup>(1)(2)</sup>	Reset	0FFFEh	63, highest
<b>System NMI</b> PMM Vacant memory access JTAG mailbox	SVMLIFG, SVMHIFG, DLYLIFG, DLYHIFG, VLRIFG, VLRHIFG, VMAIFG, JMBNIFG, JMBOUTIFG (SYSSNIV) <sup>(1)</sup>	(Non)maskable	0FFFCh	62
<b>User NMI</b> NMI Oscillator fault Flash memory access violation	NMIIFG, OFIFG, ACCVIFG, BUSIFG (SYSUNIV) <sup>(1)(2)</sup>	(Non)maskable	0FFFAh	61
COMP_B	Comparator B interrupt flags (CBIV) <sup>(1)(3)</sup>	Maskable	0FFF8h	60
TB0	TB0CCR0 CCIFG0 <sup>(3)</sup>	Maskable	0FFF6h	59
TB0	TB0CCR1 CCIFG1 to TB0CCR6 CCIFG6, TB0IFG (TB0IV) <sup>(1)(3)</sup>	Maskable	0FFF4h	58
Watchdog timer interval timer mode	WDTIFG	Maskable	0FFF2h	57
USCI_A0 receive or transmit	UCA0RXIFG, UCA0TXIFG (UCA0IV) <sup>(1)(3)</sup>	Maskable	0FFF0h	56
USCI_B0 receive or transmit	UCB0RXIFG, UCB0TXIFG (UCB0IV) <sup>(1)(3)</sup>	Maskable	0FFEEh	55
ADC10_A	ADC10IFG0 <sup>(1)(3)(4)</sup>	Maskable	0FFECCh	54
TA0	TA0CCR0 CCIFG0 <sup>(3)</sup>	Maskable	0FFEAh	53
TA0	TA0CCR1 CCIFG1 to TA0CCR4 CCIFG4, TA0IFG (TA0IV) <sup>(1)(3)</sup>	Maskable	0FFE8h	52
Reserved	Reserved	Maskable	0FFE6h	51
DMA	DMA0IFG, DMA1IFG, DMA2IFG (DMAIV) <sup>(1)(3)</sup>	Maskable	0FFE4h	50
TA1	TA1CCR0 CCIFG0 <sup>(3)</sup>	Maskable	0FFE2h	49
TA1	TA1CCR1 CCIFG1 to TA1CCR2 CCIFG2, TA1IFG (TA1IV) <sup>(1)(3)</sup>	Maskable	0FFE0h	48
I/O Port P1	P1IFG.0 to P1IFG.7 (P1IV) <sup>(1)(3)</sup>	Maskable	0FFDEh	47
USCI_A1 receive or transmit	UCA1RXIFG, UCA1TXIFG (UCA1IV) <sup>(1)(3)</sup>	Maskable	0FFDCh	46
USCI_B1 receive or transmit	UCB1RXIFG, UCB1TXIFG (UCB1IV) <sup>(1)(3)</sup>	Maskable	0FFDAh	45
TA2	TA2CCR0 CCIFG0 <sup>(3)</sup>	Maskable	0FFD8h	44
TA2	TA2CCR1 CCIFG1 to TA2CCR2 CCIFG2, TA2IFG (TA2IV) <sup>(1)(3)</sup>	Maskable	0FFD6h	43
I/O port P2	P2IFG.0 to P2IFG.7 (P2IV) <sup>(1)(3)</sup>	Maskable	0FFD4h	42
RTC_A	RTCRDYIFG, RTCTEVIFG, RTCAIFG, RT0PSIFG, RT1PSIFG (RTCIV) <sup>(1)(3)</sup>	Maskable	0FFD2h	41

(1) Multiple source flags

(2) A reset is generated if the CPU tries to fetch instructions from within peripheral space or vacant memory space.

(Non)maskable: the individual interrupt-enable bit can disable an interrupt event, but the general-interrupt enable cannot disable it.

(3) Interrupt flags are located in the module.

(4) Only on devices with ADC, otherwise reserved

**Table 6-1. Interrupt Sources, Flags, and Vectors (continued)**

INTERRUPT SOURCE	INTERRUPT FLAG	SYSTEM INTERRUPT	WORD ADDRESS	PRIORITY
Reserved	Reserved <sup>(5)</sup>		0FFD0h	40
			⋮	⋮
			0FF80h	0, lowest

(5) Reserved interrupt vectors at addresses are not used in this device and can be used for regular program code if necessary. To maintain compatibility with other devices, TI recommends reserving these locations.

## 6.4 Memory Organization

Table 6-2 summarizes the memory map.

**Table 6-2. Memory Organization<sup>(1)</sup>**

		MSP430F5227 MSP430F5222 MSP430F5217 MSP430F5212	MSP430F5229 MSP430F5224 MSP430F5219 MSP430F5214
Memory (flash) Main: interrupt vector	Total Size	64KB 00FFFFh to 00FF80h	128KB 00FFFFh to 00FF80h
Main: code memory	Bank D	N/A	32KB 0243FFh to 01C400h
	Bank C	N/A	32KB 01C3FFh to 014400h
	Bank B	32KB 0143FFh to 00C400h	32KB 0143FFh to 00C400h
	Bank A	32KB 00C3FFh to 004400h	32KB 00C3FFh to 004400h
RAM	Sector 3	2KB 0043FFh to 003C00h	2KB 0043FFh to 003C00h
	Sector 2	2KB 003BFFh to 003400h	2KB 003BFFh to 003400h
	Sector 1	2KB 0033FFh to 002C00h	2KB 0033FFh to 002C00h
	Sector 0	2KB 002BFFh to 002400h	2KB 002BFFh to 002400h
TI factory memory (ROM)	A	128 B 001BFFh to 001B80h	128 B 001BFFh to 001B80h
	B	128 B 001B7Fh to 001B00h	128 B 001B7Fh to 001B00h
	C	128 B 001AFFh to 001A80h	128 B 001AFFh to 001A80h
	D	128 B 001A7Fh to 001A00h	128 B 001A7Fh to 001A00h
Information memory (flash)	Info A	128 B 0019FFh to 001980h	128 B 0019FFh to 001980h
	Info B	128 B 00197Fh to 001900h	128 B 00197Fh to 001900h
	Info C	128 B 0018FFh to 001880h	128 B 0018FFh to 001880h
	Info D	128 B 00187Fh to 001800h	128 B 00187Fh to 001800h

(1) N/A = Not available

**Table 6-2. Memory Organization<sup>(1)</sup> (continued)**

		<b>MSP430F5227 MSP430F5222 MSP430F5217 MSP430F5212</b>	<b>MSP430F5229 MSP430F5224 MSP430F5219 MSP430F5214</b>
Bootloader (BSL) memory (flash)	BSL 3	512 B 0017FFh to 001600h	512 B 0017FFh to 001600h
	BSL 2	512 B 0015FFh to 001400h	512 B 0015FFh to 001400h
	BSL 1	512 B 0013FFh to 001200h	512 B 0013FFh to 001200h
	BSL 0	512 B 0011FFh to 001000h	512 B 0011FFh to 001000h
Peripherals	Size	4KB 000FFFh to 0h	4KB 000FFFh to 0h

## 6.5 Bootloader (BSL)

The BSL enables users to program the flash memory or RAM using a UART serial interface. Access to the device memory by the BSL is protected by an user-defined password. Because the F522x and F521x have split I/O power domains, it is possible to interface with the BSL from either the DVCC or DVIO supply domains. This is useful when the MSP430 is interfacing to a host on the DVIO supply domain. The BSL interface on the DVIO supply domain (see [Table 6-3](#)) uses the USCI\_A0 module configured as a UART. The BSL interface on the DVCC supply domain (see [Table 6-4](#)) uses a timer-based UART.

### NOTE

Devices from TI come factory programmed with the timer-based UART BSL only. If the USCI-based BSL is preferred, it is also available, but it must be programmed by the user.

When using the DVIO supply domain for the BSL, entry to the BSL requires a specific sequence on the  $\overline{\text{RST}}/\text{NMI}$  and BSLLEN pins. [Table 6-3](#) shows the required pins and their functions. For further details on interfacing to development tools and device programmers, see the [MSP430 Hardware Tools User's Guide](#). For a complete description of the features of the BSL and its implementation, see the [MSP430 Flash Device Bootloader \(BSL\) User's Guide](#). The BSL on the DVIO supply domain uses the USCI\_A0 module configured as a UART.

### NOTE

To invoke the BSL from the DVIO domain, the  $\overline{\text{RST}}/\text{NMI}$  and BSLLEN pins must be used for the entry sequence (see [Section 5.49](#)). It is critical not to confuse the  $\overline{\text{RST}}/\text{NMI}$  pin with the  $\overline{\text{RSTDVCC}}/\text{SBWTDIO}$  pin. In other MSP430 devices, SBWTDIO is shared with the  $\overline{\text{RST}}/\text{NMI}$  pin and  $\overline{\text{RSTDVCC}}$  does not exist. Additional information can be found in [Designing With MSP430F522x and MSP430F521x Devices](#).

**Table 6-3. DVIO BSL Pin Requirements and Functions**

DEVICE SIGNAL	BSL FUNCTION
$\overline{\text{RST}}/\text{NMI}$	External reset
BSLEN	Enable BSL
P3.3	Data transmit
P3.4	Data receive
DVCC, AVCC	Device power supply
DVIO	I/O power supply
DVSS	Ground supply

For applications in which it is desirable to have BSL communication based on the DVCC supply domain, entry to the BSL requires a specific sequence on the  $\overline{\text{RSTDVCC}}/\text{SBWTDIO}$  and TEST/SBWTDIO pins. [Table 6-4](#) shows the required pins and their function.

### NOTE

To invoke the BSL from the DVCC domain, the  $\overline{\text{RSTDVCC}}/\text{SBWTDIO}$  and TEST/SBWTDIO pins must be used for the entry sequence. It is critical not to confuse the  $\overline{\text{RST}}/\text{NMI}$  pin with the  $\overline{\text{RSTDVCC}}/\text{SBWTDIO}$  pin. In other MSP430 devices, SBWTDIO is shared with the  $\overline{\text{RST}}/\text{NMI}$  pin and  $\overline{\text{RSTDVCC}}$  does not exist. Additional information can be found in [Designing With MSP430F522x and MSP430F521x Devices](#).

**Table 6-4. DVCC BSL Pin Requirements and Functions**

DEVICE SIGNAL	BSL FUNCTION
$\overline{\text{RSTDVCC}}/\text{SBWTDIO}$	External reset
TEST/SBWTCK	Enable BSL
P1.1	Data transmit
P1.2	Data receive
DVCC, AVCC	Device power supply
DVIO	I/O power supply
DVSS	Ground supply

## 6.6 JTAG Operation

### 6.6.1 JTAG Standard Interface

The MSP430 family supports the standard JTAG interface which requires four signals for sending and receiving data. The JTAG signals are shared with general-purpose I/O. The TEST/SBWTCK pin is used to enable the JTAG signals. In addition to these signals, the  $\overline{\text{RSTDVCC}}/\text{SBWTDIO}$  is required to interface with MSP430 development tools and device programmers. The JTAG pin requirements are shown in [Table 6-5](#). For further details on interfacing to development tools and device programmers, see the [MSP430 Hardware Tools User's Guide](#). For a complete description of the features of the JTAG interface and its implementation, see [MSP430 Programming With the JTAG Interface](#). Additional information can be found in [Designing With MSP430F522x and MSP430F521x Devices](#).

---

#### NOTE

All JTAG I/O pins are supplied by DVCC.

---

#### NOTE

On other MSP430 devices, the  $\overline{\text{RST}}/\text{NMI}$  pin has been used for SBWTDIO, so care must be taken not to mistakenly use the incorrect pin. On the F522x and F521x series of devices,  $\overline{\text{RSTDVCC}}$  is used for SBWTDIO as shown in [Table 6-5](#). Additional information can be found in [Designing With MSP430F522x and MSP430F521x Devices](#).

---

**Table 6-5. JTAG Pin Requirements and Functions**

DEVICE SIGNAL	DIRECTION	FUNCTION
PJ.3/TCK	IN	JTAG clock input
PJ.2/TMS	IN	JTAG state control
PJ.1/TDI/TCLK	IN	JTAG data input, TCLK input
PJ.0/TDO	OUT	JTAG data output
TEST/SBWTCK	IN	Enable JTAG pins
$\overline{\text{RSTDVCC}}/\text{SBWTDIO}$	IN	External reset
DVCC, AVCC		Device power supply
DVIO		I/O power supply
DVSS		Ground supply

## 6.6.2 Spy-Bi-Wire Interface

In addition to the standard JTAG interface, the MSP430 family supports the 2-wire Spy-Bi-Wire interface. Spy-Bi-Wire can be used to interface with MSP430 development tools and device programmers. The Spy-Bi-Wire interface pin requirements are shown in [Table 6-6](#). For further details on interfacing to development tools and device programmers, see the [MSP430 Hardware Tools User's Guide](#). For a complete description of the features of the JTAG interface and its implementation, see [MSP430 Programming With the JTAG Interface](#). Additional information can be found in [Designing With MSP430F522x and MSP430F521x Devices](#).

### NOTE

All SBW I/O pins are supplied by DVCC.

### NOTE

On other MSP430 devices, the  $\overline{\text{RST}}/\text{NMI}$  pin has been used for SBWTDIO, so care must be taken not to mistakenly use the incorrect pin. On the F522x and F521x series of devices,  $\overline{\text{RSTDVCC}}$  is used for SBWTDIO as shown in [Table 6-6](#). Additional information can be found in [Designing With MSP430F522x and MSP430F521x Devices](#).

**Table 6-6. Spy-Bi-Wire Pin Requirements and Functions**

DEVICE SIGNAL	DIRECTION	FUNCTION
TEST/SBWTK	IN	Spy-Bi-Wire clock input
$\overline{\text{RSTDVCC}}/\text{SBWTDIO}$	IN, OUT	Spy-Bi-Wire data input/output
DVCC, AVCC		Device power supply
DVIO		I/O power supply
DVSS		Ground supply

## 6.7 Flash Memory ([Link to user's guide](#))

The flash memory can be programmed through the JTAG port, Spy-Bi-Wire (SBW), the BSL, or in-system by the CPU. The CPU can perform single-byte, single-word, and long-word writes to the flash memory. Features of the flash memory include:

- Flash memory has n segments of main memory and four segments of information memory (A to D) of 128 bytes each. Each segment in main memory is 512 bytes in size.
- Segments 0 to n may be erased in one step, or each segment may be individually erased.
- Segments A to D can be erased individually. Segments A to D are also called *information memory*.
- Segment A can be locked separately.

## 6.8 RAM ([Link to user's guide](#))

The RAM is made up of n sectors. Each sector can be completely powered down to reduce leakage; however, all data is lost during power down. Features of the RAM include:

- RAM has n sectors. The sizes of the sectors can be found in [Section 6.4](#).
- Each sector 0 to n can be complete disabled; however, all data in a sector is lost when it is disabled.
- Each sector 0 to n automatically enters low-power retention mode when possible.

## 6.9 Peripherals

Peripherals are connected to the CPU through data, address, and control buses. Peripherals can be managed using all instructions. For complete module descriptions, see the [MSP430F5xx and MSP430F6xx Family User's Guide](#).

### 6.9.1 Digital I/O ([Link to user's guide](#))

- All individual I/O bits are independently programmable.
- Any combination of input, output, and interrupt conditions is possible.
- Pullup or pulldown on all ports is programmable.
- Drive strength on all ports is programmable.
- Edge-selectable interrupt and LPM4.5 wakeup input capability is available for all bits of ports P1 and P2.
- Read and write access to port-control registers is supported by all instructions.
- Ports can be accessed byte-wise or word-wise in pairs.

### 6.9.2 Port Mapping Controller ([Link to user's guide](#))

The port mapping controller allows the flexible and reconfigurable mapping of digital functions to port P4. [Table 6-7](#) lists the valid settings.

**Table 6-7. Port Mapping Mnemonics and Functions**

VALUE	PxMAPy MNEMONIC	INPUT PIN FUNCTION	OUTPUT PIN FUNCTION
0	PM_NONE	None	DVSS
1	PM_CBOUT0	–	COMP_B output
	PM_TB0CLK	TB0 clock input	–
2	PM_ADC10CLK	–	ADC10CLK
	PM_DMAE0	DMAE0 input	–
3	PM_SVMOUT	–	SVM output
	PM_TB0OUTH	TB0 high-impedance input TB0OUTH	–
4	PM_TB0CCR0A	TB0 CCR0 capture input CCI0A	TB0 CCR0 compare output Out0
5	PM_TB0CCR1A	TB0 CCR1 capture input CCI1A	TB0 CCR1 compare output Out1
6	PM_TB0CCR2A	TB0 CCR2 capture input CCI2A	TB0 CCR2 compare output Out2
7	PM_TB0CCR3A	TB0 CCR3 capture input CCI3A	TB0 CCR3 compare output Out3
8	PM_TB0CCR4A	TB0 CCR4 capture input CCI4A	TB0 CCR4 compare output Out4
9	PM_TB0CCR5A	TB0 CCR5 capture input CCI5A	TB0 CCR5 compare output Out5
10	PM_TB0CCR6A	TB0 CCR6 capture input CCI6A	TB0 CCR6 compare output Out6
11	PM_UCA1RXD	USCI_A1 UART RXD (direction controlled by USCI – input)	
	PM_UCA1SOMI	USCI_A1 SPI slave out master in (direction controlled by USCI)	
12	PM_UCA1TXD	USCI_A1 UART TXD (direction controlled by USCI – output)	
	PM_UCA1SIMO	USCI_A1 SPI slave in master out (direction controlled by USCI)	
13	PM_UCA1CLK	USCI_A1 clock input/output (direction controlled by USCI)	
	PM_UCB1STE	USCI_B1 SPI slave transmit enable (direction controlled by USCI)	
14	PM_UCB1SOMI	USCI_B1 SPI slave out master in (direction controlled by USCI)	
	PM_UCB1SCL	USCI_B1 I2C clock (open drain and direction controlled by USCI)	
15	PM_UCB1SIMO	USCI_B1 SPI slave in master out (direction controlled by USCI)	
	PM_UCB1SDA	USCI_B1 I2C data (open drain and direction controlled by USCI)	
16	PM_UCB1CLK	USCI_B1 clock input/output (direction controlled by USCI)	
	PM_UCA1STE	USCI_A1 SPI slave transmit enable (direction controlled by USCI)	
17	PM_CBOUT1	None	COMP_B output
18	PM_MCLK	None	MCLK

**Table 6-7. Port Mapping Mnemonics and Functions (continued)**

VALUE	PxMAPy MNEMONIC	INPUT PIN FUNCTION	OUTPUT PIN FUNCTION
19	PM_RTCCLK	None	RTCCLK output
20	PM_UCA0RXD	USCI_A0 UART RXD (direction controlled by USCI - input)	
	PM_UCA0SOMI	USCI_A0 SPI slave out master in (direction controlled by USCI)	
21	PM_UCA0TXD	USCI_A0 UART TXD (direction controlled by USCI - output)	
	PM_UCA0SIMO	USCI_A0 SPI slave in master out (direction controlled by USCI)	
22	PM_UCA0CLK	USCI_A0 clock input/output (direction controlled by USCI)	
	PM_UCB0STE	USCI_B0 SPI slave transmit enable (direction controlled by USCI)	
23	PM_UCB0SOMI	USCI_B0 SPI slave out master in (direction controlled by USCI)	
	PM_UCB0SCL	USCI_B0 I2C clock (open drain and direction controlled by USCI)	
24	PM_UCB0SIMO	USCI_B0 SPI slave in master out (direction controlled by USCI)	
	PM_UCB0SDA	USCI_B0 I2C data (open drain and direction controlled by USCI)	
25	PM_UCB0CLK	USCI_B0 clock input/output (direction controlled by USCI)	
	PM_UCA0STE	USCI_A0 SPI slave transmit enable (direction controlled by USCI)	
26 - 30	Reserved	None	DVSS
31 (0FFh) <sup>(1)</sup>	PM_ANALOG	Disables the output driver and the input Schmitt trigger to prevent parasitic cross currents when applying analog signals	

(1) The value of the PM\_ANALOG mnemonic is set to 0FFh. The port mapping registers are only 5 bits wide and the upper bits are ignored, resulting in a read out value of 31.

**Table 6-8. Default Mapping**

PIN	PxMAPy MNEMONIC	INPUT PIN FUNCTION	OUTPUT PIN FUNCTION
P4.0/P4MAP0	PM_UCB1STE/PM_UCA1CLK	USCI_B1 SPI slave transmit enable (direction controlled by USCI) USCI_A1 clock input/output (direction controlled by USCI)	
P4.1/P4MAP1	PM_UCB1SIMO/PM_UCB1SDA	USCI_B1 SPI slave in master out (direction controlled by USCI) USCI_B1 I2C data (open drain and direction controlled by USCI)	
P4.2/P4MAP2	PM_UCB1SOMI/PM_UCB1SCL	USCI_B1 SPI slave out master in (direction controlled by USCI) USCI_B1 I2C clock (open drain and direction controlled by USCI)	
P4.3/P4MAP3	PM_UCB1CLK/PM_UCA1STE	USCI_A1 SPI slave transmit enable (direction controlled by USCI) USCI_B1 clock input/output (direction controlled by USCI)	
P4.4/P4MAP4	PM_UCA1TXD/PM_UCA1SIMO	USCI_A1 UART TXD (Direction controlled by USCI - output) USCI_A1 SPI slave in master out (direction controlled by USCI)	
P4.5/P4MAP5	PM_UCA1RXD/PM_UCA1SOMI	USCI_A1 UART RXD (Direction controlled by USCI - input) USCI_A1 SPI slave out master in (direction controlled by USCI)	
P4.6/P4MAP6	PM_NONE	None	DVSS
P4.7/P4MAP7 <sup>(1)</sup>	PM_NONE	None	DVSS

(1) Not available on all devices

### 6.9.3 Oscillator and System Clock ([Link to user's guide](#))

The clock system in the MSP430F522x and MSP430F521x family of devices is supported by the Unified Clock System (UCS) module, which includes support for a 32-kHz watch crystal oscillator (XT1 LF mode) (XT1 HF mode is not supported), an internal very-low-power low-frequency oscillator (VLO), an internal trimmed low-frequency oscillator (REFO), an integrated internal digitally controlled oscillator (DCO), and a high-frequency crystal oscillator (XT2). The UCS module is designed to meet the requirements of both low system cost and low power consumption. The UCS module features digital frequency locked loop (FLL) hardware that, in conjunction with a digital modulator, stabilizes the DCO frequency to a programmable multiple of the selected FLL reference frequency. The internal DCO provides a fast turnon clock source and stabilizes in 3.5  $\mu$ s (typical). The UCS module provides the following clock signals:

- Auxiliary clock (ACLK), sourced from a 32-kHz watch crystal (XT1), a high-frequency crystal (XT2), the internal low-frequency oscillator (VLO), the trimmed low-frequency oscillator (REFO), or the internal digitally controlled oscillator DCO.
- Main clock (MCLK), the system clock used by the CPU. MCLK can be sourced by same sources made available to ACLK.
- Sub-Main clock (SMCLK), the subsystem clock used by the peripheral modules. SMCLK can be sourced by same sources made available to ACLK.
- ACLK/n, the buffered output of ACLK, ACLK/2, ACLK/4, ACLK/8, ACLK/16, ACLK/32.

### 6.9.4 Power-Management Module (PMM) ([Link to user's guide](#))

The PMM includes an integrated voltage regulator that supplies the core voltage to the device and contains programmable output levels to provide for power optimization. The PMM also includes supply voltage supervisor (SVS) and supply voltage monitoring (SVM) circuitry, and brownout protection. The brownout circuit is implemented to provide the proper internal reset signal to the device during power-on and power-off. The SVS and SVM circuitry detects if the supply voltage drops below a user-selectable level and supports both supply voltage supervision (the device is automatically reset) and supply voltage monitoring (the device is not automatically reset). SVS and SVM circuitry is available on the primary supply and core supply.

### 6.9.5 Hardware Multiplier ([Link to user's guide](#))

The multiplication operation is supported by a dedicated peripheral module. The module performs operations with 32-, 24-, 16-, and 8-bit operands. The module supports signed and unsigned multiplication as well as signed and unsigned multiply-and-accumulate operations.

### 6.9.6 Real-Time Clock (RTC\_A) ([Link to user's guide](#))

The RTC\_A module can be used as a general-purpose 32-bit counter (counter mode) or as an integrated real-time clock (RTC) (calendar mode). In counter mode, the RTC\_A also includes two independent 8-bit timers that can be cascaded to form a 16-bit timer or counter. Both timers can be read and written by software. Calendar mode integrates an internal calendar that compensates for months with less than 31 days and includes leap year correction. The RTC\_A also supports flexible alarm functions and offset-calibration hardware.

### 6.9.7 Watchdog Timer (WDT\_A) ([Link to user's guide](#))

The primary function of the WDT\_A module is to perform a controlled system restart after a software problem occurs. If the selected time interval expires, a system reset is generated. If the watchdog function is not needed in an application, the module can be configured as an interval timer and can generate interrupts at selected time intervals.

### 6.9.8 System Module (SYS) [\(Link to user's guide\)](#)

The SYS module handles many of the system functions within the device. These include power-on reset (POR) and power-up clear (PUC) handling, NMI source selection and management, reset interrupt vector generators, bootloader (BSL) entry mechanisms, and configuration management (device descriptors). It also includes a data exchange mechanism when using JTAG that is called a JTAG mailbox and that can be used in the application. [Table 6-9](#) lists the SYS module interrupt vector registers.

**Table 6-9. System Module Interrupt Vector Registers**

INTERRUPT VECTOR REGISTER	ADDRESS	INTERRUPT EVENT	VALUE	PRIORITY
SYSRSTIV, System Reset	019Eh	No interrupt pending	00h	
		Brownout (BOR)	02h	Highest
		$\overline{\text{RST}}$ /NMI (BOR)	04h	
		PMMSWBOR (BOR)	06h	
		Wakeup from LPMx.5	08h	
		Security violation (BOR)	0Ah	
		SVSL (POR)	0Ch	
		SVSH (POR)	0Eh	
		SVML_OVP (POR)	10h	
		SVMH_OVP (POR)	12h	
		PMMSWPOR (POR)	14h	
		WDT time-out (PUC)	16h	
		WDT password violation (PUC)	18h	
		KEYV flash password violation (PUC)	1Ah	
		Reserved	1Ch	
		Peripheral area fetch (PUC)	1Eh	
		PMM password violation (PUC)	20h	
Reserved	22h to 3Eh	Lowest		
SYSSNIV, System NMI	019Ch	No interrupt pending	00h	
		SVMLIFG	02h	Highest
		SVMHIFG	04h	
		SVSMLDLYIFG	06h	
		SVSMHDLYIFG	08h	
		VMAIFG	0Ah	
		JMBINIFG	0Ch	
		JMBOUTIFG	0Eh	
		SVMLVLRIFG	10h	
		SVMHVLRFIFG	12h	
		Reserved	14h to 1Eh	Lowest
		SYSUNIV, User NMI	019Ah	No interrupt pending
NMIIFG	02h			Highest
OFIFG	04h			
ACCVIFG	06h			
Reserved	08h			
Reserved	0Ah to 1Eh			Lowest

### 6.9.9 DMA Controller ([Link to user's guide](#))

The DMA controller allows movement of data from one memory address to another without CPU intervention. For example, the DMA controller can be used to move data from the ADC10\_A conversion memory to RAM. Using the DMA controller can increase the throughput of peripheral modules. The DMA controller reduces system power consumption by allowing the CPU to remain in sleep mode, without having to awaken to move data to or from a peripheral. [Table 6-10](#) lists the trigger assignments.

**Table 6-10. DMA Trigger Assignments<sup>(1)</sup>**

TRIGGER	CHANNEL		
	0	1	2
0	DMAREQ	DMAREQ	DMAREQ
1	TA0CCR0 CCIFG	TA0CCR0 CCIFG	TA0CCR0 CCIFG
2	TA0CCR2 CCIFG	TA0CCR2 CCIFG	TA0CCR2 CCIFG
3	TA1CCR0 CCIFG	TA1CCR0 CCIFG	TA1CCR0 CCIFG
4	TA1CCR2 CCIFG	TA1CCR2 CCIFG	TA1CCR2 CCIFG
5	TA2CCR0 CCIFG	TA2CCR0 CCIFG	TA2CCR0 CCIFG
6	TA2CCR2 CCIFG	TA2CCR2 CCIFG	TA2CCR2 CCIFG
7	TB0CCR0 CCIFG	TB0CCR0 CCIFG	TB0CCR0 CCIFG
8	TB0CCR2 CCIFG	TB0CCR2 CCIFG	TB0CCR2 CCIFG
9	Reserved	Reserved	Reserved
10	Reserved	Reserved	Reserved
11	Reserved	Reserved	Reserved
12	Reserved	Reserved	Reserved
13	Reserved	Reserved	Reserved
14	Reserved	Reserved	Reserved
15	Reserved	Reserved	Reserved
16	UCA0RXIFG	UCA0RXIFG	UCA0RXIFG
17	UCA0TXIFG	UCA0TXIFG	UCA0TXIFG
18	UCB0RXIFG	UCB0RXIFG	UCB0RXIFG
19	UCB0TXIFG	UCB0TXIFG	UCB0TXIFG
20	UCA1RXIFG	UCA1RXIFG	UCA1RXIFG
21	UCA1TXIFG	UCA1TXIFG	UCA1TXIFG
22	UCB1RXIFG	UCB1RXIFG	UCB1RXIFG
23	UCB1TXIFG	UCB1TXIFG	UCB1TXIFG
24	ADC10IFG0 <sup>(2)</sup>	ADC10IFG0 <sup>(2)</sup>	ADC10IFG0 <sup>(2)</sup>
25	Reserved	Reserved	Reserved
26	Reserved	Reserved	Reserved
27	Reserved	Reserved	Reserved
28	Reserved	Reserved	Reserved
29	MPY ready	MPY ready	MPY ready
30	DMA2IFG	DMA0IFG	DMA1IFG
31	DMAE0	DMAE0	DMAE0

(1) If a reserved trigger source is selected, no trigger is generated.

(2) Only on devices with ADC; reserved on devices without ADC

### 6.9.10 **Universal Serial Communication Interface (USCI) (Links to user's guide: [UART Mode](#), [SPI Mode](#), [I<sup>2</sup>C Mode](#))**

The USCI modules are used for serial data communication. The USCI module supports synchronous communication protocols such as SPI (3- or 4-pin) and I<sup>2</sup>C, and asynchronous communication protocols such as UART, enhanced UART with automatic baudrate detection, and IrDA. Each USCI module contains two portions, A and B.

The USCI\_An module provides support for SPI (3- or 4-pin), UART, enhanced UART, or IrDA.

The USCI\_Bn module provides support for SPI (3- or 4-pin) or I<sup>2</sup>C.

The MSP430F522x and MSP430F521x series include two complete USCI modules (n = 0, 1).

### 6.9.11 TA0 (Link to user's guide)

TA0 is a 16-bit timer/counter (Timer\_A type) with five capture/compare registers. TA0 can support multiple captures or compares, PWM outputs, and interval timing (see [Table 6-11](#)). TA0 also has extensive interrupt capabilities. Interrupts may be generated from the counter on overflow conditions and from each of the capture/compare registers.

**Table 6-11. TA0 Signal Connections**

INPUT PIN NUMBER		DEVICE INPUT SIGNAL	MODULE INPUT SIGNAL	MODULE BLOCK	MODULE OUTPUT SIGNAL	DEVICE OUTPUT SIGNAL	OUTPUT PIN NUMBER	
RGC, ZQE, YFF	RGZ						RGC, ZQE, YFF	RGZ
18, H2, B7-P1.0	13-P1.0	TA0CLK	TACLK	Timer	NA	NA		
		ACLK (internal)	ACLK					
		SMCLK (internal)	SMCLK					
18, H2, B7-P1.0	13-P1.0	TA0CLK	$\overline{\text{TACLK}}$					
19, H3, C7-P1.1	14-P1.1	TA0.0	CCI0A	CCR0	TA0	TA0.0	19, H3, C7-P1.1	14-P1.1
		DVSS	CCI0B					
		DVSS	GND					
		DVCC	V <sub>CC</sub>					
20, J3, C8-P1.2	15-P1.2	TA0.1	CCI1A	CCR1	TA1	TA0.1	20, J3, C8-P1.2	15-P1.2
		CBOUT (internal)	CCI1B				ADC10 (internal) ADC10SHSx = {1}	ADC10 (internal) ADC10SHSx = {1}
		DVSS	GND					
		DVCC	V <sub>CC</sub>					
21, G4, C6-P1.3	16-P1.3	TA0.2	CCI2A	CCR2	TA2	TA0.2	21, G4, C6-P1.3	16-P1.3
		ACLK (internal)	CCI2B					
		DVSS	GND					
		DVCC	V <sub>CC</sub>					
22, H4, C5-P1.4	17-P1.4	TA0.3	CCI3A	CCR3	TA3	TA0.3	22, H4, C5-P1.4	17-P1.4
		DVSS	CCI3B					
		DVSS	GND					
		DVCC	V <sub>CC</sub>					
23, J4, D8-P1.5	18-P1.5	TA0.4	CCI4A	CCR4	TA4	TA0.4	23, J4, D8-P1.5	18-P1.5
		DVSS	CCI4B					
		DVSS	GND					
		DVCC	V <sub>CC</sub>					

### 6.9.12 TA1 (Link to user's guide)

TA1 is a 16-bit timer/counter (Timer\_A type) with three capture/compare registers. TA1 can support multiple captures or compares, PWM outputs, and interval timing (see Table 6-12). TA1 also has extensive interrupt capabilities. Interrupts may be generated from the counter on overflow conditions and from each of the capture/compare registers.

Table 6-12. TA1 Signal Connections

INPUT PIN NUMBER		DEVICE INPUT SIGNAL	MODULE INPUT SIGNAL	MODULE BLOCK	MODULE OUTPUT SIGNAL	DEVICE OUTPUT SIGNAL	OUTPUT PIN NUMBER	
RGC, ZQE, YFF	RGZ						RGC, ZQE, YFF	RGZ
24, G5, D7-P1.6	19-P1.6	TA1CLK	TACLK	Timer	NA	NA		
		ACLK (internal)	ACLK					
		SMCLK (internal)	SMCLK					
24, G5, D7-P1.6	19-P1.6	TA1CLK	$\overline{\text{TACLK}}$					
25, H5, D6-P1.7	20-P1.7	TA1.0	CC10A	CCR0	TA0	TA1.0	25, H5, D6-P1.7	20-P1.7
		DVSS	CC10B					
		DVSS	GND					
		DVCC	V <sub>CC</sub>					
26, J5, E8-P2.0		TA1.1	CC11A	CCR1	TA1	TA1.1	26, J5, E8-P2.0	
		CBOUT (internal)	CC11B					
		DVSS	GND					
		DVCC	V <sub>CC</sub>					
27, G6, D5-P2.1		TA1.2	CC12A	CCR2	TA2	TA1.2	27, G6, D5-P2.1	
		ACLK (internal)	CC12B					
		DVSS	GND					
		DVCC	V <sub>CC</sub>					

### 6.9.13 TA2 (Link to user's guide)

TA2 is a 16-bit timer/counter (Timer\_A type) with three capture/compare registers. TA2 can support multiple captures or compares, PWM outputs, and interval timing (see [Table 6-13](#)). TA2 also has extensive interrupt capabilities. Interrupts may be generated from the counter on overflow conditions and from each of the capture/compare registers.

**Table 6-13. TA2 Signal Connections**

INPUT PIN NUMBER		DEVICE INPUT SIGNAL	MODULE INPUT SIGNAL	MODULE BLOCK	MODULE OUTPUT SIGNAL	DEVICE OUTPUT SIGNAL	OUTPUT PIN NUMBER	
RGC, ZQE, YFF	RGZ						RGC, ZQE, YFF	RGZ
28, J6, E7-P2.2		TA2CLK	TACLK	Timer	NA	NA		
		ACLK (internal)	ACLK					
		SMCLK (internal)	SMCLK					
		TA2CLK	$\overline{\text{TACLK}}$					
29, H6, F8-P2.3		TA2.0	CC10A	CCR0	TA0	TA2.0	29, H6, F8-P2.3	
		DVSS	CC10B					
		DVSS	GND					
		DVCC	V <sub>CC</sub>					
30, J7, E6-P2.4		TA2.1	CC11A	CCR1	TA1	TA2.1	30, J7, E6-P2.4	
		CBOUT (internal)	CC11B					
		DVSS	GND					
		DVCC	V <sub>CC</sub>					
31, J8, F7-P2.5		TA2.2	CC12A	CCR2	TA2	TA2.2	31, J8, F7-P2.5	
		ACLK (internal)	CC12B					
		DVSS	GND					
		DVCC	V <sub>CC</sub>					

### 6.9.14 TB0 (Link to user's guide)

TB0 is a 16-bit timer/counter (Timer\_B type) with seven capture/compare registers. TB0 can support multiple captures or compares, PWM outputs, and interval timing (see Table 6-14). TB0 also has extensive interrupt capabilities. Interrupts may be generated from the counter on overflow conditions and from each of the capture/compare registers.

**Table 6-14. TB0 Signal Connections**

INPUT PIN NUMBER		DEVICE INPUT SIGNAL	MODULE INPUT SIGNAL	MODULE BLOCK	MODULE OUTPUT SIGNAL	DEVICE OUTPUT SIGNAL	OUTPUT PIN NUMBER	
RGC, ZQE, YFF	RGZ						RGC, ZQE, YFF	RGZ
(1)	(1)	TB0CLK	TBCLK	Timer	NA	NA		
		ACLK (internal)	ACLK					
		SMCLK (internal)	SMCLK					
(1)	(1)	TB0CLK	TBCLK					
49, B8(9) <sub>i</sub> , H1-P7.0 <sup>(1)</sup>	(1)	TB0.0	CCI0A	CCR0	TB0	TB0.0	49, B8(9) <sub>i</sub> , H1-P7.0 <sup>(1)</sup>	(1)
49, B8(9) <sub>i</sub> , H1-P7.0 <sup>(1)</sup>	(1)	TB0.0	CCI0B				ADC10 (internal) ADC10SHSx = {2}	ADC10 (internal) ADC10SHSx = {2}
		DVSS	GND					
		DVCC	V <sub>CC</sub>					
50, A9, G2-P7.1 <sup>(1)</sup>	(1)	TB0.1	CCI1A	CCR1	TB1	TB0.1	50, A9, G2-P7.1 <sup>(1)</sup>	(1)
		CBOUT (internal)	CCI1B				ADC10 (internal) ADC10SHSx = {3}	ADC10 (internal) ADC10SHSx = {3}
		DVSS	GND					
		DVCC	V <sub>CC</sub>					
51, B7, F3-P7.2 <sup>(1)</sup>	(1)	TB0.2	CCI2A	CCR2	TB2	TB0.2	51, B7, F3-P7.2 <sup>(1)</sup>	(1)
51, B7, F3-P7.2 <sup>(1)</sup>	(1)	TB0.2	CCI2B					
		DVSS	GND					
		DVCC	V <sub>CC</sub>					
52, A8, G1-P7.3 <sup>(1)</sup>	(1)	TB0.3	CCI3A	CCR3	TB3	TB0.3	52, A8, G1-P7.3 <sup>(1)</sup>	(1)
52, A8, G1-P7.3 <sup>(1)</sup>	(1)	TB0.3	CCI3B					
		DVSS	GND					
		DVCC	V <sub>CC</sub>					
53, A7, F2-P7.4 <sup>(1)</sup>	(1)	TB0.4	CCI4A	CCR4	TB4	TB0.4	53, A7, F2-P7.4 <sup>(1)</sup>	(1)
53, A7, F2-P7.4 <sup>(1)</sup>	(1)	TB0.4	CCI4B					
		DVSS	GND					
		DVCC	V <sub>CC</sub>					
54, A6, F1-P7.5 <sup>(1)</sup>	(1)	TB0.5	CCI5A	CCR5	TB5	TB0.5	54, A6, F1-P7.5 <sup>(1)</sup>	(1)
54, A6, F1-P7.5 <sup>(1)</sup>	(1)	TB0.5	CCI5B					
		DVSS	GND					
		DVCC	V <sub>CC</sub>					
(1)	(1)	TB0.6	CCI6A	CCR6	TB6	TB0.6	(1)	(1)
		ACLK (internal)	CCI6B					
		DVSS	GND					
		DVCC	V <sub>CC</sub>					

(1) Timer functions can be assigned by the port mapping controller.

### 6.9.15 *Comparator\_B* ([Link to user's guide](#))

The primary function of the Comparator\_B module is to support precision slope analog-to-digital conversions, battery voltage supervision, and monitoring of external analog signals.

### 6.9.16 *ADC10\_A* ([Link to user's guide](#))

The ADC10\_A module supports fast 10-bit analog-to-digital conversions. The module implements a 10-bit SAR core, sample select control, reference generator, and a conversion result buffer. A window comparator with lower and upper limits allows CPU-independent result monitoring with three window comparator interrupt flags.

### 6.9.17 *CRC16* ([Link to user's guide](#))

The CRC16 module produces a signature based on a sequence of entered data values and can be used for data checking purposes. The CRC16 module signature is based on the CRC-CCITT standard.

### 6.9.18 *REF Voltage Reference* ([Link to user's guide](#))

The REF is responsible for generation of all critical reference voltages that can be used by the various analog peripherals in the device.

### 6.9.19 *Embedded Emulation Module (EEM) (S Version)* ([Link to user's guide](#))

The EEM supports real-time in-system debugging. The S version of the EEM has the following features:

- Three hardware triggers or breakpoints on memory access
- One hardware trigger or breakpoint on CPU register write access
- Up to four hardware triggers can be combined to form complex triggers or breakpoints
- One cycle counter
- Clock control on module level

## 6.9.20 Peripheral File Map

Table 6-15 lists the base address for the registers of each peripheral.

**Table 6-15. Peripherals**

MODULE NAME	BASE ADDRESS	OFFSET ADDRESS RANGE
Special Functions (see <a href="#">Table 6-16</a> )	0100h	000h-01Fh
PMM (see <a href="#">Table 6-17</a> )	0120h	000h-010h
Flash Control (see <a href="#">Table 6-18</a> )	0140h	000h-00Fh
CRC16 (see <a href="#">Table 6-19</a> )	0150h	000h-007h
RAM Control (see <a href="#">Table 6-20</a> )	0158h	000h-001h
Watchdog (see <a href="#">Table 6-21</a> )	015Ch	000h-001h
UCS (see <a href="#">Table 6-22</a> )	0160h	000h-01Fh
SYS (see <a href="#">Table 6-23</a> )	0180h	000h-01Fh
Shared Reference (see <a href="#">Table 6-24</a> )	01B0h	000h-001h
Port Mapping Control (see <a href="#">Table 6-25</a> )	01C0h	000h-002h
Port Mapping Port P4 (see <a href="#">Table 6-25</a> )	01E0h	000h-007h
Port P1, P2 (see <a href="#">Table 6-26</a> )	0200h	000h-01Fh
Port P3, P4 (see <a href="#">Table 6-27</a> )	0220h	000h-00Bh
Port P5, P6 (see <a href="#">Table 6-28</a> )	0240h	000h-00Bh
Port P7 (see <a href="#">Table 6-29</a> )	0260h	000h-00Bh
Port PJ (see <a href="#">Table 6-30</a> )	0320h	000h-01Fh
TA0 (see <a href="#">Table 6-31</a> )	0340h	000h-02Eh
TA1 (see <a href="#">Table 6-32</a> )	0380h	000h-02Eh
TB0 (see <a href="#">Table 6-33</a> )	03C0h	000h-02Eh
TA2 (see <a href="#">Table 6-34</a> )	0400h	000h-02Eh
Real-Time Clock (RTC_A) (see <a href="#">Table 6-35</a> )	04A0h	000h-01Bh
32-Bit Hardware Multiplier (see <a href="#">Table 6-36</a> )	04C0h	000h-02Fh
DMA General Control (see <a href="#">Table 6-37</a> )	0500h	000h-00Fh
DMA Channel 0 (see <a href="#">Table 6-37</a> )	0510h	000h-00Ah
DMA Channel 1 (see <a href="#">Table 6-37</a> )	0520h	000h-00Ah
DMA Channel 2 (see <a href="#">Table 6-37</a> )	0530h	000h-00Ah
USCI_A0 (see <a href="#">Table 6-38</a> )	05C0h	000h-01Fh
USCI_B0 (see <a href="#">Table 6-39</a> )	05E0h	000h-01Fh
USCI_A1 (see <a href="#">Table 6-40</a> )	0600h	000h-01Fh
USCI_B1 (see <a href="#">Table 6-41</a> )	0620h	000h-01Fh
ADC10_A (see <a href="#">Table 6-42</a> )	0740h	000h-01Fh
Comparator_B (see <a href="#">Table 6-43</a> )	08C0h	000h-00Fh

**Table 6-16. Special Function Registers (Base Address: 0100h)**

REGISTER DESCRIPTION	REGISTER	OFFSET
SFR interrupt enable	SFRIE1	00h
SFR interrupt flag	SFRIFG1	02h
SFR reset pin control	SFRRPCR	04h

**Table 6-17. PMM Registers (Base Address: 0120h)**

REGISTER DESCRIPTION	REGISTER	OFFSET
PMM control 0	PMMCTL0	00h
PMM control 1	PMMCTL1	02h
SVS high-side control	SVSMHCTL	04h
SVS low-side control	SVSMLCTL	06h
PMM interrupt flags	PMMIFG	0Ch
PMM interrupt enable	PMMIE	0Eh
PMM power mode 5 control	PM5CTL0	10h

**Table 6-18. Flash Control Registers (Base Address: 0140h)**

REGISTER DESCRIPTION	REGISTER	OFFSET
Flash control 1	FCTL1	00h
Flash control 3	FCTL3	04h
Flash control 4	FCTL4	06h

**Table 6-19. CRC16 Registers (Base Address: 0150h)**

REGISTER DESCRIPTION	REGISTER	OFFSET
CRC data input	CRC16DI	00h
CRC data input reverse byte	CRCDIRB	02h
CRC initialization and result	CRCINIRES	04h
CRC result reverse byte	CRCRESR	06h

**Table 6-20. RAM Control Registers (Base Address: 0158h)**

REGISTER DESCRIPTION	REGISTER	OFFSET
RAM control 0	RCCTL0	00h

**Table 6-21. Watchdog Registers (Base Address: 015Ch)**

REGISTER DESCRIPTION	REGISTER	OFFSET
Watchdog timer control	WDTCTL	00h

**Table 6-22. UCS Registers (Base Address: 0160h)**

REGISTER DESCRIPTION	REGISTER	OFFSET
UCS control 0	UCSCTL0	00h
UCS control 1	UCSCTL1	02h
UCS control 2	UCSCTL2	04h
UCS control 3	UCSCTL3	06h
UCS control 4	UCSCTL4	08h
UCS control 5	UCSCTL5	0Ah
UCS control 6	UCSCTL6	0Ch
UCS control 7	UCSCTL7	0Eh

**Table 6-22. UCS Registers (Base Address: 0160h) (continued)**

REGISTER DESCRIPTION	REGISTER	OFFSET
UCS control 8	UCSCTL8	10h
UCS control 9	UCSCTL9	12h

**Table 6-23. SYS Registers (Base Address: 0180h)**

REGISTER DESCRIPTION	REGISTER	OFFSET
System control	SYSCTL	00h
Bootloader configuration area	SYSBSLC	02h
JTAG mailbox control	SYSJMBC	06h
JTAG mailbox input 0	SYSJMBIO	08h
JTAG mailbox input 1	SYSJMBI1	0Ah
JTAG mailbox output 0	SYSJMBO0	0Ch
JTAG mailbox output 1	SYSJMBO1	0Eh
User NMI vector generator	SYSUNIV	1Ah
System NMI vector generator	SYSNIV	1Ch
Reset vector generator	SYSRSTIV	1Eh

**Table 6-24. Shared Reference Registers (Base Address: 01B0h)**

REGISTER DESCRIPTION	REGISTER	OFFSET
Shared reference control	REFCTL	00h

**Table 6-25. Port Mapping Registers  
(Base Address of Port Mapping Control: 01C0h, Port P4: 01E0h)**

REGISTER DESCRIPTION	REGISTER	OFFSET
Port mapping key/ID	PMAPKEYID	00h
Port mapping control	PMAPCTL	02h
Port P4.0 mapping	P4MAP0	00h
Port P4.1 mapping	P4MAP1	01h
Port P4.2 mapping	P4MAP2	02h
Port P4.3 mapping	P4MAP3	03h
Port P4.4 mapping	P4MAP4	04h
Port P4.5 mapping	P4MAP5	05h
Port P4.6 mapping	P4MAP6	06h
Port P4.7 mapping	P4MAP7	07h

**Table 6-26. Port P1, P2 Registers (Base Address: 0200h)**

REGISTER DESCRIPTION	REGISTER	OFFSET
Port P1 input	P1IN	00h
Port P1 output	P1OUT	02h
Port P1 direction	P1DIR	04h
Port P1 resistor enable	P1REN	06h
Port P1 drive strength	P1DS	08h
Port P1 selection	P1SEL	0Ah
Port P1 interrupt vector word	P1IV	0Eh
Port P1 interrupt edge select	P1IES	18h
Port P1 interrupt enable	P1IE	1Ah
Port P1 interrupt flag	P1IFG	1Ch

**Table 6-26. Port P1, P2 Registers (Base Address: 0200h) (continued)**

REGISTER DESCRIPTION	REGISTER	OFFSET
Port P2 input	P2IN	01h
Port P2 output	P2OUT	03h
Port P2 direction	P2DIR	05h
Port P2 resistor enable	P2REN	07h
Port P2 drive strength	P2DS	09h
Port P2 selection	P2SEL	0Bh
Port P2 interrupt vector word	P2IV	1Eh
Port P2 interrupt edge select	P2IES	19h
Port P2 interrupt enable	P2IE	1Bh
Port P2 interrupt flag	P2IFG	1Dh

**Table 6-27. Port P3, P4 Registers (Base Address: 0220h)**

REGISTER DESCRIPTION	REGISTER	OFFSET
Port P3 input	P3IN	00h
Port P3 output	P3OUT	02h
Port P3 direction	P3DIR	04h
Port P3 resistor enable	P3REN	06h
Port P3 drive strength	P3DS	08h
Port P3 selection	P3SEL	0Ah
Port P4 input	P4IN	01h
Port P4 output	P4OUT	03h
Port P4 direction	P4DIR	05h
Port P4 resistor enable	P4REN	07h
Port P4 drive strength	P4DS	09h
Port P4 selection	P4SEL	0Bh

**Table 6-28. Port P5, P6 Registers (Base Address: 0240h)**

REGISTER DESCRIPTION	REGISTER	OFFSET
Port P5 input	P5IN	00h
Port P5 output	P5OUT	02h
Port P5 direction	P5DIR	04h
Port P5 resistor enable	P5REN	06h
Port P5 drive strength	P5DS	08h
Port P5 selection	P5SEL	0Ah
Port P6 input	P6IN	01h
Port P6 output	P6OUT	03h
Port P6 direction	P6DIR	05h
Port P6 resistor enable	P6REN	07h
Port P6 drive strength	P6DS	09h
Port P6 selection	P6SEL	0Bh

**Table 6-29. Port P7 Registers (Base Address: 0260h)**

REGISTER DESCRIPTION	REGISTER	OFFSET
Port P7 input	P7IN	00h
Port P7 output	P7OUT	02h
Port P7 direction	P7DIR	04h

**Table 6-29. Port P7 Registers (Base Address: 0260h) (continued)**

REGISTER DESCRIPTION	REGISTER	OFFSET
Port P7 resistor enable	P7REN	06h
Port P7 drive strength	P7DS	08h
Port P7 selection	P7SEL	0Ah

**Table 6-30. Port J Registers (Base Address: 0320h)**

REGISTER DESCRIPTION	REGISTER	OFFSET
Port PJ input	PJIN	00h
Port PJ output	PJOUT	02h
Port PJ direction	PJDIR	04h
Port PJ resistor enable	PJREN	06h
Port PJ drive strength	PJDS	08h

**Table 6-31. TA0 Registers (Base Address: 0340h)**

REGISTER DESCRIPTION	REGISTER	OFFSET
TA0 control	TAOCTL	00h
Capture/compare control 0	TAOCTL0	02h
Capture/compare control 1	TAOCTL1	04h
Capture/compare control 2	TAOCTL2	06h
Capture/compare control 3	TAOCTL3	08h
Capture/compare control 4	TAOCTL4	0Ah
TA0 counter	TAOR	10h
Capture/compare 0	TAOCCR0	12h
Capture/compare 1	TAOCCR1	14h
Capture/compare 2	TAOCCR2	16h
Capture/compare 3	TAOCCR3	18h
Capture/compare 4	TAOCCR4	1Ah
TA0 expansion 0	TAOEX0	20h
TA0 interrupt vector	TAOIV	2Eh

**Table 6-32. TA1 Registers (Base Address: 0380h)**

REGISTER DESCRIPTION	REGISTER	OFFSET
TA1 control	TA1CTL	00h
Capture/compare control 0	TA1CTL0	02h
Capture/compare control 1	TA1CTL1	04h
Capture/compare control 2	TA1CTL2	06h
TA1 counter	TA1R	10h
Capture/compare 0	TA1CCR0	12h
Capture/compare 1	TA1CCR1	14h
Capture/compare 2	TA1CCR2	16h
TA1 expansion 0	TA1EX0	20h
TA1 interrupt vector	TA1IV	2Eh

**Table 6-33. TB0 Registers (Base Address: 03C0h)**

REGISTER DESCRIPTION	REGISTER	OFFSET
TB0 control	TBOCTL	00h
Capture/compare control 0	TBOCTL0	02h

**Table 6-33. TB0 Registers (Base Address: 03C0h) (continued)**

REGISTER DESCRIPTION	REGISTER	OFFSET
Capture/compare control 1	TB0CTL1	04h
Capture/compare control 2	TB0CTL2	06h
Capture/compare control 3	TB0CTL3	08h
Capture/compare control 4	TB0CTL4	0Ah
Capture/compare control 5	TB0CTL5	0Ch
Capture/compare control 6	TB0CTL6	0Eh
TB0 counter	TB0R	10h
Capture/compare 0	TB0CCR0	12h
Capture/compare 1	TB0CCR1	14h
Capture/compare 2	TB0CCR2	16h
Capture/compare 3	TB0CCR3	18h
Capture/compare 4	TB0CCR4	1Ah
Capture/compare 5	TB0CCR5	1Ch
Capture/compare 6	TB0CCR6	1Eh
TB0 expansion 0	TB0EX0	20h
TB0 interrupt vector	TB0IV	2Eh

**Table 6-34. TA2 Registers (Base Address: 0400h)**

REGISTER DESCRIPTION	REGISTER	OFFSET
TA2 control	TA2CTL	00h
Capture/compare control 0	TA2CTL0	02h
Capture/compare control 1	TA2CTL1	04h
Capture/compare control 2	TA2CTL2	06h
TA2 counter	TA2R	10h
Capture/compare 0	TA2CCR0	12h
Capture/compare 1	TA2CCR1	14h
Capture/compare 2	TA2CCR2	16h
TA2 expansion 0	TA2EX0	20h
TA2 interrupt vector	TA2IV	2Eh

**Table 6-35. Real-Time Clock Registers (Base Address: 04A0h)**

REGISTER DESCRIPTION	REGISTER	OFFSET
RTC control 0	RTCCTL0	00h
RTC control 1	RTCCTL1	01h
RTC control 2	RTCCTL2	02h
RTC control 3	RTCCTL3	03h
RTC prescaler 0 control	RTCPS0CTL	08h
RTC prescaler 1 control	RTCPS1CTL	0Ah
RTC prescaler 0	RTCPS0	0Ch
RTC prescaler 1	RTCPS1	0Dh
RTC interrupt vector word	RTCIV	0Eh
RTC seconds/counter 1	RTCSEC/RTCNT1	10h
RTC minutes/counter 2	RTCMIN/RTCNT2	11h
RTC hours/counter 3	RTCHOUR/RTCNT3	12h
RTC day of week/counter 4	RTCADOW/RTCNT4	13h
RTC days	RTCDAW	14h
RTC month	RTCMON	15h

**Table 6-35. Real-Time Clock Registers (Base Address: 04A0h) (continued)**

REGISTER DESCRIPTION	REGISTER	OFFSET
RTC year low	RTCYEARL	16h
RTC year high	RTCYEARH	17h
RTC alarm minutes	RTCAMIN	18h
RTC alarm hours	RTCAHOUR	19h
RTC alarm day of week	RTCADOW	1Ah
RTC alarm days	RTCADAY	1Bh

**Table 6-36. 32-Bit Hardware Multiplier Registers (Base Address: 04C0h)**

REGISTER DESCRIPTION	REGISTER	OFFSET
16-bit operand 1 – multiply	MPY	00h
16-bit operand 1 – signed multiply	MPYS	02h
16-bit operand 1 – multiply accumulate	MAC	04h
16-bit operand 1 – signed multiply accumulate	MACS	06h
16-bit operand 2	OP2	08h
16 × 16 result low word	RESLO	0Ah
16 × 16 result high word	RESHI	0Ch
16 × 16 sum extension	SUMEXT	0Eh
32-bit operand 1 – multiply low word	MPY32L	10h
32-bit operand 1 – multiply high word	MPY32H	12h
32-bit operand 1 – signed multiply low word	MPYS32L	14h
32-bit operand 1 – signed multiply high word	MPYS32H	16h
32-bit operand 1 – multiply accumulate low word	MAC32L	18h
32-bit operand 1 – multiply accumulate high word	MAC32H	1Ah
32-bit operand 1 – signed multiply accumulate low word	MACS32L	1Ch
32-bit operand 1 – signed multiply accumulate high word	MACS32H	1Eh
32-bit operand 2 – low word	OP2L	20h
32-bit operand 2 – high word	OP2H	22h
32 × 32 result 0 – least significant word	RES0	24h
32 × 32 result 1	RES1	26h
32 × 32 result 2	RES2	28h
32 × 32 result 3 – most significant word	RES3	2Ah
MPY32 control 0	MPY32CTL0	2Ch

**Table 6-37. DMA Registers (Base Address DMA General Control: 0500h, DMA Channel 0: 0510h, DMA Channel 1: 0520h, DMA Channel 2: 0530h)**

REGISTER DESCRIPTION	REGISTER	OFFSET
DMA channel 0 control	DMA0CTL	00h
DMA channel 0 source address low	DMA0SAL	02h
DMA channel 0 source address high	DMA0SAH	04h
DMA channel 0 destination address low	DMA0DAL	06h
DMA channel 0 destination address high	DMA0DAH	08h
DMA channel 0 transfer size	DMA0SZ	0Ah
DMA channel 1 control	DMA1CTL	00h
DMA channel 1 source address low	DMA1SAL	02h
DMA channel 1 source address high	DMA1SAH	04h
DMA channel 1 destination address low	DMA1DAL	06h
DMA channel 1 destination address high	DMA1DAH	08h

**Table 6-37. DMA Registers (Base Address DMA General Control: 0500h,  
DMA Channel 0: 0510h, DMA Channel 1: 0520h, DMA Channel 2: 0530h) (continued)**

REGISTER DESCRIPTION	REGISTER	OFFSET
DMA channel 1 transfer size	DMA1SZ	0Ah
DMA channel 2 control	DMA2CTL	00h
DMA channel 2 source address low	DMA2SAL	02h
DMA channel 2 source address high	DMA2SAH	04h
DMA channel 2 destination address low	DMA2DAL	06h
DMA channel 2 destination address high	DMA2DAH	08h
DMA channel 2 transfer size	DMA2SZ	0Ah
DMA module control 0	DMACTL0	00h
DMA module control 1	DMACTL1	02h
DMA module control 2	DMACTL2	04h
DMA module control 3	DMACTL3	06h
DMA module control 4	DMACTL4	08h
DMA interrupt vector	DMAIV	0Eh

**Table 6-38. USCI\_A0 Registers (Base Address: 05C0h)**

REGISTER DESCRIPTION	REGISTER	OFFSET
USCI control 1	UCA0CTL1	00h
USCI control 0	UCA0CTL0	01h
USCI baud rate 0	UCA0BR0	06h
USCI baud rate 1	UCA0BR1	07h
USCI modulation control	UCA0MCTL	08h
USCI status	UCA0STAT	0Ah
USCI receive buffer	UCA0RXBUF	0Ch
USCI transmit buffer	UCA0TXBUF	0Eh
USCI LIN control	UCA0ABCTL	10h
USCI IrDA transmit control	UCA0IRTCTL	12h
USCI IrDA receive control	UCA0IRRCTL	13h
USCI interrupt enable	UCA0IE	1Ch
USCI interrupt flags	UCA0IFG	1Dh
USCI interrupt vector word	UCA0IV	1Eh

**Table 6-39. USCI\_B0 Registers (Base Address: 05E0h)**

REGISTER DESCRIPTION	REGISTER	OFFSET
USCI synchronous control 1	UCB0CTL1	00h
USCI synchronous control 0	UCB0CTL0	01h
USCI synchronous bit rate 0	UCB0BR0	06h
USCI synchronous bit rate 1	UCB0BR1	07h
USCI synchronous status	UCB0STAT	0Ah
USCI synchronous receive buffer	UCB0RXBUF	0Ch
USCI synchronous transmit buffer	UCB0TXBUF	0Eh
USCI I2C own address	UCB0I2COA	10h
USCI I2C slave address	UCB0I2CSA	12h
USCI interrupt enable	UCB0IE	1Ch
USCI interrupt flags	UCB0IFG	1Dh
USCI interrupt vector word	UCB0IV	1Eh

**Table 6-40. USCI\_A1 Registers (Base Address: 0600h)**

REGISTER DESCRIPTION	REGISTER	OFFSET
USCI control 1	UCA1CTL1	00h
USCI control 0	UCA1CTL0	01h
USCI baud rate 0	UCA1BR0	06h
USCI baud rate 1	UCA1BR1	07h
USCI modulation control	UCA1MCTL	08h
USCI status	UCA1STAT	0Ah
USCI receive buffer	UCA1RXBUF	0Ch
USCI transmit buffer	UCA1TXBUF	0Eh
USCI LIN control	UCA1ABCTL	10h
USCI IrDA transmit control	UCA1IRTCTL	12h
USCI IrDA receive control	UCA1IRRCTL	13h
USCI interrupt enable	UCA1IE	1Ch
USCI interrupt flags	UCA1IFG	1Dh
USCI interrupt vector word	UCA1IV	1Eh

**Table 6-41. USCI\_B1 Registers (Base Address: 0620h)**

REGISTER DESCRIPTION	REGISTER	OFFSET
USCI synchronous control 1	UCB1CTL1	00h
USCI synchronous control 0	UCB1CTL0	01h
USCI synchronous bit rate 0	UCB1BR0	06h
USCI synchronous bit rate 1	UCB1BR1	07h
USCI synchronous status	UCB1STAT	0Ah
USCI synchronous receive buffer	UCB1RXBUF	0Ch
USCI synchronous transmit buffer	UCB1TXBUF	0Eh
USCI I2C own address	UCB1I2COA	10h
USCI I2C slave address	UCB1I2CSA	12h
USCI interrupt enable	UCB1IE	1Ch
USCI interrupt flags	UCB1IFG	1Dh
USCI interrupt vector word	UCB1IV	1Eh

**Table 6-42. ADC10\_A Registers (Base Address: 0740h)**

REGISTER DESCRIPTION	REGISTER	OFFSET
ADC10_A control 0	ADC10CTL0	00h
ADC10_A control 1	ADC10CTL1	02h
ADC10_A control 2	ADC10CTL2	04h
ADC10_A window comparator low threshold	ADC10LO	06h
ADC10_A window comparator high threshold	ADC10HI	08h
ADC10_A memory control 0	ADC10MCTL0	0Ah
ADC10_A conversion memory	ADC10MEM0	12h
ADC10_A interrupt enable	ADC10IE	1Ah
ADC10_A interrupt flags	ADC10IGH	1Ch
ADC10_A interrupt vector word	ADC10IV	1Eh

**Table 6-43. Comparator\_B Registers (Base Address: 08C0h)**

REGISTER DESCRIPTION	REGISTER	OFFSET
Comp_B control 0	CBCTL0	00h
Comp_B control 1	CBCTL1	02h
Comp_B control 2	CBCTL2	04h
Comp_B control 3	CBCTL3	06h
Comp_B interrupt	CBINT	0Ch
Comp_B interrupt vector word	CBIV	0Eh

## 6.10 Input/Output Diagrams

### 6.10.1 Port P1 (P1.0 to P1.7) Input/Output With Schmitt Trigger

Figure 6-2 shows the port diagram. Table 6-44 summarizes the selection of the port function.

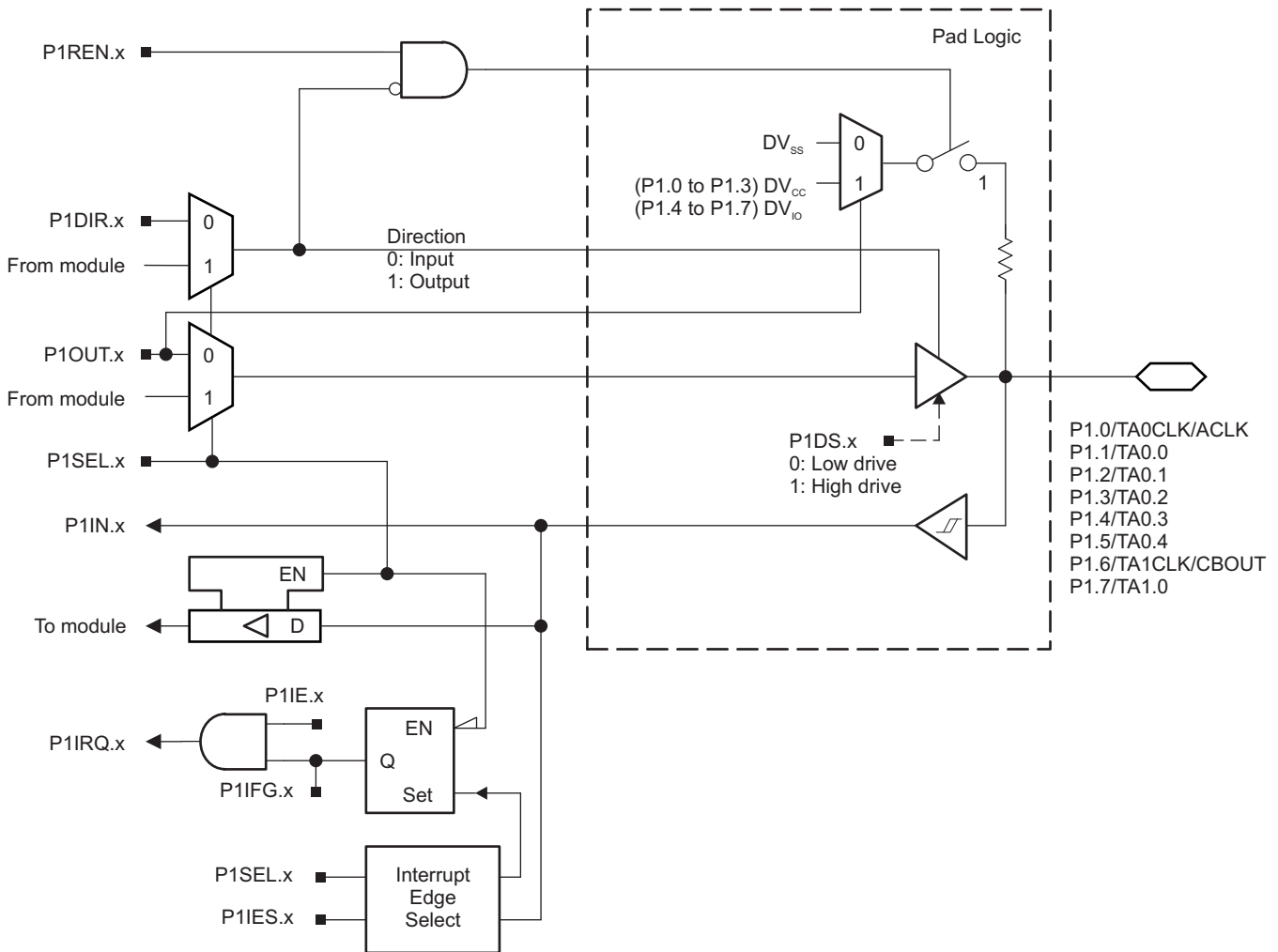

Figure 6-2. Port P1 (P1.0 to P1.7) Diagram

**Table 6-44. Port P1 (P1.0 to P1.7) Pin Functions**

PIN NAME (P1.x)	x	FUNCTION	CONTROL BITS OR SIGNALS	
			P1DIR.x	P1SEL.x
P1.0/TA0CLK/ACLK	0	P1.0 (I/O)	I: 0; O: 1	0
		TA0CLK	0	1
		ACLK	1	1
P1.1/TA0.0	1	P1.1 (I/O)	I: 0; O: 1	0
		TA0.CCI0A	0	1
		TA0.0	1	1
P1.2/TA0.1	2	P1.2 (I/O)	I: 0; O: 1	0
		TA0.CCI1A	0	1
		TA0.1	1	1
P1.3/TA0.2	3	P1.3 (I/O)	I: 0; O: 1	0
		TA0.CCI2A	0	1
		TA0.2	1	1
P1.4/TA0.3	4	P1.4 (I/O)	I: 0; O: 1	0
		TA0.CCI3A	0	1
		TA0.3	1	1
P1.5/TA0.4	5	P1.5 (I/O)	I: 0; O: 1	0
		TA0.CCI4A	0	1
		TA0.4	1	1
P1.6/TA1CLK/CBOUT	6	P1.6 (I/O)	I: 0; O: 1	0
		TA1CLK	0	1
		CBOUT comparator B	1	1
P1.7/TA1.0	7	P1.7 (I/O)	I: 0; O: 1	0
		TA1.CCI0A	0	1
		TA1.0	1	1



**Table 6-45. Port P2 (P2.0 to P2.7) Pin Functions**

PIN NAME (P2.x)	x	FUNCTION	CONTROL BITS OR SIGNALS <sup>(1)</sup>	
			P2DIR.x	P2SEL.x
P2.0/TA1.1 <sup>(2)</sup>	0	P2.0 (I/O)	I: 0; O: 1	0
		TA1.CCI1A	0	1
		TA1.1	1	1
P2.1/TA1.2 <sup>(2)</sup>	1	P2.1 (I/O)	I: 0; O: 1	0
		TA1.CCI2A	0	1
		TA1.2	1	1
P2.2/TA2CLK/SMCLK <sup>(2)</sup>	2	P2.2 (I/O)	I: 0; O: 1	0
		TA2CLK	0	1
		SMCLK	1	1
P2.3/TA2.0 <sup>(2)</sup>	3	P2.3 (I/O)	I: 0; O: 1	0
		TA2.CCI0A	0	1
		TA2.0	1	1
P2.4/TA2.1 <sup>(2)</sup>	4	P2.4 (I/O)	I: 0; O: 1	0
		TA2.CCI1A	0	1
		TA2.1	1	1
P2.5/TA2.2 <sup>(2)</sup>	5	P2.5 (I/O)	I: 0; O: 1	0
		TA2.CCI2A	0	1
		TA2.2	1	1
P2.6/RTCCLK/DMAE0 <sup>(2)</sup>	6	P2.6 (I/O)	I: 0; O: 1	0
		DMAE0	0	1
		RTCCLK	1	1
P2.7/UCB0STE/UCA0CLK	7	P2.7 (I/O)	I: 0; O: 1	0
		UCB0STE/UCA0CLK <sup>(3) (4)</sup>	X	1

(1) X = Don't care

(2) Not available on RGZ package types.

(3) The pin direction is controlled by the USCI module.

(4) UCA0CLK function takes precedence over UCB0STE function. If the pin is required as UCA0CLK input or output, USCI\_B0 is forced to 3-wire SPI mode if 4-wire SPI mode is selected.

### 6.10.3 Port P3 (P3.0 to P3.4) Input/Output With Schmitt Trigger

Figure 6-4 shows the port diagram. Table 6-46 summarizes the selection of the port function.

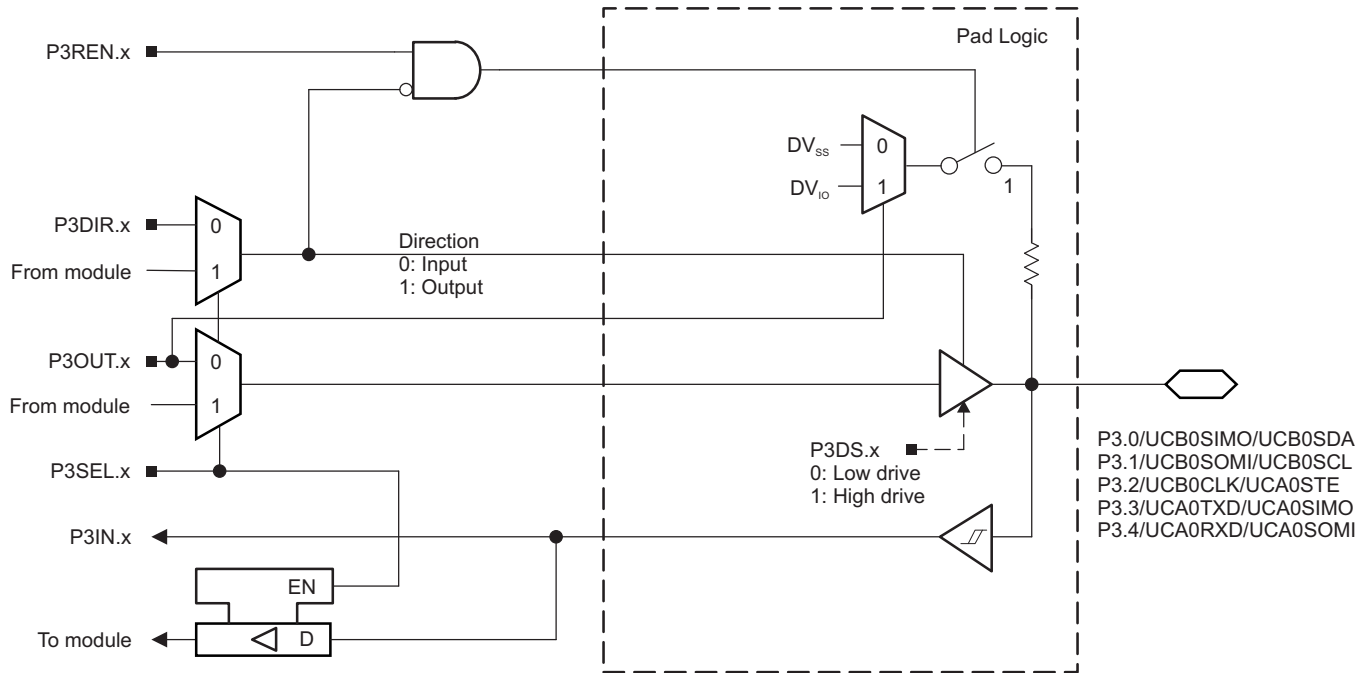

Figure 6-4. Port P3 (P3.0 to P3.4) Diagram

Table 6-46. Port P3 (P3.0 to P3.4) Pin Functions

PIN NAME (P3.x)	x	FUNCTION	CONTROL BITS OR SIGNALS <sup>(1)</sup>	
			P3DIR.x	P3SEL.x
P3.0/UCB0SIMO/UCB0SDA	0	P3.0 (I/O)	I: 0; O: 1	0
		UCB0SIMO/UCB0SDA <sup>(2) (3)</sup>	X	1
P3.1/UCB0SOMI/UCB0SCL	1	P3.1 (I/O)	I: 0; O: 1	0
		UCB0SOMI/UCB0SCL <sup>(2) (3)</sup>	X	1
P3.2/UCB0CLK/UCA0STE	2	P3.2 (I/O)	I: 0; O: 1	0
		UCB0CLK/UCA0STE <sup>(2) (4)</sup>	X	1
P3.3/UCA0TXD/UCA0SIMO	3	P3.3 (I/O)	I: 0; O: 1	0
		UCA0TXD/UCA0SIMO <sup>(2)</sup>	X	1
P3.4/UCA0RXD/UCA0SOMI	4	P3.4 (I/O)	I: 0; O: 1	0
		UCA0RXD/UCA0SOMI <sup>(2)</sup>	X	1

(1) X = Don't care

(2) The pin direction is controlled by the USCI module.

(3) If the I2C functionality is selected, the output drives only the logical 0 to V<sub>SS</sub> level.

(4) UCB0CLK function takes precedence over UCA0STE function. If the pin is required as UCB0CLK input or output, USCI\_A0 is forced to 3-wire SPI mode if 4-wire SPI mode is selected.

### 6.10.4 Port P4 (P4.0 to P4.7) Input/Output With Schmitt Trigger

Figure 6-5 shows the port diagram. Table 6-47 summarizes the selection of the port function.

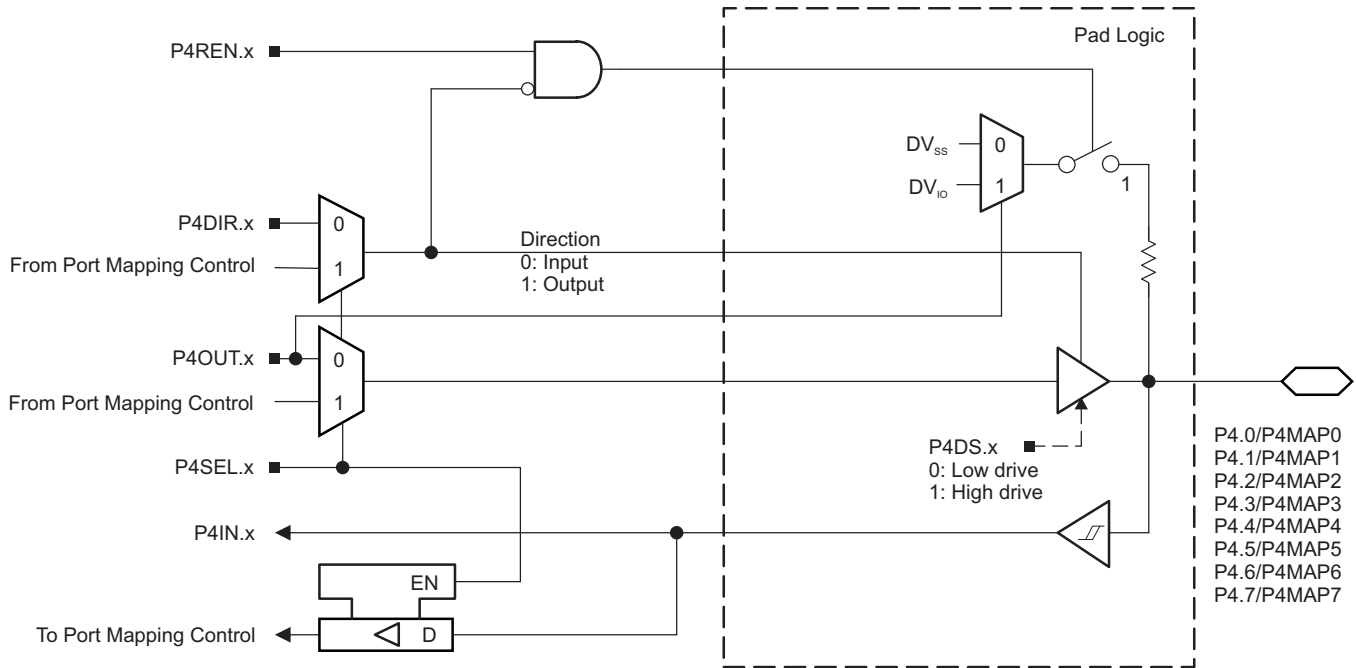

Figure 6-5. Port P4 (P4.0 to P4.7) Diagram

Table 6-47. Port P4 (P4.0 to P4.7) Pin Functions

PIN NAME (P4.x)	x	FUNCTION	CONTROL BITS OR SIGNALS <sup>(1)</sup>		
			P4DIR.x <sup>(2)</sup>	P4SEL.x	P4MAPx
P4.0/P4MAP0	0	P4.0 (I/O)	I: 0; O: 1	0	X
		Mapped secondary digital function	X	1	≤ 30
P4.1/P4MAP1	1	P4.1 (I/O)	I: 0; O: 1	0	X
		Mapped secondary digital function	X	1	≤ 30
P4.2/P4MAP2	2	P4.2 (I/O)	I: 0; O: 1	0	X
		Mapped secondary digital function	X	1	≤ 30
P4.3/P4MAP3	3	P4.3 (I/O)	I: 0; O: 1	0	X
		Mapped secondary digital function	X	1	≤ 30
P4.4/P4MAP4	4	P4.4 (I/O)	I: 0; O: 1	0	X
		Mapped secondary digital function	X	1	≤ 30
P4.5/P4MAP5	5	P4.5 (I/O)	I: 0; O: 1	0	X
		Mapped secondary digital function	X	1	≤ 30
P4.6/P4MAP6	6	P4.6 (I/O)	I: 0; O: 1	0	X
		Mapped secondary digital function	X	1	≤ 30
P4.7/P4MAP7 <sup>(3)</sup>	7	P4.7 (I/O)	I: 0; O: 1	0	X
		Mapped secondary digital function	X	1	≤ 30

(1) X = Don't care

(2) The direction of some mapped secondary functions are controlled directly by the module. See Table 6-7 for specific direction control information of mapped secondary functions.

(3) Not available on RGZ package types.

### 6.10.5 Port P5 (P5.0 and P5.1) Input/Output With Schmitt Trigger

Figure 6-6 shows the port diagram. Table 6-48 summarizes the selection of the port function.

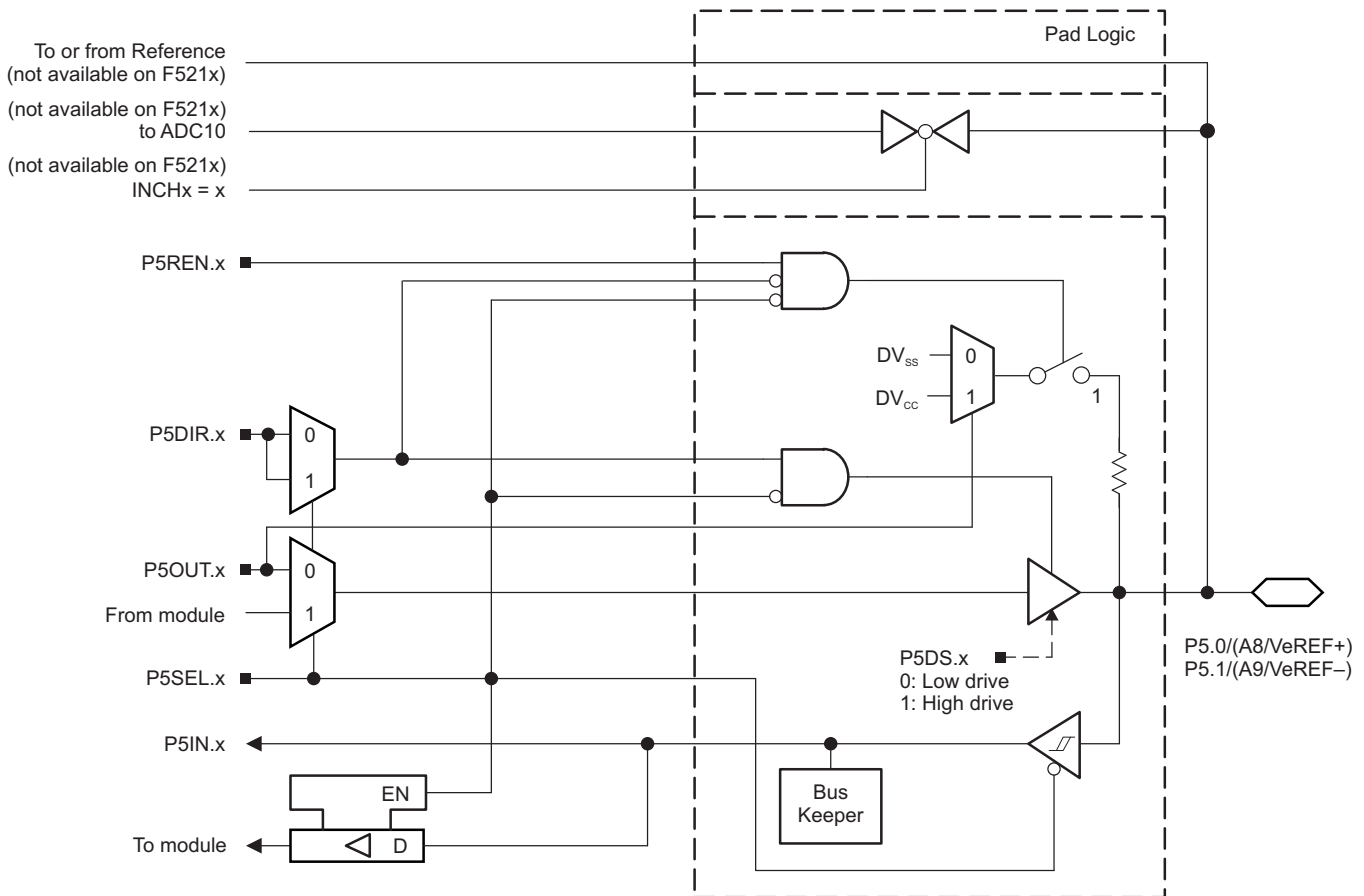

Figure 6-6. Port P5 (P5.0 and P5.1) Diagram

Table 6-48. Port P5 (P5.0 and P5.1) Pin Functions

PIN NAME (P5.x)	x	FUNCTION	CONTROL BITS OR SIGNALS <sup>(1)</sup>		
			P5DIR.x	P5SEL.x	REFOUT <sup>(2)</sup>
P5.0/A8/VeREF+	0	P5.0 (I/O) <sup>(3)</sup>	I: 0; O: 1	0	X
		A8/VeREF+ <sup>(4)</sup>	X	1	0
P5.1/A9/VeREF-	1	P5.1 (I/O) <sup>(3)</sup>	I: 0; O: 1	0	X
		A9/VeREF- <sup>(5)</sup>	X	1	0

(1) X = Don't care

(2) REFOUT resides in the REF module.

(3) Default condition

(4) Setting the P5SEL.0 bit disables the output driver and the input Schmitt trigger to prevent parasitic cross currents when applying analog signals. An external voltage can be applied to VeREF+ and used as the reference for the ADC10\_A. Channel A8, when selected with the INCHx bits, is connected to the VeREF+ pin.

(5) Setting the P5SEL.1 bit disables the output driver and the input Schmitt trigger to prevent parasitic cross currents when applying analog signals. An external voltage can be applied to VeREF- and used as the reference for the ADC10\_A. Channel A9, when selected with the INCHx bits, is connected to the VeREF- pin.

### 6.10.6 Port P5 (P5.2) Input/Output With Schmitt Trigger

Figure 6-7 shows the port diagram. Table 6-49 summarizes the selection of the port function.

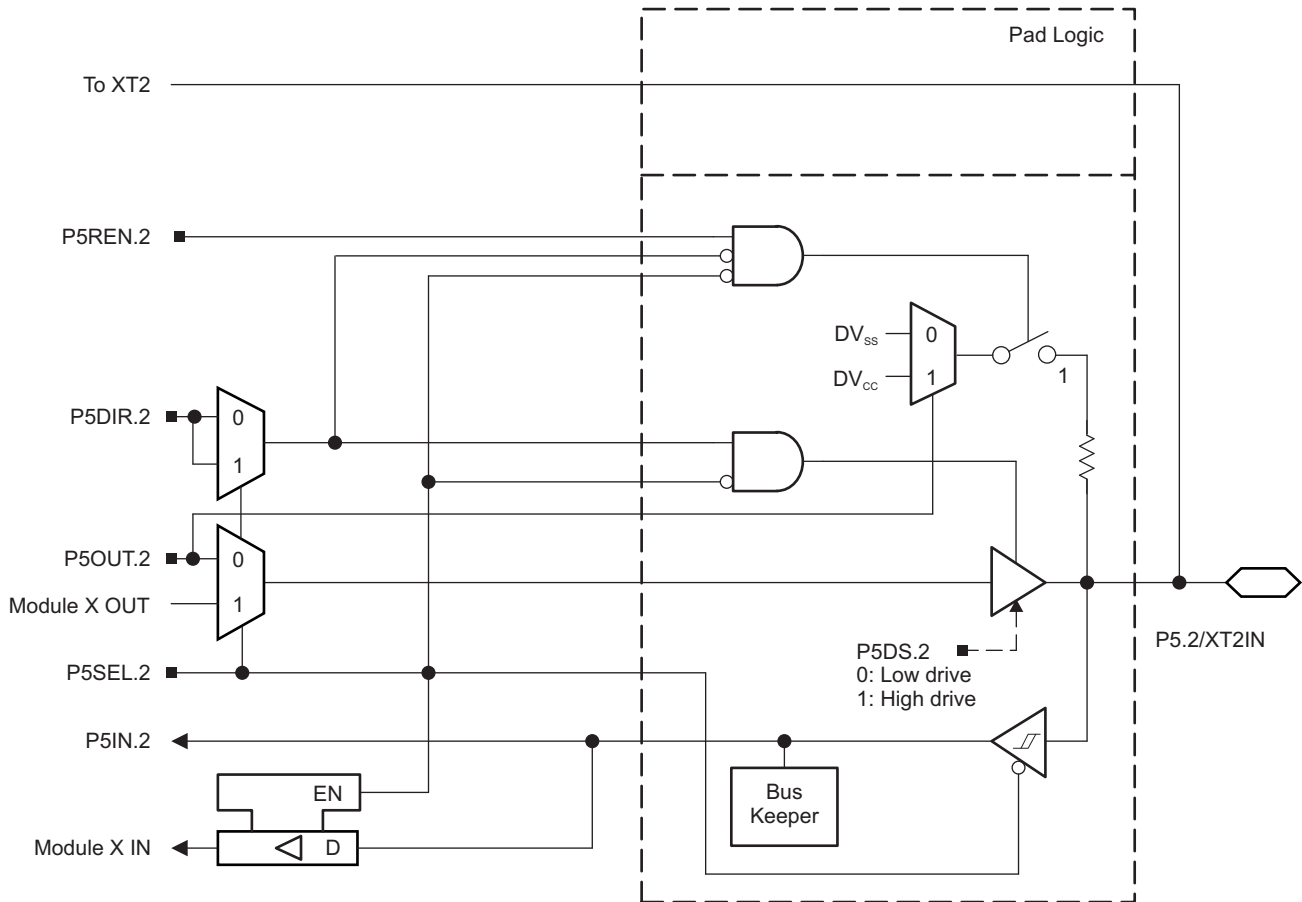

Figure 6-7. Port P5 (P5.2) Diagram

### 6.10.7 Port P5 (P5.3) Input/Output With Schmitt Trigger

Figure 6-8 shows the port diagram. Table 6-49 summarizes the selection of the port function.

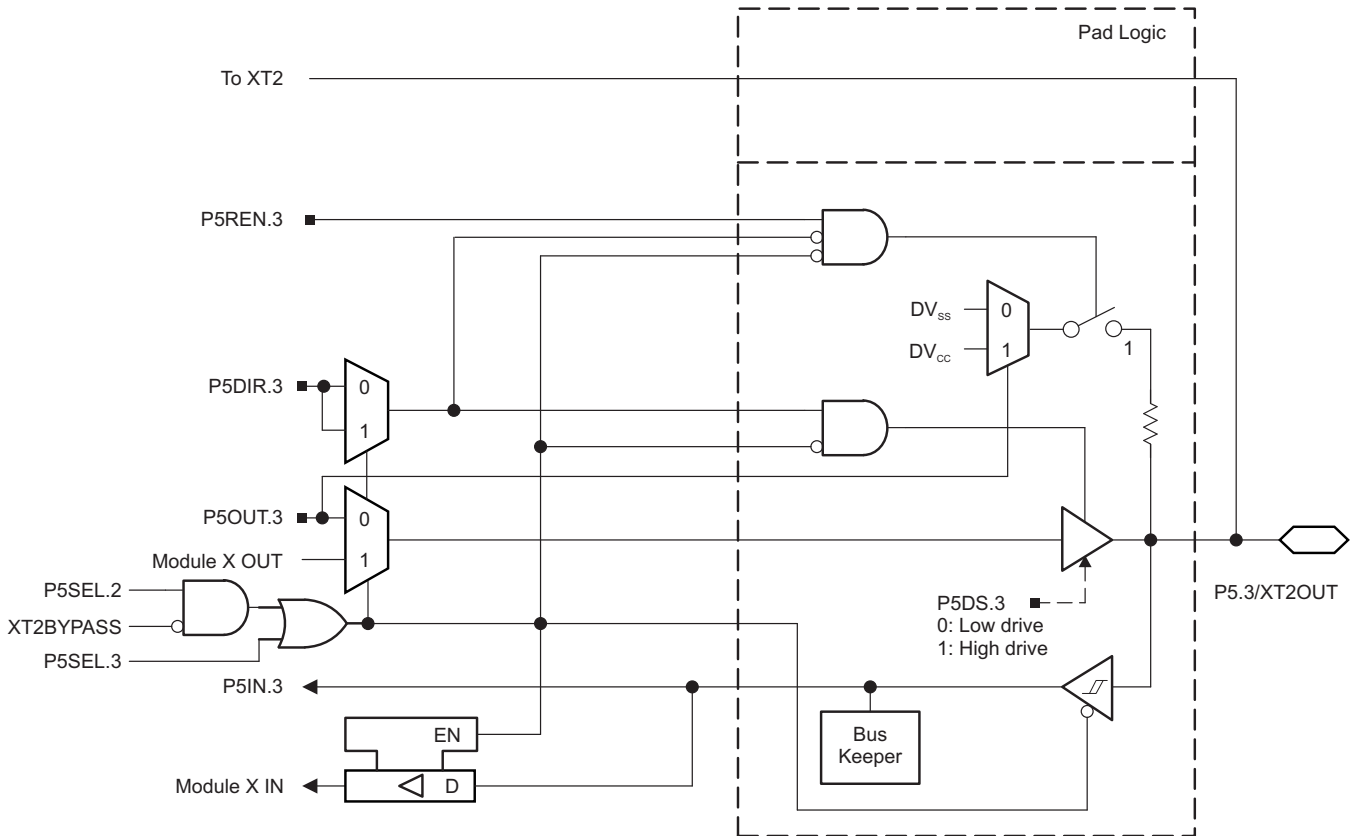

Figure 6-8. Port P5 (P5.3) Diagram

Table 6-49. Port P5 (P5.2 and P5.3) Pin Functions

PIN NAME (P5.x)	x	FUNCTION	CONTROL BITS OR SIGNALS <sup>(1)</sup>			
			P5DIR.x	P5SEL.2	P5SEL.3	XT2BYPASS
P5.2/XT2IN	2	P5.2 (I/O)	I: 0; O: 1	0	X	X
		XT2IN crystal mode <sup>(2)</sup>	X	1	X	0
		XT2IN bypass mode <sup>(2)</sup>	X	1	X	1
P5.3/XT2OUT	3	P5.3 (I/O)	I: 0; O: 1	0	0	X
		XT2OUT crystal mode <sup>(3)</sup>	X	1	X	0
		P5.3 (I/O) <sup>(3)</sup>	X	1	0	1

- (1) X = Don't care  
(2) Setting P5SEL.2 causes the general-purpose I/O to be disabled. Pending the setting of XT2BYPASS, P5.2 is configured for crystal mode or bypass mode.  
(3) Setting P5SEL.2 causes the general-purpose I/O to be disabled in crystal mode. When using bypass mode, P5.3 can be used as general-purpose I/O.

### 6.10.8 Port P5 (P5.4 and P5.5) Input/Output With Schmitt Trigger

Figure 6-9 and Figure 6-10 show the port diagrams. Table 6-50 summarizes the selection of the port function.

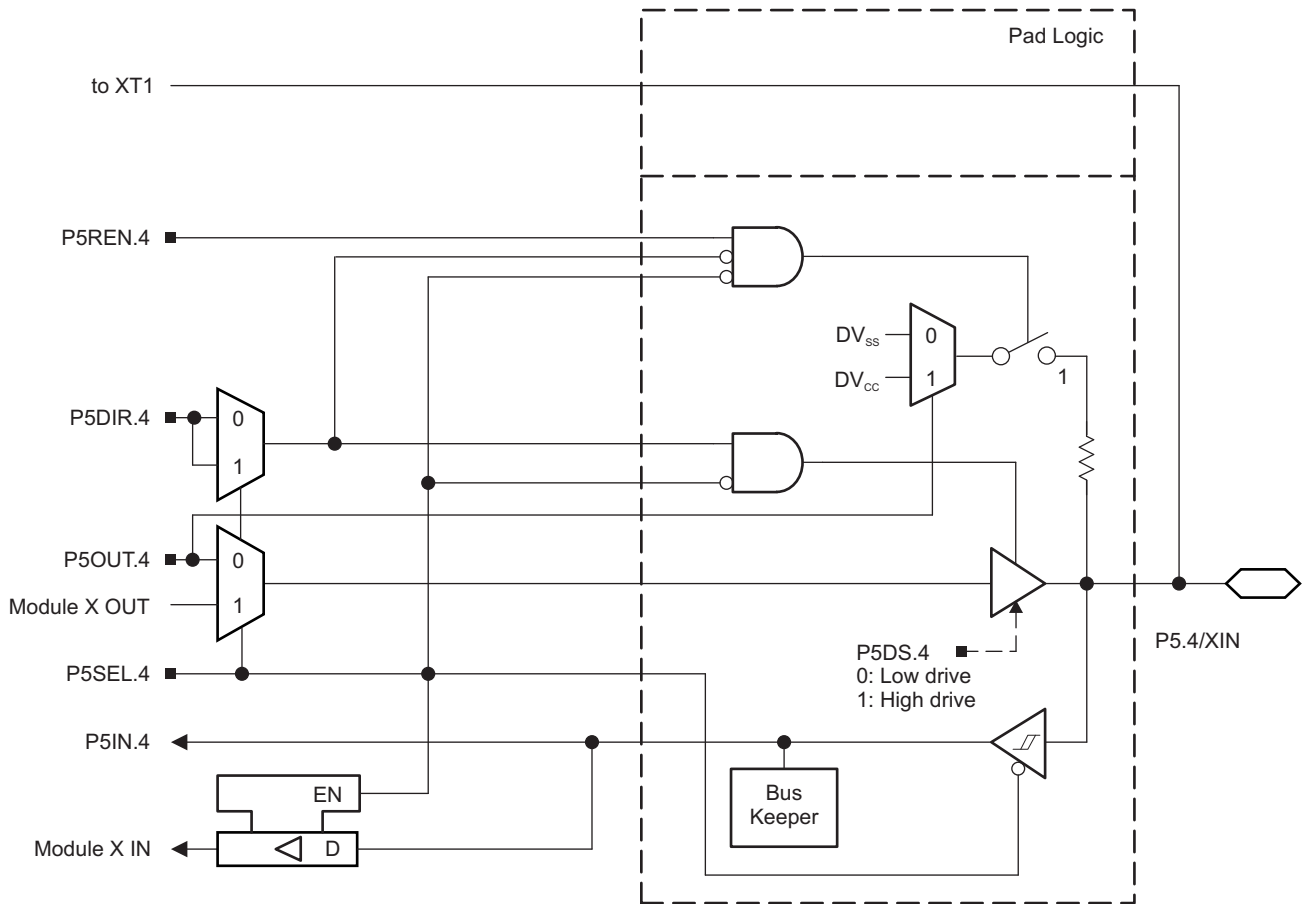

Figure 6-9. Port P5 (P5.4) Diagram

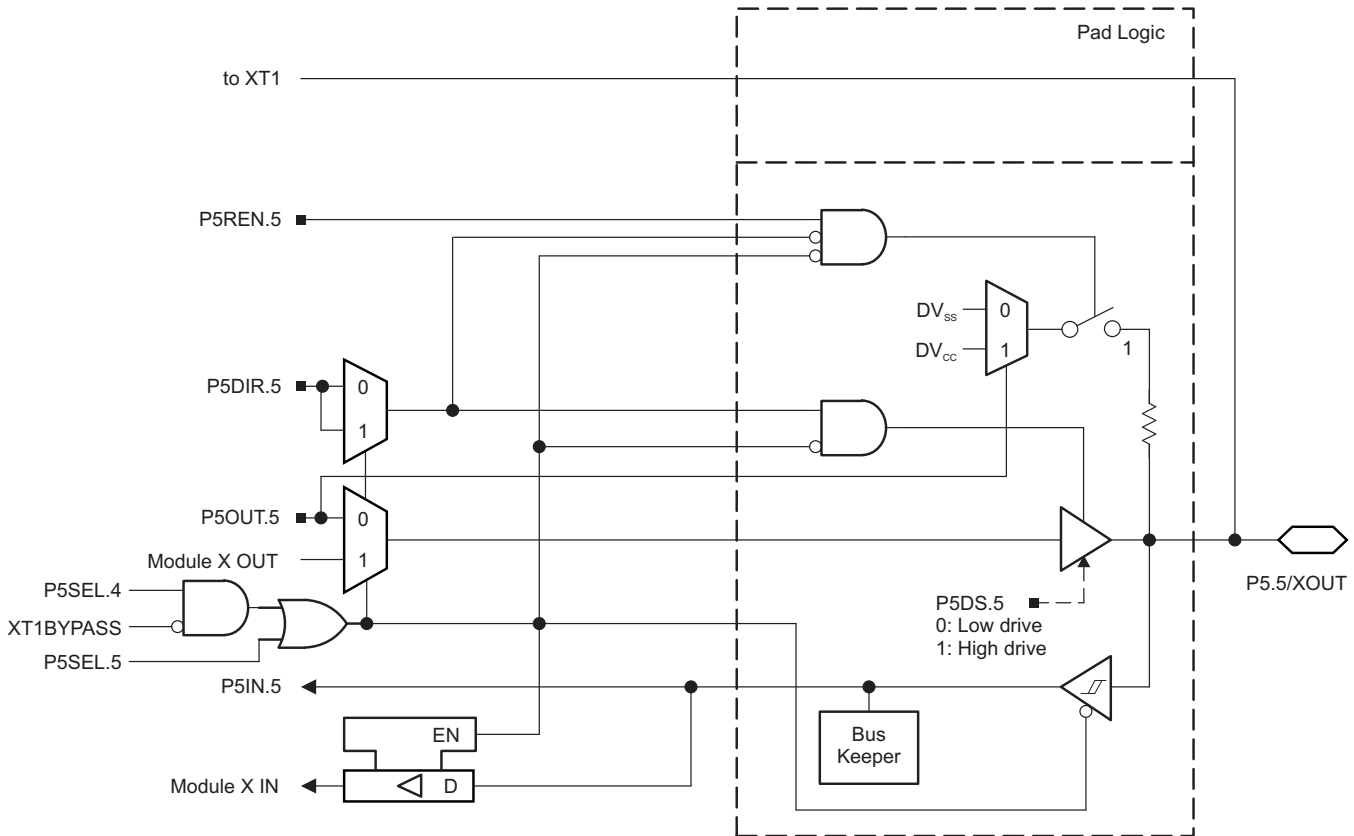

Figure 6-10. Port P5 (P5.5) Diagram

Table 6-50. Port P5 (P5.4 and P5.5) Pin Functions

PIN NAME (P5.x)	x	FUNCTION	CONTROL BITS OR SIGNALS <sup>(1)</sup>			
			P5DIR.x	P5SEL.4	P5SEL.5	XT1BYPASS
P5.4/XIN	4	P5.4 (I/O)	I: 0; O: 1	0	X	X
		XIN crystal mode <sup>(2)</sup>	X	1	X	0
		XIN bypass mode <sup>(2)</sup>	X	1	X	1
P5.5/XOUT	5	P5.5 (I/O)	I: 0; O: 1	0	0	X
		XOUT crystal mode <sup>(3)</sup>	X	1	X	0
		P5.5 (I/O) <sup>(3)</sup>	X	1	0	1

- (1) X = Don't care  
(2) Setting P5SEL.4 causes the general-purpose I/O to be disabled. Pending the setting of XT1BYPASS, P5.4 is configured for crystal mode or bypass mode.  
(3) Setting P5SEL.4 causes the general-purpose I/O to be disabled in crystal mode. When using bypass mode, P5.5 can be used as general-purpose I/O.

### 6.10.9 Port P6 (P6.0 to P6.7) Input/Output With Schmitt Trigger

Figure 6-11 shows the port diagram. Table 6-51 summarizes the selection of the port function.

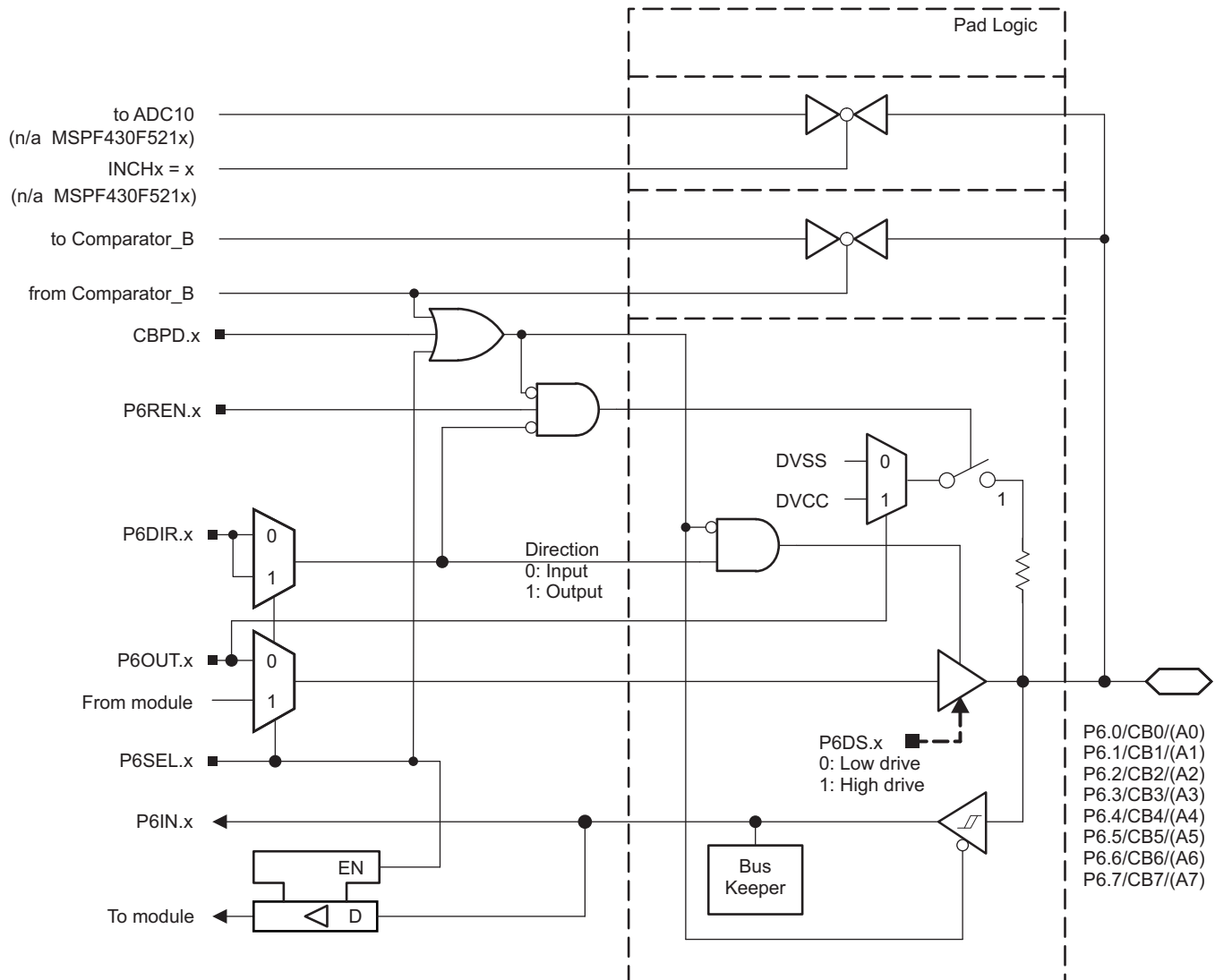

Figure 6-11. Port P6 (P6.0 to P6.7) Diagram

**Table 6-51. Port P6 (P6.0 to P6.7) Pin Functions**

PIN NAME (P6.x)	x	FUNCTION	CONTROL BITS OR SIGNALS		
			P6DIR.x	P6SEL.x	CBPD
P6.0/CB0/(A0)	0	P6.0 (I/O)	I: 0; O: 1	0	0
		A0	X	1	X
		CB0 <sup>(1)</sup>	X	X	1
P6.1/CB1/(A1)	1	P6.1 (I/O)	I: 0; O: 1	0	0
		A1	X	1	X
		CB1 <sup>(1)</sup>	X	X	1
P6.2/CB2/(A2)	2	P6.2 (I/O)	I: 0; O: 1	0	0
		A2	X	1	X
		CB2 <sup>(1)</sup>	X	X	1
P6.3/CB3/(A3)	3	P6.3 (I/O)	I: 0; O: 1	0	0
		A3	X	1	X
		CB3 <sup>(1)</sup>	X	X	1
P6.4/CB4/(A4)	4	P6.4 (I/O)	I: 0; O: 1	0	0
		A4	X	1	X
		CB4 <sup>(1)</sup>	X	X	1
P6.5/CB5/(A5)	5	P6.5 (I/O)	I: 0; O: 1	0	0
		A5	X	1	X
		CB5 <sup>(1)</sup>	X	X	1
P6.6/CB6/(A6) <sup>(2)</sup>	6	P6.6 (I/O)	I: 0; O: 1	0	0
		A6	X	1	X
		CB6 <sup>(1)</sup>	X	X	1
P6.7/CB7/(A7) <sup>(2)</sup>	7	P6.7 (I/O)	I: 0; O: 1	0	0
		A7	X	1	X
		CB7 <sup>(1)</sup>	X	X	1

(1) Setting the CBPD.x bit disables the output driver and the input Schmitt trigger to prevent parasitic cross currents when applying analog signals. Selecting the CBx input pin to the comparator multiplexer with the CBx bits automatically disables output driver and input buffer for that pin, regardless of the state of the associated CBPD.x bit.

(2) Not available on RGZ package types.





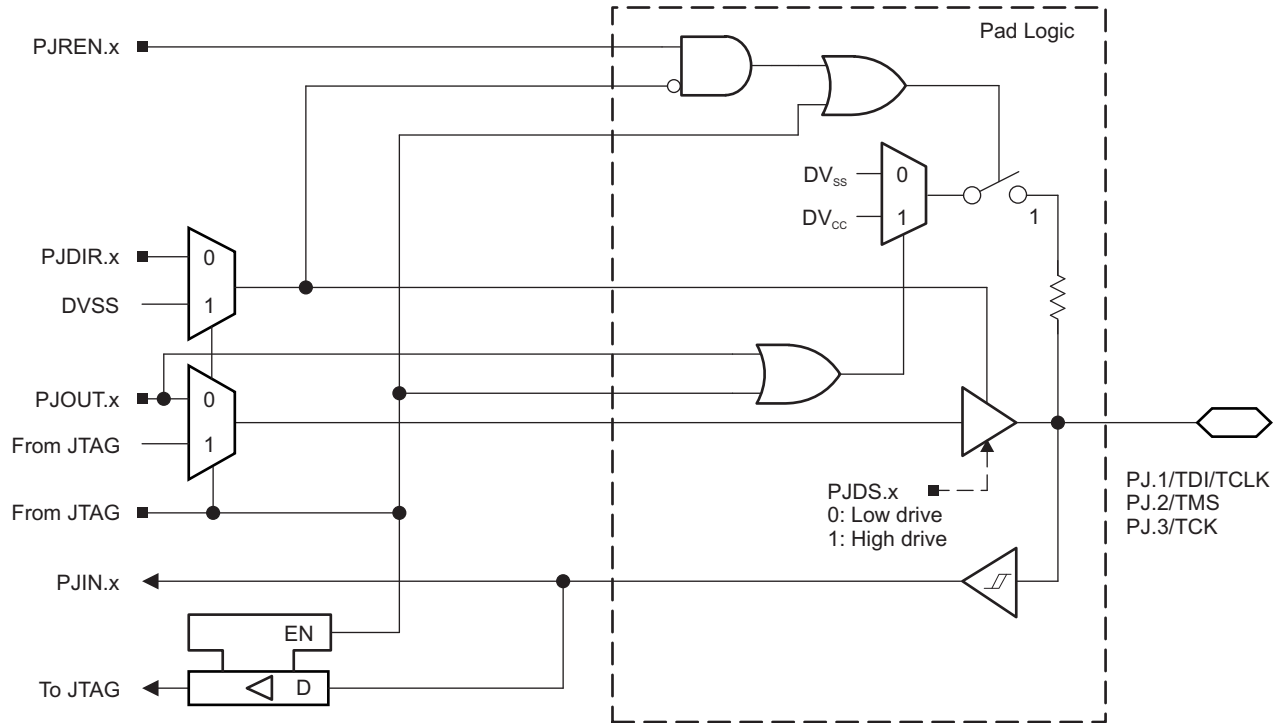

Figure 6-14. Port PJ (PJ.1 to PJ.3) Diagram

**Table 6-53. Port PJ (PJ.0 to PJ.3) Pin Functions**

PIN NAME (PJ.x)	x	FUNCTION	CONTROL BITS OR SIGNALS <sup>(1)</sup>
			PJDIR.x
PJ.0/TDO	0	PJ.0 (I/O) <sup>(2)</sup>	I: 0; O: 1
		TDO <sup>(3)</sup>	X
PJ.1/TDI/TCLK	1	PJ.1 (I/O) <sup>(2)</sup>	I: 0; O: 1
		TDI/TCLK <sup>(3) (4)</sup>	X
PJ.2/TMS	2	PJ.2 (I/O) <sup>(2)</sup>	I: 0; O: 1
		TMS <sup>(3) (4)</sup>	X
PJ.3/TCK	3	PJ.3 (I/O) <sup>(2)</sup>	I: 0; O: 1
		TCK <sup>(3) (4)</sup>	X

- (1) X = Don't care
- (2) Default condition
- (3) The pin direction is controlled by the JTAG module.
- (4) In JTAG mode, pullups are activated automatically on TMS, TCK, and TDI/TCLK. PJREN.x are do not care.

## 6.11 Device Descriptors

Table 6-54 and Table 6-55 list the contents of the device descriptor tag-length-value (TLV) structure for each device type.

**Table 6-54. MSP430F522x Device Descriptor Table<sup>(1)</sup>**

DESCRIPTION	ADDRESS	SIZE (BYTES)	VALUE				
			F5229	F5227	F5224	F5222	
Info Block	Info length	01A00h	1	06h	06h	06h	06h
	CRC length	01A01h	1	06h	06h	06h	06h
	CRC value	01A02h	2	Per unit	Per unit	Per unit	Per unit
	Device ID	01A04h	1	51h	4Fh	4Ch	4Ah
	Device ID	01A05h	1	81h	81h	81h	81h
	Hardware revision	01A06h	1	Per unit	Per unit	Per unit	Per unit
	Firmware revision	01A07h	1	Per unit	Per unit	Per unit	Per unit
Die Record	Die record tag	01A08h	1	08h	08h	08h	08h
	Die record length	01A09h	1	0Ah	0Ah	0Ah	0Ah
	Lot/wafer ID	01A0Ah	4	Per unit	Per unit	Per unit	Per unit
	Die X position	01A0Eh	2	Per unit	Per unit	Per unit	Per unit
	Die Y position	01A10h	2	Per unit	Per unit	Per unit	Per unit
	Test results	01A12h	2	Per unit	Per unit	Per unit	Per unit
ADC10 Calibration	ADC10 calibration tag	01A14h	1	13h	13h	13h	13h
	ADC10 calibration length	01A15h	1	10h	10h	10h	10h
	ADC gain factor	01A16h	2	Per unit	Per unit	Per unit	Per unit
	ADC offset	01A18h	2	Per unit	Per unit	Per unit	Per unit
	ADC 1.5-V reference Temperature sensor 30°C	01A1Ah	2	Per unit	Per unit	Per unit	Per unit
	ADC 1.5-V reference Temperature sensor 85°C	01A1Ch	2	Per unit	Per unit	Per unit	Per unit
	ADC 2.0-V reference Temperature sensor 30°C	01A1Eh	2	Per unit	Per unit	Per unit	Per unit
	ADC 2.0-V reference Temperature sensor 85°C	01A20h	2	Per unit	Per unit	Per unit	Per unit
	ADC 2.5-V reference Temperature sensor 30°C	01A22h	2	Per unit	Per unit	Per unit	Per unit
	ADC 2.5-V reference Temperature sensor 85°C	01A24h	2	Per unit	Per unit	Per unit	Per unit
REF Calibration	REF calibration tag	01A26h	1	12h	12h	12h	12h
	REF calibration length	01A27h	1	06h	06h	06h	06h
	REF 1.5-V reference factor	01A28h	2	Per unit	Per unit	Per unit	Per unit
	REF 2.0-V reference factor	01A2Ah	2	Per unit	Per unit	Per unit	Per unit
	REF 2.5-V reference factor	01A2Ch	2	Per unit	Per unit	Per unit	Per unit

(1) NA = Not applicable

**Table 6-54. MSP430F522x Device Descriptor Table<sup>(1)</sup> (continued)**

DESCRIPTION	ADDRESS	SIZE (BYTES)	VALUE			
			F5229	F5227	F5224	F5222
Peripheral descriptor tag	01A2Eh	1	02h	02h	02h	02h
Peripheral descriptor length	01A2Fh	1	5Fh	5Fh	5Dh	5Dh
Memory 1		2	08h 8Ah	08h 8Ah	08h 8Ah	08h 8Ah
Memory 2		2	0Ch 86h	0Ch 86h	0Ch 86h	0Ch 86h
Memory 3		2	12h 2Eh	12h 2Eh	12h 2Eh	12h 2Eh
Memory 4		2	22h 96h	22h 94h	22h 96h	22h 94h
Memory 5		2	N/A	N/A	N/A	N/A
Memory 6		1/2	N/A	N/A	N/A	N/A
Delimiter		1	00h	00h	00h	00h
Peripheral count		1	20h	20h	1Fh	1Fh
MSP430CPUXV2		2	00h 23h	00h 23h	00h 23h	00h 23h
JTAG		2	00h 09h	00h 09h	00h 09h	00h 09h
SBW		2	00h 0Fh	00h 0Fh	00h 0Fh	00h 0Fh
EEM-S		2	00h 03h	00h 03h	00h 03h	00h 05h
TI BSL		2	00h FCh	00h FCh	00h FCh	00h FCh
SFR		2	10h 41h	10h 41h	10h 41h	10h 41h
PMM		2	02h 30h	02h 30h	02h 30h	02h 30h
FCTL		2	02h 38h	02h 38h	02h 38h	02h 38h
CRC16		2	01h 3Ch	01h 3Ch	01h 3Ch	01h 3Ch
CRC16_RB		2	00h 3Dh	00h 3Dh	00h 3Dh	00h 3Dh
RAMCTL		2	00h 44h	00h 44h	00h 44h	00h 44h
WDT_A		2	00h 40h	00h 40h	00h 40h	00h 40h
UCS		2	01h 48h	01h 48h	01h 48h	01h 48h
SYS		2	02h 42h	02h 42h	02h 42h	02h 42h
REF		2	03h A0h	03h A0h	03h A0h	03h A0h
Port mapping		2	01h 10h	01h 10h	01h 10h	01h 10h
Port 1/2		2	04h 51h	04h 51h	04h 51h	04h 51h
Port 3/4		2	02h 52h	02h 52h	02h 52h	02h 52h
Port 5/6		2	02h 53h	02h 53h	02h 53h	02h 53h

Peripheral  
Descriptor

**Table 6-54. MSP430F522x Device Descriptor Table<sup>(1)</sup> (continued)**

DESCRIPTION	ADDRESS	SIZE (BYTES)	VALUE				
			F5229	F5227	F5224	F5222	
Peripheral Descriptor (continued)	Port 7/8		2	02h 54h	02h 54h	N/A	N/A
	JTAG		2	0Ch 5Fh	0Ch 5Fh	0Eh 5Fh	0Eh 5Fh
	TA0		2	02h 62h	02h 62h	02h 62h	02h 62h
	TA1		2	04h 61h	04h 61h	04h 61h	04h 61h
	TB0		2	04h 67h	04h 67h	04h 67h	04h 67h
	TA2		2	04h 61h	04h 61h	04h 61h	04h 61h
	RTC		2	0Ah 68h	0Ah 68h	0Ah 68h	0Ah 68h
	MPY32		2	02h 85h	02h 85h	02h 85h	02h 85h
	DMA-3		2	04h 47h	04h 47h	04h 47h	04h 47h
	USCI_A/B		2	0Ch 90h	0Ch 90h	0Ch 90h	0Ch 90h
	USCI_A/B		2	04h 90h	04h 90h	04h 90h	04h 90h
	ADC10_A		2	14h D3h	14h D3h	14h D3h	14h D3h
	COMP_B		2	18h A8h	18h A8h	18h A8h	18h A8h
	Interrupts	COMP_B		1	A8h	A8h	A8h
TB0.CCIFG0			1	64h	64h	64h	64h
TB0.CCIFG1..6			1	65h	65h	65h	65h
WDTIFG			1	40h	40h	40h	40h
USCI_A0			1	90h	90h	90h	90h
USCI_B0			1	91h	91h	91h	91h
ADC10_A			1	D0h	D0h	D0h	D0h
TA0.CCIFG0			1	60h	60h	60h	60h
TA0.CCIFG1..4			1	61h	61h	61h	61h
Reserved			1	01h	01h	01h	01h
DMA			1	46h	46h	46h	46h
TA1.CCIFG0			1	62h	62h	62h	62h
TA1.CCIFG1..2			1	63h	63h	63h	63h
P1			1	50h	50h	50h	50h
USCI_A1			1	92h	92h	92h	92h
USCI_B1			1	93h	93h	93h	93h
TA1.CCIFG0			1	66h	66h	66h	66h
TA1.CCIFG1..2			1	67h	67h	67h	67h
P2			1	51h	51h	51h	51h
RTC_A			1	68h	68h	68h	68h
Delimiter		1	00h	00h	00h	00h	

**Table 6-55. MSP430F521x Device Descriptor Table<sup>(1)</sup>**

DESCRIPTION	ADDRESS	SIZE (BYTES)	VALUE				
			F5219	F5217	F5214	F5212	
Info Block	Info length	01A00h	1	06h	06h	06h	06h
	CRC length	01A01h	1	06h	06h	06h	06h
	CRC value	01A02h	2	Per unit	Per unit	Per unit	Per unit
	Device ID	01A04h	1	47h	45h	42h	40h
	Device ID	01A05h	1	81h	81h	81h	81h
	Hardware revision	01A06h	1	Per unit	Per unit	Per unit	Per unit
	Firmware revision	01A07h	1	Per unit	Per unit	Per unit	Per unit
Die Record	Die record tag	01A08h	1	08h	08h	08h	08h
	Die record length	01A09h	1	0Ah	0Ah	0Ah	0Ah
	Lot/wafer ID	01A0Ah	4	Per unit	Per unit	Per unit	Per unit
	Die X position	01A0Eh	2	Per unit	Per unit	Per unit	Per unit
	Die Y position	01A10h	2	Per unit	Per unit	Per unit	Per unit
	Test results	01A12h	2	Per unit	Per unit	Per unit	Per unit
ADC10 Calibration	ADC10 calibration tag	01A14h	1	13h	13h	13h	13h
	ADC10 calibration length	01A15h	1	10h	10h	10h	10h
	ADC gain factor	01A16h	2	Blank	Blank	Blank	Blank
	ADC offset	01A18h	2	Blank	Blank	Blank	Blank
	ADC 1.5-V reference Temperature sensor 30°C	01A1Ah	2	Blank	Blank	Blank	Blank
	ADC 1.5-V Reference Temperature sensor 85°C	01A1Ch	2	Blank	Blank	Blank	Blank
	ADC 2.0-V reference Temperature sensor 30°C	01A1Eh	2	Blank	Blank	Blank	Blank
	ADC 2.0-V reference Temperature sensor 85°C	01A20h	2	Blank	Blank	Blank	Blank
	ADC 2.5-V reference Temperature sensor 30°C	01A22h	2	Blank	Blank	Blank	Blank
	ADC 2.5-V reference Temperature sensor 85°C	01A24h	2	Blank	Blank	Blank	Blank
REF Calibration	REF calibration tag	01A26h	1	12h	12h	12h	12h
	REF calibration length	01A27h	1	06h	06h	06h	06h
	REF 1.5-V reference factor	01A28h	2	Per unit	Per unit	Per unit	Per unit
	REF 2.0-V reference factor	01A2Ah	2	Per unit	Per unit	Per unit	Per unit
	REF 2.5-V reference factor	01A2Ch	2	Per unit	Per unit	Per unit	Per unit

(1) NA = Not applicable, Blank = unused and reads FFh

**Table 6-55. MSP430F521x Device Descriptor Table<sup>(1)</sup> (continued)**

DESCRIPTION	ADDRESS	SIZE (BYTES)	VALUE			
			F5219	F5217	F5214	F5212
Peripheral descriptor tag	01A2Eh	1	02h	02h	02h	02h
Peripheral descriptor length	01A2Fh	1	5Dh	5Dh	5Bh	5Bh
Memory 1		2	08h 8Ah	08h 8Ah	08h 8Ah	08h 8Ah
Memory 2		2	0Ch 86h	0Ch 86h	0Ch 86h	0Ch 86h
Memory 3		2	12h 2Eh	12h 2Eh	12h 2Eh	12h 2Eh
Memory 4		2	22h 96h	22h 94h	22h 96h	22h 94h
Memory 5		2	N/A	N/A	N/A	N/A
Memory 6		1/2	N/A	N/A	N/A	N/A
Delimiter		1	00h	00h	00h	00h
Peripheral count		1	1Fh	1Fh	1Eh	1Eh
MSP430CPUXV2		2	00h 23h	00h 23h	00h 23h	00h 23h
JTAG		2	00h 09h	00h 09h	00h 09h	00h 09h
SBW		2	00h 0Fh	00h 0Fh	00h 0Fh	00h 0Fh
EEM-S		2	00h 03h	00h 03h	00h 03h	00h 05h
TI BSL		2	00h FCh	00h FCh	00h FCh	00h FCh
SFR		2	10h 41h	10h 41h	10h 41h	10h 41h
PMM		2	02h 30h	02h 30h	02h 30h	02h 30h
FCTL		2	02h 38h	02h 38h	02h 38h	02h 38h
CRC16		2	01h 3Ch	01h 3Ch	01h 3Ch	01h 3Ch
CRC16_RB		2	00h 3Dh	00h 3Dh	00h 3Dh	00h 3Dh
RAMCTL		2	00h 44h	00h 44h	00h 44h	00h 44h
WDT_A		2	00h 40h	00h 40h	00h 40h	00h 40h
UCS		2	01h 48h	01h 48h	01h 48h	01h 48h
SYS		2	02h 42h	02h 42h	02h 42h	02h 42h
REF		2	03h A0h	03h A0h	03h A0h	03h A0h
Port mapping		2	01h 10h	01h 10h	01h 10h	01h 10h
Port 1/2		2	04h 51h	04h 51h	04h 51h	04h 51h
Port 3/4		2	02h 52h	02h 52h	02h 52h	02h 52h
Port 5/6		2	02h 53h	02h 53h	02h 53h	02h 53h

Peripheral  
Descriptor

**Table 6-55. MSP430F521x Device Descriptor Table<sup>(1)</sup> (continued)**

DESCRIPTION	ADDRESS	SIZE (BYTES)	VALUE			
			F5219	F5217	F5214	F5212
Peripheral Descriptor (continued)	Port 7/8	2	02h 54h	02h 54h	N/A	N/A
	JTAG	2	0Ch 5Fh	0Ch 5Fh	0Eh 5Fh	0Eh 5Fh
	TA0	2	02h 62h	02h 62h	02h 62h	02h 62h
	TA1	2	04h 61h	04h 61h	04h 61h	04h 61h
	TB0	2	04h 67h	04h 67h	04h 67h	04h 67h
	TA2	2	04h 61h	04h 61h	04h 61h	04h 61h
	RTC	2	0Ah 68h	0Ah 68h	0Ah 68h	0Ah 68h
	MPY32	2	02h 85h	02h 85h	02h 85h	02h 85h
	DMA-3	2	04h 47h	04h 47h	04h 47h	04h 47h
	USCI_A/B	2	0Ch 90h	0Ch 90h	0Ch 90h	0Ch 90h
	USCI_A/B	2	04h 90h	04h 90h	04h 90h	04h 90h
	ADC10_A	2	N/A	N/A	N/A	N/A
	COMP_B	2	2Ch A8h	2Ch A8h	2Ch A8h	2Ch A8h
Interrupts	COMP_B	1	A8h	A8h	A8h	A8h
	TB0.CCIFG0	1	64h	64h	64h	64h
	TB0.CCIFG1..6	1	65h	65h	65h	65h
	WDTIFG	1	40h	40h	40h	40h
	USCI_A0	1	90h	90h	90h	90h
	USCI_B0	1	91h	91h	91h	91h
	Reserved	1	01h	01h	01h	01h
	TA0.CCIFG0	1	60h	60h	60h	60h
	TA0.CCIFG1..4	1	61h	61h	61h	61h
	Reserved	1	01h	01h	01h	01h
	DMA	1	46h	46h	46h	46h
	TA1.CCIFG0	1	62h	62h	62h	62h
	TA1.CCIFG1..2	1	63h	63h	63h	63h
	P1	1	50h	50h	50h	50h
	USCI_A1	1	92h	92h	92h	92h
	USCI_B1	1	93h	93h	93h	93h
	TA2.CCIFG0	1	66h	66h	66h	66h
	TA2.CCIFG1..2	1	67h	67h	67h	67h
P2	1	51h	51h	51h	51h	
RTC_A	1	68h	68h	68h	68h	
Delimiter	1	00h	00h	00h	00h	

## 7 Device and Documentation Support

### 7.1 Getting Started

For more information on the MSP430 family of devices and the tools and libraries that are available to help with your development, visit the [MSP430 ultra-low-power sensing and measurement MCUs overview](#).

### 7.2 Device Nomenclature

To designate the stages in the product development cycle, TI assigns prefixes to the part numbers of all MSP MCU devices. Each MSP MCU commercial family member has one of two prefixes: MSP or XMS. These prefixes represent evolutionary stages of product development from engineering prototypes (XMS) through fully qualified production devices (MSP).

**XMS** – Experimental device that is not necessarily representative of the final device's electrical specifications

**MSP** – Fully qualified production device

XMS devices are shipped against the following disclaimer:

"Developmental product is intended for internal evaluation purposes."

MSP devices have been characterized fully, and the quality and reliability of the device have been demonstrated fully. TI's standard warranty applies.

Predictions show that prototype devices (XMS) have a greater failure rate than the standard production devices. TI recommends that these devices not be used in any production system because their expected end-use failure rate still is undefined. Only qualified production devices are to be used.

TI device nomenclature also includes a suffix with the device family name. This suffix indicates the temperature range, package type, and distribution format. [Figure 7-1](#) provides a legend for reading the complete device name.

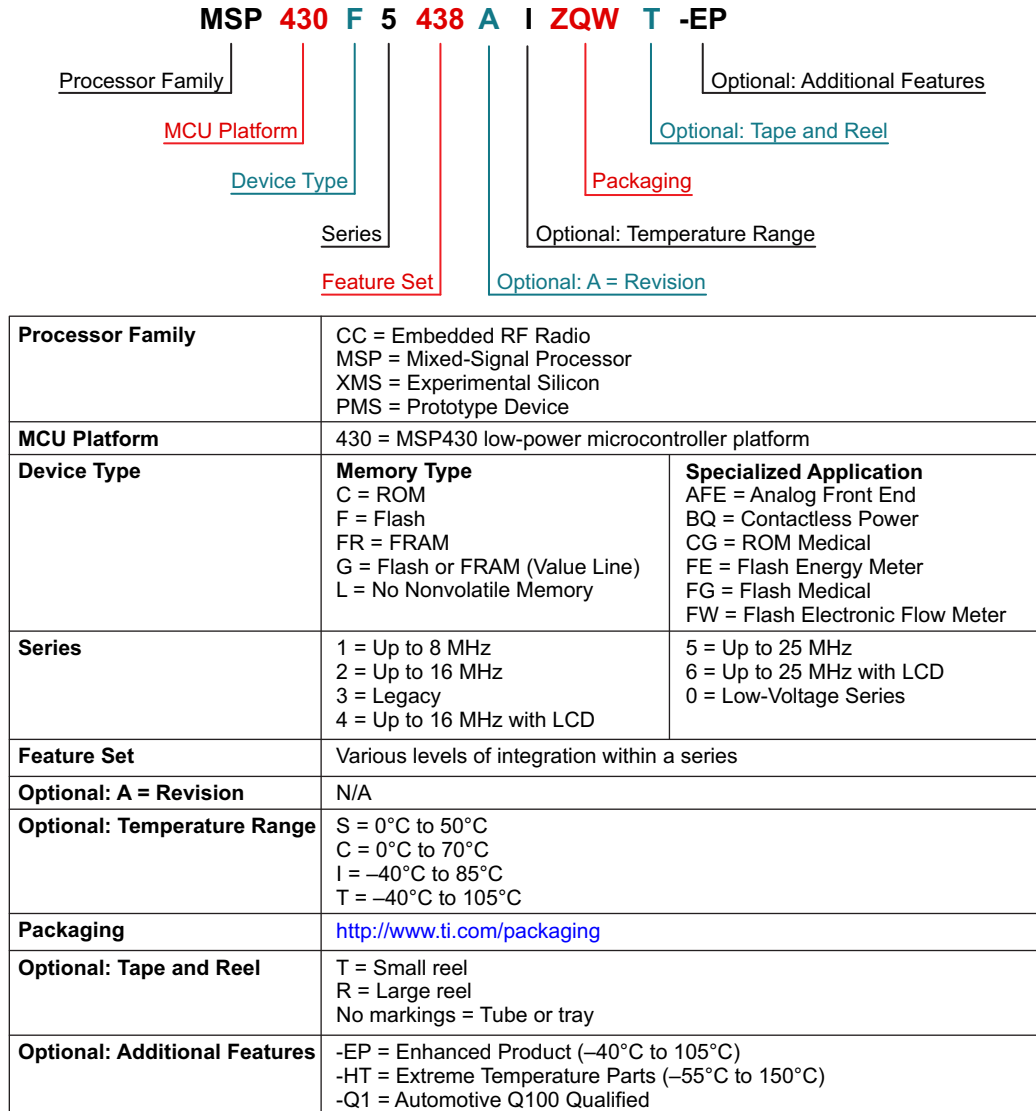

**Figure 7-1. Device Nomenclature**

## 7.3 Tools and Software

All MSP microcontrollers are supported by a wide variety of software and hardware development tools. Tools are available from TI and various third parties. See them all at [MSP430 Ultra-Low-Power MCUs – Tools & software](#).

Table 7-1 lists the debug features of the MSP430F522x and MSP430F521x MCUs. See the [Code Composer Studio for MSP430 User's Guide](#) for details on the available features.

**Table 7-1. Hardware Debug Features**

MSP430 ARCHITECTURE	4-WIRE JTAG	2-WIRE JTAG	BREAK-POINTS (N)	RANGE BREAK-POINTS	CLOCK CONTROL	STATE SEQUENCER	TRACE BUFFER	LPMx.5 DEBUGGING SUPPORT	EnergyTrace++ Technology
MSP430Xv2	Yes	Yes	3	Yes	Yes	No	No	Yes	Yes

### Design Kits and Evaluation Modules

**MSP-TS430RGC64C - 64-pin Target Development Board for MSP430F5x MCUs** The MSP-TS430RGC64C is a stand-alone 64-pin ZIF socket target board used to program and debug the MSP430 MCU in system through the JTAG interface or the Spy-Bi-Wire (2-wire JTAG) protocol.

**Bluetooth® and MSP430 Audio Source Reference Design Board** The Bluetooth and MSP430 Audio Source reference design can be used by customers to create a variety of applications for low-end, low-power audio source solutions for applications including toys, projectors, smart remotes and any audio streaming accessories.

**Dual-Mode Bluetooth CC2564 Module With Integrated Antenna Evaluation Board** The CC2564MODAEM evaluation board contains the Bluetooth BR/EDR/LE HCI solution. Based on TI's CC2564B dual-mode Bluetooth single-chip device, the bCC2564MODA is intended for evaluation and design purposes, reducing design effort and enabling fast time to market.

### Software

**MSP430Ware™ Software** MSP430Ware software is a collection of code examples, data sheets, and other design resources for all MSP430 devices delivered in a convenient package. In addition to providing a complete collection of existing MSP430 MCU design resources, MSP430Ware software also includes a high-level API called MSP Driver Library. This library makes it easy to program MSP430 hardware. MSP430Ware software is available as a component of CCS or as a stand-alone package.

**MSP430F522x, MSP430F521x Code Examples** C code examples that configure each of the integrated peripherals for various application needs.

**MSP Driver Library** The abstracted API of MSP Driver Library provides easy-to-use function calls that free you from directly manipulating the bits and bytes of the MSP430 hardware. Thorough documentation is delivered through a helpful API Guide, which includes details on each function call and the recognized parameters. Developers can use Driver Library functions to write complete projects with minimal overhead.

**MSP EnergyTrace™ Technology** EnergyTrace technology for MSP430 microcontrollers is an energy-based code analysis tool that measures and displays the energy profile of the application and helps to optimize it for ultra-low-power consumption.

**ULP (Ultra-Low Power) Advisor** ULP Advisor™ software is a tool for guiding developers to write more efficient code to fully use the unique ultra-low-power features of MSP and MSP432 microcontrollers. Aimed at both experienced and new microcontroller developers, ULP Advisor checks your code against a thorough ULP checklist to help minimize the energy consumption of your application. At build time, ULP Advisor provides notifications and remarks to highlight areas of your code that can be further optimized for lower power.

**IEC60730 Software Package** The IEC60730 MSP430 software package was developed to help customers comply with IEC 60730-1:2010 (Automatic Electrical Controls for Household and Similar Use – Part 1: General Requirements) for up to Class B products, which includes home appliances, arc detectors, power converters, power tools, e-bikes, and many others. The IEC60730 MSP430 software package can be embedded in customer applications running on MSP430s to help simplify the customer's certification efforts of functional safety-compliant consumer devices to IEC 60730-1:2010 Class B.

**Fixed Point Math Library for MSP** The MSP IQmath and Qmath Libraries are a collection of highly optimized and high-precision mathematical functions for C programmers to seamlessly port a floating-point algorithm into fixed-point code on MSP430 and MSP432 devices. These routines are typically used in computationally intensive real-time applications where optimal execution speed, high accuracy, and ultra-low energy are critical. By using the IQmath and Qmath libraries, it is possible to achieve execution speeds considerably faster and energy consumption considerably lower than equivalent code written using floating-point math.

**Floating Point Math Library for MSP430** Continuing to innovate in the low-power and low-cost microcontroller space, TI provides MSPMATHLIB. Leveraging the intelligent peripherals of our devices, this floating-point math library of scalar functions that are up to 26 times faster than the standard MSP430 math functions. Mathlib is easy to integrate into your designs. This library is free and is integrated in both Code Composer Studio IDE and IAR Embedded Workbench IDE.

## Development Tools

**Code Composer Studio™ Integrated Development Environment for MSP Microcontrollers** Code Composer Studio (CCS) integrated development environment (IDE) supports all MSP microcontroller devices. CCS comprises a suite of embedded software utilities used to develop and debug embedded applications. CCS includes an optimizing C/C++ compiler, source code editor, project build environment, debugger, profiler, and many other features.

**Command-Line Programmer** MSP Flasher is an open-source shell-based interface for programming MSP microcontrollers through a FET programmer or eZ430 using JTAG or Spy-Bi-Wire (SBW) communication. MSP Flasher can download binary files (.txt or .hex) directly to the MSP microcontroller without an IDE.

**MSP MCU Programmer and Debugger** The MSP-FET is a powerful emulation development tool – often called a debug probe – which lets users quickly begin application development on MSP low-power MCUs. Creating MCU software usually requires downloading the resulting binary program to the MSP device for validation and debugging.

**MSP-GANG Production Programmer** The MSP Gang Programmer is an MSP430 or MSP432 device programmer that can program up to eight identical MSP430 or MSP432 flash or FRAM devices at the same time. The MSP Gang Programmer connects to a host PC using a standard RS-232 or USB connection and provides flexible programming options that let the user fully customize the process.

## 7.4 Documentation Support

The following documents describe the MSP430F522x and MSP430F521x MCUs. Copies of these documents are available on the Internet at [www.ti.com](http://www.ti.com).

### Receiving Notification of Document Updates

To receive notification of documentation updates—including silicon errata—go to the product folder for your device on [ti.com](http://ti.com) (see [Section 7.5](#) for links to product folders). In the upper right corner, click the "Alert me" button. This registers you to receive a weekly digest of product information that has changed (if any). For change details, check the revision history of any revised document.

### Errata

**MSP430F5229 Device Erratasheet** Describes the known exceptions to the functional specifications for the MSP430F5229 device.

**MSP430F5227 Device Erratasheet** Describes the known exceptions to the functional specifications for the MSP430F5227 device.

**MSP430F5224 Device Erratasheet** Describes the known exceptions to the functional specifications for the MSP430F5224 device.

**MSP430F5222 Device Erratasheet** Describes the known exceptions to the functional specifications for the MSP430F5222 device.

**MSP430F5219 Device Erratasheet** Describes the known exceptions to the functional specifications for the MSP430F5219 device.

**MSP430F5217 Device Erratasheet** Describes the known exceptions to the functional specifications for the MSP430F5217 device.

**MSP430F5214 Device Erratasheet** Describes the known exceptions to the functional specifications for the MSP430F5214 device.

**MSP430F5212 Device Erratasheet** Describes the known exceptions to the functional specifications for the MSP430F5212 device.

### User's Guides

**MSP430F5xx and MSP430F6xx Family User's Guide** Detailed information on the modules and peripherals available in this device family.

**MSP430 Flash Device Bootloader (BSL) User's Guide** The MSP430 bootloader (BSL) (formerly known as the bootstrap loader) lets users communicate with embedded memory in the MSP430 microcontroller during the prototyping phase, final production, and in service. Both the programmable memory (flash memory) and the data memory (RAM) can be modified as required. Do not confuse the bootloader with the bootstrap loader programs found in some digital signal processors (DSPs) that automatically load program code (and data) from external memory to the internal memory of the DSP.

**MSP430 Programming With the JTAG Interface** This document describes the functions that are required to erase, program, and verify the memory module of the MSP430 flash-based and FRAM-based microcontroller families using the JTAG communication port. In addition, it describes how to program the JTAG access security fuse that is available on all MSP430 devices. This document describes device access using both the standard 4-wire JTAG interface and the 2-wire JTAG interface, which is also referred to as Spy-Bi-Wire (SBW).

**MSP430 Hardware Tools User's Guide** This manual describes the hardware of the TI MSP-FET430 Flash Emulation Tool (FET). The FET is the program development tool for the MSP430 ultra-low-power microcontroller.

### Application Reports

**Designing with MSP430F522x and MSP430F521x Devices** The MSP430F522x and MSP430F521x devices support a split supply I/O system that is essential in systems in which the MCU is required to interface with external devices (such as sensors or other processors) that operate at different voltage level compared to the MCU device supply. Additionally, the split supply input voltage range of the F522x and F521x devices starts as low as 1.62 V (see the device data sheet specifications), and this allows for nominal 1.8-V I/O interface without the need for external level translation. This application report describes the various design considerations to keep in mind while designing the F522x and F521x devices in an application.

**General Oversampling of MSP ADCs for Higher Resolution** Multiple MSP ultra-low-power microcontrollers offer analog-to-digital converters (ADCs) to convert physical quantities into digital numbers, a function that is widely used across numerous applications. There are times, however, when a customer design demands a higher resolution than the ADC of the selected MSP can offer. This application report, which is based on the previously-published Oversampling the ADC12 for Higher Resolution (SLAA323), therefore describes how an oversampling method can be incorporated to increase ADC resolution past the currently available number of bits.

**MSP430 32-kHz Crystal Oscillators** Selection of the correct crystal, correct load circuit, and proper board layout are important for a stable crystal oscillator. This application report summarizes crystal oscillator function and explains the parameters to select the correct crystal for MSP430 ultra-low-power operation. In addition, hints and examples for correct board layout are given. The document also contains detailed information on the possible oscillator tests to ensure stable oscillator operation in mass production.

**MSP430 System-Level ESD Considerations** System-Level ESD has become increasingly demanding as silicon technology scales to lower voltages and the need for designing cost-effective and ultra-low-power components. This application report addresses three ESD topics to help board designers and OEMs understand and design robust system-level designs: (1) Component-level ESD testing and system-level ESD testing; (2) General design guidelines for system-level ESD protection; (3) Introduction to System Efficient ESD Design (SEED), a co-design methodology of on-board and on-chip ESD protection. A few real-world system-level ESD protection design examples and their results are discussed.

## 7.5 Related Links

[Table 7-2](#) lists quick access links. Categories include technical documents, support and community resources, tools and software, and quick access to sample or buy.

**Table 7-2. Related Links**

PARTS	PRODUCT FOLDER	ORDER NOW	TECHNICAL DOCUMENTS	TOOLS & SOFTWARE	SUPPORT & COMMUNITY
MSP430F5229	<a href="#">Click here</a>	<a href="#">Click here</a>	<a href="#">Click here</a>	<a href="#">Click here</a>	<a href="#">Click here</a>
MSP430F5227	<a href="#">Click here</a>	<a href="#">Click here</a>	<a href="#">Click here</a>	<a href="#">Click here</a>	<a href="#">Click here</a>
MSP430F5224	<a href="#">Click here</a>	<a href="#">Click here</a>	<a href="#">Click here</a>	<a href="#">Click here</a>	<a href="#">Click here</a>
MSP430F5222	<a href="#">Click here</a>	<a href="#">Click here</a>	<a href="#">Click here</a>	<a href="#">Click here</a>	<a href="#">Click here</a>
MSP430F5219	<a href="#">Click here</a>	<a href="#">Click here</a>	<a href="#">Click here</a>	<a href="#">Click here</a>	<a href="#">Click here</a>
MSP430F5217	<a href="#">Click here</a>	<a href="#">Click here</a>	<a href="#">Click here</a>	<a href="#">Click here</a>	<a href="#">Click here</a>
MSP430F5214	<a href="#">Click here</a>	<a href="#">Click here</a>	<a href="#">Click here</a>	<a href="#">Click here</a>	<a href="#">Click here</a>
MSP430F5212	<a href="#">Click here</a>	<a href="#">Click here</a>	<a href="#">Click here</a>	<a href="#">Click here</a>	<a href="#">Click here</a>

## 7.6 Community Resources

The following links connect to TI community resources. Linked contents are provided "AS IS" by the respective contributors. They do not constitute TI specifications and do not necessarily reflect TI's views; see TI's [Terms of Use](#).

### [TI E2E™ Community](#)

*TI's Engineer-to-Engineer (E2E) Community.* Created to foster collaboration among engineers. At [e2e.ti.com](http://e2e.ti.com), you can ask questions, share knowledge, explore ideas, and help solve problems with fellow engineers.

### [TI Embedded Processors Wiki](#)

*Texas Instruments Embedded Processors Wiki.* Established to help developers get started with embedded processors from Texas Instruments and to foster innovation and growth of general knowledge about the hardware and software surrounding these devices.

## 7.7 Trademarks

MSP430, MSP430Ware, EnergyTrace, ULP Advisor, Code Composer Studio, E2E are trademarks of Texas Instruments.

Bluetooth is a registered trademark of Bluetooth SIG.

All other trademarks are the property of their respective owners.

## 7.8 Electrostatic Discharge Caution



This integrated circuit can be damaged by ESD. Texas Instruments recommends that all integrated circuits be handled with appropriate precautions. Failure to observe proper handling and installation procedures can cause damage.

ESD damage can range from subtle performance degradation to complete device failure. Precision integrated circuits may be more susceptible to damage because very small parametric changes could cause the device not to meet its published specifications.

## 7.9 Glossary

[TI Glossary](#) This glossary lists and explains terms, acronyms, and definitions.

## 8 Mechanical, Packaging, and Orderable Information

The following pages include mechanical, packaging, and orderable information. This information is the most current data available for the designated devices. This data is subject to change without notice and revision of this document. For browser-based versions of this data sheet, refer to the left-hand navigation.

**PACKAGING INFORMATION**

Orderable Device	Status (1)	Package Type	Package Drawing	Pins	Package Qty	Eco Plan (2)	Lead/Ball Finish (6)	MSL Peak Temp (3)	Op Temp (°C)	Device Marking (4/5)	Samples
MSP430F5212IRGZT	ACTIVE	VQFN	RGZ	48	250	Green (RoHS & no Sb/Br)	CU NIPDAU	Level-3-260C-168 HR	-40 to 85	F5212	<a href="#">Samples</a>
MSP430F5214IRGZR	ACTIVE	VQFN	RGZ	48	2500	Green (RoHS & no Sb/Br)	CU NIPDAU	Level-3-260C-168 HR	-40 to 85	F5214	<a href="#">Samples</a>
MSP430F5217IRGCT	ACTIVE	VQFN	RGC	64	250	Green (RoHS & no Sb/Br)	CU NIPDAU	Level-3-260C-168 HR	-40 to 85	F5217	<a href="#">Samples</a>
MSP430F52171YFFR	ACTIVE	DSBGA	YFF	64	2500	Green (RoHS & no Sb/Br)	SNAGCU	Level-1-260C-UNLIM	-40 to 85	M430F5217	<a href="#">Samples</a>
MSP430F5217IZQE	OBSOLETE	BGA MICROSTAR JUNIOR	ZQE	80		TBD	Call TI	Call TI	-40 to 85	F5217	
MSP430F5219IYFFT	ACTIVE	DSBGA	YFF	64	250	Green (RoHS & no Sb/Br)	SNAGCU	Level-1-260C-UNLIM	-40 to 85	M430F5219	<a href="#">Samples</a>
MSP430F5219IZQE	ACTIVE	BGA MICROSTAR JUNIOR	ZQE	80	490	Green (RoHS & no Sb/Br)	SNAGCU	Level-3-260C-168 HR	-40 to 85	F5219	<a href="#">Samples</a>
MSP430F5222IRGZR	ACTIVE	VQFN	RGZ	48	2500	Green (RoHS & no Sb/Br)	CU NIPDAU	Level-3-260C-168 HR	-40 to 85	F5222	<a href="#">Samples</a>
MSP430F5222IRGZT	ACTIVE	VQFN	RGZ	48	250	Green (RoHS & no Sb/Br)	CU NIPDAU	Level-3-260C-168 HR	-40 to 85	F5222	<a href="#">Samples</a>
MSP430F5224IRGZR	ACTIVE	VQFN	RGZ	48	2500	Green (RoHS & no Sb/Br)	CU NIPDAU	Level-3-260C-168 HR	-40 to 85	F5224	<a href="#">Samples</a>
MSP430F5227IZQE	ACTIVE	BGA MICROSTAR JUNIOR	ZQE	80	490	Green (RoHS & no Sb/Br)	SNAGCU	Level-3-260C-168 HR	-40 to 85	F5227	<a href="#">Samples</a>
MSP430F5229IRGCR	ACTIVE	VQFN	RGC	64	2000	Green (RoHS & no Sb/Br)	CU NIPDAU	Level-3-260C-168 HR	-40 to 85	F5229	<a href="#">Samples</a>
MSP430F5229IRGCT	ACTIVE	VQFN	RGC	64	250	Green (RoHS & no Sb/Br)	CU NIPDAU	Level-3-260C-168 HR	-40 to 85	F5229	<a href="#">Samples</a>
MSP430F52291YFFR	ACTIVE	DSBGA	YFF	64	2500	Green (RoHS & no Sb/Br)	SNAGCU	Level-1-260C-UNLIM	-40 to 85	M430F5229	<a href="#">Samples</a>
MSP430F52291YFFT	ACTIVE	DSBGA	YFF	64	250	Green (RoHS & no Sb/Br)	SNAGCU	Level-1-260C-UNLIM	-40 to 85	M430F5229	<a href="#">Samples</a>

Orderable Device	Status (1)	Package Type	Package Drawing	Pins	Package Qty	Eco Plan (2)	Lead/Ball Finish (6)	MSL Peak Temp (3)	Op Temp (°C)	Device Marking (4/5)	Samples
MSP430F5229IZQE	OBSOLETE	BGA MICROSTAR JUNIOR	ZQE	80		TBD	Call TI	Call TI	-40 to 85	F5229	
MSP430F5229IZQER	OBSOLETE	BGA MICROSTAR JUNIOR	ZQE	80		TBD	Call TI	Call TI	-40 to 85	F5229	

(1) The marketing status values are defined as follows:

**ACTIVE:** Product device recommended for new designs.

**LIFEBUY:** TI has announced that the device will be discontinued, and a lifetime-buy period is in effect.

**NRND:** Not recommended for new designs. Device is in production to support existing customers, but TI does not recommend using this part in a new design.

**PREVIEW:** Device has been announced but is not in production. Samples may or may not be available.

**OBSOLETE:** TI has discontinued the production of the device.

(2) **RoHS:** TI defines "RoHS" to mean semiconductor products that are compliant with the current EU RoHS requirements for all 10 RoHS substances, including the requirement that RoHS substance do not exceed 0.1% by weight in homogeneous materials. Where designed to be soldered at high temperatures, "RoHS" products are suitable for use in specified lead-free processes. TI may reference these types of products as "Pb-Free".

**RoHS Exempt:** TI defines "RoHS Exempt" to mean products that contain lead but are compliant with EU RoHS pursuant to a specific EU RoHS exemption.

**Green:** TI defines "Green" to mean the content of Chlorine (Cl) and Bromine (Br) based flame retardants meet JS709B low halogen requirements of <=100ppm threshold. Antimony trioxide based flame retardants must also meet the <=1000ppm threshold requirement.

(3) MSL, Peak Temp. - The Moisture Sensitivity Level rating according to the JEDEC industry standard classifications, and peak solder temperature.

(4) There may be additional marking, which relates to the logo, the lot trace code information, or the environmental category on the device.

(5) Multiple Device Markings will be inside parentheses. Only one Device Marking contained in parentheses and separated by a "~" will appear on a device. If a line is indented then it is a continuation of the previous line and the two combined represent the entire Device Marking for that device.

(6) Lead/Ball Finish - Orderable Devices may have multiple material finish options. Finish options are separated by a vertical ruled line. Lead/Ball Finish values may wrap to two lines if the finish value exceeds the maximum column width.

**Important Information and Disclaimer:** The information provided on this page represents TI's knowledge and belief as of the date that it is provided. TI bases its knowledge and belief on information provided by third parties, and makes no representation or warranty as to the accuracy of such information. Efforts are underway to better integrate information from third parties. TI has taken and continues to take reasonable steps to provide representative and accurate information but may not have conducted destructive testing or chemical analysis on incoming materials and chemicals. TI and TI suppliers consider certain information to be proprietary, and thus CAS numbers and other limited information may not be available for release.

In no event shall TI's liability arising out of such information exceed the total purchase price of the TI part(s) at issue in this document sold by TI to Customer on an annual basis.

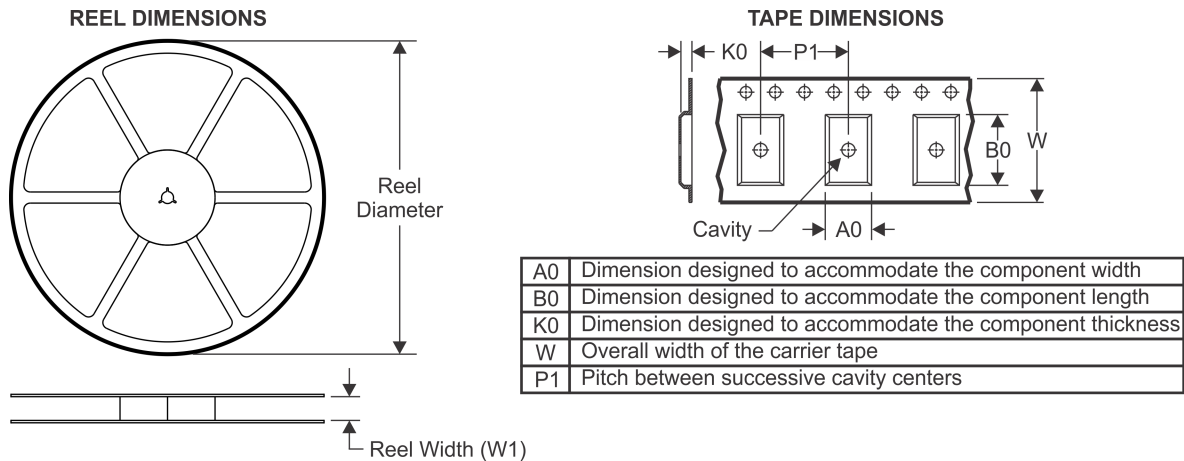
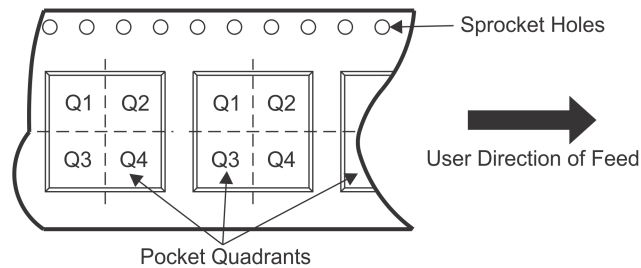
**TAPE AND REEL INFORMATION**

**QUADRANT ASSIGNMENTS FOR PIN 1 ORIENTATION IN TAPE**

\*All dimensions are nominal

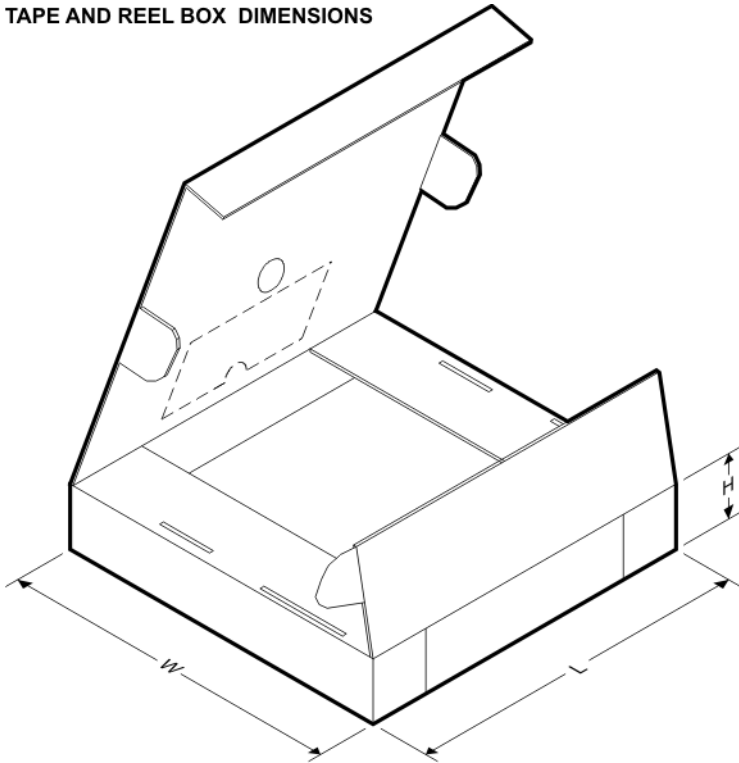
Device	Package Type	Package Drawing	Pins	SPQ	Reel Diameter (mm)	Reel Width W1 (mm)	A0 (mm)	B0 (mm)	K0 (mm)	P1 (mm)	W (mm)	Pin1 Quadrant
MSP430F5212IRGZT	VQFN	RGZ	48	250	180.0	16.4	7.3	7.3	1.1	12.0	16.0	Q2
MSP430F5214IRGZR	VQFN	RGZ	48	2500	330.0	16.4	7.3	7.3	1.1	12.0	16.0	Q2
MSP430F5217IRGCT	VQFN	RGC	64	250	180.0	16.4	9.3	9.3	1.1	12.0	16.0	Q2
MSP430F5217IYFFR	DSBGA	YFF	64	2500	330.0	12.4	3.54	3.66	0.81	8.0	12.0	Q2
MSP430F5219IYFFT	DSBGA	YFF	64	250	180.0	12.4	3.54	3.66	0.81	8.0	12.0	Q2
MSP430F5222IRGZR	VQFN	RGZ	48	2500	330.0	16.4	7.3	7.3	1.1	12.0	16.0	Q2
MSP430F5222IRGZT	VQFN	RGZ	48	250	180.0	16.4	7.3	7.3	1.1	12.0	16.0	Q2
MSP430F5224IRGZR	VQFN	RGZ	48	2500	330.0	16.4	7.3	7.3	1.1	12.0	16.0	Q2
MSP430F5229IRGCR	VQFN	RGC	64	2000	330.0	16.4	9.3	9.3	1.1	12.0	16.0	Q2
MSP430F5229IRGCT	VQFN	RGC	64	250	180.0	16.4	9.3	9.3	1.1	12.0	16.0	Q2
MSP430F5229IYFFR	DSBGA	YFF	64	2500	330.0	12.4	3.54	3.66	0.81	8.0	12.0	Q2
MSP430F5229IYFFT	DSBGA	YFF	64	250	180.0	12.4	3.54	3.66	0.81	8.0	12.0	Q2

**TAPE AND REEL BOX DIMENSIONS**

\*All dimensions are nominal

Device	Package Type	Package Drawing	Pins	SPQ	Length (mm)	Width (mm)	Height (mm)
MSP430F5212IRGZT	VQFN	RGZ	48	250	210.0	185.0	35.0
MSP430F5214IRGZR	VQFN	RGZ	48	2500	367.0	367.0	38.0
MSP430F5217IRGCT	VQFN	RGC	64	250	210.0	185.0	35.0
MSP430F5217IYFFR	DSBGA	YFF	64	2500	367.0	367.0	35.0
MSP430F5219IYFFT	DSBGA	YFF	64	250	210.0	185.0	35.0
MSP430F5222IRGZR	VQFN	RGZ	48	2500	367.0	367.0	38.0
MSP430F5222IRGZT	VQFN	RGZ	48	250	210.0	185.0	35.0
MSP430F5224IRGZR	VQFN	RGZ	48	2500	367.0	367.0	38.0
MSP430F5229IRGCR	VQFN	RGC	64	2000	367.0	367.0	38.0
MSP430F5229IRGCT	VQFN	RGC	64	250	210.0	185.0	35.0
MSP430F5229IYFFR	DSBGA	YFF	64	2500	367.0	367.0	35.0
MSP430F5229IYFFT	DSBGA	YFF	64	250	210.0	185.0	35.0

# MECHANICAL DATA

ZQE (S-PBGA-N80)

PLASTIC BALL GRID ARRAY

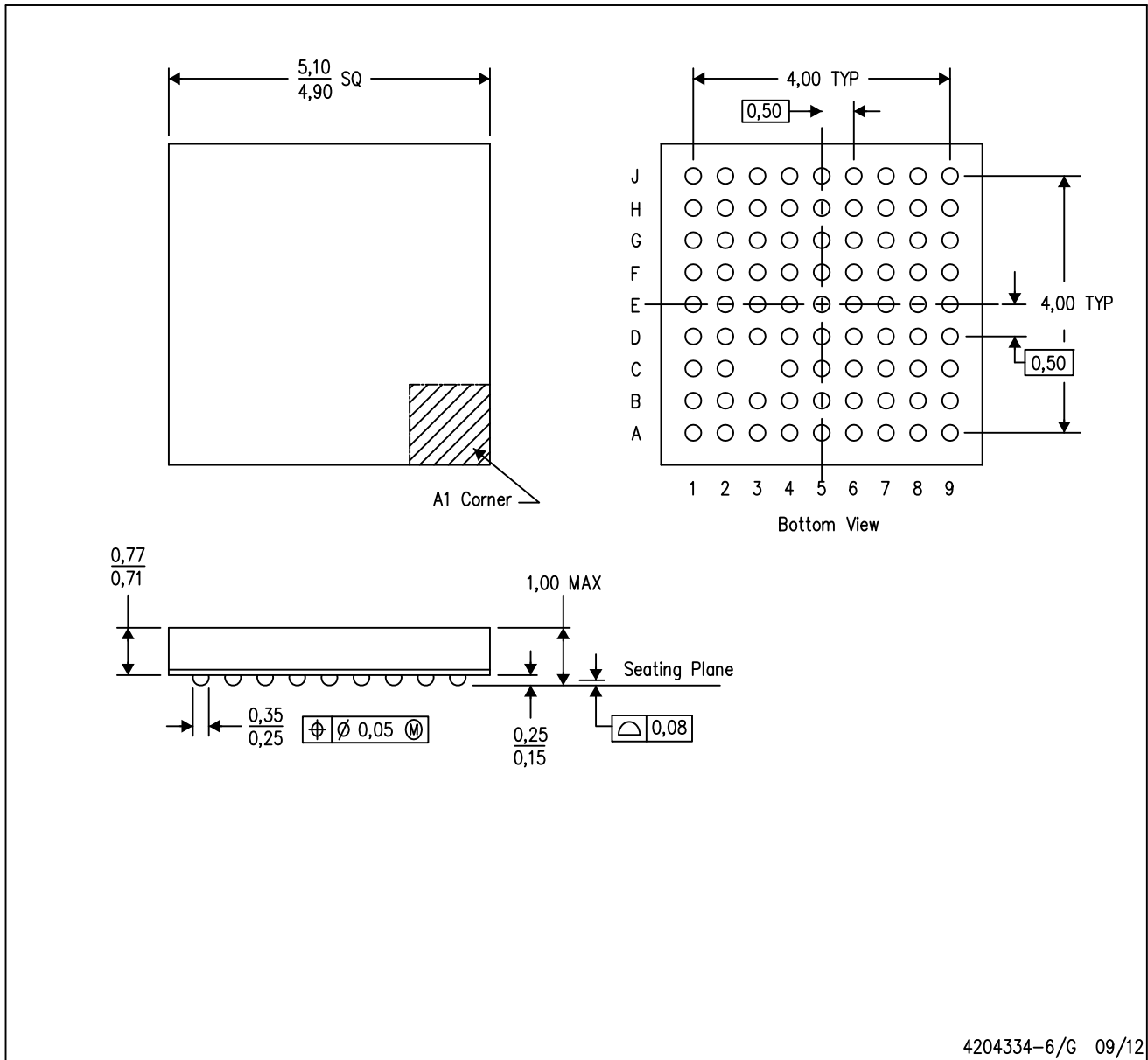

- NOTES:
- A. All linear dimensions are in millimeters. Dimensioning and tolerancing per ASME Y14.5M-1994.
  - B. This drawing is subject to change without notice.
  - C. Falls within JEDEC MO-225
  - D. This is a Pb-free solder ball design.

MicroStar Junior is a trademark of Texas Instruments.

## GENERIC PACKAGE VIEW

**RGC 64**

**VQFN - 1 mm max height**

9 x 9, 0.5 mm pitch

PLASTIC QUAD FLATPACK - NO LEAD

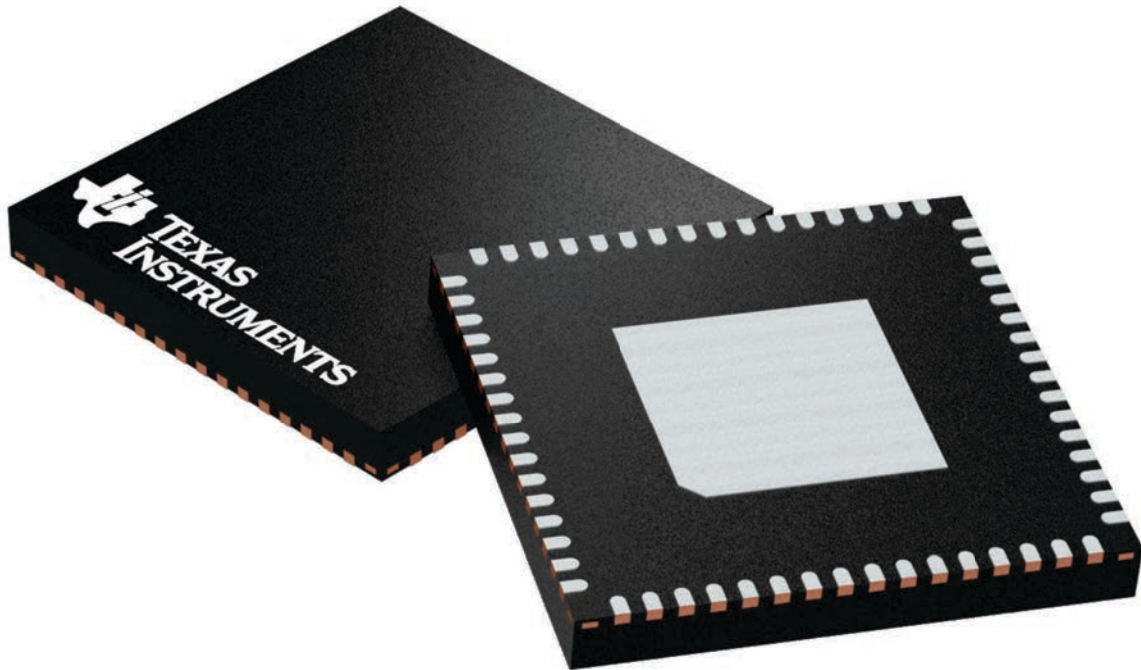

Images above are just a representation of the package family, actual package may vary.  
Refer to the product data sheet for package details.

4224597/A



# EXAMPLE BOARD LAYOUT

**RGC0064B**

**VQFN - 1 mm max height**

PLASTIC QUAD FLATPACK - NO LEAD

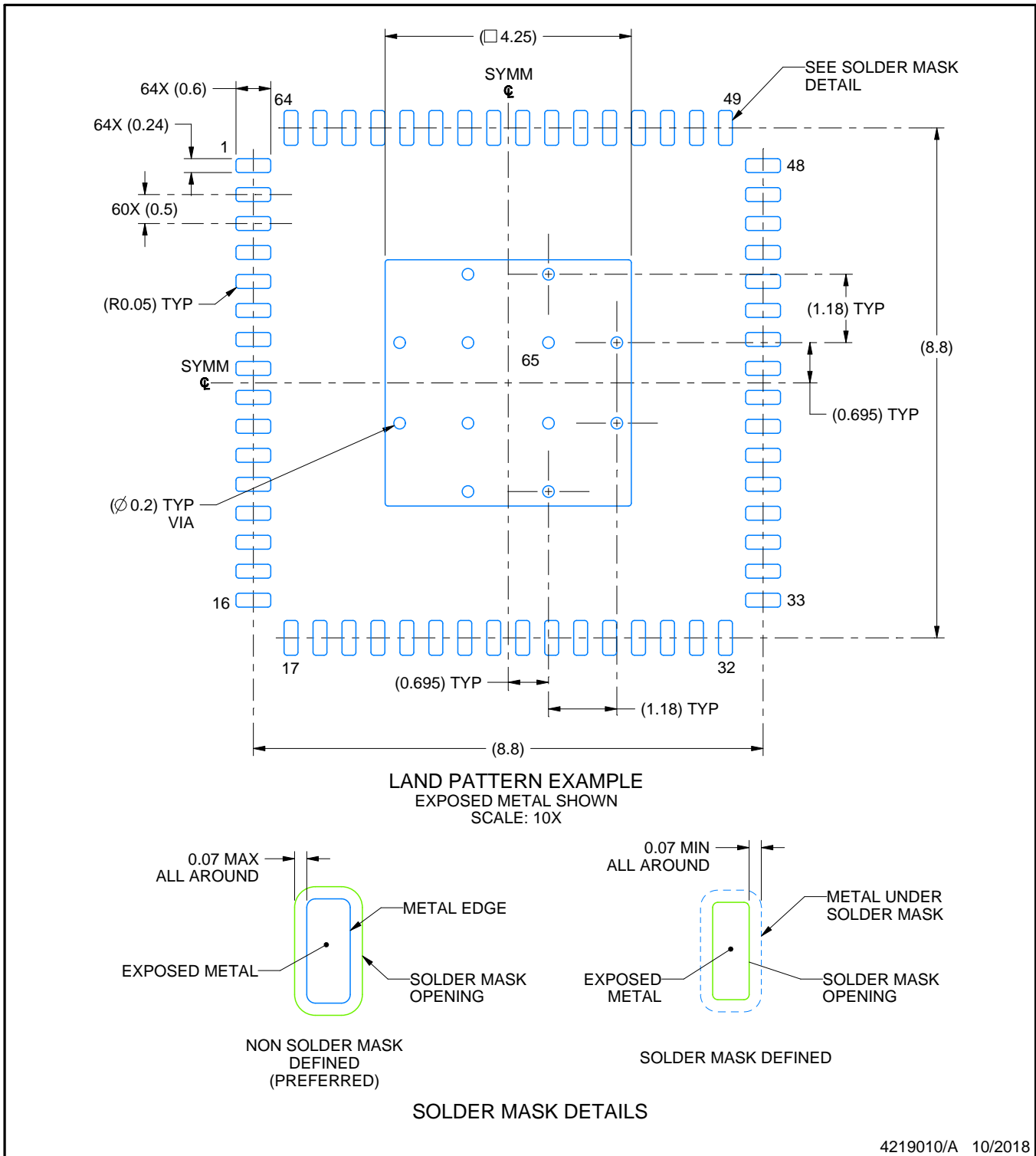

4219010/A 10/2018

NOTES: (continued)

4. This package is designed to be soldered to a thermal pad on the board. For more information, see Texas Instruments literature number SLUA271 ([www.ti.com/lit/slua271](http://www.ti.com/lit/slua271)).
5. Vias are optional depending on application, refer to device data sheet. If any vias are implemented, refer to their locations shown on this view. It is recommended that vias under paste be filled, plugged or tented.

# EXAMPLE STENCIL DESIGN

RGC0064B

VQFN - 1 mm max height

PLASTIC QUAD FLATPACK - NO LEAD

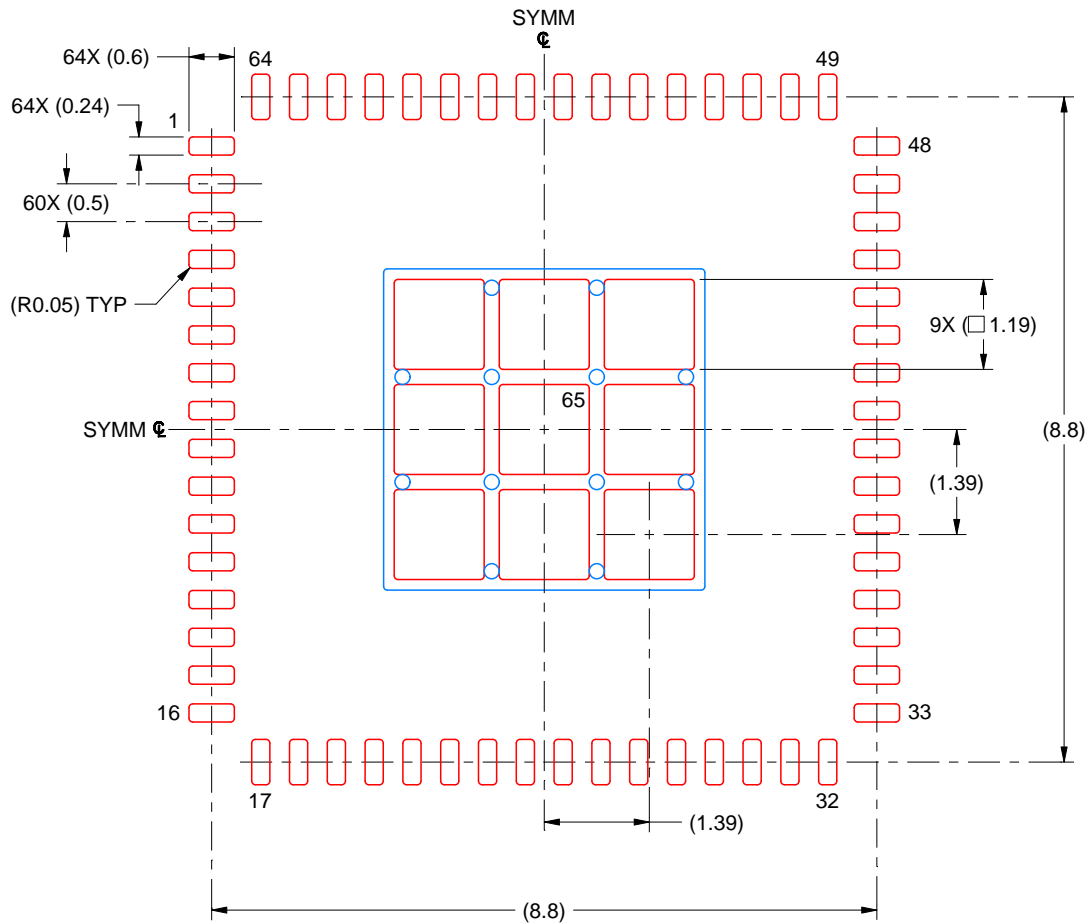

SOLDER PASTE EXAMPLE  
 BASED ON 0.125 MM THICK STENCIL  
 SCALE: 10X

EXPOSED PAD 65  
 71% PRINTED SOLDER COVERAGE BY AREA UNDER PACKAGE

4219010/A 10/2018

NOTES: (continued)

6. Laser cutting apertures with trapezoidal walls and rounded corners may offer better paste release. IPC-7525 may have alternate design recommendations.

## GENERIC PACKAGE VIEW

**RGZ 48**

**VQFN - 1 mm max height**

7 x 7, 0.5 mm pitch

PLASTIC QUADFLAT PACK- NO LEAD

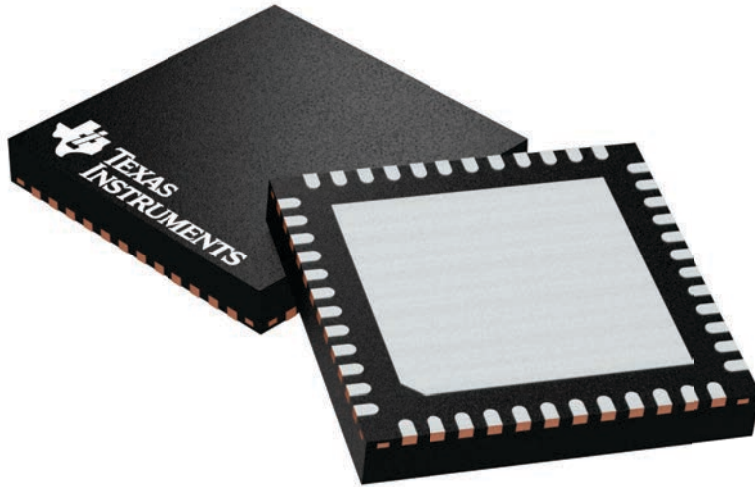

Images above are just a representation of the package family, actual package may vary.  
Refer to the product data sheet for package details.

4224671/A

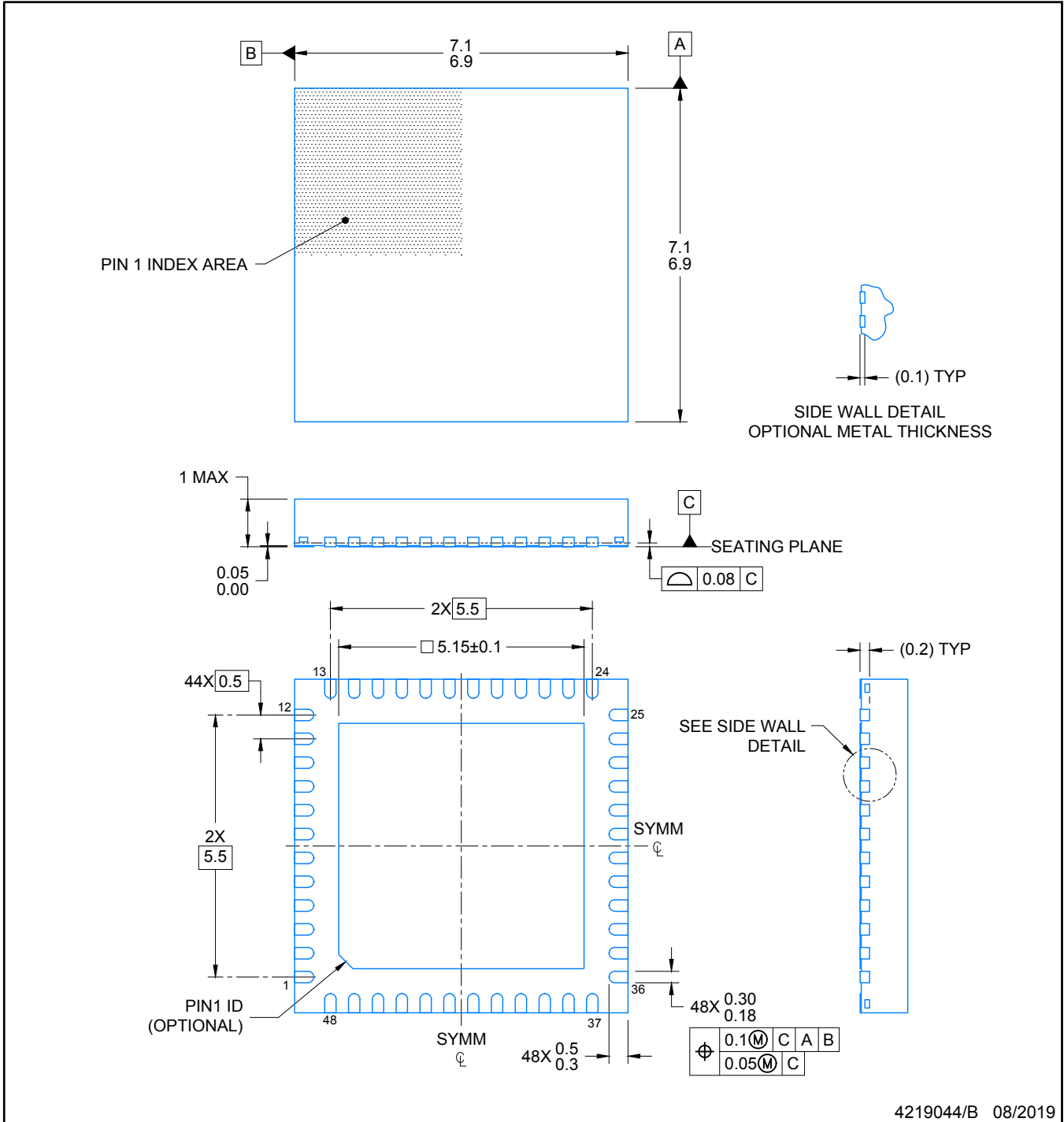

NOTES:

1. All linear dimensions are in millimeters. Any dimensions in parenthesis are for reference only. Dimensioning and tolerancing per ASME Y14.5M.
2. This drawing is subject to change without notice.
3. The package thermal pad must be soldered to the printed circuit board for optimal thermal and mechanical performance.

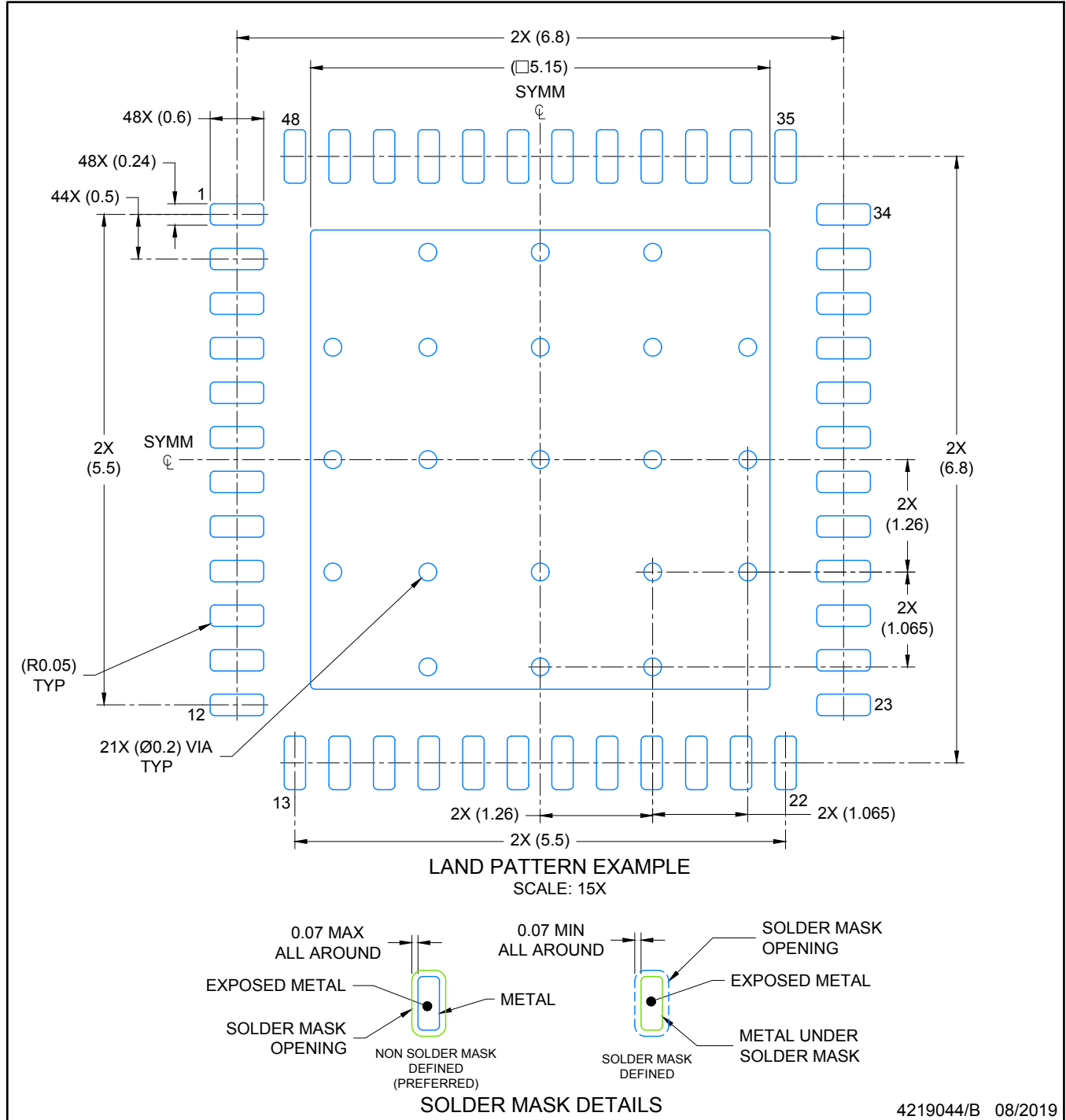

NOTES: (continued)

4. This package is designed to be soldered to a thermal pad on the board. For more information, see Texas Instruments literature number SLUA271 ([www.ti.com/lit/slua271](http://www.ti.com/lit/slua271)).
5. Vias are optional depending on application, refer to device data sheet. If any vias are implemented, refer to their locations shown on this view. It is recommended that vias under paste be filled, plugged or tented.

# EXAMPLE STENCIL DESIGN

RGZ0048A

VQFN - 1 mm max height

PLASTIC QUADFLAT PACK- NO LEAD

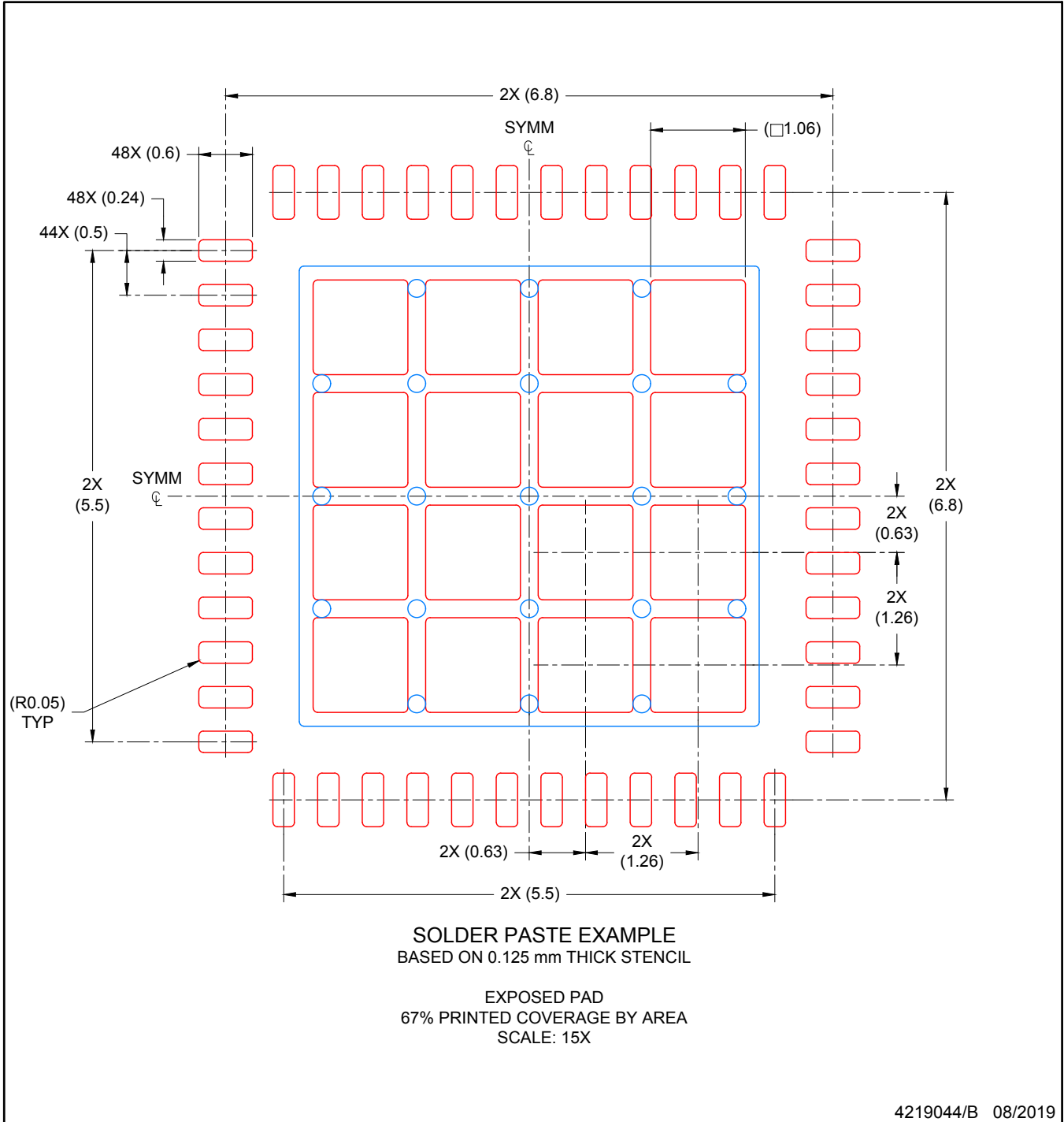

NOTES: (continued)

6. Laser cutting apertures with trapezoidal walls and rounded corners may offer better paste release. IPC-7525 may have alternate design recommendations.

# MECHANICAL DATA

YFF (R-XBGA-N64)

DIE-SIZE BALL GRID ARRAY

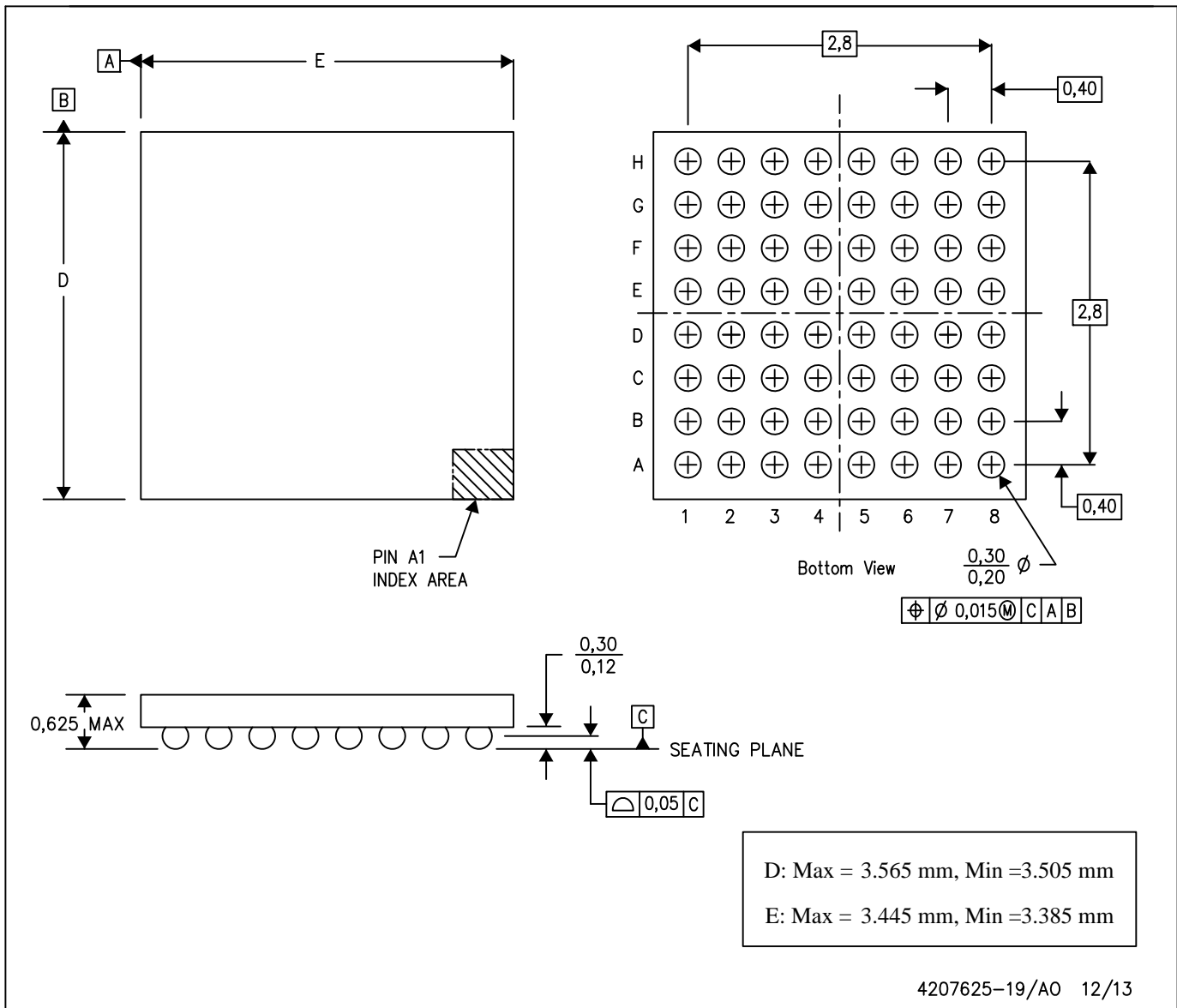

- NOTES: A. All linear dimensions are in millimeters. Dimensioning and tolerancing per ASME Y14.5M-1994.  
 B. This drawing is subject to change without notice.  
 C. NanoFree™ package configuration.

NanoFree is a trademark of Texas Instruments.

## IMPORTANT NOTICE AND DISCLAIMER

TI PROVIDES TECHNICAL AND RELIABILITY DATA (INCLUDING DATASHEETS), DESIGN RESOURCES (INCLUDING REFERENCE DESIGNS), APPLICATION OR OTHER DESIGN ADVICE, WEB TOOLS, SAFETY INFORMATION, AND OTHER RESOURCES "AS IS" AND WITH ALL FAULTS, AND DISCLAIMS ALL WARRANTIES, EXPRESS AND IMPLIED, INCLUDING WITHOUT LIMITATION ANY IMPLIED WARRANTIES OF MERCHANTABILITY, FITNESS FOR A PARTICULAR PURPOSE OR NON-INFRINGEMENT OF THIRD PARTY INTELLECTUAL PROPERTY RIGHTS.

These resources are intended for skilled developers designing with TI products. You are solely responsible for (1) selecting the appropriate TI products for your application, (2) designing, validating and testing your application, and (3) ensuring your application meets applicable standards, and any other safety, security, or other requirements. These resources are subject to change without notice. TI grants you permission to use these resources only for development of an application that uses the TI products described in the resource. Other reproduction and display of these resources is prohibited. No license is granted to any other TI intellectual property right or to any third party intellectual property right. TI disclaims responsibility for, and you will fully indemnify TI and its representatives against, any claims, damages, costs, losses, and liabilities arising out of your use of these resources.

TI's products are provided subject to TI's Terms of Sale ([www.ti.com/legal/termsofsale.html](http://www.ti.com/legal/termsofsale.html)) or other applicable terms available either on [ti.com](http://ti.com) or provided in conjunction with such TI products. TI's provision of these resources does not expand or otherwise alter TI's applicable warranties or warranty disclaimers for TI products.

Mailing Address: Texas Instruments, Post Office Box 655303, Dallas, Texas 75265  
Copyright © 2019, Texas Instruments Incorporated

## Looking for pricing, stock, or lifecycle information?

Click below to explore more details on WIN SOURCE:

 [View MSP430F5229IZQER](#) on WIN SOURCE

 [Texas Instruments](#) Information

## Optimize Your Supply Chain with WIN SOURCE Solutions

-  Global Sourcing Solution
-  Obsolete Management
-  Cost Control Management
-  Shortage Management
-  Alternative Solution
-  Excess Inventory Management