



**THE DATASHEET OF
DAC8830IBDR**





16-Bit, Ultra-Low Power, Voltage-Output Digital-to-Analog Converters

FEATURES

- 16-Bit Resolution
- 2.7 V to 5.5 V Single-Supply Operation
- Very Low Power: 15 μ W for 3 V Power
- High Accuracy, INL: 1 LSB
- Low Noise: 10 nV/\sqrt{Hz}
- Fast Settling: 1.0 μ S
- Fast SPI™ Interface, up to 50 MHz
- Reset to Zero-Code
- Schmitt-Trigger Inputs for Direct Optocoupler Interface
- Industry-Standard Pin Configuration

APPLICATIONS

- Portable Equipment
- Automatic Test Equipment
- Industrial Process Control
- Data Acquisition Systems
- Optical Networking

DESCRIPTION

The DAC8830 and DAC8831 are single, 16-bit, serial-input, voltage-output digital-to-analog converters (DACs) operating from a single 3 V to 5 V power supply. These converters provide excellent linearity (1 LSB INL), low glitch, low noise, and fast settling (1.0 μ S to 1/2 LSB of full-scale output) over the specified temperature range of -40°C to $+85^{\circ}\text{C}$. The output is unbuffered, which reduces the power consumption and the error introduced by the buffer.

These parts feature a standard high-speed (clock up to 50 MHz), 3 V or 5 V SPI serial interface to communicate with a DSP or microprocessor.

The DAC8830 output is 0 V to V_{REF} . However, the DAC8831 provides bipolar output ($\pm V_{REF}$) when working with an external buffer. The DAC8830 and DAC8831 are both reset to zero code after power up. For optimum performance, a set of Kelvin connections to external reference and analog ground input are provided on the DAC8831.

The DAC8830 is available in an SO-8 package, and the DAC8831 in an SO-14 package. Both have industry standard pinouts (see Table 3, the cross-reference table in the Application Information section for details). The DAC8831 is also available in a QFN-14 package.

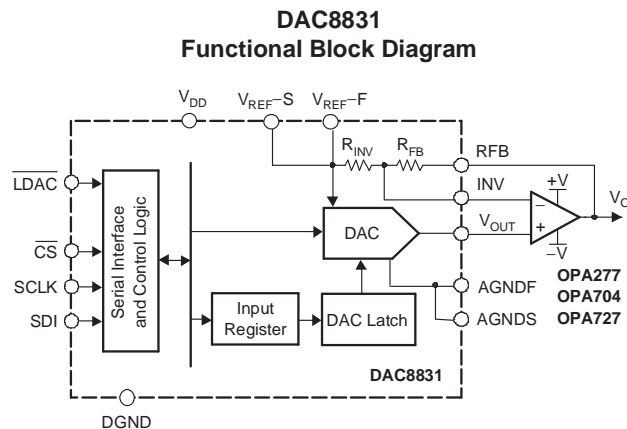
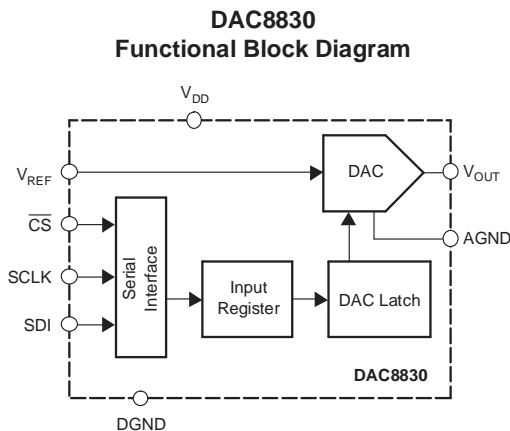

Please be aware that an important notice concerning availability, standard warranty, and use in critical applications of Texas Instruments semiconductor products and disclaimers thereto appears at the end of this data sheet.

SPI, QSPI are trademarks of Motorola, Inc.
Microwire is a trademark of National Semiconductor Corp.
All other trademarks are the property of their respective owners.



This integrated circuit can be damaged by ESD. Texas Instruments recommends that all integrated circuits be handled with appropriate precautions. Failure to observe proper handling and installation procedures can cause damage.

ESD damage can range from subtle performance degradation to complete device failure. Precision integrated circuits may be more susceptible to damage because very small parametric changes could cause the device not to meet its published specifications.

ORDERING INFORMATION⁽¹⁾

| PRODUCT | MINIMUM RELATIVE ACCURACY (LSB) | DIFFERENTIAL NONLINEARITY (LSB) | POWER-ON RESET VALUE | SPECIFIED TEMPERATURE RANGE | PACKAGE MARKING | PACKAGE-LEAD | PACKAGE DESIGNATOR | ORDERING NUMBER | TRANSPORT MEDIA, QUANTITY |
|--------------|---------------------------------|---------------------------------|----------------------|-----------------------------|-----------------|--------------|--------------------|-----------------|---------------------------|
| DAC8830ID | ±4 | ±1 | Zero Code | -40°C to +85°C | 8830I | SO-8 | D | DAC8830ID | Tubes, 75 |
| | | | | | | | | DAC8830IDR | Tape and Reel, 2500 |
| DAC8830IBD | ±2 | ±1 | Zero Code | -40°C to +85°C | 8830I | SO-8 | D | DAC8830IBD | Tubes, 75 |
| | | | | | | | | DAC8830IBDR | Tape and Reel, 2500 |
| DAC8830ICD | ±1 | ±1 | Zero Code | -40°C to +85°C | 8830I | SO-8 | D | DAC8830ICD | Tubes, 75 |
| | | | | | | | | DAC8830ICDR | Tape and Reel, 2500 |
| DAC8831ID | ±4 | ±1 | Zero Code | -40°C to +85°C | 8831I | SO-14 | D | DAC8831ID | Tube, 50 |
| | | | | | | | | DAC8831IDR | Tape and Reel, 2500 |
| DAC8831IBD | ±2 | ±1 | Zero Code | -40°C to +85°C | 8831I | SO-14 | D | DAC8831IBD | Tube, 50 |
| | | | | | | | | DAC8831IBDR | Tape and Reel, 2500 |
| DAC8831ICD | ±1 | ±1 | Zero Code | -40°C to +85°C | 8831I | SO-14 | D | DAC8831ICD | Tube, 50 |
| | | | | | | | | DAC8831ICDR | Tape and Reel, 2500 |
| DAC8831IRGY | ±4 | ±1 | Zero Code | -40°C to +85°C | 8831I | QFN-14 | RGY | DAC8831IRGYT | Tape and Reel, 250 |
| | | | | | | | | DAC8831IRGYR | Tape and Reel, 1000 |
| DAC8831IBRGY | ±2 | ±1 | Zero Code | -40°C to +85°C | 8831I | QFN-14 | RGY | DAC8831IBRGYT | Tape and Reel, 250 |
| | | | | | | | | DAC8831IBRGYR | Tape and Reel, 1000 |
| DAC8831ICRGY | ±1 | ±1 | Zero Code | -40°C to +85°C | 8831I | QFN-14 | RGY | DAC8831ICRGYT | Tape and Reel, 250 |
| | | | | | | | | DAC8831ICRGYR | Tape and Reel, 1000 |

(1) For the most current package and ordering information, see the Package Option Addendum at the end of this data sheet, or see the TI website at www.ti.com.

ABSOLUTE MAXIMUM RATINGS

Over operating free-air temperature range (unless otherwise noted)⁽¹⁾

| | DAC8830, DAC8831 | UNIT |
|---|--|-------------|
| V _{DD} to AGND | -0.3 to +7 | V |
| Digital input voltage to DGND | -0.3 to +V _{DD} + 0.3 | V |
| V _{OUT} to AGND | -0.3 to +V _{DD} + 0.3 | V |
| AGND, AGNDF, AGNDS to DGND | -0.3 to +0.3 | V |
| Operating temperature range | -40 to +85 | °C |
| Storage temperature range | -65 to +150 | °C |
| Junction temperature range (T _J max) | +150 | °C |
| Power dissipation | (T _J max - T _A) / θ _{JA} | W |
| Thermal impedance, θ _{JA} | QFN-14 | 54.9 |
| | SO-8 | 136.9 |
| | SO-14 | 66.6 |

(1) Stresses above those listed under Absolute Maximum Ratings may cause permanent damage to the device. Exposure to absolute maximum conditions for extended periods may affect device reliability.

ELECTRICAL CHARACTERISTICS

All specifications at $T_A = T_{MIN}$ to T_{MAX} , $V_{DD} = +3\text{ V}$ or $V_{DD} = +5\text{ V}$, $V_{REF} = +2.5\text{ V}$ unless otherwise noted.

| PARAMETER | | CONDITIONS | DAC8830, DAC8831 | | | UNIT |
|------------------------------------|--|--|------------------|---------|------------|--------|
| | | | MIN | TYP | MAX | |
| STATIC PERFORMANCE | | | | | | |
| Resolution | | | 16 | | | bits |
| Linearity error | DAC8830ICD, DAC8831ICD, DAC8831ICRGY | | | ±0.5 | ±1 | LSB |
| | DAC8830IBD, DAC8831IBD, DAC8831IBRGY | | | ±0.5 | ±2 | |
| | DAC8830ID, DAC8831ID, DAC8831IRGY | | | ±0.5 | ±4 | |
| Differential linearity error | | All grades | | ±0.5 | ±1 | LSB |
| Gain error | | $T_A = +25^\circ\text{C}$ | | ±1 | ±5 | LSB |
| | | $T_A = -40^\circ\text{C}$ to $+85^\circ\text{C}$ | | | ±7 | |
| Gain drift | | | | ±0.1 | | ppm/°C |
| Zero code error | | $T_A = +25^\circ\text{C}$ | | ±0.25 | ±1 | LSB |
| | | $T_A = -40^\circ\text{C}$ to $+85^\circ\text{C}$ | | | ±2 | |
| Zero code drift | | | | ±0.05 | | ppm/°C |
| OUTPUT CHARACTERISTICS | | | | | | |
| Voltage output ⁽¹⁾ | All devices | Unipolar operation | 0 | | $+V_{REF}$ | V |
| | DAC8831 only | Bipolar operation | $-V_{REF}$ | | $+V_{REF}$ | V |
| Output impedance | | | | 6.25 | | kΩ |
| Settling time | | To 1/2 LSB of FS, $C_L = 10\text{ pF}$ | | 1 | | μs |
| Slew rate ⁽²⁾ | | $C_L = 10\text{ pF}$ | | 25 | | V/μs |
| Digital-to-analog glitch | | 1 LSB change around major carry | | 35 | | nV-s |
| Digital feedthrough ⁽³⁾ | | | | 0.2 | | nV-s |
| Output noise | DAC8830 | $T_A = +25^\circ\text{C}$ | | 10 | | nV/√Hz |
| | DAC8831 | | | 18 | | |
| Power-supply rejection | | V_{DD} varies ±10% | | | ±1 | LSB |
| Bipolar resistor matching | DAC8831 only | R_{FB} / R_{INV} | | 1 | | Ω/Ω |
| | | Ratio error | | ±0.0015 | ±0.0076 | % |
| Bipolar zero error | DAC8831 only | $T_A = +25^\circ\text{C}$ | | ±0.25 | ±5 | LSB |
| | | $T_A = -40^\circ\text{C}$ to $+85^\circ\text{C}$ | | | ±7 | |
| Bipolar zero drift | | DAC8831 only | | ±0.2 | | ppm/°C |

(1) The DAC8830 output is unipolar (0 V to $+V_{REF}$). The DAC8831 output is bipolar ($\pm V_{REF}$) when it connects to an external buffer (see the [Bipolar Output Operation](#) section for details).

(2) Slew rate is measured from 10% to 90% of transition when the output changes from 0 to full-scale.

(3) Digital feedthrough is defined as the impulse injected into the analog output from the digital input. It is measured when the DAC output does not change; \overline{CS} is held high, while SCLK and DIN signals are toggled.

ELECTRICAL CHARACTERISTICS (continued)

All specifications at $T_A = T_{MIN}$ to T_{MAX} , $V_{DD} = +3\text{ V}$ or $V_{DD} = +5\text{ V}$, $V_{REF} = +2.5\text{ V}$ unless otherwise noted.

| PARAMETER | CONDITIONS | DAC8830, DAC8831 | | | UNIT |
|--|--|------------------|-----|----------|--------------------|
| | | MIN | TYP | MAX | |
| REFERENCE INPUT | | | | | |
| Reference input voltage range | | 1.25 | | V_{DD} | V |
| Reference input impedance ⁽⁴⁾ | Unipolar mode | 9 | | | k Ω |
| | Bipolar mode, DAC8831 | 7.5 | | | |
| Reference -3dB bandwidth, BW | Code = FFFFh | | 1.3 | | MHz |
| Reference feedthrough | Code = 0000h, $V_{REF} = 1\text{ V}_{PP}$ at 100 kHz | | 1 | | mV |
| Signal-to-noise ratio, SNR | | | 92 | | dB |
| Reference input capacitance | Code = 0000h | | 75 | | pF |
| | Code = FFFFh | | 120 | | |
| DIGITAL INPUTS | | | | | |
| V_{IL} Input low voltage | $V_{DD} = 2.7\text{ V}$ | | | 0.6 | V |
| | $V_{DD} = 5\text{ V}$ | | | 0.8 | |
| V_{IH} Input high voltage | $V_{DD} = 2.7\text{ V}$ | 2.1 | | | V |
| | $V_{DD} = 5\text{ V}$ | 2.4 | | | |
| Input current | | | | ± 1 | μA |
| Input capacitance | | | | 10 | pF |
| Hysteresis voltage | | | 0.4 | | V |
| POWER SUPPLY | | | | | |
| V_{DD} Power-supply voltage | | 2.7 | | 5.5 | V |
| I_{DD} Power-supply current | $V_{DD} = 3\text{ V}$ | | 5 | 20 | μA |
| | $V_{DD} = 5\text{ V}$ | | 5 | 20 | |
| Power | $V_{DD} = 3\text{ V}$ | | 15 | 60 | μW |
| | $V_{DD} = 5\text{ V}$ | | 25 | 100 | |
| TEMPERATURE RANGE | | | | | |
| Specified performance | | -40 | | +85 | $^{\circ}\text{C}$ |

(4) Reference input resistance is code-dependent, minimum at 8555h.

PIN CONFIGURATIONS (NOT TO SCALE)

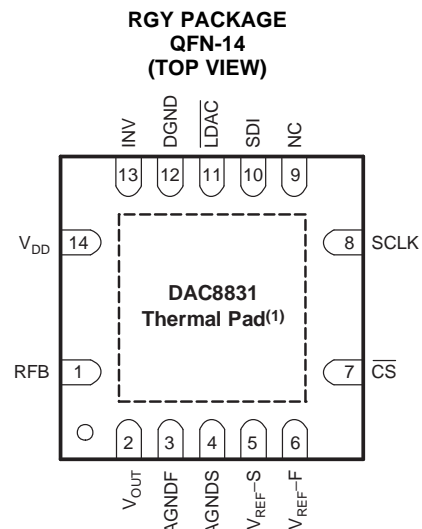
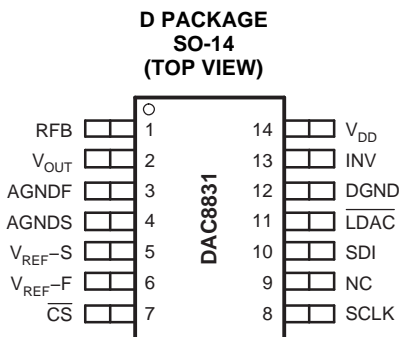
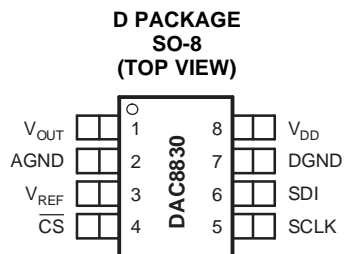

NOTE: (1) Exposed thermal pad in the QFN package must be connected to analog ground.

TERMINAL FUNCTIONS

| TERMINAL NO. | NAME | DESCRIPTION |
|----------------|--------------------|--|
| DAC8830 | | |
| 1 | V _{OUT} | Analog output of DAC |
| 2 | AGND | Analog ground |
| 3 | V _{REF} | Voltage reference input |
| 4 | \overline{CS} | Chip select input (active low). Data are not clocked into SDI unless \overline{CS} is low |
| 5 | SCLK | Serial clock input |
| 6 | SDI | Serial data input. Data are latched into input register on the rising edge of SCLK. |
| 7 | DGND | Digital ground |
| 8 | V _{DD} | Analog power supply, +3 V to +5 V |
| DAC8831 | | |
| 1 | RFB | Feedback resistor. Connect to the output of external operational amplifier in bipolar mode. |
| 2 | V _{OUT} | Analog output of DAC |
| 3 | AGNDF | Analog ground (Force) |
| 4 | AGNDS | Analog ground (Sense) |
| 5 | V _{REF-S} | Voltage reference input (Sense). Connect to external voltage reference |
| 6 | V _{REF-F} | Voltage reference input (Force). Connect to external voltage reference |
| 7 | \overline{CS} | Chip select input (active low). Data are not clocked into SDI unless \overline{CS} is low. |
| 8 | SCLK | Serial clock input. |
| 9 | NC | No internal connection |
| 10 | SDI | Serial data input. Data are latched into input register on the rising edge of SCLK. |
| 11 | \overline{LDAC} | Load DAC control input. Active low. When \overline{LDAC} is Low, the DAC latch is simultaneously updated with the content of the input register. |
| 12 | DGND | Digital ground |
| 13 | INV | Junction point of internal scaling resistors. Connect to external operational amplifier inverting input in bipolar mode. |
| 14 | V _{DD} | Analog power supply, +3 V to +5 V. |

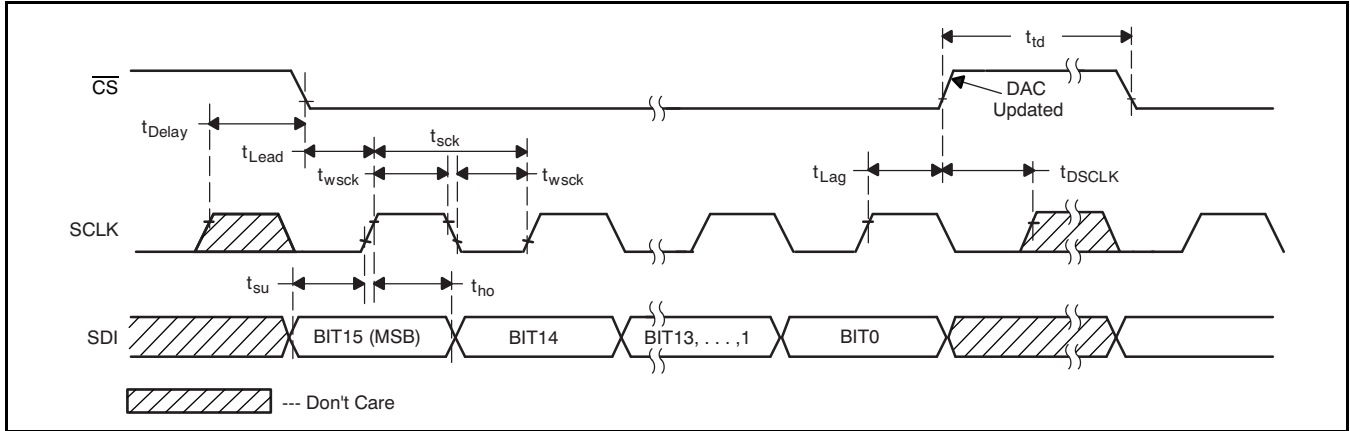

Figure 1. DAC8830 Timing Diagram

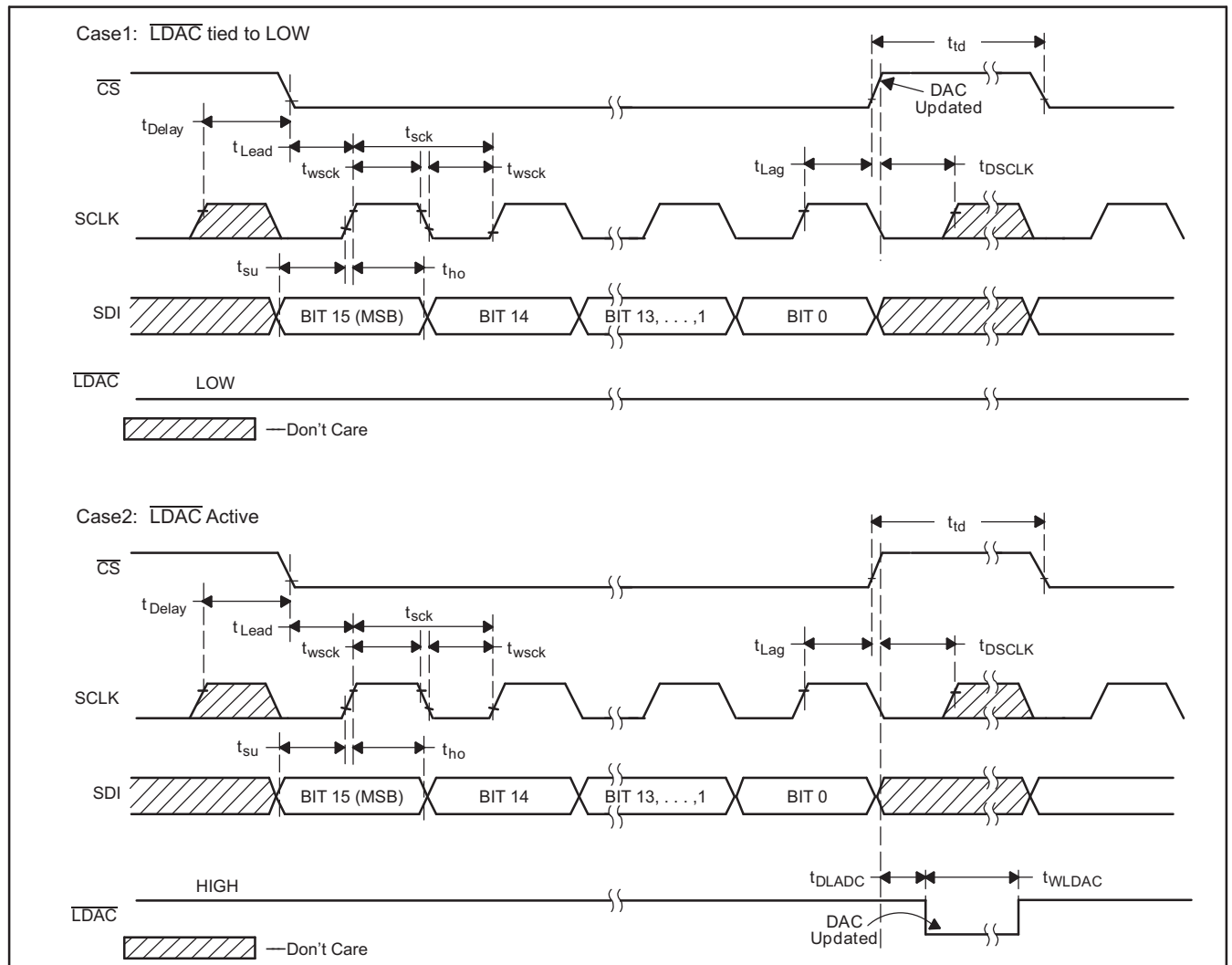

Figure 2. DAC8831 Timing Diagram

TIMING CHARACTERISTICS: $V_{DD} = +5 V^{(1)(2)}$

 At -40°C to $+85^{\circ}\text{C}$, unless otherwise noted.

| PARAMETER | | MIN | MAX | UNIT |
|--------------------|--|-----|-----|---------------|
| t_{sck} | SCLK period | 20 | | ns |
| t_{wsck} | SCLK high or low time | 10 | | ns |
| t_{Delay} | Delay from SCLK high to $\overline{\text{CS}}$ low | 10 | | ns |
| t_{Lead} | $\overline{\text{CS}}$ enable lead time | 10 | | ns |
| t_{Lag} | $\overline{\text{CS}}$ enable lag time | 10 | | ns |
| t_{DSCLK} | Delay from $\overline{\text{CS}}$ high to SCLK high | 10 | | ns |
| t_{td} | $\overline{\text{CS}}$ high between active period | 30 | | ns |
| t_{su} | Data setup time (input) | 10 | | ns |
| t_{ho} | Data hold time (input) | 0 | | ns |
| t_{WLDAC} | $\overline{\text{LDAC}}$ width | 30 | | ns |
| t_{DLDAC} | Delay from $\overline{\text{CS}}$ high to $\overline{\text{LDAC}}$ low | 30 | | ns |
| | V_{DD} high to $\overline{\text{CS}}$ low (power-up delay) | 10 | | μs |

(1) Assured by design. Not production tested.

(2) Sample tested during the initial release and after any redesign or process changes that may affect this parameter.

TIMING CHARACTERISTICS: $V_{DD} = +3 V^{(1)(2)}$

 At -40°C to $+85^{\circ}\text{C}$, unless otherwise noted.

| PARAMETER | | MIN | MAX | UNIT |
|--------------------|--|-----|-----|---------------|
| t_{sck} | SCLK period | 20 | | ns |
| t_{wsck} | SCLK high or low time | 10 | | ns |
| t_{Delay} | Delay from SCLK high to $\overline{\text{CS}}$ low | 10 | | ns |
| t_{Lead} | $\overline{\text{CS}}$ enable lead time | 10 | | ns |
| t_{Lag} | $\overline{\text{CS}}$ enable lag time | 10 | | ns |
| t_{DSCLK} | Delay from $\overline{\text{CS}}$ high to SCLK high | 10 | | ns |
| t_{td} | $\overline{\text{CS}}$ high between active period | 30 | | ns |
| t_{su} | Data setup time (input) | 10 | | ns |
| t_{ho} | Data hold time (input) | 0 | | ns |
| t_{WLDAC} | $\overline{\text{LDAC}}$ width | 30 | | ns |
| t_{DLDAC} | Delay from $\overline{\text{CS}}$ high to $\overline{\text{LDAC}}$ low | 30 | | ns |
| | V_{DD} high to $\overline{\text{CS}}$ low (power-up delay) | 10 | | μs |

(1) Assured by design. Not production tested.

(2) Sample tested during the initial release and after any redesign or process changes that may affect this parameter.

TYPICAL CHARACTERISTICS: $V_{DD} = +5\text{ V}$
At $T_A = +25^\circ\text{C}$ and $V_{REF} = +2.5\text{ V}$, unless otherwise noted.

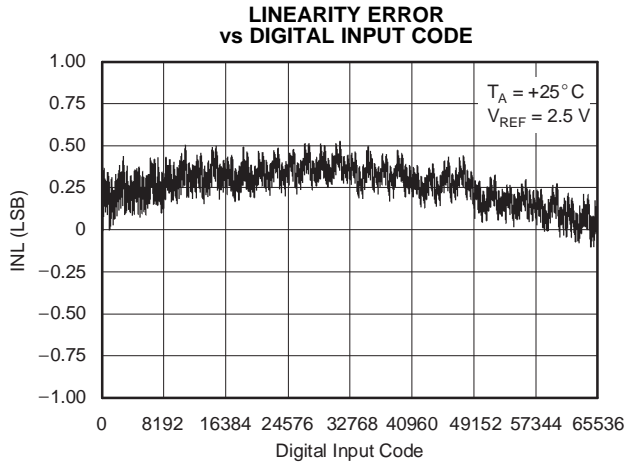

Figure 3.

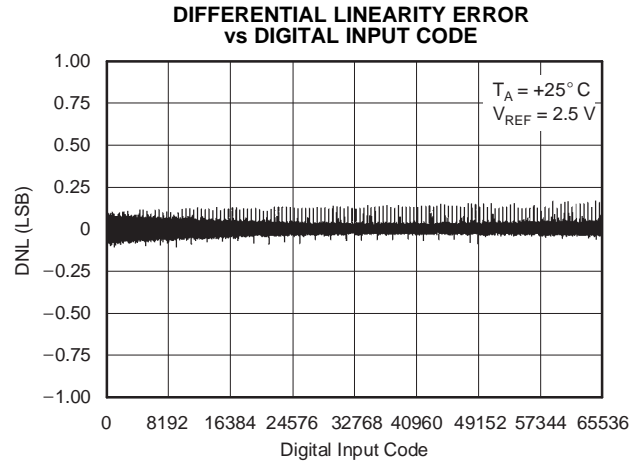

Figure 4.

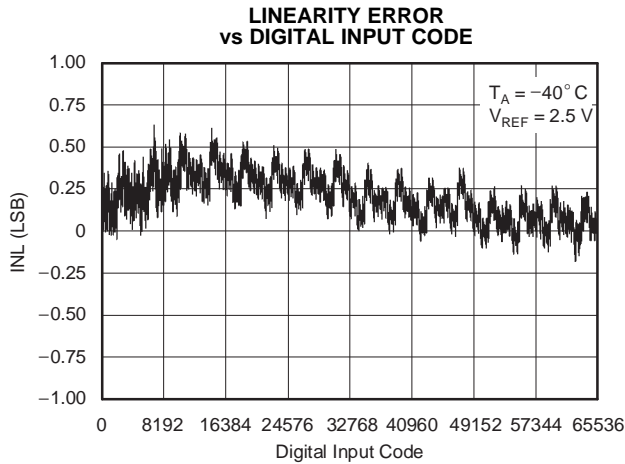

Figure 5.

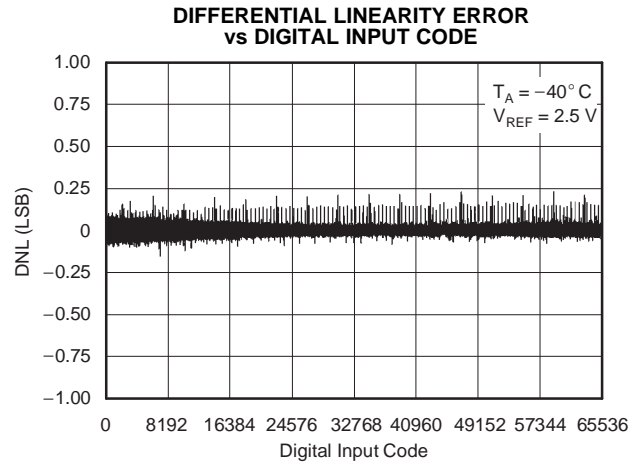

Figure 6.

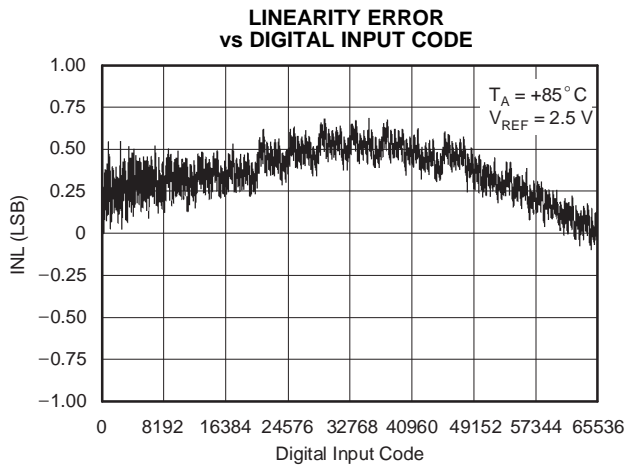

Figure 7.

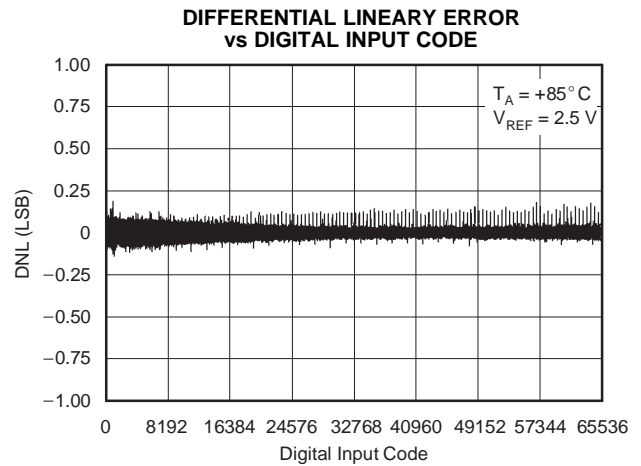

Figure 8.

TYPICAL CHARACTERISTICS: $V_{DD} = +5\text{ V}$ (continued)

At $T_A = +25^\circ\text{C}$ and $V_{REF} = +2.5\text{ V}$, unless otherwise noted.

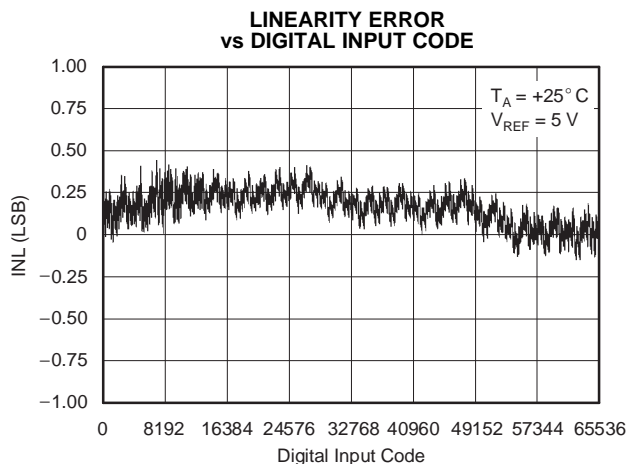

Figure 9.

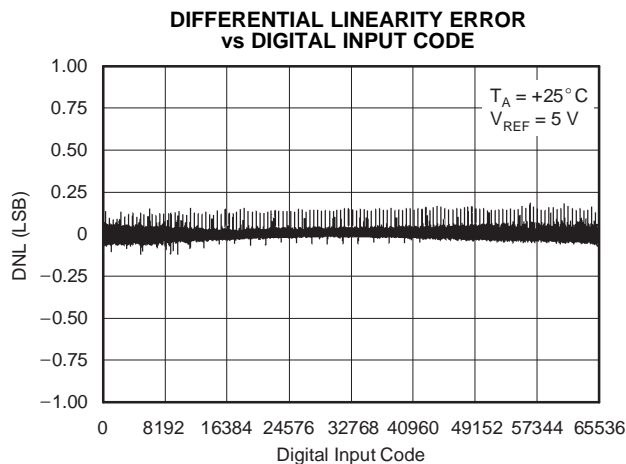

Figure 10.

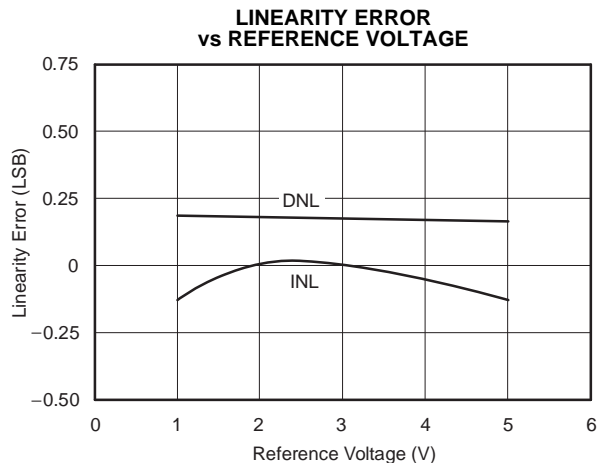

Figure 11.

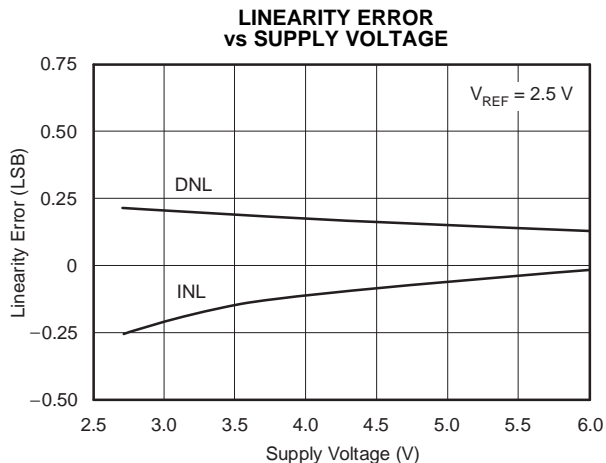

Figure 12.

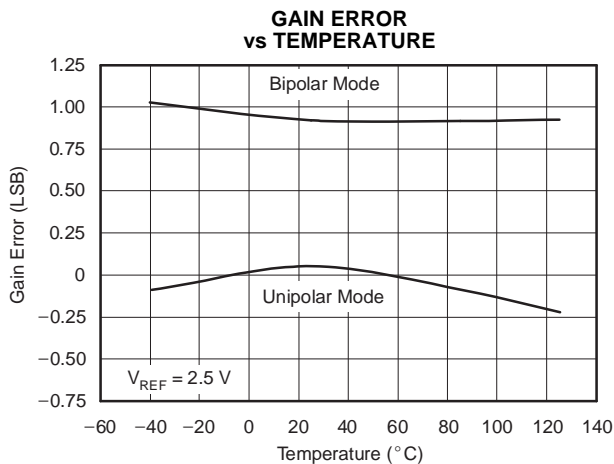

Figure 13.

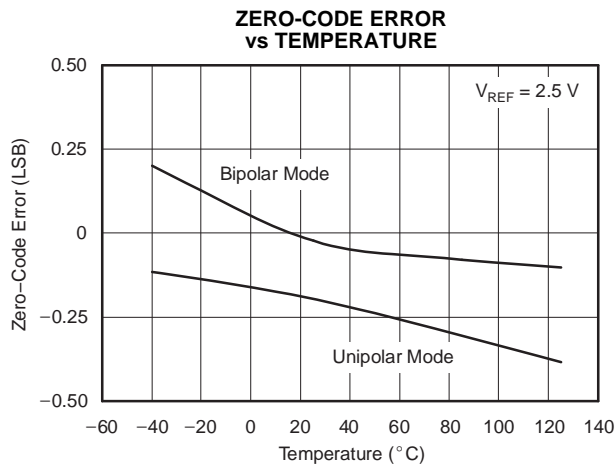

Figure 14.

TYPICAL CHARACTERISTICS: $V_{DD} = +5\text{ V}$ (continued)

At $T_A = +25^\circ\text{C}$ and $V_{REF} = +2.5\text{ V}$, unless otherwise noted.

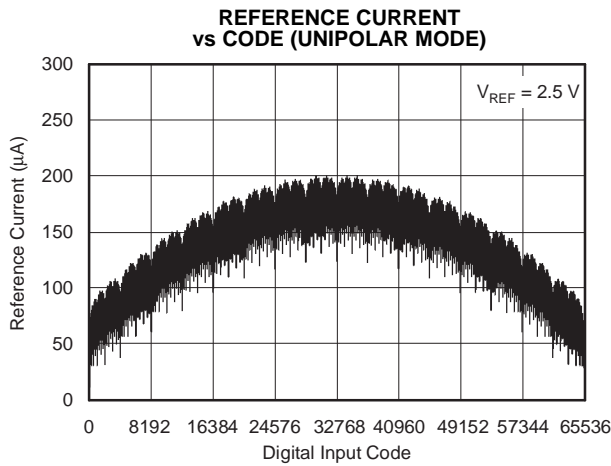

Figure 15.

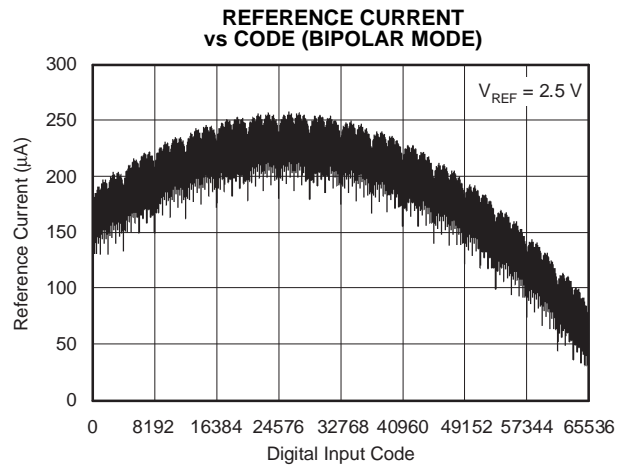

Figure 16.

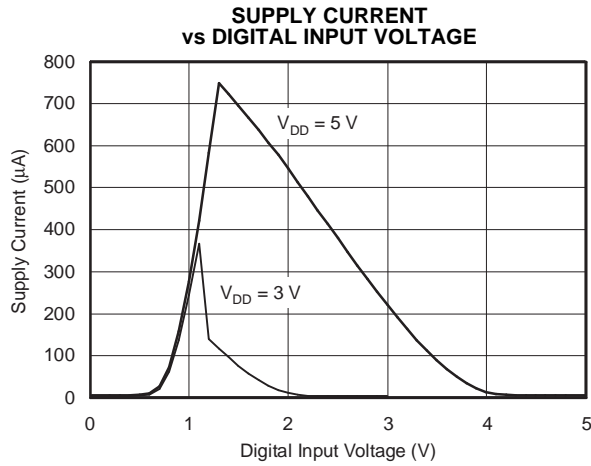

Figure 17.

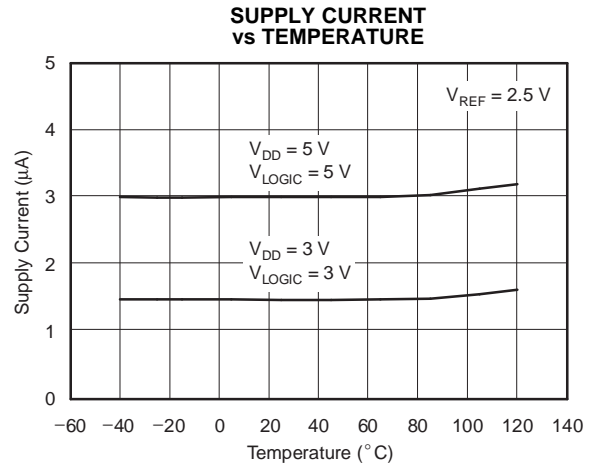

Figure 18.

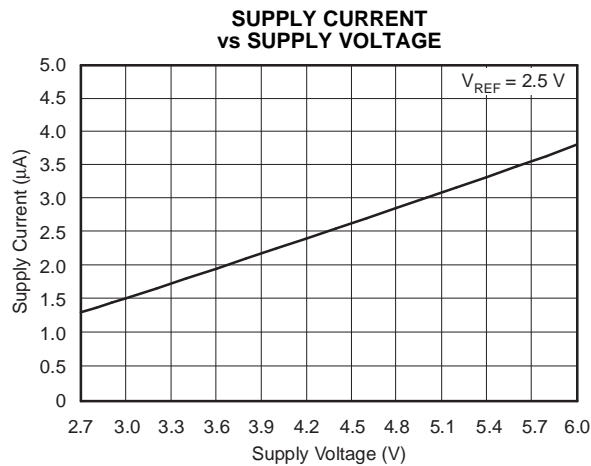

Figure 19.

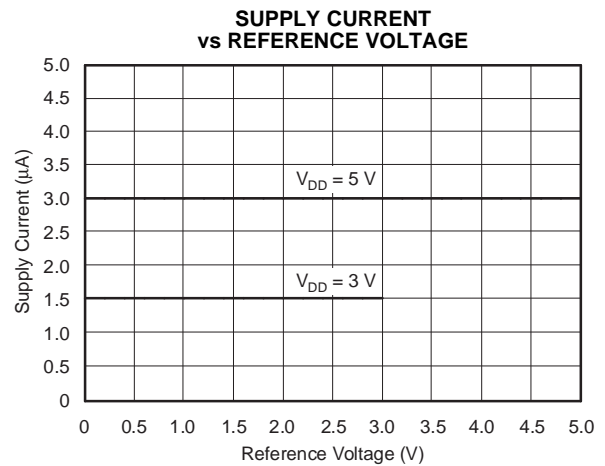

Figure 20.

TYPICAL CHARACTERISTICS: $V_{DD} = +5\text{ V}$ (continued)

At $T_A = +25^\circ\text{C}$ and $V_{REF} = +2.5\text{ V}$, unless otherwise noted.

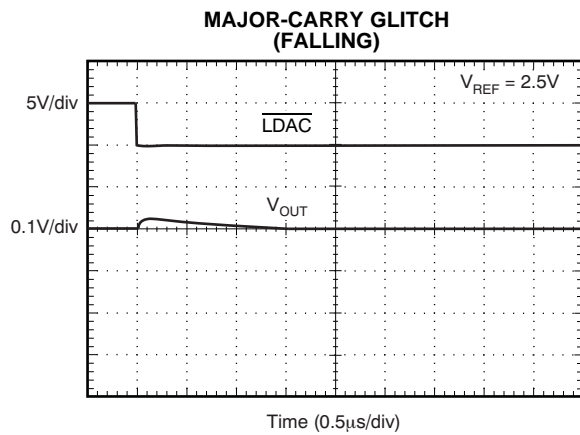

Figure 21.

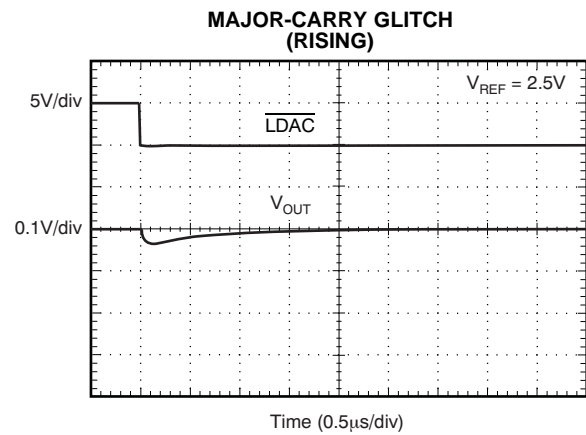

Figure 22.

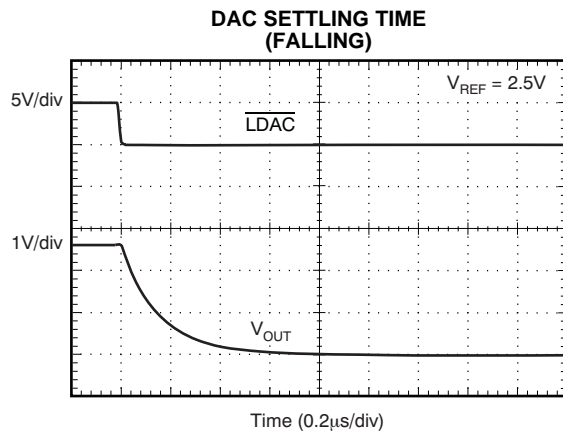

Figure 23.

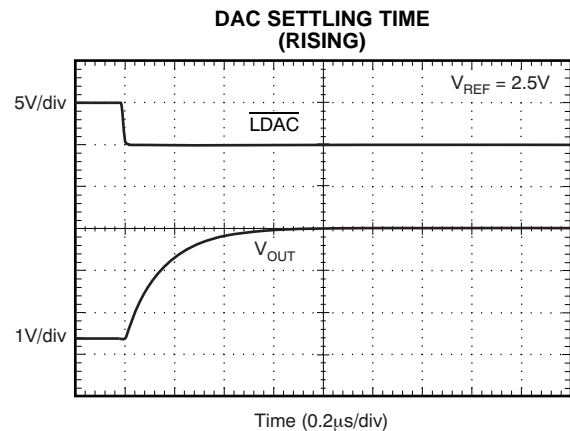

Figure 24.

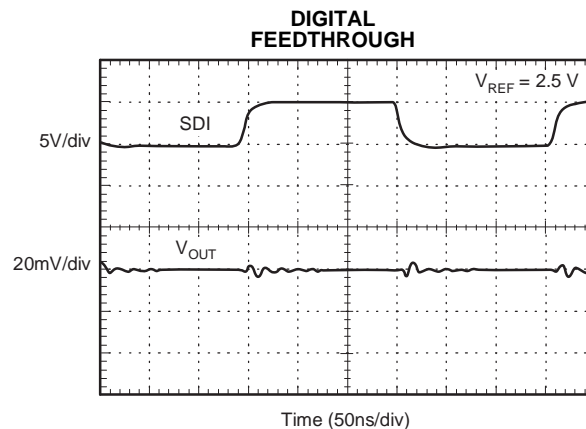

Figure 25.

TYPICAL CHARACTERISTICS: $V_{DD} = +3\text{ V}$
At $T_A = +25^\circ\text{C}$ and $V_{REF} = +2.5\text{ V}$, unless otherwise noted.

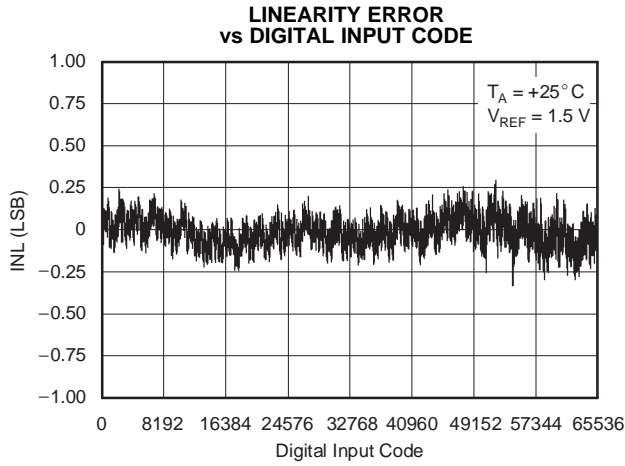

Figure 26.

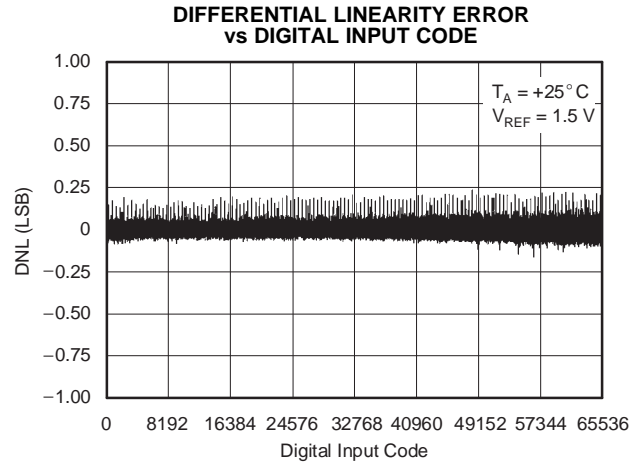

Figure 27.

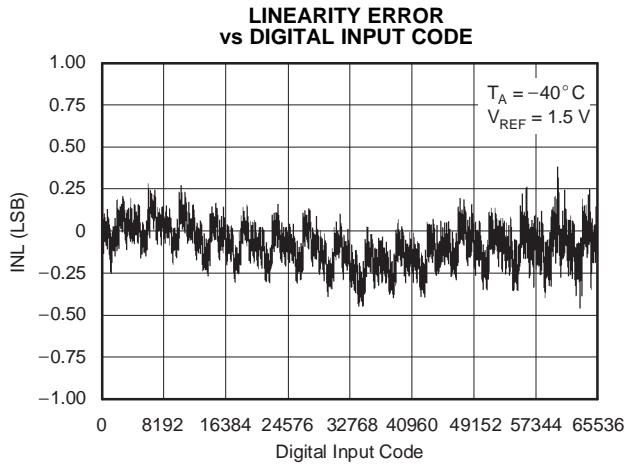

Figure 28.

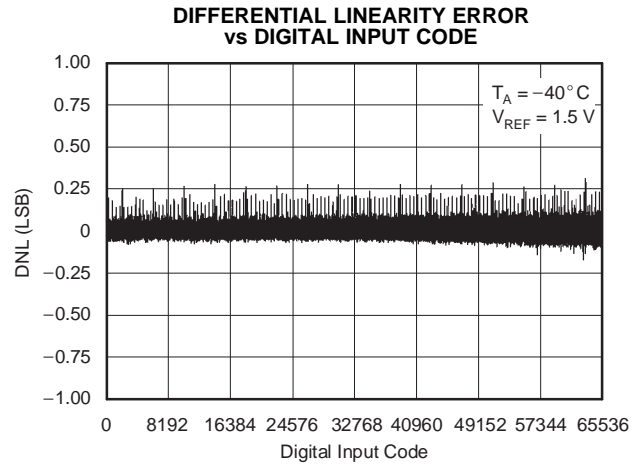

Figure 29.

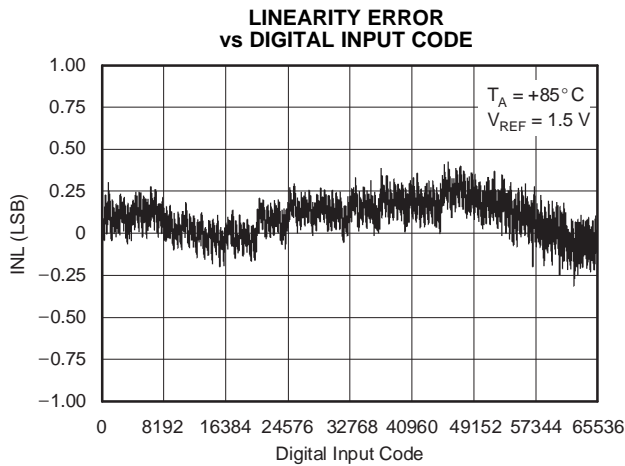

Figure 30.

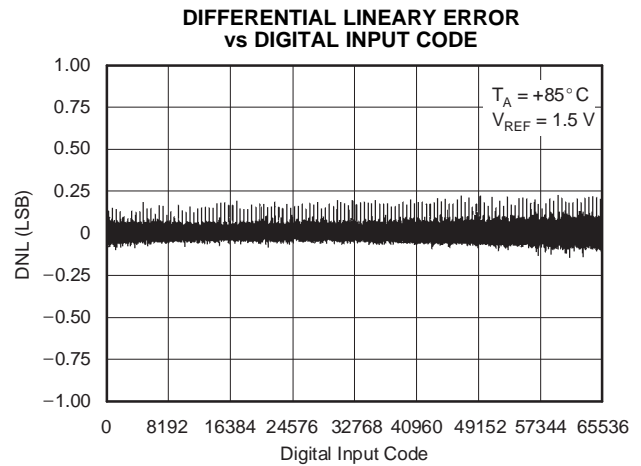

Figure 31.

TYPICAL CHARACTERISTICS: $V_{DD} = +3\text{ V}$ (continued)

At $T_A = +25^\circ\text{C}$ and $V_{REF} = +2.5\text{ V}$, unless otherwise noted.

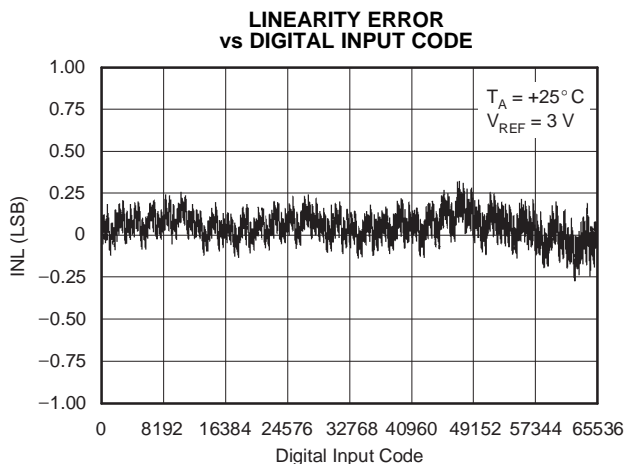

Figure 32.

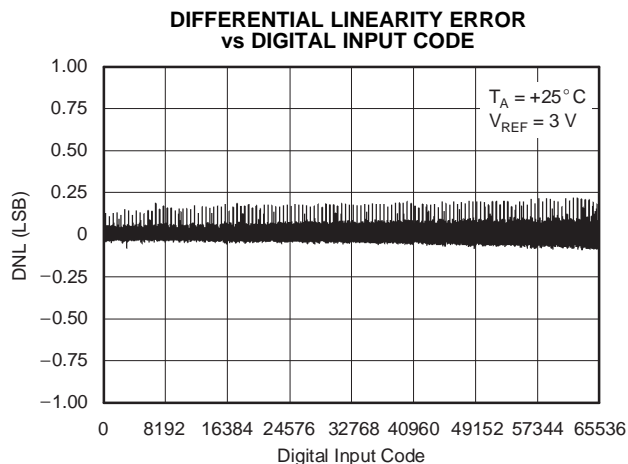

Figure 33.

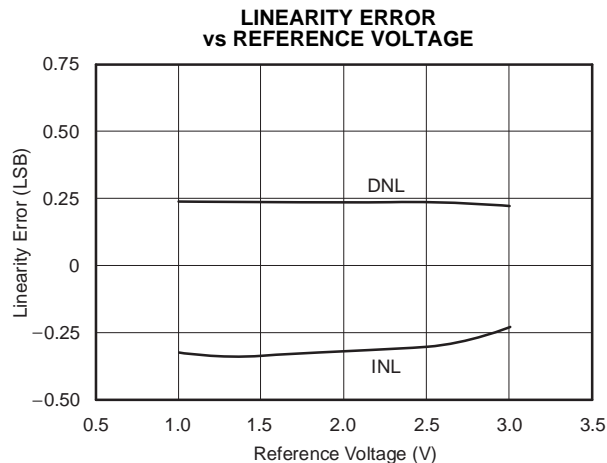

Figure 34.

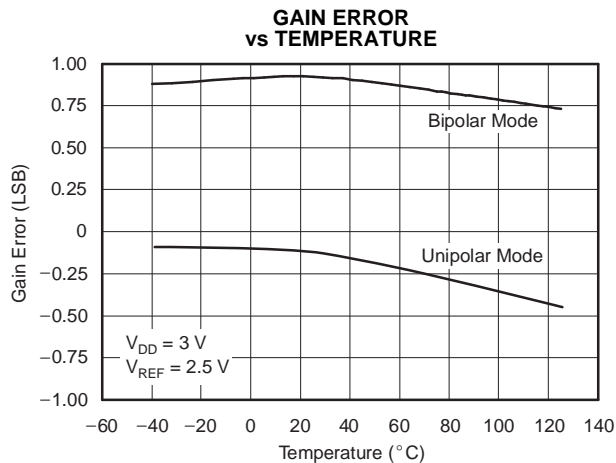

Figure 35.

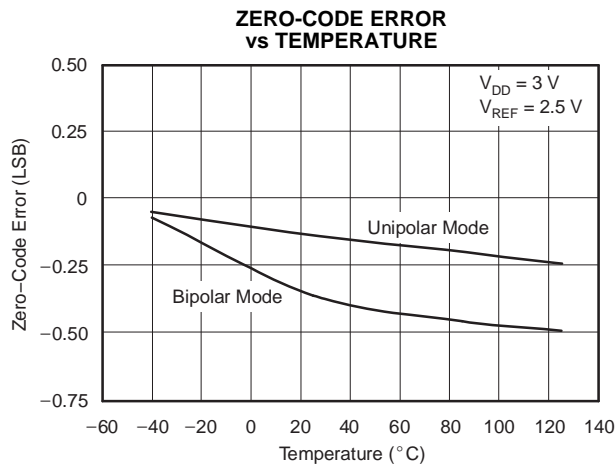

Figure 36.

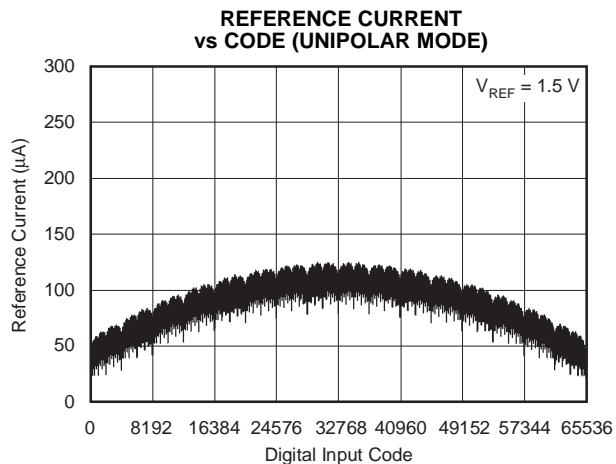

Figure 37.

TYPICAL CHARACTERISTICS: $V_{DD} = +3\text{ V}$ (continued)

At $T_A = +25^\circ\text{C}$ and $V_{REF} = +2.5\text{ V}$, unless otherwise noted.

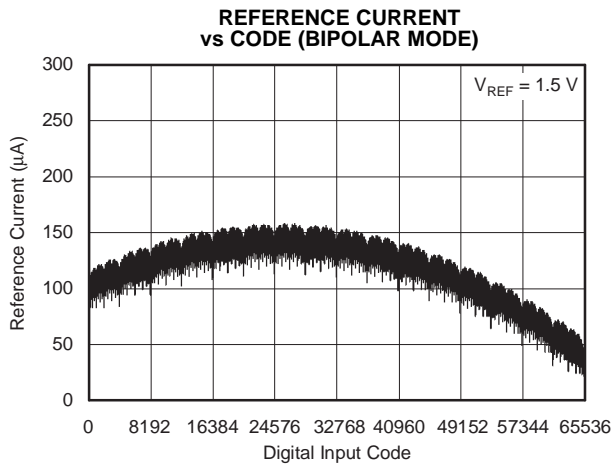

Figure 38.

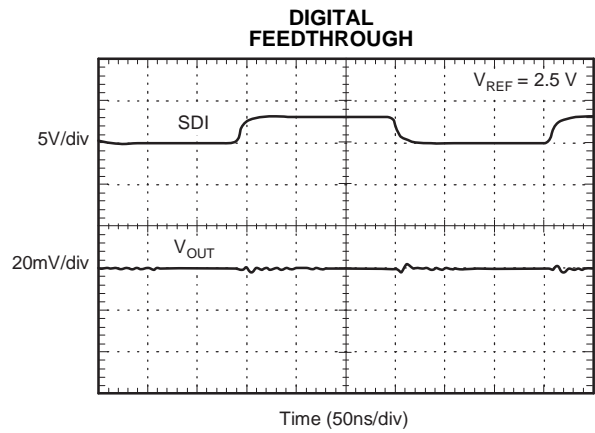

Figure 39.

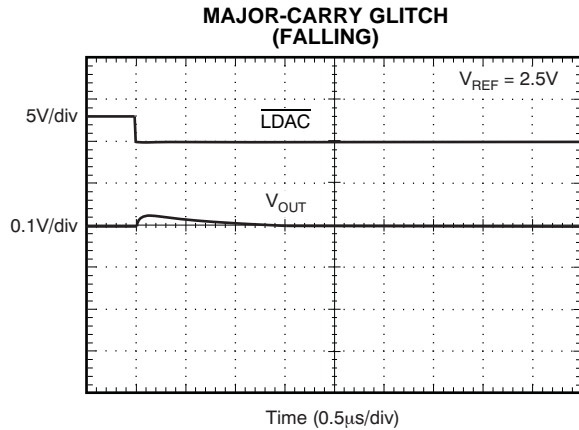

Figure 40.

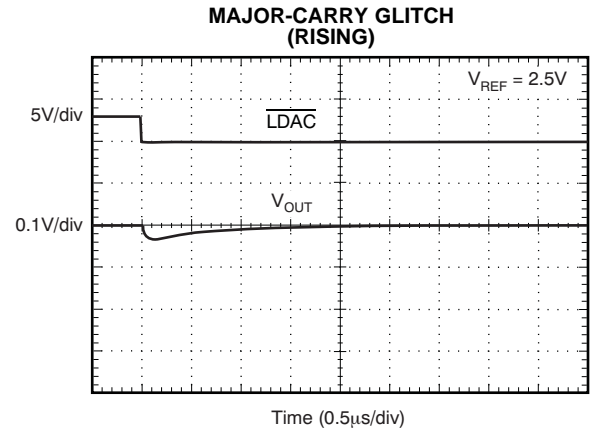

Figure 41.

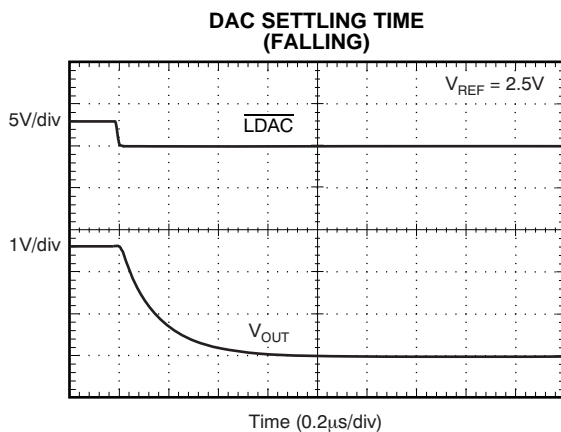

Figure 42.

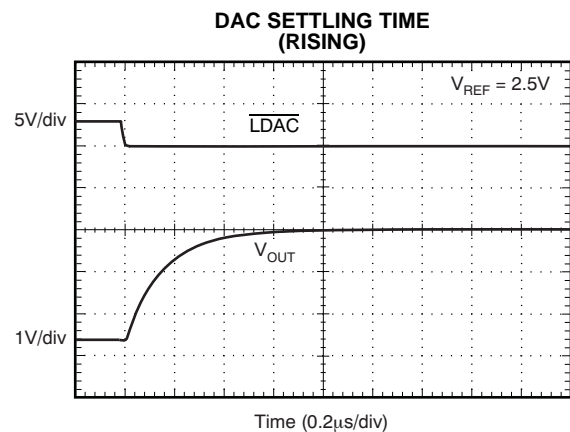

Figure 43.

THEORY OF OPERATION

GENERAL DESCRIPTION

The DAC8830 and DAC8831 are single, 16-bit, serial-input, voltage-output DACs. They operate from a single

supply ranging from 2.7 V to 5 V, and typically consume 5 μ A. Data are written to these devices in a 16-bit word format, via an SPI serial interface. To ensure a known power-up state, these parts are designed with a power-on reset function. The DAC8830 and DAC8831 are reset to zero code. In unipolar mode, the DAC8830 and DAC8831 are reset to 0 V, and in bipolar mode, the DAC8831 is reset to $-V_{REF}$. Kelvin sense connections for the reference and analog ground are included on the DAC8831.

DIGITAL-TO-ANALOG SECTIONS

The DAC architecture for both devices consists of two matched DAC sections and is segmented. A simplified circuit diagram is shown in Figure 44. The four MSBs of the 16-bit data word are decoded to drive 15 switches, E1 to E15. Each of these switches connects one of 15 matched resistors to either AGND or V_{REF} . The remaining 12 bits of the data word drive switches S0 to S11 of a 12-bit voltage mode R-2R ladder network.

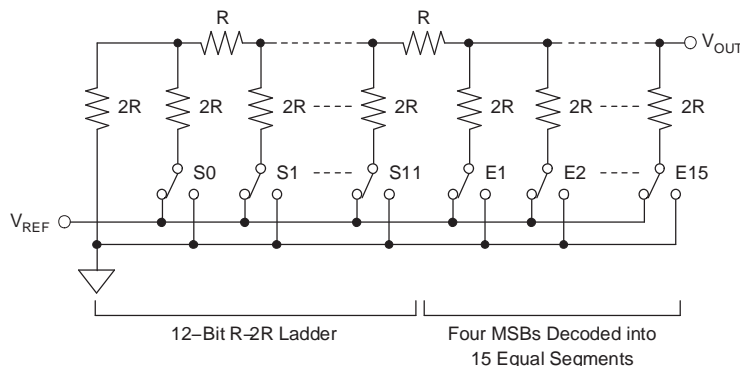

Figure 44. DAC Architecture

OUTPUT RANGE

The output of the DAC is

$$V_{OUT} = (V_{REF} \times Code)/65536.$$

Where *Code* is the decimal data word loaded to the DAC latch.

POWER-ON RESET

Both devices have a power-on reset function to ensure the output is at a known state upon power-up. In the DAC8830 and DAC8831, at power-up, the DAC latch and Input Registers contain all 0s until new data are loaded from the input serial shift register. Therefore, after power-up, the output from pin V_{OUT} of the DAC8830 is 0 V. The output from pin V_{OUT} of the DAC8831 is 0 V in unipolar mode and $-V_{REF}$ in bipolar mode.

However, the serial register of the DAC8830 and DAC8831 is not cleared on power-up, so its contents are undefined. When loading data initially to the device, 16 bits or more should be loaded to prevent erroneous data appearing on the output. If more than 16 bits are loaded, the last 16 are kept; if less than 16 are loaded, bits will remain from the previous word. If the device must be interfaced with data shorter than 16 bits, the data should be padded with 0s at the LSBs.

Serial Interface

The digital interface is a standard 3-wire connection compatible with SPI, QSPI™, Microwire™, and TI DSP interfaces, which can operate at speeds up to 50 M-bits/sec. The data transfer is framed by \overline{CS} , the chip select signal. The DAC works as a bus slave. The bus master generates the synchronize clock, SCLK, and initiates the transmission. When \overline{CS} is high, the DAC is not accessed, and the clock SCLK and serial input data SDI are ignored. The bus master accesses the DAC by driving pin \overline{CS} low. Immediately following the high-to-low transition of \overline{CS} , the serial input data on pin SDI is shifted out from the bus master synchronously on the falling edge of SCLK, and latched on the rising edge of SCLK into the input shift register, MSB first. The low-to-high transition of \overline{CS} transfers the contents of the input shift register to the input register. All data registers are 16-bit. It takes 16 clocks of SCLK to transfer one data word to the parts. To complete a whole data word, \overline{CS} must go high immediately after 16 SCLKs are clocked in. If more than 16 SCLKs are applied during the low state of \overline{CS} , the last 16 bits are transferred to the input register on the rising edge of \overline{CS} . However, if \overline{CS} is not kept low during the entire 16 SCLK cycles, data is corrupted. In this case, reload the DAC with a new 16-bit word.

In the DAC8830, the contents of the input register are transferred into the DAC latch immediately when the input register is loaded, and the DAC output is updated at the same time.

The DAC8831 has an \overline{LDAC} pin allowing the DAC latch to be updated asynchronously by bringing \overline{LDAC} low after \overline{CS} goes high. In this case, \overline{LDAC} must be maintained high while \overline{CS} is low. If \overline{LDAC} is tied permanently low, the DAC latch is updated immediately after the input register is loaded (caused by the low-to-high transition of \overline{CS}).

APPLICATION INFORMATION

Unipolar Output Operation

These DACs are capable of driving unbuffered loads of 60 kΩ. Unbuffered operation results in low supply current (typically 5 μA) and a low offset error. The DAC8830 provides a unipolar output swing ranging from 0 V to V_{REF} . The DAC8831 can be configured to output both unipolar and bipolar voltages. Figure 45 and Figure 46 show a typical unipolar output voltage circuit for each device, respectively. The code table for this mode of operation is shown in Table 1.

Table 1. Unipolar Code

| DAC LATCH CONTENTS | | ANALOG OUTPUT |
|--------------------|----------------|--|
| MSB | LSB | |
| 1111 | 1111 1111 1111 | $V_{REF} \times (65,535/65,536)$ |
| 1000 | 0000 0000 0000 | $V_{REF} \times (32,768/65,536) = 1/2 V_{REF}$ |
| 0000 | 0000 0000 0001 | $V_{REF} \times (1/65,536)$ |
| 0000 | 0000 0000 0000 | 0 V |

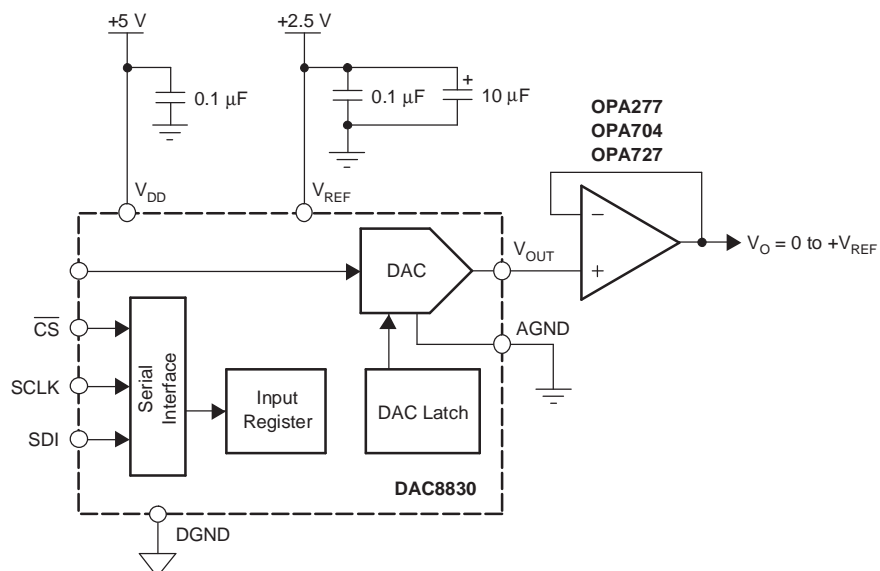

Figure 45. Unipolar Output Mode of DAC8830

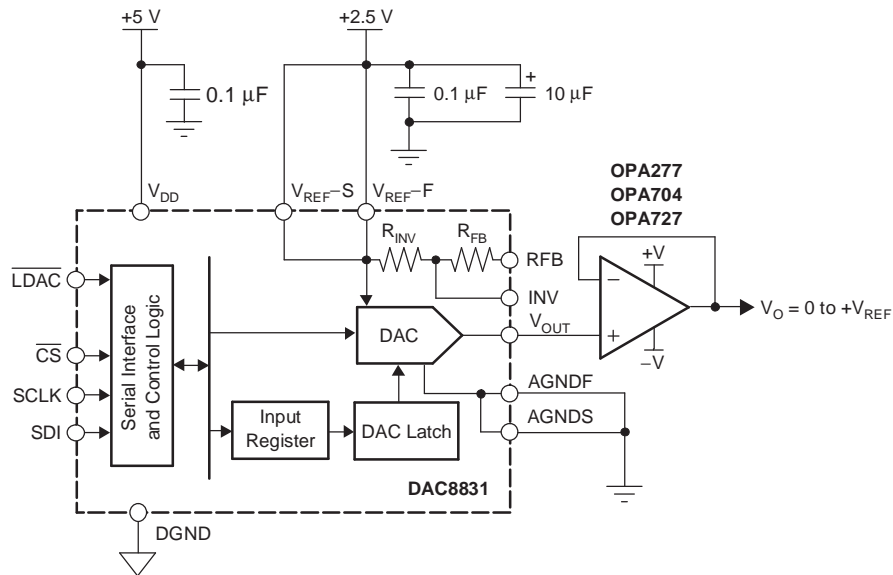

Figure 46. Unipolar Output Mode of DAC8831

Assuming a perfect reference, the worst-case output voltage may be calculated from the following equation:

Unipolar Mode Worst-Case Output

$$V_{\text{OUT_UNI}} = \frac{D}{2^{16}} \times (V_{\text{REF}} + V_{\text{GE}}) + V_{\text{ZSE}} + \text{INL}$$

Where:

$V_{\text{OUT_UNI}}$ = Unipolar mode worst-case output

D = Code loaded to DAC

V_{REF} = Reference voltage applied to part

V_{GE} = Gain error in volts

V_{ZSE} = Zero-scale error in volts

INL = Integral nonlinearity in volts

Bipolar Output Operation

With the aid of an external operational amplifier, the DAC8831 may be configured to provide a bipolar voltage output. A typical circuit of such an operation is shown in Figure 47. The matched bipolar offset resistors R_{FB} and R_{INV} are connected to an external operational amplifier to achieve this bipolar output swing; typically, $R_{FB} = R_{INV} = 28\text{ k}\Omega$.

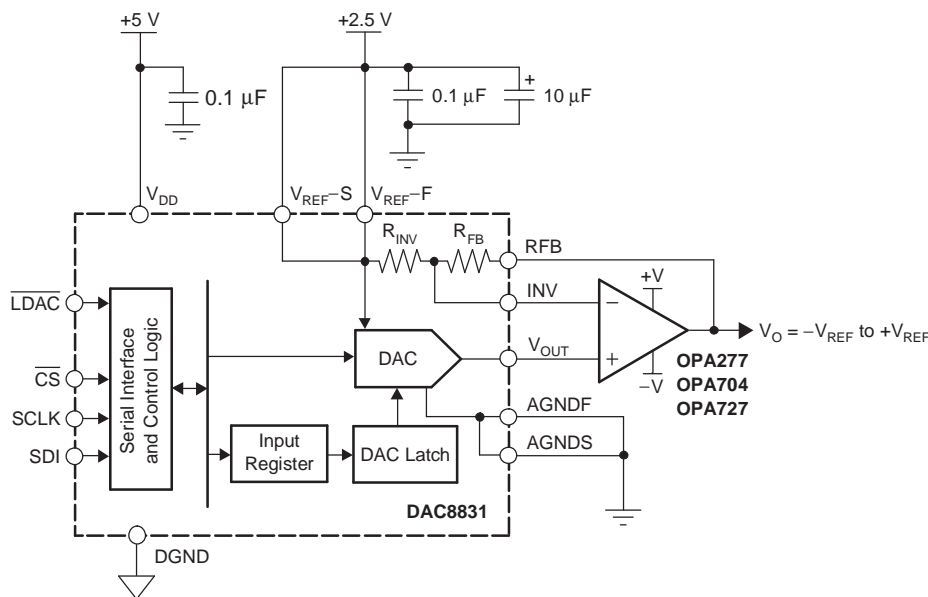

Figure 47. Bipolar Output Mode of DAC8831

Table 2 shows the transfer function for this output operating mode. The DAC8831 also provides a set of Kelvin connections to the analog ground and external reference inputs.

Table 2. Bipolar Code

| DAC LATCH CONTENTS | | ANALOG OUTPUT |
|---------------------|-----|--|
| MSB | LSB | |
| 1111 1111 1111 1111 | | $+V_{REF} \times (32,767/32,768)$ |
| 1000 0000 0000 0001 | | $+V_{REF} \times (1/32,768)$ |
| 1000 0000 0000 0000 | | 0 V |
| 0111 1111 1111 1111 | | $-V_{REF} \times (1/32,768)$ |
| 0000 0000 0000 0000 | | $-V_{REF} \times (32,768/32,768) = -V_{REF}$ |

Assuming a perfect reference, the worst-case output voltage may be calculated from the following equation:

Bipolar Mode Worst-Case Output

$$V_{OUT_BIP} = \frac{\left[(V_{OUT_UNI} + V_{OS}) (2 + RD) - V_{REF}(1 + RD) \right]}{1 + \left(\frac{2 + RD}{A} \right)}$$

Where:

V_{OS} = External operational amplifier input offset voltage

$RD = R_{FB}$ and R_{IN} resistor matching error

A = Operational amplifier open-loop gain

Output Amplifier Selection

For bipolar mode, a precision amplifier should be used, supplied from a dual power supply. This provides the $\pm V_{REF}$ output.

In a single-supply application, selection of a suitable operational amplifier may be more difficult because the output swing of the amplifier does not usually include the negative rail; in this case, AGND. This output swing can result in some degradation of the specified performance unless the application does not use codes near 0.

The selected operational amplifier needs to have low-offset voltage (the DAC LSB is 38 μ V with a 2.5 V reference), eliminating the need for output offset trims. Input bias current should also be low because the bias current multiplied by the DAC output impedance (approximately 6.25 k Ω) adds to the zero-code error.

Rail-to-rail input and output performance are required. For fast settling, the slew rate of the operational amplifier should not impede the settling time of the DAC. Output impedance of the DAC is constant and code-independent, but in order to minimize gain errors the input impedance of the output amplifier should be as high as possible. The amplifier should also have a 3 dB bandwidth of 1 MHz or greater. The amplifier adds another time constant to the system, thus increasing the settling time of the output. A higher 3 dB amplifier bandwidth results in a shorter effective settling time of the combined DAC and amplifier.

Reference and Ground

Since the input impedance is code-dependent, the reference pin should be driven from a low impedance source. The DAC8830 and DAC8831 operate with a voltage reference ranging from 1.25 V to V_{DD} . References below 1.25 V result in reduced accuracy.

The DAC full-scale output voltage is determined by the reference. [Table 1](#) and [Table 2](#) outline the analog output voltage for particular digital codes.

For optimum performance, Kelvin sense connections are provided on the DAC8831. If the application does not require separate force and sense lines, they should be tied together close to the package to minimize voltage drops between the package leads and the internal die.

Power Supply and Reference Bypassing

For accurate high-resolution performance, it is recommended that the reference and supply pins be bypassed with a 10 μ F tantalum capacitor in parallel with a 0.1 μ F ceramic capacitor.

CROSS-REFERENCE

The DAC8830 and DAC8831 have an industry-standard pinout configuration (see [Table 3](#)).

Table 3. Cross-Reference

| MODEL | INL (LSB) | DNL (LSB) | POWER-ON RESET TO | TEMPERATURE RANGE | PACKAGE DESCRIPTION | PACKAGE OPTION | CROSS REFERENCE |
|--------------|-----------|-----------|-------------------|-------------------|--------------------------|----------------|-------------------------|
| DAC8830ICD | ±1 | ±1 | Zero Code | –40°C to +85°C | 8-Lead Small Outline IC | SO-8 | AD5541CR, MAX541AESA |
| DAC8830IBD | ±2 | ±1 | Zero Code | –40°C to +85°C | 8-Lead Small Outline IC | SO-8 | AD5541BR, MAX541BESA |
| DAC8830ID | ±4 | ±1 | Zero Code | –40°C to +85°C | 8-Lead Small Outline IC | SO-8 | AD5541AR, MAX541CESA |
| N/A | ±1 | ±1 | Zero Code | –40°C to +85°C | 8-Lead Plastic DIP | PDIP-8 | MAX541AEP A |
| N/A | ±2 | ±1 | Zero Code | –40°C to +85°C | 8-Lead Plastic DIP | PDIP-8 | MAX541BEP A |
| N/A | ±4 | ±1 | Zero Code | –40°C to +85°C | 8-Lead Plastic DIP | PDIP-8 | MAX541CEP A |
| N/A | ±1 | ±1 | Zero Code | 0°C to +70°C | 8-Lead Small Outline IC | SO-8 | AD5541LR |
| N/A | ±2 | ±1.5 | Zero Code | 0°C to +70°C | 8-Lead Small Outline IC | SO-8 | AD5541JR |
| N/A | ±1 | ±1 | Zero Code | 0°C to +70°C | 8-Lead Plastic DIP | PDIP-8 | MAX541AEP A |
| N/A | ±2 | ±1 | Zero Code | 0°C to +70°C | 8-Lead Plastic DIP | PDIP-8 | MAX541BEP A |
| N/A | ±4 | ±1 | Zero Code | 0°C to +70°C | 8-Lead Plastic DIP | PDIP-8 | MAX541CEP A |
| DAC8831ICD | ±1 | ±1 | Zero Code | –40°C to +85°C | 14-Lead Small Outline IC | SO-14 | AD5542CR, MAX542AESD |
| DAC8831IBD | ±2 | ±1 | Zero Code | –40°C to +85°C | 14-Lead Small Outline IC | SO-14 | AD5542BR, MAX542BESD |
| DAC8831ID | ±4 | ±1 | Zero Code | –40°C to +85°C | 14-Lead Small Outline IC | SO-14 | AD5542AR, MAX542CESD |
| DAC8831ICRGY | ±1 | ±1 | Zero Code | –40°C to +85°C | 14-Lead QFN | QFN-14 | N/A |
| DAC8831IBRGY | ±2 | ±1 | Zero Code | –40°C to +85°C | 14-Lead QFN | QFN-14 | N/A |
| DAC8831IRGY | ±4 | ±1 | Zero Code | –40°C to +85°C | 14-Lead QFN | QFN-14 | N/A |
| N/A | ±1 | ±1 | Zero Code | –40°C to +85°C | 14-Lead Plastic DIP | PDIP-14 | MAX542ACPD |
| N/A | ±2 | ±1 | Zero Code | –40°C to +85°C | 14-Lead Plastic DIP | PDIP-14 | MAX542BCPD |
| N/A | ±4 | ±1 | Zero Code | –40°C to +85°C | 14-Lead Plastic DIP | PDIP-14 | MAX542CCPD |
| N/A | ±1 | ±1 | Zero Code | 0°C to +70°C | 14-Lead Small Outline IC | SO-14 | AD5542LR |
| N/A | ±2 | ±1.5 | Zero Code | 0°C to +70°C | 14-Lead Small Outline IC | SO-14 | AD5542JR |
| N/A | ±1 | ±1 | Zero Code | 0°C to +70°C | 14-Lead Small Outline IC | SO-14 | MAX542AEPD |
| N/A | ±2 | ±1 | Zero Code | 0°C to +70°C | 14-Lead Small Outline IC | SO-14 | MAX542BEPD |
| N/A | ±4 | ±1 | Zero Code | 0°C to +70°C | 14-Lead Small Outline IC | SO-14 | MAX542CEPD |

PACKAGING INFORMATION

| Orderable Device | Status (1) | Package Type | Package Drawing | Pins | Package Qty | Eco Plan (2) | Lead finish/ Ball material (6) | MSL Peak Temp (3) | Op Temp (°C) | Device Marking (4/5) | Samples |
|------------------|---------------|--------------|-----------------|------|-------------|-----------------|--------------------------------------|----------------------|--------------|-------------------------|-------------------------|
| DAC8830IBD | ACTIVE | SOIC | D | 8 | 75 | RoHS & Green | NIPDAU | Level-2-260C-1 YEAR | -40 to 85 | DAC 8830I | Samples |
| DAC8830IBDR | ACTIVE | SOIC | D | 8 | 2500 | RoHS & Green | NIPDAU | Level-2-260C-1 YEAR | -40 to 85 | DAC 8830I | Samples |
| DAC8830ICD | ACTIVE | SOIC | D | 8 | 75 | RoHS & Green | NIPDAU | Level-2-260C-1 YEAR | -40 to 85 | DAC 8830I | Samples |
| DAC8830ICDG4 | ACTIVE | SOIC | D | 8 | 75 | RoHS & Green | NIPDAU | Level-2-260C-1 YEAR | -40 to 85 | DAC 8830I | Samples |
| DAC8830ICDR | ACTIVE | SOIC | D | 8 | 2500 | RoHS & Green | NIPDAU | Level-2-260C-1 YEAR | -40 to 85 | DAC 8830I | Samples |
| DAC8830ID | ACTIVE | SOIC | D | 8 | 75 | RoHS & Green | NIPDAU | Level-2-260C-1 YEAR | -40 to 85 | DAC 8830I | Samples |
| DAC8830IDR | ACTIVE | SOIC | D | 8 | 2500 | RoHS & Green | NIPDAU | Level-2-260C-1 YEAR | -40 to 85 | DAC 8830I | Samples |
| DAC8831IBD | ACTIVE | SOIC | D | 14 | 50 | RoHS & Green | NIPDAU | Level-2-260C-1 YEAR | -40 to 85 | DAC8831I | Samples |
| DAC8831IBDR | ACTIVE | SOIC | D | 14 | 2500 | RoHS & Green | NIPDAU | Level-2-260C-1 YEAR | -40 to 85 | DAC8831I | Samples |
| DAC8831ICD | ACTIVE | SOIC | D | 14 | 50 | RoHS & Green | NIPDAU | Level-2-260C-1 YEAR | -40 to 85 | DAC8831I | Samples |
| DAC8831ICDR | ACTIVE | SOIC | D | 14 | 2500 | RoHS & Green | NIPDAU | Level-2-260C-1 YEAR | -40 to 85 | DAC8831I | Samples |
| DAC8831ICRGYT | ACTIVE | VQFN | RGY | 14 | 250 | RoHS & Green | Call TI | Level-2-260C-1 YEAR | -40 to 85 | BKE | Samples |
| DAC8831ID | ACTIVE | SOIC | D | 14 | 50 | RoHS & Green | NIPDAU | Level-2-260C-1 YEAR | -40 to 85 | DAC8831I | Samples |
| DAC8831IDG4 | ACTIVE | SOIC | D | 14 | 50 | RoHS & Green | NIPDAU | Level-2-260C-1 YEAR | -40 to 85 | DAC8831I | Samples |
| DAC8831IDR | ACTIVE | SOIC | D | 14 | 2500 | RoHS & Green | NIPDAU | Level-2-260C-1 YEAR | -40 to 85 | DAC8831I | Samples |

(1) The marketing status values are defined as follows:

ACTIVE: Product device recommended for new designs.

LIFEBUY: TI has announced that the device will be discontinued, and a lifetime-buy period is in effect.

NRND: Not recommended for new designs. Device is in production to support existing customers, but TI does not recommend using this part in a new design.

PREVIEW: Device has been announced but is not in production. Samples may or may not be available.

OBSELETE: TI has discontinued the production of the device.

(2) **RoHS:** TI defines "RoHS" to mean semiconductor products that are compliant with the current EU RoHS requirements for all 10 RoHS substances, including the requirement that RoHS substance do not exceed 0.1% by weight in homogeneous materials. Where designed to be soldered at high temperatures, "RoHS" products are suitable for use in specified lead-free processes. TI may reference these types of products as "Pb-Free".

RoHS Exempt: TI defines "RoHS Exempt" to mean products that contain lead but are compliant with EU RoHS pursuant to a specific EU RoHS exemption.

Green: TI defines "Green" to mean the content of Chlorine (Cl) and Bromine (Br) based flame retardants meet JS709B low halogen requirements of ≤ 1000 ppm threshold. Antimony trioxide based flame retardants must also meet the ≤ 1000 ppm threshold requirement.

(3) **MSL, Peak Temp.** - The Moisture Sensitivity Level rating according to the JEDEC industry standard classifications, and peak solder temperature.

(4) There may be additional marking, which relates to the logo, the lot trace code information, or the environmental category on the device.

(5) Multiple Device Markings will be inside parentheses. Only one Device Marking contained in parentheses and separated by a "~" will appear on a device. If a line is indented then it is a continuation of the previous line and the two combined represent the entire Device Marking for that device.

(6) **Lead finish/Ball material** - Orderable Devices may have multiple material finish options. Finish options are separated by a vertical ruled line. Lead finish/Ball material values may wrap to two lines if the finish value exceeds the maximum column width.

Important Information and Disclaimer:The information provided on this page represents TI's knowledge and belief as of the date that it is provided. TI bases its knowledge and belief on information provided by third parties, and makes no representation or warranty as to the accuracy of such information. Efforts are underway to better integrate information from third parties. TI has taken and continues to take reasonable steps to provide representative and accurate information but may not have conducted destructive testing or chemical analysis on incoming materials and chemicals. TI and TI suppliers consider certain information to be proprietary, and thus CAS numbers and other limited information may not be available for release.

In no event shall TI's liability arising out of such information exceed the total purchase price of the TI part(s) at issue in this document sold by TI to Customer on an annual basis.

OTHER QUALIFIED VERSIONS OF DAC8830, DAC8831 :

- Enhanced Product : [DAC8830-EP](#), [DAC8831-EP](#)

NOTE: Qualified Version Definitions:

- Enhanced Product - Supports Defense, Aerospace and Medical Applications

TAPE AND REEL INFORMATION

QUADRANT ASSIGNMENTS FOR PIN 1 ORIENTATION IN TAPE

*All dimensions are nominal

| Device | Package Type | Package Drawing | Pins | SPQ | Reel Diameter (mm) | Reel Width W1 (mm) | A0 (mm) | B0 (mm) | K0 (mm) | P1 (mm) | W (mm) | Pin1 Quadrant |
|-------------|--------------|-----------------|------|------|--------------------|--------------------|---------|---------|---------|---------|--------|---------------|
| DAC8830IBDR | SOIC | D | 8 | 2500 | 330.0 | 12.4 | 6.4 | 5.2 | 2.1 | 8.0 | 12.0 | Q1 |
| DAC8830ICDR | SOIC | D | 8 | 2500 | 330.0 | 12.4 | 6.4 | 5.2 | 2.1 | 8.0 | 12.0 | Q1 |
| DAC8830IDR | SOIC | D | 8 | 2500 | 330.0 | 12.4 | 6.4 | 5.2 | 2.1 | 8.0 | 12.0 | Q1 |
| DAC8831IBDR | SOIC | D | 14 | 2500 | 330.0 | 16.4 | 6.5 | 9.0 | 2.1 | 8.0 | 16.0 | Q1 |
| DAC8831ICDR | SOIC | D | 14 | 2500 | 330.0 | 16.4 | 6.5 | 9.0 | 2.1 | 8.0 | 16.0 | Q1 |
| DAC8831IDR | SOIC | D | 14 | 2500 | 330.0 | 16.4 | 6.5 | 9.0 | 2.1 | 8.0 | 16.0 | Q1 |

TAPE AND REEL BOX DIMENSIONS

*All dimensions are nominal

| Device | Package Type | Package Drawing | Pins | SPQ | Length (mm) | Width (mm) | Height (mm) |
|-------------|--------------|-----------------|------|------|-------------|------------|-------------|
| DAC8830IBDR | SOIC | D | 8 | 2500 | 350.0 | 350.0 | 43.0 |
| DAC8830ICDR | SOIC | D | 8 | 2500 | 350.0 | 350.0 | 43.0 |
| DAC8830IDR | SOIC | D | 8 | 2500 | 350.0 | 350.0 | 43.0 |
| DAC8831IBDR | SOIC | D | 14 | 2500 | 350.0 | 350.0 | 43.0 |
| DAC8831ICDR | SOIC | D | 14 | 2500 | 350.0 | 350.0 | 43.0 |
| DAC8831IDR | SOIC | D | 14 | 2500 | 350.0 | 350.0 | 43.0 |

TUBE



*All dimensions are nominal

| Device | Package Name | Package Type | Pins | SPQ | L (mm) | W (mm) | T (μm) | B (mm) |
|--------------|--------------|--------------|------|-----|--------|--------|--------|--------|
| DAC8830IBD | D | SOIC | 8 | 75 | 505.46 | 6.76 | 3810 | 4 |
| DAC8830ICD | D | SOIC | 8 | 75 | 505.46 | 6.76 | 3810 | 4 |
| DAC8830ICDG4 | D | SOIC | 8 | 75 | 505.46 | 6.76 | 3810 | 4 |
| DAC8830ID | D | SOIC | 8 | 75 | 505.46 | 6.76 | 3810 | 4 |
| DAC8831IBD | D | SOIC | 14 | 50 | 505.46 | 6.76 | 3810 | 4 |
| DAC8831ICD | D | SOIC | 14 | 50 | 505.46 | 6.76 | 3810 | 4 |
| DAC8831ID | D | SOIC | 14 | 50 | 505.46 | 6.76 | 3810 | 4 |
| DAC8831IDG4 | D | SOIC | 14 | 50 | 505.46 | 6.76 | 3810 | 4 |

RGY (S-PVQFN-N14)

PLASTIC QUAD FLATPACK NO-LEAD



- NOTES:
- A. All linear dimensions are in millimeters. Dimensioning and tolerancing per ASME Y14.5M-1994.
 - B. This drawing is subject to change without notice.
 - C. QFN (Quad Flatpack No-Lead) package configuration.
 - D. The package thermal pad must be soldered to the board for thermal and mechanical performance.
 - E. See the additional figure in the Product Data Sheet for details regarding the exposed thermal pad features and dimensions.
 -  Pin 1 identifiers are located on both top and bottom of the package and within the zone indicated. The Pin 1 identifiers are either a molded, marked, or metal feature.
 - G. Package complies to JEDEC MO-241 variation BA.

RGY (S-PVQFN-N14)

PLASTIC QUAD FLATPACK NO-LEAD

THERMAL INFORMATION

This package incorporates an exposed thermal pad that is designed to be attached directly to an external heatsink. The thermal pad must be soldered directly to the printed circuit board (PCB). After soldering, the PCB can be used as a heatsink. In addition, through the use of thermal vias, the thermal pad can be attached directly to the appropriate copper plane shown in the electrical schematic for the device, or alternatively, can be attached to a special heatsink structure designed into the PCB. This design optimizes the heat transfer from the integrated circuit (IC).

For information on the Quad Flatpack No-Lead (QFN) package and its advantages, refer to Application Report, QFN/SON PCB Attachment, Texas Instruments Literature No. SLUA271. This document is available at www.ti.com.

The exposed thermal pad dimensions for this package are shown in the following illustration.



Bottom View

Exposed Thermal Pad Dimensions

4206353-2/P 03/14

NOTE: All linear dimensions are in millimeters

RGY (S-PVQFN-N14)

PLASTIC QUAD FLATPACK NO-LEAD



4208122-2/P 03/14

- NOTES:
- All linear dimensions are in millimeters.
 - This drawing is subject to change without notice.
 - Publication IPC-7351 is recommended for alternate designs.
 - This package is designed to be soldered to a thermal pad on the board. Refer to Application Note, Quad Flat-Pack QFN/SON PCB Attachment, Texas Instruments Literature No. SLUA271, and also the Product Data Sheets for specific thermal information, via requirements, and recommended board layout. These documents are available at www.ti.com <<http://www.ti.com>>.
 - Laser cutting apertures with trapezoidal walls and also rounding corners will offer better paste release. Customers should contact their board assembly site for stencil design recommendations. Refer to IPC 7525 for stencil design considerations.
 - Customers should contact their board fabrication site for minimum solder mask web tolerances between signal pads.

D (R-PDSO-G14)

PLASTIC SMALL OUTLINE

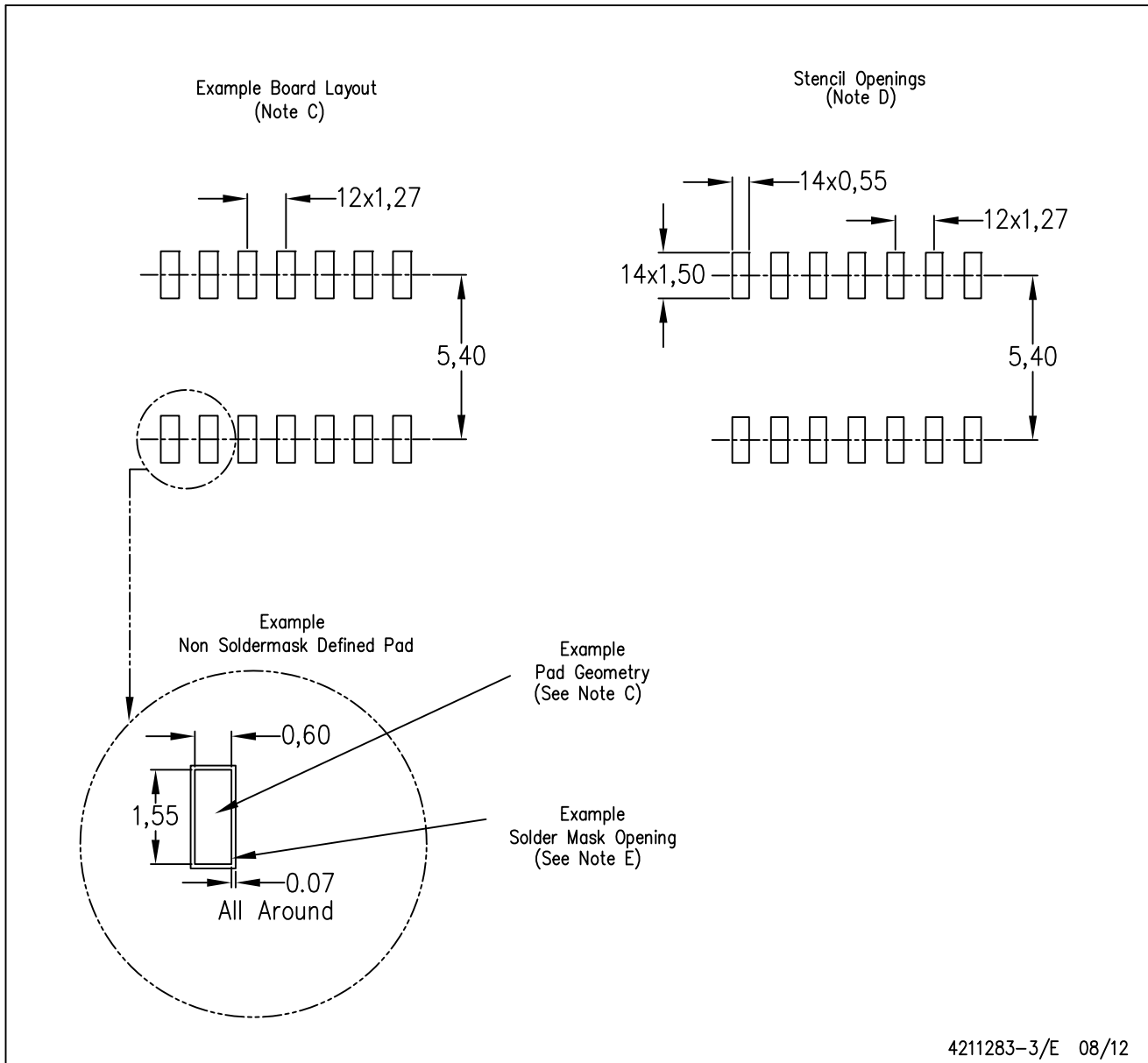

4211283-3/E 08/12

- NOTES:
- All linear dimensions are in millimeters.
 - This drawing is subject to change without notice.
 - Publication IPC-7351 is recommended for alternate designs.
 - Laser cutting apertures with trapezoidal walls and also rounding corners will offer better paste release. Customers should contact their board assembly site for stencil design recommendations. Refer to IPC-7525 for other stencil recommendations.
 - Customers should contact their board fabrication site for solder mask tolerances between and around signal pads.



D0008A

PACKAGE OUTLINE

SOIC - 1.75 mm max height

SMALL OUTLINE INTEGRATED CIRCUIT



4214825/C 02/2019

NOTES:

- Linear dimensions are in inches [millimeters]. Dimensions in parenthesis are for reference only. Controlling dimensions are in inches. Dimensioning and tolerancing per ASME Y14.5M.
- This drawing is subject to change without notice.
- This dimension does not include mold flash, protrusions, or gate burrs. Mold flash, protrusions, or gate burrs shall not exceed .006 [0.15] per side.
- This dimension does not include interlead flash.
- Reference JEDEC registration MS-012, variation AA.

EXAMPLE BOARD LAYOUT

D0008A

SOIC - 1.75 mm max height

SMALL OUTLINE INTEGRATED CIRCUIT



LAND PATTERN EXAMPLE
 EXPOSED METAL SHOWN
 SCALE:8X



SOLDER MASK DETAILS

4214825/C 02/2019

NOTES: (continued)

- 6. Publication IPC-7351 may have alternate designs.
- 7. Solder mask tolerances between and around signal pads can vary based on board fabrication site.

EXAMPLE STENCIL DESIGN

D0008A

SOIC - 1.75 mm max height

SMALL OUTLINE INTEGRATED CIRCUIT



SOLDER PASTE EXAMPLE
BASED ON .005 INCH [0.125 MM] THICK STENCIL
SCALE:8X

4214825/C 02/2019

NOTES: (continued)

8. Laser cutting apertures with trapezoidal walls and rounded corners may offer better paste release. IPC-7525 may have alternate design recommendations.
9. Board assembly site may have different recommendations for stencil design.

IMPORTANT NOTICE AND DISCLAIMER

TI PROVIDES TECHNICAL AND RELIABILITY DATA (INCLUDING DATA SHEETS), DESIGN RESOURCES (INCLUDING REFERENCE DESIGNS), APPLICATION OR OTHER DESIGN ADVICE, WEB TOOLS, SAFETY INFORMATION, AND OTHER RESOURCES "AS IS" AND WITH ALL FAULTS, AND DISCLAIMS ALL WARRANTIES, EXPRESS AND IMPLIED, INCLUDING WITHOUT LIMITATION ANY IMPLIED WARRANTIES OF MERCHANTABILITY, FITNESS FOR A PARTICULAR PURPOSE OR NON-INFRINGEMENT OF THIRD PARTY INTELLECTUAL PROPERTY RIGHTS.

These resources are intended for skilled developers designing with TI products. You are solely responsible for (1) selecting the appropriate TI products for your application, (2) designing, validating and testing your application, and (3) ensuring your application meets applicable standards, and any other safety, security, regulatory or other requirements.

These resources are subject to change without notice. TI grants you permission to use these resources only for development of an application that uses the TI products described in the resource. Other reproduction and display of these resources is prohibited. No license is granted to any other TI intellectual property right or to any third party intellectual property right. TI disclaims responsibility for, and you will fully indemnify TI and its representatives against, any claims, damages, costs, losses, and liabilities arising out of your use of these resources.

TI's products are provided subject to [TI's Terms of Sale](#) or other applicable terms available either on [ti.com](https://www.ti.com) or provided in conjunction with such TI products. TI's provision of these resources does not expand or otherwise alter TI's applicable warranties or warranty disclaimers for TI products.

TI objects to and rejects any additional or different terms you may have proposed.

Mailing Address: Texas Instruments, Post Office Box 655303, Dallas, Texas 75265
Copyright © 2023, Texas Instruments Incorporated

Looking for pricing, stock, or lifecycle information?

Click below to explore more details on WIN SOURCE:

 [View DAC8830IBDR on WIN SOURCE](#)

 [Texas Instruments](#) Information

Optimize Your Supply Chain with WIN SOURCE Solutions

-  Global Sourcing Solution
-  Obsolete Management
-  Cost Control Management
-  Shortage Management
-  Alternative Solution
-  Excess Inventory Management