



**THE DATASHEET OF  
MAX77960EFV06+**



## MAX77960/MAX77961

## 25V<sub>IN</sub>, 3A<sub>OUT</sub> to 6A<sub>OUT</sub>, USB-C Buck-Boost Charger with Integrated FETs for 2S/3S Li-Ion Batteries

### General Description

The MAX77960/MAX77961 are high-performance wide-input 3A (MAX77960)/6A (MAX77961) buck-boost chargers with Smart Power Selector™ and operate as a reverse buck converter without an additional inductor, allowing the ICs to power USB on-the-go (OTG) accessories. The devices integrate low-loss power switches and provide high efficiency, low heat, and fast battery charging in a small solution size. The reverse buck has true load disconnect and is protected by an adjustable output current limit. The devices are highly flexible and programmable through I<sup>2</sup>C configuration or autonomously through resistor configuration.

The battery charger includes the Smart Power Selector to accommodate a wide range of battery sizes and system loads. The Smart Power Selector allows the system to start up smoothly when an input source is available even when the battery is deeply discharged (dead battery) or missing. For battery safety/authentication reasons, the ICs can be configured to keep charging disabled, and allow the DC-DC to switch and regulate the SYS voltage. The system processor can later enable charging using I<sup>2</sup>C commands as appropriate. Alternatively, the ICs can be configured to automatically start charging.

### Applications

- USB Type-C Powered Wide-Input Charging Applications
- 2- and 3-Cell Battery-Powered Devices
- Smartphones, Tablets, and 2-in-1 Laptops
- Medical Devices, Health and Fitness Monitors
- Digital Still, Video, and Action Cameras
- Handheld Computers and Terminals
- Handheld Radios
- Power Tools
- Drones
- Battery Backup
- Wireless Speakers

### Benefits and Features

- 3.5V to 25.4V Input Operating Range, 30V<sub>DC</sub> Withstand
- 97% Peak Efficiency for 2S Battery at 9V<sub>IN</sub>/7.4V<sub>OUT</sub>/1.5A<sub>OUT</sub>
- 97% Peak Efficiency for 3S Battery at 15V<sub>IN</sub>/12.6V<sub>OUT</sub>/2A<sub>OUT</sub>
- MAX77960
  - 100mA to 3.15A Programmable Input Current Limit
  - 100mA to 3A Programmable Constant Current Charge
- MAX77961
  - 100mA to 6.3A Programmable Input Current Limit
  - 100mA to 6A Programmable Constant Current Charge
- Remote Differential Voltage Sensing
- 600kHz Switching Frequency
- System Instant On with Smart Power Selector Power Path
- Charge Safety Timer
- Die Temperature Regulation with Thermal Foldback Loop
- Input Power Management with Adaptive Input Current Limit (AICL) and Input Voltage Regulation
- 10mΩ BATT to SYS Switch, Up to 10A Overcurrent Threshold
- Reverse Buck Mode 5.1V/3A to Support USB OTG
- JEITA Compliant with NTC Thermistor Monitor
- I<sup>2</sup>C or Resistor Programmable
- 4mm x 4mm, 30-Lead FC2QFN

Analog Devices is in the process of updating documentation to provide culturally appropriate terminology and language. This is a process with a wide scope and will be phased in as quickly as possible. Thank you for your patience. Smart Power Selector is a trademark of Maxim Integrated Products, Inc.

[Ordering Information](#) appears at end of data sheet.

19-100909; Rev 1; 6/24

© 2024 Analog Devices, Inc. All rights reserved. Trademarks and registered trademarks are the property of their respective owners.

One Analog Way, Wilmington, MA 01887 U.S.A. | Tel: 781.329.4700 | © 2024 Analog Devices, Inc. All rights reserved.

Simplified Block Diagram

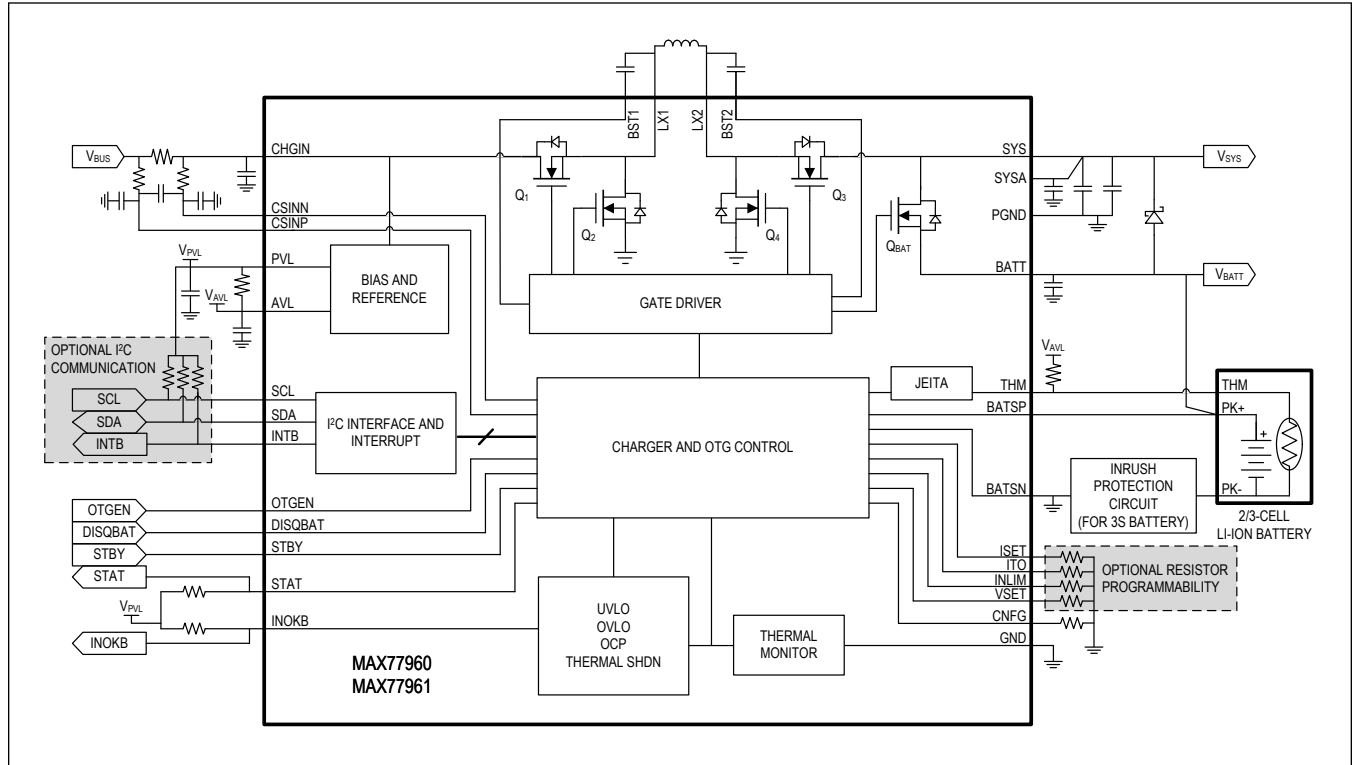

**TABLE OF CONTENTS**

General Description . . . . .	1
Applications . . . . .	1
Benefits and Features . . . . .	1
Simplified Block Diagram . . . . .	2
Absolute Maximum Ratings . . . . .	8
Package Information . . . . .	8
30-Lead FC2QFN . . . . .	8
Electrical Characteristics . . . . .	9
Typical Operating Characteristics . . . . .	19
Pin Configuration . . . . .	20
MAX77960/MAX77961 . . . . .	20
Pin Description . . . . .	21
Detailed Description . . . . .	23
Charger Configuration . . . . .	23
Device Configuration Input (CNFG) . . . . .	23
CHGIN Standby Input (STBY) . . . . .	23
Battery to SYS Q <sub>BAT</sub> Disable Input (DISQBAT) . . . . .	23
Q <sub>BAT</sub> and DC-DC Control—Configuration Table . . . . .	23
Thermistor Input (THM) . . . . .	24
Autonomous Charging . . . . .	25
Charger Input Current Limit Setting Input (INLIM) . . . . .	26
Fast-Charge Current Setting Input (ISET) . . . . .	26
Top-Off Current Setting Input (ITO) . . . . .	27
Charge Termination Voltage Setting Input (VSET) . . . . .	27
Switch Mode Charger . . . . .	28
Smart Power Selector (SPS) . . . . .	28
CHGIN Regulation Voltage . . . . .	29
SYS Regulation Voltage . . . . .	29
Power States . . . . .	30
Powering Up with the Charger Disabled by Default . . . . .	30
Input Validation . . . . .	30
Adaptive Input Current Limit (AICL) and Input Voltage Regulation . . . . .	31
Input Self-Discharge . . . . .	31
System Self-Discharge with No Power . . . . .	31
Charger States . . . . .	31
No Input Power or Charger Disabled Idle State . . . . .	33
Precharge State . . . . .	34
Trickle Charge State . . . . .	34
Fast-Charge Constant Current State . . . . .	34

**TABLE OF CONTENTS (CONTINUED)**

Fast-Charge Constant Voltage State . . . . .	35
Top-Off State . . . . .	35
Done State . . . . .	36
Timer Fault State . . . . .	36
Watchdog Timer Suspend State . . . . .	36
Thermal Shutdown State . . . . .	36
Thermal Management . . . . .	37
Thermal Foldback . . . . .	37
JEITA Compliance . . . . .	38
Thermal Shutdown . . . . .	39
Factory Ship Mode . . . . .	39
Minimum System Voltage . . . . .	39
Battery Differential Voltage Sense (BATSP, BATSN) . . . . .	39
Battery Overcurrent Alert . . . . .	39
Charger Interrupt Debounce Time . . . . .	40
Input Power-OK/OTG Power-OK Output (INOKB) . . . . .	40
Charge Status Output (STAT) . . . . .	40
Reverse Buck Mode (OTG) . . . . .	41
OTG Enable (OTGEN) . . . . .	41
Analog Low-Noise Power Input (AVL) . . . . .	42
Low-Side Gate Driver Power Supply (PVL) . . . . .	42
System Faults . . . . .	42
Register Types and Reset Conditions . . . . .	42
Charger Register Write Protection . . . . .	42
Interrupt Output (INTB) . . . . .	42
I <sup>2</sup> C Serial Interface . . . . .	42
System Configuration . . . . .	43
Bit Transfer . . . . .	43
START and STOP Conditions . . . . .	43
Acknowledge . . . . .	44
Slave Address . . . . .	44
Clock Stretching . . . . .	44
General Call Address . . . . .	44
Communication Speed . . . . .	44
Communication Protocols . . . . .	45
Writing to a Single Register . . . . .	45
Writing to Sequential Registers . . . . .	46
Writing Multiple Bytes using Register-Data Pairs . . . . .	47
Reading from a Single Register . . . . .	48

---

**TABLE OF CONTENTS (CONTINUED)**

---

Reading from Sequential Registers . . . . .	49
Register Map . . . . .	50
FUNC . . . . .	50
Register Details . . . . .	51
Applications Information . . . . .	73
Inductor Selection . . . . .	73
CHGIN Capacitor Selection . . . . .	73
SYS Capacitor Selection . . . . .	73
Battery Insertion Protection . . . . .	74
PCB Layout Guidelines . . . . .	76
Typical Application Circuits . . . . .	78
Wide-Input I <sup>2</sup> C Programmable Charger . . . . .	78
Wide-Input I <sup>2</sup> C Programmable Charger with Charger Disabled . . . . .	79
Wide-Input Autonomous Charger . . . . .	80
Ordering Information . . . . .	81
Revision History . . . . .	82

---

**LIST OF FIGURES**

---

Figure 1. Li Battery Charge Profile . . . . .	32
Figure 2. Charger State Diagram . . . . .	33
Figure 3. Charge Currents vs. Junction Temperature . . . . .	37
Figure 4. JEITA Compliance . . . . .	38
Figure 5. B2SOVRC . . . . .	40
Figure 6. Functional Logic Diagram for Communications Controller . . . . .	43
Figure 7. I <sup>2</sup> C Bit Transfer . . . . .	43
Figure 8. I <sup>2</sup> C Start Stop . . . . .	44
Figure 9. Writing to a Single Register . . . . .	45
Figure 10. Writing to Sequential Registers . . . . .	46
Figure 11. Writing to Multiple Registers with “Multiple Byte Register-Data Pairs” Protocol . . . . .	47
Figure 12. Reading from a Single Register . . . . .	48
Figure 13. Reading from Sequential Registers . . . . .	49
Figure 14. Battery Insertion Protection with 2S Battery . . . . .	75
Figure 15. Battery Insertion Protection with 3S Battery . . . . .	76
Figure 16. PCB Layout Example . . . . .	77

---

**LIST OF TABLES**

---

Table 1. CNFG Program Options Lookup Table . . . . .	23
Table 2. Q <sub>BAT</sub> and DC-DC Control Configuration Table . . . . .	23
Table 3. Trip Temperatures for Different Thermistors . . . . .	25
Table 4. INLIM, ITO, ISET, and VSET Pin Connections for Autonomous Charging . . . . .	26
Table 5. INLIM Program Options Lookup Table . . . . .	26
Table 6. ISET Program Options Lookup Table . . . . .	26
Table 7. ITO Program Options Lookup Table . . . . .	27
Table 8. VSET Program Options Lookup Table . . . . .	28
Table 9. List of Charger Interrupt Debounce Time . . . . .	40
Table 10. Charge Status Indicator by STAT . . . . .	41
Table 11. Recommended Inductance for Combinations of Switching Frequency and Maximum Nominal CHGIN Voltage . . . . .	73
Table 12. Suggested Inductors . . . . .	73
Table 13. Suggested CHGIN Capacitors . . . . .	73
Table 14. Suggested SYS Capacitors . . . . .	74

**Absolute Maximum Ratings**

CHGIN to GND.....	-0.3V to +30.0V	PVL, AVL, ISET, VSET, INLIM, ITO, CNFG, THM to GND .	-0.3V
CSINP, CSINN to CHGIN.....	-0.3V to +0.3V		to +2.2V
LX1 to PGND.....	-0.3V to +30.0V	AVL to PVL .....	-0.3V to +0.3V
LX2 to PGND.....	-0.3V to +16.0V	DISQBAT, OTGEN, STBY, STAT, INOKB, INTB, SDA, SCL to	
BST1 to PVL.....	-0.3V to +30.0V	GND .....	-0.3V to +6.0V
BST2 to PVL.....	-0.3V to +16.0V	CHGIN Continuous Current .....	6.5A <sub>RMS</sub>
BST_ to LX .....	-0.3V to +2.2V	LX_, PGND Continuous Current .....	6.5A <sub>RMS</sub>
SYS, SYSA to GND.....	-0.3V to +16.0V	SYS, BATT Continuous Current .....	10.0A <sub>RMS</sub>
BATT to GND .....	-0.3V to +16.0V	Continuous Power Dissipation (Multilayer Board) (T <sub>A</sub> = +70°C,	
SYS to BATT .....	-0.3V to +16.0V	derate 40.37mW/°C above +70°C.) .....	3229.71mW
BATSP to GND .....	-0.3V to V <sub>BATT</sub> + 0.3V	Operating Temperature Range .....	-40°C to +85°C
BATSN, PGND to GND .....	-0.3V to +0.3V	Storage Temperature Range .....	-65°C to +150°C

Stresses beyond those listed under "Absolute Maximum Ratings" may cause permanent damage to the device. These are stress ratings only, and functional operation of the device at these or any other conditions beyond those indicated in the operational sections of the specifications is not implied. Exposure to absolute maximum rating conditions for extended periods may affect device reliability.

**Package Information**

**30-Lead FC2QFN**

Package Code	F304A4F+1
Outline Number	<a href="#">21-100278</a>
Land Pattern Number	<a href="#">90-100100</a>
<b>Thermal Resistance, Four-Layer Board:</b>	
Junction-to-Ambient (θ <sub>JA</sub> )	24.77°C/W
Junction-to-Case Thermal Resistance (θ <sub>JC</sub> )	1.67°C/W

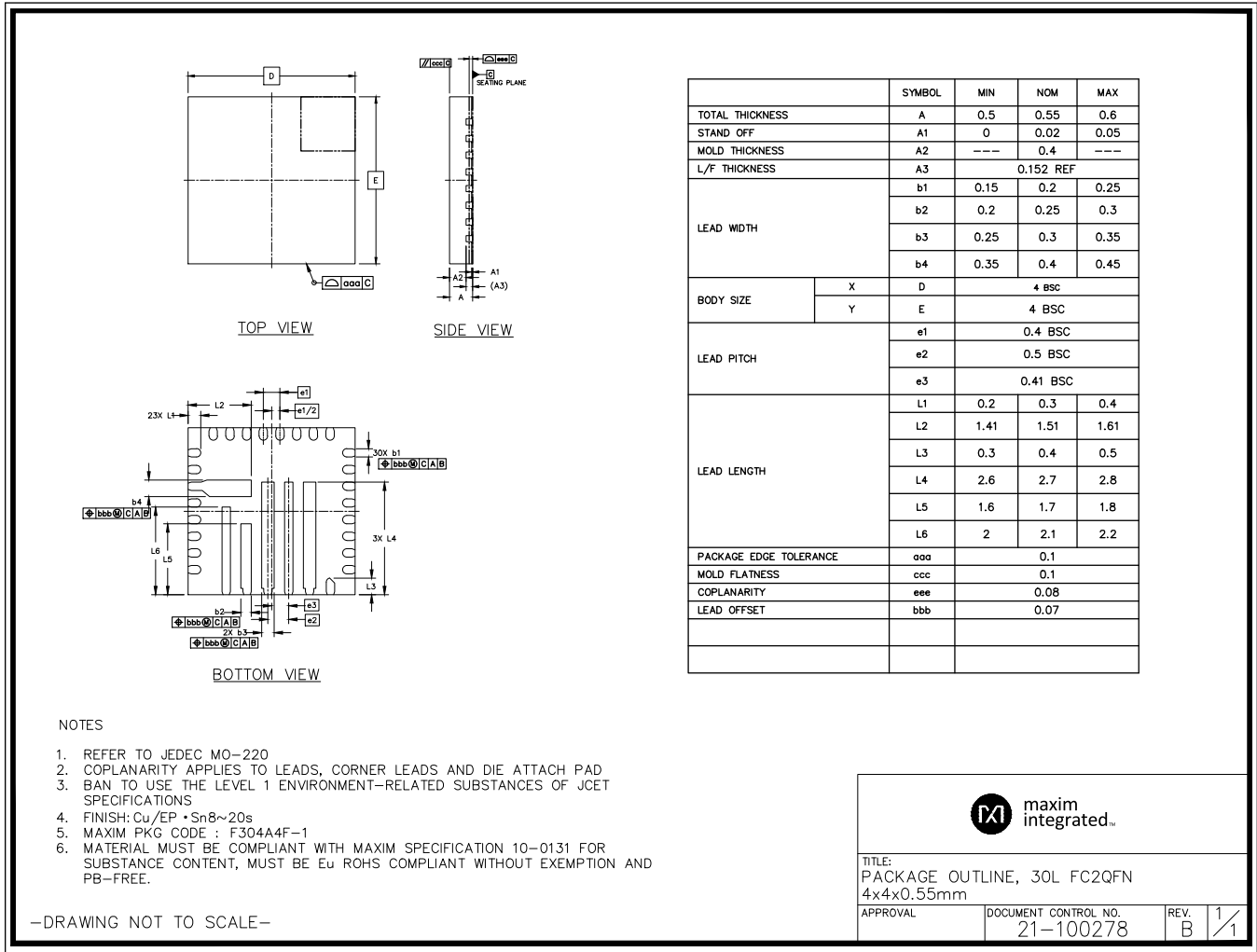

For the latest package outline information and land patterns (footprints), go to [www.maximintegrated.com/packages](http://www.maximintegrated.com/packages). Note that a “+”, “#”, or “-” in the package code indicates RoHS status only. Package drawings may show a different suffix character, but the drawing pertains to the package regardless of RoHS status.

Package thermal resistances were obtained using the method described in JEDEC specification JESD51-7, using a four-layer board. For detailed information on package thermal considerations, refer to [www.maximintegrated.com/thermal-tutorial](http://www.maximintegrated.com/thermal-tutorial).

### Electrical Characteristics

(V<sub>SYS</sub> = 7.6V, V<sub>BATT</sub> = 7.6V, V<sub>CHGIN</sub> = 9V, T<sub>A</sub> = -40°C to +85°C. T<sub>A</sub> = +25°C (typ). Limits are production tested at T<sub>A</sub> = +25°C. Limits over the operating temperature range and relevant supply voltage range are guaranteed by design and characterization.)

PARAMETER	SYMBOL	CONDITIONS	MIN	TYP	MAX	UNITS
<b>GENERAL ELECTRICAL CHARACTERISTICS</b>						
CHGIN Voltage Range	V <sub>CHGIN</sub>	Operating voltage	3.5		25.4	V
CHGIN Overvoltage Threshold	V <sub>CHGIN_OVLO</sub>	V <sub>CHGIN</sub> rising, 365mV hysteresis	25.4	26.05	26.7	V

**Electrical Characteristics (continued)**

(V<sub>SYS</sub> = 7.6V, V<sub>BATT</sub> = 7.6V, V<sub>CHGIN</sub> = 9V, T<sub>A</sub> = -40°C to +85°C. T<sub>A</sub> = +25°C (typ). Limits are production tested at T<sub>A</sub> = +25°C. Limits over the operating temperature range and relevant supply voltage range are guaranteed by design and characterization.)

PARAMETER	SYMBOL	CONDITIONS	MIN	TYP	MAX	UNITS
CHGIN Overvoltage Delay	t <sub>D_CHGIN_OVL</sub> O	V <sub>CHGIN</sub> rising, 100mV overdrive		10		μs
		V <sub>CHGIN</sub> falling, 100mV overdrive		7		ms
CHGIN Undervoltage Threshold	V <sub>CHGIN_UVLO</sub>	V <sub>CHGIN</sub> rising, 20% hysteresis	3.43	3.5	3.57	V
CHGIN Quiescent Current (I <sub>SYS</sub> = 0A)	I <sub>CHGIN</sub>	V <sub>CHGIN</sub> = 2.4V, the input is undervoltage and R <sub>INSD</sub> is the only loading		0.075		mA
		V <sub>CHGIN</sub> = 9.0V, charger disabled		0.17	0.5	
	V <sub>CHGIN</sub> = 9.0V, charger enabled, V <sub>SYS</sub> = V <sub>BATT</sub> = 8.7V (2S configuration), no switching			2.7	4	
	I <sub>CHGIN_STBY</sub>	MODE[3:0] = 0x0 (DC-DC off), STBY = H or STBY_EN = 1, V <sub>CHGIN</sub> = 5V			1	
BATT Quiescent Current (I <sub>SYS</sub> = 0A)	I <sub>SHDN</sub>	FSHIP_MODE = 1 or DISQBAT = high, V <sub>CHGIN</sub> = 0V, I <sub>SYS</sub> = 0A, V <sub>BATT</sub> = 13.5V		2.3	5.0	μA
	I <sub>BATT</sub>	DISQBAT = low, I <sup>2</sup> C enabled, V <sub>CHGIN</sub> = 0V, I <sub>SYS</sub> = 0A, V <sub>BATT</sub> = 13.5V		100	200	
		V <sub>SYS</sub> = 7.6V, V <sub>BATT</sub> = 0V, charger disabled, T <sub>A</sub> = +25°C		0.01	10	
		V <sub>SYS</sub> = 7.6V, V <sub>BATT</sub> = 0V, charger disabled, T <sub>A</sub> = +85°C		10		
	I <sub>BATTDN</sub>	V <sub>CHGIN</sub> = 9V, V <sub>BATT</sub> = 8.4V, Q <sub>BAT</sub> is off, battery overcurrent protection disabled, charger is enabled but in its done mode, T <sub>A</sub> = +25°C		57	65	
V <sub>CHGIN</sub> = 9V, V <sub>BATT</sub> = 8.4V, Q <sub>BAT</sub> is off, battery overcurrent protection disabled, charger is enabled but in its done mode, T <sub>A</sub> = +85°C			57			
SYS Operating Voltage	V <sub>SYS</sub>	Guaranteed by V <sub>SYSUVLO</sub> and V <sub>SYSOVLO</sub>	SYSUVO rising		SYSOVLO rising	V
SYS Undervoltage Lockout Threshold	V <sub>SYSUVLO</sub>	V <sub>SYS</sub> falling, 530mV hysteresis	3.95	4.1	4.25	V
SYS Overvoltage Lockout Threshold	V <sub>SYSOVLO</sub>	V <sub>SYS</sub> rising, 430mV hysteresis, 2S battery	10.65	10.9	11.15	V
		V <sub>SYS</sub> rising, 267mV hysteresis, 3S battery	13.75	14.1	14.45	
PVL Output Voltage	V <sub>PVL</sub>		1.7	1.8	1.9	V
Thermal Shutdown Threshold	T <sub>SHDN</sub>	T <sub>J</sub> rising		165		°C
Thermal Shutdown Hysteresis				15		°C
CHGIN Self-Discharge Resistance	R <sub>INSD</sub>	V <sub>CHGIN</sub> = 3V		44		kΩ
BATT Self-Discharge Resistance	R <sub>BATSD</sub>	V <sub>CHGIN</sub> = 9V, V <sub>SYS</sub> = V <sub>BATT</sub> = 5V		600		Ω

**Electrical Characteristics (continued)**

(V<sub>SYS</sub> = 7.6V, V<sub>BATT</sub> = 7.6V, V<sub>CHGIN</sub> = 9V, T<sub>A</sub> = -40°C to +85°C. T<sub>A</sub> = +25°C (typ). Limits are production tested at T<sub>A</sub> = +25°C. Limits over the operating temperature range and relevant supply voltage range are guaranteed by design and characterization.)

PARAMETER	SYMBOL	CONDITIONS	MIN	TYP	MAX	UNITS
SYS Self-Discharge Resistance	R <sub>SYSSD</sub>	V <sub>CHGIN</sub> = 9V, V <sub>SYS</sub> = V <sub>BATT</sub> = 5V		600		Ω
Self-Discharge Latch Time				300		ms
<b>SWITCH MODE CHARGER / CHARGER</b>						
BATT Regulation Voltage Range	V <sub>BATTREG</sub>	Programmable from 8.0V to 9.26V (2S battery) and 12.0V to 13.05V (3S battery), production tested at 8V, 8.38V, 8.8V and 9.26V only (2S battery) and 12V, 12.57V, 13.2V, and 13.89V only (3S battery)	8.00		13.05	V
BATT Regulation Voltage Accuracy		8.8V or 13.2V settings, T <sub>A</sub> = +25°C	-0.9	-0.3	+0.3	%
		8.8V or 13.2V settings, T <sub>A</sub> = 0°C to +85°C (Note 1)	-1	-0.3	+0.5	
BATT Overvoltage Lockout Threshold	V <sub>BATTOVLO</sub>	V <sub>BATT</sub> rising above V <sub>BATTREG</sub> , 2% hysteresis	75	240	375	mV/cell
BATT Undervoltage Lockout Threshold	V <sub>BATTUVLO</sub>	V <sub>BATT</sub> rising, 100mV hysteresis	2.0	2.5	3.0	V
Fast-Charge Current Program Range	I <sub>FC</sub>	MAX77960; 100mA to 3A; production tested at 100mA, 200mA, 500mA, 1000mA, 1500mA, 2000mA, and 3000mA settings	0.10		3	A
		MAX77961; 100mA to 6A; production tested at 100mA, 200mA, 500mA, 1000mA, 1500mA, 2000mA, 3000mA, 3500mA, and 3800mA settings	0.10		6	
Fast-Charge Current Accuracy		T <sub>A</sub> = +25°C, V <sub>BATT</sub> > V <sub>SYSTEMIN</sub> , programmed for 100mA	80	100	120	mA
		T <sub>A</sub> = +25°C, V <sub>BATT</sub> > V <sub>SYSTEMIN</sub> , programmed for 200mA	180	200	220	
		T <sub>A</sub> = +25°C, V <sub>BATT</sub> > V <sub>SYSTEMIN</sub> , programmed for 500mA	481	500	519	
		T <sub>A</sub> = +25°C, V <sub>BATT</sub> > V <sub>SYSTEMIN</sub> , programmed for 1000mA	962	1000	1038	
		T <sub>A</sub> = +25°C, V <sub>BATT</sub> > V <sub>SYSTEMIN</sub> , programmed for 2000mA	1925	2000	2075	
		T <sub>A</sub> = +25°C, V <sub>BATT</sub> > V <sub>SYSTEMIN</sub> , programmed for 3000mA	2887	3000	3113	
		MAX77961. T <sub>A</sub> = +25°C, V <sub>BATT</sub> > V <sub>SYSTEMIN</sub> , programmed for 3500mA	3369	3500	3631	
		MAX77961. T <sub>A</sub> = +25°C, V <sub>BATT</sub> > V <sub>SYSTEMIN</sub> , programmed for 3800mA	3657	3800	3943	

**Electrical Characteristics (continued)**

(V<sub>SYS</sub> = 7.6V, V<sub>BATT</sub> = 7.6V, V<sub>CHGIN</sub> = 9V, T<sub>A</sub> = -40°C to +85°C. T<sub>A</sub> = +25°C (typ). Limits are production tested at T<sub>A</sub> = +25°C. Limits over the operating temperature range and relevant supply voltage range are guaranteed by design and characterization.)

PARAMETER	SYMBOL	CONDITIONS	MIN	TYP	MAX	UNITS
Fast-Charge Current Accuracy (Over Temperature)		-40°C < T <sub>A</sub> < +85°C, V <sub>BATT</sub> > V <sub>SYSTEMIN</sub> , programmed for 200mA or less (Note 1)	-20		+20	mA
		-40°C < T <sub>A</sub> < +85°C, V <sub>BATT</sub> > V <sub>SYSTEMIN</sub> , programmed for greater than 200mA (Note 1)	-5		+5	%
CHGIN Adaptive Voltage Regulation Range	V <sub>CHGIN_REG</sub>	I <sup>2</sup> C programmable	4.025		19.05	V
CHGIN Adaptive Voltage Regulation Accuracy		4.55V setting	4.42	4.55	4.68	V
CHGIN Current Limit Range	CHGIN_ILIM	MAX77960; programmable; production tested at 100mA, 150mA, 200mA, 500mA, 1000mA, 1500mA, and 3000mA settings only	0.1		3.15	A
		MAX77961; programmable; production tested at 100mA, 150mA, 200mA, 500mA, 1000mA, 1500mA, 3000mA, 4000mA, and 6300mA settings only	0.1		6.3	
CHGIN Current Limit Accuracy		Charger enabled, 100mA input current setting, T <sub>A</sub> = +25°C	88	98	108	mA
		Charger enabled, 200mA input current setting, T <sub>A</sub> = +25°C	175	195	215	
		Charger enabled, 500mA input current setting, T <sub>A</sub> = +25°C	475	488	500	
		Charger enabled, 1000mA input current setting, T <sub>A</sub> = +25°C	950	975	1000	
		Charger enabled, 3000mA input current setting, T <sub>A</sub> = +25°C	2850	2925	3000	
		MAX77961; charger enabled, 4000mA input current setting, T <sub>A</sub> = +25°C	3800	3900	4000	
		MAX77961; charger enabled, 6300mA input current setting, T <sub>A</sub> = +25°C	5985	6143	6300	
CHGIN Current Limit Accuracy (Over Temperature)		Charger enabled, 200mA or less input current setting, -40°C < T <sub>A</sub> < +85°C (Note 1)	-22.5		+17.5	%
		Charger enabled, greater than 200mA input current setting, -40°C < T <sub>A</sub> < +85°C (Note 1)	-7.5		+2.5	
Precharge Voltage Threshold	V <sub>PRECHG</sub>	V <sub>BATT</sub> rising, voltage threshold per cell	2.4	2.5	2.6	V/Cell
Precharge Current	I <sub>PRECHG</sub>		35	50	65	mA
Prequalification Threshold Hysteresis	V <sub>PQ-H</sub>	Applies to V <sub>PRECHG</sub>		150		mV/Cell

**Electrical Characteristics (continued)**

(V<sub>SYS</sub> = 7.6V, V<sub>BATT</sub> = 7.6V, V<sub>CHGIN</sub> = 9V, T<sub>A</sub> = -40°C to +85°C. T<sub>A</sub> = +25°C (typ). Limits are production tested at T<sub>A</sub> = +25°C. Limits over the operating temperature range and relevant supply voltage range are guaranteed by design and characterization.)

PARAMETER	SYMBOL	CONDITIONS	MIN	TYP	MAX	UNITS
Minimum SYS Voltage Accuracy	V <sub>SYSTEMIN</sub>	Programmable from 5.535V to 6.970V (2S battery) and 8.303V to 10.455V (3S battery), V <sub>BATT</sub> = 5.6V (2S battery) or 8.4V (3S battery), tested at 3V/cell setting	-3		+3	%
Trickle Charge Current	I <sub>TRICKLE</sub>	Default setting = enabled; ITRICKLE[1:0] = 00	75	100	125	mA
		Default setting = enabled; ITRICKLE[1:0] = 01 (Note 1)	150	200	250	
		Default setting = enabled; ITRICKLE[1:0] = 10 (Note 1)	225	300	375	
		Default setting = enabled; ITRICKLE[1:0] = 11	300	400	500	
Top-Off Current Program Range	I <sub>TO</sub>	Programmable from 100mA to 600mA	100		600	mA
Charge Termination Deglitch Time	t <sub>TERM</sub>	2mV overdrive, 100ns rise/fall time		160		ms
Charger Restart Threshold Range	V <sub>RSTRT</sub>	Program options for disabled, 100mV/cell, 150mV/cell, and 200mV/cell with CHG_RSTRT[1:0]	100		200	mV/cell
Charger Restart Deglitch Time		10mV overdrive, 100ns rise time		130		ms
Charger State Change Interrupt Deglitch Time	t <sub>SCIDG</sub>	Excludes transition to timer fault state, watchdog timer state		30		ms
<b>SWITCH MODE CHARGER / CHARGE TIMER</b>						
Prequalification Time	t <sub>PQ</sub>	Applies to both low-battery prequalification and dead-battery prequalification modes		30		min
Fast-Charge Constant Current + Fast-Charge Constant Voltage Time	t <sub>FC</sub>	Adjustable from 3hrs, 4hrs, 5hrs, 6hrs, 7hrs, 8hrs, 10hrs including a disable setting; 3hrs default		3		hrs
Top-Off Time	t <sub>TO</sub>	Adjustable from 30s to 70min in 10min steps		30		min
<b>SWITCH MODE CHARGER / WATCHDOG TIMER</b>						
Watchdog Timer Period	t <sub>WD</sub>	(Note 2)	80			s
<b>SWITCH MODE CHARGER / BUCK-BOOST</b>						
CHGIN OK to Start Switching Delay	t <sub>START</sub>	Delay from INOKB H → L to LX_ start switching		150		ms
Buck-Boost Current Limit	HSILIM	MAX77960, V <sub>CHGIN</sub> = 9V, V <sub>SYS</sub> = V <sub>BATT</sub> = 7.6V	4.3	5	5.7	A
		MAX77961, V <sub>CHGIN</sub> = 9V, V <sub>SYS</sub> = V <sub>BATT</sub> = 7.6V	8.6	10	11.4	
<b>SWITCH MODE CHARGER / BUCK-BOOST / SWITCH IMPEDANCE AND LEAKAGE CURRENT</b>						
LX1 High-Side Resistance	R <sub>LX1_HS</sub>	V <sub>CHGIN</sub> = 9V, V <sub>SYS</sub> = V <sub>BATT</sub> = 7.6V		16.5	26	mΩ

**Electrical Characteristics (continued)**

(V<sub>SYS</sub> = 7.6V, V<sub>BATT</sub> = 7.6V, V<sub>CHGIN</sub> = 9V, T<sub>A</sub> = -40°C to +85°C. T<sub>A</sub> = +25°C (typ). Limits are production tested at T<sub>A</sub> = +25°C. Limits over the operating temperature range and relevant supply voltage range are guaranteed by design and characterization.)

PARAMETER	SYMBOL	CONDITIONS	MIN	TYP	MAX	UNITS
LX1 Low-Side Resistance	R <sub>LX1_LS</sub>	V <sub>CHGIN</sub> = 9V, V <sub>SYS</sub> = V <sub>BATT</sub> = 7.6V		17	30	mΩ
LX2 High-Side Resistance	R <sub>LX2_HS</sub>	V <sub>CHGIN</sub> = 9V, V <sub>SYS</sub> = V <sub>BATT</sub> = 7.6V		9	18	mΩ
LX2 Low-Side Resistance	R <sub>LX2_LS</sub>	V <sub>CHGIN</sub> = 9V, V <sub>SYS</sub> = V <sub>BATT</sub> = 7.6V		21	33	mΩ
LX_ Leakage Current		LX1 = PGND or CHGIN, LX2 = PGND or SYS, T <sub>A</sub> = +25°C		0.01	10	μA
		LX1 = PGND or CHGIN, LX2 = PGND or SYS, T <sub>A</sub> = +85°C		1		
BST_ Leakage Current		BST_ = 1.8V, T <sub>A</sub> = +25°C		0.01	10	μA
		BST_ = 1.8V, T <sub>A</sub> = +85°C		1		
SYS, SYSA Leakage Current		V <sub>SYS</sub> = V <sub>SYSA</sub> = 8.4V, V <sub>BATT</sub> = 0V, charger disabled, T <sub>A</sub> = +25°C		0.01	10	μA
		V <sub>SYS</sub> = V <sub>SYSA</sub> = 8.4V, V <sub>BATT</sub> = 0V, charger disabled, T <sub>A</sub> = +85°C		1		
CSINP, CSINN Leakage Current	I <sub>CSINP</sub> , I <sub>CSINN</sub>	V <sub>CHGIN</sub> = 26.05V, V <sub>CSINP</sub> = V <sub>CSINN</sub> = 26.05V, T <sub>A</sub> = +25°C	-1		+1	μA
<b>SWITCH MODE CHARGER / SMART POWER SELECTOR</b>						
BAT to SYS Dropout Resistance	R <sub>BAT2SYS</sub>			10	17	mΩ
BATT to SYS Reverse Regulation Voltage	V <sub>BSREG</sub>			90		mV
<b>SWITCH MODE CHARGER / BATT TO SYS OVERCURRENT ALERT</b>						
Battery Overcurrent Threshold Range	I <sub>BOVCR</sub>	Programmable from 3A to 10A. Option to disable.	3		10	A
Battery Overcurrent Debounce Time	t <sub>BOVRC</sub>	Response time for generating the overcurrent interrupt (Note 2)			3.3	ms
<b>SWITCH MODE CHARGER / THERMAL FOLDBACK</b>						
Junction Temperature Thermal Regulation Loop Setpoint Program Range	T <sub>REG</sub>	Junction temperature when charge current is reduced; programmable from 85°C to 130°C in 5°C steps; default value is 115°C	85		130	°C

**Electrical Characteristics (continued)**

(V<sub>SYS</sub> = 7.6V, V<sub>BATT</sub> = 7.6V, V<sub>CHGIN</sub> = 9V, T<sub>A</sub> = -40°C to +85°C. T<sub>A</sub> = +25°C (typ). Limits are production tested at T<sub>A</sub> = +25°C. Limits over the operating temperature range and relevant supply voltage range are guaranteed by design and characterization.)

PARAMETER	SYMBOL	CONDITIONS	MIN	TYP	MAX	UNITS
Thermal Regulation Gain	ATJREG	The charge current is decreased 5% of the fast-charge current setting for every degree that the junction temperature exceeds the thermal regulation temperature. This slope ensures that the full-scale current of 3A (MAX77960)/6A (MAX77961) is reduced to 0A by the time the junction temperature is 20°C above the programmed loop set point. For lower programmed charge currents such as 480mA, this slope is valid for charge current reductions down to 80mA; below 100mA the slope becomes shallower but the charge current still reduced to 0A if the junction temperature is 20°C above the programmed loop set point.		-5		%/°C
<b>SWITCH MODE CHARGER / THERMISTOR MONITOR</b>						
THM Threshold, COLD	THM_COLD	V <sub>THM</sub> /V <sub>AVL</sub> rising, 1% hysteresis (thermistor temperature falling)	70.05	74.56	77.43	%
THM Threshold, COOL	THM_COOL	V <sub>THM</sub> /V <sub>AVL</sub> rising, 1% hysteresis (thermistor temperature falling)	56.37	60	62.31	%
THM Threshold, WARM	THM_WARM	V <sub>THM</sub> /V <sub>AVL</sub> falling, 1% hysteresis (thermistor temperature rising)	32.58	34.68	36.01	%
THM Threshold, HOT	THM_HOT	V <sub>THM</sub> /V <sub>AVL</sub> falling, 1% hysteresis (thermistor temperature rising)	21.18	22.5	23.41	%
THM Threshold, Disabled		V <sub>THM</sub> /V <sub>AVL</sub> falling, 1% hysteresis, THM function is disabled below this voltage	4.67	5.9	7.01	%
THM Threshold, Battery Removal Detection		V <sub>THM</sub> /V <sub>AVL</sub> rising, 1% hysteresis, battery removal	81.74	87	90.35	%
THM Input Leakage Current		V <sub>THM</sub> = GND or V <sub>AVL</sub> ; T <sub>A</sub> = +25°C		0.1	1	μA
		V <sub>THM</sub> = GND or V <sub>AVL</sub> ; T <sub>A</sub> = +85°C		0.1		
<b>REVERSE BUCK</b>						
Buck Current Limit	HSILIM_REV	f <sub>SW</sub> = 600kHz	4.3	5	5.7	A
Reverse Buck Quiescent Current		Not switching: output forced 200mV above its target regulation voltage		1150		μA
Minimum BATT Voltage in OTG Mode	V <sub>BATT.MIN.OTG</sub>	V <sub>BATT</sub> = V <sub>SYS</sub> , SYS UVLO falling threshold in OTG mode	5.96	6.14	6.32	V
CHGIN Voltage in OTG Mode	V <sub>CHGIN.OTG</sub>	V <sub>BATT</sub> = V <sub>BATT.MIN.OTG</sub> , OTGEN = high	4.94	5.1	5.26	V
CHGIN Undervoltage Threshold in OTG Mode	V <sub>CHGIN.OTG.UV</sub>	V <sub>CHGIN</sub> falling, OTGEN = high		85		%
CHGIN Overvoltage Threshold in OTG Mode	V <sub>CHGIN.OTG.OV</sub>	V <sub>CHGIN</sub> rising, OTGEN = high		110		%

**Electrical Characteristics (continued)**

(V<sub>SYS</sub> = 7.6V, V<sub>BATT</sub> = 7.6V, V<sub>CHGIN</sub> = 9V, T<sub>A</sub> = -40°C to +85°C. T<sub>A</sub> = +25°C (typ). Limits are production tested at T<sub>A</sub> = +25°C. Limits over the operating temperature range and relevant supply voltage range are guaranteed by design and characterization.)

PARAMETER	SYMBOL	CONDITIONS	MIN	TYP	MAX	UNITS
CHGIN Output Current Limit in OTG Mode	I <sub>CHGIN.OTG.LIM</sub>	V <sub>BATT</sub> = V <sub>BATT.MIN.OTG</sub> , T <sub>A</sub> = +25°C, OTG_ILIM[2:0] = 0b000, OTGEN = high		500	550	mA
		V <sub>BATT</sub> = V <sub>BATT.MIN.OTG</sub> , T <sub>A</sub> = +25°C, OTG_ILIM[2:0] = 0b001, OTGEN = high		900	990	
		V <sub>BATT</sub> = V <sub>BATT.MIN.OTG</sub> , T <sub>A</sub> = +25°C, OTG_ILIM[2:0] = 0b011, OTGEN = high		1500	1650	
		V <sub>BATT</sub> = V <sub>BATT.MIN.OTG</sub> , T <sub>A</sub> = +25°C, OTG_ILIM[2:0] = 0b111, OTGEN = high		3000	3300	
CHGIN Output Voltage Ripple in OTG Mode		Discontinuous inductor current (i.e., skip mode), OTGEN = high		±150		mV
		Continuous inductor current, OTGEN = high		±150		
<b>IO CHARACTERISTICS</b>						
R <sub>INLIM</sub> , R <sub>ISET</sub> , R <sub>VSET</sub> , R <sub>T0</sub> , R <sub>CNFG</sub> Resistor Range	R <sub>PROG_</sub>		5.49		226	kΩ
Output Low Voltage INOKB, STAT		I <sub>SINK</sub> = 1mA, T <sub>A</sub> = +25°C			0.4	V
Output High Leakage INOKB, STAT		5.5V, T <sub>A</sub> = +25°C	-1	0	+1	μA
		5.5V, T <sub>A</sub> = +85°C		0.1		
DISQBAT, OTGEN, STBY Logic Input Low Threshold	V <sub>IL</sub>				0.4	V
DISQBAT, OTGEN, STBY Logic Input High Threshold	V <sub>IH</sub>		1.4			V
DISQBAT, OTGEN, STBY Logic Input Leakage Current		5.5V (including current through pulldown resistor)		5.5	10	μA
DISQBAT, OTGEN, STBY Pulldown Resistor	R <sub>DISQBAT</sub>			1000	1200	kΩ
<b>INTERFACE / I<sup>2</sup>C INTERFACE AND INTERRUPT</b>						
SCL, SDA Input Low Level					0.3 x V <sub>AVL</sub>	V
SCL, SDA Input High Level			0.7 x V <sub>AVL</sub>			V
SCL, SDA Input Hysteresis				0.05 x V <sub>AVL</sub>		V
SCL, SDA Logic Input Current		SDA = SCL = 5.5V	-10		+10	μA
SCL, SDA Input Capacitance				10		pF
SDA Output Low Voltage		Sinking 20mA			0.4	V

**Electrical Characteristics (continued)**

(V<sub>SYS</sub> = 7.6V, V<sub>BATT</sub> = 7.6V, V<sub>CHGIN</sub> = 9V, T<sub>A</sub> = -40°C to +85°C. T<sub>A</sub> = +25°C (typ). Limits are production tested at T<sub>A</sub> = +25°C. Limits over the operating temperature range and relevant supply voltage range are guaranteed by design and characterization.)

PARAMETER	SYMBOL	CONDITIONS	MIN	TYP	MAX	UNITS
Output Low Voltage INTB		I <sub>SINK</sub> = 1mA			0.4	V
Output High Leakage INTB		V <sub>INTB</sub> = 5.5V, T <sub>A</sub> = +25°C	-1	0	+1	μA
		V <sub>INTB</sub> = 5.5V, T <sub>A</sub> = +85°C		0.1		
<b>INTERFACE / I<sup>2</sup>C COMPATIBLE INTERFACE TIMING FOR STANDARD, FAST, AND FAST-MODE PLUS</b>						
Clock Frequency	f <sub>SCL</sub>				1000	kHz
Hold Time (Repeated) START Condition	t <sub>HD;STA</sub>		0.26			μs
CLK Low Period	t <sub>LOW</sub>		0.5			μs
CLK High Period	t <sub>HIGH</sub>		0.26			μs
Set-Up Time Repeated START Condition	t <sub>SU;STA</sub>		0.26			μs
DATA Hold Time	t <sub>HD;DAT</sub>		0			μs
DATA Valid Time	t <sub>VD;DAT</sub>				0.45	μs
DATA Valid Acknowledge Time	t <sub>VD;ACK</sub>				0.45	μs
DATA Set-Up time	t <sub>SU;DAT</sub>		50			ns
Set-Up Time for STOP Condition	t <sub>SU;STO</sub>		0.26			μs
Bus-Free Time Between STOP and START	t <sub>BUF</sub>		0.5			μs
Pulse Width of Spikes that Must be Suppressed by the Input Filter				50		ns
<b>INTERFACE / I<sup>2</sup>C COMPATIBLE INTERFACE TIMING FOR HS-MODE (C<sub>B</sub> = 100pF)</b>						
Clock Frequency	f <sub>SCL</sub>				3.4	MHz
Set-Up Time Repeated START Condition	t <sub>SU;STA</sub>		160			ns
Hold Time (Repeated) START Condition	t <sub>HD;STA</sub>		160			ns
CLK Low Period	t <sub>LOW</sub>		160			ns
CLK High Period	t <sub>HIGH</sub>		60			ns
DATA Set-Up Time	t <sub>SU;DAT</sub>		10			ns
DATA Hold Time	t <sub>HD;DAT</sub>		0			ns
Set-Up Time for STOP Condition	t <sub>SU;STO</sub>		160			ns
Pulse Width of Spikes that Must be Suppressed by the Input Filter				10		ns
<b>INTERFACE / I<sup>2</sup>C COMPATIBLE INTERFACE TIMING FOR HS-MODE (C<sub>B</sub> = 400pF)</b>						
Clock Frequency	f <sub>SCL</sub>				1.7	MHz

**Electrical Characteristics (continued)**

(V<sub>SYS</sub> = 7.6V, V<sub>BATT</sub> = 7.6V, V<sub>CHGIN</sub> = 9V, T<sub>A</sub> = -40°C to +85°C. T<sub>A</sub> = +25°C (typ). Limits are production tested at T<sub>A</sub> = +25°C. Limits over the operating temperature range and relevant supply voltage range are guaranteed by design and characterization.)

PARAMETER	SYMBOL	CONDITIONS	MIN	TYP	MAX	UNITS
Set-Up Time Repeated START Condition	t <sub>SU;STA</sub>		160			ns
Hold Time (Repeated) START Condition	t <sub>HD;STA</sub>		160			ns
CLK Low Period	t <sub>LOW</sub>		320			ns
CLK High Period	t <sub>HIGH</sub>		120			ns
DATA Set-Up time	t <sub>SU;DAT</sub>		10			ns
DATA Hold Time	t <sub>HD;DAT</sub>		0			ns
Set-Up Time for STOP Condition	t <sub>SU;STO</sub>		160			ns
Pulse Width of Spikes that Must be Suppressed by the Input Filter				10		ns

**Note 1:** Guaranteed by design. Not production tested.

**Note 2:** Guaranteed by design. Production tested through scan.

**Typical Operating Characteristics**

(C<sub>CHGIN</sub> = 10μF, C<sub>SYS</sub> = 2 x 47μF, L = 3.3μH (CMLE063T-3R3MS), T<sub>A</sub> = +25°C unless otherwise noted.)

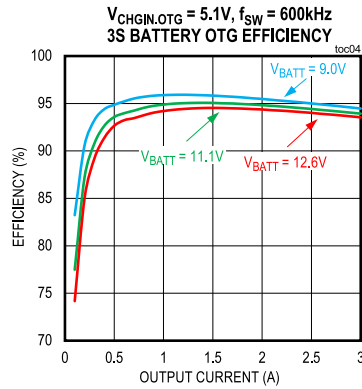
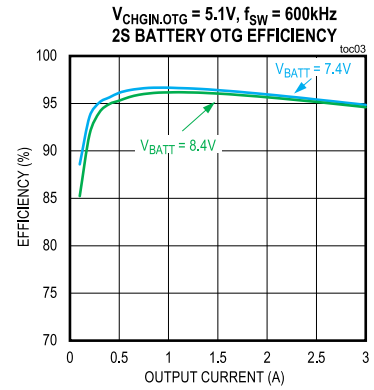
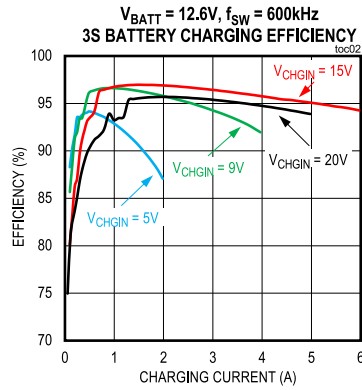
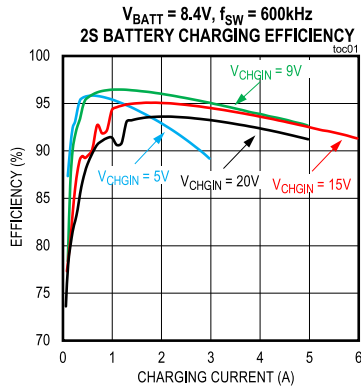

Pin Configuration

MAX77960/MAX77961

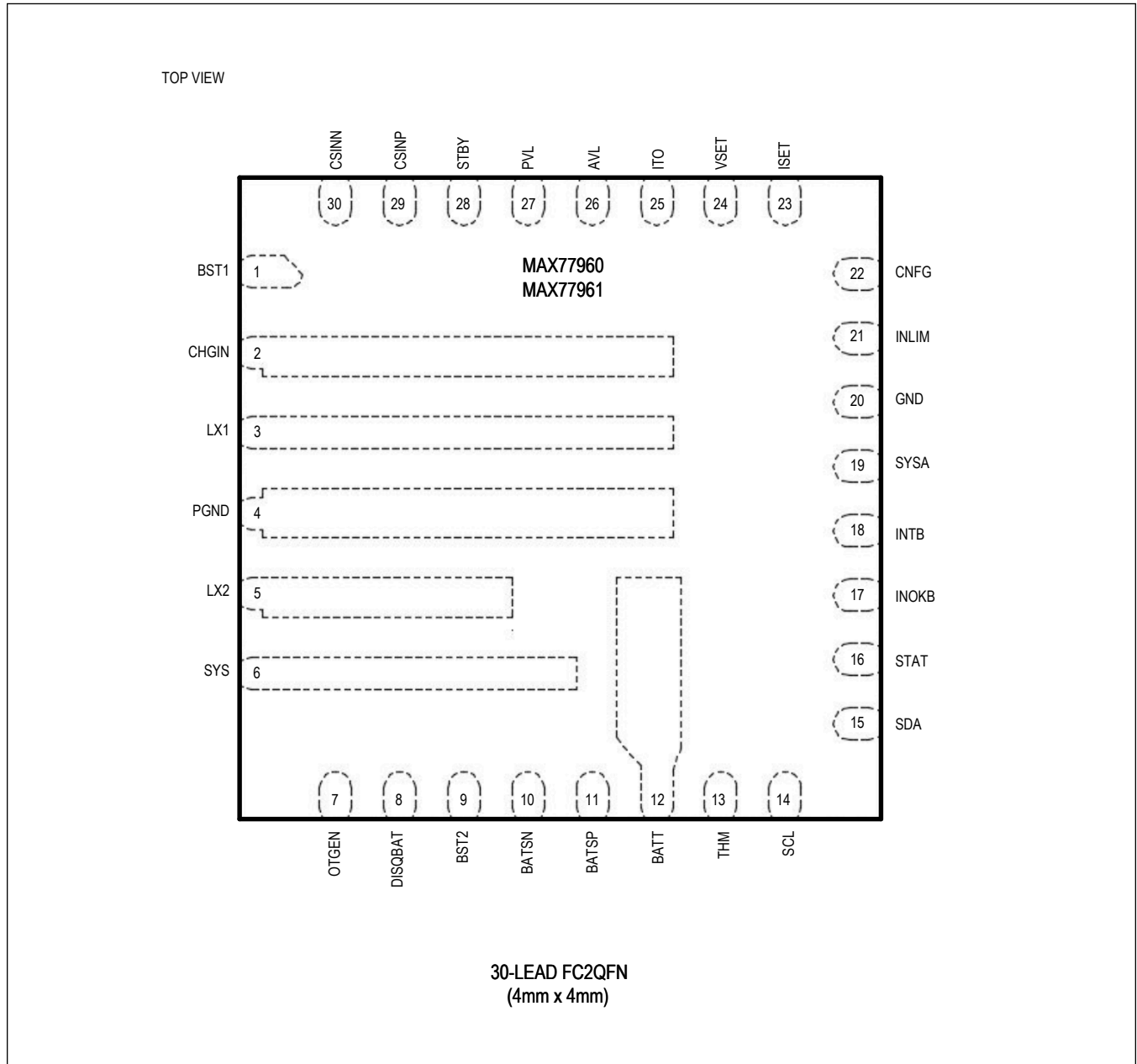

## Pin Description

PIN	NAME	FUNCTION
1	BST1	High-Side Input MOSFET Driver Supply. Bypass BST1 to LX1 with a 0.22μF/6.3V capacitor.
2	CHGIN	Buck-Boost Charger Input. CHGIN is also the buck output when the charger is operating in the reverse mode. Bypass with two 10μF/35V ceramic capacitors from CHGIN to PGND.
3	LX1	Inductor Connection One. Connect an inductor between LX1 and LX2.
4	PGND	Power Ground for Buck-Boost Low-Side MOSFETs
5	LX2	Inductor Connection Two. Connect an inductor between LX1 and LX2.
6	SYS	System Supply Output. Bypass SYS to PGND with a minimum of two 47μF/25V ceramic capacitors.
7	OTGEN	Active-High Input. Connect the OTGEN pin to high enables the OTG function. When OTGEN pin is pulled low, the OTG enable function is controlled by I <sup>2</sup> C. To pull the OTGEN pin low with a pulldown resistor, the resistance must be lower than 44kΩ.
8	DISQBAT	Active-High Input. Connect high to disable the integrated Q <sub>BAT</sub> FET between SYS and BATT. Charging is disabled when DISQBAT connects to high. When DISQBAT is pulled low, Q <sub>BAT</sub> FET control is defined in the <a href="#">Q<sub>BAT</sub> and DC-DC Control—Configuration Table</a> . To pull the DISQBAT pin low with a pulldown resistor, the resistance must be lower than 44kΩ.
9	BST2	High-Side Output MOSFET Driver Supply. Bypass BST2 to LX2 with a 0.22μF/6.3V capacitor.
10	BATSN	Battery Voltage Differential Sense Negative Input. Connect to the negative terminal of the battery pack.
11	BATSP	Battery Voltage Differential Sense Positive Input. Connect to the positive terminal of the battery pack.
12	BATT	Battery Power Connection. Connect to the positive terminal of the battery pack. Bypass BATT to PGND with a 10μF/25V capacitor. All BATT pins must be connected together externally.
13	THM	Thermistor Input. Connect a negative temperature coefficient (NTC) thermistor from THM to GND. Connect a resistor equal to the thermistor +25°C resistance from THM to AVL. JEITA-controlled charging available with JEITA_EN = 1. Charging is suspended when the thermistor voltage is outside of the hot and cold limits. Connect THM to GND to disable the thermistor temperature sensor. Connect THM to AVL to emulate battery removal and prevent charging.
14	SCL	Serial Interface I <sup>2</sup> C Clock Input
15	SDA	Serial Interface I <sup>2</sup> C Data. Open-drain output.
16	STAT	Charger Status Output. Active-low, open-drain output, connect to the pullup through a 10kΩ resistor. Pulls low when the charging is in progress. Otherwise, STAT is high impedance.  STAT toggles between low and high (when connected to a pullup rail) during charge. STAT becomes low when top-off threshold is detected and charger enters the done state. STAT becomes high (when connected to a pullup rail) when charge faults are detected.
17	INOKB	Input Power-OK/OTG Power-OK Output. Active-low, open-drain output pulls low when the CHGIN voltage is valid.
18	INTB	Active-Low Open-Drain Interrupt Output. Connect a pullup resistor to the pullup power source.
19	SYSA	SYS Voltage Sensing Input for SYS UVLO and OVLO Detection
20	GND	Analog Ground
21	INLIM	Charger Input Current Limit Setting Input. Connect a resistor (R <sub>INLIM</sub> ) from INLIM to GND programs the charger input current limit. Refer to <a href="#">Table 5</a> .
22	CNFG	Device Configuration Input. Connect a resistor (R <sub>CNFG</sub> ) from CNFG to GND to program the following parameter, see <a href="#">Table 1</a> . <ul style="list-style-type: none"> <li>Number of battery cells in series connection (2S or 3S)</li> </ul>
23	ISET	Fast-Charge Current Setting Input. Connect a resistor (R <sub>ISET</sub> ) from ISET to GND programs the fast charge current. See <a href="#">Table 6</a> .

**Pin Description (continued)**

PIN	NAME	FUNCTION
24	VSET	Charge Termination Voltage Setting Input. Connect a resistor (R <sub>VSET</sub> ) from VSET to GND programs the charge termination voltage. See <a href="#">Table 8</a> .
25	ITO	Top-Off Current Setting Input. Connect a resistor (R <sub>ITO</sub> ) from ITO to GND programs the top-off current. See <a href="#">Table 7</a> .
26	AVL	Analog Voltage Supply for On-Chip, Low-Noise Circuits. Bypass with a 4.7μF/6.3V ceramic capacitor to GND and connect AVL to PVL with a 4.7Ω resistor.
27	PVL	Internal Bias Regulator High Current Output Bypass. Supports internal noisy and high current gate drive loads. Bypass to GND with a minimum 4.7μF/6.3V ceramic capacitor, and connect AVL to PVL with a 4.7Ω resistor. Powering external loads from PVL is not recommended, other than pullup resistors.
28	STBY	Active-High Input. Connect high to disable the DC-DC between CHGIN input and SYS output. Battery supplies the system power if the Q <sub>BAT</sub> is on. See <a href="#">Table 2</a> . Connect low to control the DC-DC with the power-path state machine. To pull the STBY pin low with a pulldown resistor, the resistance must be lower than 44kΩ.
29	CSINP	Input Current-Sense Positive Input
30	CSINN	Input Current-Sense Negative Input

## Detailed Description

### Charger Configuration

The MAX77960/MAX77961 are highly flexible, highly integrated switch mode charger. Autonomous charging inputs configure the charger without host I<sup>2</sup>C interface, see the [Autonomous Charging](#) section for more details. The MAX77960/MAX77961 have an I<sup>2</sup>C interface that allows the host controller to program and monitor the charger. Charger configuration registers, interrupt, interrupt mask, and status registers are described in the [Register Map](#).

### Device Configuration Input (CNFG)

The CNFG is the MAX77960/MAX77961's configuration input for the number of battery cells in series connection (2S or 3S).

Connect a resistor (R<sub>CNFG</sub>) from CNFG to GND to program. See [Table 1](#).

**Table 1. CNFG Program Options Lookup Table**

PART NUMBER	SWITCHING FREQUENCY (MHz)	NUMBER OF SERIES BATTERY CELLS	R <sub>CNFG</sub> (Ω)
MAX77960EFV06+ MAX77961EFV06+	0.6	2	Tied to PVL or 86600
		3	8660

### CHGIN Standby Input (STBY)

The host can reduce the MAX77960/MAX77961's CHGIN supply current by driving STBY pin to high or setting STBY\_EN bit to 1. When STBY is pulled high or STBY\_EN bit is set to 1, the DC-DC turns off. When STBY is pulled low and STBY\_EN bit is set to 0, the DC-DC is controlled by the power-path state machine. To pull the STBY pin low with a pulldown resistor, the resistance must be lower than 44kΩ.

### Battery to SYS Q<sub>BAT</sub> Disable Input (DISQBAT)

The host can disable the Q<sub>BAT</sub> switch by setting DISIBS bit to 1 or driving DISQBAT pin to high. Charging stops when Q<sub>BAT</sub> switch is disabled.

When DISQBAT is pulled low and DISIBS bit is set to 0, Q<sub>BAT</sub> FET control is defined in [Table 2](#). To pull the DISQBAT pin low with a pulldown resistor, the resistance must be lower than 44kΩ.

### Q<sub>BAT</sub> and DC-DC Control—Configuration Table

The Q<sub>BAT</sub> control and the DC-DC control depend on both hardware pins (OTGEN, DISQBAT, and STBY) and their associated I<sup>2</sup>C registers.

**Table 2. Q<sub>BAT</sub> and DC-DC Control Configuration Table**

OTGEN (PIN) OR MODE [3:0] = 0xA (I <sup>2</sup> C)	DISQBAT (PIN) OR DISIBS (I <sup>2</sup> C)	STBY (PIN) OR STBY_EN (I <sup>2</sup> C)	Q <sub>BAT</sub>	DC-DC
0	0	0	Power-path state machine/internal logic control	Power-path state machine/internal logic control
0	0	1	Enable (SYS is powered from battery through Q <sub>BAT</sub> switch while DC-DC is disabled)	Disable
0	1	0	Disable	Power-path state machine/internal logic control

**Table 2. Q<sub>BAT</sub> and DC-DC Control Configuration Table (continued)**

OTGEN (PIN) OR MODE [3:0] = 0xA (I <sup>2</sup> C)	DISQBAT (PIN) OR DISIBS (I <sup>2</sup> C)	STBY (PIN) OR STBY_EN (I <sup>2</sup> C)	Q <sub>BAT</sub>	DC-DC
0	1	1	Disable (SYS is powered from battery through Q <sub>BAT</sub> body diode while DC-DC is disabled)	Disable
1	x	x	Enable	Power-path state machine/internal logic control

**Thermistor Input (THM)**

The thermistor input can be utilized to achieve functions that include charge suspension, JEITA-compliant charging, and battery removal detection. Thermistor monitoring feature can be disabled by connecting the THM pin to ground.

**Charge Suspension**

The THM input connects to an external negative temperature coefficient (NTC) thermistor to monitor battery or system temperature. Charging stops when the thermistor temperature is out of range ( $T < T_{COLD}$  or  $T > T_{HOT}$ ). The charge timers are reset and the CHG\_DTLS[3:0], CHG\_OK register bits report the charging suspension status and CHG\_I interrupt bit is set. When the thermistor comes back into range ( $T_{COLD} < T < T_{HOT}$ ), charging resumes and the charge timer restarts.

**JEITA-Compliant Charging**

JEITA-compliant charging is available with JEITA\_EN = 1. See the [JEITA Compliance](#) section for more details.

**Battery Removal Detection**

Connecting THM to AVL emulates battery removal and prevents charging.

**Disable Thermistor Monitoring**

Connecting THM to GND disables the thermistor monitoring function, and JEITA-controlled charging is unavailable in this configuration. The MAX77960/MAX77961 detect an always-connected battery when THM is grounded, and charging starts automatically when a valid adapter is plugged in. In applications with removable batteries, do not connect THM to GND because the MAX77960/MAX77961 cannot detect battery removal when THM is grounded. Instead, connecting THM to the thermistor pin in the battery pack is recommended.

Since the thermistor monitoring circuit employs an external bias resistor from THM to AVL, the thermistor is not limited only to 10kΩ (at +25°C). Any resistance thermistor can be used as long as the value is equivalent to the thermistors +25°C resistance. For example, with a 10kΩ at R<sub>TB</sub> resistor, the charger enters a temperature suspend state when the thermistor resistance falls below 3.97kΩ (too hot) or rises above 28.7kΩ (too cold). This corresponds to 0°C to +50°C range when using a 10kΩ NTC thermistor with a beta of 3500. The general relation of thermistor resistance to temperature is defined by the following equation:

$$R_T = R_{25} \times e^{\left\{ \beta \times \left( \frac{1}{T + 273^\circ\text{C}} - \frac{1}{298^\circ\text{C}} \right) \right\}}$$

where:

R<sub>T</sub> = The resistance in Ω of the thermistor at temperature T in Celsius

R<sub>25</sub> = The resistance in Ω of the thermistor at +25°C

β = The material constant of the thermistor, which typically ranges from 3000k to 5000k

T = The temperature of the thermistor in °C

Some designs might prefer other thermistor temperature limits. Threshold adjustment can be accommodated by changing R<sub>TB</sub>, connecting a resistor in series and/or in parallel with the thermistor, or using a thermistor with different β. For example, a +45°C hot threshold and 0°C cold threshold can be realized by using a thermistor with a β to 4250 and connecting 120kΩ in parallel. Since the thermistor resistance near 0°C is much higher than it is near +50°C, a large parallel resistance lowers the cold threshold, while only slightly lowering the hot threshold. Conversely, a small series resistance raises the hot threshold, while only slightly raising the cold threshold. Raising R<sub>TB</sub> raises both the hot and cold threshold, while lowering R<sub>TB</sub> lowers both thresholds.

Since AVL is active whenever a valid power is provided at CHGIN or BATT, thermistor bias current flows at all times, even when charging is disabled. When using a 10kΩ thermistor and a 10kΩ pullup to AVL, this results in an additional 90μA load. This load can be reduced to 9μA by instead using a 100kΩ thermistor and 100kΩ pullup resistor.

**Table 3. Trip Temperatures for Different Thermistors**

THERMISTOR					TRIP TEMPERATURES			
R <sub>25</sub> (Ω)	β	R <sub>TB</sub> (Ω)	R <sub>15</sub> (Ω)	R <sub>45</sub> (Ω)	T <sub>COLD</sub> (°C)	T <sub>COOL</sub> (°C)	T <sub>WARM</sub> (°C)	T <sub>HOT</sub> (°C)
10000	3380	10000	14826	4900	-0.8	+14.7	+42.6	+61.4
10000	3940	10000	15826	4354	+2.6	+16.1	+40.0	+55.7
47000	4050	47000	75342	19993	+3.2	+16.4	+39.6	+54.8
100000	4250	100000	164083	40781	+4.1	+16.8	+38.8	+53.2

### Autonomous Charging

The MAX77960/MAX77961 support autonomous charging without I<sup>2</sup>C. In applications without I<sup>2</sup>C serial communication, use the following pins to configure the MAX77960/MAX77961 charger:

CNFG, INLIM, ITO, ISET, VSET, OTGEN, DISQBAT, STBY.

The INLIM, ITO, ISET, and VSET pins are used to program the charger's input current limit, top-off current, constant charging current, and termination voltage.

Connect a valid resistor from each of these pins to ground to program the charger. See the [Pin Description](#) for details.

Connect all four pins (INLIM, ITO, ISET, VSET) to PVL to use the default values for the associated charger registers.

For autonomous charging, it is considered an abnormal condition if some of these pins (INLIM, ITO, ISET, VSET) connect to a valid resistor, but others do not (for example open or connects to PVL or connects to a resistor that is out of range). When this happens, the MAX77960/MAX77961 allow the DC-DC to switch and regulate the SYS voltage, but disable charging for safety reasons. The STAT pin reports no charge.

**Table 4. INLIM, ITO, ISET, and VSET Pin Connections for Autonomous Charging**

INLIM PIN	ITO PIN	ISET PIN	VSET PIN	AUTONOMOUS CHARGING
Valid resistor	Valid resistor	Valid resistor	Valid resistor	Normal, charger configuration is programmed by resistors
Tied to PVL	Tied to PVL	Tied to PVL	Tied to PVL	Normal, charger configuration uses default values
All other connections				Abnormal, no charging

**Charger Input Current Limit Setting Input (INLIM)**

When a valid charge source is applied to CHGIN, the MAX77960/MAX77961 limit the current drawn from the charge source to the value programmed with INLIM pin.

The default charger input current limit is programmed with the resistance from INLIM to GND. See [Table 5](#).

If I<sup>2</sup>C is used in the application, the CHGIN input current limit can also be reprogrammed with CHGIN\_ILIM[6:0] register bits after the devices power up. Connect INLIM pin to PVL to use I<sup>2</sup>C default settings.

**Table 5. INLIM Program Options Lookup Table**

R <sub>INLIM</sub> (Ω)	MAX77960 CHGIN INPUT CURRENT LIMIT (mA) DEFAULT VALUE OF CHGIN_ILIM[6:0]	MAX77961 CHGIN INPUT CURRENT LIMIT (mA) DEFAULT VALUE OF CHGIN_ILIM[6:0]
Tied to PVL	500	500
226000	100	100
178000	200	200
140000	300	300
110000	400	400
86600	500	500
69800	1000	1000
54900	1500	1500
39200	2000	2000
22600	2500	2500
17800	3000	3000
14000	N/A	3500
11000	N/A	4000
8660	N/A	4500
6980	N/A	5000
5490	N/A	6000

**Fast-Charge Current Setting Input (ISET)**

When a valid input source is present, the battery charger attempts to charge the battery with a fast-charge current programmed with ISET pin.

The default fast-charge current is programmed with the resistance from ISET to GND. See [Table 6](#).

If I<sup>2</sup>C is used in the application, the fast-charge current can also be reprogrammed with CHGCC[5:0] register bits after the devices power up. Connect ISET pin to PVL to use I<sup>2</sup>C default settings.

**Table 6. ISET Program Options Lookup Table**

R <sub>ISET</sub> (Ω)	MAX77960 FAST-CHARGE CURRENT SELECTION (mA) DEFAULT VALUE OF CHGCC[5:0]	MAX77961 FAST-CHARGE CURRENT SELECTION (mA) DEFAULT VALUE OF CHGCC[5:0]
Tied to PVL	450	450
226000	100	100

**Table 6. ISET Program Options Lookup Table (continued)**

R <sub>ISET</sub> (Ω)	MAX77960 FAST-CHARGE CURRENT SELECTION (mA) DEFAULT VALUE OF CHGCC[5:0]	MAX77961 FAST-CHARGE CURRENT SELECTION (mA) DEFAULT VALUE OF CHGCC[5:0]
178000	200	200
140000	300	300
110000	400	400
86600	500	500
69800	1000	1000
54900	1500	1500
39200	2000	2000
22600	2500	2500
17800	3000	3000
14000	N/A	3500
11000	N/A	4000
8660	N/A	4500
6980	N/A	5000
5490	N/A	6000

**Top-Off Current Setting Input (ITO)**

When the battery charger is in the top-off state, the top-off charge current is programmed by ITO pin.

The default top-off charge current is programmed with the resistance from ITO to GND. See [Table 7](#).

If I<sup>2</sup>C is used in the application, the top-off current can also be reprogrammed with TO\_ITH[2:0] register bits after the device powers up. Connect ITO pin to PVL to use I<sup>2</sup>C default settings.

**Table 7. ITO Program Options Lookup Table**

R <sub>ITO</sub> (Ω)	TOP-OFF CURRENT THRESHOLD (mA) DEFAULT VALUE OF TO_ITH[2:0]
Tied to PVL	100
226000	100
178000	200
140000	300
110000	400
86600	500
69800	600

**Charge Termination Voltage Setting Input (VSET)**

The default charge termination voltage is programmed with the resistance from VSET to GND. See [Table 8](#).

If I<sup>2</sup>C is used in the application, the charge termination voltage can also be reprogrammed with CHG\_CV\_PRM[5:0] register bits after the device powers up. Connect the VSET pin to PVL to use I<sup>2</sup>C default settings.

**Table 8. VSET Program Options Lookup Table**

R <sub>VSET</sub> (Ω)	CHARGE TERMINATION VOLTAGE SETTING - 2S (V) DEFAULT VALUE OF CHG_CV_PRM[5:0]	CHARGE TERMINATION VOLTAGE SETTING - 3S (V) DEFAULT VALUE OF CHG_CV_PRM[5:0]
Tied to PVL	8.0	12.0
226000	8.0	12.0
178000	8.1	12.15
140000	8.2	12.3
110000	8.3	12.45
86600	8.4	12.6
69800	8.5	12.75
54900	8.6	12.9
39200	8.7	13.05
22600	8.8	N/A
17800	8.9	N/A
14000	9.0	N/A
11000	9.1	N/A
8660	9.2	N/A
6980	9.26	N/A
5490	9.26	N/A

### Switch Mode Charger

The MAX77960/MAX77961 feature a switch mode buck-boost charger for a two-cell or three-cell lithium ion (Li+) or lithium polymer (Li-polymer) battery. The charger operates from a wide input range from 3.5V to 25.4V, ideal for USB-C charging applications. The charger input current limit is programmable from 100mA to 3.15A (MAX77960)/100mA to 6.3A (MAX77961), which is flexible to operate from either an AC-to-DC wall charger or a USB-C adapter.

The MAX77960/MAX77961 offer a high level of integration and do not require any external MOSFETs to operate, which significantly reduces the solution size. They operate with a fixed switching frequency of 600kHz. The battery charging current is programmable from 100mA to 3A (MAX77960)/100mA to 6A (MAX77961) to accommodate small or large capacity batteries.

When the input source is not available, the MAX77960/MAX77961 can be enabled in a reverse buck mode, delivering energy from the battery to the input, CHGIN, commonly known as USB on-the-go (OTG). In OTG mode, the regulated CHGIN voltage is 5.1V with programmable current limit up to 3A.

Maxim's Smart Power Selector architecture makes the best use of the limited adapter power and the battery power to power the system. Adapter power that is not used for the system charges the battery. When system load exceeds the input limit, battery provides additional current to the system up to the BATT to SYS overcurrent threshold, programmable with B2SOVRC[3:0] I<sup>2</sup>C register bits. All power switches for charging and switching the system load between battery and adapter power are integrated on chip—no external MOSFETs required.

Maxim's proprietary process technology allows for low-R<sub>DSON</sub> devices in a small solution size. The resistance between BATT and SYS is 10mΩ (typ), allowing low power dissipation and long battery life.

A multitude of safety features ensure reliable charging. Features include charge timers, watchdog, junction thermal regulation, and over-/undervoltage protection.

### Smart Power Selector (SPS)

The smart power selector (SPS) architecture includes a network of internal switches and control loops that efficiently distributes energy between an external power source (CHGIN), the battery (BAT) and the system (SYS). This architecture allows power path operation with system instant on with a dead battery.

The [Simplified Block Diagram](#) shows the smart power selector switches and gives them the following names: Q<sub>1</sub>, Q<sub>2</sub>, Q<sub>3</sub>, Q<sub>4</sub> and Q<sub>BAT</sub>.

### Power Switches and Current Sense Resistor Descriptions

- CHGIN Current-Sense Resistor: As shown in the [Simplified Block Diagram](#), the CHGIN current is monitored with the input current sensing resistor, R<sub>CS1</sub>, connected between CSINP and CSINN pins.
- DC-DC Switches: Q<sub>1</sub>, Q<sub>2</sub>, Q<sub>3</sub>, and Q<sub>4</sub> are the DC-DC switches that can operate as a buck (step down) or a boost (step up), depending on the external power source and battery voltage conditions.
- Battery-to-System Switch: Q<sub>BAT</sub> is used to control battery charging and discharging operations.

### I<sup>2</sup>C Configuration Register Bits

- MODE[3:0] configures the Smart Power Selector mode to be Charging, OTG or DC-DC mode respectively. See MODE[3:0] register bits in the [Register Map](#) for details.
- VCHGIN\_REG[4:0] sets the CHGIN regulation voltage, when the MAX77960/MAX77961 operate in forward mode (CHGIN has a valid power source). See the [CHGIN Regulation Voltage](#) section for details.
- MINVSYS[2:0] sets the minimum system regulation voltage. See the [SYS Regulation Voltage](#) section for details.
- B2SOVRC[3:0] sets the battery to system discharge overcurrent protection threshold.

### Energy Distribution Priority

- With a valid external power source at CHGIN:
  - The external power source is the primary source of energy.
  - The battery is the secondary source of energy.
  - Energy delivery to SYS has the highest priority.
  - Any remaining energy from the power source that is not required by the system is available to the battery charger.
- With no valid external power source at CHGIN:
  - The battery is the primary source of energy.
  - When OTG mode is enabled, energy delivery to SYS has the highest priority.
  - Any remaining energy from the battery that is not required by the system is available to power the CHGIN.

### CHGIN Regulation Voltage

- In forward mode (when CHGIN is powered from a valid external source), CHGIN voltage is regulated to VCHGIN\_REG[4:0] when a high impedance or current limited source is applied. VCHGIN might experience significant voltage droop from the high-impedance source when the MAX77960/MAX77961 extract high power from the source. Regulating VCHGIN allows the MAX77960/MAX77961 to extract the most power from the power source. See the [Adaptive Input Current Limit \(AICL\) and Input Voltage Regulation](#) section for more detail.
- In reverse mode (OTG), CHGIN voltage is regulated to 5.1V with programmable current limit up to 3A (OTG\_ILIM[2:0]).

### SYS Regulation Voltage

With a valid external power source at CHGIN:

- When the DC-DC is disabled (MODE[3:0] = 0x00 or STBY\_EN = 0b1 or STBY pin = high), the Q<sub>BAT</sub> switch is fully on and V<sub>SYS</sub> = V<sub>BATT</sub> - I<sub>BATT</sub> × R<sub>BAT2SYS</sub>.
- When the DC-DC is enabled and the charger is disabled (MODE[3:0] = 0x04), V<sub>SYS</sub> is regulated to V<sub>BATTREG</sub> (CHG\_CV\_PRM) and Q<sub>BAT</sub> is off.
- When the DC-DC is enabled and the charger is enabled (MODE[3:0] = 0x05), but in a noncharging state such as Done, Thermistor Suspend, Watchdog Suspend, or Timer Fault, V<sub>SYS</sub> is regulated to V<sub>BATTREG</sub> (CHG\_CV\_PRM) and Q<sub>BAT</sub> is off.
- When the DC-DC is enabled and the charger is enabled (MODE[3:0] = 0x05) and in a valid charging state such as Precharge or Trickle Charge (V<sub>BATT</sub> < V<sub>SYSTEMIN</sub> - 500mV), V<sub>SYS</sub> is regulated to V<sub>BATTREG</sub> (CHG\_CV\_PRM). The charger operates as a linear regulator, and the power dissipation can be calculated with P = (V<sub>BATTREG</sub> - V<sub>BATT</sub>) × I<sub>BATT</sub>.
- When the DC-DC is enabled and the charger is enabled (MODE[3:0] = 0x05) and in a valid charging state such as Fast Charge (CC or CV) or Top-Off (V<sub>BATT</sub> > V<sub>SYSTEMIN</sub> - 500mV), the Q<sub>BAT</sub> switch is fully on, and V<sub>SYS</sub> = V<sub>BATT</sub> + I<sub>BATT</sub> × R<sub>BAT2SYS</sub>.

- In all the modes described above when the power demand on SYS exceeds the input source power limit, the battery automatically provides supplemental power to the system. If the Q<sub>BAT</sub> switch is initially off when V<sub>SYS</sub> drops to V<sub>BATT</sub> - V<sub>BSREG</sub>, the Q<sub>BAT</sub> switch turns on, and V<sub>SYS</sub> is regulated to V<sub>BATT</sub> - V<sub>BSREG</sub>.

Without a valid external power source at CHGIN, including with OTG mode (MODE[3:0] = 0x0A):

- The Q<sub>BAT</sub> switch is fully on, and V<sub>SYS</sub> = V<sub>BATT</sub> - I<sub>BATT</sub> × R<sub>BAT2SYS</sub>.

### Power States

The MAX77960/MAX77961 transition between power states as input/battery and load conditions dictate.

The MAX77960/MAX77961 provide four (4) power states and one (1) no power state. Under power limited conditions, the power path feature maintains SYS and USB-OTG loads at the expense of battery charge current. In addition, the battery supplements the input power when needed. See the [Smart Power Selector \(SPS\)](#) section for more details. As shown, transitions between power states are initiated by detection/removal of valid power sources, OTG events, and undervoltage conditions.

1. NO INPUT POWER, *MODE[3:0] = undefined*: No input adapter or battery is detected. The charger and system are off. Battery is disconnected.
2. BATTERY-ONLY, *MODE[3:0] = any mode*: CHGIN is invalid or outside the input voltage operating range. Battery is connected to power the SYS load (Q<sub>BAT</sub> = on).
3. NO CHARGE - DC-DC in FORWARD mode, *MODE[3:0] = 0x04*: CHGIN input is valid, DC-DC supplies power to SYS. DC-DC operates from a valid input. Battery is disconnected (Q<sub>BAT</sub> = off) when SYS load is less than the power that DC-DC can supply.
4. CHARGE - DC-DC in FORWARD mode, *MODE[3:0] = 0x05*: CHGIN input is valid, DC-DC supplies power to SYS and charges the battery with I<sub>BATT</sub>. DC-DC operates from a valid input.
5. OTG - DC-DC in REVERSE mode (OTG), *MODE[3:0] = 0x0A*: OTG is active. Battery is connected to support SYS and OTG loads (Q<sub>BAT</sub> = on), and charger operates in REVERSE buck mode.

### Powering Up with the Charger Disabled by Default

The MAX77960/MAX77961's default power state is CHARGE - DC-DC in FORWARD mode, MODE[3:0] = 0x05. For battery authentication/safety purposes, the MAX77960/MAX77961 can be configured to keep charging disabled while allowing the DC-DC to switch and regulate the SYS voltage when power is applied to CHGIN. To implement this and enable the charger when appropriate:

- Connect at least one of the INLIM, ITO, ISET or VSET pins to a valid resistor while tying the others (at least one) to PVL. CHG\_DTLS = 0x05 and CHG\_OK = 0.
- The system processor can configure the charger through the I<sup>2</sup>C interface.
- The system processor enables charging by setting COMM\_MODE to 1 (default is 0).

See [Wide-Input I<sup>2</sup>C Programmable Charger with Charger Disabled](#) for a pin connection example. Pin INLIM is connected to a valid resistor while ITO, ISET and VSET tie to PVL. The default input current limit is programmed by R<sub>INLIM</sub>, while default top-off current, constant charging current, and termination voltage use their default value. The system processor can re-program all four settings through the I<sup>2</sup>C interface if needed.

### Input Validation

The charger input is compared with several voltage thresholds to determine if it is valid. A charger input must meet the following characteristics to be valid:

- CHGIN must be above V<sub>CHGIN\_UVLO</sub> to be valid. Once CHGIN is above UVLO threshold, the information is latched and can only be reset when charger is in adaptive input current loop (AICL) and input current is lower than IULO threshold of 30mA.
- CHGIN must be below its overvoltage lockout threshold (V<sub>CHGIN\_OVLO</sub>).

The devices generate a CHGIN\_I interrupt (maskable with CHGIN\_M bit) when the CHGIN status changes. Read the CHGIN input status with CHGIN\_OK and CHGIN\_DTLS[1:0] register bits.

### Adaptive Input Current Limit (AICL) and Input Voltage Regulation

The MAX77960/MAX77961 feature input power management to extract maximum input power while avoiding input source overload. The adaptive input current limit (AICL) and the input voltage regulation (CHGIN\_REG) features allow the charger to extract more energy from relatively high resistance charge sources with long cables, noncompliant USB hubs or current limited adapters. In addition, the input power management allows the MAX77960/MAX77961 to perform well with adapters that have poor transient load responses.

With a high-resistance source, the charger input voltage drops substantially when it draws large current from the source. The charger's input voltage regulation loop automatically reduces the current drawn from the input to regulate the input voltage at V<sub>CHGIN\_REG</sub>. If the input current is reduced to I<sub>CHGIN\_REG\_OFF</sub> (50mA typ) and the input voltage is still below V<sub>CHGIN\_REG</sub>, the charger input turns off. V<sub>CHGIN\_REG</sub> is programmable with VCHGIN\_REG[4:0] register bits.

With a current limited source, if the MAX77960/MAX77961's input current limit is programmed above the current limit of the adapter, the charger input voltage starts to drop when the input current drawn exceeds the source current limit. The charger's input voltage regulation loop allows the MAX77960/MAX77961 to reduce its input current and operate at the current limit of the adapter.

When operating with the input voltage regulation loop active, an AICL\_I interrupt is generated, AICL\_OK sets to 0. The device prioritize system energy delivery over battery charging. See the [Smart Power Selector \(SPS\)](#) section for more details.

To extract most input power from a current limited charge source, monitor the AICL\_OK status while decreasing the CHGIN\_ILIM[6:0] register setting. Setting the CHGIN\_ILIM[6:0] to a reduced to a value below the current limit of the adapter causes the input voltage to rise. Although the CHGIN\_ILIM[6:0] is lowered, more power can be extracted from the adapter when the input voltage rises.

### Input Self-Discharge

To ensure that a rapid removal and reinsertion of a charge source always results in a charger input interrupt, the charger input presents loading to the input capacitor to ensure that when the charge source is removed, the input voltage decays below the UVLO threshold in a reasonable time (t<sub>INSD</sub>). The input self-discharge is implemented by with a 44kΩ resistor (R<sub>INSD</sub>) from CHGIN input to ground.

### System Self-Discharge with No Power

To ensure a timely, complete, repeatable, and reliable reset behavior when the system has no power, the MAX77960/MAX77961 actively discharge the BATT and SYS nodes when the adapter is missing, the battery is removed and V<sub>SYS</sub> is less than V<sub>SYSUVLO</sub>. The BATT and SYS discharge resistors are both 600Ω.

### Charger States

The MAX77960/MAX77961 utilize several charging states to safely and quickly charge batteries as shown in [Figure 1](#) and [Figure 2](#). [Figure 1](#) shows an exaggerated view of a Li+/Li-Poly battery progressing through the following charge states when there is no system load and the die and battery are close to room temperature: Prequalification → Fast-charge → Top-off → Done.

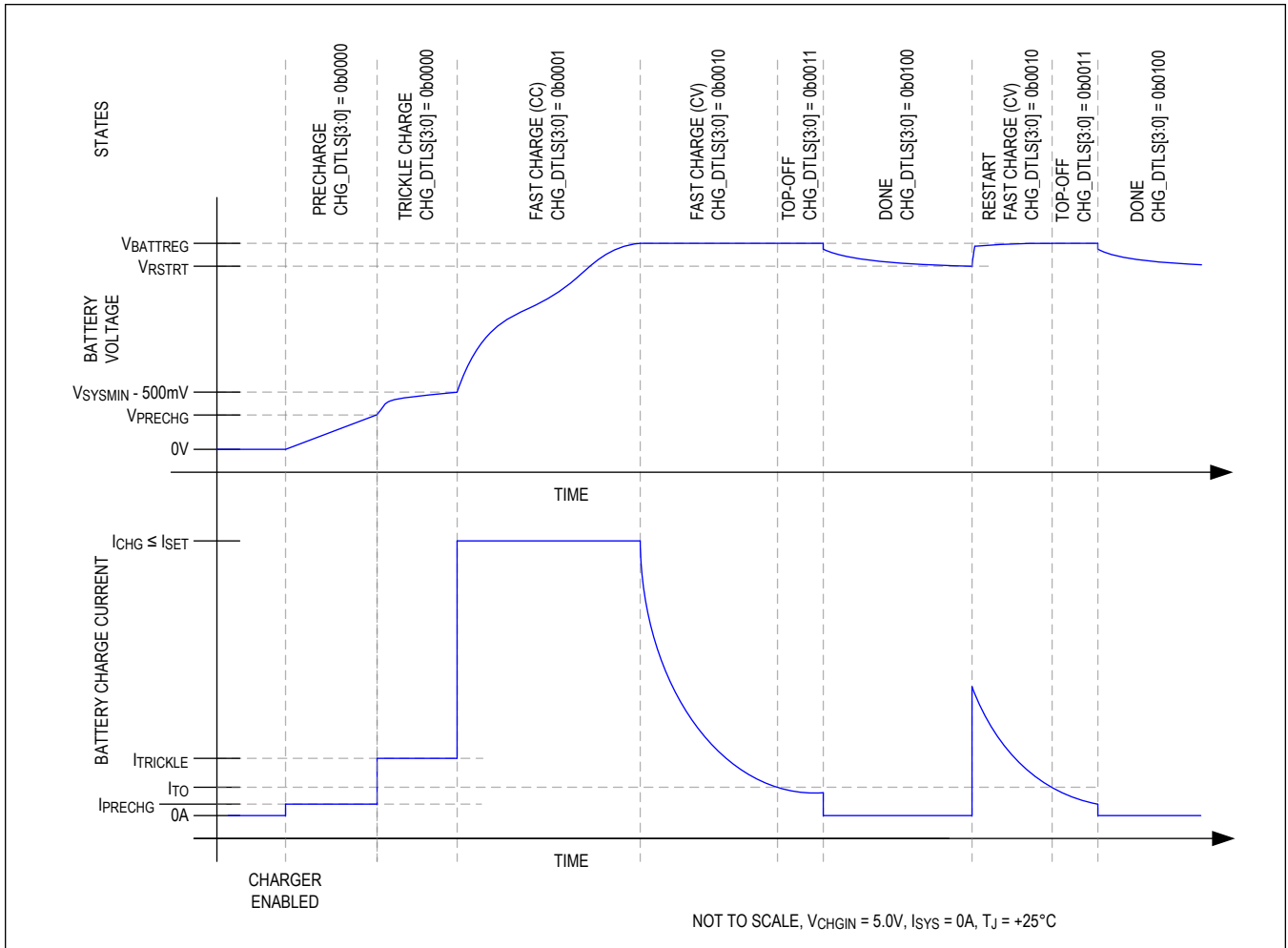

Figure 1. Li Battery Charge Profile

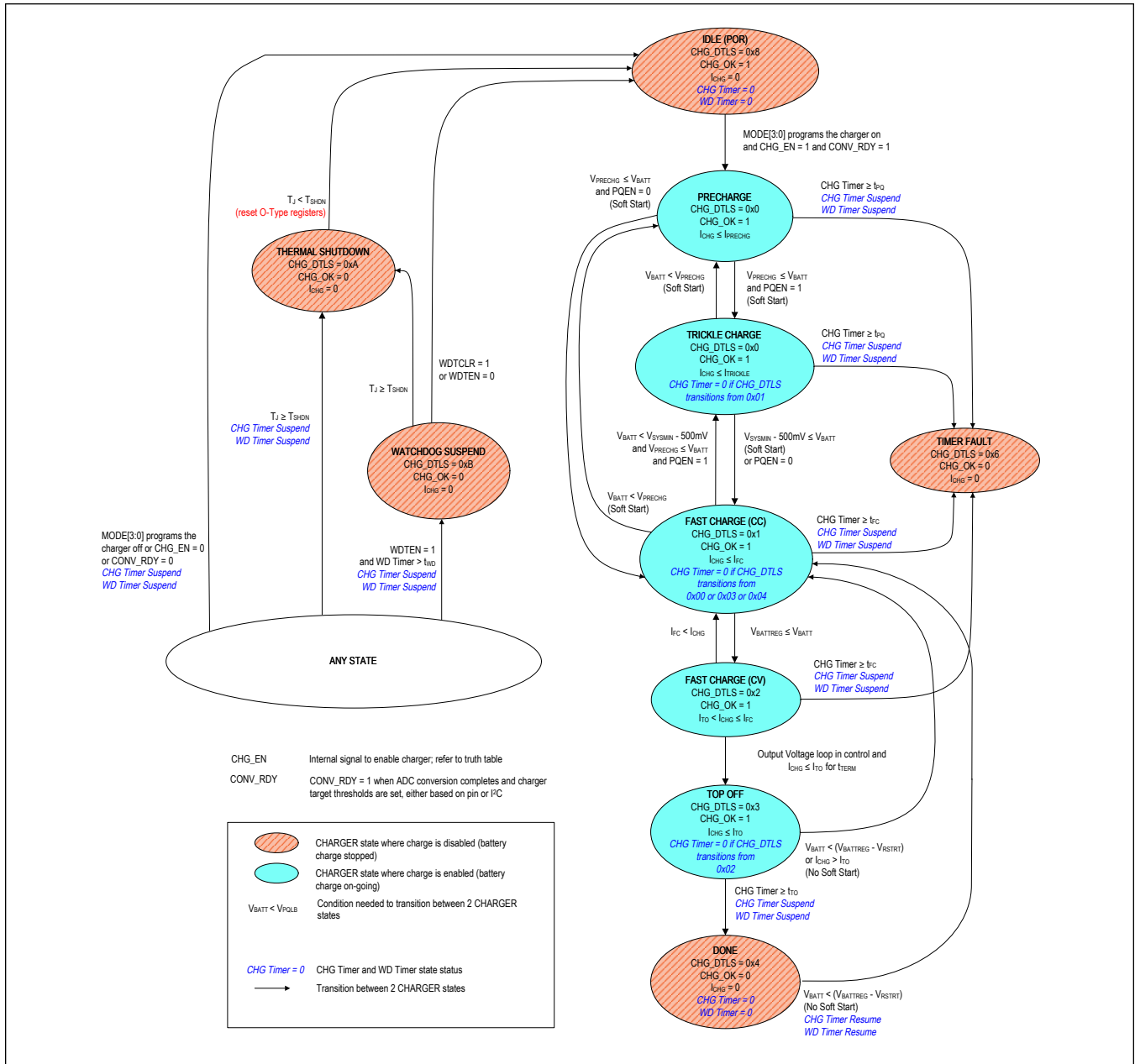

Figure 2. Charger State Diagram

**No Input Power or Charger Disabled Idle State**

From any state shown in Figure 2 except thermal shutdown, the no input power or charger disabled state is entered whenever the charger is programmed to be off or the charger input CHGIN is invalid. After being in this state for t<sub>SCIDG</sub>, CHG\_DTLS is set to 0x08 and CHG\_OK is set to 1. A CHG\_I interrupt is generated if CHG\_OK was 0 previously.

While in the no input power or charger disabled state, the charger current is 0mA, the watchdog and charge timers are forced to 0, and the power to the system is provided by either the battery or the adapter. When both battery and adapter power are available, the adapter provides primary power to the system and the battery contributes supplemental energy to the system if necessary.

To exit the no input power or charger disabled state, the charger input must be valid and the charger must be enabled.

### Precharge State

As shown in [Figure 2](#), the charger enters the precharge state when the battery voltage is less than  $V_{PRECHG}$ . After being in this state for  $t_{SCIDG}$ , a CHG\_I interrupt is generated if CHG\_OK was 0 previously, CHG\_OK is set to 1 and CHG\_DTLS is set to 0x00. In the precharge state, charge current into the battery is  $I_{PRECHG}$ .

The following events cause the state machine to exit this state:

- Battery voltage rises above  $V_{PRECHG}$  and the charger enters the next state in the charging cycle: Trickle Charge.
- If the battery charger remains in this state for longer than  $t_{PQ}$ , the charger state machine transitions to the Timer Fault state.
- If the watchdog timer is not serviced, the charger state machine transitions to the “Watchdog Suspend” state.

Note that the precharge state works with battery voltages down to 0V. The 0V operation typically allows this battery charger to recover batteries that have an open internal pack protector. Typically, a battery pack’s internal protection circuit opens if the battery has seen an overcurrent, undervoltage, or overvoltage. When a battery with an open internal pack protector is used with this charger, the precharge mode current flows into the 0V battery; this current raises the pack’s terminal voltage to the level where the internal pack protection switch closes.

Note that a normal battery typically stays in the precharge state for several minutes or less. Therefore a battery that stays in the precharge for longer than  $t_{PQ}$  might be experiencing a problem.

### Trickle Charge State

As shown in [Figure 2](#), the charger state machine is in trickle charge state when  $V_{PRECHG} < V_{BATT} < V_{SYSTEMIN} - 500mV$ . After being in this state for  $t_{SCIDG}$ , a CHG\_I interrupt is generated if CHG\_OK was 0 previously, CHG\_OK is set to 1 and CHG\_DTLS = 0x00.

With PQEN = 1 (default) and the MAX77960/MAX77961 are in the trickle charge state, the current in the battery is less than or equal to  $I_{TRICKLE}$ . When PQEN = 0, the charger skips trickle charge state and transitions directly to fast charge state and the battery charging current is less than or equal to  $I_{FC}$ .

Charge current may be less than  $I_{TRICKLE}/I_{FC}$  for any of the following reasons:

- The charger input is in input current limit.
- The charger input voltage is low.
- The charger is in thermal foldback.
- The system load is consuming adapter current. Note that the system load always gets priority over the battery charge current.

Typical systems operate with PQEN = 1. When operating with PQEN = 0, the system’s software usually sets  $I_{FC}$  to a low value such as 200mA and then monitors the battery voltage. When the battery exceeds a relatively low voltage such as 6V, then the system’s software usually increases  $I_{FC}$ .

The following events cause the state machine to exit this state:

- When the battery voltage rises above  $V_{SYSTEMIN} - 500mV$  or the PQEN bit is cleared, the charger enters the next state in the charging cycle: Fast Charge (CC).
- If the battery charger remains in this state for longer than  $t_{PQ}$ , the charger state machine transitions to the Timer Fault state.
- If the watchdog timer is not serviced, the charger state machine transitions to the Watchdog Suspend state.

Note that a normal battery typically stays in the trickle charge state for several minutes or less. Therefore, a battery that stays in trickle charge for longer than  $t_{PQ}$  might be experiencing a problem.

### Fast-Charge Constant Current State

As shown in [Figure 2](#), the charger enters the fast-charge constant current (CC) state when  $V_{SYSTEMIN} - 500mV$  (typ) <  $V_{BATT} < V_{BATTREG}$ . After being in the fast-charge CC state for  $t_{SCIDG}$ , a CHG\_I interrupt is generated if CHG\_OK was 0 previously, CHG\_OK is set to 1 and CHG\_DTLS = 0x01.

In the fast-charge CC state, the battery charging current is less than or equal to  $I_{FC}$ . Charge current can be less than  $I_{FC}$  for any of the following reasons:

- The charger input is in input current limit.
- The charger input voltage is low.
- The charger is in thermal foldback.
- The system load is consuming adapter current. Note that the system load always gets priority over the battery charging current.

The following events cause the state machine to exit this state:

- When the battery voltage rises above  $V_{\text{BATTREG}}$ , the charger enters the next state in the charging cycle: Fast Charge (CV).
- If the battery charger remains in this state for longer than  $t_{\text{FC}}$ , the charger state machine transitions to the Timer Fault state.
- If the watchdog timer is not serviced, the charger state machine transitions to the Watchdog Suspend state.

The battery charger dissipates the most power in the fast-charge constant current state, which causes the die temperature to rise. If the die temperature exceeds  $T_{\text{REG}}$ , the thermal foldback loop is engaged and  $I_{\text{FC}}$  is reduced. See the [Thermal Foldback](#) section for more information.

### Fast-Charge Constant Voltage State

As shown in [Figure 2](#), the charger enters the fast-charge constant voltage (CV) state when the battery voltage rises to  $V_{\text{BATTREG}}$  from the fast-charge CC state. After being in the fast-charge CV state for  $t_{\text{SCIDG}}$ , a CHG\_I interrupt is generated if CHG\_OK was 0 previously, CHG\_OK is set to 1 and CHG\_DTLS = 0x02.

In the fast-charge CV state, the battery charger maintains  $V_{\text{BATTREG}}$  across the battery and the charge current is less than or equal to  $I_{\text{FC}}$ . As shown in [Figure 1](#), charger current decreases exponentially in this state as the battery becomes fully charged.

The smart power selector control circuitry can reduce the charge current for any of the following reasons:

- The charger input is in input current limit.
- The charger input voltage is low.
- The charger is in thermal foldback.
- The system load is consuming adapter current. Note that the system load always gets priority over the battery charge current.

The following events cause the state machine to exit this state:

- When the charger current is below  $I_{\text{TO}}$  for  $t_{\text{TERM}}$ , the charger enters the [Top-Off State](#).
- If the battery charger remains in this state for longer than  $t_{\text{FC}}$ , the charger state machine transitions to the [Timer Fault State](#).
- If the watchdog timer is not serviced, the charger state machine transitions to the [Watchdog Timer Suspend State](#).

### Top-Off State

As shown in [Figure 2](#), the top-off state can only be entered from the fast-charge CV state when the charger current decreases below  $I_{\text{TO}}$  for  $t_{\text{TERM}}$ . After being in the top-off state for  $t_{\text{SCIDG}}$ , a CHG\_I interrupt is generated if CHG\_OK was 0 previously, CHG\_OK is set to 1, and CHG\_DTLS = 0x03. In the top-off state the battery charger maintains  $V_{\text{BATTREG}}$  across the battery and typically the charge current is less than or equal to  $I_{\text{TO}}$ .

The smart power selector control circuitry can reduce the charge current for any of the following reasons:

- The charger input is in input current limit.
- The charger input voltage is low.
- The charger is in thermal foldback.
- The system load is consuming adapter current. Note that the system load always gets priority over the battery charge current.

The following events cause the state machine to exit this state:

- After being in this state for the top-off time ( $t_{TO}$ ), the charger enters the [Done State](#).
- If  $V_{BATT} < V_{BATTREG} - V_{RSTRT}$ , the charger goes back to the [Fast-Charge Constant Current State](#).
- If the watchdog timer is not serviced, the charger state machine transitions to the [Watchdog Timer Suspend State](#).

### Done State

As shown in [Figure 2](#), the battery charger enters its done state after the charger has been in the top-off state for  $t_{TO}$ . After being in this state for  $t_{SCIDG}$ , a CHG\_I interrupt is generated only if CHG\_OK was 0 previously, CHG\_OK is set to 0 and CHG\_DTLS = 0x04.

The following events cause the state machine to exit this state:

- If  $V_{BATT} < V_{BATTREG} - V_{RSTRT}$ , the charger goes back to the [Fast-Charge Constant Current State](#).
- If the watchdog timer is not serviced, the charger state machine transitions to the [Watchdog Timer Suspend State](#).

In the done state, the battery charging current ( $I_{CHG}$ ) is 0A and the charger presents a very low load ( $I_{MBDN}$ ) to the battery. If the system load presented to the battery is low ( $\ll 100\mu A$ ), then a typical system can remain in the done state for many days. If left in the done state long enough, the battery voltage decays below the charging restart threshold ( $V_{RSTRT}$ ) and the charger state machine transitions back into the fast-charge CC state. There is no soft-start (di/dt limiting) during the done to fast-charge state transition.

### Timer Fault State

The battery charger provides both a charge timer and a watchdog timer to ensure safe charging. As shown in [Figure 2](#), the charge timer prevents the battery from charging indefinitely. The time that the charger is allowed to remain in its prequalification states is  $t_{PQ}$ . The time that the charger is allowed to remain in the fast-charge CC and CV states is  $t_{FC}$ , which is programmable with FCHGTIME. Finally the time that the charger is in the top-off state is  $t_{TO}$  which is programmable with TO\_TIME. Upon entering the timer fault state a CHG\_I interrupt is generated without a delay, CHG\_OK is cleared and CHG\_DTLS = 0x06.

The charger is off in the timer fault state. The charger can exit the timer fault state when the charger is programmed to be off then on again through the MODE bits or when DISQBAT pin is toggled from L-H-L. Alternatively, the charger input can be removed and reinserted to exit the timer fault state (see the ANY STATE bubble in [Figure 2](#)).

### Watchdog Timer Suspend State

The battery charger provides both a charge timer and a watchdog timer to ensure safe charging. As shown in [Figure 2](#), the watchdog timer protects the battery from charging indefinitely in the event that the host hangs or otherwise cannot communicate correctly. The watchdog timer is disabled by default with WDTEN = 0. Enable the feature by setting WDTEN = 1. With watchdog timer enabled, the host controller must reset the watchdog timer within the timer period ( $t_{WD}$ ) in order for the charger to operate properly. Reset the watchdog timer by programming WDTCLR = 0x01.

If the watchdog timer expires, charging stops, a CHG\_I interrupt is generated if CHG\_OK was 1 previously, CHG\_OK is cleared, and CHG\_DTLS indicates that the charger is off because the watchdog timer expired. Once the watchdog timer expires, the charger can be restarted by programming WDTCLR = 0x01. The SYS node can be supported by the battery and/or the adapter through the DC-DC buck while the watchdog timer is expired.

### Thermal Shutdown State

As shown in [Figure 2](#), the state machine enters the thermal shutdown state when the junction temperature ( $T_J$ ) exceeds the device's thermal shutdown threshold ( $T_{SHDN}$ ). When  $T_J$  is close to  $T_{SHDN}$ , the charger would have already folded back the input current to 0A, (see the [Thermal Foldback](#) section for more details), so the charger and the DC-DC are effectively off. Upon entering this state, CHG\_I interrupt is generated if CHG\_OK was 1 previously, CHG\_OK is cleared, and CHG\_DTLS = 0x0A.

In the thermal shutdown state, the charger is off. MODE register (CHG\_CNFG\_00[3:0]) is reset to its default value as well as all O-type registers.

**Thermal Management**

The MAX77960/MAX77961 charger use several thermal management techniques to prevent excessive battery and die temperatures.

**Thermal Foldback**

Thermal foldback maximizes the battery charge current while regulating the MAX77960/MAX77961 junction temperature. As shown in [Figure 3](#), when the die temperature exceeds the value programmed by REGTEMP (T<sub>REG</sub>), a thermal limiting circuit reduces the battery charger’s target current by 5%/°C (A<sub>TJREG</sub>) with an analog control loop. When the charger transitions in and out of the thermal foldback loop, a CHG\_I interrupt is generated and the host microprocessor can read the status of the thermal regulation loop with the TREG status bit. Note that an active thermal foldback loop is not an abnormal operation and the thermal foldback loop status does not affect the CHG\_OK bit (only information contained within CHG\_DTLS affects CHG\_OK).

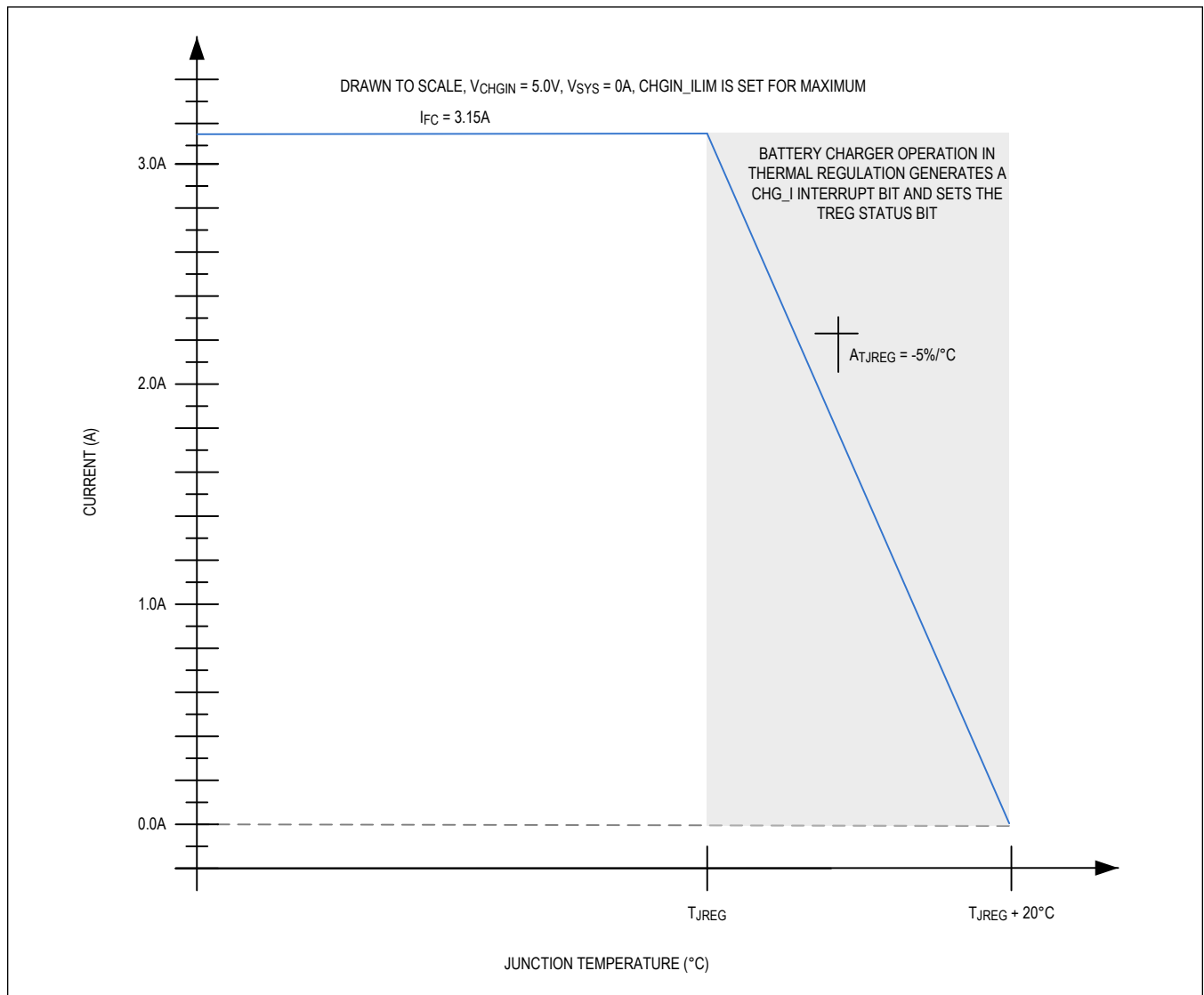

Figure 3. Charge Currents vs. Junction Temperature

**JEITA Compliance**

The MAX77960/MAX77961 safely charge Li+ batteries in accordance with JEITA specifications. The MAX77960/MAX77961 monitor the battery temperature with a NTC thermistor connected at THM pin and automatically adjust the fast-charge current and/or charge termination voltage as the battery temperature varies. JEITA-controlled charging can be disabled by setting JEITA\_EN to 0. CHG\_DTLS and THM\_DTLS registers report JEITA-controlled charging status.

The JEITA controlled fast-charging current (I<sub>CHGCC\_JEITA</sub>) and charge termination voltage (V<sub>CHGCV\_JEITA</sub>) for T<sub>COLD</sub> < T < T<sub>COOL</sub> are programmable with I<sup>2</sup>C bits I<sub>CHGCC\_COOL</sub> and V<sub>CHGCV\_COOL</sub>.

The charge termination voltage for T<sub>WARM</sub> < T < T<sub>HOT</sub> is reduced to (CHG\_CV\_PRM - 180mV/cell), as shown in [Figure 4](#).

Charging is suspended when the battery temperature is too cold or too hot (T < T<sub>COLD</sub> or T<sub>HOT</sub> < T).

Temperature thresholds (T<sub>COLD</sub>, T<sub>COOL</sub>, T<sub>WARM</sub>, and T<sub>HOT</sub>) depend on the thermistor selection. See the [Thermistor Input \(THM\)](#) section for more details.

When battery charge current is reduced by 50%, the charger timer is doubled.

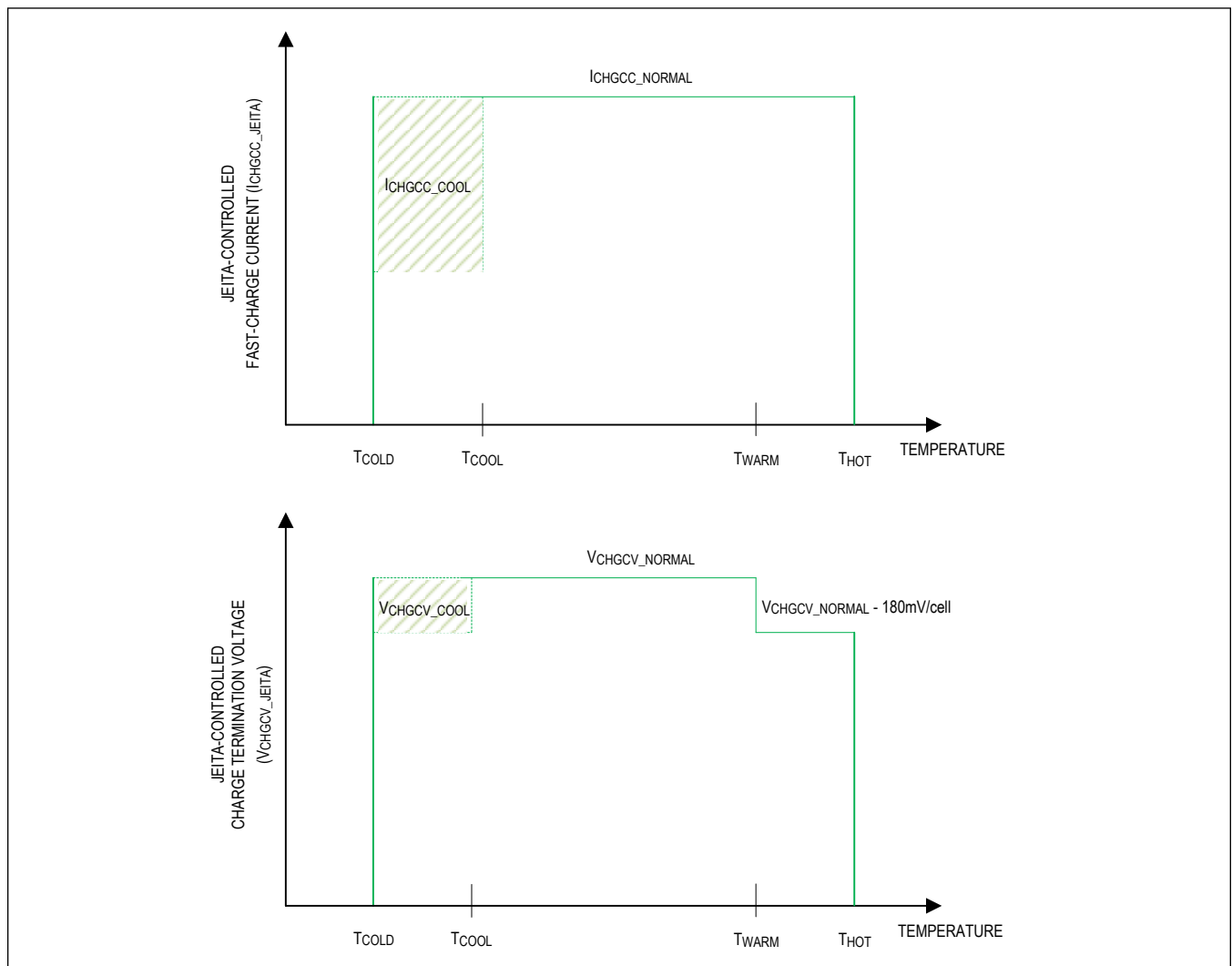

Figure 4. JEITA Compliance

**Thermal Shutdown**

The MAX77960/MAX77961 have a die temperature sensing circuit. When the die temperature exceeds the thermal shutdown threshold, T<sub>SHDN</sub>, the MAX77960/MAX77961 shut down and reset O-type I<sup>2</sup>C registers. There is a 15°C thermal hysteresis. After thermal shutdown, if the die temperature reduces by 15°C, the thermal shutdown bus deasserts and the devices reenables. The battery charger has an independent thermal regulation loop. See the [Thermal Shutdown State](#) section for more details.

**Factory Ship Mode**

The MAX77960/MAX77961 support factory ship mode with low battery quiescent current, I<sub>SHDN</sub>.

When the input source is not valid, and the device is powered by battery, the devices enter factory ship mode if DISQBAT is pulled high or FSHIP\_MODE bit is set to 1. I<sup>2</sup>C communication is unavailable in factory ship mode. When a valid input source is applied to the device's CHGIN pin, the devices exit factory ship mode. I<sup>2</sup>C communication is enabled, charging is enabled if all conditions to charge are met (e.g., DISQBAT pin is pulled low and MODE[3:0] = 0x05).

**Minimum System Voltage**

The system voltage is regulated to the minimum SYS voltage (V<sub>SYSTEMIN</sub>) when the battery is low (V<sub>BATT</sub> < V<sub>SYSTEMIN</sub> - 500mV).

- The charging current is I<sub>PRECHG</sub> when V<sub>BATT</sub> < V<sub>PRECHG</sub>.
- The charging current is I<sub>TRICKLE</sub> when V<sub>PRECHG</sub> < V<sub>BATT</sub> < V<sub>SYSTEMIN</sub> - 500mV.
- The charging current is I<sub>FC</sub> when V<sub>SYSTEMIN</sub> - 500mV < V<sub>BATT</sub>.

**Battery Differential Voltage Sense (BATSP, BATSN)**

BATSP and BATSN are differential remote voltage sense lines for the battery. The MAX77960/MAX77961's remote sensing feature improves voltage sense accuracy, maximizes charging time in Fast-Charge CC State and thus minimizes total charging time. The thermistor voltage is interpreted with respect to BATSN. For best results, connect BATSP and BATSN as close as possible to the battery connector.

**Battery Overcurrent Alert**

Excessive battery discharge current can occur for several reasons such as exposure to moisture, a software problem, an IC failure, a component failure, or a mechanical failure that causes a short circuit. The battery overcurrent alert feature is enabled with B2SOVRC[3:0]; disabling this feature reduces the battery current consumption by I<sub>BOVRC</sub>.

When the battery (BATT) to system (SYS) discharge current (I<sub>BATT</sub>) exceeds the programmed overcurrent threshold for at least t<sub>BOVRC</sub>, the Q<sub>BAT</sub> switch closes to reduce the power loss in the MAX77960/MAX77961. A B2SOVRC\_I and a BAT\_I interrupt are generated, BAT\_OK is cleared, and BAT\_DTLS reports an overcurrent condition. Typically, when the host processor detects this overcurrent interrupt, it executes a housekeeping routine that tries to mitigate the overcurrent situation. If the processor cannot correct the overcurrent within t<sub>OCP</sub>, then the MAX77960/MAX77961 turn off the DC-DC.

t<sub>OCP</sub> time duration can be set through the B2SOVRC\_DTC register bit (Battery to SYS Overcurrent Debounce Time Control): 0x0 (dflt): t<sub>OCP</sub> = 6ms, 0x1: t<sub>OCP</sub> = 100ms.

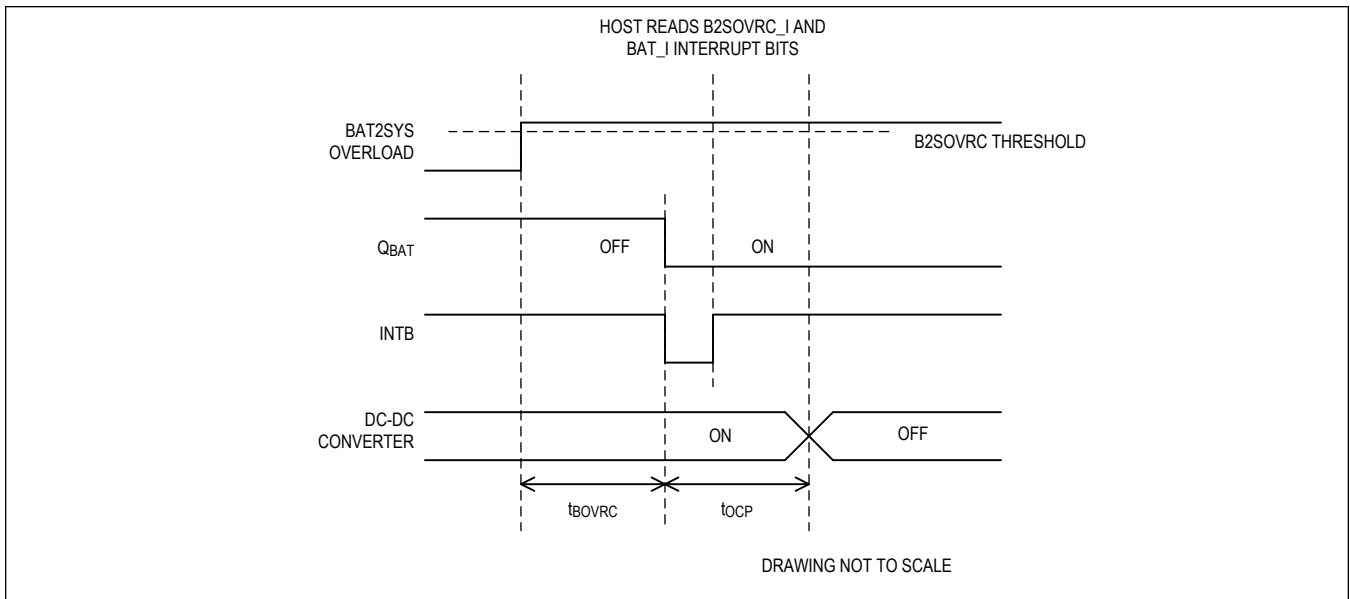

Figure 5. B2SOVRC

**Charger Interrupt Debounce Time**

**Table 9. List of Charger Interrupt Debounce Time**

INTERRUPT	DEBOUNCE TIME			
	RISING		FALLING	
	MIN	MAX	MIN	MAX
AICL_I	30ms	—	30ms	—
CHGIN_I	7ms	—	None	—
B2SOVRC_I	—	3.3ms	None	—
BAT_I (OV)	30ms	—	None	—
OTG_PLIM_I (OTG Fault)	37.5ms	—	None	—
OTG_PLIM_I (Buck-Boost Positive Current Limit)	450µs	—	None	—

**Input Power-OK/OTG Power-OK Output (INOKB)**

INOKB is an open-drain and active-low output that indicates CHGIN power-OK status.

When OTG mode is disabled, (OTGEN = low and MODE[3:0] ≠ 0x0A), INOKB pulls low when a valid input source is inserted at CHGIN,  $V_{CHGIN\_UVLO} < V_{CHGIN} < V_{CHGIN\_OVLO}$ .

When OTG mode is enabled, (OTGEN = high or MODE[3:0] = 0x0A), INOKB pulls low to indicate the OTG output power OK when  $V_{CHGIN.OTG.UV} < V_{CHGIN} < V_{CHGIN.OTG.OV}$ .

INOKB can be used as a logic output by adding a 200kΩ pullup resistor to a system IO voltage.

INOKB can be also used as a LED indicator driver by adding a current limiting resistor and a LED to a pullup voltage source.

**Charge Status Output (STAT)**

STAT is an open-drain and active-low output that indicates charge status. STAT can be used as a logic input to the host processor by adding a 200kΩ pullup resistor to a system IO rail and a rectifier (a diode and a capacitor).

**Table 10. Charge Status Indicator by STAT**

CHARGE STATUS	STAT	LOGIC STATE
No input	High impedance	High
No DC-DC/no charge: valid adapter with STBY_EN = 1 or MODE = 0x0/1/2/3/4	High impedance	High
Trickle, precharge, fast charge	Repeat low and high impedance with 1Hz, 50% duty cycle	High, rectified with an external diode and a capacitor
Top-off and done	Low	Low
Faults	High impedance	High

**Reverse Buck Mode (OTG)**

The DC-DC converter topology of the MAX77960/MAX77961 allows it to operate as a forward buck-boost converter or as a reverse buck converter. The modes of the DC-DC converter are controlled with MODE[3:0] register bits. When MODE[3:0] = 0x0A or OTGEN = high, the DC-DC converter operates in reverse buck mode, allowing it to source current to CHGIN, commonly referred to as USB OTG mode.

In OTG mode, the DC-DC converter operates in reverse buck mode and regulates V<sub>CHGIN</sub> to V<sub>CHGIN.OTG</sub> (5.1V typ). The current through the CHGIN current-sensing resistor (CSINN, CSINP) is limited to the value programmed by OTG\_ILIM[2:0]. There are eight OTG\_ILIM options to program CHGIN current limit from 500mA to 3A. When the OTG mode is enabled, the unipolar CHGIN transfer function measures current going out of CHGIN. When OTG mode is disabled, the unipolar CHGIN transfer function measures current going into CHGIN.

OTG\_I, OTG\_M, OTG\_OK are the interrupt bit, interrupt mask bit and interrupt status bit associated with OTG function. OTG\_DTLS[1:0] reports the status of the OTG operation. OTG\_DTLS[1:0] is latched until the host reads the register.

If the external OTG load at CHGIN exceeds I<sub>CHGIN.OTG.ILIM</sub> current limit for a minimum of 37.5ms, an OTG\_I interrupt is generated, OTG\_OK = 0 and OTG\_DTLS[1:0] = 01. The reverse buck operates as a current limited voltage source when overloaded. The DC-DC converter stops switching when the OTG\_ILIM condition lasts for 60ms and automatically resumes switching after 300ms off time. If the OTG\_ILIM fault condition at CHGIN persists, the DC-DC toggles on and off with ~60ms on and ~300ms off.

VBUS is normally an external-facing pin in the application, and it might have a risk of being shorted to GND. In this case, the MAX77960/MAX77961 can experience a short-circuit condition at its output. If such risk is real, it is recommended to add a current-limited load switch at VBUS for overcurrent protection. The load switch guarantees the OTG output current does not exceed its current limit under any circumstances. The current limit should be set no lower than I<sub>CHGIN.OTG.ILIM</sub> of the MAX77960/MAX77961.

When CHGIN voltage drops below V<sub>CHGIN.OTG.UVLO</sub>, the DC-DC stops switching and an OTG\_I interrupt is generated. OTG\_OK = 0 and OTG\_DTLS[1:0] = 00.

When CHGIN voltage exceeds V<sub>CHGIN.OTG.OV</sub>, the DC-DC stops switching and an OTG\_I interrupt is generated. OTG\_OK = 0 and OTG\_DTLS[1:0] = 10.

If the DC-DC stops switching due to a OTG\_UV or OTG\_OV fault condition, it automatically retries after 300ms off time.

INOKB is the hardware indication of the OTG power good. See the [Input Power-OK/OTG Power-OK Output \(INOKB\)](#) section for details.

**OTG Enable (OTGEN)**

The OTGEN is an active high input. When OTGEN pin is pulled high, the OTG function is enabled. When the OTGEN pin is pulled low, the OTG function can be enabled through I<sup>2</sup>C by setting MODE[3:0] = 0x0A. To pull the OTGEN pin low with a pulldown resistor, the resistance must be lower than 44kΩ.

The devices enable reverse buck operation only when the voltage on the CHGIN bypass cap, V<sub>CHGIN</sub>, falls below V<sub>CHGIN\_UVLO</sub>.

In case V<sub>CHGIN</sub> is above V<sub>CHGIN\_UVLO</sub> threshold at the OTG enable, the devices ensure V<sub>CHGIN</sub> node discharge through a 8kΩ pulldown resistor before enabling the OTG function and reverse buck switching.

Pulldown is released once V<sub>CHGIN\_UVLO</sub> is reached.

### Analog Low-Noise Power Input (AVL)

AVL is the power input for the MAX77960/MAX77961's analog circuitry. Do not power external devices from this pin. Bypass with a 4.7Ω resistor between AVL and PVL and a 4.7μF capacitor from AVL to GND.

### Low-Side Gate Driver Power Supply (PVL)

PVL is an internal 1.8V LDO output that powers the MAX77960/MAX77961's low-side gate driver circuitry. Do not power external devices other than pullup resistors from this pin. Bypass with a 4.7μF capacitor to GND.

## System Faults

### V<sub>SYS</sub> Fault

The MAX77960/MAX77961 monitor the V<sub>SYS</sub> node for undervoltage and overvoltage events. The following sections describe the devices' behavior if any of these events is to occur.

#### V<sub>SYS</sub> Undervoltage Lockout (V<sub>SYSUVLO</sub>)

When the voltage from SYS to GND (V<sub>SYS</sub>) is less than the undervoltage lockout threshold (V<sub>SYSUVLO</sub>), the MAX77960/MAX77961 generate a SYSUVLO\_I interrupt immediately. If V<sub>SYS</sub> is undervoltage for greater than 8ms, the device shuts down and resets O-type I<sup>2</sup>C registers.

#### V<sub>SYS</sub> Overvoltage Lockout (V<sub>YSOVL</sub>)

When the V<sub>SYS</sub> exceeds V<sub>YSOVL</sub>, the MAX77960/MAX77961 generate a YSOVL\_I interrupt immediately and the device shuts down and resets O-type I<sup>2</sup>C registers.

### Thermal Fault

The MAX77960/MAX77961 have a die temperature sensing circuit. When the die temperature exceeds the thermal shutdown threshold, 165°C (T<sub>SHDN</sub>), the MAX77960/MAX77961 shut down and reset O-type I<sup>2</sup>C registers. There is a 15°C thermal hysteresis. After thermal shutdown, if the die temperature reduces by 15°C, the thermal shutdown bus deasserts and IC reenables. The battery charger has an independent thermal regulation loop. See the [Thermal Foldback](#) section for more details.

## Register Types and Reset Conditions

The IC has different levels of reset as defined below:

- S-type: registers are reset each time when: V<sub>AVL</sub> < 1.8V. S-type registers include TOP registers from 0x00 to 0x04; CHARGER\_FUNC registers 0x10, 0x12, 0x13, 0x14, 0x15.
- O-type: registers are reset each time when: V<sub>AVL</sub> < 1.8V or V<sub>SYS</sub> < V<sub>SYSUVLO</sub> or V<sub>SYS</sub> > V<sub>YSOVL</sub> or die temperature > T<sub>SHDN</sub> or software reset (SW\_RST). O-type registers include CHARGER\_FUNC registers 0x11, and all registers from 0x16 to 0x20.

### Charger Register Write Protection

CHG\_CNFG register 1, 2, 3, 4, 7, 8, 9 (CHARGER\_FUNC register address 0x17, 0x18, 0x19, 0x1A, 0x1D, 0x1E, 0x1F) are protected by CHG\_CNFG\_06.CHGPROT bitfield. By default, these configurations are not writable, and need unlocking by writing bitfield CHGPROT = 0x3 first.

### Interrupt Output (INTB)

The INTB is an active-low, open-drain output. Connect a pullup resistor to the pullup power source.

The MAX77960/MAX77961's INTB can be connected to the host's interrupt input and signals to the host when unmasked interrupt events occur within the MAX77960/MAX77961.

## I<sup>2</sup>C Serial Interface

The I<sup>2</sup>C serial bus consists of a bidirectional serial-data line (SDA) and a serial clock (SCL). I<sup>2</sup>C is an open-drain bus. SDA and SCL require pullup resistors (500Ω or greater). Optional 24Ω resistors in series with SDA and SCL help

to protect the device inputs from high-voltage spikes on the bus lines. Series resistors also minimize crosstalk and undershoot on bus lines.

### System Configuration

The I<sup>2</sup>C bus is a multimaster bus. The maximum number of devices that can attach to the bus is only limited by bus capacitance.

Figure 6 shows an example of a typical I<sup>2</sup>C system. A device on I<sup>2</sup>C bus that sends data to the bus is called a transmitter. A device that receives data from the bus is called a receiver. The device that initiates a data transfer and generates SCL clock signals to control the data transfer is a master. Any device that is being addressed by the master is considered a slave. When the MAX77960/MAX77961 I<sup>2</sup>C-compatible interface is operating, it is a slave on I<sup>2</sup>C bus and it can be both a transmitter and a receiver.

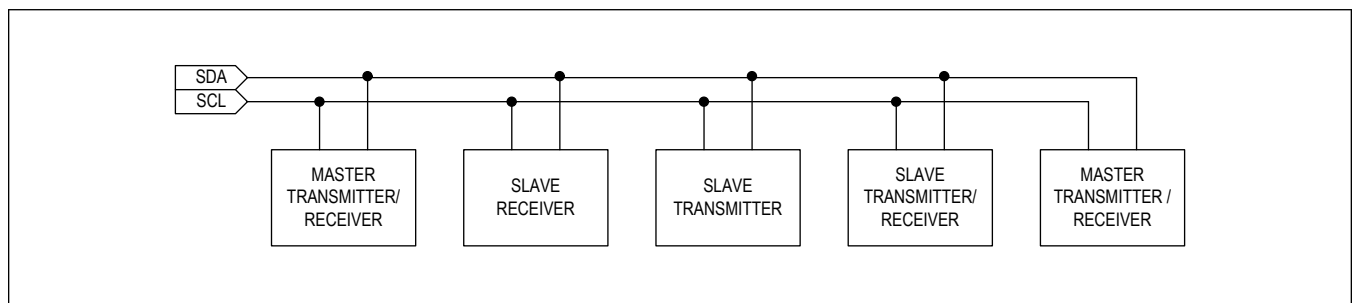

Figure 6. Functional Logic Diagram for Communications Controller

### Bit Transfer

One data bit is transferred for each SCL clock cycle. The data on SDA must remain stable during the high portion of SCL clock pulse. Changes in SDA while SCL is high are control signals (START and STOP conditions).

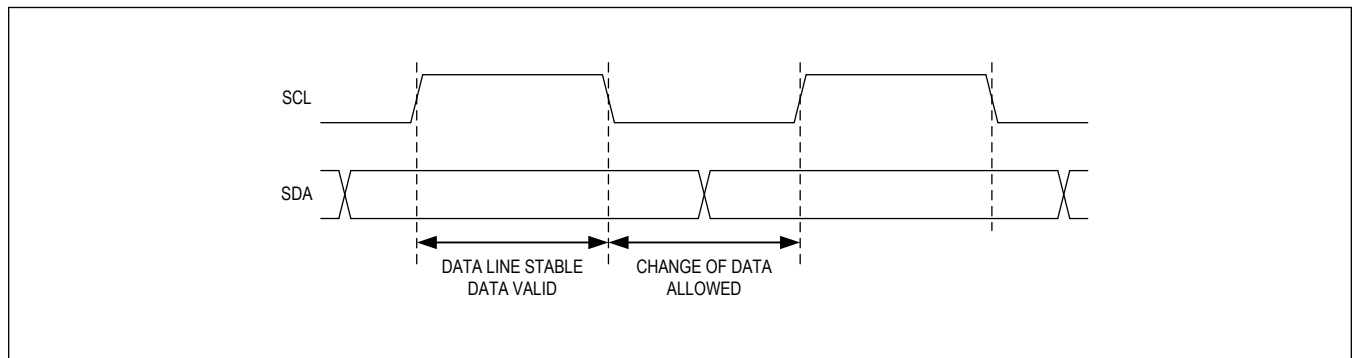

Figure 7. I<sup>2</sup>C Bit Transfer

### START and STOP Conditions

When I<sup>2</sup>C serial interface is inactive, SDA and SCL idle high. A master device initiates communication by issuing a START condition. A START condition is a high-to-low transition on SDA with SCL high. A STOP condition is a low-to-high transition on SDA, while SCL is high.

A START condition from the master signals the beginning of a transmission to the IC. The master terminates transmission by issuing a NOT ACKNOWLEDGE followed by a STOP condition.

A STOP condition frees the bus. To issue a series of commands to the slave, the master can issue REPEATED START (Sr) commands instead of a STOP command in order to maintain control of the bus. In general, a REPEATED START command is functionally equivalent to a regular START command.

When a STOP condition or incorrect address is detected, the ICs internally disconnect SCL from the I<sup>2</sup>C serial interface

until the next START condition, minimizing digital noise and feed-through.

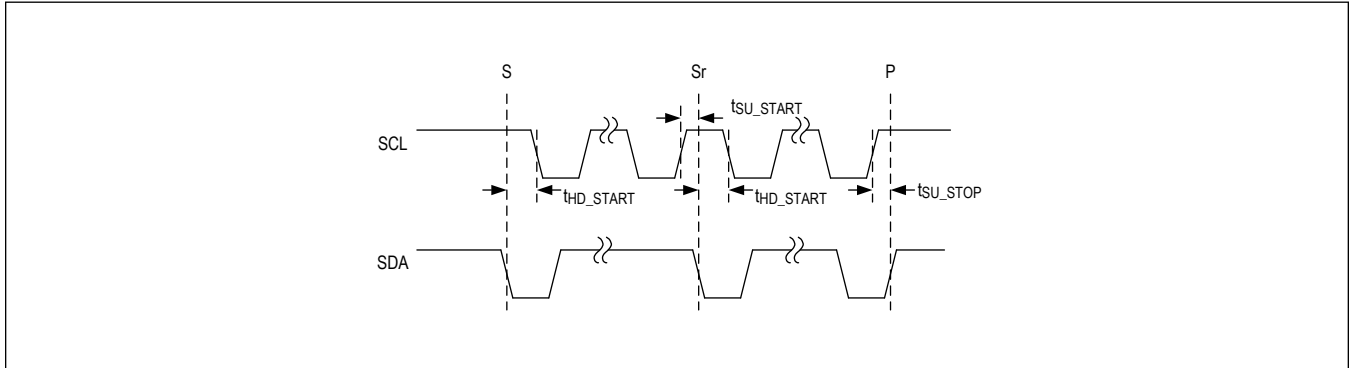

Figure 8. I<sup>2</sup>C Start Stop

### Acknowledge

Both the I<sup>2</sup>C bus master and the IC (slave) generate acknowledge bits when receiving data. The acknowledge bit is the last bit of each nine bit data packet. To generate an ACKNOWLEDGE (A), the receiving device must pull SDA low before the rising edge of the acknowledge-related clock pulse (ninth pulse) and keep it low during the high period of the clock pulse. To generate a NOT-ACKNOWLEDGE (nA), the receiving device allows SDA to be pulled high before the rising edge of the acknowledge-related clock pulse and leaves it high during the high period of the clock pulse.

Monitoring the acknowledge bits allows for detection of unsuccessful data transfers. An unsuccessful data transfer occurs if a receiving device is busy or if a system fault has occurred. In the event of an unsuccessful data transfer, the bus master should reattempt communication at a later time.

### Slave Address

The devices act as a slave transmitter/receiver. The slave address of the IC is 0xD2h/0xD3h. The least significant bit is the read/write indicator (1 for read, 0 for write).

### Clock Stretching

In general, the clock signal generation for I<sup>2</sup>C bus is the responsibility of the master device. I<sup>2</sup>C specification allows slow slave devices to alter the clock signal by holding down the clock line. The process in which a slave device holds down the clock line is typically called clock stretching. The IC does not use any form of clock stretching to hold down the clock line.

### General Call Address

The devices do not implement an I<sup>2</sup>C specification general call address. If the devices see a general call address (0000000b), they do not issue an ACKNOWLEDGE (A).

### Communication Speed

The devices provide I<sup>2</sup>C 3.0-compatible (1MHz) serial interface.

- I<sup>2</sup>C Revision 3 Compatible Serial Communications Channel
  - 0Hz to 100kHz (standard mode)
  - 0Hz to 400kHz (fast mode)
  - 0Hz to 1MHz (fast-mode plus)
- Does not utilize I<sup>2</sup>C clock stretching

Operating in standard mode, fast mode, and fast-mode plus does not require any special protocols. The main consideration when changing the bus speed through this range is the combination of the bus capacitance and pullup resistors. Higher time constants created by the bus capacitance and pullup resistance ( $C \times R$ ) slow the bus operation. Therefore, when increasing bus speeds the pullup resistance must be decreased to maintain a reasonable time constant.

Refer to the *Pullup Resistor Sizing* section of the I<sup>2</sup>C revision 3.0 specification for detailed guidance on the pullup resistor selection. In general, for bus capacitance of 200pF, a 100kHz bus needs 5.6kΩ pullup resistors, a 400kHz bus needs about a 1.5kΩ pullup resistors, and a 1MHz bus needs 680Ω pullup resistors. Note that the pullup resistor dissipates power when the open-drain bus is low. The lower the value of the pullup resistor, the higher the power dissipation ( $V^2/R$ ).

Operating in high-speed mode requires some special considerations. For the full list of considerations, refer to the I<sup>2</sup>C 3.0 specification. The major considerations with respect to the IC are:

- I<sup>2</sup>C bus master uses current source pullups to shorten the signal rise times.
- I<sup>2</sup>C slave must use a different set of input filters on its SDA and SCL lines to accommodate for the higher bus speed.
- The communication protocols need to utilize the high-speed master code.

At power-up and after each STOP condition, the IC input filters are set for standard mode, fast mode, or fast-mode plus (i.e., 0Hz to 1MHz). To switch the input filters for high-speed mode, use the high-speed master code protocols that are described in the *Communication Protocols* section.

### Communication Protocols

The devices support both writing and reading from their registers.

#### Writing to a Single Register

Figure 9 shows the protocol for the I<sup>2</sup>C master device to write one byte of data to the ICs. This protocol is the same as SMBus specification's Write Byte protocol.

The Write Byte protocol is as follows:

1. The master sends a START command (S).
2. The master sends the 7-bit slave address followed by a write bit ( $R/\bar{W} = 0$ ).
3. The addressed slave asserts an ACKNOWLEDGE (A) by pulling SDA low.
4. The master sends an 8-bit register pointer.
5. The slave acknowledges the register pointer.
6. The master sends a data byte.
7. The slave acknowledges the data byte. At the rising edge of SCL, the data byte is loaded into its target register and the data becomes active.
8. The master sends a STOP condition (P) or a REPEATED START condition (Sr). Issuing a P ensures that the bus input filters are set for 1MHz or slower operation. Issuing a REPEATED START (Sr) leaves the bus input filters in their current state.

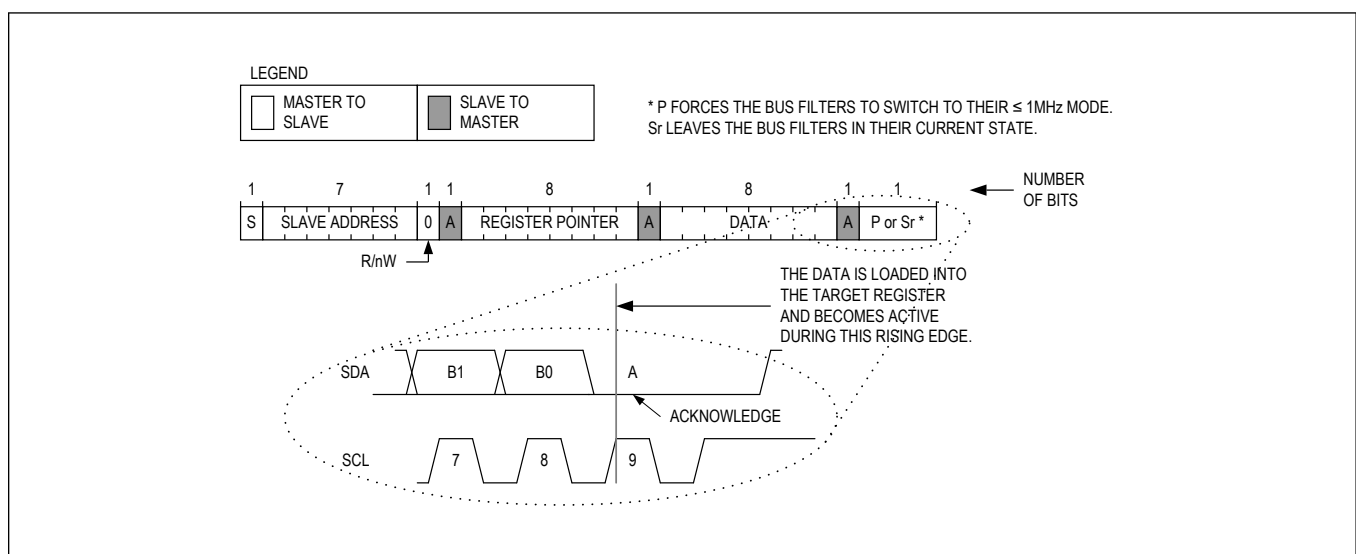

Figure 9. Writing to a Single Register

**Writing to Sequential Registers**

Figure 10 shows the protocol for writing to sequential registers. This protocol is similar to the Write Byte protocol, except the master continues to write after it receives the first byte of data. When the master is done writing, it issues a STOP or REPEATED START.

The Writing to Sequential Registers protocol is as follows:

1. The master sends a START command (S).
2. The master sends the 7-bit slave address followed by a write bit ( $R/\bar{W} = 0$ ).
3. The addressed slave asserts an ACKNOWLEDGE (A) by pulling SDA low.
4. The master sends an 8-bit register pointer.
5. The slave acknowledges the register pointer.
6. The master sends a data byte.
7. The slave acknowledges the data byte. At the rising edge of SCL, the data byte is loaded into its target register and the data becomes active.
8. Steps 6 to 7 are repeated as many times as the master requires.
9. During the last acknowledge related clock pulse, the slave issues an ACKNOWLEDGE (A).
10. The master sends a STOP condition (P) or a REPEATED START condition (Sr). Issuing a P ensures that the bus input filters are set for 1MHz or slower operation. Issuing a REPEATED START (Sr) leaves the bus input filters in their current state.

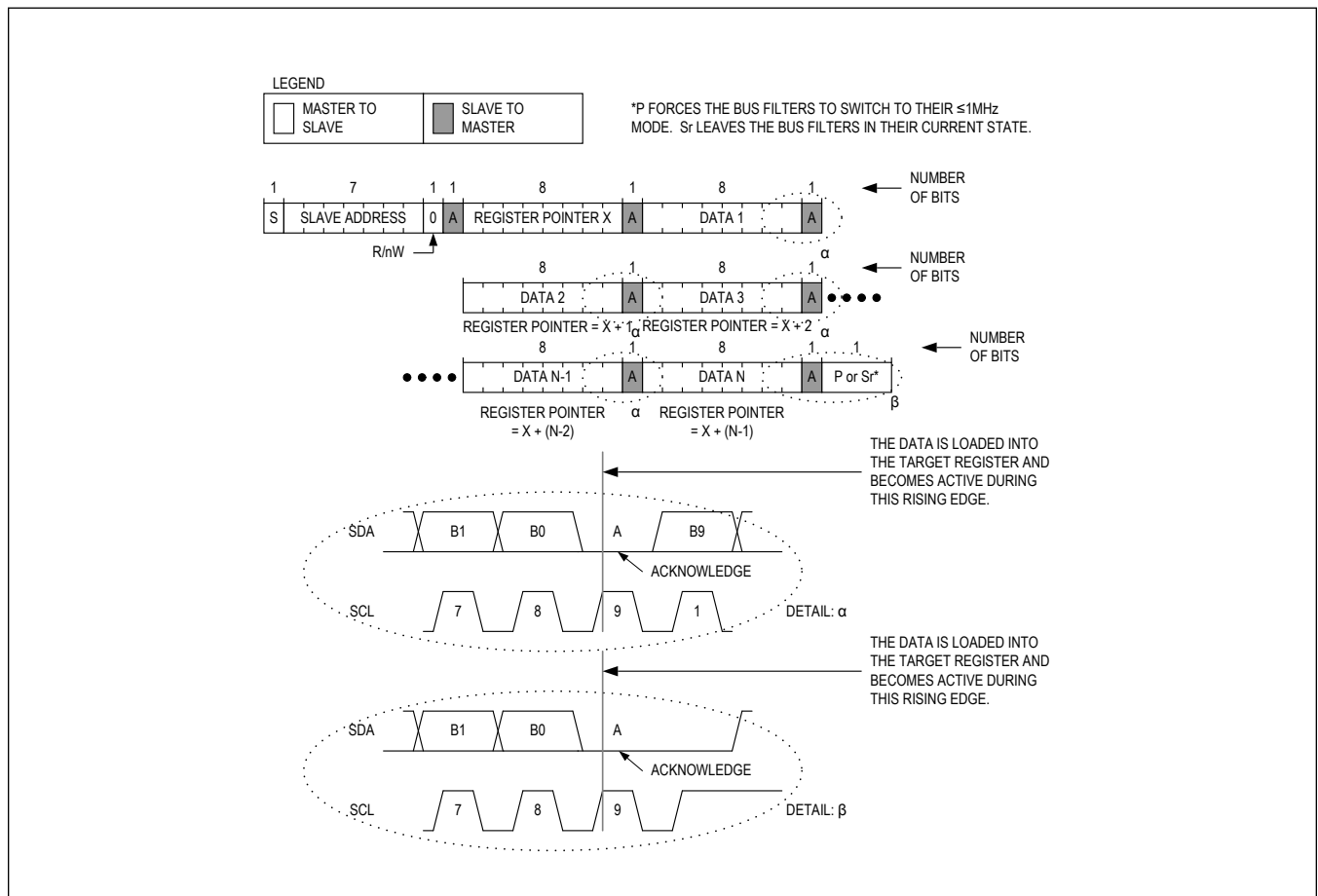

Figure 10. Writing to Sequential Registers

**Writing Multiple Bytes using Register-Data Pairs**

Figure 11 shows the protocol for the I<sup>2</sup>C master device to write multiple bytes to the devices using register data pairs. This protocol allows the I<sup>2</sup>C master device to address the slave only once and then send data to multiple registers in a random order. Registers can be written continuously until the master issues a STOP condition.

The Multiple Byte Register Data Pair protocol is as follows:

1. The master sends a START command.
2. The master sends the 7-bit slave address followed by a write bit.
3. The addressed slave asserts an ACKNOWLEDGE (A) by pulling SDA low.
4. The master sends an 8-bit register pointer.
5. The slave acknowledges the register pointer.
6. The master sends a data byte.
7. The slave acknowledges the data byte. At the rising edge of SCL, the data byte is loaded into its target register and the data becomes active.
8. Steps 4 to 7 are repeated as many times as the master requires.
9. The master sends a STOP condition. During the rising edge of the stop related SDA edge, the data byte that was previously written is loaded into the target register and becomes active.

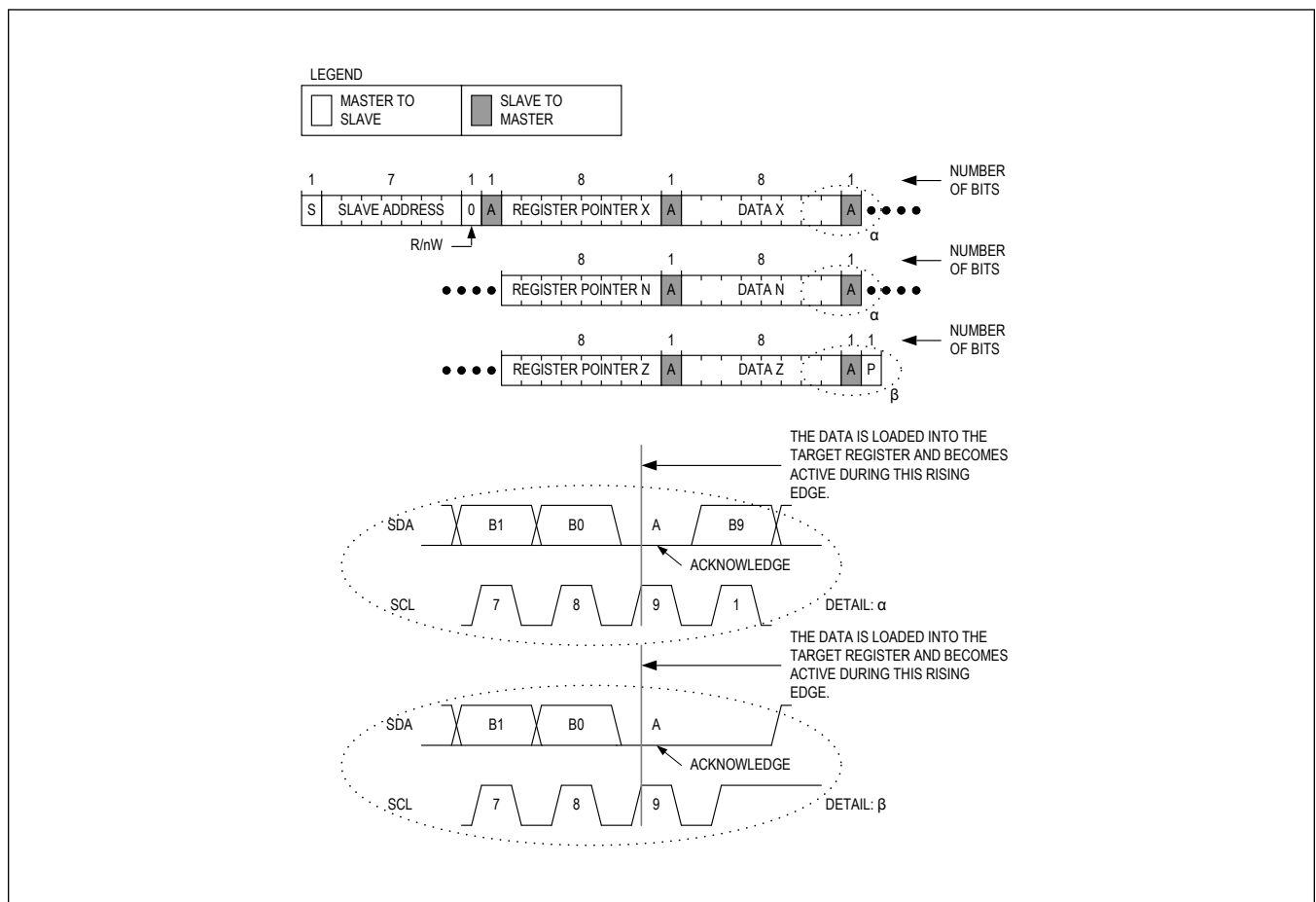

Figure 11. Writing to Multiple Registers with “Multiple Byte Register-Data Pairs” Protocol

**Reading from a Single Register**

The I<sup>2</sup>C master device reads one byte of data to the devices. This protocol is the same as SMBus specification’s Read Byte protocol.

The Read Byte protocol is as follows:

1. The master sends a START command (S).
2. The master sends the 7-bit slave address followed by a write bit ( $R/\overline{W} = 0$ ).
3. The addressed slave asserts an ACKNOWLEDGE (A) by pulling SDA low.
4. The master sends an 8-bit register pointer.
5. The slave acknowledges the register pointer.
6. The master sends a REPEATED START command (Sr).
7. The master sends the 7-bit slave address followed by a read bit ( $R/\overline{W} = 1$ ).
8. The addressed slave asserts an ACKNOWLEDGE (A) by pulling SDA low.
9. The addressed slave places 8 bits of data on the bus from the location specified by the register pointer.
10. The master issues a NOT-ACKNOWLEDGE (nA).
11. The master sends a STOP condition (P) or a REPEATED START condition (Sr). Issuing a P ensures that the bus input filters are set for 1MHz or slower operation. Issuing a REPEATED START (Sr) leaves the bus input filters in their current state.

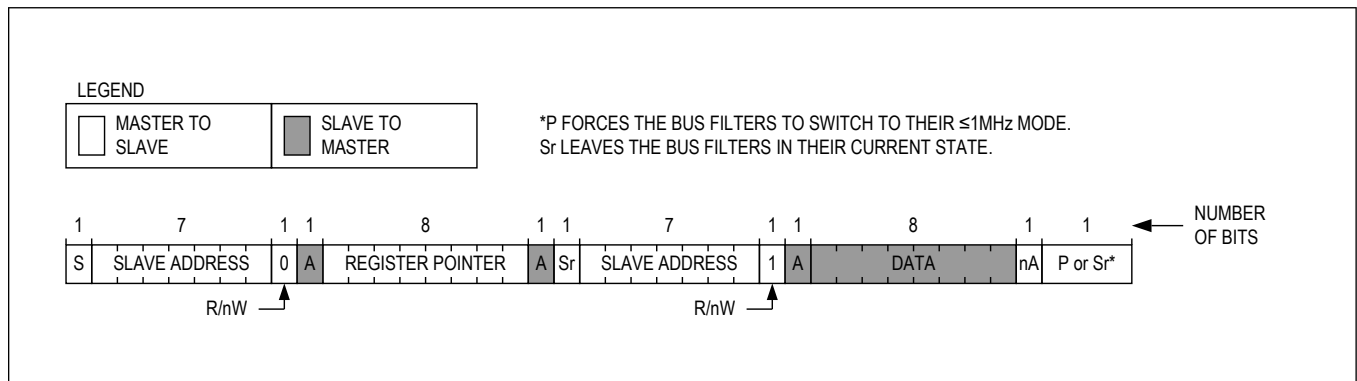

Figure 12. Reading from a Single Register

**Reading from Sequential Registers**

Figure 13 shows the protocol for reading from sequential registers. This protocol is similar to the Read Byte protocol except the master issues an ACKNOWLEDGE (A) to signal the slave that it wants more data—when the master has all the data it requires, it issues a not-acknowledge (nA) and a STOP (P) to end the transmission.

The Continuous Read from Sequential Registers protocol is as follows:

1. The master sends a START command (S).
2. The master sends the 7-bit slave address followed by a write bit ( $R/\overline{W} = 0$ ).
3. The addressed slave asserts an ACKNOWLEDGE (A) by pulling SDA low.
4. The master sends an 8-bit register pointer.
5. The slave acknowledges the register pointer.
6. The master sends a REPEATED START command (Sr).
7. The master sends the 7-bit slave address followed by a read bit ( $R/\overline{W} = 1$ ).
8. The addressed slave asserts an ACKNOWLEDGE (A) by pulling SDA low.
9. The addressed slave places 8 bits of data on the bus from the location specified by the register pointer.
10. The master issues an ACKNOWLEDGE (A) signaling the slave that it wishes to receive more data.
11. Steps 9 to 10 are repeated as many times as the master requires. Following the last byte of data, the master must issue a NOT-ACKNOWLEDGE (nA) to signal that it wishes to stop receiving data.
12. The master sends a STOP condition (P) or a REPEATED START condition (Sr). Issuing a STOP (P) ensures that the bus input filters are set for 1MHz or slower operation. Issuing a REPEATED START (Sr) leaves the bus input filters in their current state.

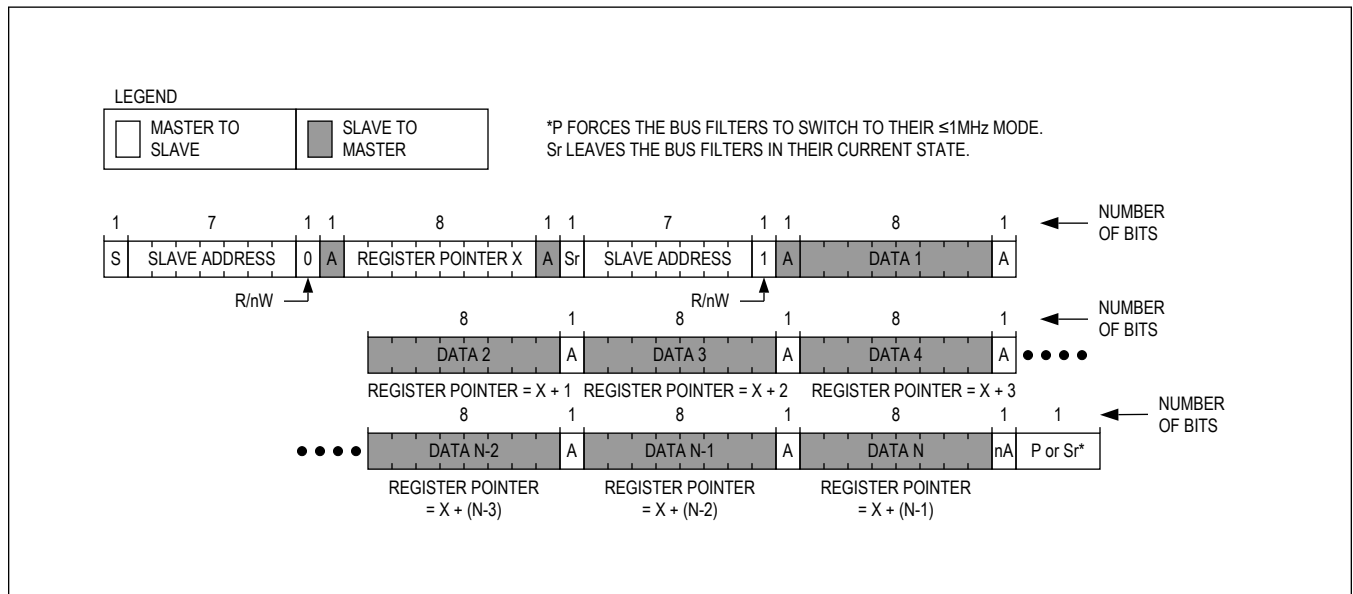

Figure 13. Reading from Sequential Registers

## Register Map

## FUNC

ADDRESS	NAME	MSB							LSB
<b>TOP</b>									
0x00	<a href="#">CID[7:0]</a>	REVISION[2:0]			VERSION[4:0]				
0x01	<a href="#">SWRST[7:0]</a>	SW_RST[7:0]							
0x02	<a href="#">TOP_INT[7:0]</a>	SPR[4:0]				TSHDN_I	SYSOVL_O_I	SYSUVL_O_I	
0x03	<a href="#">TOP_INT_MASK[7:0]</a>	SPR[4:0]				TSHDN_M	SYSOVL_O_M	SYSUVL_O_M	
0x04	<a href="#">TOP_INT_OK[7:0]</a>	SPR[4:0]				TSHDN_OK	SYSOVL_O_OK	SYSUVL_O_OK	
<b>CHARGER_FUNC</b>									
0x10	<a href="#">CHG_INT[7:0]</a>	AICL_I	CHGIN_I	B2SOVR_C_I	CHG_I	BAT_I	CHGINIL_IM_I	DISQBA_T_I	OTG_PL_IM_I
0x11	<a href="#">CHG_INT_MASK[7:0]</a>	AICL_M	CHGIN_M	B2SOVR_C_M	CHG_M	BAT_M	CHGINIL_IM_M	DISQBA_T_M	OTG_PL_IM_M
0x12	<a href="#">CHG_INT_OK[7:0]</a>	AICL_OK	CHGIN_OK	B2SOVR_C_OK	CHG_OK	BAT_OK	CHGINIL_IM_OK	DISQBA_T_OK	OTG_PL_IM_OK
0x13	<a href="#">CHG_DETAILS_00[7:0]</a>	SPR7	CHGIN_DTLS[1:0]	OTG_DTLS[1:0]		SPR2_1[1:0]		QB_DTLS	
0x14	<a href="#">CHG_DETAILS_01[7:0]</a>	TREG	BAT_DTLS[2:0]			CHG_DTLS[3:0]			
0x15	<a href="#">CHG_DETAILS_02[7:0]</a>	SPR	THM_DTLS[2:0]			APP_MODE_DTLS	FSW_DTLS[1:0]		NUM_CELLS
0x16	<a href="#">CHG_CNFG_00[7:0]</a>	COMM_MODE	DISIBS	STBY_EN	WDTEN	MODE[3:0]			
0x17	<a href="#">CHG_CNFG_01[7:0]</a>	PQEN	LPM	CHG_RSTRT[1:0]		STAT_EN	FCHGTIME[2:0]		
0x18	<a href="#">CHG_CNFG_02[7:0]</a>	SPR[1:0]		CHGCC[5:0]					
0x19	<a href="#">CHG_CNFG_03[7:0]</a>	SYS_TRACK_DS	B2SOVR_C_DTC	TO_TIME[2:0]			TO_ITH[2:0]		
0x1A	<a href="#">CHG_CNFG_04[7:0]</a>	SPR[1:0]		CHG_CV_PRM[5:0]					
0x1B	<a href="#">CHG_CNFG_05[7:0]</a>	RESERVED[1:0]		ITRICKLE[1:0]		B2SOVRC[3:0]			
0x1C	<a href="#">CHG_CNFG_06[7:0]</a>	SPR7	RESERVED[1:0]		SPR4	CHGPROT[1:0]		WDTCLR[1:0]	
0x1D	<a href="#">CHG_CNFG_07[7:0]</a>	JEITA_EN	REGTEMP[3:0]			VCHGC_V_COOL	ICHGCC_COOL	FSHIP_MODE	
0x1E	<a href="#">CHG_CNFG_08[7:0]</a>	RESERVED	CHGIN_ILIM[6:0]						
0x1F	<a href="#">CHG_CNFG_09[7:0]</a>	INLIM_CLK[1:0]		OTG_ILIM[2:0]			MINVSYS[2:0]		
0x20	<a href="#">CHG_CNFG_10[7:0]</a>	SPR[1:0]		VCHGIN_REG[4:0]					DISKIP

## Register Details

[CID \(0x0\)](#)

BIT	7	6	5	4	3	2	1	0
Field	REVISION[2:0]				VERSION[4:0]			
Reset	0x5				0x0			
Access Type	Read Only				Read Only			

BITFIELD	BITS	DESCRIPTION	DECODE
REVISION	7:5	Silicon Revision	
VERSION	4:0	OTP Recipe Version	

[SWRST \(0x1\)](#)

BIT	7	6	5	4	3	2	1	0
Field	SW_RST[7:0]							
Reset	0x00							
Access Type	Write, Read							

BITFIELD	BITS	DESCRIPTION	DECODE
SW_RST	7:0	Software Reset	0xA5: O-type registers are reset. SW_RST register is autoclear as under O-type reset control. All others: No reset

[TOP\\_INT \(0x2\)](#)

BIT	7	6	5	4	3	2	1	0
Field	SPR[4:0]					TSHDN_I	SYSOVLO_I	SYSUVLO_I
Reset	0x0					0x0	0x0	0x0
Access Type	Read Clears All					Read Clears All	Read Clears All	Read Clears All

BITFIELD	BITS	DESCRIPTION	DECODE
SPR	7:3	Spare Bit	
TSHDN_I	2	Thermal Shutdown Interrupt	0b0: No interrupt detected 0b1: Interrupt detected
SYSOVLO_I	1	SYSOVLO Interrupt	0b0: No interrupt detected 0b1: Interrupt detected
SYSUVLO_I	0	SYSUVLO Interrupt	0b0: No interrupt detected 0b1: Interrupt detected

**TOP\_INT\_MASK (0x3)**

BIT	7	6	5	4	3	2	1	0
Field	SPR[4:0]					TSHDN_M	YSOVLO_M	YSUVLO_M
Reset	0x1F					0x1	0x1	0x1
Access Type	Write, Read					Write, Read	Write, Read	Write, Read

BITFIELD	BITS	DESCRIPTION	DECODE
SPR	7:3	Spare Bit	
TSHDN_M	2	Thermal Shutdown Interrupt Mask	0b0: Unmasked 0b1: Masked
YSOVLO_M	1	YSOVLO Interrupt Mask	0b0: Unmasked 0b1: Masked
YSUVLO_M	0	YSUVLO Interrupt Mask	0b0: Unmasked 0b1: Masked

**TOP\_INT\_OK (0x4)**

BIT	7	6	5	4	3	2	1	0
Field	SPR[4:0]					TSHDN_OK	YSOVLO_OK	YSUVLO_OK
Reset	0x0					0x1	0x1	0x1
Access Type	Read Only					Read Only	Read Only	Read Only

BITFIELD	BITS	DESCRIPTION	DECODE
SPR	7:3	Spare Bit	
TSHDN_OK	2	Thermal shutdown Status Indicator	0b0: Device is in thermal shutdown 0b1: Device is not in thermal shutdown
YSOVLO_OK	1	YSOVLO Status Indicator	0b0: SYS voltage is above YSOVLO threshold 0b1: SYS voltage is below YSOVLO threshold
YSUVLO_OK	0	YSUVLO Status Indicator	0b0: SYS voltage is below YSUVLO threshold 0b1: SYS voltage is above YSUVLO threshold

**CHG\_INT (0x10)**

Interrupt status register for the charger block.

BIT	7	6	5	4	3	2	1	0
Field	AICL_I	CHGIN_I	B2SOVRC_I	CHG_I	BAT_I	CHGINILIM_I	DISQBAT_I	OTG_PLIM_I
Reset	0x0	0x0	0x0	0x0	0x0	0x0	0x0	0x0
Access Type	Read Clears All	Read Clears All	Read Clears All	Read Clears All	Read Clears All	Read Clears All	Read Clears All	Read Clears All

BITFIELD	BITS	DESCRIPTION	DECODE
AICL_I	7	AICL Interrupt	0b0: The AICL_OK bit has not changed since the last time this bit was read. 0b1: The AICL_OK bit has changed since the last time this bit was read.

BITFIELD	BITS	DESCRIPTION	DECODE
CHGIN_I	6	CHGIN Interrupt	0b0: The CHGIN_OK bit has not changed since the last time this bit was read. 0b1: The CHGIN_OK bit has changed since the last time this bit was read.
B2SOVRC_I	5	B2SOVRC Interrupt	0b0: The B2SOVRC_OK bit has not changed since the last time this bit was read. 0b1: The B2SOVRC_OK bit has changed since the last time this bit was read.
CHG_I	4	Charger Interrupt	0b0: The CHG_OK bit has not changed since the last time this bit was read. 0b1: The CHG_OK bit has changed since the last time this bit was read.
BAT_I	3	Battery Interrupt	0b0: The BAT_OK bit has not changed since the last time this bit was read. 0b1: The BAT_OK bit has changed since the last time this bit was read.
CHGINILIM_I	2	CHGINILIM Interrupt	0b0: The CHGINILIM_OK bit has not changed since the last time this bit was read. 0b1: The CHGINILIM_OK bit has changed since the last time this bit was read.
DISQBAT_I	1	DISQBAT Interrupt	0b0: The DISQBAT_OK bit has not changed since the last time this bit was read. 0b1: The DISQBAT_OK bit has changed since the last time this bit was read.
OTG_PLIM_I	0	OTG Interrupt/PLIM Interrupt	0b0: Mode = 0xA: The OTG_OK bit has not changed since the last time this bit was read. Mode ≠ 0xA: PLIM_OK bit has not changed since the last time this bit was read. 0b1: Mode = 0xA: The OTG_OK bit has changed since the last time this bit was read. Mode ≠ 0xA: The PLIM_OK bit has changed since the last time this bit was read.

**CHG\_INT\_MASK (0x11)**

Mask register to mask the corresponding charger interrupts.

BIT	7	6	5	4	3	2	1	0
Field	AICL_M	CHGIN_M	B2SOVRC_M	CHG_M	BAT_M	CHGINILIM_M	DISQBAT_M	OTG_PLIM_M
Reset	0x1	0x1	0x1	0x1	0x1	0x1	0x1	0x1
Access Type	Write, Read	Write, Read	Write, Read	Write, Read	Write, Read	Write, Read	Write, Read	Write, Read

BITFIELD	BITS	DESCRIPTION	DECODE
AICL_M	7	AICL Interrupt Mask	0b0: Unmasked 0b1: Masked
CHGIN_M	6	CHGIN Interrupt Mask	0b0: Unmasked 0b1: Masked
B2SOVRC_M	5	B2SOVRC Interrupt Mask	0b0: Unmasked 0b1: Masked
CHG_M	4	Charger Interrupt Mask	0b0: Unmasked 0b1: Masked

BITFIELD	BITS	DESCRIPTION	DECODE
BAT_M	3	Battery Interrupt Mask	0b0: Unmasked 0b1: Masked
CHGINILIM_M	2	CHGINILIM Interrupt Mask	0b0: Unmasked 0b1: Masked
DISQBAT_M	1	DISQBAT Interrupt Mask	0b0: Unmasked 0b1: Masked
OTG_PLIM_M	0	OTG/PLIM Interrupt Mask	0b0: Unmasked 0b1: Masked

**CHG\_INT\_OK (0x12)**

BIT	7	6	5	4	3	2	1	0
Field	AICL_OK	CHGIN_OK	B2SOVRC_OK	CHG_OK	BAT_OK	CHGINILIM_OK	DISQBAT_OK	OTG_PLIM_OK
Reset	0x1	0x0	0x1	0x1	0x1	0x1	0x1	0x1
Access Type	Read Only	Read Only	Read Only	Read Only	Read Only	Read Only	Read Only	Read Only

BITFIELD	BITS	DESCRIPTION	DECODE
AICL_OK	7	AICL_OK Status	0b0: AICL mode 0b1: Not in AICL mode
CHGIN_OK	6	CHGIN Input Status Indicator. See CHGIN_DTLS for more information.	0b0: The CHGIN input is invalid. CHGIN_DTLS ≠ 0x03. 0b1: The CHGIN input is valid. CHGIN_DTLS = 0x03.
B2SOVRC_OK	5	B2SOVRC Status	0b0: BATT to SYS exceeds current limit. 0b1: BATT to SYS does not exceed current limit.
CHG_OK	4	Charger Status Indicator. See CHG_DTLS for more information.	0b0: The charger has reduced charge current or charge termination voltage based on JEITA control, suspended charging, or TREG = 1. 0b1: The charger is OK or the charger is off.
BAT_OK	3	Battery Status Indicator. See BAT_DTLS for more information.	0b0: The battery has an issue or the charger has been suspended. BAT_DTLS ≠ 0x03 and ≠ 0x07. 0b1: The battery is OK. BAT_DTLS = 0x03 or BAT_DTLS = 0x07.
CHGINILIM_OK	2	CHGINILIM Status	0b0: The CHGIN input has reached the current limit. 0b1: The CHGIN input has not reached the current limit.
DISQBAT_OK	1	DISQBAT Status	0b0: DISQBAT pin is high or DISIBS bit is set to 1 and Q <sub>BAT</sub> disabled. 0b1: DISQBAT is low and DISIBS bit is 0 and Q <sub>BAT</sub> not disabled.
OTG_PLIM_OK	0	Mode = 0xA: OTG Status Indicator. See OTG_DTLS for more information. Mode ≠ 0xA: PLIM status indicator (buck-boost limit reached).	0b0: Mode = 0xA: There is a fault in OTG mode. OTG_DTLS ≠ 0x11. Mode ≠ 0xA: Buck-boost reaches positive current limit. 0b1: Mode = 0xA: The OTG operation is OK. OTG_DTLS = 0x11. Mode ≠ 0xA: Buck-boost does not reach positive current limit.

[CHG\\_DETAILS\\_00 \(0x13\)](#)

BIT	7	6	5	4	3	2	1	0
Field	SPR7	CHGIN_DTLS[1:0]		OTG_DTLS[1:0]		SPR2_1[1:0]		QB_DTLS
Reset	0x0	0x0		0x0		0x0		0x0
Access Type	Read Only	Read Only		Read Only		Read Only		Read Only

BITFIELD	BITS	DESCRIPTION	DECODE
SPR7	7	Spare Bit	
CHGIN_DTLS	6:5	CHGIN Details	0b00: V <sub>BUS</sub> is invalid. V <sub>CHGIN</sub> < V <sub>CHGIN_UVLO</sub> 0b01: RSVD 0b10: V <sub>BUS</sub> is invalid. V <sub>CHGIN</sub> > V <sub>CHGIN_OVLO</sub> 0b11: V <sub>BUS</sub> is valid. V <sub>CHGIN</sub> > V <sub>CHGIN_UVLO</sub> and V <sub>CHGIN</sub> < V <sub>CHGIN_OVLO</sub>
OTG_DTLS	4:3	OTG Details	0b00: OTG output (V <sub>CHGIN</sub> ) is in undervoltage condition. V <sub>CHGIN</sub> < V <sub>OTG_UVLO</sub> 0b01: OTG output (V <sub>CHGIN</sub> ) is in current limit (OTG_ILIM) within the last 37.5ms. 0b10: OTG output (V <sub>CHGIN</sub> ) is in overvoltage condition. V <sub>CHGIN</sub> > V <sub>OTG_OVLO</sub> 0b11: OTG is disabled (OTGEN = low and MODE ≠ 0xA) or OTG output (V <sub>CHGIN</sub> ) is valid. V <sub>CHGIN</sub> > V <sub>OTG_UVLO</sub> and V <sub>CHGIN</sub> < V <sub>OTG_OVLO</sub> and it's not in current limit.
SPR2_1	2:1	Spare Bit	
QB_DTLS	0	Q <sub>BAT</sub> status Read back value of QB_DTLS reflects the actual Q <sub>BAT</sub> state.	0b0: Q <sub>BAT</sub> is off. 0b1: Q <sub>BAT</sub> is on.

[CHG\\_DETAILS\\_01 \(0x14\)](#)

BIT	7	6	5	4	3	2	1	0
Field	TREG	BAT_DTLS[2:0]			CHG_DTLS[3:0]			
Reset	0x0	0x7			0x8			
Access Type	Read Only	Read Only			Read Only			

BITFIELD	BITS	DESCRIPTION	DECODE
TREG	7	Temperature Regulation Status	0b0: The junction temperature is less than the threshold set by REGTEMP and the full charge current limit is available. 0b1: The junction temperature is greater than the threshold set by REGTEMP and the charge current limit can be folding back to reduce power dissipation.

BITFIELD	BITS	DESCRIPTION	DECODE
BAT_DTLS	6:4	<p>Battery Details                      Note: Only B2SOVRC is reported in Battery Only mode. As a consequence, BAT_OK = 1 is also reported in BAT_DTLS = 0x07.</p> <p>In the event that multiple faults occur within the battery details category, overcurrent has priority followed by no battery, then overvoltage, then timer fault, then below prequal.</p>	<p>0b000: Battery removal is detected on THM pin.                      0b001: V<sub>BATT</sub> &lt; V<sub>PRECHG</sub>. This condition is also reported in the CHG_DTLS as 0x00.                      0b010: The battery is taking longer than expected to charge. This could be due to high system currents, an old battery, a damaged battery or something else. Charging has suspended and the charger is in its timer fault mode. This condition is also reported in the CHG_DTLS as 0x06.                      0b011: The battery is OK and its voltage is greater than the minimum system voltage (V<sub>SYSTEMIN</sub> - 500mV &lt; V<sub>BATT</sub>). Q<sub>BAT</sub> is on and V<sub>SYS</sub> is approximately equal to V<sub>BATT</sub>.                      0b100: The battery is okay but its voltage is low: V<sub>PRECHG</sub> &lt; V<sub>BATT</sub> &lt; V<sub>SYSTEMIN</sub> - 500mV. This condition is also reported in the CHG_DTLS as 0x00.                      0b101: The battery voltage has been greater than the battery overvoltage threshold (CHG_CV_PRM + 240mV/cell) for the last 30ms. This flag is only generated when there is a valid input.                      0b110: The battery has been overcurrent for at least 3ms since the last time this register has been read.                      0b111: Battery level not available. In battery only mode, all battery comparators are off except for B2SOVRC.</p>

BITFIELD	BITS	DESCRIPTION	DECODE
CHG_DTLS	3:0	Charger Details	<p>0x00: Charger is in precharge or trickle charge mode            CHG_OK = 1 and V<sub>BATT</sub> &lt; V<sub>SYSTEMIN</sub> - 500mV and T<sub>J</sub> &lt; T<sub>SHDN</sub></p> <p>0x01: Charger is in fast-charge constant current mode            CHG_OK = 1 and V<sub>BATT</sub> &lt; V<sub>BATTREG</sub> and T<sub>J</sub> &lt; T<sub>SHDN</sub></p> <p>0x02: Charger is in fast-charge constant voltage mode            CHG_OK = 1 and V<sub>BATT</sub> = V<sub>BATTREG</sub> and T<sub>J</sub> &lt; T<sub>SHDN</sub></p> <p>0x03: Charger is in top-off mode            CHG_OK = 1 and V<sub>BATT</sub> = V<sub>BATTREG</sub> and T<sub>J</sub> &lt; T<sub>SHDN</sub></p> <p>0x04: Charger is in done mode            CHG_OK = 0 and V<sub>BATT</sub> &gt; V<sub>BATTREG</sub> - V<sub>RSTRT</sub> and T<sub>J</sub> &lt; T<sub>SHDN</sub></p> <p>0x05: Charger is off because at least one pin of INLIM, ITO, ISET, or VSET has valid resistance while others don't (invalid resistance, open or tied to PVL). Configure charger with I<sup>2</sup>C, then set COMM_MODE to 1 enables charging.            CHG_OK = 0</p> <p>0x06: Charger is in timer fault mode            CHG_OK = 0 and if BAT_DTLS = 0b001 then V<sub>BATT</sub> &lt; V<sub>SYSTEMIN</sub> - 500mV or V<sub>BATT</sub> &lt; V<sub>PRECHG</sub> and T<sub>J</sub> &lt; T<sub>SHDN</sub></p> <p>0x07: Charger is suspended because Q<sub>BAT</sub> is disabled (DISQBAT = high or DISIBS = 1)            CHG_OK = 0</p> <p>0x08: Charger is off, charger input invalid and/or charger is disabled            CHG_OK = 1</p> <p>0x09: Reserved</p> <p>0x0A: Charger is off and the junction temperature is &gt; T<sub>SHDN</sub>            CHG_OK = 0</p> <p>0x0B: Charger is off because the watchdog timer expired            CHG_OK = 0</p> <p>0x0C: Charger is suspended or charge current or voltage is reduced based on JEITA control. This condition is also reported in THM_DTLS.            CHG_OK = 0</p> <p>0x0D: Charger is suspended because battery removal is detected on THM pin. This condition is also reported in THM_DTLS.            CHG_OK = 0</p> <p>0x0E: Reserved</p> <p>0x0F: Reserved</p>

[CHG\\_DETAILS\\_02 \(0x15\)](#)

BIT	7	6	5	4	3	2	1	0
Field	SPR	THM_DTLS[2:0]			APP_MODE_DTLS	FSW_DTLS[1:0]		NUM_CELL_DTLS
Reset	0x0	0x2			0x0	0x0		0x0
Access Type	Read Only	Read Only			Read Only	Read Only		Read Only

BITFIELD	BITS	DESCRIPTION	DECODE
SPR	7	Spare bit	
THM_DTLS	6:4	Thermistor Status. This is also reported in the CHG_DTLS as 0x0C.	0b000: Low temperature and charging suspended (COLD) 0b001: Low temperature charging (cool) 0b010: Normal temperature charging (normal) 0b011: High temperature charging (warm) 0b100: High temperature and charging suspended (hot) 0b101: Battery removal detected on THM pin 0b110: Thermistor monitoring is disabled 0b111: Reserved
APP_MODE_DTLS	3	Application Mode Status	0b0: Device is configured to operate as a standalone DC-DC converter. 0b1: Device is configured to operate as a charger.
FSW_DTLS	2:1	Programmed Switching Frequency Details	0x0: 600kHz 0x1: Reserved 0x2: Reserved 0x3: Reserved
NUM_CELL_DTLS	0	Number of Serially Connected Battery Cells Details	0b0: Device is configured to support a 2-cell battery. 0b1: Device is configured to support a 3-cell battery.

[CHG\\_CNFG\\_00 \(0x16\)](#)

## Charger configuration 0

BIT	7	6	5	4	3	2	1	0
Field	COMM_MODE	DISIBS	STBY_EN	WDTEN	MODE[3:0]			
Reset	0x0	0x0	0x0	0x0	0x5			
Access Type	Write, Read	Write, Read	Write, Read	Write, Read	Write, Read			

BITFIELD	BITS	DESCRIPTION	DECODE
COMM_MODE	7	I <sup>2</sup> C Mode Enable	<p>0b0: Autonomous Mode CHGIN_ILIM, CHGCC, CHG_CV_PRM, and TO_ITH registers are programmed by external resistors on INLIM, ISET, VSET and ITO pins.</p> <p>Writing 0 to COMM_MODE is ignored.</p> <p>0b1: I<sup>2</sup>C Mode Enabled CHGIN_ILIM, CHGCC, CHG_CV_PRM and TO_ITH registers are programmed by I<sup>2</sup>C.</p> <p>Writing 1 to COMM_MODE is allowed. Writing COMM_MODE=1 clears any charger suspension due to invalid resistance detected on INLIM, ISET, VSET, and ITO pins. Charger starts with I<sup>2</sup>C programmed settings in CHGIN_ILIM, CHGCC, CHG_CV_PRM, and TO_ITH registers.</p>
DISIBS	6	BATT to SYS FET Disable Control Read back value of DISIBS register bit reflects the actual DISIBS command or DISQBAT PIN state.	<p>0b0: BATT to SYS FET is controlled by the power path state machine.</p> <p>0b1: BATT to SYS FET is forced off.</p>
STBY_EN	5	CHGIN Standby Enable Read back value of the STBY_EN register bit reflects the actual CHGIN standby setting.	<p>0b0: DC-DC is controlled by the power path state machine.</p> <p>0b1: Force DC-DC off. Device goes to CHGIN low quiescent current standby.</p>
WDTEN	4	<p>Watchdog Timer Enable.</p> <p>While enabled, the system controller must reset the watchdog timer within the timer period (<math>t_{WD}</math>) for the charger to operate normally. Reset the watchdog timer by programming WDTCLR = 0x01.</p>	<p>0b0: Watchdog timer disabled</p> <p>0b1: Watchdog timer enabled</p>

BITFIELD	BITS	DESCRIPTION	DECODE
MODE	3:0	Smart Power Selector Configuration. Read back value of the MODE register reflects the actual smart power selector configuration.	0x0: Charger = off, OTG = off, DC-DC = off. When the Q <sub>BAT</sub> switch is on (DISQBAT = low and DISIBS = 0), the battery powers the system. 0x1: Same as 0b0000 0x2: Same as 0b0000 0x3: Same as 0b0000 0x4: Charger = off, OTG = off, DC-DC = on. When there is a valid input, the DC-DC converter regulates the system voltage to be the maximum of (V <sub>SYSTEMIN</sub> and V <sub>BATT</sub> + 4%). 0x5: Charger = on, OTG = off, DC-DC = on. When there is a valid input, the battery is charging. V <sub>SYST</sub> is the larger of V <sub>SYSTEMIN</sub> and $\sim V_{BATT} + I_{BAT} \times R_{BAT2SYS}$ . 0x6: Same as 0b0101 0x7: Same as 0b0101 0x8: RSVD 0x9: RSVD 0xA: Charger = off, OTG = on, DC-DC = off. The Q <sub>BAT</sub> switch is on to allow the battery to support the system, the charger's DC-DC operates in reverse mode as a buck converter. The OTG output, CHGIN, can source current up to I <sub>CHGIN.OTG.LIM</sub> . The CHGIN target voltage is V <sub>CHGIN.OTG</sub> . 0xB: RSVD 0xC: RSVD 0xD: RSVD 0xE: RSVD 0xF: RSVD

**CHG\_CNFG\_01 (0x17)**

## Charger configuration 1

BIT	7	6	5	4	3	2	1	0
Field	PQEN	LPM	CHG_RSTRT[1:0]		STAT_EN	FCHGTIME[2:0]		
Reset	0x1	0x0	0x1		0x1	0x1		
Access Type	Write, Read	Write, Read	Write, Read		Write, Read	Write, Read		

BITFIELD	BITS	DESCRIPTION	DECODE
PQEN	7	Low-Battery Prequalification Mode Enable	0b0: Low-Battery Prequalification mode is disabled. 0b1: Low-Battery Prequalification mode is enabled.
LPM	6	Low Power Mode control	0b0: Q <sub>BAT</sub> charge pump runs in Normal mode. 0b1: Q <sub>BAT</sub> charge pump is in Low Power Mode.
CHG_RSTRT	5:4	Charger Restart Threshold	0b00: 100mV/cell below the value programmed by CHG_CV_PRM 0b01: 150mV/cell below the value programmed by CHG_CV_PRM 10: 200mV/cell below the value programmed by CHG_CV_PRM 11: Disabled
STAT_EN	3	Charge Indicator Output Enable	0b0: Disable STAT output 0b1: Enable STAT output

BITFIELD	BITS	DESCRIPTION	DECODE
FCHGTIME	2:0	Fast-Charge Timer setting (t <sub>FC</sub> , hrs)	0b000: Disable 0b001: 3 0b010: 4 0b011: 5 0b100: 6 0b101: 7 0b110: 8 0b111: 10

**CHG\_CNFG\_02 (0x18)**

Charger configuration 2

BIT	7	6	5	4	3	2	1	0
Field	SPR[1:0]		CHGCC[5:0]					
Reset	0x0		0x7					
Access Type	Write, Read		Write, Read					

BITFIELD	BITS	DESCRIPTION	DECODE
SPR	7:6	Spare Bit	

BITFIELD	BITS	DESCRIPTION	DECODE
CHGCC	5:0	<p>Fast-Charge Current Selection (mA). When the charger is enabled, the charge current limit is set by these bits.</p> <p>Read back value of the CHGCC register reflects the actual fast charge current programmed in the charger.</p> <p>The thermal foldback loop can reduce the battery charger's target current by A<sub>TJREG</sub>.</p>	<p>0x00: 100 0x01: 150 0x02: 200 0x03: 250 0x04: 300 0x05: 350 0x06: 400 0x07: 450 0x08: 500 0x09: 600 0x0A: 700 0x0B: 800 0x0C: 900 0x0D: 1000 0x0E: 1100 0x0F: 1200 0x10: 1300 0x11: 1400 0x12: 1500 0x13: 1600 0x14: 1700 0x15: 1800 0x16: 1900 0x17: 2000 0x18: 2100 0x19: 2200 0x1A: 2300 0x1B: 2400 0x1C: 2500 0x1D: 2600 0x1E: 2700 0x1F: 2800 0x20: 2900 0x21: 3000 0x22: 3100 0x23: 3200 0x24: 3300 0x25: 3400 0x26: 3500 0x27: 3600 0x28: 3700 0x29: 3800 0x2A: 3900 0x2B: 4000 0x2C: 4100 0x2D: 4200 0x2E: 4300 0x2F: 4400 0x30: 4500 0x31: 4600 0x32: 4700 0x33: 4800 0x34: 4900 0x35: 5000 0x36: 5100 0x37: 5200 0x38: 5300 0x39: 5400 0x3A: 5500</p>

BITFIELD	BITS	DESCRIPTION	DECODE
			0x3B: 5600 0x3C: 5700 0x3D: 5800 0x3E: 5900 0x3F: 6000

**CHG\_CNFG\_03 (0x19)**

## Charger configuration 3

BIT	7	6	5	4	3	2	1	0
<b>Field</b>	SYS_TRAC K_DIS	B2SOVRC_ DTC	TO_TIME[2:0]			TO_ITH[2:0]		
<b>Reset</b>	0x1	0x0	0x3			0x0		
<b>Access Type</b>	Write, Read	Write, Read	Write, Read			Write, Read		

BITFIELD	BITS	DESCRIPTION	DECODE
SYS_TRACK _DIS	7	SYS Tracking Disable Control	0x0: SYS tracking is enabled. SYS is regulated to MAX of (V <sub>BATT</sub> + 4%, V <sub>SYSTEMIN</sub> ). This is also valid in Charge Done state. 0x1: SYS tracking is disabled. SYS is regulated to V <sub>CHG_CV_PRM</sub> .
B2SOVRC_D TC	6	Battery to SYS Overcurrent Debounce Time Control. While under OVRC condition, after t <sub>OCP</sub> switcher (and therefore charge) is disabled.	0x0: t <sub>OCP</sub> = 6ms 0x1: t <sub>OCP</sub> = 100ms
TO_TIME	5:3	Top-Off Timer Setting (min)	0b000: 30s 0b001: 10 0b010: 20 0b011: 30 0b100: 40 0b101: 50 0b110: 60 0b111: 70
TO_ITH	2:0	Top-Off Current Threshold (mA). The charger transitions from its fast-charge constant voltage mode to its top-off mode when the charger current decays to the value programmed by this register. This transition generates a CHG_I interrupt and causes the CHG_DTLS register to report top-off mode. This transition also starts the top-off time as programmed by TO_TIME. Read back value of the TO_ITH register reflects the actual top-off current programmed in the charger.	0b000: 100 0b001: 200 0b010: 300 0b011: 400 0b100: 500 0b101: 600 0b110: 600 0b111: 600

**CHG\_CNFG\_04 (0x1A)**

## Charger configuration 4

MAX77960/MAX77961

25V<sub>IN</sub>, 3A<sub>OUT</sub> to 6A<sub>OUT</sub>, USB-C Buck-Boost  
Charger with Integrated FETs for 2S/3S Li-Ion  
Batteries

BIT	7	6	5	4	3	2	1	0
<b>Field</b>	SPR[1:0]		CHG_CV_PRM[5:0]					
<b>Reset</b>	0x0		0x00					
<b>Access Type</b>	Write, Read		Write, Read					
BITFIELD	BITS	DESCRIPTION			DECODE			
SPR	7:6	Spare Bit						

BITFIELD	BITS	DESCRIPTION	DECODE
CHG_CV_P RM	5:0	Charge Termination Voltage Setting (V). Read back value of the CHG_CV_PRM register reflects the actual charge termination voltage programmed in the charger when JEITA_EN = 0. When JEITA_EN = 1, charge termination voltage is controlled by V <sub>CHGCV_COOL</sub> and V <sub>CHGCV_WARM</sub> register settings.	2 Cell Battery 0x00: 8.000 0x01: 8.020 0x02: 8.040 0x03: 8.060 0x04: 8.080 0x05: 8.100 0x06: 8.120 0x07: 8.140 0x08: 8.160 0x09: 8.180 0x0A: 8.200 0x0B: 8.220 0x0C: 8.240 0x0D: 8.260 0x0E: 8.280 0x0F: 8.300 0x10: 8.320 0x11: 8.340 0x12: 8.360 0x13: 8.380 0x14: 8.400 0x15: 8.420 0x16: 8.440 0x17: 8.460 0x18: 8.480 0x19: 8.500 0x1A: 8.520 0x1B: 8.540 0x1C: 8.560 0x1D: 8.580 0x1E: 8.600 0x1F: 8.620 0x20: 8.640 0x21: 8.660 0x22: 8.680 0x23: 8.700 0x24: 8.720 0x25: 8.740 0x26: 8.760 0x27: 8.780 0x28: 8.800 0x29: 8.820 0x2A: 8.840 0x2B: 8.860 0x2C: 8.880 0x2D: 8.900 0x2E: 8.920 0x2F: 8.940 0x30: 8.960 0x31: 8.980 0x32: 9.000 0x33: 9.020 0x34: 9.040 0x35: 9.060 0x36: 9.080 0x37: 9.100 0x38: 9.120 0x39: 9.140

BITFIELD	BITS	DESCRIPTION	DECODE
			0x3A: 9.160 0x3B: 9.180 0x3C: 9.200 0x3D: 9.220 0x3E: 9.240 0x3F: 9.260 3 Cell Battery 0x00: 12.000 0x01: 12.030 0x02: 12.060 0x03: 12.090 0x04: 12.120 0x05: 12.150 0x06: 12.180 0x07: 12.210 0x08: 12.240 0x09: 12.270 0x0A: 12.300 0x0B: 12.330 0x0C: 12.360 0x0D: 12.390 0x0E: 12.420 0x0F: 12.450 0x10: 12.480 0x11: 12.510 0x12: 12.540 0x13: 12.570 0x14: 12.600 0x15: 12.630 0x16: 12.660 0x17: 12.690 0x18: 12.720 0x19: 12.750 0x1A: 12.780 0x1B: 12.810 0x1C: 12.840 0x1D: 12.870 0x1E: 12.900 0x1F: 12.930 0x20: 12.960 0x21: 12.990 0x22: 13.020 0x23: 13.050

**CHG\_CNFG\_05 (0x1B)**

Charger configuration 5

BIT	7	6	5	4	3	2	1	0
<b>Field</b>	RESERVED[1:0]		ITRICKLE[1:0]		B2SOVRC[3:0]			
<b>Reset</b>	0x1		0x0		0x4			
<b>Access Type</b>	Write, Read		Write, Read		Write, Read			
BITFIELD	BITS	DESCRIPTION			DECODE			
RESERVED	7:6	Reserved			Default value is 0x1. Do not change.			

BITFIELD	BITS	DESCRIPTION	DECODE
ITRICKLE	5:4	Trickle Charge Current Selection (mA)	0b00: 100 0b01: 200 0b10: 300 0b11: 400
B2SOVRC	3:0	BATT to SYS Overcurrent Threshold (A)	0x00: Disable 0x01: 3.000 0x02: 3.500 0x03: 4.000 0x04: 4.500 0x05: 5.000 0x06: 5.500 0x07: 6.000 0x08: 6.500 0x09: 7.000 0x0A: 7.500 0x0B: 8.000 0x0C: 8.500 0x0D: 9.000 0x0E: 9.500 0x0F: 10.000

**CHG\_CNFG\_06 (0x1C)**

Charger configuration 6

BIT	7	6	5	4	3	2	1	0
Field	SPR7	RESERVED[1:0]		SPR4	CHGPROT[1:0]		WDTCLR[1:0]	
Reset	0x0	0x0		0x0	0x0		0x0	
Access Type	Write, Read	Write, Read		Write, Read	Write, Read		Write, Read	

BITFIELD	BITS	DESCRIPTION	DECODE
SPR7	7	Spare bit	
RESERVED	6:5	Reserved	Default value is 0x0. Do not change.
SPR4	4	Spare bit	
CHGPROT	3:2	Charger Settings Protection Bit. Writing 11 to these bits unlocks the write capability for the registers that are Protected with CHGPROT. Writing any value besides 11 locks the protected registers.	0b00: Write capability locked 0b01: Write capability locked 0b10: Write capability locked 0b11: Write capability unlocked
WDTCLR	1:0	Watchdog Timer Clear Bit. Writing 01 to these bits clears the watchdog timer when the watchdog timer is enabled.	0b00: the watchdog timer is not cleared 0b01: the watchdog timer is cleared 0b10: the watchdog timer is not cleared 0b11: the watchdog timer is not cleared

**CHG\_CNFG\_07 (0x1D)**

Charger configuration 7

BIT	7	6	5	4	3	2	1	0	
Field	JEITA_EN	REGTEMP[3:0]				VCHGCV_COOL	ICHGCC_COOL	FSHIP_MODE	
Reset	0x0	0x6				0x0	0x1	0x0	
Access Type	Write, Read	Write, Read				Write, Read	Write, Read	Write, Read	

BITFIELD	BITS	DESCRIPTION	DECODE
JEITA_EN	7	JEITA Enable	0b0: JEITA disabled. Fast-charge current and charge termination voltage do not change based on thermistor temperature. 0b1: JEITA enabled. Fast-charge current and charge termination voltage change based on thermistor temperature.
REGTEMP	6:3	Junction Temperature Thermal Regulation (°C). The charger's target current limit starts to foldback and the TREG bit is set if the junction temperature is greater than the REGTEMP setpoint.	0x0: 85 0x1: 90 0x2: 95 0x3: 100 0x4: 105 0x5: 110 0x6: 115 0x7: 120 0x8: 125 0x9: 130
VCHGCV_COOL	2	JEITA-Controlled Battery Termination Voltage When Thermistor Temperature is Between T <sub>COLD</sub> and T <sub>COOL</sub>	0b0: Battery termination voltage is set by CHG_CV_PRM. 0b1: Battery termination voltage is set by (CHG_CV_PRM - 180mV/cell).
ICHGCC_COOL	1	JEITA-Controlled Battery Fast-Charge Current When Thermistor Temperature is Between T <sub>COLD</sub> and T <sub>COOL</sub>	0b0: Battery fast-charge current is set by CHGCC 0b1: Battery fast-charge current is reduced to 50% of CHGCC
FSHIP_MODE	0	Factory Ship Mode Enable	0b0: Disable factory ship mode 0b1: Enable factory ship mode

**CHG\_CNFG\_08 (0x1E)**

## Charger configuration 8

BIT	7	6	5	4	3	2	1	0
Field	RESERVED	CHGIN_ILIM[6:0]						
Reset	0x1	0x0B						
Access Type	Write, Read	Write, Read						

BITFIELD	BITS	DESCRIPTION	DECODE
RESERVED	7	Reserved	Default value is 0x1. Do not change.

BITFIELD	BITS	DESCRIPTION	DECODE
CHGIN_ILIM	6:0	CHGIN Input Current Limit (mA). Read back value of the CHGIN_ILIM register reflect the actual input current limit programmed in the charger.	0x00: 100 0x01: 100 0x02: 100 0x03: 100 0x04: 150 0x05: 200 0x06: 250 0x07: 300 0x08: 350 0x09: 400 0x0A: 450 0x0B: 500 0x0C: 550 0x0D: 600 0x0E: 650 0x0F: 700 0x10: 750 0x11: 800 0x12: 850 0x13: 900 0x14: 950 0x15: 1000 0x16: 1050 0x17: 1100 0x18: 1150 0x19: 1200 0x1A: 1250 0x1B: 1300 0x1C: 1350 0x1D: 1400 0x1E: 1450 0x1F: 1500 0x20: 1550 0x21: 1600 0x22: 1650 0x23: 1700 0x24: 1750 0x25: 1800 0x26: 1850 0x27: 1900 0x28: 1950 0x29: 2000 0x2A: 2050 0x2B: 2100 0x2C: 2150 0x2D: 2200 0x2E: 2250 0x2F: 2300 0x30: 2350 0x31: 2400 0x32: 2450 0x33: 2500 0x34: 2550 0x35: 2600 0x36: 2650 0x37: 2700 0x38: 2750 0x39: 2800 0x3A: 2850

BITFIELD	BITS	DESCRIPTION	DECODE
			0x3B: 2900 0x3C: 2950 0x3D: 3000 0x3E: 3050 0x3F: 3100 0x40: 3150 0x41: 3200 0x42: 3250 0x43: 3300 0x44: 3350 0x45: 3400 0x46: 3450 0x47: 3500 0x48: 3550 0x49: 3600 0x4A: 3650 0x4B: 3700 0x4C: 3750 0x4D: 3800 0x4E: 3850 0x4F: 3900 0x50: 3950 0x51: 4000 0x52: 4050 0x53: 4100 0x54: 4150 0x55: 4200 0x56: 4250 0x57: 4300 0x58: 4350 0x59: 4400 0x5A: 4450 0x5B: 4500 0x5C: 4550 0x5D: 4600 0x5E: 4650 0x5F: 4700 0x60: 4750 0x61: 4800 0x62: 4850 0x63: 4900 0x64: 4950 0x65: 5000 0x66: 5050 0x67: 5100 0x68: 5150 0x69: 5200 0x6A: 5250 0x6B: 5300 0x6C: 5350 0x6D: 5400 0x6E: 5450 0x6F: 5500 0x70: 5550 0x71: 5600 0x72: 5650 0x73: 5700 0x74: 5750 0x75: 5800

BITFIELD	BITS	DESCRIPTION	DECODE
			0x76: 5850 0x77: 5900 0x78: 5950 0x79: 6000 0x7A: 6050 0x7B: 6100 0x7C: 6150 0x7D: 6200 0x7E: 6250 0x7F: 6300

**CHG\_CNFG\_09 (0x1F)**

Charger configuration 9

BIT	7	6	5	4	3	2	1	0
Field	INLIM_CLK[1:0]		OTG_ILIM[2:0]			MINVSYS[2:0]		
Reset	0x2		0x3			0x3		
Access Type	Write, Read		Write, Read			Write, Read		

BITFIELD	BITS	DESCRIPTION	DECODE
INLIM_CLK	7:6	Input Current Limit Soft-Start Period ( $\mu$ s) Between Consecutive Increments of 25mA	0b00: 8 0b01: 256 0b10: 1024 0b11: 4096
OTG_ILIM	5:3	OTG Mode Current Limit Setting (mA)	0b000: 500 0b001: 900 0b010: 1200 0b011: 1500 0b100: 2000 0b101: 2250 0b110: 2500 0b111: 3000
MINVSYS	2:0	Minimum System Regulation Voltage (V)	2 Cell Battery 0b000: 5.535 0b001: 5.740 0b010: 5.945 0b011: 6.150 0b100: 6.355 0b101: 6.560 0b110: 6.765 0b111: 6.970 3 Cell Battery 0b000: 8.303 0b001: 8.610 0b010: 8.918 0b011: 9.225 0b100: 9.533 0b101: 9.840 0b110: 10.148 0b111: 10.455

**CHG\_CNFG\_10 (0x20)**

Charger configuration 10

BIT	7	6	5	4	3	2	1	0
Field	SPR[1:0]		VCHGIN_REG[4:0]					DISKIP
Reset	0x0		0x04					0x0
Access Type	Write, Read		Write, Read					Write, Read

BITFIELD	BITS	DESCRIPTION	DECODE
SPR	7:6	Spare Bit	
VCHGIN_REG	5:1	CHGIN Voltage Regulation Threshold (V)	0x00: 4.025 0x01: 4.200 0x02: 4.375 0x03: 4.550 0x04: 4.725 0x05: 4.900 0x06: 5.425 0x07: 5.950 0x08: 6.475 0x09: 7.000 0x0A: 7.525 0x0B: 8.050 0x0C: 8.575 0x0D: 9.100 0x0E: 9.625 0x0F: 10.150 0x10: 10.675 0x11: 10.950 0x12: 11.550 0x13: 12.150 0x14: 12.750 0x15: 13.350 0x16: 13.950 0x17: 14.550 0x18: 15.150 0x19: 15.750 0x1A: 16.350 0x1B: 16.950 0x1C: 17.550 0x1D: 18.150 0x1E: 18.750 0x1F: 19.050
DISKIP	0	Charger Skip Mode Disable	0b0: Autoskip mode 0b1: Disable skip mode

## Applications Information

### Inductor Selection

Buck-boost allows a range of inductance for different combinations of switching frequency and maximum nominal CHGIN voltage. See [Table 11](#) for recommendations. The lower the inductor DCR is, the higher the buck-boost efficiency is. The user needs to weigh the trade-offs between inductor size and DCR value and choose a suitable inductor for the buck-boost. See [Table 12](#) for inductor recommendations.

**Table 11. Recommended Inductance for Combinations of Switching Frequency and Maximum Nominal CHGIN Voltage**

SWITCHING FREQUENCY (kHz)	MAXIMUM NOMINAL CHGIN VOLTAGE (V)	RECOMMENDED NOMINAL INDUCTANCE (μH)
600	15 or lower	2.2, 3.3
	Higher than 15	3.3

**Table 12. Suggested Inductors**

ROOT PART NUMBER	MFGR.	SERIES	NOMINAL INDUCTANCE (μH)	TYPICAL DC RESISTANCE (mΩ)	CURRENT RATING (A) -30% (ΔL/L)	CURRENT RATING (A) ΔT = +40°C RISE	DIMENSIONS L x W x H (mm)
MAX77960	Coilcraft	XAL4020-222ME	2.2	35.2	5.6	5.5	4.0 x 4.0 x 2.1
	Coilcraft	XAL4030-332ME	3.3	26.0	5.5	6.6	4.0 x 4.0 x 3.1
MAX77961	Cyntec	CMLE063T2R2-063	2.2	11.0	14.0	10.0	6.95 x 6.6 x 2.8
	Pulse	PA5007.332NLT	3.3	16.3	15.0	10.0	7.8 x 7.6 x 2.9

### CHGIN Capacitor Selection

The CHGIN capacitor, C<sub>CHGIN</sub>, reduces the current peaks drawn from the input power source and reduces switching noise in the device. In OTG mode, it also reduces the output voltage ripple and ensures regulation loop stability. The impedance of C<sub>CHGIN</sub> at the switching frequency should be kept very low. Ceramic capacitors with X5R or X7R dielectrics are highly recommended due to their small size, low ESR, and small temperature coefficients. For most applications, 1 x 10μF (1210) or 1 x 10μF (1206) or 2 x 10μF (0805) capacitors are sufficient. See [Table 13](#) for CHGIN capacitor recommendations.

**Table 13. Suggested CHGIN Capacitors**

MFGR.	SERIES	NOMINAL CAPACITANCE (μF)	RATED VOLTAGE (V)	TEMPERATURE CHARACTERISTICS	CASE SIZE (in)	DIMENSIONS L x W x H (mm)
Murata	GRM32ER7YA106KA12	10	35	X7R	1210	3.2 x 2.5 x 2.5
Murata	GRT31CR6YA106KE01	10	35	X5R	1206	3.2 x 1.6 x 1.6
Murata	GRM21BR6YA106ME43	10	35	X5R	0805	2.0 x 1.25 x 1.25

### SYS Capacitor Selection

The SYS capacitor, C<sub>SYS</sub>, is required to keep the output voltage ripple small and to ensure regulation loop stability. The C<sub>SYS</sub> must have low impedance at the switching frequency. Ceramic capacitors with X5R or X7R dielectric are highly recommended due to their small size, low ESR, and small temperature coefficients. For stable operation, buck-boost requires 40μF of minimum effective output capacitance. Considering the DC bias characteristic of ceramic capacitors, 2 x 47μF (1210) or 3 x 47μF (1206) or 7 x 22μF (0805) capacitors are recommended for 2-cell applications, and 3 x 47μF (1210) or 4 x 47μF (1206) capacitors are recommended for 3-cell applications. See [Table 14](#) for SYS capacitor

recommendations.

**Table 14. Suggested SYS Capacitors**

MFGR.	SERIES	NOMINAL CAPACITANCE (μF)	RATED VOLTAGE (V)	TEMPERATURE CHARACTERISTICS	CASE SIZE (in)	DIMENSIONS L x W x H (mm)
Taiyo Yuden	EMK325ABJ476MM8P	47	16	X5R	1210	3.2 x 2.5 x 2.5
Murata	GRM31CR61C476ME44	47	16	X5R	1206	3.2 x 1.6 x 1.6
Murata	GRM21BR61C226ME44	22	16	X5R	0805	2.0 x 1.25 x 1.25

### Battery Insertion Protection

When the battery hot inserts into the MAX77960/MAX77961, it creates high inrush current flowing through the body diode of Q<sub>BAT</sub> FET. The inrush current peaks at tens of amperes and lasts for less than a few hundreds of microseconds. Such current can possibly damage the Q<sub>BAT</sub> FET. For IC protection, the following battery insertion protection is required on the board:

- For system designs with a 2S battery, include an external 3A Schottky diode from BATT to SYS. The Schottky diode has low forward voltage drop when conducting high current in the forward direction. It diverts the inrush current from BATT to SYS at battery insertion. The inrush current flowing through the Q<sub>BAT</sub> FET is greatly reduced and therefore the IC is protected. See [Figure 14](#).
- For system designs with a 3S battery, the inrush current is higher than a 2S battery due to higher battery voltage. In addition to the 3A Schottky diode from BATT to SYS, it is required to include an inrush protection circuit. The inrush protection circuit consists of an FET and RC network. See [Figure 15](#) for a complete solution. At battery hot insertion, V<sub>GS</sub> of the FET is slowly charged by the RC network. The FET gradually turns on and limits the inrush current. For FET selection, check the current and voltage rating of the FET to guarantee that it satisfies the system specification.

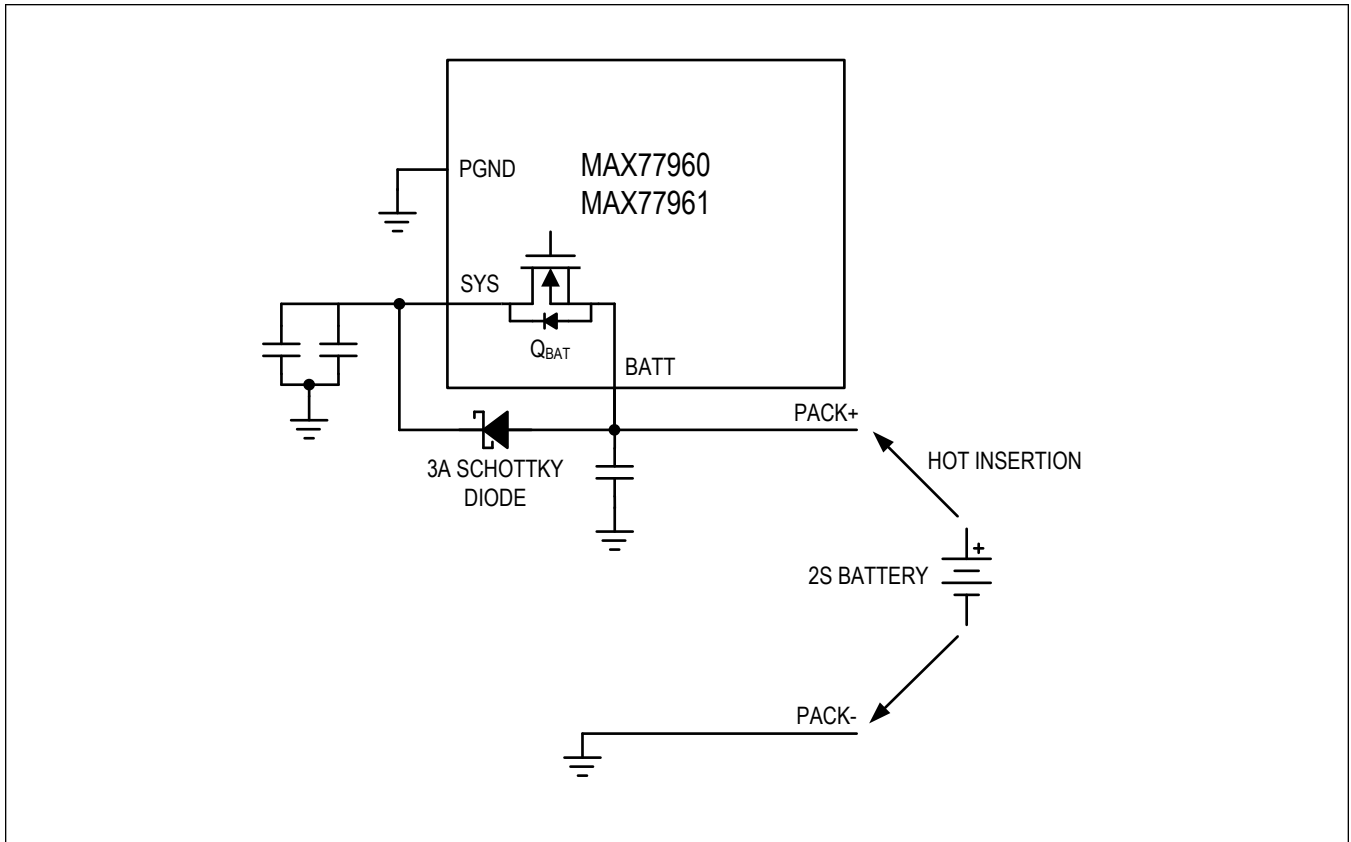

Figure 14. Battery Insertion Protection with 2S Battery

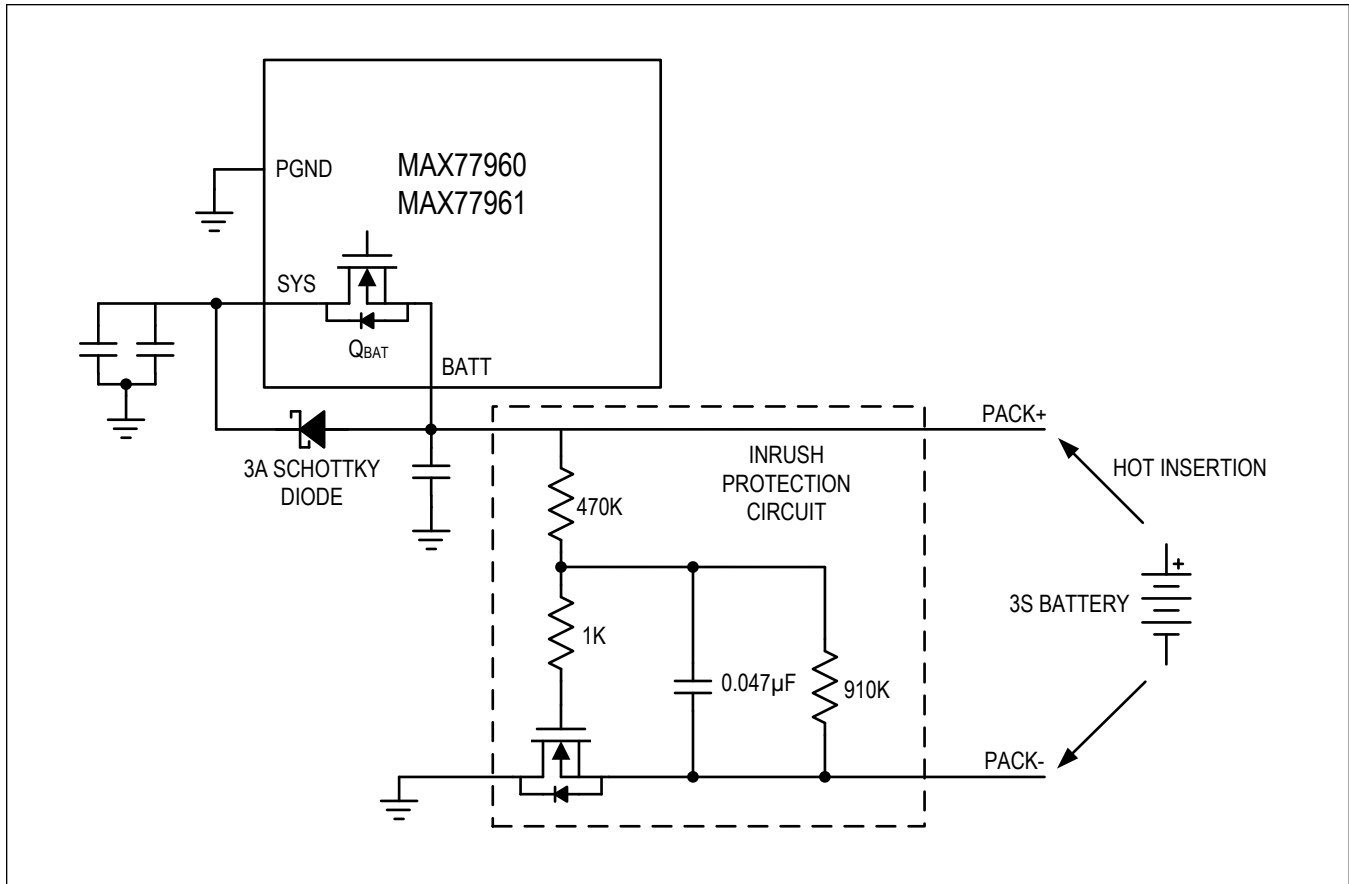

Figure 15. Battery Insertion Protection with 3S Battery

## PCB Layout Guidelines

Careful circuit board layout is critical to achieve low switching power losses and clean, stable operation. [Figure 16](#) shows a PCB layout example.

When designing the PCB, follow these guidelines:

1. Place the CHGIN capacitor ( $C_{CHGIN}$ ) and SYS capacitors ( $C_{SYS}$ ) immediately next to the CHGIN pin and SYS pin of the IC, respectively. Since the IC operates at a high switching frequency, this placement is critical for minimizing parasitic inductance within the input and output current loops which can cause high voltage spikes and can damage the internal switching MOSFETs.
2. Place the inductor next to the LX pins and make the traces between the LX pins and the inductor short and wide to minimize PCB trace impedance. Excessive PCB impedance reduces converter efficiency. When routing LX traces on a separate layer, make sure to include enough vias to minimize trace impedance. Routing LX traces on multiple layers is recommended to further reduce trace impedance. Furthermore, do not make LX traces take up an excessive amount of area. The voltage on this node switches very quickly and additional area creates more radiated emissions.
3. Route LX nodes to their corresponding bootstrap capacitors ( $C_{BST}$ ) as short as possible. Prioritize  $C_{BST}$  placement to reduce trace length to the IC.
4. Route CSINP and CSINN traces as symmetrical as possible. Having the same trace parasitics improves accuracy of the differential CHGIN current sensing.
5. Place the PVL capacitor ( $C_{PVL}$ ) immediately next to the PVL pin. Proximity to the IC provides a stable supply for the internal circuitry.
6. Place the BATT capacitor ( $C_{BATT}$ ) and SYSA capacitor ( $C_{SYSA}$ ) immediately next to the BATT pin and SYSA pin of the IC, respectively.

7. Connect BATSP and BATSN as close as possible to the battery connector. This optimizes remote sense of the battery voltage.
8. Keep the power traces and load connections short and wide. This is essential for high converter efficiency.
9. Do not neglect ceramic capacitor DC voltage derating. Choose capacitor values and case sizes carefully. See the [SYS Capacitor Selection](#) section and refer to [Tutorial 5527](#) for more information.

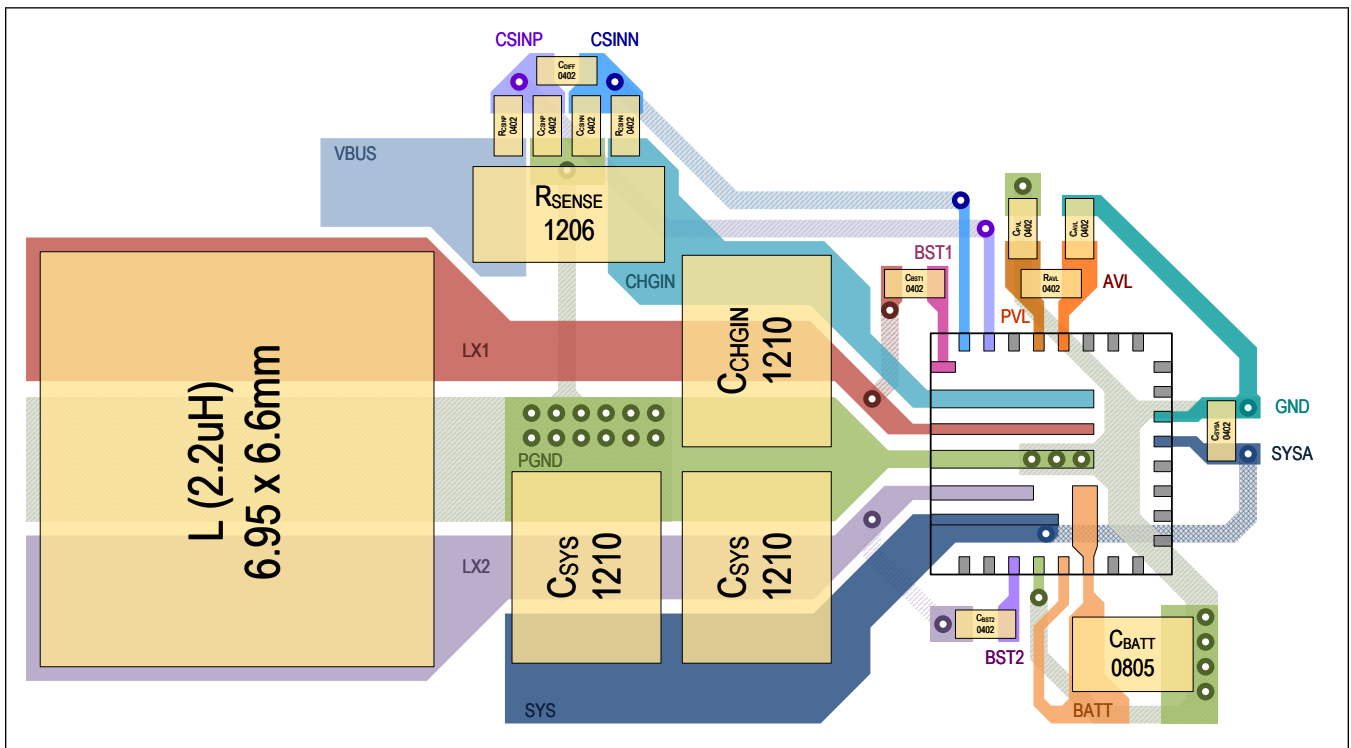
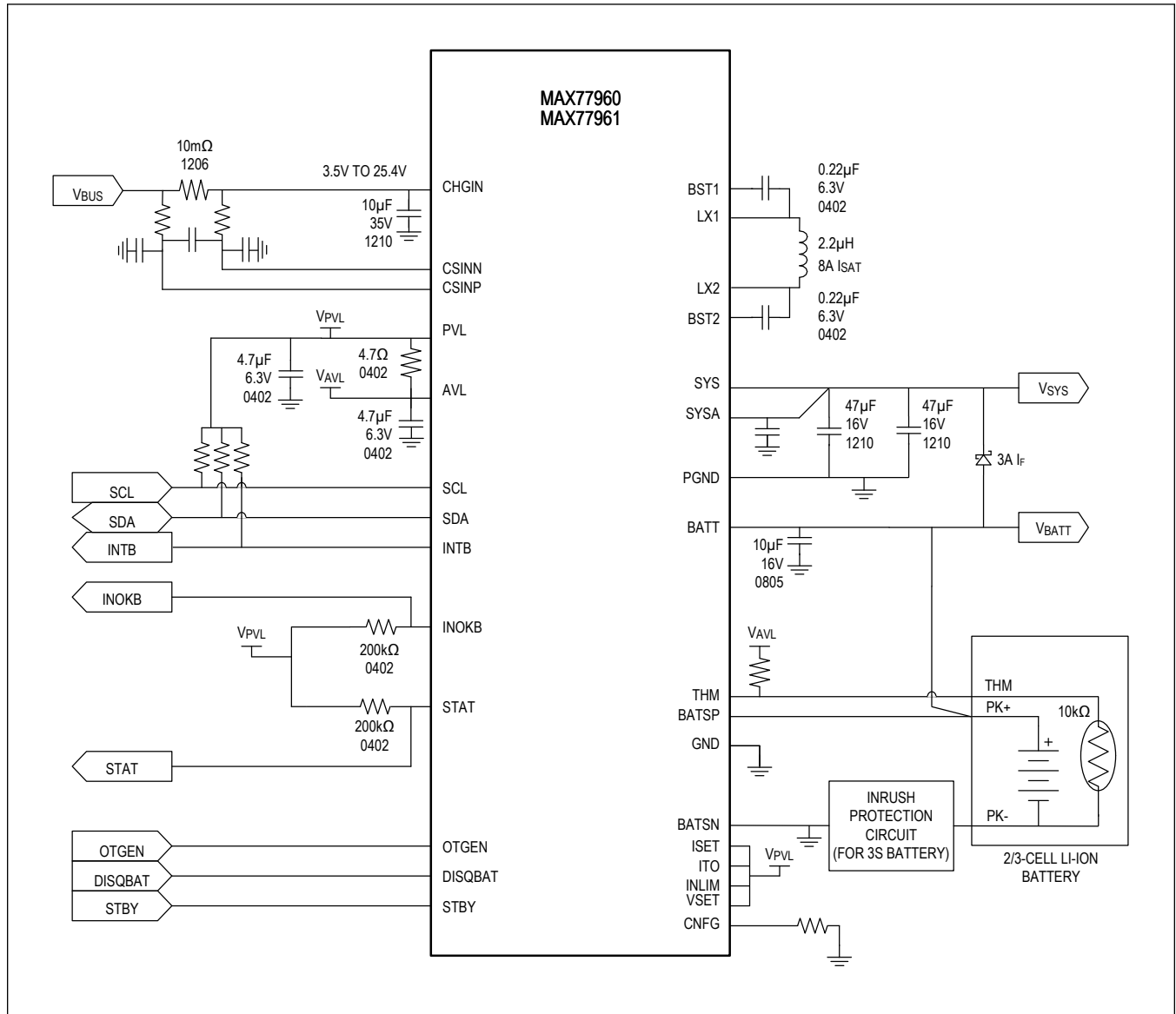

Figure 16. PCB Layout Example

Typical Application Circuits

Wide-Input I<sup>2</sup>C Programmable Charger



Typical Application Circuits (continued)

Wide-Input I<sup>2</sup>C Programmable Charger with Charger Disabled

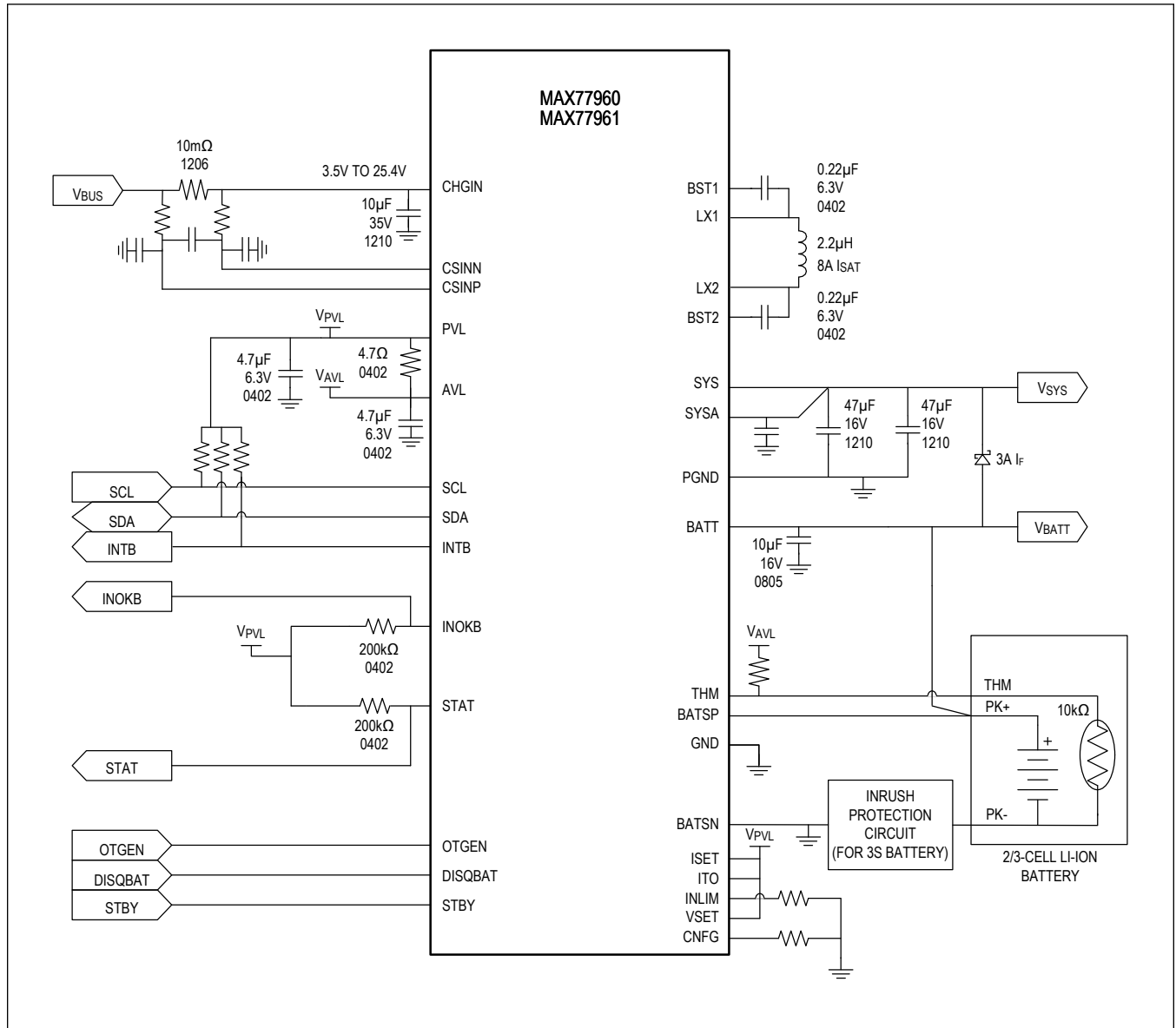

Typical Application Circuits (continued)

Wide-Input Autonomous Charger

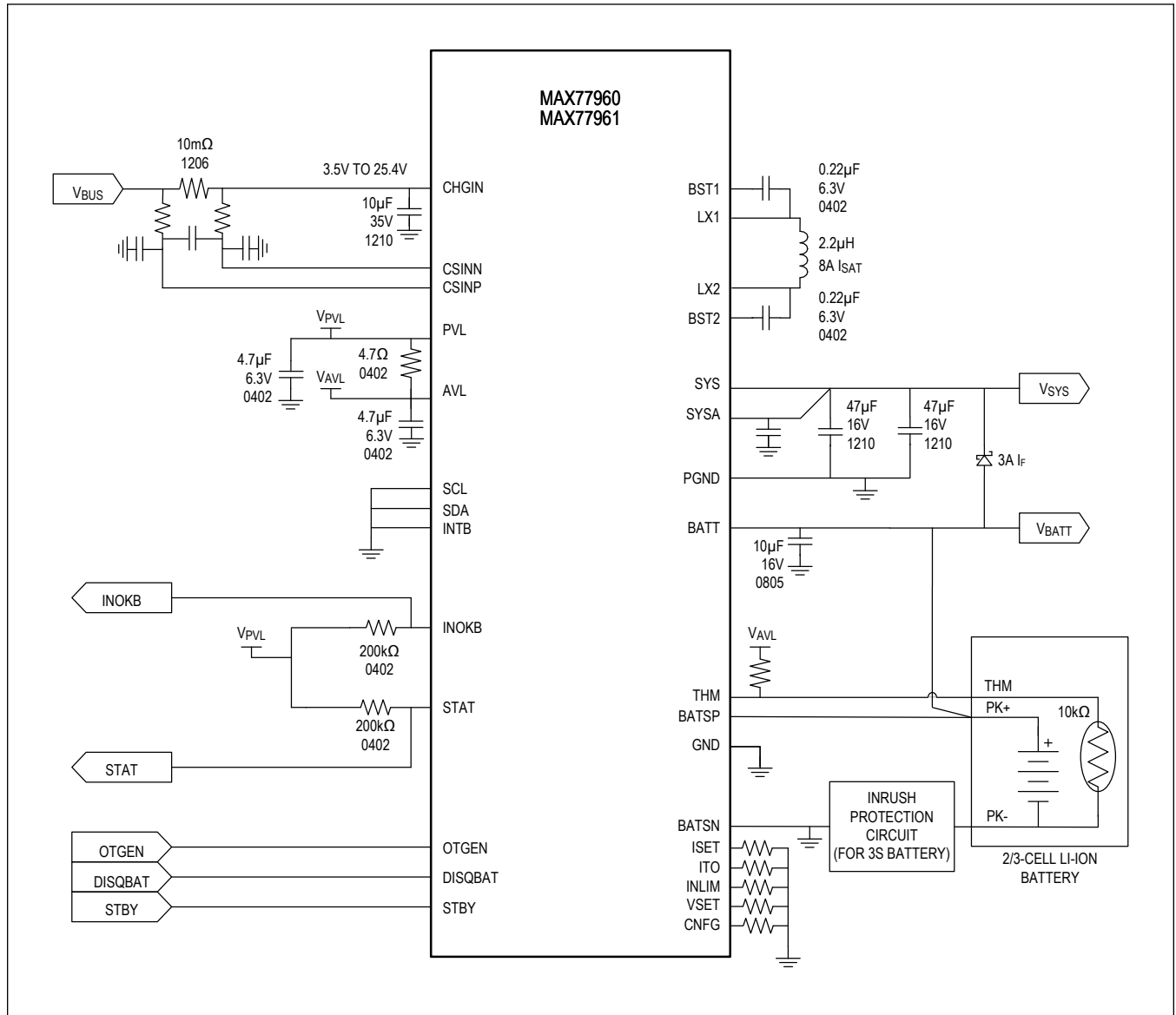

MAX77960/MAX77961

25V<sub>IN</sub>, 3A<sub>OUT</sub> to 6A<sub>OUT</sub>, USB-C Buck-Boost  
Charger with Integrated FETs for 2S/3S Li-Ion  
Batteries

### Ordering Information

PART NUMBER	TEMP RANGE	PIN-PACKAGE	SWITCHING FREQUENCY	AUTONOMOUS OPERATION SUPPORTED	MAXIMUM CHARGING CURRENT
<b>MAX77960</b> EFV06+	-40°C to +85°C	4mm x 4mm, 30-Lead FC2QFN	600kHz	Yes	3A
MAX77960EFV06+T	-40°C to +85°C	4mm x 4mm, 30-Lead FC2QFN	600kHz	Yes	3A
<b>MAX77961</b> EFV06+	-40°C to +85°C	4mm x 4mm, 30-Lead FC2QFN	600kHz	Yes	6A
MAX77961EFV06+T	-40°C to +85°C	4mm x 4mm, 30-Lead FC2QFN	600kHz	Yes	6A

+Denotes a lead(Pb)-free/RoHS-compliant package.

T = Tape and reel.

## Revision History

REVISION NUMBER	REVISION DATE	DESCRIPTION	PAGES CHANGED
0	9/20	Initial release	—
1	6/24	Updated <i>Datasheet title</i> for the entire document, <i>Simplified Block Diagram</i> , <i>Absolute Maximum Ratings</i> , <i>Package Information</i> , <i>Electrical Characteristics</i> table, <i>Typical Operating Characteristics</i> Global Conditions, <i>Pin Description</i> , <i>Thermistor Input (THM)</i> , <i>Disable Thermistor Monitoring</i> , <i>Switch Mode Charger</i> , <i>SYS Regulation Voltage</i> , <i>Battery Differential Voltage Sense (BATSP, BATSN)</i> , <i>Reverse Buck Mode (OTG)</i> , <i>V<sub>SYS</sub> Undervoltage Lockout (V<sub>SYSUVLO</sub>)</i> , <i>Thermal Fault</i> , and <i>Communication Speed</i> sections in Detailed Description, <i>SWRST (0x1)</i> , <i>CHG_DETAILS_02 (0x15)</i> , <i>CHG_CFG_05 (0x1B)</i> , <i>CHG_CFG_06 (0x1C)</i> , and <i>CHG_CFG_08 (0x1E)</i> sections in <i>Register Map</i> , <i>CHGIN Capacitor Selection</i> , <i>Table 13</i> , and <i>PCB Layout Guidelines</i> sections in <i>Applications Information</i> . Added Disclaimer on Page 1, <i>Register Types and Reset Conditions</i> , and <i>Charger Register Write Protection</i> sections in Detailed Description.	1–82

## Looking for pricing, stock, or lifecycle information?

Click below to explore more details on WIN SOURCE:

 [View MAX77960EFV06+ on WIN SOURCE](#)

 [Analog Devices Inc. Information](#)

## Optimize Your Supply Chain with WIN SOURCE Solutions

-  Global Sourcing Solution
-  Obsolete Management
-  Cost Control Management
-  Shortage Management
-  Alternative Solution
-  Excess Inventory Management