



**THE DATASHEET OF
LTC2919HMS-2.5#PBF**



Precision Triple/Dual Input UV, OV and Negative Voltage Monitor

FEATURES

- Two Low Voltage Adjustable Inputs (0.5V)
- Accurate UVLO Provides a Third Monitor Input
- Open-Drain \overline{RST} , OUT1 and OUT2 Outputs
- Pin Selectable Input Polarity Allows Negative, UV and OV Monitoring
- Guaranteed Threshold Accuracy: $\pm 1.5\%$
- 6.5V Shunt Regulator for High Voltage Operation
- Low 50 μ A Quiescent Current
- Buffered 1V Reference for Negative Supply Offset
- Input Glitch Rejection
- Adjustable Reset Timeout Period
- Selectable Internal Timeout Saves Components
- Outputs Guaranteed Low with $V_{CC} = 0.5V$
- Space Saving 10-Lead 3mm \times 2mm DFN and MSOP Packages
- AEC-Q100 Qualified for Automotive Applications

APPLICATIONS

- Desktop and Notebook Computers
- Network Servers
- Core, I/O Monitor
- Automotive

DESCRIPTION

The LTC[®]2919 is a triple/dual input monitor intended for a variety of system monitoring applications. Polarity selection and a buffered reference output allow the LTC2919 to monitor positive and negative supplies for undervoltage (UV) and overvoltage (OV) conditions.

The two adjustable inputs have a nominal 0.5V threshold, featuring tight 1.5% threshold accuracy over the entire operating temperature range. Glitch filtering ensures outputs operate reliably without false triggering. An accurate threshold at the V_{CC} pin provides a third input supply monitor for a 2.5V, 3.3V or 5V supply.

Two independent output pins indicate the status of each adjustable input. A third common output provides a configurable reset timeout that may be set by an accurate internal 200ms timer, programmed with an external capacitor, or disabled for a fast response. A three-state input pin sets the input polarity of each adjustable input without requiring any external components.

The LTC2919 provides a highly versatile, precise, space-conscious, micropower solution for supply monitoring.

All registered trademarks and trademarks are the property of their respective owners. Protected by U.S. patents, including 6949965, 7292076.

TYPICAL APPLICATION

**3.3V UV/OV (Window) Monitor Application with
200ms Internal Timeout (3.3V Logic Out)**

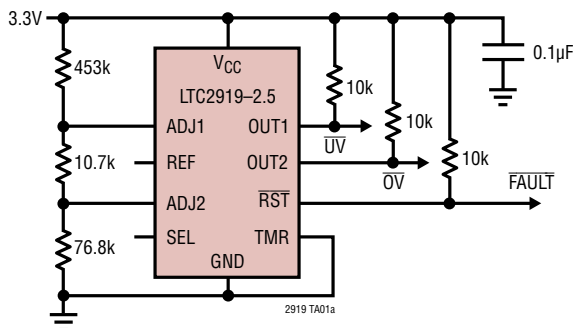

**SEL Pin Connection for Input Polarity
Combinations**

POLARITY		SEL PIN
ADJ1	ADJ2	
+	+	V_{CC}
+	-	OPEN
-	-	GND

LTC2919

ABSOLUTE MAXIMUM RATINGS (Notes 1, 2)

Terminal Voltages

V_{CC} (Note 3).....	-0.3V to 6V
OUT1, OUT2, \overline{RST}	-0.3V to 7.5V
ADJ1, ADJ2.....	-0.3V to 7.5V
TMR, SEL.....	-0.3V to ($V_{CC} + 0.3V$)

Terminal Currents

I_{CC} (Note 3).....	$\pm 10mA$
I_{REF}	$\pm 1mA$
ADJ1, ADJ2.....	-1mA

Operating Temperature Range

LTC2919C	0°C to 70°C
LTC2919I	-40°C to 85°C
LTC2919H	-40°C to 125°C
Maximum Junction Temperature	150°C
Storage Temperature Range	-65°C to 150°C
Lead Temperature (Soldering, 10 sec)	
MSOP-10.....	300°C

PIN CONFIGURATION

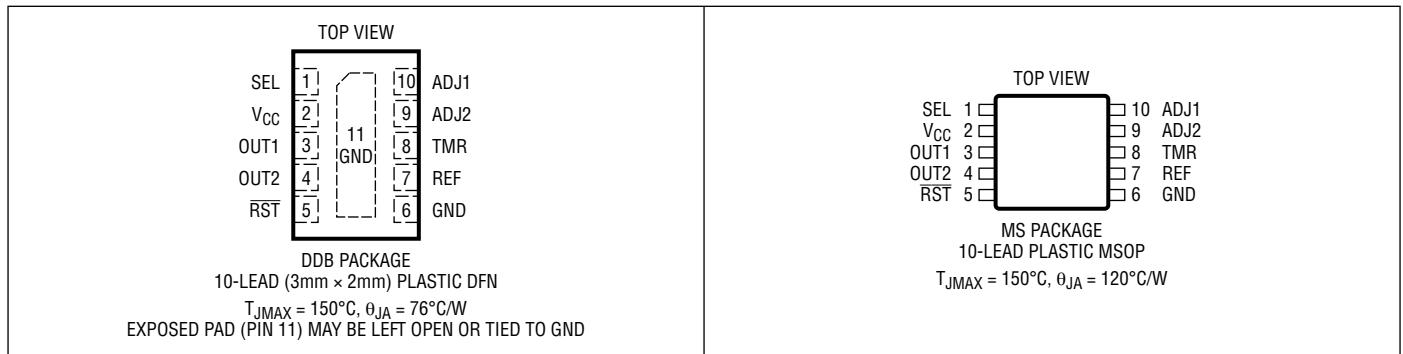

ORDER INFORMATION

LEAD FREE FINISH	TAPE AND REEL	PART MARKING*	PACKAGE DESCRIPTION	TEMPERATURE RANGE
LTC2919CDDB-2.5#TRMPBF	LTC2919CDDB-2.5#TRPBF	LDGT	10-Lead (3mm x 2mm) Plastic DFN	0°C to 70°C
LTC2919IDDB-2.5#TRMPBF	LTC2919IDDB-2.5#TRPBF	LDGT	10-Lead (3mm x 2mm) Plastic DFN	-40°C to 85°C
LTC2919HDDB-2.5#TRMPBF	LTC2919HDDB-2.5#TRPBF	LDGT	10-Lead (3mm x 2mm) Plastic DFN	-40°C to 125°C
LTC2919CDDB-3.3#TRMPBF	LTC2919CDDB-3.3#TRPBF	LDMW	10-Lead (3mm x 2mm) Plastic DFN	0°C to 70°C
LTC2919IDDB-3.3#TRMPBF	LTC2919IDDB-3.3#TRPBF	LDMW	10-Lead (3mm x 2mm) Plastic DFN	-40°C to 85°C
LTC2919HDDB-3.3#TRMPBF	LTC2919HDDB-3.3#TRPBF	LDMW	10-Lead (3mm x 2mm) Plastic DFN	-40°C to 125°C
LTC2919CDDB-5#TRMPBF	LTC2919CDDB-5#TRPBF	LDMX	10-Lead (3mm x 2mm) Plastic DFN	0°C to 70°C
LTC2919IDDB-5#TRMPBF	LTC2919IDDB-5#TRPBF	LDMX	10-Lead (3mm x 2mm) Plastic DFN	-40°C to 85°C
LTC2919HDDB-5#TRMPBF	LTC2919HDDB-5#TRPBF	LDMX	10-Lead (3mm x 2mm) Plastic DFN	-40°C to 125°C
LTC2919CMS-2.5#PBF	LTC2919CMS-2.5#TRPBF	LTDGS	10-Lead Plastic MSOP	0°C to 70°C
LTC2919IMS-2.5#PBF	LTC2919IMS-2.5#TRPBF	LTDGS	10-Lead Plastic MSOP	-40°C to 85°C
LTC2919HMS-2.5#PBF	LTC2919HMS-2.5#TRPBF	LTDGS	10-Lead Plastic MSOP	-40°C to 125°C
LTC2919CMS-3.3#PBF	LTC2919CMS-3.3#TRPBF	LTDMT	10-Lead Plastic MSOP	0°C to 70°C
LTC2919IMS-3.3#PBF	LTC2919IMS-3.3#TRPBF	LTDMT	10-Lead Plastic MSOP	-40°C to 85°C
LTC2919HMS-3.3#PBF	LTC2919HMS-3.3#TRPBF	LTDMT	10-Lead Plastic MSOP	-40°C to 125°C

LEAD FREE FINISH	TAPE AND REEL	PART MARKING*	PACKAGE DESCRIPTION	TEMPERATURE RANGE
LTC2919CMS-5#PBF	LTC2919CMS-5#TRPBF	LTD MV	10-Lead Plastic MSOP	0°C to 70°C
LTC2919IMS-5#PBF	LTC2919IMS-5#TRPBF	LTD MV	10-Lead Plastic MSOP	-40°C to 85°C
LTC2919HMS-5#PBF	LTC2919HMS-5#TRPBF	LTD MV	10-Lead Plastic MSOP	-40°C to 125°C

AUTOMOTIVE PRODUCTS**

LTC2919IDDB-2.5#WTRMPBF	LTC2919IDDB-2.5#WTRPBF	LDGT	10-Lead (3mm × 2mm) Plastic DFN	-40°C to 85°C
LTC2919HDDB-2.5#WTRMPBF	LTC2919HDDB-2.5#WTRPBF	LDGT	10-Lead (3mm × 2mm) Plastic DFN	-40°C to 125°C
LTC2919IDDB-3.3#WTRMPBF	LTC2919IDDB-3.3#WTRPBF	LDMW	10-Lead (3mm × 2mm) Plastic DFN	-40°C to 85°C
LTC2919HDDB-3.3#WTRMPBF	LTC2919HDDB-3.3#WTRPBF	LDMW	10-Lead (3mm × 2mm) Plastic DFN	-40°C to 125°C
LTC2919IDDB-5#WTRMPBF	LTC2919IDDB-5#WTRPBF	LDMX	10-Lead (3mm × 2mm) Plastic DFN	-40°C to 85°C
LTC2919HDDB-5#WTRMPBF	LTC2919HDDB-5#WTRPBF	LDMX	10-Lead (3mm × 2mm) Plastic DFN	-40°C to 125°C

Contact the factory for parts specified with wider operating temperature ranges. *The temperature grade is identified by a label on the shipping container.

Tape and reel specifications. Some packages are available in 500 unit reels through designated sales channels with #TRMPBF suffix.

**Versions of this part are available with controlled manufacturing to support the quality and reliability requirements of automotive applications. These models are designated with a #W suffix. Only the automotive grade products shown are available for use in automotive applications. Contact your local Analog Devices account representative for specific product ordering information and to obtain the specific Automotive Reliability reports for these models.

ELECTRICAL CHARACTERISTICS

The ● denotes the specifications which apply over the full operating temperature range, otherwise specifications are at $T_A = 25^\circ\text{C}$. $V_{CC} = 2.5\text{V}$ (LTC2919-2.5), $V_{CC} = 3.3\text{V}$ (LTC2919-3.3), $V_{CC} = 5\text{V}$ (LTC2919-5), $ADJ1 = ADJ2 = 0.55\text{V}$, SEL = floating, unless otherwise noted. (Note 2)

SYMBOL	PARAMETER	CONDITIONS	MIN	TYP	MAX	UNITS
$V_{CC(MIN)}$	Operating Supply Voltage	RST, OUT1, OUT2 in Correct State	● 0.5			V
$V_{CC(SHUNT)}$	V_{CC} Shunt Regulation Voltage	$I_{CC} = 1\text{mA}$, $I_{REF} = 0$	● 6.0	6.5	7.1	V
I_{CC}	V_{CC} Input Current	2.175V < V_{CC} < 6V (C-Grade, I-Grade) 2.175V < V_{CC} < 6V (H-Grade)	●	50	220	μA
V_{RT}	ADJ Input Threshold		● 495.0	500	505.0	mV
ΔV_{RT}	ADJ Hysteresis (Note 4)	TMR = V_{CC}	492.5	500	507.5	mV
I_{ADJ}	ADJ Input Current	$V_{ADJ} = 0.55\text{V}$ (C-Grade, I-Grade) $V_{ADJ} = 0.55\text{V}$ (H-Grade)	●	0	±15	nA
$V_{CC(UVLO)}$	V_{CC} -10% UVLO Threshold	LTC2919-2.5 LTC2919-3.3 LTC2919-5	● 2.175 ● 2.871 ● 4.350	2.213 2.921 4.425	2.250 2.970 4.500	V
$\Delta V_{CC(UVLO)}$	UVLO Hysteresis (Note 4)	TMR = V_{CC}	0.3	0.7	2.0	%
V_{REF}	Buffered Reference Voltage	$V_{CC} > 2.175\text{V}$, $I_{REF} = \pm 1\text{mA}$	● 0.990 0.985	1.000 1.000	1.010 1.015	V
$I_{TMR(UP)}$	TMR Pull-Up Current	$V_{TMR} = 1\text{V}$	● -1.5	-2.2	-2.9	μA
$I_{TMR(DOWN)}$	TMR Pull-Down Current	$V_{TMR} = 1\text{V}$	● 1.5	2.2	2.9	μA
$t_{RST(EXT)}$	Reset Timeout Period, External	$C_{TMR} = 2.2\text{nF}$	● 15	20	27	ms
$t_{RST(INT)}$	Reset Timeout Period, Internal	$V_{TMR} = 0\text{V}$	● 140	200	280	ms

ELECTRICAL CHARACTERISTICS The ● denotes the specifications which apply over the full operating temperature range, otherwise specifications are at $T_A = 25^\circ\text{C}$. $V_{CC} = 2.5\text{V}$ (LTC2919-2.5), $V_{CC} = 3.3\text{V}$ (LTC2919-3.3), $V_{CC} = 5\text{V}$ (LTC2919-5), $\text{ADJ1} = \text{ADJ2} = 0.55\text{V}$, $\text{SEL} = \text{floating}$, unless otherwise noted. (Note 2)

SYMBOL	PARAMETER	CONDITIONS		MIN	TYP	MAX	UNITS
$V_{\text{TMR(DIS)}}$	Timer Disable Voltage	V_{TMR} Rising	●	$V_{CC} - 0.40$	$V_{CC} - 0.20$	$V_{CC} - 0.10$	V
$\Delta V_{\text{TMR(DIS)}}$	Timer Disable Hysteresis	V_{TMR} Falling	●	40	100	160	mV
$V_{\text{TMR(INT)}}$	Timer Internal Mode Voltage	V_{TMR} Falling	●	0.10	0.20	0.40	V
$\Delta V_{\text{TMR(INT)}}$	Timer Internal Mode Hysteresis	V_{TMR} Rising	●	40	100	160	mV
t_{PROP}	ADJx Comparator Propagation Delay to OUT_x	ADJx Driven Beyond Threshold (V_{RTX}) by 5mV	●	50	150	800	μs
t_{UV}	V_{CC} Undervoltage Detect to $\overline{\text{RST}}$	V_{CC} Less Than UVLO Threshold ($V_{\text{CC(UVLO)}}$) by 1%	●	50	150	800	μs
V_{OL}	Output Voltage Low	$V_{CC} = 0.5\text{V}$, $I = 5\mu\text{A}$	●	0	0.01	0.15	V
		$V_{CC} = 1\text{V}$, $I = 100\mu\text{A}$	●	0	0.01	0.15	V
		$V_{CC} = 3\text{V}$, $I = 2500\mu\text{A}$	●	0	0.10	0.30	V
I_{OH}	Output Voltage High Leakage	Output = V_{CC} (C-Grade, I-Grade)	●		0	± 1	μA
		Output = V_{CC} (H-Grade)	●		0	± 5	μA

Three-State Input SEL

V_{IL}	Low Level Input Voltage		●	0		0.4	V
V_{IH}	High Level Input Voltage		●	1.4		V_{CC}	V
V_{Z}	Pin Voltage when Left in Open State	$I_{\text{SEL}} = 0\mu\text{A}$		0.8	0.9	1.0	V
$I_{\text{SEL(Z)}}$	Allowable Leakage When Open		●			± 5	μA
I_{SEL}	SEL Input Current	$\text{SEL} = V_{CC}$ or $\text{SEL} = \text{GND}$	●		± 17	± 25	μA

Note 1: Stresses beyond those listed under Absolute Maximum Ratings may cause permanent damage to the device. Exposure to any Absolute Maximum Rating condition for extended periods may affect device reliability and lifetime.

Note 2: All currents into pins are positive; all voltages are referenced to GND unless otherwise noted.

Note 3: V_{CC} maximum pin voltage is limited by input current. Since the V_{CC} pin has an internal 6.5V shunt regulator, a low impedance supply

which exceeds 6V may exceed the rated terminal current. Operation from higher voltage supplies requires a series dropping resistor. See Applications Information.

Note 4: Threshold voltages have no hysteresis unless the part is in comparator mode. Hysteresis is one-sided, affecting only invalid-to-valid transitions. See Applications Information.

TYPICAL PERFORMANCE CHARACTERISTICS $T_A = 25^\circ\text{C}$, unless otherwise noted.

ADJ Threshold Voltage vs Temperature

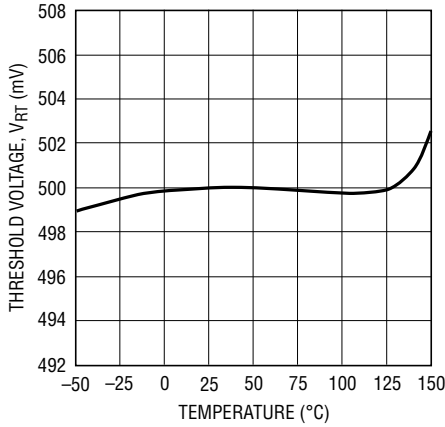

2919 G01

V_{CC} UVLO Threshold Variation vs Temperature

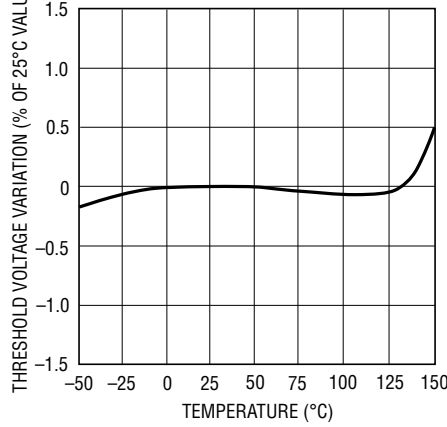

2919 G02

REF Output Voltage vs Temperature

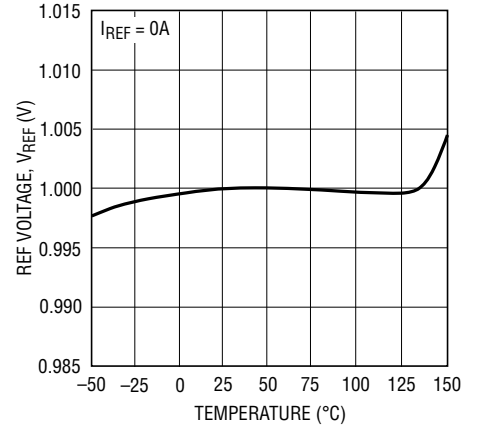

2919 G03

REF Output Load Regulation

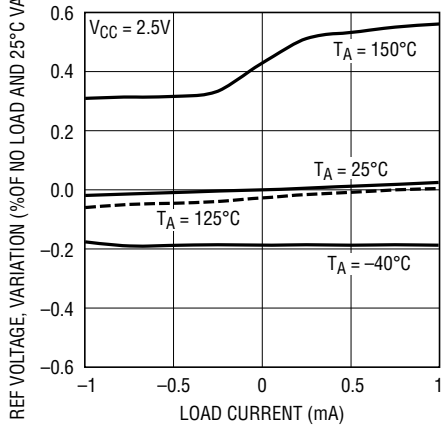

2919 G04

REF Output Line Regulation

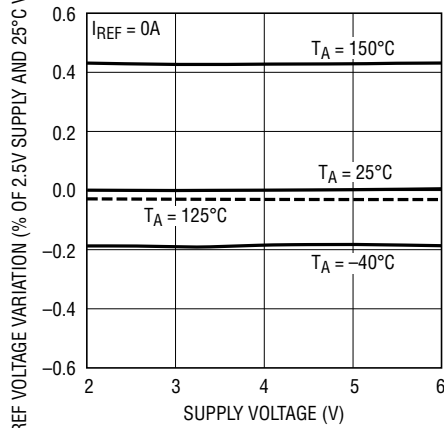

2919 G05

Quiescent Supply Current vs Temperature

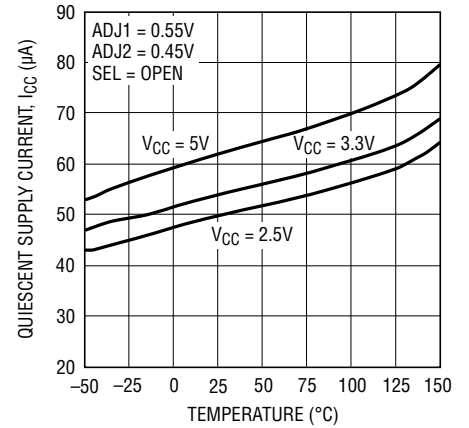

2919 G06

Propagation Delay vs Overdrive

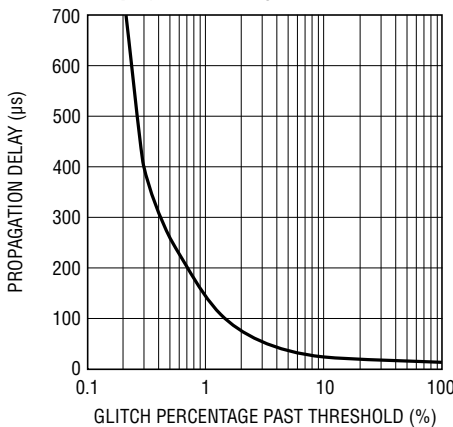

2919 G07

Reset Timeout Period vs Capacitance

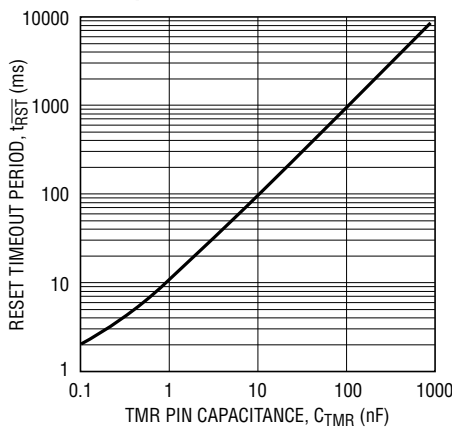

2919 G08

Reset Timeout Period vs Temperature

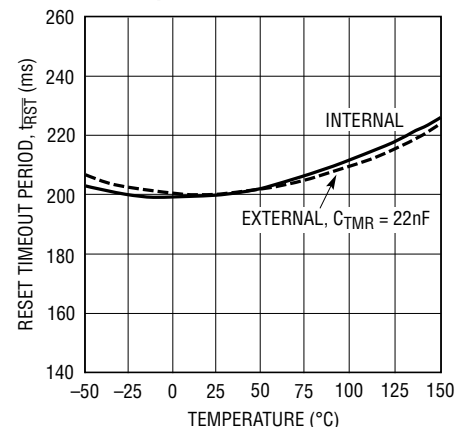

2919 G09

TYPICAL PERFORMANCE CHARACTERISTICS $T_A = 25^\circ\text{C}$, unless otherwise noted.

Shunt Regulation Voltage vs Temperature

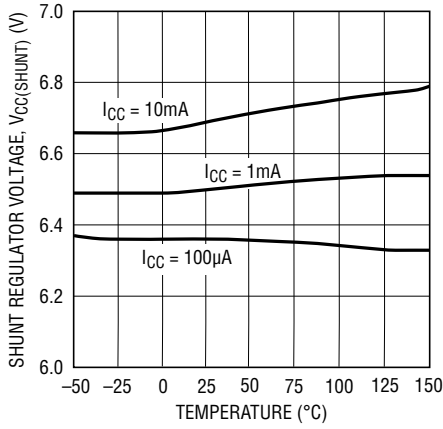

2919 G10

Shunt Regulation Voltage vs Supply Current

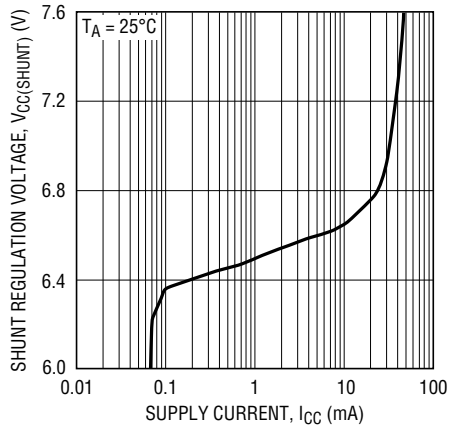

2919 G11

OUT1, OUT2, $\overline{\text{RST}}$ Output Voltage vs V_{CC}

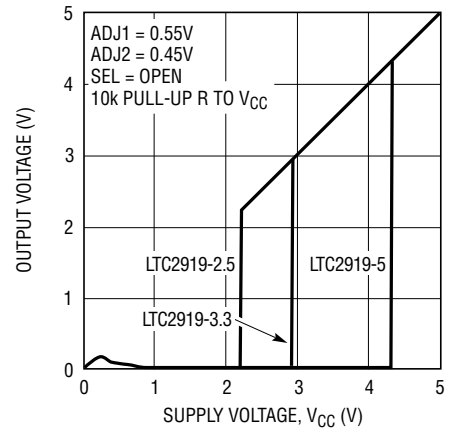

2919 G12

OUT1, OUT2, $\overline{\text{RST}}$ Output Voltage vs V_{CC}

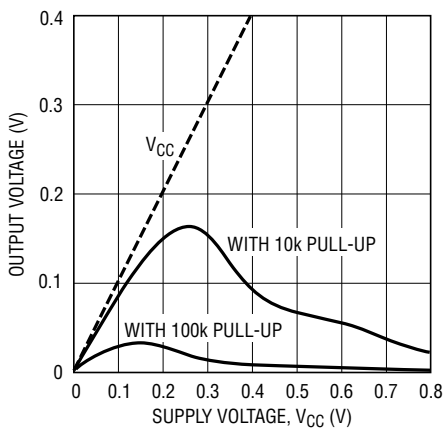

2919 G13

OUT1, OUT2, $\overline{\text{RST}}$ Pull-Down Current vs V_{CC}

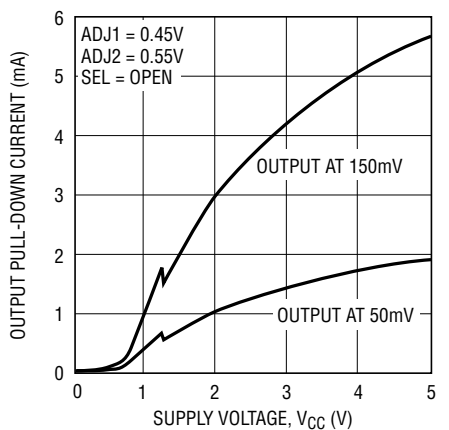

2919 G14

OUT1, OUT2, $\overline{\text{RST}}$ Pull-Down Current vs V_{CC}

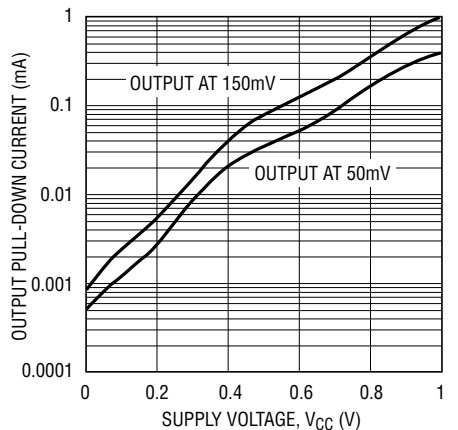

2919 G15

OUT1, OUT2, $\overline{\text{RST}}$ V_{OL} vs Output Sink Current

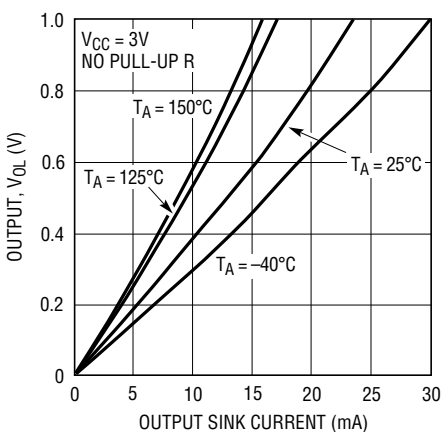

2919 G16

I_{SEL} vs Temperature

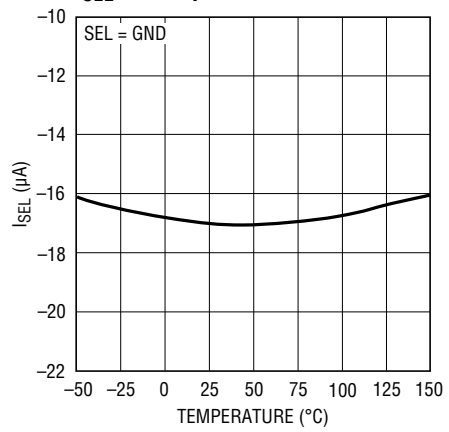

2919 G17

I_{SEL} vs Temperature

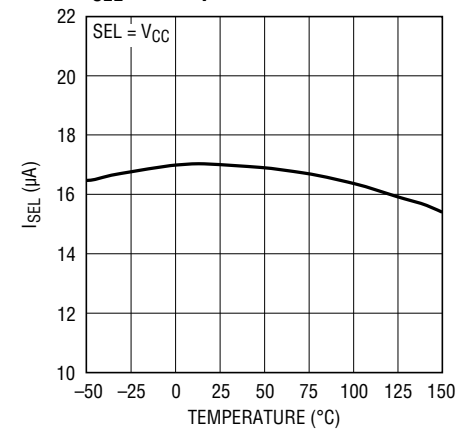

2919 G18

PIN FUNCTIONS (DFN/MSOP)

SEL (Pin 1): Input Polarity Select Three-State Input. Connect to V_{CC} , GND or leave unconnected in open state to select one of three possible input polarity combinations (refer to Table 1).

V_{CC} (Pin 2): Power Supply. Bypass this pin to ground with a 0.1 μ F (or greater) capacitor. Operates as a direct supply input for voltages up to 6V. Operates as a shunt regulator for supply voltages greater than 6V and should have a resistor between this pin and the supply to limit V_{CC} input current to no greater than 10mA. When used without a current-limiting resistor, pin voltage must not exceed 6V. UVLO options allow V_{CC} to be used as an accurate third fixed -10% UV supply monitor.

OUT1 (Pin 3): Open-Drain Logic Output 1. Asserts low when positive polarity ADJ1 voltage is below threshold or negative polarity ADJ1 voltage is above threshold. Requires an external pull-up resistor and may be pulled above V_{CC} .

OUT2 (Pin 4): Open-Drain Logic Output 2. Asserts low when positive polarity ADJ2 voltage is below threshold or negative polarity ADJ2 voltage is above threshold. Requires an external pull-up resistor and may be pulled above V_{CC} .

\overline{RST} (Pin 5): Open-Drain Inverted Reset Logic Output. Asserts low when any positive polarity input voltage is below threshold or any negative polarity input voltage is above threshold or V_{CC} is below UVLO threshold. Held low for a timeout period after all voltage inputs are valid. Requires an external pull-up resistor and may be pulled above V_{CC} .

GND (Pin 6): Device Ground.

REF (Pin 7): Buffered Reference Output. 1V nominal reference used for the offset of negative-monitoring applications. The buffered reference can source and sink up to 1mA. The reference can drive a capacitive load of up to 1000pF. Larger capacitance may degrade transient performance. This pin does not require a bypass capacitor, nor is one recommended. Leave open if unused.

TMR (Pin 8): Reset Timeout Control. Attach an external capacitor (C_{TMR}) to GND to set a reset timeout period of 9ms/nF. A low leakage ceramic capacitor is recommended for timer accuracy. Capacitors larger than 1 μ F (9 second timeout) are not recommended. See Applications Information for further details. Leaving this pin open generates a minimum timeout of approximately 400 μ s. A 2.2nF capacitor will generate a 20ms timeout. Tying this pin to ground will enable the internal 200ms timeout. Tying this pin to V_{CC} will disable the reset timer and put the part in comparator mode. Signals from the comparator outputs will then go directly to \overline{RST} .

ADJ2 (Pin 9): Adjustable Voltage Input 2. Input to voltage monitor comparator 2 (0.5V nominal threshold). The polarity of the input is selected by the state of the SEL pin (refer to Table 1). Tie to GND if unused (with SEL = GND or Open).

ADJ1 (Pin 10): Adjustable Voltage Input 1. Input to voltage monitor comparator 1 (0.5V nominal threshold). The polarity of the input is selected by the state of the SEL pin (refer to Table 1). Tie to REF if unused (with SEL = V_{CC} or Open).

Exposed Pad (Pin 11, DFN Only): The Exposed Pad may be left unconnected. For better thermal contact, tie to a PCB trace. This trace must be grounded or unconnected.

BLOCK DIAGRAM

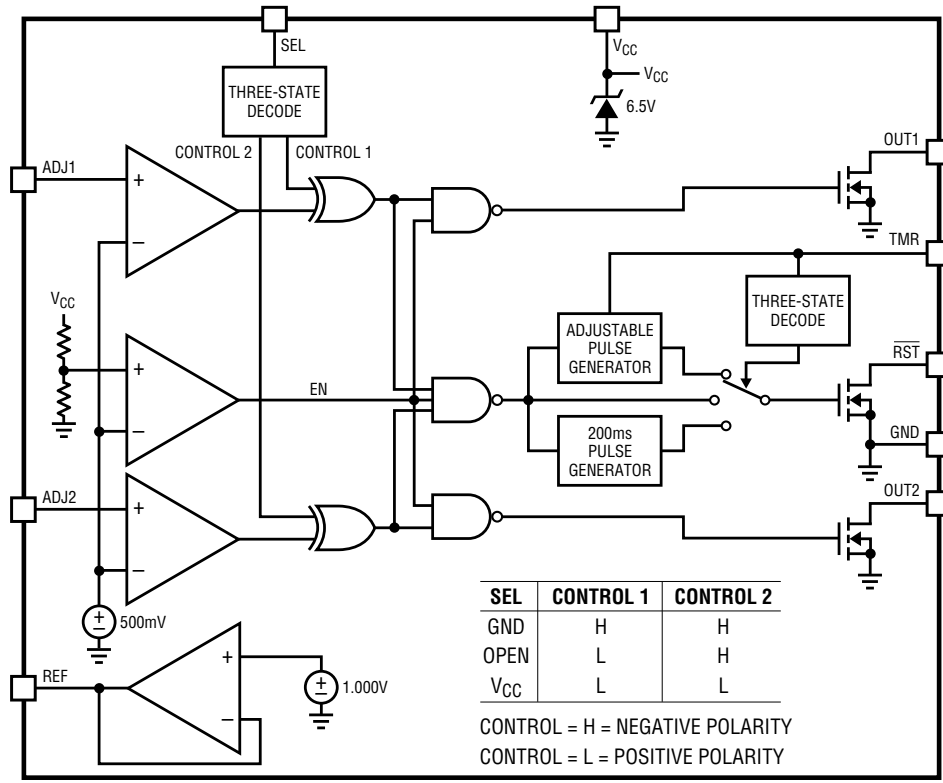

2919 8D

TIMING DIAGRAM

Positive Polarity Input Timing

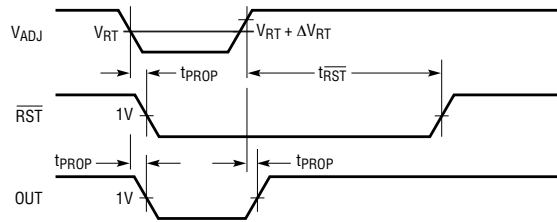

Negative Polarity Input Timing

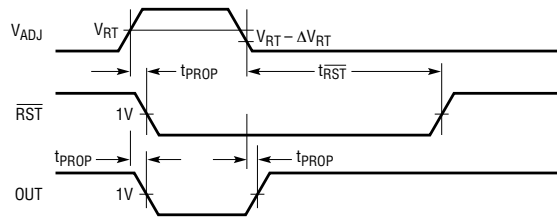

UVLO Timing

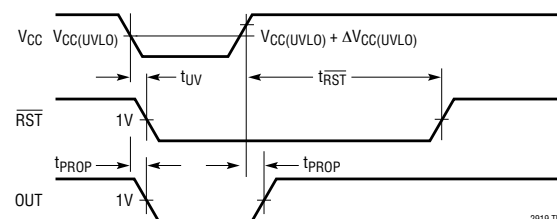

- NOTES:**
1. ΔV_{RT} AND $\Delta V_{CC(UVLO)} = 0$, except in Comparator Mode
 2. IN COMPARATOR MODE, $t_{RST} = t_{PROP}$.

2919 7D

APPLICATIONS INFORMATION

The LTC2919 is a low power, high accuracy triple/dual supply monitor with two adjustable inputs and an accurate UVLO that can monitor a third supply. Reset timeout may be selected with an external capacitor, set to an internally generated 200ms, or disabled entirely.

The three-state polarity select pin (SEL) chooses one of three possible polarity combinations for the adjustable input thresholds, as described in Table 1. An individual output is released when its corresponding ADJ input is valid (above threshold if configured for positive polarity, below threshold if configured for negative polarity).

Both input voltages (V_{ADJ1} and V_{ADJ2}) must be valid and V_{CC} above the UVLO threshold for longer than the reset timeout period before \overline{RST} is released. The LTC2919 asserts the reset output during power-up, power-down and brownout conditions on any of the voltage inputs.

Power-Up

The LTC2919 uses proprietary low voltage drive circuitry for the \overline{RST} , OUT1 and OUT2 pins which holds them low with V_{CC} as low as 200mV. This helps prevent indeterminate voltages from appearing on the outputs during power-up.

In applications where the low voltage pull-down capability is important, the supply to which the external pull-up resistor connects should be the same supply which powers the part. Using the same supply for both ensures that \overline{RST} , OUT1 and OUT2 never float above 200mV during power-up, as the pull-down ability of the pin will then increase as the required pull-down current to maintain a logic low increases.

Once V_{CC} passes the UVLO threshold, polarity selection and timer initialization will occur. If the monitored ADJ input is valid, the corresponding OUT will be released. When both ADJ1 and ADJ2 are valid, the appropriate timeout delay will begin, after which \overline{RST} will be released.

Power-Down

On power-down, once V_{CC} drops below the UVLO threshold or either V_{ADJ} becomes invalid, \overline{RST} asserts logic low. V_{CC} of at least 0.5V guarantees a logic low of 0.15V at \overline{RST} .

Shunt Regulator

The LTC2919 contains an internal 6.5V shunt regulator on the V_{CC} pin to allow operation from a high voltage supply. To operate the part from a supply higher than 6V, the V_{CC} pin must have a current-limiting series resistor, R_{CC} , to the supply. This resistor should be sized according to the following equation:

$$\frac{V_{S(MAX)} - 6.2V}{10mA} \leq R_{CC} \leq \frac{V_{S(MIN)} - 6.8V}{200\mu A + I_{REF}}$$

where $V_{S(MIN)}$ and $V_{S(MAX)}$ are the operating minimum and maximum of the supply, and I_{REF} is the maximum current the user expects to draw from the reference output.

As an example, consider operation from an automobile battery which might dip as low as 10V or spike to 60V. Assume that the user will be drawing 100 μ A from the reference. We must then pick a resistance between 5.4k and 10.7k.

When the V_{CC} pin is connected to a low impedance supply, it is important that the supply voltage never exceed 6V, or the shunt regulator may begin to draw large currents. Some supplies may have a nominal value sufficiently close to the shunt regulation voltage to prevent sizing of the resistor according to the above equation. For such supplies, a 470 Ω series resistor may be used.

Adjust Polarity Selection

The external connection of the SEL pin selects the polarities of the LTC2919 adjustable inputs. SEL may be connected to GND, connected to V_{CC} or left unconnected during normal operation. When left unconnected, the maximum leakage allowable from the pin is $\pm 5\mu$ A. Table 1 shows the three possible selections of polarity based on SEL connection.

Table 1. Voltage Threshold Selection

ADJ1 INPUT	ADJ2 INPUT	SEL
Positive Polarity (+) UV or (-) OV	Positive Polarity (+) UV or (-) OV	V_{CC}
Positive Polarity (+) UV or (-) OV	Negative Polarity (-) UV or (+) OV	Open
Negative Polarity (-) UV or (+) OV	Negative Polarity (-) UV or (+) OV	Ground

Note: Open = open circuit or driven by a three-state buffer in high impedance state with leakage current less than 5 μ A.

APPLICATIONS INFORMATION

If the user's application requires, the SEL pin may be driven using a three-state buffer which satisfies the V_{IL} , V_{IH} and leakage conditions of this three-state input pin.

If the state of the SEL pin configures a given input as "negative polarity," the voltage at that ADJ pin must be below the trip point (0.5V nominal), or the corresponding OUT and \overline{RST} output will be pulled low. Conversely, if a given input is configured as "positive polarity," the ADJ pin voltage must be above the trip point or the corresponding OUT and \overline{RST} will assert low.

Thus, a "negative polarity" input may be used to determine whether a monitored negative voltage is smaller in absolute value than it should be ($-UV$), or a monitored positive voltage is larger than it should be ($+OV$). The

opposite is true for a "positive polarity" input ($-OV$ or $+UV$). These polarity definitions are also shown in Table 1. For purposes of this data sheet, a negative voltage is considered "undervoltage" if it is closer to ground than it should be (e.g., $-4.3V$ for a $-5V$ supply).

Proper configuration of the SEL pin and setting of the trip-points via external resistors allows for any two fault conditions to be detected. For example, the LTC2919 may monitor two supplies (positive, negative or one of each) for UV or for OV (or one UV and one OV). It may also monitor a single supply (positive or negative) for both UV and OV. Table 2a and Table 2b show example configurations for monitoring possible combinations of fault condition and supply polarity.

Table 2a. Possible Combinations of Supply Monitoring. For Example Purposes, All Supplies are Monitored at 5% Tolerance and Connections are Shown Only for ADJ1, ADJ2, REF, SEL, OUT1 and OUT2. Output Pull-up Resistors are Omitted for Clarity.

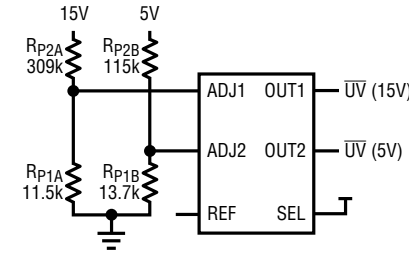
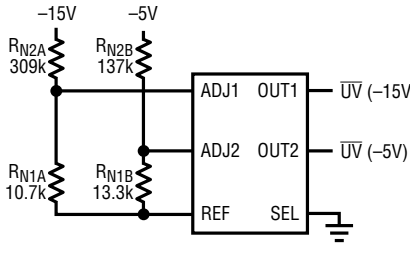
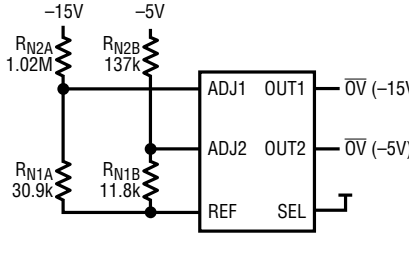
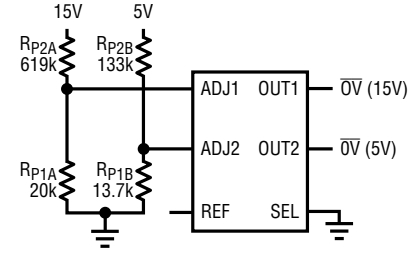
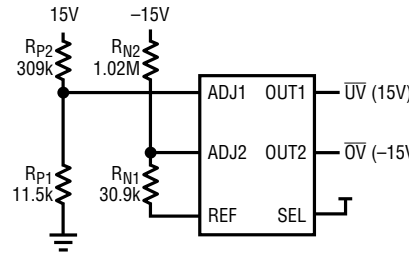
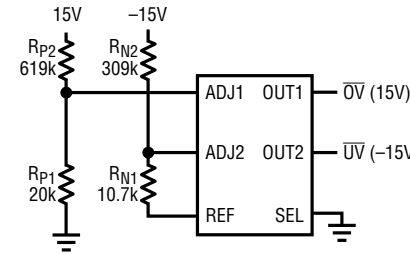
SEL = V _{CC}	SEL = GND
 <p style="text-align: center;">2 Positive UV</p>	 <p style="text-align: center;">2 Negative UV</p>
 <p style="text-align: center;">2 Negative OV</p>	 <p style="text-align: center;">2 Positive OV</p>
 <p style="text-align: center;">1 Positive UV, 1 Negative OV</p>	 <p style="text-align: center;">1 Positive OV, 1 Negative UV</p>

APPLICATIONS INFORMATION

Table 2b. Possible Combinations of Supply Monitoring. For Example Purposes, All Supplies are Monitored at 5% Tolerance and Connections are Shown Only for ADJ1, ADJ2, REF, SEL, OUT1 and OUT2. Output Pull-up Resistors are Omitted for Clarity.

SEL OPEN

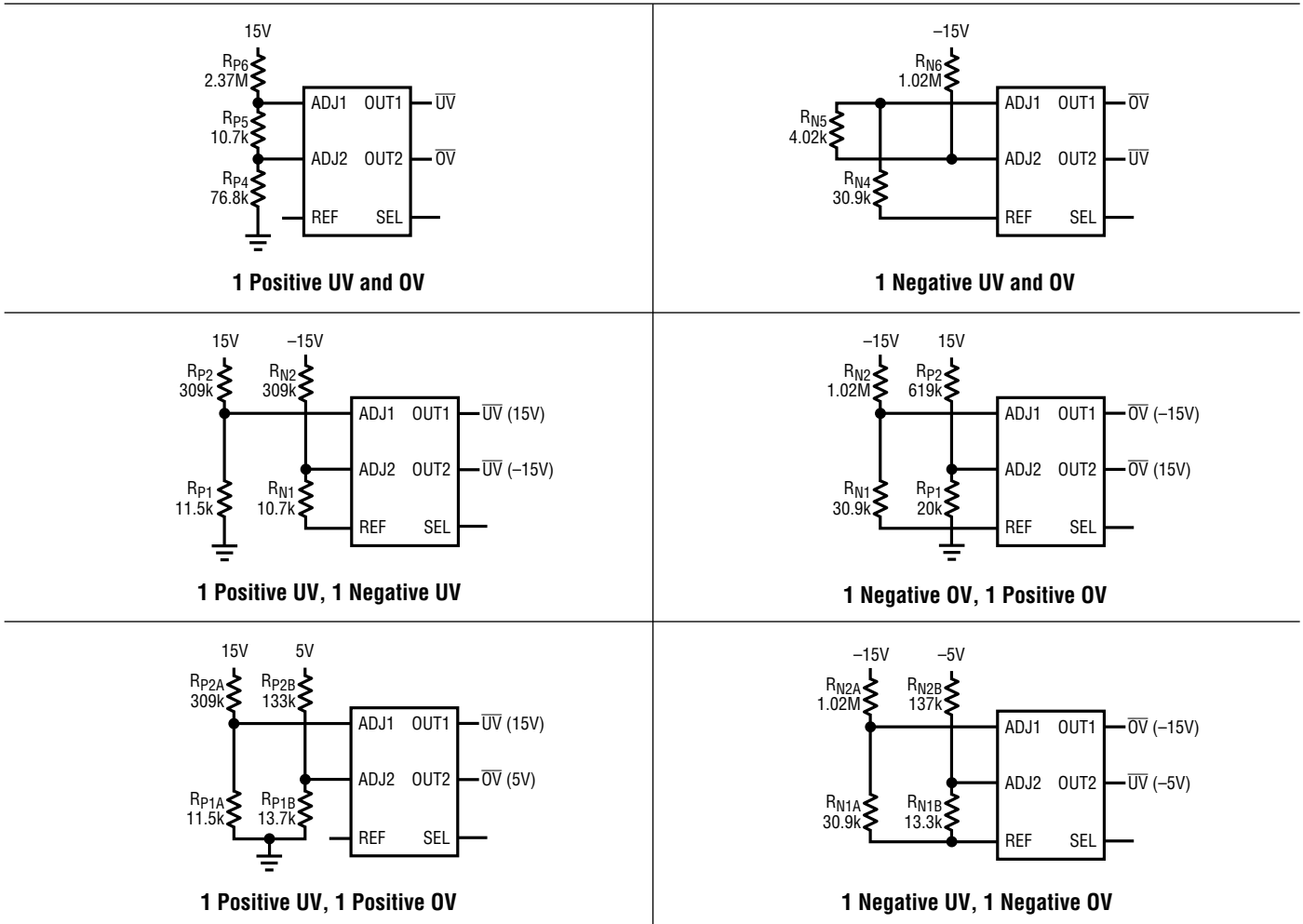

Adjust Input Trip Point

The trip threshold for the supplies monitored by the adjustable inputs is set with an external resistor divider, allowing the user complete control over the trip point. Selection of this trip voltage is crucial to the monitoring of the system.

Any power supply has some tolerance band within which it is expected to operate (e.g., $5V \pm 10\%$). It is generally undesirable that a supervisor issue a reset when the power supply is inside this tolerance band. Such a “nuisance” reset reduces reliability by preventing the system from functioning under normal conditions.

To prevent nuisance resets, the supervisor threshold must be guaranteed to lie outside the power supply tolerance band. To ensure that the threshold lies outside the power supply tolerance range, the nominal threshold must lie outside that range by the monitor’s accuracy specification.

All three of the LTC2919 inputs (ADJ1, ADJ2, V_{CC} UVLO) have the same maximum threshold accuracy of $\pm 1.5\%$ of the programmed nominal input voltage (over the full operating temperature range). Therefore, using the LTC2919, the typical 10% UV threshold is at 11.5% below the nominal input voltage level. For a 5V input, the threshold is nominally 4.425V. With $\pm 1.5\%$ accuracy, the trip

APPLICATIONS INFORMATION

threshold range is $4.425V \pm 75mV$ over temperature (i.e., 10% to 13% below 5V). The monitored system must thus operate reliably down to 4.35V or 13% below 5V over temperature.

The above discussion is concerned only with the DC value of the monitored supply. Real supplies also have relatively high frequency variations from sources such as load transients, noise and pickup.

The LTC2919 uses two techniques to combat spurious outputs toggling from high frequency variation. First, the timeout period helps prevent high frequency variation whose frequency is above $1/t_{RST}$ from appearing at the \overline{RST} output. Second, the propagation delay versus overdrive function filters short glitches before the OUT1, OUT2 toggling or \overline{RST} pulling low.

When an ADJ becomes invalid, the corresponding OUT and \overline{RST} pin assert low. When the supply recovers past the valid threshold, the reset timer starts (assuming it is not disabled) and \overline{RST} does not go high until it finishes. If the supply becomes invalid any time during the timeout period, the timer resets and starts fresh when the supply next becomes valid.

To reduce sensitivity of short glitches from toggling the output pins, the comparator outputs go through a low-pass filter before triggering the output logic. Any transient at the input of a comparator needs to be of sufficient magnitude and duration to pass the filter before it can change the monitor state.

The combination of the reset timeout and comparator filtering prevents spurious changes in the output state without sacrificing threshold accuracy. If further supply glitch immunity is needed, the user may place an external capacitor from the ADJ input to ground. The resultant RC lowpass filter with the resistor divider will further reject high frequency components of the supply, at the cost of slowing the monitor's response to fault conditions.

A common solution to the problem of spurious reset is to introduce hysteresis around the nominal threshold. However, this hysteresis degrades the effective accuracy of the monitor and increases the range over which the system must operate. The LTC2919 therefore does not have hysteresis, except in comparator mode (by tying

TMR pin to V_{CC}). If hysteresis is desired in other modes, it may be added externally. See 48V Telecom UV/OV with Hysteresis Applications on page 14 for an example.

Selecting External Resistors

In a typical positive supply monitoring application, the ADJx pin connects to a tap point on an external resistive divider between a positive voltage being monitored and ground, as shown in Figure 1.

When monitoring a negative supply, the ADJx pin connects to a tap point on a resistive divider between the negative voltage being monitored and the buffered reference (REF), as shown in Figure 2.

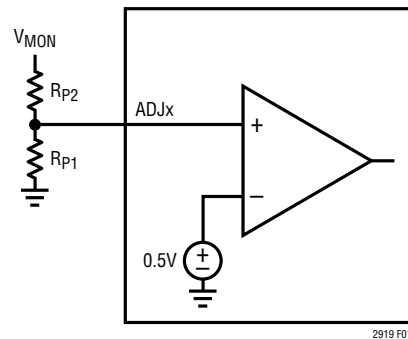

Figure 1. Setting Positive Supply Trip Point

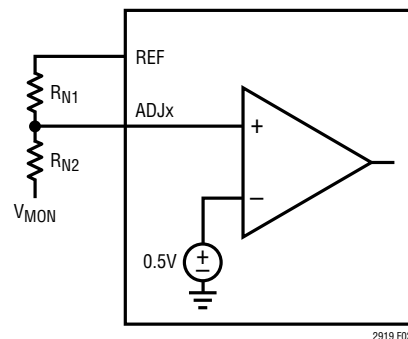

Figure 2. Setting Negative Supply Trip Point

Normally the user will select a desired trip voltage based on their supply and acceptable tolerances, and a value of R_{N1} or R_{P1} based on current draw. Current used by the resistive divider will be approximately:

$$I = \frac{0.5V}{R_{P1}} \text{ OR } = \frac{0.5V}{R_{N1}}$$

APPLICATIONS INFORMATION

To minimize errors arising from ADJ input bias and to minimize loading on REF choose resistor R_{P1} (for positive supply monitoring) or R_{N1} (for negative supply monitoring) in the range of 5k to 100k.

For a positive-monitoring application, R_{P2} is then chosen by:

$$R_{P2} = R_{P1}(2V_{TRIP} - 1)$$

For a negative-monitoring application:

$$R_{N2} = R_{N1}(1 - 2V_{TRIP})$$

Note that the value V_{TRIP} should be negative for a negative application.

The LTC2919 can also be used to monitor a single supply for both UV and OV. This may be accomplished with three resistors, instead of the four required for two independent supplies. Configurations are shown in Figure 3 and Figure 4. R_{P4} or R_{N4} may be chosen as is R_{P1} or R_{N1} above.

For a given R_{P4} , monitoring a positive supply:

$$R_{P5} = R_{P4} \frac{V_{OV} - V_{UV}}{V_{UV}}$$

$$R_{P6} = R_{P4} (2V_{UV} - 1) \frac{V_{OV}}{V_{UV}}$$

For monitoring a negative supply with a given R_{N4} :

$$R_{N5} = R_{N4} \frac{V_{UV} - V_{OV}}{1 - V_{UV}}$$

$$R_{N6} = R_{N4} (1 - 2V_{UV}) \frac{1 - V_{OV}}{1 - V_{UV}}$$

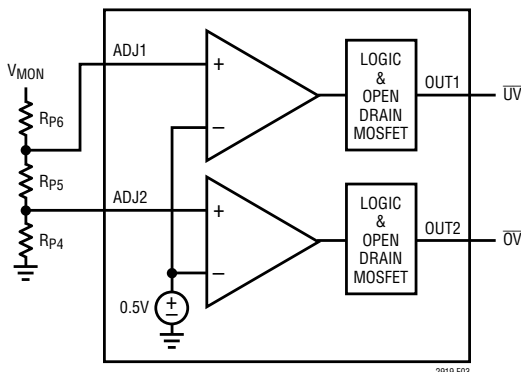

Figure 3. Setting UV and OV Trip Point for a Positive Supply

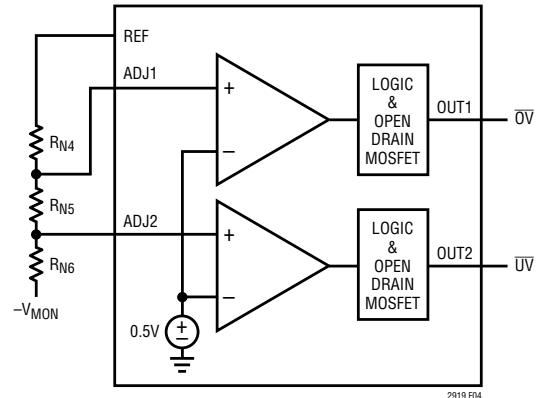

Figure 4. Setting UV and OV Trip Point for a Negative Supply

For example, consider monitoring a $-5V$ supply at $\pm 10\%$. For this supply application: $V_{OV} = -5.575V$ and $V_{UV} = -4.425V$. Suppose we wish to consume about $5\mu A$ in the divider, so $R_{N4} = 100k$. We then find $R_{N5} = 21.0k$, $R_{N6} = 1.18M$ (nearest 1% standard values have been chosen).

V_{CC} Monitoring/UVLO

The LTC2919 contains an accurate third -10% undervoltage monitor on the V_{CC} pin. This monitor is fixed at a nominal 11.5% below the V_{CC} specified in the part number. The standard part (LTC2919-2.5) is configured to monitor a 2.5V supply (UVLO threshold of 2.213V), but versions to monitor 3.3V and 5.0V (UVLO of 2.921V and 4.425V, respectively) are available.

For applications that do not need V_{CC} monitoring, the 2.5V version should be used, and the UVLO will simply guarantee that the V_{CC} is above the minimum required for proper threshold and timer accuracy before the timeout begins.

Setting the Reset Timeout

\overline{RST} goes high after a reset timeout period set by the TMR pin when the V_{CC} and ADJ inputs are valid. This reset timeout may be configured in one of three ways: internal 200ms, programmed by external capacitor and no timeout (comparator mode).

In externally-controlled mode, the TMR pin is connected by a capacitor to ground. The value of that capacitor allows for selection of a timeout ranging from about $400\mu s$ to 9 seconds. See the following section for details.

APPLICATIONS INFORMATION

If the user wishes to avoid having an external capacitor, the TMR pin should be tied to ground, switching the part to an internal 200ms timer.

If the user requires a shorter timeout than 400 μ s, or wishes to perform application-specific processing of the reset output, the part may be put in comparator mode by tying the TMR pin to V_{CC} . In comparator mode, the timer is bypassed and comparator outputs go straight to the reset output.

The current required to hold TMR at ground or V_{CC} is about 2.2 μ A. To force the pin from the floating state to ground or V_{CC} may require as much as 100 μ A during the transition.

When the part is in comparator mode, one of the two means of preventing false reset has been removed, so a small amount of one-sided hysteresis is added to the inputs to prevent oscillation as the monitored voltage passes through the threshold. This hysteresis is such that the valid-to-invalid transition threshold is unchanged, but the invalid-to-valid threshold is moved by about 0.7%. Thus, when the ADJ input polarity is positive, the threshold voltage is 500mV nominal when the input is above 500mV. As soon as the input drops below 500mV, the threshold moves up to 503.5mV nominal. Conversely, when configured as a negative-polarity input, the threshold is 500mV when the input is below 500mV, and switches to 496.5mV when the input goes above 500mV.

The comparator mode feature is enabled by directly shorting the TMR pin to the V_{CC} pin. Connecting the pin to any other voltage may have unpredictable results.

Selecting the Reset Timing Capacitor

Connecting a capacitor, C_{TMR} , between the TMR pin and ground sets the reset timeout, t_{RST} . The following formula approximates the value of capacitor needed for a particular timeout:

$$C_{TMR} = t_{RST} \cdot 110 \text{ [pF/ms]}$$

Leaving the TMR pin open with no external capacitor generates a reset timeout of approximately 400 μ s.

Maximum length of the reset timeout is limited by the ability of the part to charge a large capacitor on start-up. Initially, with a large (discharged) capacitor on the TMR pin, the part will assume it is in internal timer mode (since the pin voltage will be at ground). If the 2.2 μ A flowing out of the TMR pin does not charge the capacitor to the ground-sense threshold within the first 200ms after supplies become good, the internal timer cycle will complete and \overline{RST} will go high too soon.

This imposes a practical limit of 1 μ F (9 second timeout) if the length of timeout during power-up needs to be longer than 200ms. If the power-up timeout is not important, larger capacitors may be used, subject to the limitation that the capacitor leakage current must not exceed 500nA, or the function of the timer will be impaired.

Output Pins Characteristics

The DC characteristics of the OUT1, OUT2 and \overline{RST} pull-down strength are shown in the Typical Performance Characteristics section. OUT1, OUT2 and \overline{RST} are open-drain pins and thus require external pull-up resistors to the logic supply. They may be pulled above V_{CC} , providing the absolute maximum rating of the pin are observed.

As noted in the discussion of power up and power down, the circuits that drive OUT1, OUT2 and \overline{RST} are powered by V_{CC} . During a fault condition, V_{CC} of at least 0.5V guarantees a V_{OL} of 0.15V.

The open-drain nature of the \overline{RST} pin allows for wired-OR connection of several LTC2919s to monitor more than two supplies (see Typical Applications). Other logic with open-drain outputs may also connect to the \overline{RST} line, allowing other logic-determined conditions to issue a reset.

TYPICAL APPLICATIONS

48V Telecom UV/OV Monitor with Hysteresis

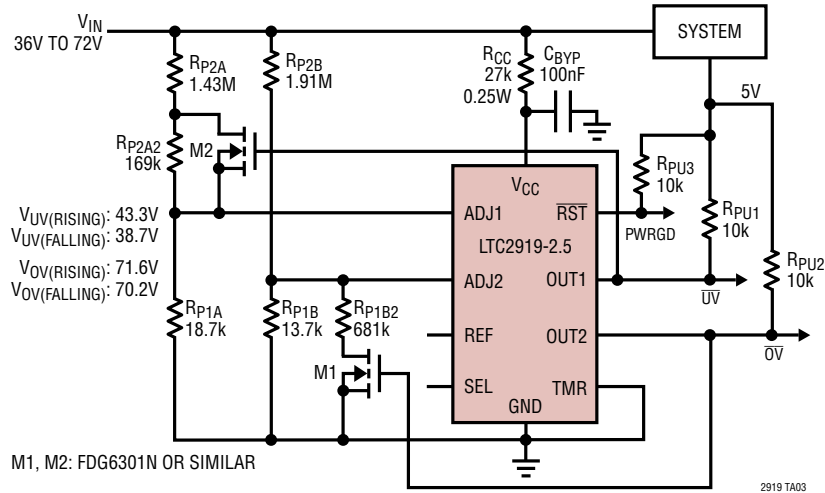

±12V UV Monitor Powered from 12V, 20ms Timeout (1.8V Logic Out)

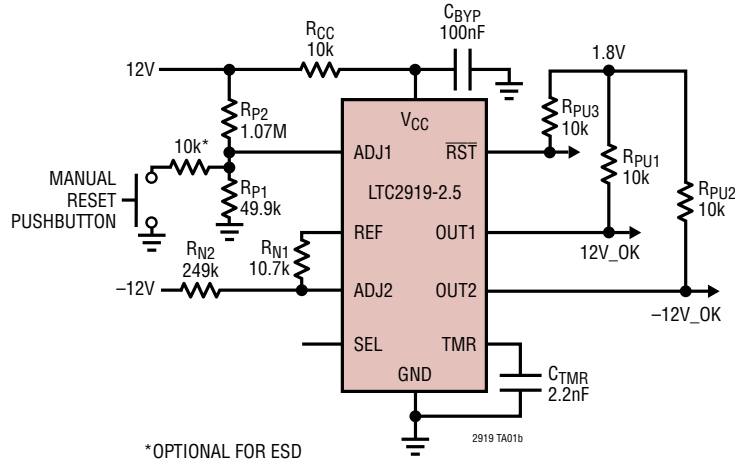

PACKAGE DESCRIPTION

**MS Package
10-Lead Plastic MSOP**

(Reference LTC DWG # 05-08-1661 Rev F)

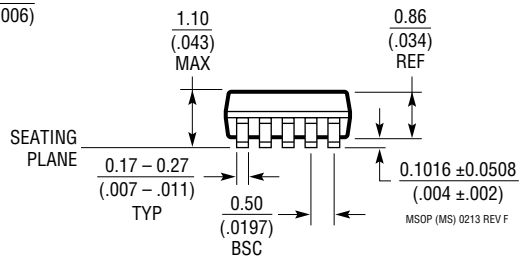
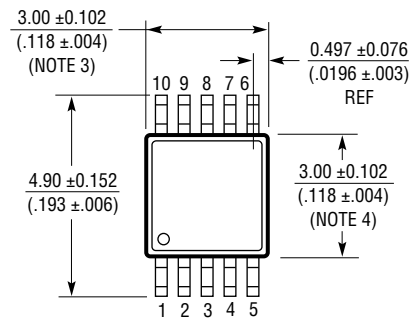
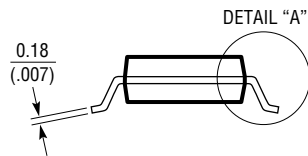
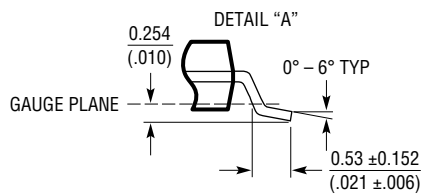
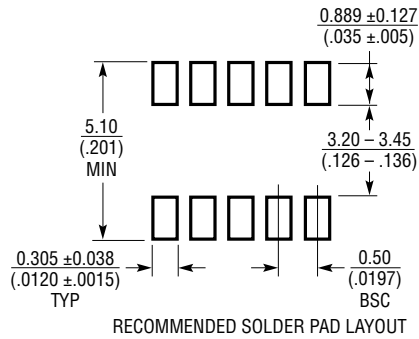

NOTE:

1. DIMENSIONS IN MILLIMETER/(INCH)
2. DRAWING NOT TO SCALE
3. DIMENSION DOES NOT INCLUDE MOLD FLASH, PROTRUSIONS OR GATE BURRS.
MOLD FLASH, PROTRUSIONS OR GATE BURRS SHALL NOT EXCEED 0.152mm (.006") PER SIDE
4. DIMENSION DOES NOT INCLUDE INTERLEAD FLASH OR PROTRUSIONS.
INTERLEAD FLASH OR PROTRUSIONS SHALL NOT EXCEED 0.152mm (.006") PER SIDE
5. LEAD COPLANARITY (BOTTOM OF LEADS AFTER FORMING) SHALL BE 0.102mm (.004") MAX

REVISION HISTORY (Revision history begins at Rev B)

REV	DATE	DESCRIPTION	PAGE NUMBER
A	08/19	Added AEC-Q100.	1, 3

TYPICAL APPLICATION

Powered from 12V, +5V_{OUT} is Sequenced to Start-up First, Followed by -5V_{OUT}, with ±5V UV Monitor, 200ms Timeout

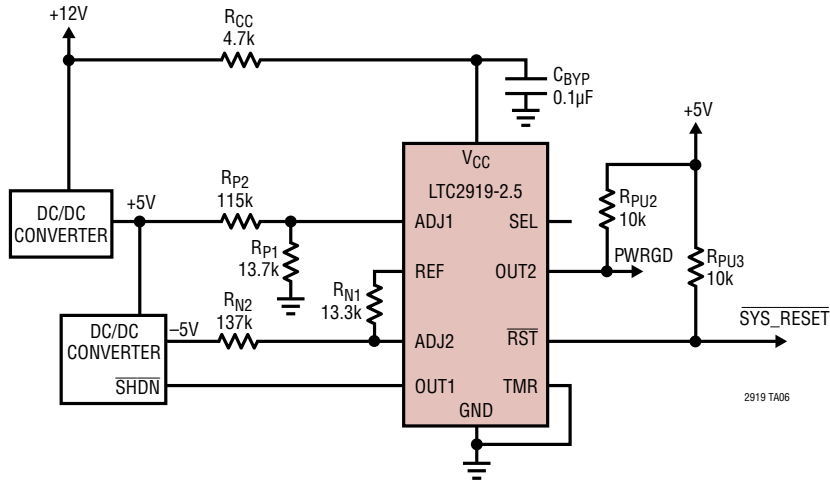



RELATED PARTS

PART NUMBER	DESCRIPTION	COMMENTS
LTC1326/LTC1326-2.5	Micropower Precision Triple Supply Monitor for 5V/2.5V, 3.3V and ADJ	4.725V, 3.118V, 1V Threshold ($\pm 0.75\%$)
LTC1536	Precision Triple Supply Monitor for PCI Applications	Meets PCI t _{FAIL} Timing Specifications
LTC1540	Nanopower Comparator with Reference	Adjustable Hysteresis
LTC1726-2.5/LTC1726-5	Micropower Triple Supply Monitor for 2.5V/5V, 3.3V and ADJ	Adjustable Reset and Watchdog Time-Outs
LTC1727/LTC1728	Micropower Triple Supply Monitor with Open-Drain Reset	Individual Monitor Outputs in MSOP/5-Lead SOT-23
LTC1985-1.8	Micropower Triple Supply Monitor with Push-Pull Reset Output	5-Lead SOT-23 Package
LTC2900	Programmable Quad Supply Monitor	Adjustable Reset, 10-Lead MSOP and 3mm × 3mm 10-Lead DFN Package
LTC2901	Programmable Quad Supply Monitor	Adjustable Reset and Watchdog Timer, 16-Lead SSOP Package
LTC2902	Programmable Quad Supply Monitor	Adjustable Reset and Tolerance, 16-Lead SSOP Package, Margining Functions
LTC2903	Precision Quad Supply Monitor	6-Lead SOT-23 Package, Ultralow Voltage Reset
LTC2904/LTC2905	3-State Programmable Precision Dual Supply Monitor	Adjustable Tolerance and Reset Timer, 8-Lead SOT-23 Package
LTC2906/LTC2907	Precision Dual Supply Monitor 1-Selectable and 1 Adjustable	Separate V _{CC} Pin, RST/ $\overline{\text{RST}}$ Outputs/Adjustable Reset Timer
LTC2908	Precision Six Supply Monitor (Four Fixed and 2 Adjustable)	8-Lead SOT-23 and DFN Packages
LTC2909	Precision, Dual Input UV, OV and Negative Voltage Monitor	8-Lead SOT-23 and DFN Packages
LTC2912-LTC2914	Single/Dual/Quad UV and OV Voltage Monitors	Separate V _{CC} Pin, Adjustable Reset Timer, H-Grade Temperature Range
LTC2915-LTC2918	Single Voltage Monitor with 27 Unique Thresholds	Manual Reset, Watchdog, TSOT-8/MSOP-10 and 3mm × 2mm DFN Package, H-Grade Temperature Range
LT6700	Micropower, Low Voltage, Dual Comparator with 400mV Reference	6-Lead SOT-23 Package

Rev. A

Looking for pricing, stock, or lifecycle information?

Click below to explore more details on WIN SOURCE:

-  [View LTC2919HMS-2.5#PBF on WIN SOURCE](#)
-  [Analog Devices Inc. Information](#)

Optimize Your Supply Chain with WIN SOURCE Solutions

-  Global Sourcing Solution
-  Obsolete Management
-  Cost Control Management
-  Shortage Management
-  Alternative Solution
-  Excess Inventory Management