



THE DATASHEET OF BM2P016T-Z



AC/DC Drivers

PWM type DC/DC converter IC Included 650V MOSFET

BM2P016T

•General

The PWM type DC/DC converter (BM2P016T) for AC/DC provides an optimum system for all products that include an electrical outlet.

BM2P016T supports both isolated and non-isolated devices, enabling simpler design of various types of low-power electrical converters.

BM2P016T builds in a HV starter circuit that tolerates 650V, and it contributes to low-power consumption. With current detection resistors for switching as external devices, a higher degree of design freedom is achieved. Since current mode control is utilized, current is restricted in each cycle and excellent performance is demonstrated in bandwidth and transient response. The switching frequency is 65 kHz. At light load, the switching frequency is reduced and high efficiency is achieved. A frequency hopping function is also on chip, which contributes to low EMI. We can design easily, because BM2P016T includes the switching MOSFET.

•Basic specifications

- Operating Power Supply Voltage Range
VCC: 8.9V to 26.0V
DRAIN: to 650V
- Operating Current:
Normal Mode: 0.950mA (Typ.)
Burst Mode: 0.300mA (Typ.)
- Oscillation Frequency: 65kHz(Typ.)
- Operating Temperature: - 40 °C to +105 °C
- MOSFET ON Resistance: 1.4Ω (Typ.)

•Features

- PWM frequency : 65kHz
- PWM current mode method
- Frequency hopping function
- Burst operation at light load
- Frequency reduction function
- Built-in 650V start circuit
- Built-in 650V switching MOSFET
- VCC pin under voltage protection
- VCC pin over voltage protection
- SOURCE pin Open protection
- SOURCE pin Short protection
- SOURCE pin Leading-Edge-Blanking function
- Per-cycle over current protection circuit
- AC Correction function of over current limiter
- Soft start function
- Secondary over current protection circuit

•Package

TO220-7M 10.0mm×25.4mm×4.6mm
(Typ.) (Typ.) (Max.)

•Applications

AC adapters and household appliances (vacuum cleaners, humidifiers, air cleaners, air conditioners, IH cooking heaters, rice cookers, etc.)

•Application circuit

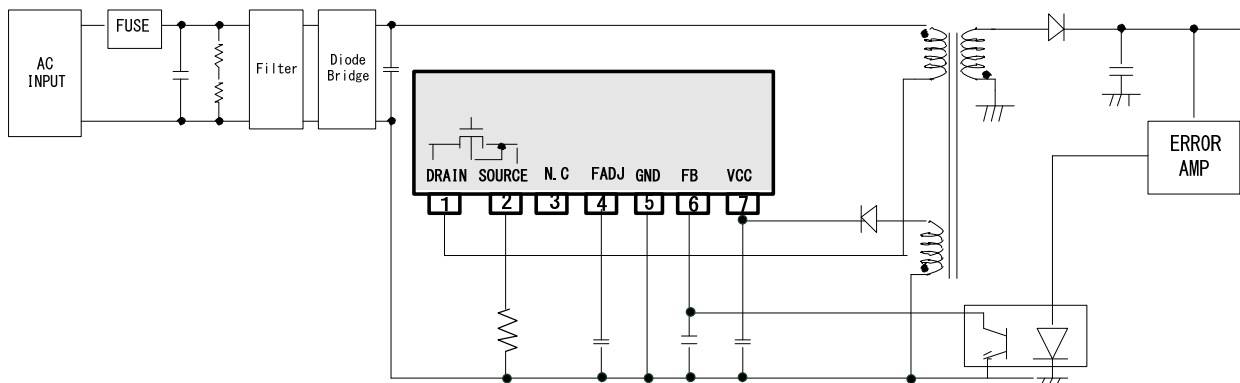

Figure 1. Application Circuit

●Absolute Maximum Ratings (Ta=25°C)

Parameter	Symbol	Rating	Unit	Conditions
Maximum applied voltage 1	V_{max1}	-0.3 to 32.0	V	VCC
Maximum applied voltage 2	V_{max2}	-0.3 to 6.5	V	SOURCE, FB, FADJ
Maximum applied voltage 3	V_{max3}	650	V	DRAIN
Drain current pulse	I_{DP}	10.40	A	$P_w=10\mu s$, Duty cycle=1%
Allowable dissipation	P_d	1.50	W	
Operating temperature range	T_{opr}	-40 to +105	°C	
MAX junction temperature	T_{jmax}	150	°C	
Storage temperature range	T_{str}	-55 to +150	°C	

(Note1) Derate by 12mW/°C when operating above Ta = 25°C when mounted

Caution: Operating the IC over the absolute maximum ratings may damage the IC. The damage can either be a short circuit between pins or an open circuit between pins and the internal circuitry. Therefore, it is important to consider circuit protection measures, such as adding a fuse, in case the IC is operated over the absolute maximum ratings.

●Operating Conditions (Ta=25°C)

Parameter	Symbol	Rating	Unit	Conditions
Power supply voltage range 1	V_{CC}	8.9 to 26.0	V	VCC pin voltage
Power supply voltage range 2	V_{DRAIN}	650	V	DRAIN pin voltage

●Electrical Characteristics of MOSFET part (Unless otherwise noted, Ta = 25°C, VCC = 15 V)

Parameter	Symbol	Specifications			Unit	Conditions
		Min	Typ	Max		
[MOSFET Block]						
Between drain and Source voltage	$V_{(BR)DDS}$	650	-	-	V	$I_D=1mA / V_{GS}=0V$
Drain leak current	I_{DSS}	-	-	100	uA	$V_{DS}=650V / V_{GS}=0V$
On resistance	$R_{DS(ON)}$	-	1.4	2.0	Ω	$I_D=0.25A / V_{GS}=10V$

●Electrical Characteristics (unless otherwise noted, Ta = 25°C, VCC = 15 V)

Parameter	Symbol	Specifications			Unit	Conditions
		Min	Typ	Max		
[Circuit Current]						
Circuit current (ON) 1	I _{ON1}	700	950	1200	μA	FB=2.0(at pulse operation)
Circuit current (ON) 2	I _{ON2}	200	300	400	μA	FB=0.0V(at burst operation)
[VCC Protection Function]						
VCC UVLO voltage 1	V _{UVLO1}	12.50	13.50	14.50	V	VCC rise
VCC UVLO voltage 2	V _{UVLO2}	7.50	8.20	8.90	V	VCC fall
VCC UVLO hysteresis	V _{UVLO3}	-	5.30	-		V _{UVLO3} = V _{UVLO1} - V _{UVLO2}
VCC OVP voltage 1	V _{OVP1}	26.0	27.5	29.0	V	VCC rise
VCC OVP voltage 2	V _{OVP2}	22.0	23.5	25.0	V	VCC fall
VCC OVP hysteresis	V _{OVP3}	-	4.0	-	V	V _{OVP3} = V _{OVP1} - V _{OVP2}
VCC recharge start voltage	V _{CHG1}	7.70	8.70	9.70	V	
VCC recharge stop voltage	V _{CHG2}	12.00	13.00	14.00	V	
Latch mask time	T _{LATCH}	50	100	150	us	
Thermal shut down temperature1	T _{SD1}	120	145	170	°C	Control IC, temp rise
Thermal shut down temperature2	T _{SD2}	90	115	140	°C	Control IC, temp fall
[PWM Type DCDC Driver Block]						
Oscillation frequency 1	F _{SW1}	60	65	70	KHz	FB=2.00V
Oscillation frequency 2	F _{SW2}	20	25	30	KHz	FB=0.30V
Frequency hopping width 1	F _{DEL1}	-	0.833	-	KHz	FB=2.00V
Hopping fluctuation frequency	F _{CH}	75	125	175	Hz	
FADJ source current	I _{BST}	0.80	1.00	1.20	uA	FADJ=0.00V
FADJ comparator voltage	V _{BST}	1.13	1.20	1.27	V	
FADJ max burst frequency	F _{BST}	-	0.833	-	KHz	CFADJ=1000pF
Soft start time 1	T _{SS1}	0.30	0.50	0.70	ms	
Soft start time 2	T _{SS2}	0.60	1.00	1.40	ms	
Soft start time 3	T _{SS3}	1.20	2.00	2.80	ms	
Soft start time 4	T _{SS4}	4.80	8.00	11.20	ms	
Maximum duty	D _{max}	68.0	75.0	82.0	%	
Minimum ON time	T _{min}	150	400	650	ns	
FB pin pull-up resistance	R _{FB}	23	30	37	kΩ	
ΔFB / ΔSOURCE gain	Gain	3.00	4.00	7.00	V/V	
FB burst voltage 1	V _{BST1}	0.220	0.280	0.340	V	FB fall
FB burst voltage 2	V _{BST2}	0.260	0.320	0.380	V	FB rise
FB burst hysteresis	V _{BST3}	-	0.040	-	V	V _{BST3} = V _{BST2} - V _{BST1}
FB voltage of starting frequency reduction mode	V _{DLT}	1.100	1.250	1.400	V	
FB OLP voltage 1a	V _{FOLP1A}	2.60	2.80	3.00	V	Overload is detected (FB rise)
FB OLP voltage 1b	V _{FOLP1B}	2.40	2.60	2.80	V	Overload is detected (FB fall)
FB OLP ON time	T _{FOLP1}	80	128	176	ms	
FB OLP OFF time	T _{FOLP2}	332	512	692	ms	
[Over Current Detection Block]						
Over-current detection voltage	V _{SOURCE}	0.375	0.400	0.425	V	Ton=0us
Over-current detection voltage SS1	V _{S_SS1}	0.050	0.100	0.150	V	0[ms] to Tss1 [ms]
Over-current detection voltage SS2	V _{S_SS2}	0.080	0.150	0.220	V	TSS1 [ms] to TSS2 [ms]
Over-current detection voltage SS3	V _{S_SS3}	0.130	0.200	0.270	V	TSS2 [ms] to TSS3 [ms]
Over-current detection voltage SS4	V _{S_SS4}	0.230	0.300	0.370	V	TSS3 [ms] to TSS4 [ms]
Leading edge blanking time	T _{LEB}	(120)	250	(380)	ns	Design assurance
Over current detection AC voltage compensation factor	K _{SOURCE}	12	20	28	mV/us	
SOURCE pin short protection voltage	V _{SHT}	0.020	0.050	0.080	V	
SOURCE pin short protection time	T _{SOURCEST}	1.80	3.00	4.20	us	
[Circuit Current]						
Start current 1	I _{START1}	0.100	0.500	1.000	mA	VCC=0V
Start current 2	I _{START2}	1.000	3.000	6.000	mA	VCC=10V
OFF current	I _{START3}	-	10	20	uA	Inflow current from Drain pin after UVLO is released and when MOSFET is OFF
Start current switching voltage	V _{Sc}	0.800	1.500	2.100	V	

●Pin Descriptions

Table 1. Pin Description

NO.	Pin Name	I/O	Function	ESD Diode	
				VCC	GND
1	DRAIN	I/O	MOSFET DRAIN pin	-	-
2	SOURCE	I/O	MOSFET SOURCE pin	○	○
3	N.C.	-	-	-	-
4	FADJ	I	MAX Burst Frequency setting pin	○	○
5	GND	I/O	GND pin	○	-
6	FB	I	Feedback signal input pin	○	○
7	VCC	I	Power supply input pin	-	○

●I/O Equivalent Circuit Diagram

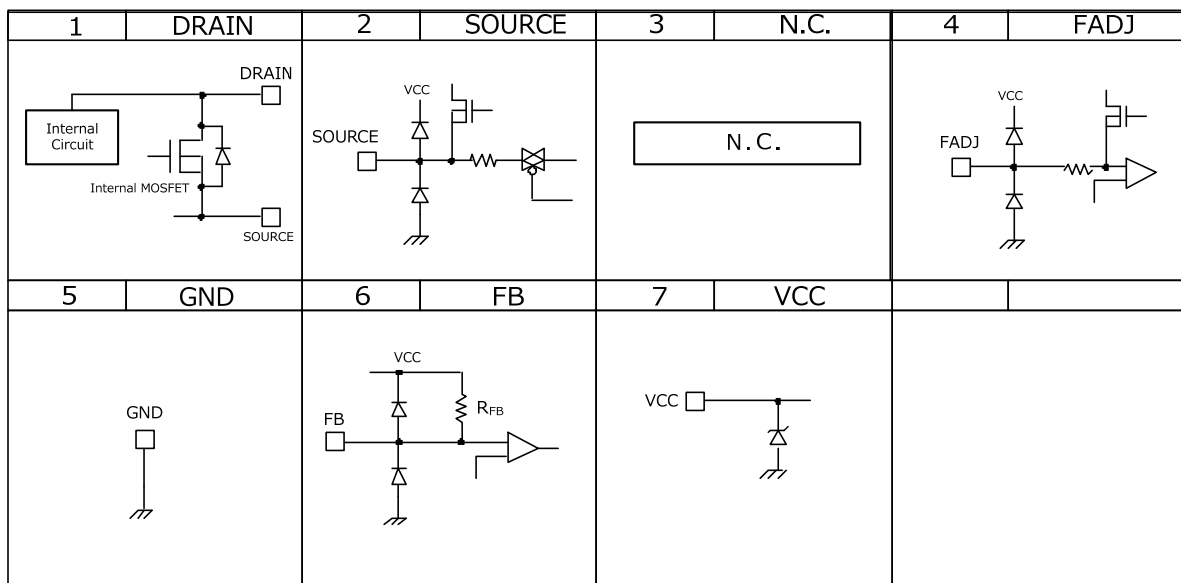

Figure 2. I/O Equivalent Circuit Diagram

●Block Description

(1) Start circuit

This IC has a built-in start circuit. It enables low standby mode electricity and high speed start. After start up, consumption power is determined by idling current I_{START3} (Typ=10uA) only. Reference values of starting time are shown in Figure 6. When $C_{VCC}=10\mu F$ it can start in less than 0.1 sec.

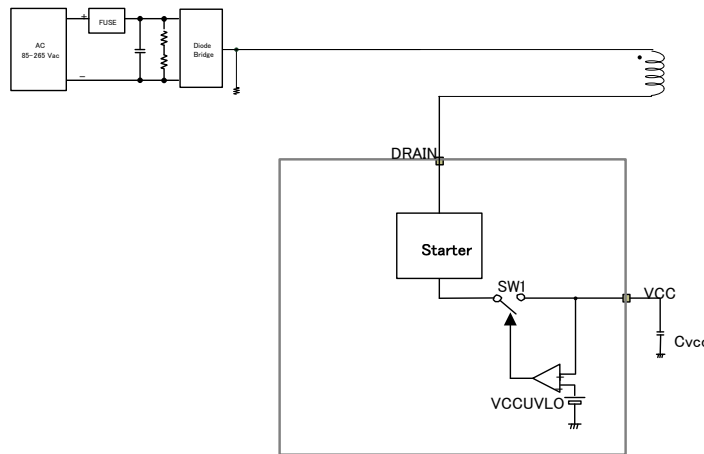

Figure 4. Block Diagram of Start Circuit

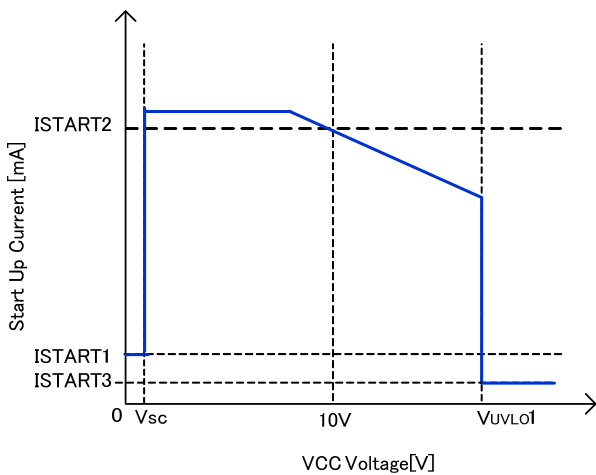

Figure 5. Start Current vs VCC Voltage

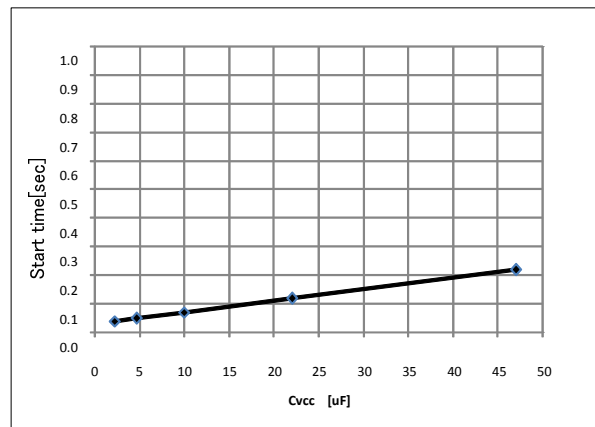

Figure 6. Start Time (reference value)

* Start current flows from the DRAIN pin

Ex) Consumption power of start circuit only when $V_{ac}=100V$
 $P_{VH} = 100V \cdot \sqrt{2} \cdot 10\mu A = 1.41mW$

Ex) Consumption power of start circuit only when $V_{ac}=240V$
 $P_{VH} = 240V \cdot \sqrt{2} \cdot 10\mu A = 3.38mW$

(2) Start sequences

(Soft start operation, light load operation, and auto recovery operation during overload protection)

Start sequences are shown in Figure 7. See the sections below for detailed descriptions.

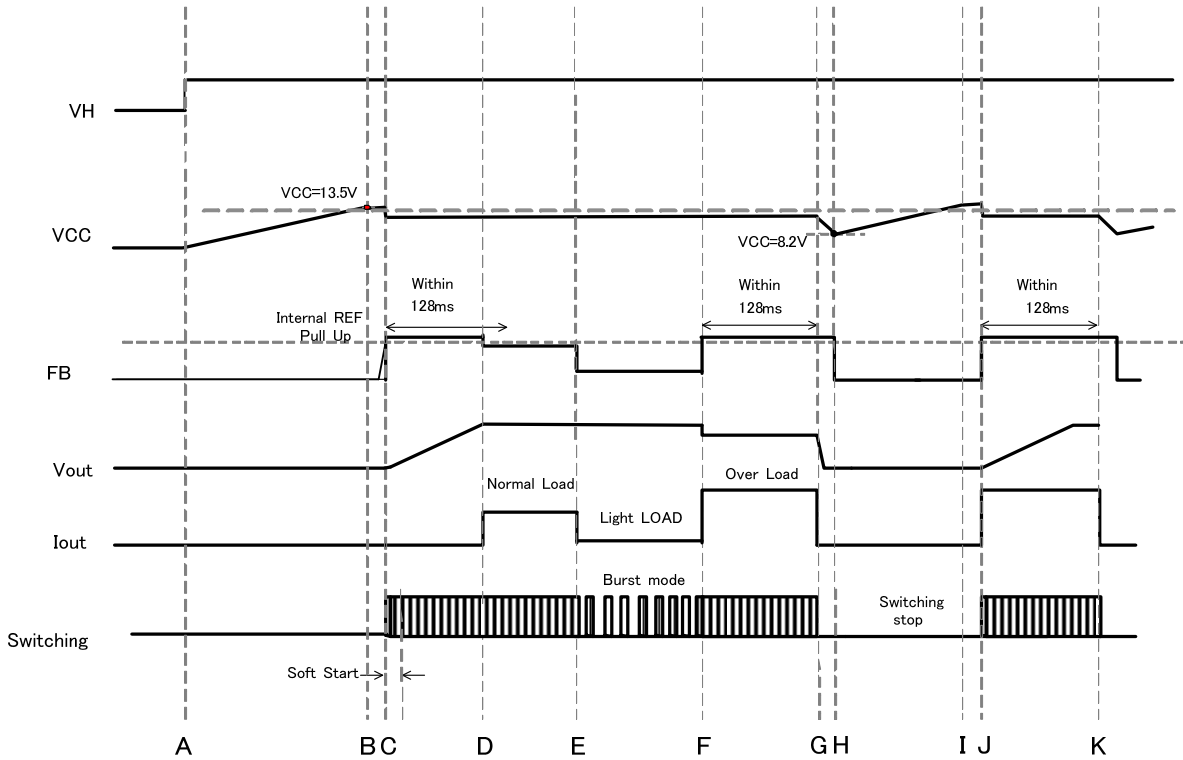

Figure 7. Start Sequences Timing Chart

- A: Input voltage V_H is applied.
- B: This IC starts operating when $V_{CC} > V_{UVLO1}$ (13.5V Typ).
Switching function starts when other protection functions are judged as normal.
When the secondary output voltage becomes constant, VCC pin current causes the VCC voltage to drop. As a result, IC should be set to start switching until $V_{CC} < V_{UVLO2}$ (8.2V Typ).
- C: With the soft start function, over current limit value is restricted to prevent any excessive rise in voltage or current.
- D: When the switching operation starts, V_{OUT} rises.
Once the output voltage starts, set the rated voltage within the T_{FOLP} period (128ms Typ).
- E: When there is a light load, it makes FB voltage $< V_{BST}$ (0.3V Typ). Burst operation is used to keep power consumption down. During burst operation, it operates at low-power consumption mode.
- F: When the FB pin Voltage $> V_{FOLP1A}$ (2.8V Typ), it overloads.
- G: When the FB pin voltage keeps V_{FOLP1A} (= 2.8V Typ) at or goes above T_{FOLP} (128ms Typ), the overload protection function is triggered and the switching stops. During the T_{FOLP} period (128ms Typ), if the FB pin voltage becomes $< V_{FOLP1B}$ even once, the IC's internal timer is reset.
- H: If the VCC voltage drops to $< V_{UVLO2}$ (7.7V Typ) or below, restart is executed.
- I: The IC's circuit current is reduced and the VCC pin value rises. (Same as B)
- J: Same as F
- K: Same as G

(3) VCC pin protection function

This IC has a built-in VCC low voltage protection function VCCUVLO (Under Voltage Lock Out), over voltage protection function VCCOVP (Over Voltage Protection), and a VCC recharge function that operates in case of a drop in VCC voltage. VCC charge function stabilizes the secondary output voltage, charged from high voltage lines by the start circuit when VCC voltage drops.

(3-1) VCC UVLO / VCC OVP function

VCCUVLO is an auto recovery comparator with voltage hysteresis. VCCOVP is auto restart type comparator.

VCCOVP operates in case of continuing VCC pin voltage $> V_{OVP}$ (Typ=27.5V).

This function has a built-in mask time T_{LATCH} (Typ=100us). Through this function, the IC is protected from pin generated surge, etc.

(3-2) VCC charge function

This IC has the recharge function.

VCC charge function operates once the VCC pin $> V_{UVLO1}$ and when the DC/DC operation starts. The VCC pin voltage then drops to $< V_{CHG1}$. At that time the VCC pin is charged from the DRAIN pin through the start circuit.

Through this operation, these series prevent failure.

VCC pin voltage rises until $VCC > V_{CHG2}$. The operation is shown in figure 8.

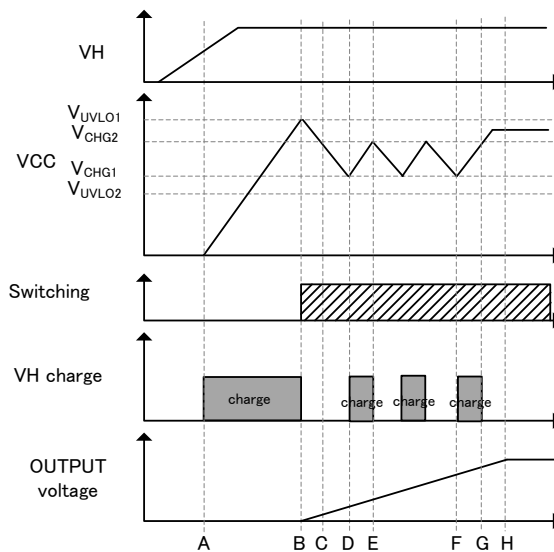

Figure 8. VCC Pin Charge Operation

- A: DRAIN pin voltage rises, charges VCC pin through the VCC charge function.
- B: $VCC > V_{UVLO1}$, VCC UVLO function releases, VCC charge function stops, DC/DC operation starts.
- C: When the DC/DC operation starts, the VCC voltage drops.
- D: $VCC < V_{CHG1}$, VCC recharge function operates.
- E: $VCC > V_{CHG2}$, VCC recharge function stops.
- F: $VCC < V_{CHG1}$, VCC recharge function operates.
- G: $VCC > V_{CHG2}$, VCC recharge function stops.
- H: After the output voltage is finished rising, VCC is charged by the auxiliary winding, and VCC pin stabilizes.

(4) DCDC driver (PWM comparator, frequency hopping, slope compensation, OSC, burst)

This IC has a current mode PWM control.

An internal oscillator sets a fixed switching frequency (65 kHz Typ).

This IC has an integrated switching frequency hopping function, which causes the switching frequency to fluctuate as shown in Figure 10 below.

The fluctuation cycle is 125 Hz (Typ).

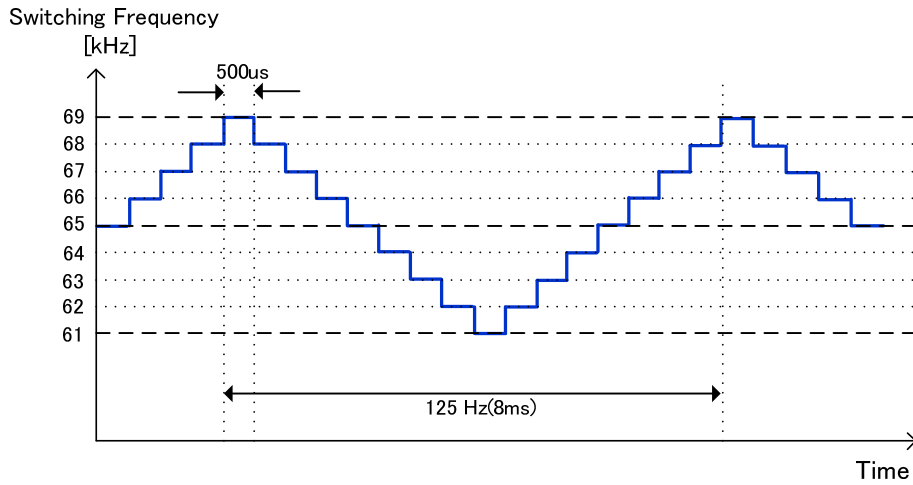

Figure 9. Frequency Hopping Function

Maximum duty cycle is fixed at 75% (Typ) and minimum pulse width is fixed at 400 ns (Typ).

In current mode control, sub-harmonic oscillation may occur when the duty cycle exceeds 50%.

As a countermeasure, this IC has built-in slope compensation circuits.

This IC has built-in burst mode and frequency reduction circuits to achieve lower power consumption when the load is light.

FB pin is pulled up by R_{FB} (30kΩ Typ).

FB pin voltage is changed by secondary output voltage (secondary load power).

FB pin is monitored, burst mode operation and frequency detection start.

Figure 10 shows the FB voltage, and the DCDC switching frequency operation.

- mode1 : Burst operation
- mode2 : Frequency reduction operation
- mode3 : Fixed frequency operation (operates at max frequency)
- mode4 : Overload operation (detects the overload state and stops the pulse operation)

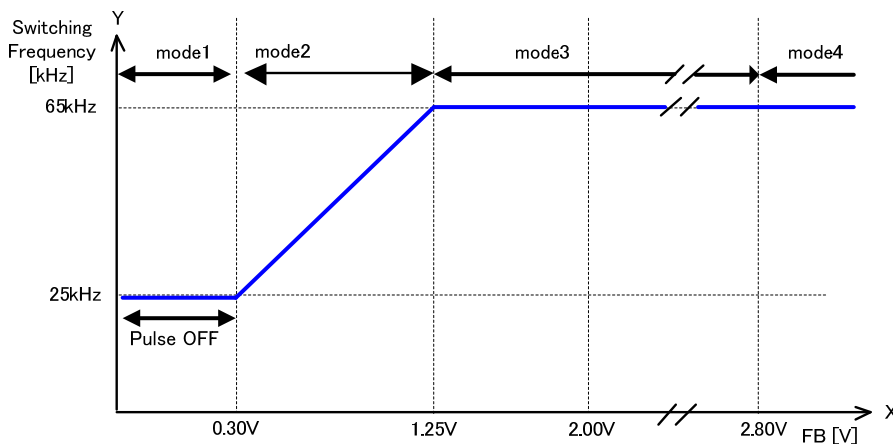

Figure 10. Switching Operation State Changes by FB Pin Voltage

(4-1) MAX Burst frequency setting

This IC can reduce a burst sound to fix a burst frequency.
 This IC has two clocks, so this IC can fix the burst frequency.

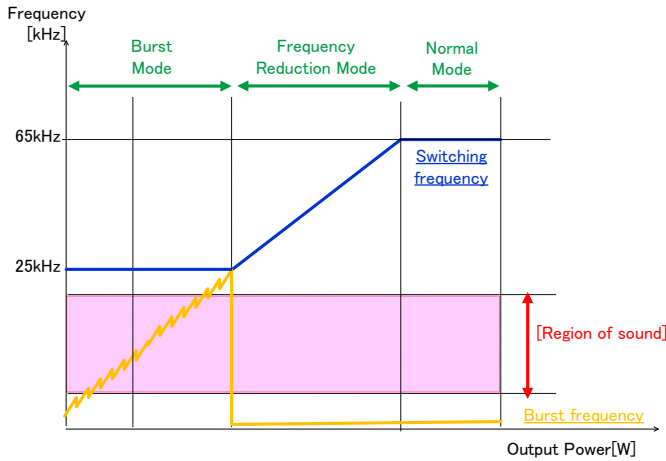

Figure 11-1. No setting

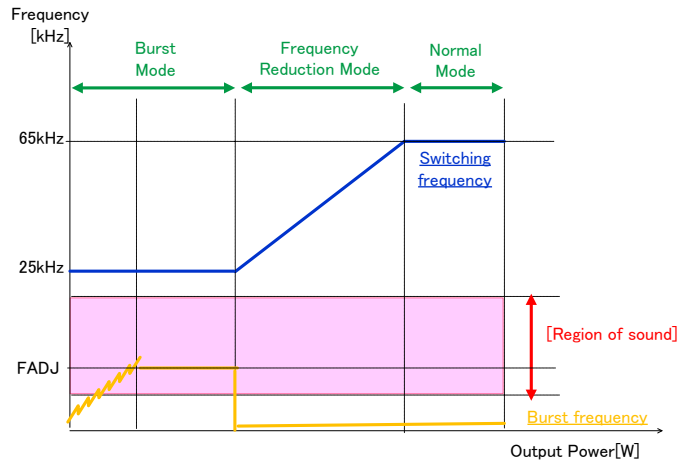

Figure 11-2. setting

Setting external capacitor of FADJ pin, the burst frequency is fixed.
 It is showed an example of max burst frequency setting using FADJ pin
 This frequency is decided by FADJ source current, FADJ comparator voltage and external capacitor.

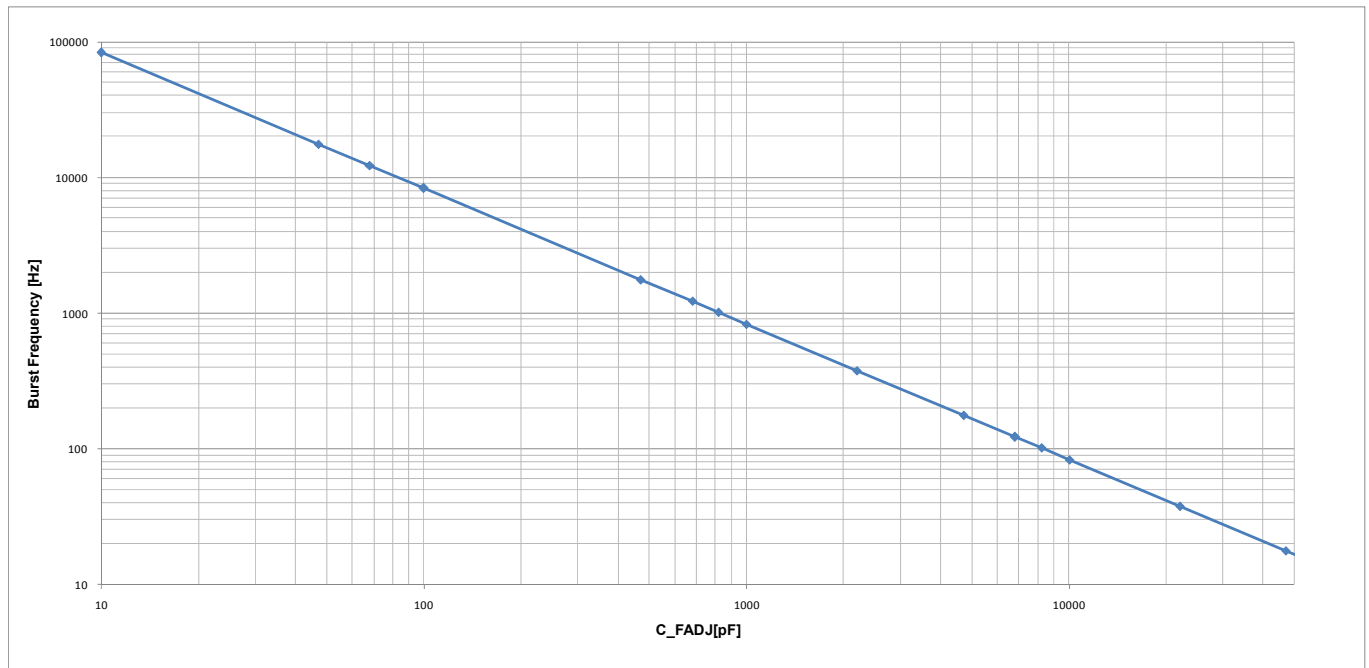

Figure 12. Example of max burst frequency setting using FADJ pin

(5) Over Current limiter

This IC has a built-in over current limiter per cycle. If the SOURCE pin exceeds a certain voltage, switching stops. It also has a built-in AC voltage compensation function. With this function, the over current limiter level is high until the time the AC voltage is compensated.

Shown in figure-13, 14, and 15

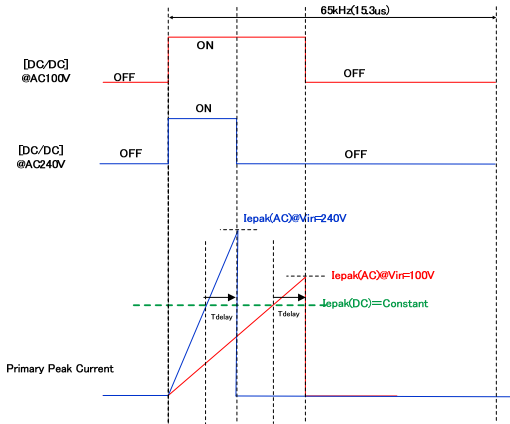

Figure 13. No AC Voltage Compensation Function

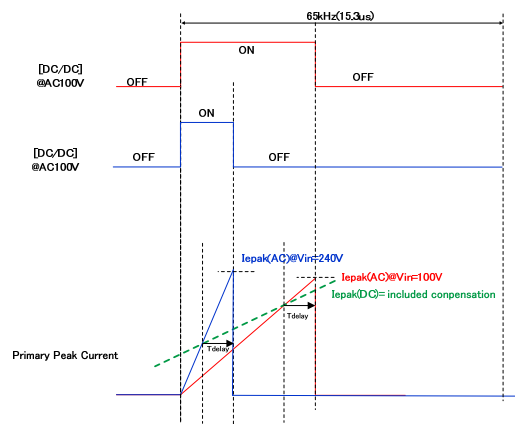

Figure 14. Built-in AC Compensation Voltage

Primary peak current is calculated using the formula below.

$$I_{peak} = V_{source} / R_s + V_{dc} / L_p * T_{delay}$$

V_{cs} : Over current limiter voltage (internal), R_s : Current detection resistance, V_{dc} : Input DC voltage, L_p : Primary inductance.

T_{delay} : Delay time after detection of over current limiter

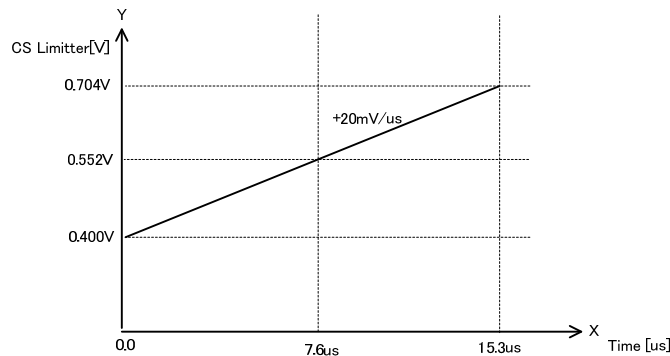

Figure 15. Over Current Limiter Voltage

(6) L. E. B. Blanking Period

When the MOSFET driver is turned ON, surge current flows through each capacitor component and drive current is generated. Therefore, when the SOURCE pin voltage rises temporarily, detection errors may occur in the over current limiter circuit. To prevent detection errors, DRAIN is switched from high to low and the SOURCE signal is masked for 250ns by the on-chip LEB (Leading Edge Blanking) function.

(7) SOURCE pin short protection function

When the SOURCE pin is shorted, This IC overheats.
This IC has a built-in short protection function to prevent destruction.

(8) SOURCE pin open protection

If the SOURCE pin becomes OPEN, This IC may be damaged.
To prevent it from being damaged, This IC has a built-in OPEN protection circuit (auto recovery protection).

(9) Output over load protection function (FB OLP Comparator)

The output overload protection function monitors the secondary output load status at the FB pin and stops switching whenever overload occurs. When there is an overload, the output voltage is reduced and current no longer flows to the photo coupler, so the FB pin voltage rises.

When the FB pin voltage $> V_{FOLP1A}$ (2.8V Typ) continuously for the period T_{FOLP} (128ms Typ), it is judged as an overload and switching stops.

When the FB pin $> V_{FOLP1A}$ (2.8V Typ), if the voltage goes lower than V_{FOLP1B} (2.6V Typ) during the period T_{FOLP} (128ms Typ), the overload protection timer is reset. The switching operation is performed during this period T_{FOLP} (128ms Typ).

At startup, the FB voltage is pulled up to the IC's internal voltage, so operation starts at a voltage of V_{FOLP1A} (2.8V Typ) or above. Therefore, at startup the FB voltage must be set to V_{FOLP1B} (2.6V Typ) or below during the period T_{FOLP} (128ms Typ), and the secondary output voltage's start time must be set within the period T_{FOLP} (128ms Typ) following startup of the IC. Recovery is after the period T_{FOLP2} (512ms Typ), from the detection of FBOLP.

•Operation mode of protection circuit

Operation mode of protection functions are shown in Table 2.

Table 2. Operation Mode of Protection Circuit

Function	Operation mode
VCC Under Voltage Locked Out	Auto recovery
VCC Over Voltage Protection	Auto recovery
TSD	Auto recovery
FB Over Limited Protection	Auto recovery
SOURCE Short Protection	Auto recovery
SOURCE Open Protection	Auto recovery

• Thermal loss

The thermal design should set operation for the following conditions.
(Since the temperature shown below is the guaranteed temperature, be sure to take a margin into account.)

1. The ambient temperature T_a must be 105°C or less.
2. The IC's loss must be within the allowable dissipation P_d .

The thermal abatement characteristics are as follows.

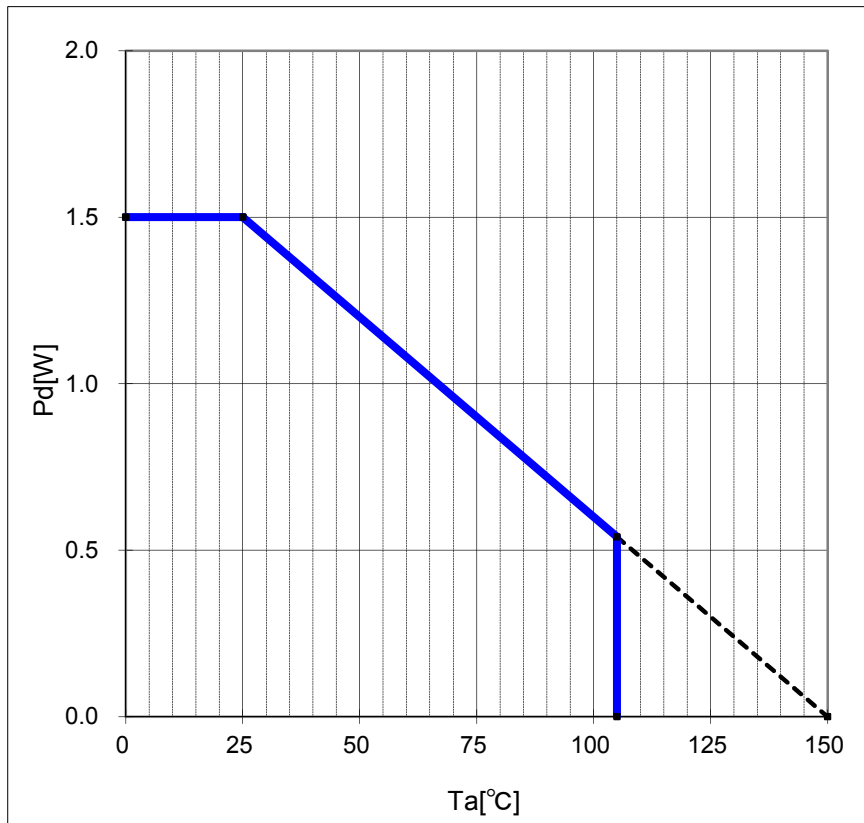

Figure 16. Thermal Abatement Characteristics

●Ordering Information

B M 2 P 0 1 6 T

-

Product name

Package
T: TO220-7M

Packaging and forming specification
None : Tube

●Physical Dimension Tape and Reel Information

TO220-7M

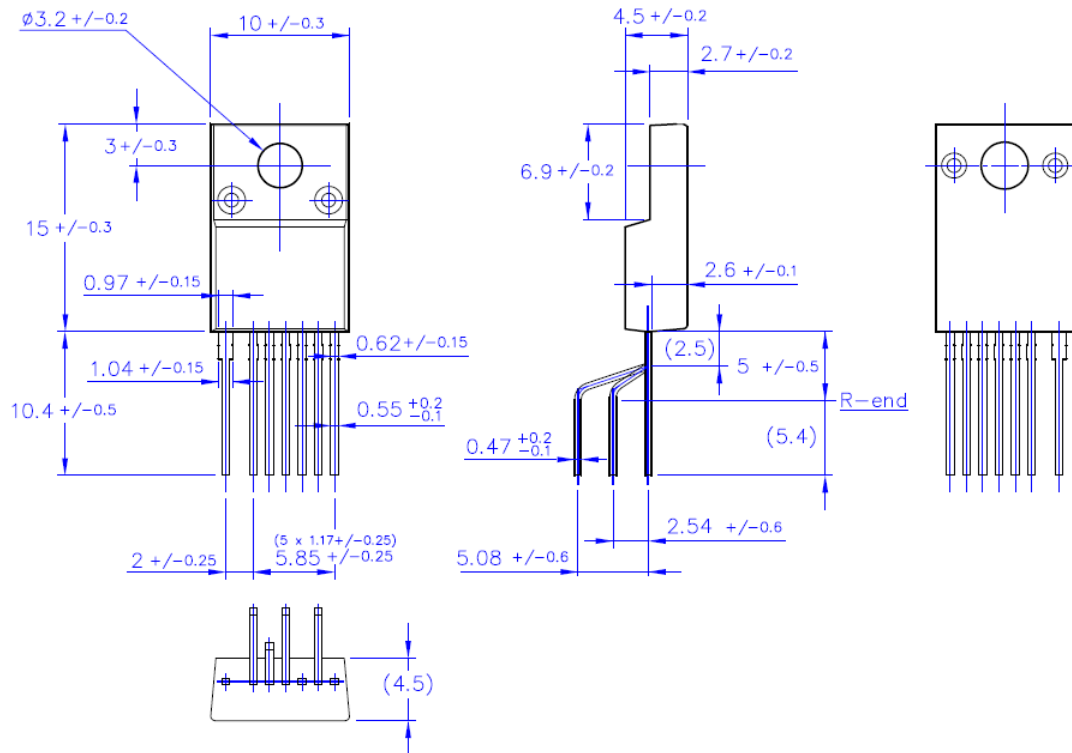

<Tape and Reel information>

Container	Tube
Quantity	238pcs
Direction of feed	Direction of products is fixed in a container tube

*Order quantity needs to be multiple of the minimum quantity.

●Marking Diagram
TO220-7M

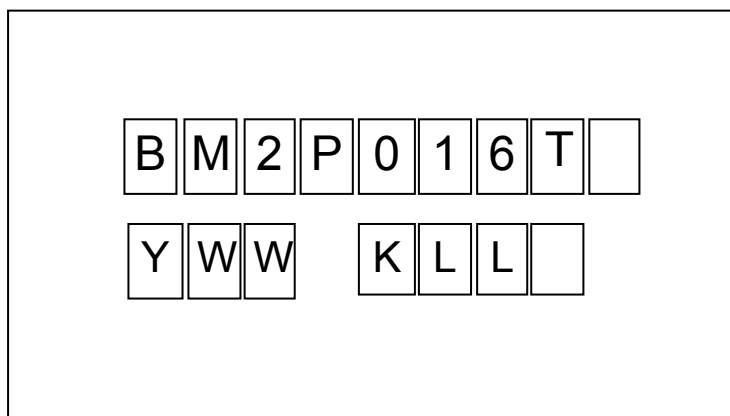

- Y: The last digit of the year (2014→4、2015→5)
- W: Input week number (01-53)
- K: Fixed character
- L: Running Code00-99 (Reset every week)

Operational Notes

1. Reverse Connection of Power Supply

Connecting the power supply in reverse polarity can damage the IC. Take precautions against reverse polarity when connecting the power supply, such as mounting an external diode between the power supply and the IC's power supply pins.

2. Power Supply Lines

Design the PCB layout pattern to provide low impedance supply lines. Separate the ground and supply lines of the digital and analog blocks to prevent noise in the ground and supply lines of the digital block from affecting the analog block. Furthermore, connect a capacitor to ground at all power supply pins. Consider the effect of temperature and aging on the capacitance value when using electrolytic capacitors.

3. Ground Voltage

Ensure that no pins are at a voltage below that of the ground pin at any time, even during transient condition.

4. Ground Wiring Pattern

When using both small-signal and large-current ground traces, the two ground traces should be routed separately but connected to a single ground at the reference point of the application board to avoid fluctuations in the small-signal ground caused by large currents. Also ensure that the ground traces of external components do not cause variations on the ground voltage. The ground lines must be as short and thick as possible to reduce line impedance.

5. Thermal Consideration

Should by any chance the maximum junction temperature rating be exceeded the rise in temperature of the chip may result in deterioration of the properties of the chip. In case of exceeding this absolute maximum rating, increase the board size and copper area to prevent exceeding the maximum junction temperature rating.

6. Recommended Operating Conditions

These conditions represent a range within which the expected characteristics of the IC can be approximately obtained. The electrical characteristics are guaranteed under the conditions of each parameter.

7. Inrush Current

When power is first supplied to the IC, it is possible that the internal logic may be unstable and inrush current may flow instantaneously due to the internal powering sequence and delays, especially if the IC has more than one power supply. Therefore, give special consideration to power coupling capacitance, power wiring, width of ground wiring, and routing of connections.

8. Operation Under Strong Electromagnetic Field

Operating the IC in the presence of a strong electromagnetic field may cause the IC to malfunction.

9. Testing on Application Boards

When testing the IC on an application board, connecting a capacitor directly to a low-impedance output pin may subject the IC to stress. Always discharge capacitors completely after each process or step. The IC's power supply should always be turned off completely before connecting or removing it from the test setup during the inspection process. To prevent damage from static discharge, ground the IC during assembly and use similar precautions during transport and storage.

10. Inter-pin Short and Mounting Errors

Ensure that the direction and position are correct when mounting the IC on the PCB. Incorrect mounting may result in damaging the IC. Avoid nearby pins being shorted to each other especially to ground, power supply and output pin. Inter-pin shorts could be due to many reasons such as metal particles, water droplets (in very humid environment) and unintentional solder bridge deposited in between pins during assembly to name a few.

Operational Notes – continued

11. Unused Input Pins

Input pins of an IC are often connected to the gate of a MOS transistor. The gate has extremely high impedance and extremely low capacitance. If left unconnected, the electric field from the outside can easily charge it. The small charge acquired in this way is enough to produce a significant effect on the conduction through the transistor and cause unexpected operation of the IC. So unless otherwise specified, unused input pins should be connected to the power supply or ground line.

12. Regarding the Input Pin of the IC

This monolithic IC contains P+ isolation and P substrate layers between adjacent elements in order to keep them isolated. P-N junctions are formed at the intersection of the P layers with the N layers of other elements, creating a parasitic diode or transistor. For example (refer to figure below):

When $GND > Pin A$ and $GND > Pin B$, the P-N junction operates as a parasitic diode.
When $GND > Pin B$, the P-N junction operates as a parasitic transistor.

Parasitic diodes inevitably occur in the structure of the IC. The operation of parasitic diodes can result in mutual interference among circuits, operational faults, or physical damage. Therefore, conditions that cause these diodes to operate, such as applying a voltage lower than the GND voltage to an input pin (and thus to the P substrate) should be avoided.

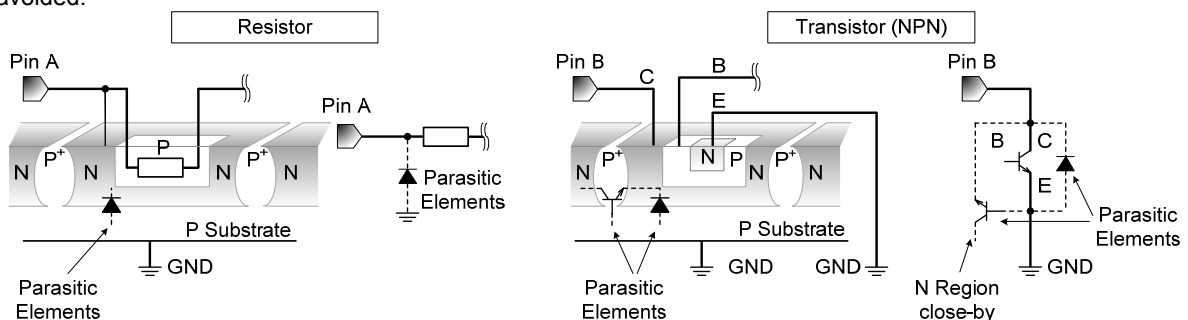

Figure. Example of monolithic IC structure

13. Ceramic Capacitor

When using a ceramic capacitor, determine the dielectric constant considering the change of capacitance with temperature and the decrease in nominal capacitance due to DC bias and others.

14. Area of Safe Operation (ASO)

Operate the IC such that the output voltage, output current, and power dissipation are all within the Area of Safe Operation (ASO).

15. Thermal Shutdown Circuit(TSD)

This IC has a built-in thermal shutdown circuit that prevents heat damage to the IC. Normal operation should always be within the IC's maximum junction temperature rating. If however the rating is exceeded for a continued period, the junction temperature (T_j) will rise which will activate the TSD circuit that will turn OFF all output pins. When the T_j falls below the TSD threshold, the circuits are automatically restored to normal operation.

Note that the TSD circuit operates in a situation that exceeds the absolute maximum ratings and therefore, under no circumstances, should the TSD circuit be used in a set design or for any purpose other than protecting the IC from heat damage.

16. Over Current Protection Circuit (OCP)

This IC incorporates an integrated over current protection circuit that is activated when the load is shorted. This protection circuit is effective in preventing damage due to sudden and unexpected incidents. However, the IC should not be used in applications characterized by continuous operation or transitioning of the protection circuit.

Date	Rev. No.	Revision Point
2016.11.1	001	New Release
2017.4.7	002	Change the diagram on P14
2017.4.18	003	Change the diagram on P14

Notice

Precaution on using ROHM Products

- Our Products are designed and manufactured for application in ordinary electronic equipments (such as AV equipment, OA equipment, telecommunication equipment, home electronic appliances, amusement equipment, etc.). If you intend to use our Products in devices requiring extremely high reliability (such as medical equipment ^(Note 1), transport equipment, traffic equipment, aircraft/spacecraft, nuclear power controllers, fuel controllers, car equipment including car accessories, safety devices, etc.) and whose malfunction or failure may cause loss of human life, bodily injury or serious damage to property ("Specific Applications"), please consult with the ROHM sales representative in advance. Unless otherwise agreed in writing by ROHM in advance, ROHM shall not be in any way responsible or liable for any damages, expenses or losses incurred by you or third parties arising from the use of any ROHM's Products for Specific Applications.

(Note1) Medical Equipment Classification of the Specific Applications

JAPAN	USA	EU	CHINA
CLASS III	CLASS III	CLASS II b	CLASS III
CLASS IV		CLASS III	

- ROHM designs and manufactures its Products subject to strict quality control system. However, semiconductor products can fail or malfunction at a certain rate. Please be sure to implement, at your own responsibilities, adequate safety measures including but not limited to fail-safe design against the physical injury, damage to any property, which a failure or malfunction of our Products may cause. The following are examples of safety measures:
 - Installation of protection circuits or other protective devices to improve system safety
 - Installation of redundant circuits to reduce the impact of single or multiple circuit failure
- Our Products are designed and manufactured for use under standard conditions and not under any special or extraordinary environments or conditions, as exemplified below. Accordingly, ROHM shall not be in any way responsible or liable for any damages, expenses or losses arising from the use of any ROHM's Products under any special or extraordinary environments or conditions. If you intend to use our Products under any special or extraordinary environments or conditions (as exemplified below), your independent verification and confirmation of product performance, reliability, etc. prior to use, must be necessary:
 - Use of our Products in any types of liquid, including water, oils, chemicals, and organic solvents
 - Use of our Products outdoors or in places where the Products are exposed to direct sunlight or dust
 - Use of our Products in places where the Products are exposed to sea wind or corrosive gases, including Cl₂, H₂S, NH₃, SO₂, and NO₂
 - Use of our Products in places where the Products are exposed to static electricity or electromagnetic waves
 - Use of our Products in proximity to heat-producing components, plastic cords, or other flammable items
 - Sealing or coating our Products with resin or other coating materials
 - Use of our Products without cleaning residue of flux (even if you use no-clean type fluxes, cleaning residue of flux is recommended); or Washing our Products by using water or water-soluble cleaning agents for cleaning residue after soldering
 - Use of the Products in places subject to dew condensation
- The Products are not subject to radiation-proof design.
- Please verify and confirm characteristics of the final or mounted products in using the Products.
- In particular, if a transient load (a large amount of load applied in a short period of time, such as pulse. is applied, confirmation of performance characteristics after on-board mounting is strongly recommended. Avoid applying power exceeding normal rated power; exceeding the power rating under steady-state loading condition may negatively affect product performance and reliability.
- De-rate Power Dissipation depending on ambient temperature. When used in sealed area, confirm that it is the use in the range that does not exceed the maximum junction temperature.
- Confirm that operation temperature is within the specified range described in the product specification.
- ROHM shall not be in any way responsible or liable for failure induced under deviant condition from what is defined in this document.

Precaution for Mounting / Circuit board design

- When a highly active halogenous (chlorine, bromine, etc.) flux is used, the residue of flux may negatively affect product performance and reliability.
- In principle, the reflow soldering method must be used on a surface-mount products, the flow soldering method must be used on a through hole mount products. If the flow soldering method is preferred on a surface-mount products, please consult with the ROHM representative in advance.

For details, please refer to ROHM Mounting specification

Precautions Regarding Application Examples and External Circuits

1. If change is made to the constant of an external circuit, please allow a sufficient margin considering variations of the characteristics of the Products and external components, including transient characteristics, as well as static characteristics.
2. You agree that application notes, reference designs, and associated data and information contained in this document are presented only as guidance for Products use. Therefore, in case you use such information, you are solely responsible for it and you must exercise your own independent verification and judgment in the use of such information contained in this document. ROHM shall not be in any way responsible or liable for any damages, expenses or losses incurred by you or third parties arising from the use of such information.

Precaution for Electrostatic

This Product is electrostatic sensitive product, which may be damaged due to electrostatic discharge. Please take proper caution in your manufacturing process and storage so that voltage exceeding the Products maximum rating will not be applied to Products. Please take special care under dry condition (e.g. Grounding of human body / equipment / solder iron, isolation from charged objects, setting of Ionizer, friction prevention and temperature / humidity control).

Precaution for Storage / Transportation

1. Product performance and soldered connections may deteriorate if the Products are stored in the places where:
 - [a] the Products are exposed to sea winds or corrosive gases, including Cl₂, H₂S, NH₃, SO₂, and NO₂
 - [b] the temperature or humidity exceeds those recommended by ROHM
 - [c] the Products are exposed to direct sunshine or condensation
 - [d] the Products are exposed to high Electrostatic
2. Even under ROHM recommended storage condition, solderability of products out of recommended storage time period may be degraded. It is strongly recommended to confirm solderability before using Products of which storage time is exceeding the recommended storage time period.
3. Store / transport cartons in the correct direction, which is indicated on a carton with a symbol. Otherwise bent leads may occur due to excessive stress applied when dropping of a carton.
4. Use Products within the specified time after opening a humidity barrier bag. Baking is required before using Products of which storage time is exceeding the recommended storage time period.

Precaution for Product Label

A two-dimensional barcode printed on ROHM Products label is for ROHM's internal use only.

Precaution for Disposition

When disposing Products please dispose them properly using an authorized industry waste company.

Precaution for Foreign Exchange and Foreign Trade act

Since concerned goods might be fallen under listed items of export control prescribed by Foreign exchange and Foreign trade act, please consult with ROHM in case of export.

Precaution Regarding Intellectual Property Rights

1. All information and data including but not limited to application example contained in this document is for reference only. ROHM does not warrant that foregoing information or data will not infringe any intellectual property rights or any other rights of any third party regarding such information or data.
2. ROHM shall not have any obligations where the claims, actions or demands arising from the combination of the Products with other articles such as components, circuits, systems or external equipment (including software).
3. No license, expressly or implied, is granted hereby under any intellectual property rights or other rights of ROHM or any third parties with respect to the Products or the information contained in this document. Provided, however, that ROHM will not assert its intellectual property rights or other rights against you or your customers to the extent necessary to manufacture or sell products containing the Products, subject to the terms and conditions herein.

Other Precaution



1. This document may not be reprinted or reproduced, in whole or in part, without prior written consent of ROHM.
2. The Products may not be disassembled, converted, modified, reproduced or otherwise changed without prior written consent of ROHM.
3. In no event shall you use in any way whatsoever the Products and the related technical information contained in the Products or this document for any military purposes, including but not limited to, the development of mass-destruction weapons.
4. The proper names of companies or products described in this document are trademarks or registered trademarks of ROHM, its affiliated companies or third parties.

General Precaution

1. Before you use our Products, you are requested to carefully read this document and fully understand its contents. ROHM shall not be in any way responsible or liable for failure, malfunction or accident arising from the use of any ROHM's Products against warning, caution or note contained in this document.
2. All information contained in this document is current as of the issuing date and subject to change without any prior notice. Before purchasing or using ROHM's Products, please confirm the latest information with a ROHM sales representative.
3. The information contained in this document is provided on an "as is" basis and ROHM does not warrant that all information contained in this document is accurate and/or error-free. ROHM shall not be in any way responsible or liable for any damages, expenses or losses incurred by you or third parties resulting from inaccuracy or errors of or concerning such information.

Looking for pricing, stock, or lifecycle information?

Click below to explore more details on WIN SOURCE:

-  [View BM2P016T-Z on WIN SOURCE](#)
-  [Rohm Semiconductor](#) Information

Optimize Your Supply Chain with WIN SOURCE Solutions

-  Global Sourcing Solution
-  Obsolete Management
-  Cost Control Management
-  Shortage Management
-  Alternative Solution
-  Excess Inventory Management