



**THE DATASHEET OF  
BM2P161W-Z**



AC/DC Convertor IC

**PWM type DC/DC converter IC**

**Integrated Switching MOSFET for non-Isolated type**  
**BM2P161W-Z**

**General Description**

The PWM type DC/DC converter series for AC/DC provides an optimum system for all products that include an electrical outlet. It enables simpler design of a high effective converter specializing in non-isolated devices.

This series has a built-in HV starter circuit that tolerates 650V, and it contributes to low power consumption. With a current detection resistor as internal device, it can be designed as small power supply. Since current mode control is utilized, current is restricted in each cycle and excellent performance is demonstrated in bandwidth and transient response. The switching frequency is fixed to 65 kHz. At light load, the switching frequency is reduced and high efficiency is achieved. A frequency hopping function is also on chip, and it contributes to low EMI. In addition, a built-in super junction MOSFET which tolerates 650V makes the design easy.

**Features**

- PWM frequency: 65kHz
- PWM current mode method
- Frequency hopping function
- Burst operation at light load
- Frequency reduction function
- Built-in 650V start circuit
- Built-in 650V switching MOSFET
- VCC pin under voltage protection
- VCC pin over voltage protection
- Over current limiter function per cycle
- Soft start function

**Basic Specification**

■ Power Supply Voltage Operation Range:  
VCC: 8.00V to 18.16V  
DRAIN: to 650V

■ Normal Operation Current 1.50mA (Typ.)  
 ■ Burst Operation Current 0.35mA(Typ.)  
 ■ Oscillation Frequency 65kHz(Typ.)  
 ■ Operation Temperature Range - 40 °C to +105 °C  
 ■ MOSFET ON resistor: 1.9Ω (Typ.)

**Package**

DIP7K  
DIP7WF

**W (Typ) x D (Typ) x H (Max)**

9.27 mm x 6.35 mm x 8.63 mm  
Pitch 2.54 mm  
9.35mm x 6.35mm x 8.10mm  
Pitch 2.54mm

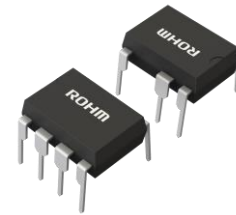

**Application**

Households such as LED lights, air conditioners, and cleaners, etc.).

**Application circuit**

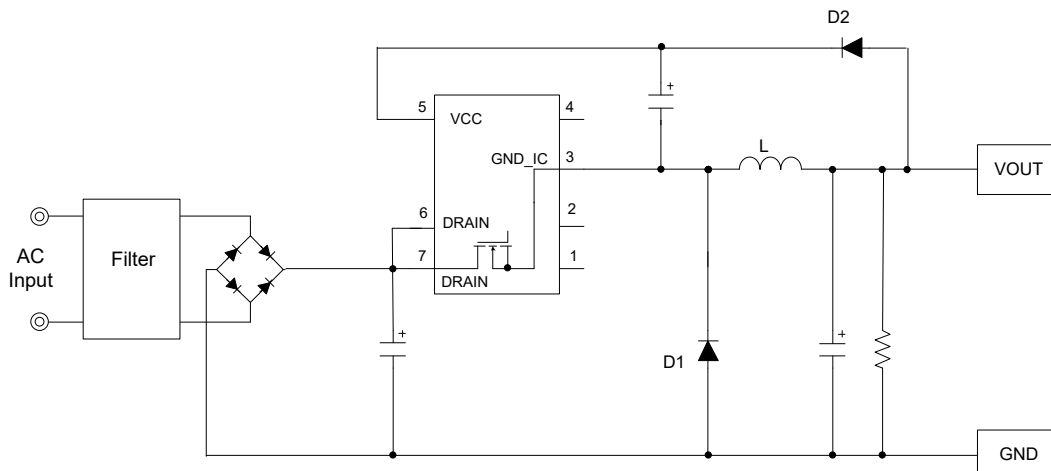

Pin Descriptions

NO.	端子名	I/O	機能	ESD Diode	
				VCC	GND_IC
1	-	-	-	-	-
2	-	-	-	-	-
3	GND_IC	I/O	GND pin	✓	-
4	-	-	-	-	-
5	VCC	I	Power Supply input pin	-	✓
6	DRAIN	I/O	MOSFET DRAIN pin	-	✓
7	DRAIN	I/O	MOSFET DRAIN pin	-	✓

Block Diagram

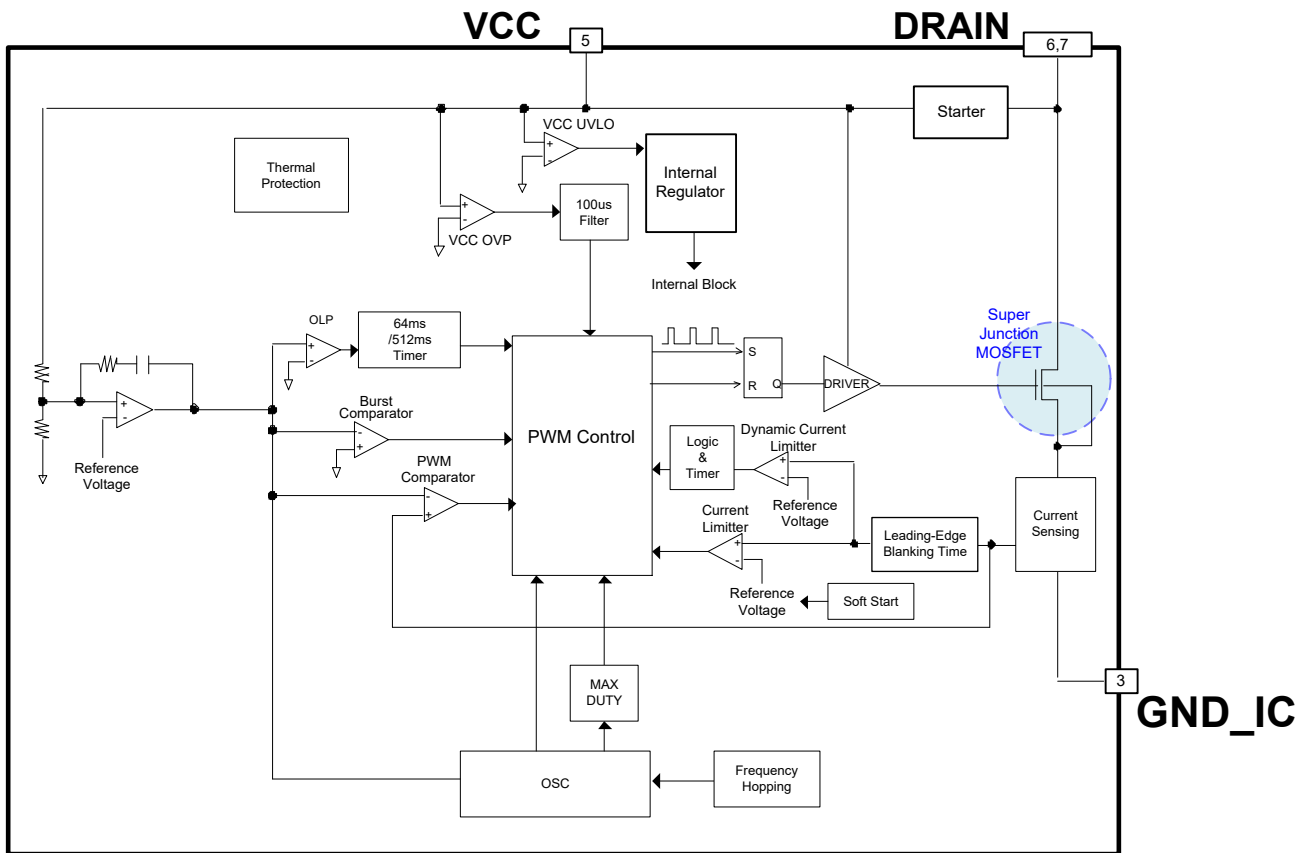

**Absolute Maximum Ratings (Ta=25 °C)**

Parameter	Symbol	Rating	Unit	Conditions
Maximum applied voltage 1	$V_{max1}$	-0.3 to 650	V	DRAIN
Maximum applied voltage 2	$V_{max2}$	-0.3 to 32.0	V	VCC
DRAIN current DC 2	$I_{D2}$	10.40	A	Consecutive operation
Allowable dissipation	$P_d$	1.00	W	
Operating temperature range	$T_{opr}$	-40 to +105	°C	Surrounding temperature
Maximum Junction Temperature	$T_{jmax}$	+150	°C	
Storage temperature range	$T_{str}$	-55 to +150	°C	

(Note1) Derate by 8mW/°C when operating above Ta = 25°C when mounted (on 70 mm × 70 mm, 1.6 mm thick, glass epoxy on single-layer substrate).

**Caution:** Operating the IC over the absolute maximum ratings may damage the IC. The damage can either be a short circuit between pins or an open circuit between pins and the internal circuitry. Therefore, it is important to consider circuit protection measures, such as adding a fuse, in case the IC is operated over the absolute maximum ratings.

**Recommended operating condition (Ta=25 °C)**

Parameter	Symbol	Rating	Unit	Conditions
Power supply voltage range 1	$V_{DRAIN}$	~650	V	DRAIN
Power supply voltage range 2	$V_{CC}$	8.00 to 18.16	V	VCC

**Electrical Characteristics in MOSFET part (Unless otherwise noted, Ta=25 °C VCC=15V)**

Parameter	Symbol	Specifications			Unit	Conditions
		Minimum	Standard	Maximum		
Voltage between DRAIN and SOURCE	$V_{(BR)DDS}$	650	-	-	V	$I_D=1mA / V_{GS}=0V$
DRAIN leak current	$I_{DSS}$	-	0	100	uA	$V_{DS}=650V / V_{GS}=0V$
ON resistor2	$R_{DS(ON)2}$	-	1.9	2.6	Ω	$I_D=0.25A / V_{GS}=10V$

**Electrical Characteristics in Start circuits part (Unless otherwise noted, Ta=25 °C VCC=15V)**

Parameter	Symbol	Specifications			Unit	Conditions
		Minimum	Standard	Maximum		
Start current 1	$I_{START1}$	0.150	0.300	2.800	mA	VCC= 0V
Start current 2	$I_{START2}$	1.000	3.000	6.000	mA	VCC=10V
OFF current	$I_{START3}$	-	10	20	uA	After UVLO is released
Start current switching voltage	$V_{SC}$	0.400	0.800	1.300	V	

## Electrical Characteristics in Control IC part (Unless otherwise noted, Ta=25 °C VCC=15V)

Parameter	Symbol	Specifications			Unit	Conditions
		Minimum	Standard	Maximum		
[Circuit current]						
Circuit current (ON) 1b	I <sub>ON1b</sub>	-	1500	2100	μA	At pulse operation Drain = open
Circuit current (ON) 2	I <sub>ON2</sub>	200	350	450	μA	At burst operation
[VCC pin protection function]						
VCC UVLO voltage 1	V <sub>UVLO1</sub>	8.10	8.80	9.50	V	At VCC rising
VCC UVLO voltage 2	V <sub>UVLO2</sub>	6.60	7.30	8.00	V	At VCC dropping
VCC UVLO hysteresis	V <sub>UVLO3</sub>	-	1.50	-	V	V <sub>UVLO3</sub> = V <sub>UVLO1</sub> - V <sub>UVLO2</sub>
VCC recharge start voltage	V <sub>CHG1</sub>	7.00	7.70	8.40	V	
VCC recharge stop voltage	V <sub>CHG2</sub>	7.40	8.10	8.80	V	
VCC recharge hysteresis	V <sub>CHG3</sub>	0.20	0.40	0.70	V	
VCC control voltage	V <sub>CNT</sub>	16.63	16.80	16.97	V	
VCC OVP voltage 1	V <sub>OV1</sub>	18.16	19.32	20.48	V	At VCC rising
VCC OVP voltage 2	V <sub>OV2</sub>	17.37	18.48	19.59	V	At VCC dropping
VCC OVP hysteresis	V <sub>OV3</sub>	-	0.84	-	V	
VCC OVP timer	T <sub>COMP</sub>	50	100	150	us	
Over temperature protection 1	T <sub>SD1</sub>	120	150	-	°C	Control IC part At temperature rising
Over temperature protection 2	T <sub>SD2</sub>	-	85	-	°C	Control IC part At temperature dropping
Over temperature protection hysteresis	T <sub>SD3</sub>	-	65	-	°C	
[PWM type DC/DC driver block]						
Oscillation frequency 1	F <sub>SW1</sub>	60	65	70	KHz	
Oscillation frequency 2	F <sub>SW2</sub>	18	25	32	KHz	
Frequency hopping width	F <sub>DEL</sub>	-	4.0	-	KHz	
Maximum duty	D <sub>max</sub>	35	40	45	%	
FB OLP ON detection timer	T <sub>FOLP1</sub>	40	64	88	ms	
FB OLP OFF detection timer	T <sub>FOLP2</sub>	332	512	692	ms	
Soft Start Time1	SS1	2.8	4.0	5.2	ms	
Soft Start Time2	SS2	5.6	8.0	10.4	ms	
Soft Start Time3	SS3	11.2	16.0	20.8	ms	
[Over current detection block]						
Over current detection current	I <sub>PEAK</sub>	1.310	1.460	1.610	A	
Over current detection in SS1	I <sub>PEAK1</sub>	-	1.095	-	A	*1
Over current detection in SS2	I <sub>PEAK2</sub>	-	0.730	-	A	*1
Over current detection in SS3	I <sub>PEAK3</sub>	-	0.365	-	A	*1
Dynamic over current detection current	I <sub>DPEAK</sub>	3.600	4.015	4.430	A	
Dynamic over current detection in SS1	I <sub>DPEAK1</sub>	-	3.011	-	A	*1
Dynamic over current detection in SS2	I <sub>DPEAK2</sub>	-	2.008	-	A	*1
Dynamic over current detection in SS3	I <sub>DPEAK3</sub>	-	1.004	-	A	*1
Dynamic over current enforced OFF time	T <sub>DPEAK</sub>	64	128	170	us	
Leading Edge Blanking time	T <sub>LEB</sub>	-	(150)	-	ns	*1
MIN ON width	T <sub>MINON</sub>	-	(400)	-	ns	*1

\*1 Design guarantee data

**Description of Blocks**

**(1) Back converter**

This is the IC for exclusive use of non-isolated type back converter.

<Basic operation of back converter>

**(1-1) when the MOSFET for switching is ON**

When the MOSFET turns ON, current  $I_L$  flows to coil L and energy is stored. At this moment, the voltage of GND\_IC becomes the voltage near DRAIN pin, and the diode D1 is OFF.

$$I_L = (V_{IN} - V_{OUT}) / L * T_{on}$$

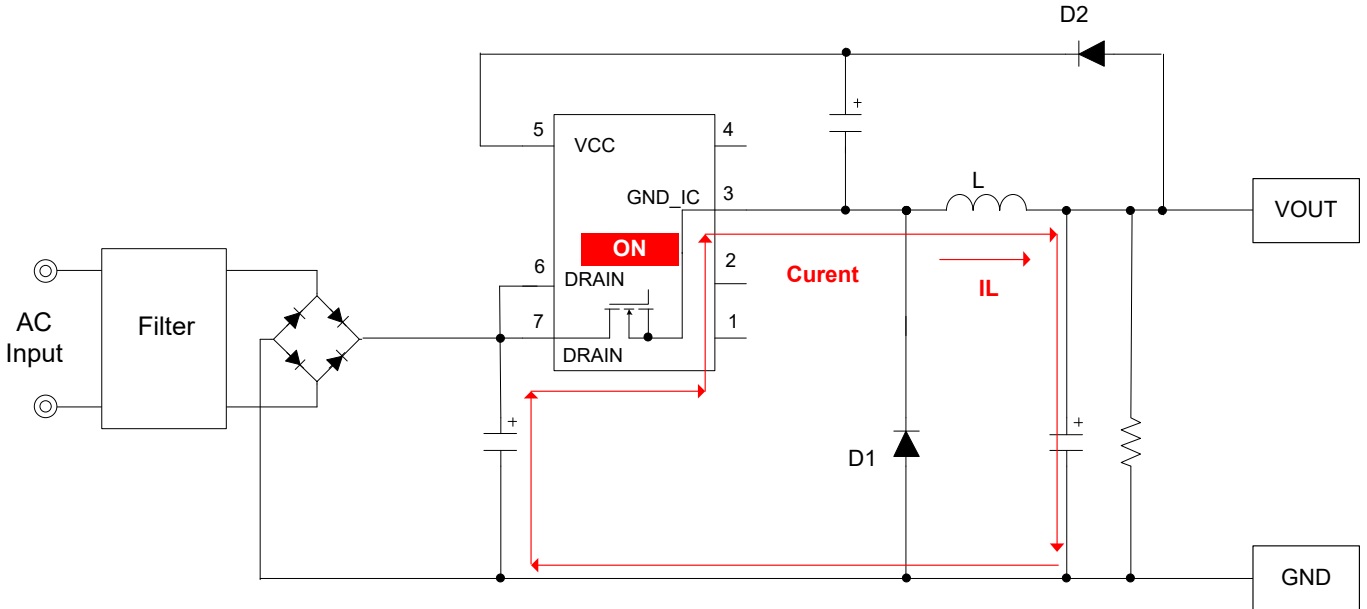

Figure 1. Back converter operation (MOSFET=ON)

**(1-2) when the MOSFET for switching is OFF**

When the MOSFET turns OFF, the energy stored in coil is output via diode. At the moment, the MOSFET is OFF.

$$I_L = (V_{OUT}) / L * T_{off}$$

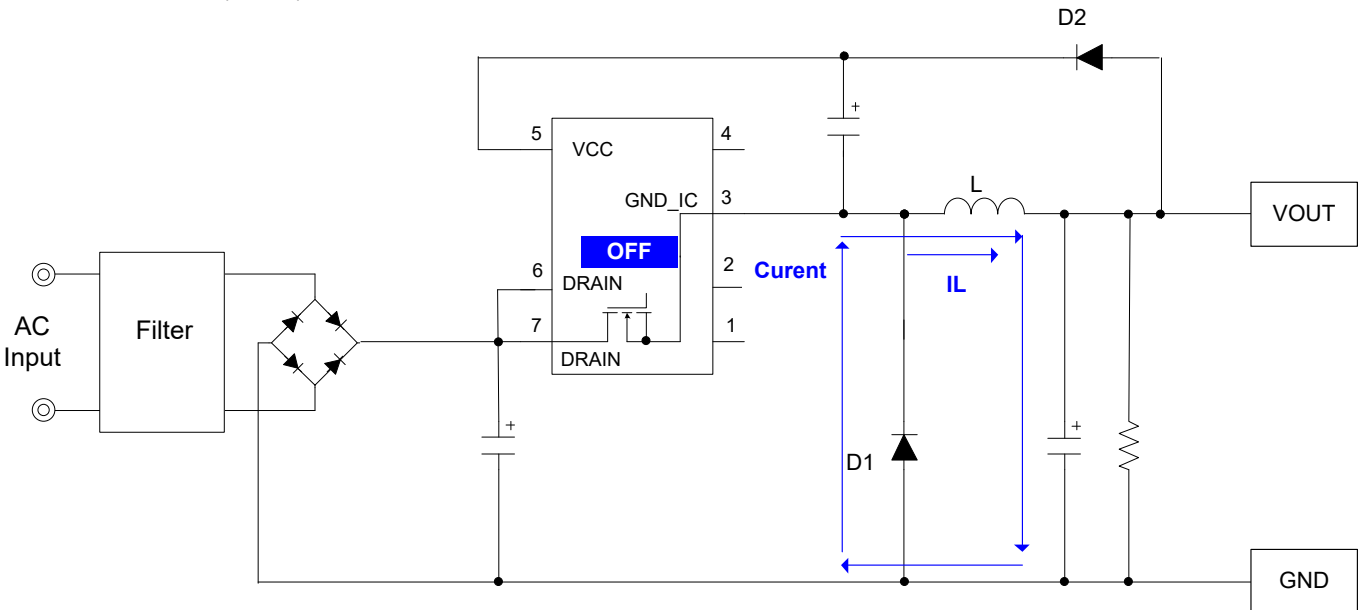

Figure 2. Back converter operation (MOSFET=OFF)

(2) Start sequences (start-up operation, light load operation, over load protection function)

Start sequences are shown in Figure 3. See the sections below for detailed descriptions.

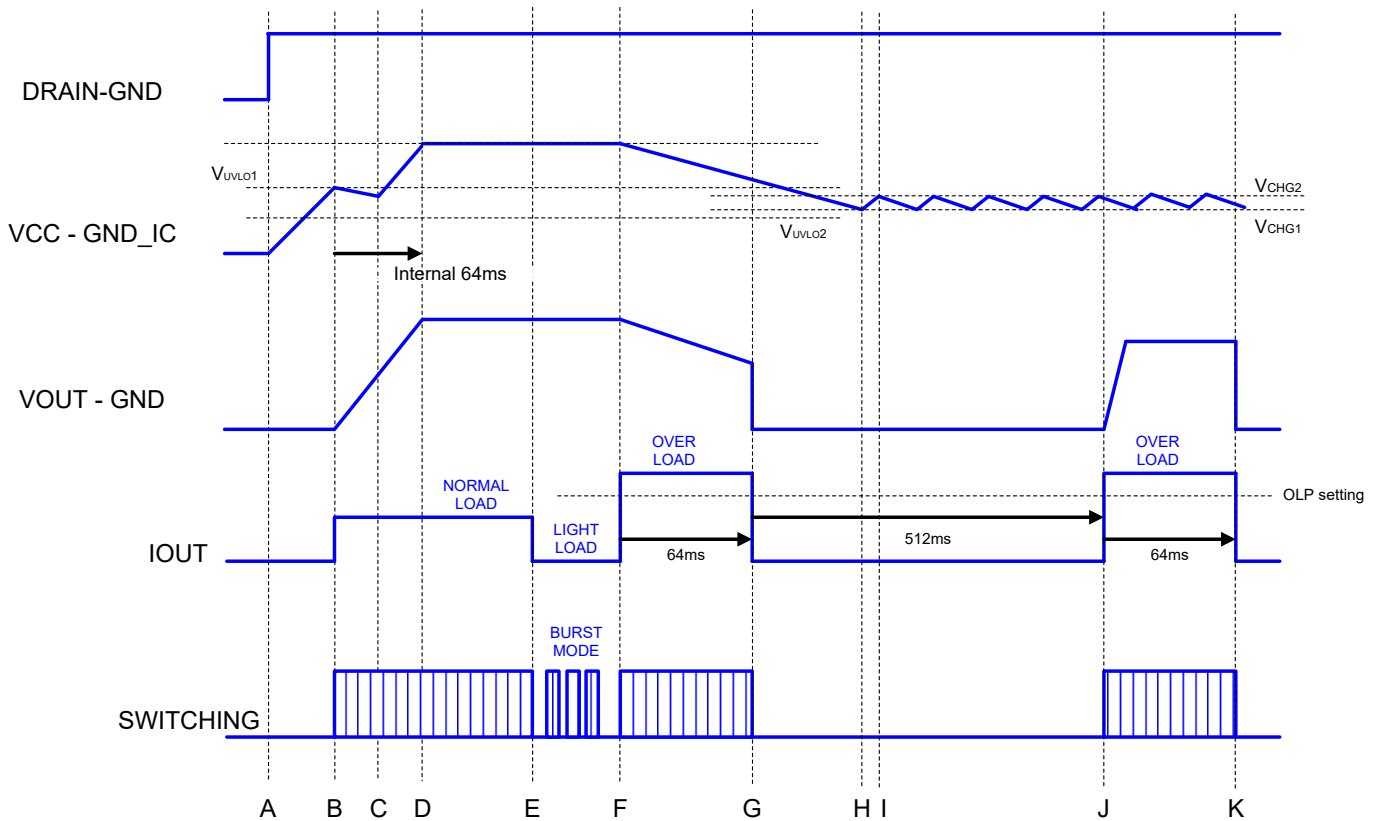

Figure 3. Start sequences timing chart

- A: Input voltage is applied to the DRAIN pin and the VCC pin voltage rises.
- B: If the VCC pin voltage exceeds  $V_{UVLO1}$ , the IC starts to operate. And if the IC judges the other protection functions as normal condition, it starts switching operation. The soft start function limits the over current limiter value to prevent any excessive voltage or current rising. When the switching operation starts, the VOUT rises.
- C: Till the secondary input voltage becomes constant value from starting-up, the VCC pin voltage drops by the VCC pin consumption current.
- D: After switching starts, it is necessary that the output voltage is set to rating voltage within  $T_{FOLP}$  (64ms typ.).
- E: At light load, the IC starts burst operation to restrict the consumption power.
- F: When the load exceeds a certain electric power, the IC starts over load operation.
- G: If the setting over load status lasts for  $T_{FOLP}$  (64ms typ.), switching is turned OFF.
- H: When the VCC pin voltage becomes less than  $V_{CHG1}$ , recharge operation is started.
- I: When the VCC pin voltage becomes more than  $V_{CHG2}$ , recharge operation is stopped.
- J: After  $T_{OLPST}$  (512ms typ.), the over load protection circuit starts switching.
- K: Same as G

(3) Stop sequences

Stop sequences are shown in Figure 4.

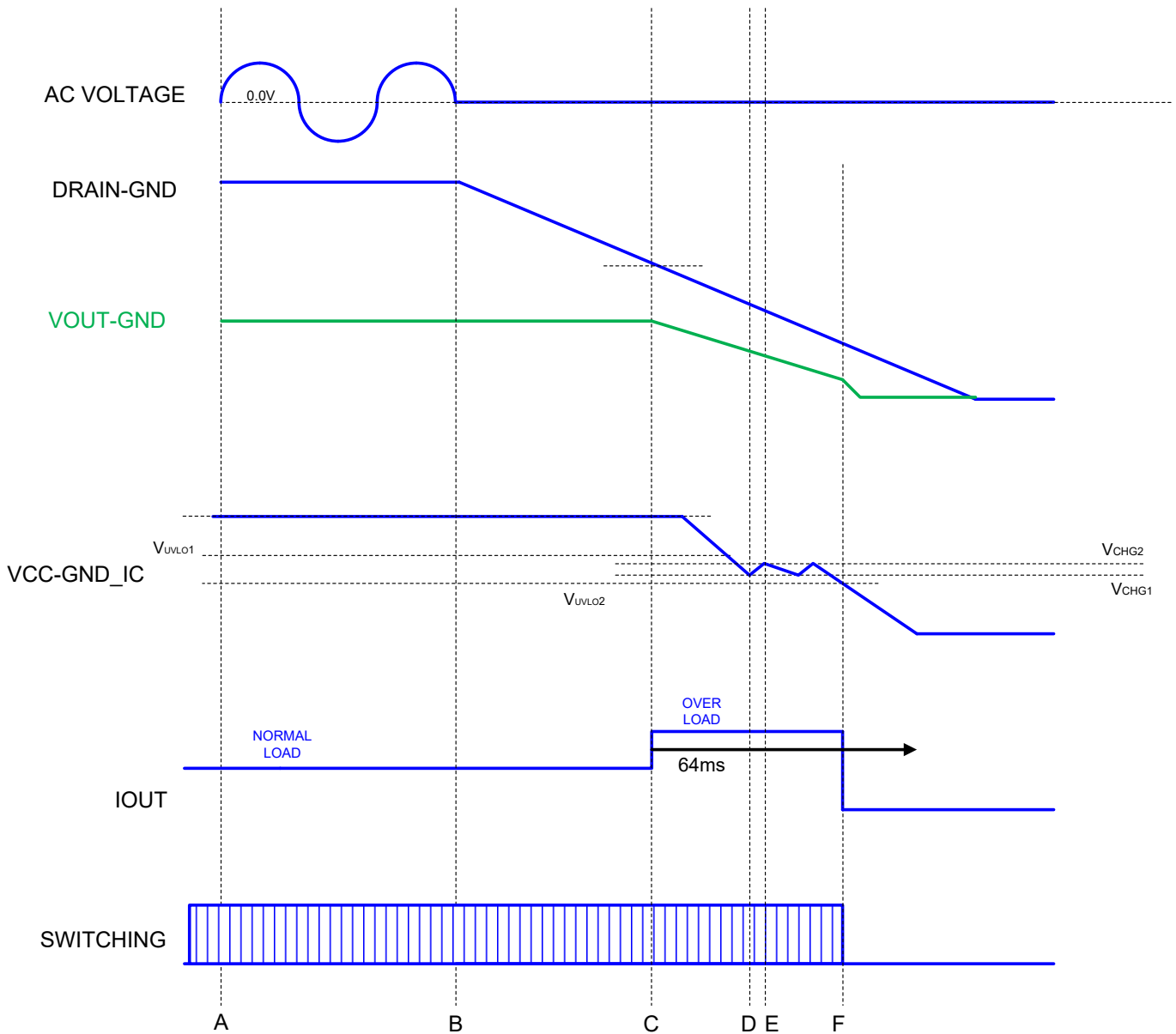

Figure 4. Stop sequences timing chart

- A: Normal operation
- B: The input AC voltage is stopped. The DRAIN voltage starts to drop.
- C: If the DRAIN voltage drops below a certain voltage, it becomes MAX duty and over load protection operates.
- D: If the output voltage drops, the VCC pin voltage, too. And recharge operation is started.
- E: The recharge operation is stopped.
- F: If the DRAIN voltage drops below a certain voltage, the VCC pin voltage lowers below UVLO in order to stop recharge operation.

(4) Start circuit

This IC enables low standby electric power and high-speed startup because it has a built-in start circuit. The consumption current after startup is only idling current  $I_{DSS}$  (typ=10uA). The startup current flows from the DRAIN pin.

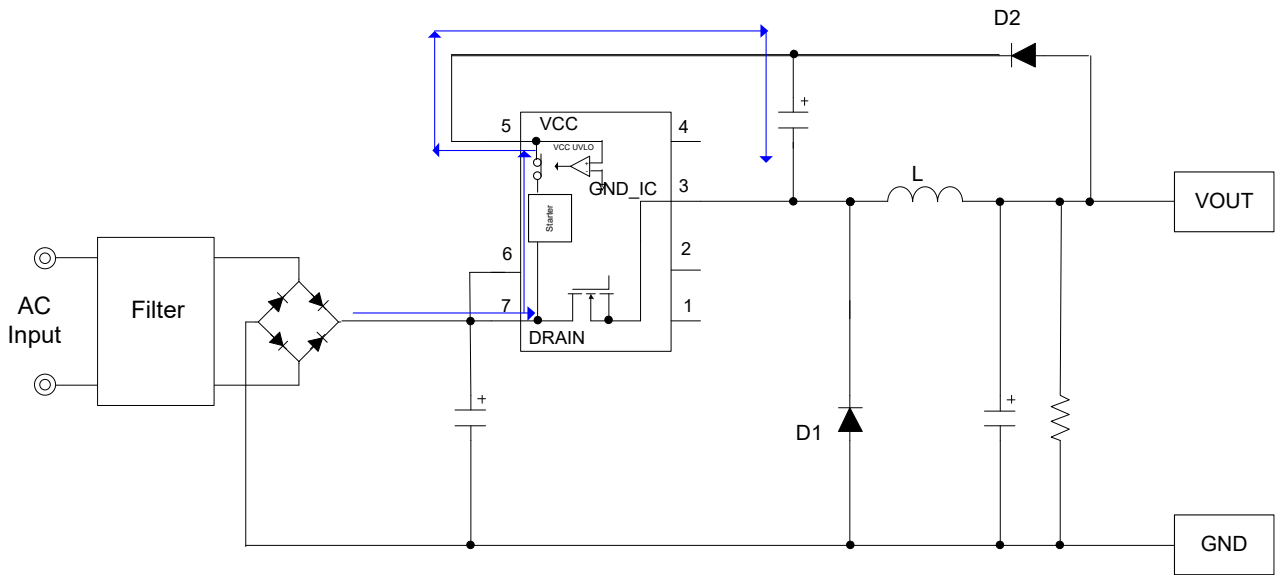

Figure 5. Start circuit

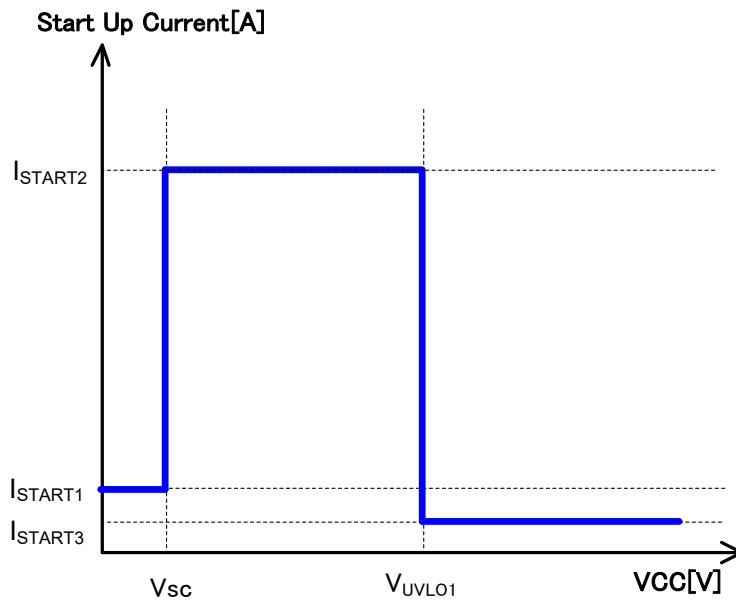

Figure 6. Start up current vs. VCC voltage

**(5) VCC pin protection function**

This IC has the internal protection function at the VCC pin shown in below.

- 1) Under voltage protection function UVLO (Under Voltage Locked Out)
- 2) Over voltage protection function VCC OVP (Over Voltage Protection)
- 3) VCC recharge function

**(5-1) VCC UVLO / VCC OVP function**

VCC UVLO function and VCC OVP function are auto recovery type comparators that have voltage hysteresis. VCC OVP has an internal mask time. If the condition that the VCC pin voltage is higher than  $V_{OVP1}$  lasts for  $T_{COMP}$  (100us typ.), it performs detection. The recovery requirements are that the VCC pin voltage is lower than  $V_{OVP2}$ .

**(5-2)VCC recharge function**

If the VCC pin drops to  $V_{CHG1}$  after once the VCC pin becomes more than  $V_{UVLO1}$  and the IC starts to operate, the VCC charge function operates. At that time, the VCC pin is charged from DRAIN pin through start circuit. When the VCC pin voltage raises to  $V_{CHG2}$  or above, charge is stopped.

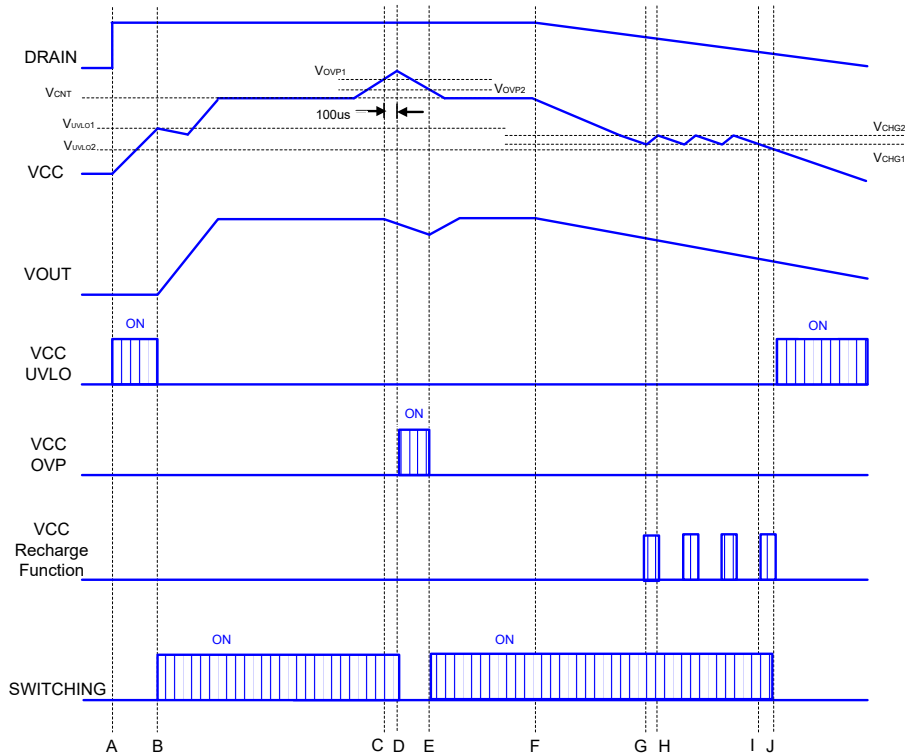

Figure 7. VCC UVLO / VCC OVP / VCC Recharge Function timing chart

- A: Input voltage is applied to the DRAIN pin and the VCC pin voltage rises.
- B: When the VCC pin voltage becomes higher than  $V_{UVLO1}$ , the IC starts operating. And if the IC judges the other protection functions as normal condition, it starts switching operation. The soft start function limits the over current limiter value to prevent any excessive voltage or current rising. When the switching operation starts, the V<sub>OUT</sub> rises.
- C: When the VCC pin voltage becomes higher than  $V_{OVP1}$ , VCC OVP timer operates.
- D: When the condition that the VCC pin voltage is higher than  $V_{OVP1}$  lasts for  $T_{LATCH}$  (typ=100us), the IC detects VCC OVP and stops switching.
- E: When the VCC pin voltage becomes higher than  $V_{OVP2}$ , VCC OVP is released.
- F: When the input power supply is turned OFF, the DRAIN pin voltage drops.
- G: When the VCC pin voltage becomes less than  $V_{CHG1}$ , recharge function is started.
- H: When the VCC pin voltage becomes higher than  $V_{CHG2}$ , recharge function is stopped.
- I: When the VCC pin voltage becomes lower than  $V_{CHG1}$ , recharge function is started. However the supply to the VCC pin decrease and the VCC pin voltage drops because of low DRAIN voltage.
- J: When the VCC pin voltage becomes lower than  $V_{UVLO2}$ , VCC UVLO function starts operating.

**(6) DC/DC driver**

This performs current mode PWM control. An internal oscillator sets a fixed switching frequency  $F_{sw}$  (typ=65kHz). This IC has a built-in switching frequency hopping function. The maximum duty is  $D_{max}$  (40% typ). To achieve the low consumption power at light load, it also has an internal burst mode circuit and a frequency reduction circuit.

**(6-1) Setting of the output voltage**

Adopting the non-isolated type without photo coupler, the VCC voltage should be set to rating value.

The VCC voltage means the voltage between the VCC pin and GND\_IC pin. The output voltage VOUT is defined by the formula below. The voltage when the MOSFET is OFF is shown in Figure 8.

$$V_{OUT} = V_{CNT} + V_{FD2} - V_{FD1}$$

VFD1: Forward voltage of diode D1    VFD2: Forward voltage of diode D2

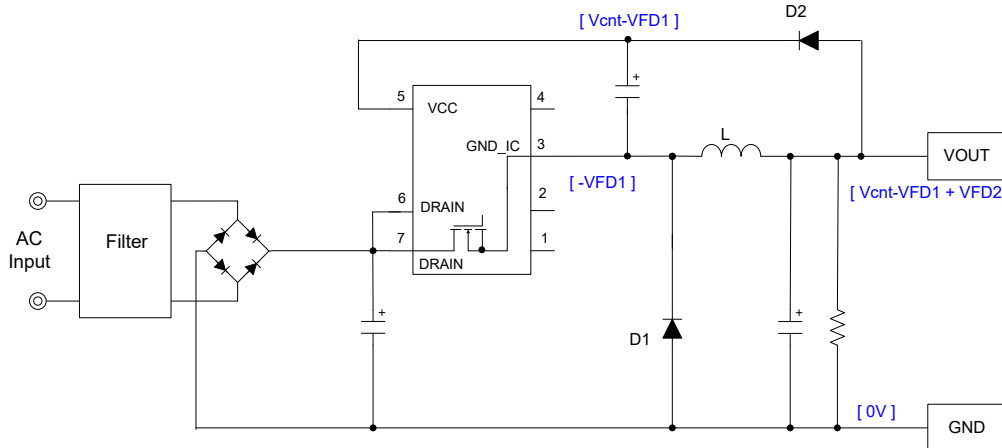

Figure 8. Back converter circuit (At MOSFET turned OFF)

At light load, the output voltage may rise because the VCC voltage is difference from the output voltage. In this case, it is necessary that the output pin is connected to resistor and the voltage should be lowered. The circuit diagram is shown in Figure 9.

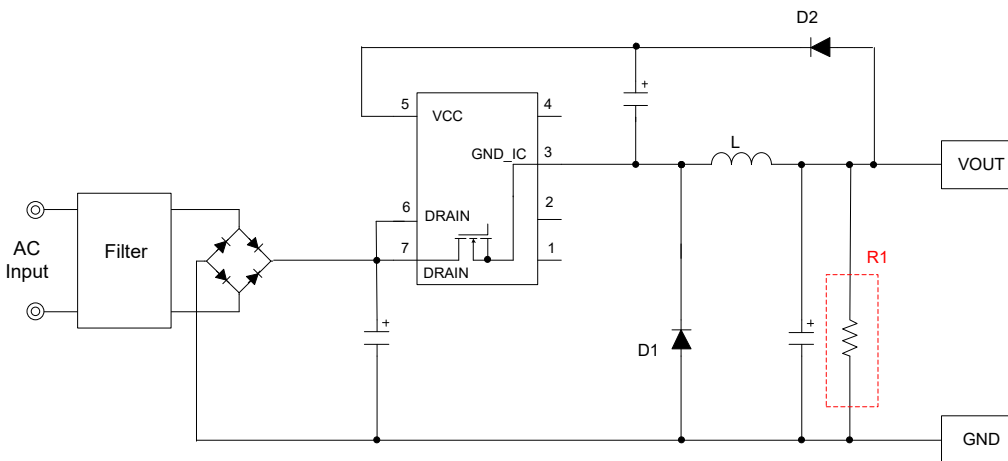

Figure 9. Voltage rising measure circuit at light load

This IC has a few external parts by fixing the VCC voltage and it enables simpler design. If you adjust the output voltage which is out of lineup, it can become the variable voltage by adding zener diodes. However it is necessary to consider the dispersion of the diodes.

The output voltage VOUT is defined by the formula below. The voltage when the MOSFET is OFF is shown in Figure 10.

$$V_{OUT} = V_{CNT} + V_{FD2} - V_{FD1} + V_{ZD1}$$

VFD1: Forward voltage of diode D1

VFD2: Forward voltage of diode D2

VZD1: Zener diode ZD1 voltage

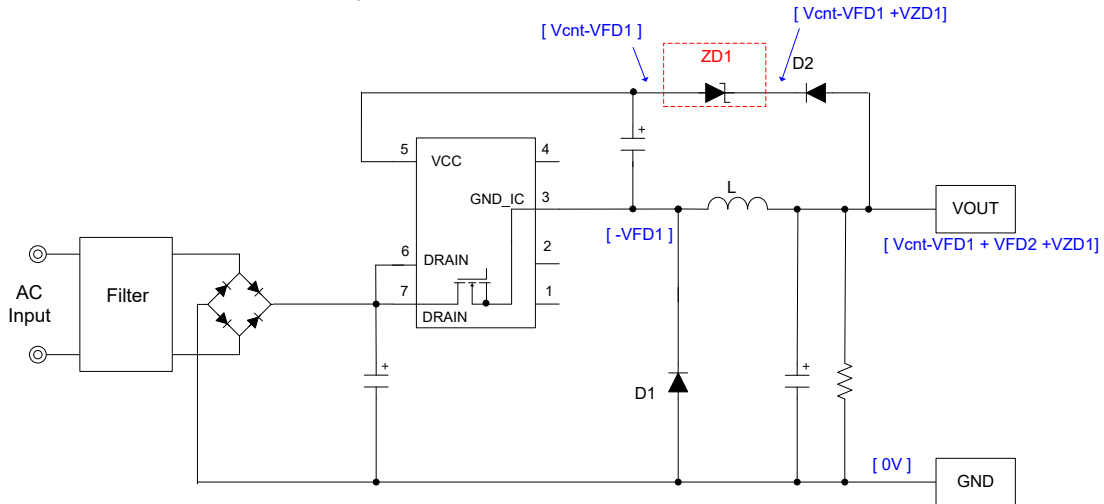

Figure 10. Back converter output dispersion circuit (MOSFET is OFF)

**(6-2) Frequency reduction circuit**

mode1: burst operation

mode2: frequency reduction operation (It reduces the frequency)

mode3: fixed frequency operation (It operates in max frequency)

mode4: over load operation (pulse operation is stopped and burst operation is started.)

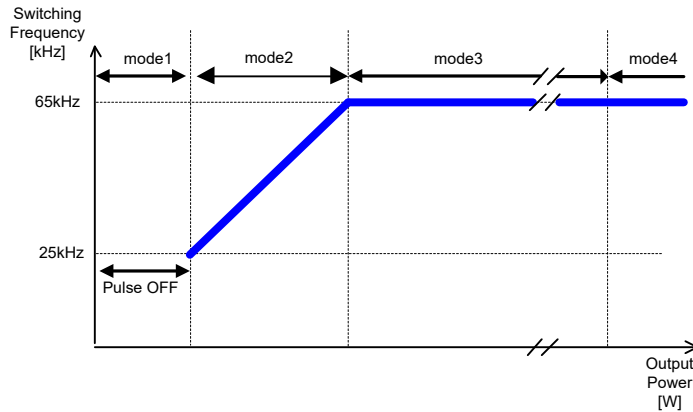

Figure 11. State transition of switching frequency

**(6-3) Frequency hopping function**

Frequency hopping function achieves low EMI by change the frequency at random. The wave width of frequency's upper limit is +6% for basic frequency,

**(6-4) PWM error amplifier and PWM comparator**

The internal error amplifier achieves the reduction of external parts. In addition, this IC adopts current mode method. It makes the design easy.

**(6-5) Over current limiter**

This IC has an internal over current limiter per switching cycle. This function monitors the coil current and if it exceeds a certain current, the IC stops switching. Additionally, an internal current detection resistor contributes to reduction of parts and improvement of efficiency. The peak current by which the IC switches to the over load mode is determined by the formula below.

$$\text{Peak current} = I_{PEAK} + (V_{DRAIN} - V_{OUT}) / L * T_{delay}$$

$I_{PEAK}$ : Over current limiter internal the IC

$V_{DRAIN}$ : DRAIN voltage

$V_{OUT}$ : Output voltage

$L$ : Coil value

$T_{delay}$ : Delay time after detection of over current limiter

**(6-6) Dynamic over current limiter**

This IC has a built-in dynamic over current limiter circuit. When the coil current exceeds  $I_{DPEAK1}$  (4.015A typ.) in succession twice, it stops pulse operation for  $T_{DPEAK}$  (128us typ.).

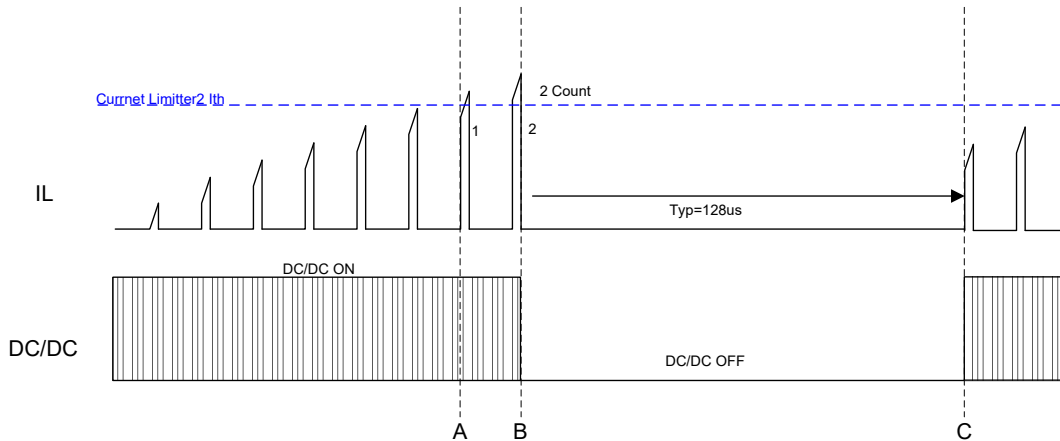

Figure 12. State transition of switching frequency

A: Normal operation

B: When the condition that IL is higher than  $I_{DPEAK1}$  is detected in succession twice, the IC stops DC/DC operation.

C: After  $T_{DPEAK}$  (typ=128us), the IC restarts DC/DC operation.

**(6-7) Soft start operation**

At starting up, this function controls the over current limiter value in order to prevent any excessive voltage or current rising. The details are shown in Figure 13. The IC enables the soft start operation by changing the over current limiter value with time.

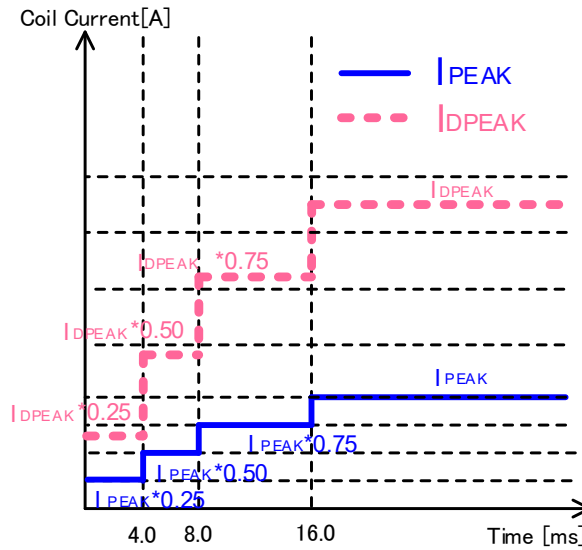

Figure 13. Soft start operation

**(7) Output over load protection function (OLP comparator)**

Output over protection function monitors load status and stops switching at over load. In the over load condition, the output voltage lowers, so the IC stops switching by judging the status as over load, if a state with more than of electric power set in the IC inside continues for  $T_{FOLP1}$  (64ms typ). The recovery after detection of FBOLP is  $T_{FOLP2}$  (512ms typ) later.

**(8) Temperature protection circuit**

Temperature protection circuit stops the oscillation of DC/DC if the IC becomes more than a certain temperature.

**Operation mode of protection circuits**

The operation mode of protection functions are shown in Table 1.

Table 1. The operation mode of protection functions

Function	VCC pin Under voltage protection	VCC pin Over voltage protection	Over temperature protection	Over power protection
Detection	7.30V (at rising voltage)	19.32V (at rising voltage)	150 °C (at rising temperature)	more than the current detected by over current detection
Release	8.80V (at falling voltage)	18.48 V (at falling voltage)	85 °C (at falling temperature)	under over current detection
Detection timer	-	100us	100us	64ms
Release timer	-	-	-	512ms
Type	Auto recovery	Auto recovery	Auto recovery	Auto recovery
Timer reset condition 1	-	VCC UVLO detection	VCC UVLO detection	VCC UVLO detection
Timer reset condition 2	-	<Detection> release condition <Release> detection condition	<Detection> release condition <Release> detection condition	<Detection> release condition <Release> detection condition

**Thermal loss**

The thermal design should set operation for the following conditions.

1. The ambient temperature  $T_a$  must be 105 °C or less.
2. The IC's loss must be within the allowable dissipation  $P_d$ .

The thermal abatement characteristics are as follows.  
 (PCB: 70mm×70mm×1.6mm mounted on glass epoxy substrate)

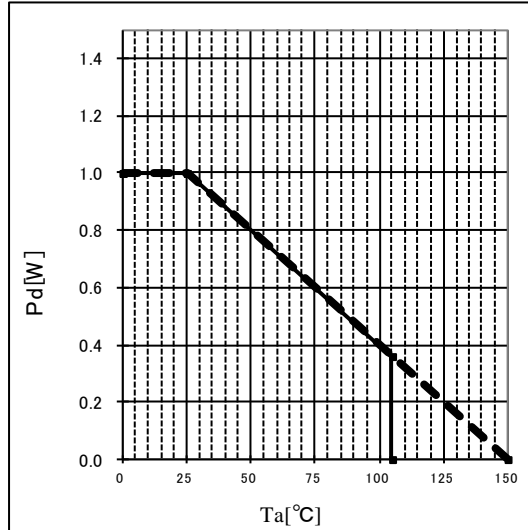

Figure 14. Thermal Abatement Characteristics

**I/O Equivalent Circuit Diagram**

7	DRAIN	6	DRAIN		5	VCC	
1	Non Connection	2	Non Connection	3	GND_IC	4	Non Connection

## Operational Notes

### 1. Reverse Connection of Power Supply

Connecting the power supply in reverse polarity can damage the IC. Take precautions against reverse polarity when connecting the power supply, such as mounting an external diode between the power supply and the IC's power supply pins.

### 2. Power Supply Lines

Design the PCB layout pattern to provide low impedance supply lines. Separate the ground and supply lines of the digital and analog blocks to prevent noise in the ground and supply lines of the digital block from affecting the analog block. Furthermore, connect a capacitor to ground at all power supply pins. Consider the effect of temperature and aging on the capacitance value when using electrolytic capacitors.

### 3. Ground Voltage

Ensure that no pins are at a voltage below that of the ground pin at any time, even during transient condition.

### 4. Ground Wiring Pattern

When using both small-signal and large-current ground traces, the two ground traces should be routed separately but connected to a single ground at the reference point of the application board to avoid fluctuations in the small-signal ground caused by large currents. Also ensure that the ground traces of external components do not cause variations on the ground voltage. The ground lines must be as short and thick as possible to reduce line impedance.

### 5. Thermal Consideration

Should by any chance the power dissipation rating be exceeded the rise in temperature of the chip may result in deterioration of the properties of the chip. The absolute maximum rating of the Pd stated in this specification is when the IC is mounted on a 70mm x 70mm x 1.6mm glass epoxy board. In case of exceeding this absolute maximum rating, increase the board size and copper area to prevent exceeding the Pd rating.

### 6. Recommended Operating Conditions

These conditions represent a range within which the expected characteristics of the IC can be approximately obtained. The electrical characteristics are guaranteed under the conditions of each parameter.

### 7. Inrush Current

When power is first supplied to the IC, it is possible that the internal logic may be unstable and inrush current may flow instantaneously due to the internal powering sequence and delays, especially if the IC has more than one power supply. Therefore, give special consideration to power coupling capacitance, power wiring, width of ground wiring, and routing of connections.

### 8. Operation Under Strong Electromagnetic Field

Operating the IC in the presence of a strong electromagnetic field may cause the IC to malfunction.

### 9. Testing on Application Boards

When testing the IC on an application board, connecting a capacitor directly to a low-impedance output pin may subject the IC to stress. Always discharge capacitors completely after each process or step. The IC's power supply should always be turned off completely before connecting or removing it from the test setup during the inspection process. To prevent damage from static discharge, ground the IC during assembly and use similar precautions during transport and storage.

### 10. Inter-pin Short and Mounting Errors

Ensure that the direction and position are correct when mounting the IC on the PCB. Incorrect mounting may result in damaging the IC. Avoid nearby pins being shorted to each other especially to ground, power supply and output pin. Inter-pin shorts could be due to many reasons such as metal particles, water droplets (in very humid environment) and unintentional solder bridge deposited in between pins during assembly to name a few.

Operational Notes – continued

11. Unused Input Pins

Input pins of an IC are often connected to the gate of a MOS transistor. The gate has extremely high impedance and extremely low capacitance. If left unconnected, the electric field from the outside can easily charge it. The small charge acquired in this way is enough to produce a significant effect on the conduction through the transistor and cause unexpected operation of the IC. So unless otherwise specified, unused input pins should be connected to the power supply or ground line.

12. Regarding the Input Pin of the IC

This monolithic IC contains P+ isolation and P substrate layers between adjacent elements in order to keep them isolated. P-N junctions are formed at the intersection of the P layers with the N layers of other elements, creating a parasitic diode or transistor. For example (refer to figure below):

When  $GND > Pin A$  and  $GND > Pin B$ , the P-N junction operates as a parasitic diode.  
 When  $GND > Pin B$ , the P-N junction operates as a parasitic transistor.

Parasitic diodes inevitably occur in the structure of the IC. The operation of parasitic diodes can result in mutual interference among circuits, operational faults, or physical damage. Therefore, conditions that cause these diodes to operate, such as applying a voltage lower than the GND voltage to an input pin (and thus to the P substrate) should be avoided.

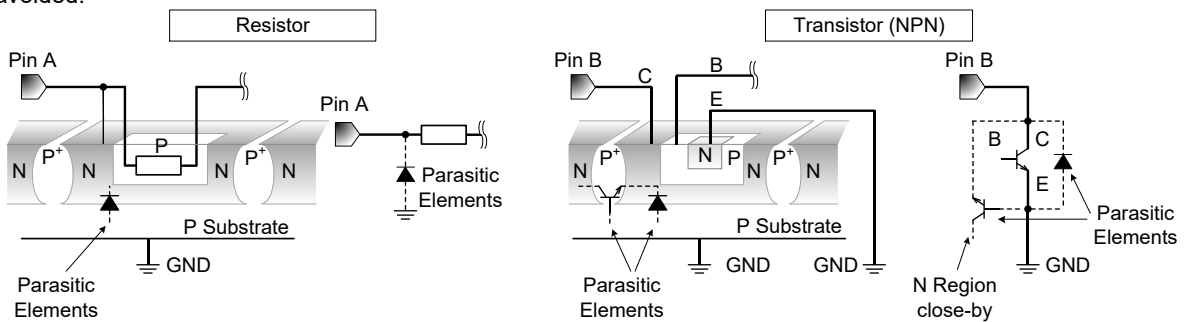

Figure Example of monolithic IC structure

13. Ceramic Capacitor

When using a ceramic capacitor, determine the dielectric constant considering the change of capacitance with temperature and the decrease in nominal capacitance due to DC bias and others.

14. Area of Safe Operation (ASO)

Operate the IC such that the output voltage, output current, and power dissipation are all within the Area of Safe Operation (ASO).

15. Thermal Shutdown Circuit(TSD)

This IC has a built-in thermal shutdown circuit that prevents heat damage to the IC. Normal operation should always be within the IC's power dissipation rating. If however the rating is exceeded for a continued period, the junction temperature ( $T_j$ ) will rise which will activate the TSD circuit that will turn OFF all output pins. The IC should be powered down and turned ON again to resume normal operation because the TSD circuit keeps the outputs at the OFF state even if the  $T_j$  falls below the TSD threshold.

Note that the TSD circuit operates in a situation that exceeds the absolute maximum ratings and therefore, under no circumstances, should the TSD circuit be used in a set design or for any purpose other than protecting the IC from heat damage.

16. Over Current Protection Circuit (OCP)

This IC incorporates an integrated overcurrent protection circuit that is activated when the load is shorted. This protection circuit is effective in preventing damage due to sudden and unexpected incidents. However, the IC should not be used in applications characterized by continuous operation or transitioning of the protection circuit.

Ordering Information

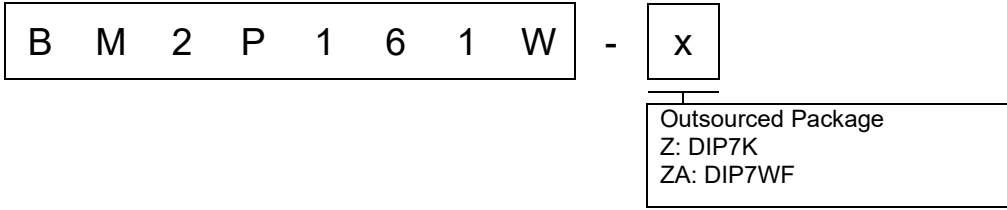

Making Diagram

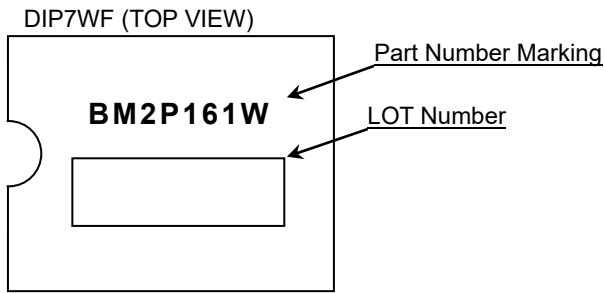
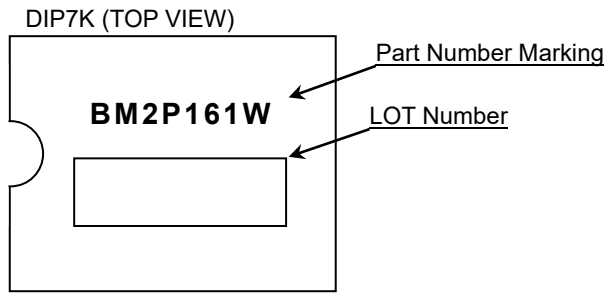

Physical Dimension and Packing Information

Package Name	DIP7K
--------------	-------

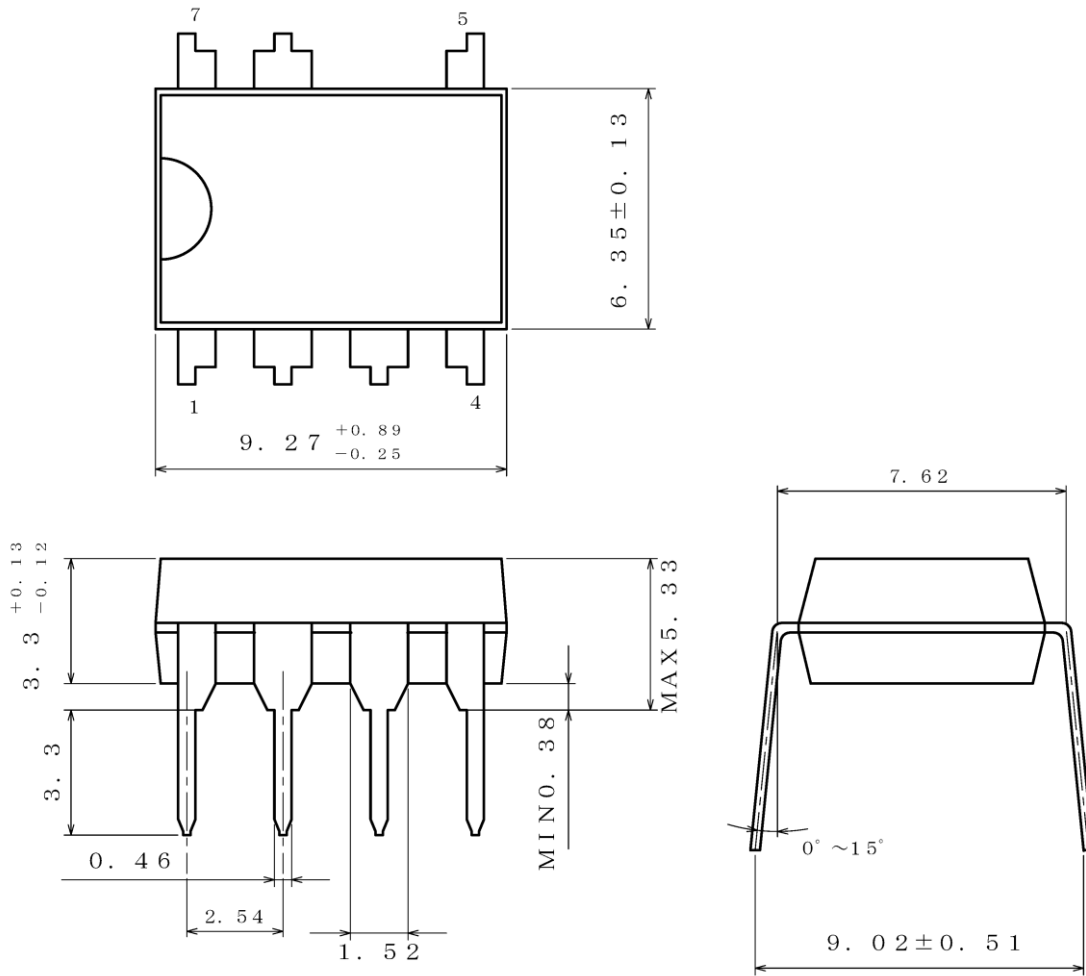

(UNIT : mm)  
 PKG : DIP7K  
 Drawing No. EX001-0076

< Container Information >

Container	Tube
Quantity	2000pcs
Direction of feed	Packing orientation is same in tube

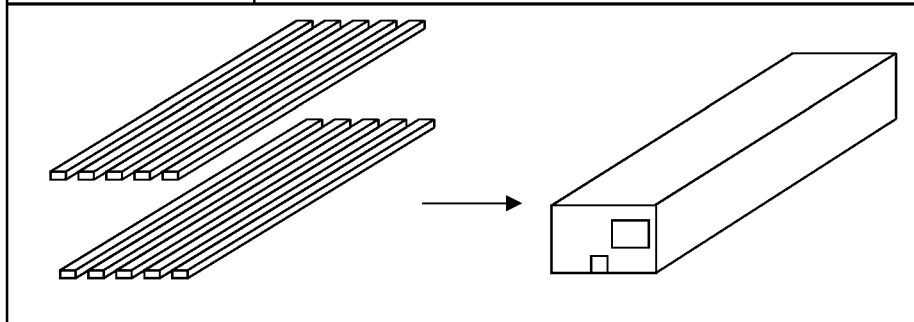

Physical Dimension and Packing Information

Package Name	DIP7WF
--------------	--------

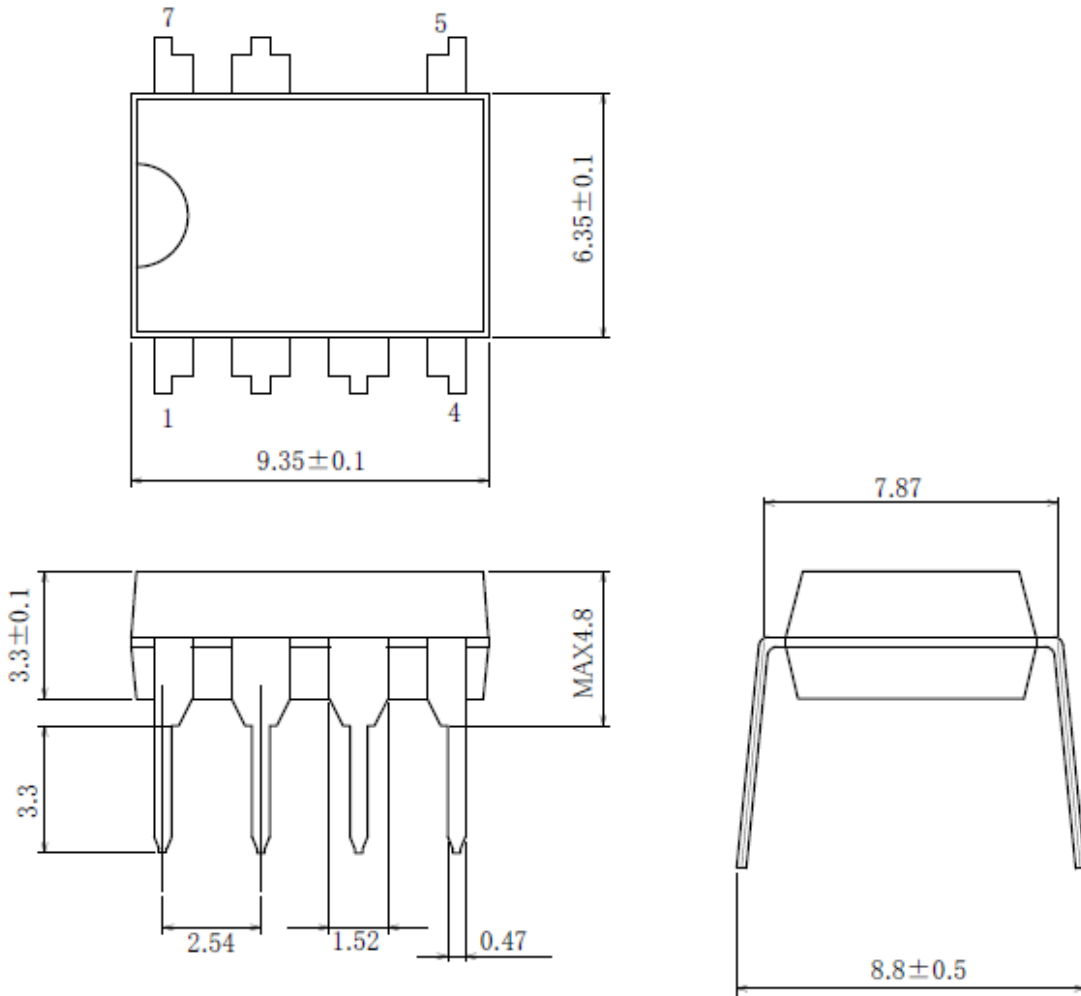

(UNIT:mm)

PKG:DIP7WF  
Drawing No.EX001-0120

< Container Information >

Container	Tube
Quantity	2000pcs
Direction of feed	Direction of products is fixed in a container tube

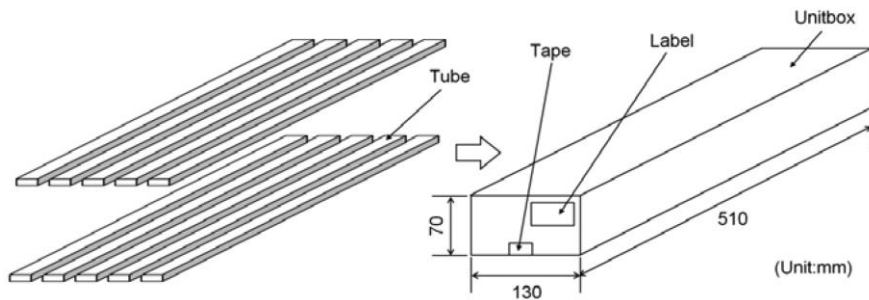

**Revision History**

date	Rev. NO.	Revision Point
11.Jul.2016	001	New release
19.Oct.2016	002	P3. Start Current1 limit change P4. Over current detection current limit change P4. Dynamic over current detection current limit change P12. Modify Dynamic over current limiter
22.Mar.2019	003	P1. Modify the figure and size of package P4. Add parameters to electrical characteristics P18. Modify the marking diagram P19. Modify the packing information
30.July.2019	004	Delete the product number (BM2P163W-Z)
26.Oct.2021	005	P1 Add the package variation P18 Add the package variation P20 Add the physical dimension

# Notice

## Precaution on using ROHM Products

- Our Products are designed and manufactured for application in ordinary electronic equipment (such as AV equipment, OA equipment, telecommunication equipment, home electronic appliances, amusement equipment, etc.). If you intend to use our Products in devices requiring extremely high reliability (such as medical equipment <sup>(Note 1)</sup>, transport equipment, traffic equipment, aircraft/spacecraft, nuclear power controllers, fuel controllers, car equipment including car accessories, safety devices, etc.) and whose malfunction or failure may cause loss of human life, bodily injury or serious damage to property ("Specific Applications"), please consult with the ROHM sales representative in advance. Unless otherwise agreed in writing by ROHM in advance, ROHM shall not be in any way responsible or liable for any damages, expenses or losses incurred by you or third parties arising from the use of any ROHM's Products for Specific Applications.

(Note1) Medical Equipment Classification of the Specific Applications

JAPAN	USA	EU	CHINA
CLASS III	CLASS III	CLASS II b	CLASS III
CLASS IV		CLASS III	

- ROHM designs and manufactures its Products subject to strict quality control system. However, semiconductor products can fail or malfunction at a certain rate. Please be sure to implement, at your own responsibilities, adequate safety measures including but not limited to fail-safe design against the physical injury, damage to any property, which a failure or malfunction of our Products may cause. The following are examples of safety measures:
  - Installation of protection circuits or other protective devices to improve system safety
  - Installation of redundant circuits to reduce the impact of single or multiple circuit failure
- Our Products are designed and manufactured for use under standard conditions and not under any special or extraordinary environments or conditions, as exemplified below. Accordingly, ROHM shall not be in any way responsible or liable for any damages, expenses or losses arising from the use of any ROHM's Products under any special or extraordinary environments or conditions. If you intend to use our Products under any special or extraordinary environments or conditions (as exemplified below), your independent verification and confirmation of product performance, reliability, etc. prior to use, must be necessary:
  - Use of our Products in any types of liquid, including water, oils, chemicals, and organic solvents
  - Use of our Products outdoors or in places where the Products are exposed to direct sunlight or dust
  - Use of our Products in places where the Products are exposed to sea wind or corrosive gases, including Cl<sub>2</sub>, H<sub>2</sub>S, NH<sub>3</sub>, SO<sub>2</sub>, and NO<sub>2</sub>
  - Use of our Products in places where the Products are exposed to static electricity or electromagnetic waves
  - Use of our Products in proximity to heat-producing components, plastic cords, or other flammable items
  - Sealing or coating our Products with resin or other coating materials
  - Use of our Products without cleaning residue of flux (Exclude cases where no-clean type fluxes is used. However, recommend sufficiently about the residue.) ; or Washing our Products by using water or water-soluble cleaning agents for cleaning residue after soldering
  - Use of the Products in places subject to dew condensation
- The Products are not subject to radiation-proof design.
- Please verify and confirm characteristics of the final or mounted products in using the Products.
- In particular, if a transient load (a large amount of load applied in a short period of time, such as pulse, is applied, confirmation of performance characteristics after on-board mounting is strongly recommended. Avoid applying power exceeding normal rated power; exceeding the power rating under steady-state loading condition may negatively affect product performance and reliability.
- De-rate Power Dissipation depending on ambient temperature. When used in sealed area, confirm that it is the use in the range that does not exceed the maximum junction temperature.
- Confirm that operation temperature is within the specified range described in the product specification.
- ROHM shall not be in any way responsible or liable for failure induced under deviant condition from what is defined in this document.

## Precaution for Mounting / Circuit board design

- When a highly active halogenous (chlorine, bromine, etc.) flux is used, the residue of flux may negatively affect product performance and reliability.
- In principle, the reflow soldering method must be used on a surface-mount products, the flow soldering method must be used on a through hole mount products. If the flow soldering method is preferred on a surface-mount products, please consult with the ROHM representative in advance.

For details, please refer to ROHM Mounting specification

### Precautions Regarding Application Examples and External Circuits

1. If change is made to the constant of an external circuit, please allow a sufficient margin considering variations of the characteristics of the Products and external components, including transient characteristics, as well as static characteristics.
2. You agree that application notes, reference designs, and associated data and information contained in this document are presented only as guidance for Products use. Therefore, in case you use such information, you are solely responsible for it and you must exercise your own independent verification and judgment in the use of such information contained in this document. ROHM shall not be in any way responsible or liable for any damages, expenses or losses incurred by you or third parties arising from the use of such information.

### Precaution for Electrostatic

This Product is electrostatic sensitive product, which may be damaged due to electrostatic discharge. Please take proper caution in your manufacturing process and storage so that voltage exceeding the Products maximum rating will not be applied to Products. Please take special care under dry condition (e.g. Grounding of human body / equipment / solder iron, isolation from charged objects, setting of Ionizer, friction prevention and temperature / humidity control).

### Precaution for Storage / Transportation

1. Product performance and soldered connections may deteriorate if the Products are stored in the places where:
  - [a] the Products are exposed to sea winds or corrosive gases, including Cl<sub>2</sub>, H<sub>2</sub>S, NH<sub>3</sub>, SO<sub>2</sub>, and NO<sub>2</sub>
  - [b] the temperature or humidity exceeds those recommended by ROHM
  - [c] the Products are exposed to direct sunshine or condensation
  - [d] the Products are exposed to high Electrostatic
2. Even under ROHM recommended storage condition, solderability of products out of recommended storage time period may be degraded. It is strongly recommended to confirm solderability before using Products of which storage time is exceeding the recommended storage time period.
3. Store / transport cartons in the correct direction, which is indicated on a carton with a symbol. Otherwise bent leads may occur due to excessive stress applied when dropping of a carton.
4. Use Products within the specified time after opening a humidity barrier bag. Baking is required before using Products of which storage time is exceeding the recommended storage time period.

### Precaution for Product Label

A two-dimensional barcode printed on ROHM Products label is for ROHM's internal use only.

### Precaution for Disposition

When disposing Products please dispose them properly using an authorized industry waste company.

### Precaution for Foreign Exchange and Foreign Trade act

Since concerned goods might be fallen under listed items of export control prescribed by Foreign exchange and Foreign trade act, please consult with ROHM in case of export.

### Precaution Regarding Intellectual Property Rights

1. All information and data including but not limited to application example contained in this document is for reference only. ROHM does not warrant that foregoing information or data will not infringe any intellectual property rights or any other rights of any third party regarding such information or data.
2. ROHM shall not have any obligations where the claims, actions or demands arising from the combination of the Products with other articles such as components, circuits, systems or external equipment (including software).
3. No license, expressly or implied, is granted hereby under any intellectual property rights or other rights of ROHM or any third parties with respect to the Products or the information contained in this document. Provided, however, that ROHM will not assert its intellectual property rights or other rights against you or your customers to the extent necessary to manufacture or sell products containing the Products, subject to the terms and conditions herein.

### Other Precaution



1. This document may not be reprinted or reproduced, in whole or in part, without prior written consent of ROHM.
2. The Products may not be disassembled, converted, modified, reproduced or otherwise changed without prior written consent of ROHM.
3. In no event shall you use in any way whatsoever the Products and the related technical information contained in the Products or this document for any military purposes, including but not limited to, the development of mass-destruction weapons.
4. The proper names of companies or products described in this document are trademarks or registered trademarks of ROHM, its affiliated companies or third parties.

**General Precaution**

1. Before you use our Products, you are requested to carefully read this document and fully understand its contents. ROHM shall not be in any way responsible or liable for failure, malfunction or accident arising from the use of any ROHM's Products against warning, caution or note contained in this document.
2. All information contained in this document is current as of the issuing date and subject to change without any prior notice. Before purchasing or using ROHM's Products, please confirm the latest information with a ROHM sales representative.
3. The information contained in this document is provided on an "as is" basis and ROHM does not warrant that all information contained in this document is accurate and/or error-free. ROHM shall not be in any way responsible or liable for any damages, expenses or losses incurred by you or third parties resulting from inaccuracy or errors of or concerning such information.

## Looking for pricing, stock, or lifecycle information?

Click below to explore more details on WIN SOURCE:

-  [View BM2P161W-Z on WIN SOURCE](#)
-  [Rohm Semiconductor](#) Information

## Optimize Your Supply Chain with WIN SOURCE Solutions

-  Global Sourcing Solution
-  Obsolete Management
-  Cost Control Management
-  Shortage Management
-  Alternative Solution
-  Excess Inventory Management