



**THE DATASHEET OF  
AD9551BCPZ**



### FEATURES

- Translation between any two standard network rates**
- Dual reference inputs and dual clock outputs**
- Pin programmable for standard network rate translation**
- SPI programmable for arbitrary rational rate translation**
- Output frequencies from 10 MHz to 900 MHz**
- Input frequencies from 19.44 MHz to 806 MHz**
- On-chip VCO**
- Meets OC-192 high band jitter generation requirement**
- Supports standard forward error correction (FEC) rates**
- Supports holdover operation**
- Supports hitless switchover and phase build-out (even with unequal reference frequencies)**
- SPI-compatible 3-wire programming interface**
- Single supply (3.3 V)**

### APPLICATIONS

- Multiservice switches**
- Multiservice routers**
- Exact network clock frequency translation**
- General-purpose frequency translation**

### GENERAL DESCRIPTION

The AD9551 accepts one or two reference input signals to synthesize one or two output signals. The AD9551 uses a fractional-N PLL that precisely translates the reference frequency to the desired output frequency. The input receivers and output drivers provide both single-ended and differential operation.

Reference conditioning and switchover circuitry internally synchronizes the two references so that if one reference fails, there is virtually no phase perturbation at the output.

The AD9551 uses an external crystal and an internal DCXO to provide for holdover operation. If both references fail, the device maintains a steady output signal.

The AD9551 provides pin-selectable, preset divider values for standard (and FEC adjusted) network frequencies. The pin-selectable frequencies include any combination of 15 possible input frequencies and 16 possible output frequencies. A SPI interface provides further flexibility by making it possible to program almost any rational input/output frequency ratio.

The AD9551 is a clock generator that employs fractional-N-based phase-locked loops (PLL) using sigma-delta ( $\Sigma$ - $\Delta$ ) modulators (SDMs). The fractional frequency synthesis capability enables the device to meet the frequency and feature requirements for multiservice switch applications. The AD9551 precisely generates a wide range of standard frequencies when using any one of those same standard frequencies as a timing base (reference). The primary challenge of this function is the precise generation of the desired output frequency because even a slight output frequency error can cause problems for downstream clocking circuits in the form of bit or cycle slips. The requirement for exact frequency translation in such applications necessitates the use of a fractional-N-based PLL architecture with variable modulus.

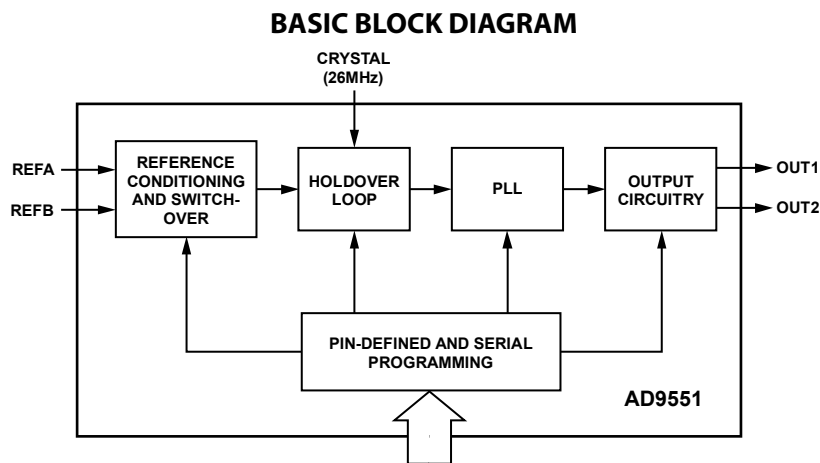

Figure 1.

07865-001

#### Rev. B

Information furnished by Analog Devices is believed to be accurate and reliable. However, no responsibility is assumed by Analog Devices for its use, nor for any infringements of patents or other rights of third parties that may result from its use. Specifications subject to change without notice. No license is granted by implication or otherwise under any patent or patent rights of Analog Devices. Trademarks and registered trademarks are the property of their respective owners.

**TABLE OF CONTENTS**

Features .....	1	Theory of Operation .....	16
Applications.....	1	Operating Modes.....	16
General Description .....	1	Component Blocks.....	16
Basic Block Diagram .....	1	Holdover Mode.....	21
Revision History .....	2	Jitter Tolerance.....	21
Functional Block Diagram .....	3	External Loop Filter Capacitor .....	21
Specifications.....	4	Output/Input Frequency Relationship .....	21
Reference Clock Input Characteristics .....	4	Calculating Divider Values .....	22
Output Characteristics.....	4	Low Dropout (LDO) Regulators .....	24
Jitter Characteristics (180 Hz Loop Bandwidth).....	5	Applications Information .....	25
Crystal Oscillator Characteristics.....	5	Thermal Performance.....	25
Power Consumption .....	5	Serial Control Port .....	26
Logic Input Pins.....	6	Serial Control Port Pin Descriptions.....	26
RESET Pin .....	6	Operation of the Serial Control Port .....	26
Logic Output Pins.....	6	Instruction Word (16 Bits).....	27
Serial Control Port .....	6	MSB/LSB First Transfers .....	27
Serial Control Port Timing .....	7	Register Map .....	29
Absolute Maximum Ratings.....	8	Register Map Descriptions.....	32
ESD Caution.....	8	Outline Dimensions .....	40
Pin Configuration and Function Descriptions.....	9	Ordering Guide .....	40
Typical Performance Characteristics .....	11		
Preset Frequency Ratios.....	14		

**REVISION HISTORY****9/09—Rev. A to Rev. B**

Changes to Table 25.....	33
--------------------------	----

**6/09—Rev. 0 to Rev. A**

Changes to Figure 23.....	23
---------------------------	----

**4/09—Revision 0: Initial Version**

The AD9551 is easily configured using the external control pins (A[3:0], B[3:0], and Y[3:0]). The logic state of these pins sets pre-defined divider values that establish a specific input-to-output frequency ratio. For applications requiring other frequency ratios, the user can override any of the preconfigured divider settings via the serial port, which enables a very wide range of applications.

The AD9551 architecture consists of two cascaded PLL stages. The first stage consists of fractional division (via SDM), followed by a digital PLL that uses a crystal resonator-based DCXO. The DCXO relies on an external crystal with a resonant frequency in the range of 19.44 MHz to 52 MHz. The DCXO constitutes the first PLL, which operates within a narrow frequency range ( $\pm 50$  ppm) around the crystal resonant frequency. This PLL has a loop bandwidth of approximately 180 Hz, providing initial jitter cleanup of the input reference signal. The second stage is a frequency multiplying PLL that translates the first stage output frequency (in the range of 19.44 MHz to 104 MHz) up to  $\sim 3.7$  GHz. This PLL incorporates an SDM-based fractional feedback divider that enables fractional frequency multiplication. Programmable integer dividers at the output of this second PLL establish a final output frequency of up to 900 MHz.

It is important to understand that the architecture of the AD9551 produces an output frequency that is most likely not coherent with the input reference frequency. The reason is that the input and crystal frequencies typically are not harmonically related and neither are the output and crystal frequencies. As a result, there is generally no relationship between the phase of the input and output signals.

The AD9551 includes reference signal processing blocks that enable a smooth switching transition between two reference inputs. This circuitry automatically detects the presence of the reference input signals. If only one input is present, the device uses it as the active reference. If both inputs are present, one becomes the active reference and the other becomes the alternate reference. The circuitry edge-aligns the backup reference with the active reference. If the active reference fails, the circuitry automatically switches to the backup reference (if available), making it the new active reference. Meanwhile, if the failed reference is once again available, it becomes the new backup reference and is edge-aligned with the new active reference (a precaution against failure of the new active reference).

If neither reference can be used, the AD9551 supports a holdover mode. Note that the external crystal is necessary to provide the switchover and holdover functionality. It is also the clock source for the reference synchronization and monitoring functions.

The AD9551 relies on a single external capacitor for the output PLL loop filter. With proper termination, the output is compatible with LVPECL, LVDS, or CMOS logic levels, although the AD9551 is implemented in a strictly CMOS process.

The AD9551 operates over the extended industrial temperature range of  $-40^{\circ}\text{C}$  to  $+85^{\circ}\text{C}$ .

## FUNCTIONAL BLOCK DIAGRAM

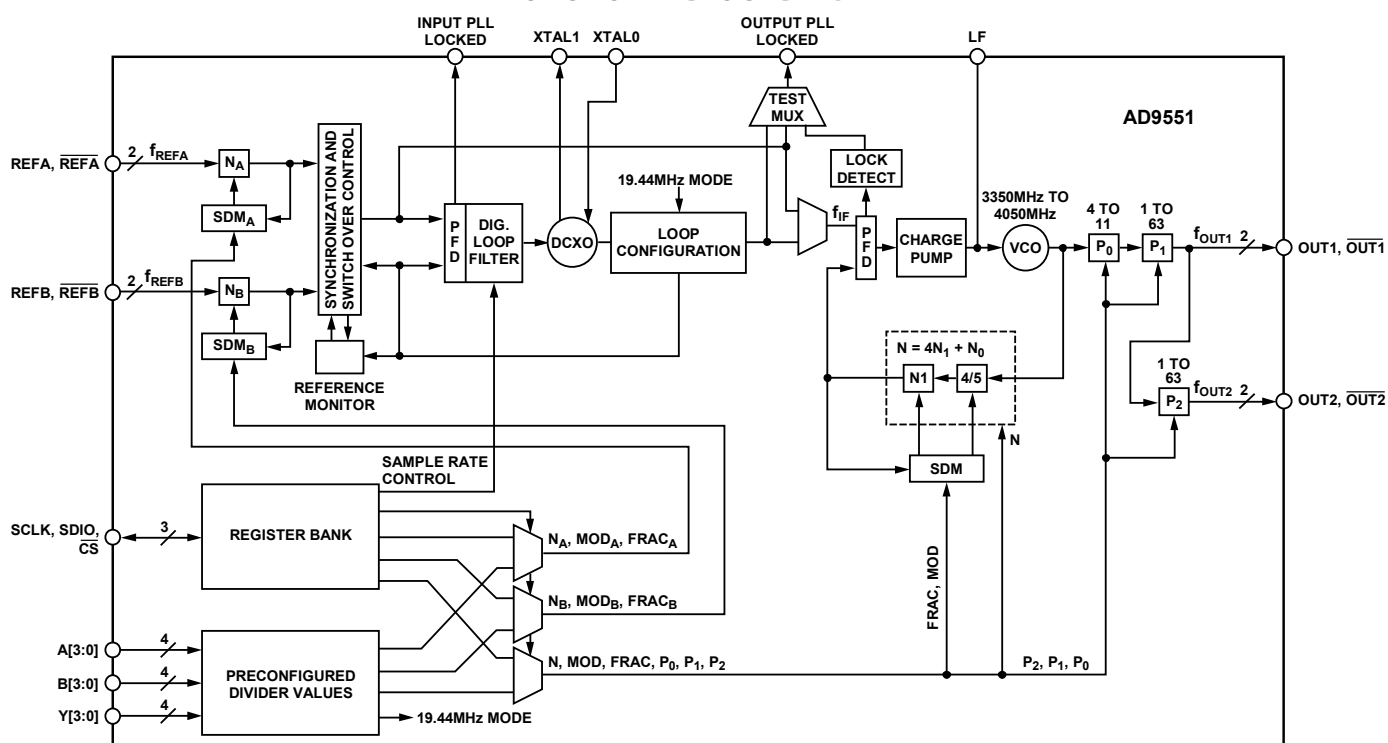

Figure 2.

# AD9551

## SPECIFICATIONS

Minimum and maximum values apply for full range of supply voltage and operating temperature variation. Typical values apply for  $V_{DD} = 3.3\text{ V}$ ,  $T_A = 25^\circ\text{C}$ , unless otherwise noted.

### REFERENCE CLOCK INPUT CHARACTERISTICS

Table 1.

Parameter	Min	Typ	Max	Unit	Test Conditions/Comments
FREQUENCY RANGE	19 <sup>1</sup>		806	MHz	
INPUT CAPACITANCE		3		pF	
INPUT RESISTANCE		6		k $\Omega$	Measured single-ended
DUTY CYCLE	40		60	%	
REFERENCE CLOCK INPUT VOLTAGE SWING					Measured with a differential probe across the input pins
Differential	250			mV	Maximum magnitude across pin pair
Single-Ended	250			mV	Peak-to-peak

<sup>1</sup> The 19 MHz lower limit applies only to the 19.44 MHz operating mode.

### OUTPUT CHARACTERISTICS

Table 2.

Parameter	Min	Typ	Max	Unit	Test Conditions/Comments
LVPECL MODE					
Differential Output Voltage Swing	690	765	889	mV	Output driver static
Common-Mode Output Voltage	$V_{DD} - 1.77$	$V_{DD} - 1.66$	$V_{DD} - 1.20$	V	Output driver static
Frequency Range	0		900	MHz	
Duty Cycle	40		60	%	Up to 805 MHz output frequency
Rise/Fall Time <sup>1</sup> (20% to 80%)		255	305	ps	100 $\Omega$ termination between both pins of the output driver
LVDS MODE					
Differential Output Voltage Swing					
Balanced, $V_{OD}$	247		454	mV	Voltage swing between output pins; output driver static
Unbalanced, $\Delta V_{OD}$			25	mV	Absolute difference between voltage swing of normal pin and inverted pin; output driver static
Offset Voltage					
Common Mode, $V_{OS}$	1.125		1.375	V	Output driver static
Common-Mode Difference, $\Delta V_{OS}$			25	mV	Voltage difference between output pins; output driver static
Short-Circuit Output Current		17	24	mA	
Frequency Range	0		900	MHz	
Duty Cycle	40		60	%	Up to 805 MHz output frequency
Rise/Fall Time <sup>1</sup> (20% to 80%)		285	355	ps	100 $\Omega$ termination between both pins of the output driver
CMOS MODE					
Output Voltage High, $V_{OH}$					Output driver static; standard drive strength setting
$I_{OH} = 10\text{ mA}$	2.8			V	
$I_{OH} = 1\text{ mA}$	2.8			V	
Output Voltage Low, $V_{OL}$					Output driver static; standard drive strength setting
$I_{OL} = 10\text{ mA}$			0.5	V	
$I_{OL} = 1\text{ mA}$			0.3	V	
Frequency Range	0		200	MHz	3.3 V CMOS; standard drive strength setting

Parameter	Min	Typ	Max	Unit	Test Conditions/Comments
Duty Cycle	45		55	%	At maximum output frequency 3.3 V CMOS; standard drive strength setting; 10 pF load
Rise/Fall Time <sup>1</sup> (20% to 80%)		500	745	ps	

<sup>1</sup> The listed values are for the slower edge (rise or fall).

### JITTER CHARACTERISTICS (180 HZ LOOP BANDWIDTH)

Table 3.

Parameter	Min	Typ	Max	Unit	Test Conditions/Comments
JITTER GENERATION					
12 kHz to 20 MHz		1.3		ps rms	$f_{IN} = 19.44$ MHz, $f_{OUT} = 622.08$ MHz
		0.8		ps rms	$f_{IN} = 622.08$ MHz, $f_{OUT} = 622.08$ MHz
50 kHz to 80 MHz		0.5		ps rms	$f_{IN} = 19.44$ MHz, $f_{OUT} = 622.08$ MHz
		0.6		ps rms	$f_{IN} = 622.08$ MHz, $f_{OUT} = 622.08$ MHz
4 MHz to 80 MHz		0.1		ps rms	$f_{IN} = 622.08$ MHz, $f_{OUT} = 622.08$ MHz
JITTER TRANSFER BANDWIDTH		180		Hz	See the Typical Performance Characteristics section
JITTER TRANSFER PEAKING		0.1		dB	See the Typical Performance Characteristics section

### CRYSTAL OSCILLATOR CHARACTERISTICS

Table 4.

Parameter	Min	Typ	Max	Unit	Test Conditions/Comments
CRYSTAL FREQUENCY					
Range	19	26	52	MHz	
Tolerance			20	ppm	
CRYSTAL MOTIONAL RESISTANCE			100	$\Omega$	
DCXO LOAD CAPACITANCE CONTROL RANGE		3 to 21		pF	Requires a crystal with a 10 pF load specification

### POWER CONSUMPTION

Table 5.

Parameter	Min	Typ	Max	Unit	Test Conditions/Comments
TOTAL CURRENT		169	195	mA	At maximum output frequency with both output channels active
VDD CURRENT BY PIN					
Pin 9		24	27	mA	
Pin 23		78	84	mA	
Pin 27		36	42	mA	
Pin 34		36	42	mA	
LVPECL OUTPUT DRIVER		38		mA	900 MHz with 100 $\Omega$ termination between both pins of the output driver

# AD9551

## LOGIC INPUT PINS

Table 6.

Parameter	Min	Typ	Max	Unit	Test Conditions/Comments
INPUT CHARACTERISTICS <sup>1</sup>					
Logic 1 Voltage, $V_{IH}$	1.0			V	For the CMOS inputs, a static Logic 1 results from either a pull-up resistor or no connection
Logic 0 Voltage, $V_{IL}$			0.8	V	
Logic 1 Current, $I_{IH}$			3	$\mu\text{A}$	
Logic 0 Current, $I_{IL}$			17	$\mu\text{A}$	

<sup>1</sup> The A[3:0], B[3:0], Y[3:0], and OUTSEL pins have 100 k $\Omega$  internal pull-up resistors.

## RESET PIN

Table 7.

Parameter	Min	Typ	Max	Unit
INPUT CHARACTERISTICS <sup>1</sup>				
Input Voltage High, $V_{IH}$	1.8			V
Input Voltage Low, $V_{IL}$			1.3	V
Input Current High, $I_{INH}$		0.3	12.5	$\mu\text{A}$
Input Current Low, $I_{INL}$		31	43	$\mu\text{A}$
MINIMUM PULSE WIDTH HIGH	2			ns

<sup>1</sup> The RESET pin has a 100 k $\Omega$  internal pull-up resistor, so the default state of the device is reset.

## LOGIC OUTPUT PINS

Table 8.

Parameter	Min	Typ	Max	Unit
OUTPUT CHARACTERISTICS				
Output Voltage High, $V_{OH}$	2.7			V
Output Voltage Low, $V_{OL}$			0.4	V

## SERIAL CONTROL PORT

Table 9.

Parameter	Min	Typ	Max	Unit	Test Conditions/Comments
$\overline{\text{CS}}$					
Input Logic 1 Voltage	1.6			V	
Input Logic 0 Voltage			0.5	V	
Input Logic 1 Current			0.03	$\mu\text{A}$	
Input Logic 0 Current		2		$\mu\text{A}$	
Input Capacitance		2		pF	
SCLK					
Input Logic 1 Voltage	1.6			V	
Input Logic 0 Voltage			0.5	V	
Input Logic 1 Current		2		$\mu\text{A}$	
Input Logic 0 Current			0.03	$\mu\text{A}$	
Input Capacitance		2		pF	
SDIO					
Input					
Input Logic 1 Voltage	1.6			V	
Input Logic 0 Voltage			0.5	V	

Parameter	Min	Typ	Max	Unit	Test Conditions/Comments
Input Logic 1 Current		1		$\mu\text{A}$	
Input Logic 0 Current		1		$\mu\text{A}$	
Input Capacitance		2		pF	
Output					
Output Logic 1 Voltage	2.8			V	1 mA load current
Output Logic 0 Voltage			0.3	V	1 mA load current

## SERIAL CONTROL PORT TIMING

Table 10.

Parameter	Limit	Unit
SCLK		
Clock Rate, $1/t_{\text{CLK}}$	50	MHz max
Pulse Width High, $t_{\text{HIGH}}$	3	ns min
Pulse Width Low, $t_{\text{LOW}}$	3	ns min
SDIO to SCLK Setup, $t_{\text{DS}}$	4	ns min
SCLK to SDIO Hold, $t_{\text{DH}}$	0	ns min
SCLK to Valid SDIO, $t_{\text{DV}}$	13	ns max
$\overline{\text{CS}}$ to SCLK Setup ( $t_{\text{S}}$ ) and Hold ( $t_{\text{H}}$ )	0	ns min
$\overline{\text{CS}}$ Minimum Pulse Width High	6.4	ns min

## ABSOLUTE MAXIMUM RATINGS

Table 11.

Parameter	Rating
Supply Voltage (VDD)	3.6 V
Maximum Digital Input Voltage	-0.5 V to VDD + 0.5 V
Storage Temperature	-65°C to +150°C
Operating Temperature Range	-40°C to +85°C
Lead Temperature (Soldering, 10 sec)	300°C
Junction Temperature	150°C

Stresses above those listed under Absolute Maximum Ratings may cause permanent damage to the device. This is a stress rating only; functional operation of the device at these or any other conditions above those indicated in the operational section of this specification is not implied. Exposure to absolute maximum rating conditions for extended periods may affect device reliability.

### ESD CAUTION



**ESD (electrostatic discharge) sensitive device.**

Charged devices and circuit boards can discharge without detection. Although this product features patented or proprietary protection circuitry, damage may occur on devices subjected to high energy ESD. Therefore, proper ESD precautions should be taken to avoid performance degradation or loss of functionality.

## PIN CONFIGURATION AND FUNCTION DESCRIPTIONS

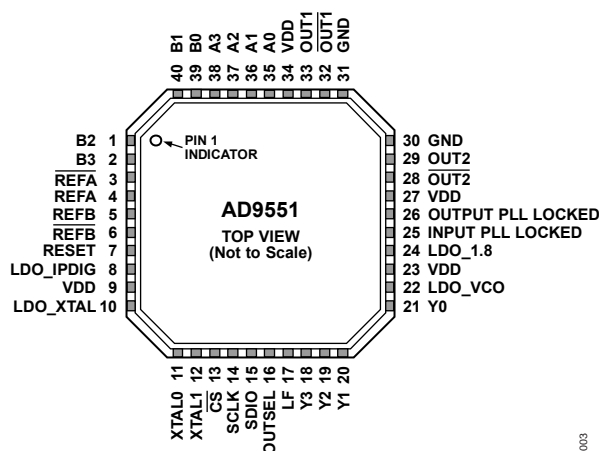

NOTES  
1. EXPOSED DIE PAD MUST BE CONNECTED TO GND.

07805-003

Figure 3. Pin Configuration

Table 12. Pin Function Descriptions

Pin No.	Mnemonic	Type <sup>1</sup>	Description
9, 23, 27, 34	VDD	P	Power Supply Connection (3.3 V Analog Supply).
30, 31	GND	P	Analog Ground.
4	REFA	I	Analog Input (Active High)—Reference Clock Input A.
3	$\overline{\text{REFA}}$	I	Analog Input (Active High)—Complementary Reference Clock Input A.
5	REFB	I	Analog Input (Active High)—Reference Clock Input B.
6	$\overline{\text{REFB}}$	I	Analog Input (Active High)—Complementary Reference Clock Input B.
13	$\overline{\text{CS}}$	I	Digital Input Chip Select (Active Low).
14	SCLK	I	Serial Data Clock.
15	SDIO	I/O	Digital Serial Data Input/Output.
7	RESET	I	Digital Input (Active High). Resets internal logic to default states. This pin has an internal 100 k $\Omega$ pull-up resistor, so the default state of the device is reset.
11	XTL0	I	Pin for Connecting an External Crystal (20 MHz to 30 MHz).
12	XTL1	I	Pin for Connecting an External Crystal (20 MHz to 30 MHz).
33	$\overline{\text{OUT1}}$	O	Square Wave Clocking Output 1.
32	$\overline{\text{OUT1}}$	O	Complementary Square Wave Clocking Output 1.
29	$\overline{\text{OUT2}}$	O	Square Wave Clocking Output 2.
28	$\overline{\text{OUT2}}$	O	Complementary Square Wave Clocking Output 2.
17	LF	I/O	Loop Filter Node for the Output PLL. Connect an external 12 nF capacitor (100 nF in 19.44 MHz mode) from this pin to Pin 22 (LDO_VCO).
26	OUTPUT PLL LOCKED	O	Active High Locked Status Indicator for the Output PLL.
25	INPUT PLL LOCKED	O	Active High Locked Status Indicator for the Input PLL.
16	OUTSEL	I	Logic 0 selects LVDS, and Logic 1 selects LVPECL-compatible levels for both OUT1 and OUT2 when the outputs are not under SPI port control. Can be overridden via the programming registers.
8	LDO_IPDIG	P/O	LDO Decoupling Pin. Connect a 0.47 $\mu\text{F}$ decoupling capacitor from this pin to ground.
10	LDO_XTAL	P/O	LDO Decoupling Pin. Connect a 0.47 $\mu\text{F}$ decoupling capacitor from this pin to ground.
22	LDO_VCO	P/O	LDO Decoupling Pin. Connect a 0.47 $\mu\text{F}$ decoupling capacitor from this pin to ground.
24	LDO_1.8	P/O	LDO Decoupling Pin. Connect a 0.47 $\mu\text{F}$ decoupling capacitor from this pin to ground.
35	A0	I	Control Pin. Selects preset values for the REFA dividers.
36	A1	I	Control Pin. Selects preset values for the REFA dividers.
37	A2	I	Control Pin. Selects preset values for the REFA dividers.
38	A3	I	Control Pin. Selects preset values for the REFA dividers.

# AD9551

Pin No.	Mnemonic	Type <sup>1</sup>	Description
39	B0	I	Control Pin. Selects preset values for the REFB dividers.
40	B1	I	Control Pin. Selects preset values for the REFB dividers.
1	B2	I	Control Pin. Selects preset values for the REFB dividers.
2	B3	I	Control Pin. Selects preset values for the REFB dividers.
21	Y0	I	Control Pin. Selects preset values for the output PLL feedback dividers and OUT1 dividers.
20	Y1	I	Control Pin. Selects preset values for the output PLL feedback dividers and OUT1 dividers.
19	Y2	I	Control Pin. Selects preset values for the output PLL feedback dividers and OUT1 dividers.
18	Y3	I	Control Pin. Selects preset values for the output PLL feedback dividers and OUT1 dividers.
EP	Exposed Die Pad		The exposed die pad must be connected to GND.

<sup>1</sup> P = power, I = input, O = output, I/O = input/output, P/O = power/output.

# TYPICAL PERFORMANCE CHARACTERISTICS

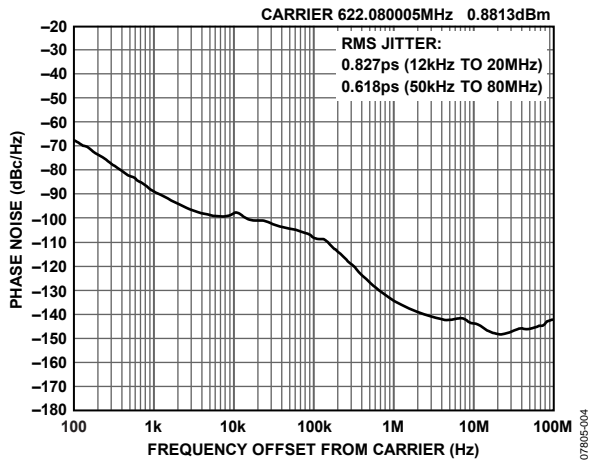

Figure 4. Phase Noise, Fractional-N  
( $f_{IN} = 622.08$  MHz,  $f_{OUT1} = 622.08$  MHz,  $f_{XTAL} = 26$  MHz)

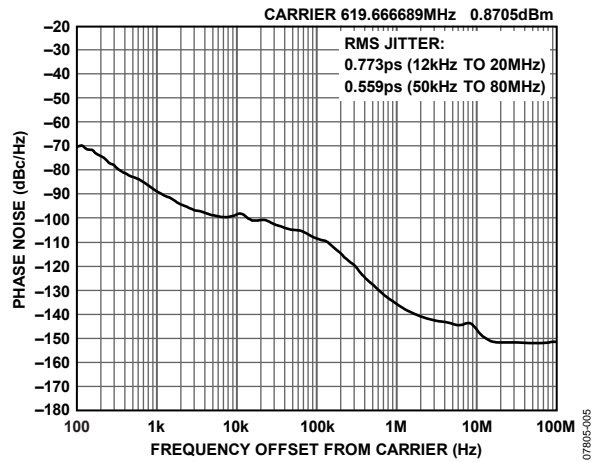

Figure 7. Phase Noise, Integer-N  
( $f_{IN} = 622.08$  MHz,  $f_{OUT1} = 619.67$  MHz,  $f_{XTAL} = 26$  MHz)

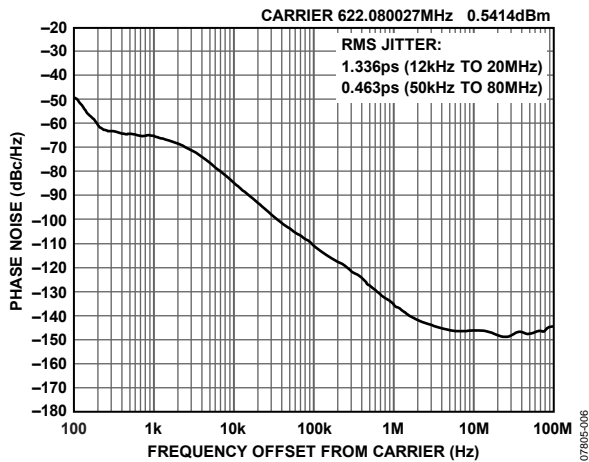

Figure 5. Phase Noise, 19.44 MHz Mode, Fractional-N  
( $f_{IN} = 19.44$  MHz,  $f_{OUT1} = 622.08$  MHz,  $f_{XTAL} = 52$  MHz)

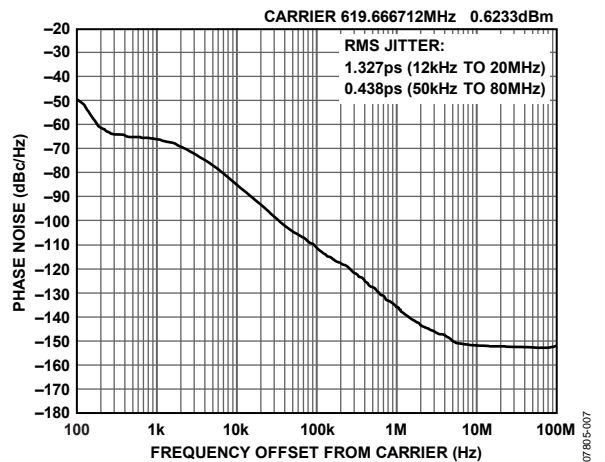

Figure 8. Phase Noise, 19.44 MHz Mode, Integer-N  
( $f_{IN} = 19.44$  MHz,  $f_{OUT1} = 619.67$  MHz,  $f_{XTAL} = 52$  MHz)

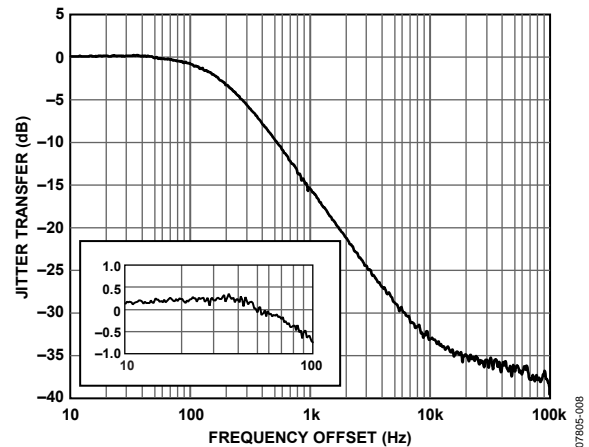

Figure 6. Jitter Transfer (Minimal Peaking)  
(Register 0x33[7] = 0)

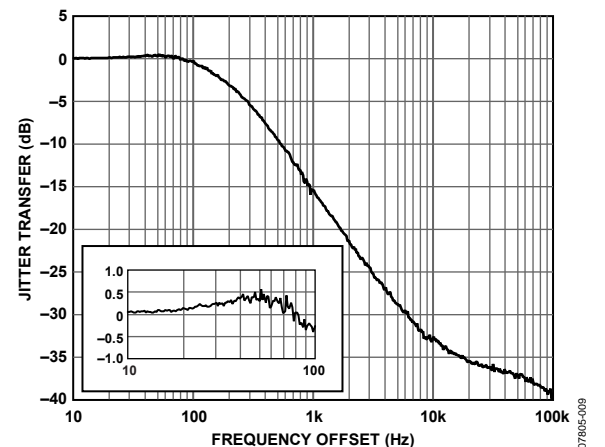

Figure 9. Jitter Transfer (Nominal Peaking)  
(Register 0x33[7] = 1)

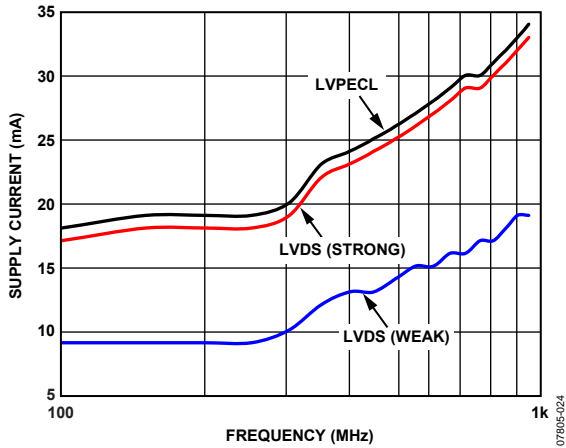

Figure 10. Supply Current vs. Output Frequency—LVPECL and LVDS (10 pF Load)

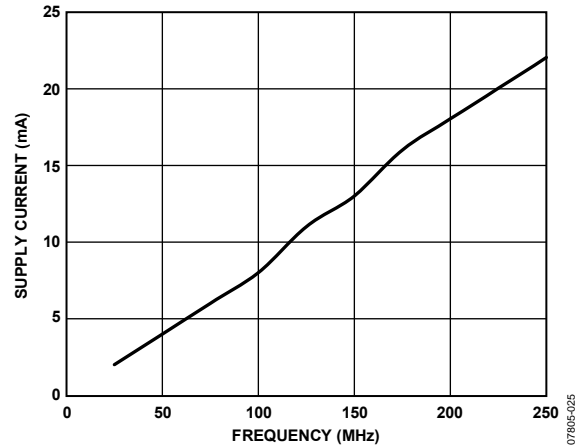

Figure 13. Supply Current vs. Output Frequency—CMOS (10 pF Load)

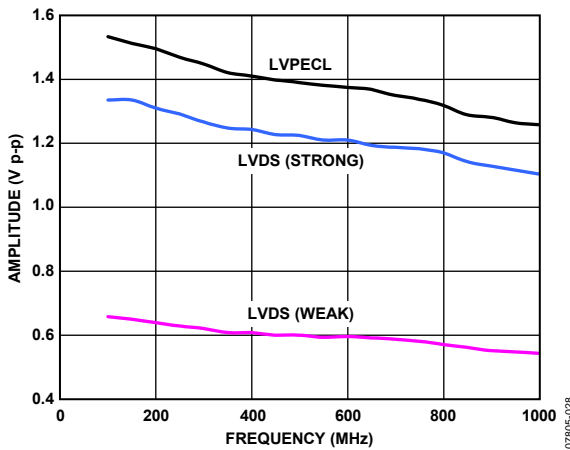

Figure 11. Peak-to-Peak Output Voltage vs. Frequency—LVPECL and LVDS (10 pF Load)

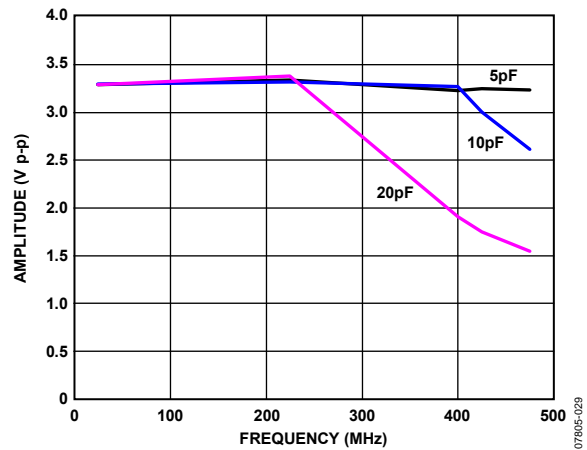

Figure 14. Peak-to-Peak Output Voltage vs. Frequency—CMOS

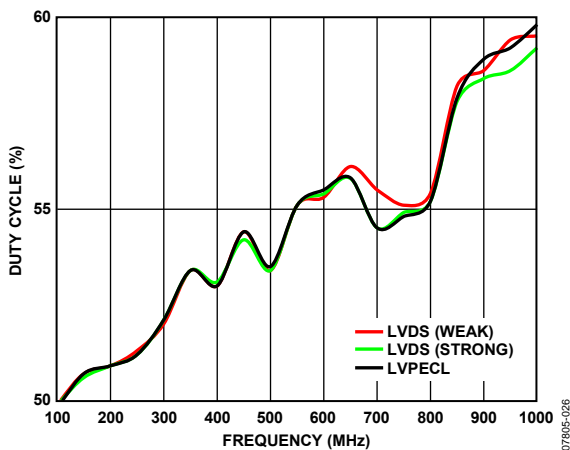

Figure 12. Duty Cycle vs. Output Frequency—LVPECL and LVDS (10 pF Load)

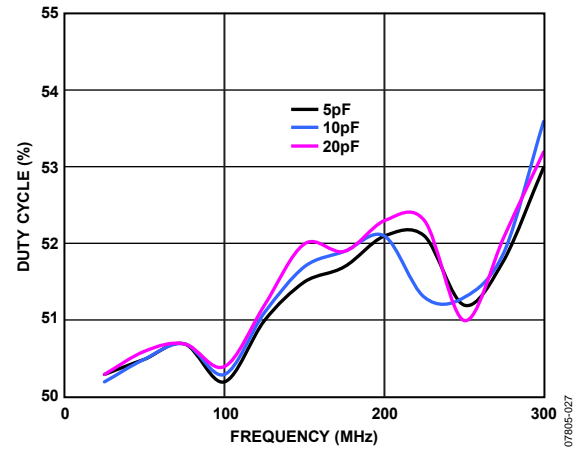

Figure 15. Duty Cycle vs. Output Frequency—CMOS

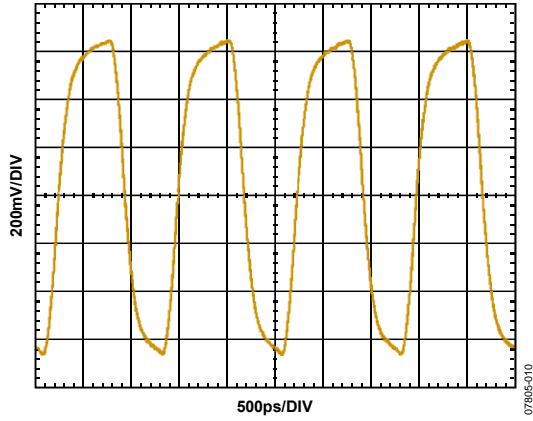

Figure 16. Typical Output Waveform—LVPECL (805 MHz)

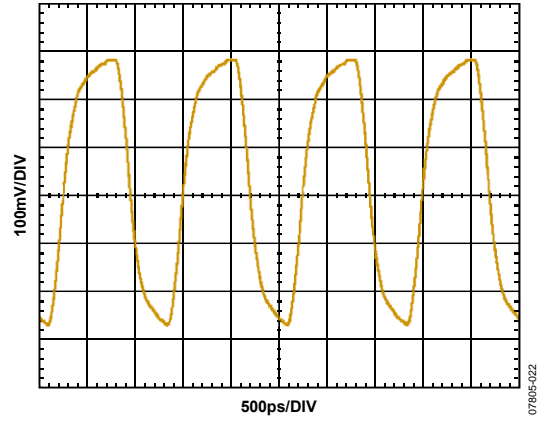

Figure 18. Typical Output Waveform—LVDS (805 MHz, 3.5 mA Drive Current)

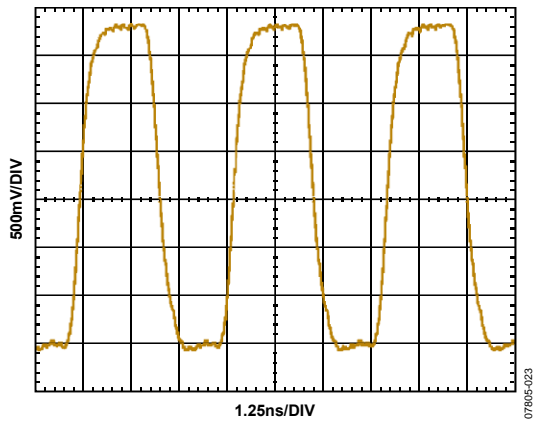

Figure 17. Typical Output Waveform—CMOS (250 MHz, 10 pF Load)

## PRESET FREQUENCY RATIOS

The frequency selection pins (A[3:0], B[3:0], and Y[3:0]) allow the user to hardwire the device for preset input and output divider values based on the pin logic states. The A[3:0] pins control the REFA dividers, the B[3:0] pins control the REFB dividers, and the Y[3:0] pins control the feedback and output dividers. The pins decode ground or open connections as Logic 0 or Logic 1, respectively. To override the preset divider settings, use the serial I/O port to program the desired divider values.

Table 13 lists the input divider values based on the logic state of the frequency selection pins. The table headings are as follows:

- A[3:0], B[3:0]. The logic state of the A[3:0] or B[3:0] pins.
- $N_A$ ,  $N_B$ . The integer part of the REFA input divider ( $N_A$ ) or the REFB input divider ( $N_B$ ).

- $MOD_A$ ,  $MOD_B$ . The modulus of the REFA input divider SDM ( $MOD_A$ ) or the REFB input divider SDM ( $MOD_B$ ).
- $FRAC_A$ ,  $FRAC_B$ . The fractional part of the REFA input divider SDM ( $FRAC_A$ ) or the REFB input divider SDM ( $FRAC_B$ ).
- $f_{REFA}$ ,  $f_{REFB}$ . The frequency of the REFA input ( $f_{REFA}$ ) or the REFB input ( $f_{REFB}$ ).

The divider settings shown in Table 13 cause the frequency at the reference input of the output PLL's PFD ( $f_{IF}$ ) to operate at exactly 26 MHz when using the indicated input reference frequency,  $f_{REFA}$  or  $f_{REFB}$ , assuming the use of a 26 MHz external crystal.

**Table 13. Preset Input Settings**

A[3:0], B[3:0]	$N_A$ , $N_B$	$MOD_A$ , $MOD_B$	$FRAC_A$ , $FRAC_B$	$f_{REFA}$ , $f_{REFB}$ (MHz) <sup>1</sup>
0000	23	130,000	110,800	622.08
0001	24	130,000	-120,000	625
0010	24	154,050	-114,594	$622.08 \left( \frac{239}{237} \right) \approx 627.33$
0011	24	130,000	45,200	$622.08 \left( \frac{66}{64} \right) \approx 641.52$
0100	24	166,400	96,400	$625 \left( \frac{66}{64} \right) \approx 644.53125$
0101	25	104,000	-44,625	$\frac{10518.75}{16} \approx 657.421875$
0110	25	198,016	-42,891	$\frac{10518.75}{16} \left( \frac{239}{238} \right) \approx 660.18$
0111	25	154,700	41,820	$622.08 \left( \frac{255}{238} \right) \approx 666.51$
1000	25	154,050	74,970	$622.08 \left( \frac{255}{237} \right) \approx 669.33$
1001	25	182,000	93,000	$625 \left( \frac{15}{14} \right) \approx 669.64$
1010	25	153,400	108,120	$622.08 \left( \frac{255}{236} \right) \approx 672.16$
1011	26	197,184	67,998	$625 \left( \frac{255}{237} \right) \times \left( \frac{66}{64} \right) \approx 693.48$
1100	26	146,900	83,612	$622.08 \left( \frac{253}{226} \right) \approx 696.40$
1101	27	198,016	-161,755	$\frac{10518.75}{16} \left( \frac{255}{238} \right) \approx 704.38$
1110	27	197,184	-115,995	$\frac{10518.75}{16} \left( \frac{255}{237} \right) \approx 707.35$
1111 <sup>2</sup>	19.44 MHz mode			

<sup>1</sup> Assumes the use of a 26 MHz external crystal.

<sup>2</sup> If all four A[3:0] pins or all four B[3:0] pins are Logic 1, the 19.44 MHz mode is in effect.

The Y[3:0] pins select the divider values for the feedback path of the output PLL, as well as for the OUT1 dividers, P<sub>0</sub> and P<sub>1</sub>. The OUT2 divider, P<sub>2</sub>, defaults to unity unless otherwise programmed using the serial port. Table 14 lists the feedback and output divider values based on the logic state of the Y[3:0] frequency selection pins. The table headings are as follows:

- Y[3:0]. The logic state of the Y[3:0] pins.
- N. The integer part of the feedback divider.
- MOD. The modulus of the feedback SDM.
- FRAC. The fractional part of the feedback SDM.
- P<sub>0</sub>, P<sub>1</sub>. The P<sub>0</sub> and P<sub>1</sub> divider values.
- f<sub>OUT1</sub>. The frequency of the OUT1 output.

The divider settings shown in Table 14 produce the indicated frequency at OUT1 when the frequency at the reference input of the output PLL's PFD (f<sub>IF</sub>) is exactly 26 MHz.

When operating in the 19.44 MHz mode, the N, MOD, and FRAC values may be different from those shown in Table 14, but the f<sub>OUT1</sub> values remain the same. The reason is that the 19.44 MHz mode relies on a crystal with a resonant frequency other than 26 MHz (see the 19.44 MHz Mode section in the Operating Modes portion of the Theory of Operation section).

**Table 14. Preset Output Settings**

Y[3:0]	N	MOD	FRAC	P <sub>0</sub> , P <sub>1</sub>	f <sub>OUT1</sub> (MHz)
0000	143	520,000	289,600	6/1	622.08
0001	144	520,000	120,000	6/1	625
0010	144	308,100	236,736	6/1	$622.08 \left( \frac{239}{237} \right) \approx 627.33$
0011	148	520,000	22,400	6/1	$622.08 \left( \frac{66}{64} \right) \approx 641.52$
0100	148	465,920	343,840	6/1	$625 \left( \frac{66}{64} \right) \approx 644.53125$
0101	151	520,000	370,625	6/1	$\frac{10518.75}{16} \approx 657.421875$
0110	152	465,920	163,160	6/1	$\frac{10518.75}{16} \left( \frac{239}{238} \right) \approx 660.18$
0111	153	465,920	377,856	6/1	$622.08 \left( \frac{255}{238} \right) \approx 666.51$
1000	154	328,640	151,168	6/1	$622.08 \left( \frac{255}{237} \right) \approx 669.33$
1001	154	460,096	245,216	6/1	$625 \left( \frac{15}{14} \right) \approx 669.64$
1010	155	490,880	56,192	6/1	$622.08 \left( \frac{255}{236} \right) \approx 672.16$
1011	133	328,640	119,005	5/1	$625 \left( \frac{255}{237} \right) \left( \frac{66}{64} \right) \approx 693.48$
1100	133	470,080	433,856	5/1	$622.08 \left( \frac{253}{226} \right) \approx 696.40$
1101	135	349,440	159,975	5/1	$\frac{10518.75}{16} \left( \frac{255}{238} \right) \approx 704.38$
1110	136	394,368	11,577	5/1	$\frac{10518.75}{16} \left( \frac{255}{237} \right) \approx 707.35$
1111	149	520,000	280,000	5/1	$622.08 \left( \frac{10}{8} \right) \approx 777.6$

## THEORY OF OPERATION

### OPERATING MODES

The AD9551 provides the following fundamental operating modes:

- Normal mode
- 19.44 MHz mode

Mode selection depends on the state of the frequency selection pins (A[3:0] and B[3:0]). If all four of the A[3:0] pins or all four of the B[3:0] pins are Logic 1s, the 19.44 MHz mode is in effect.

Otherwise, normal mode is in effect.

#### Normal Mode

Normal mode offers two methods of operation. The first method relies on the frequency selection pins to configure the device. The second method involves the use of the serial port for device configuration.

The first method is for applications that use one of the input/output frequency sets defined in Table 13 and Table 14 (excluding the 19.44 MHz mode selection). The advantage of this method is that the serial port is not required. Connect the pins to the appropriate logic levels, and the device operates with the defined input and output frequencies. The pin settings establish all the necessary internal divider values. Note, however, that this method requires an external crystal with a resonant frequency of 26 MHz.

The second method, which relies on the serial port, enables the user to program custom divider settings to achieve input/output frequency ratios not available via the frequency selection pins. Furthermore, the 26 MHz constraint on the external crystal no longer applies. Note, however, that the external pin settings still establish the default values of the dividers. The serial port simply enables the user to override the default settings.

#### 19.44 MHz Mode

This special operating mode allows for input references that operate specifically at 19.44 MHz, 38.88 MHz, or 77.76 MHz. The 19.44 MHz mode is invoked by the frequency selection pins and occurs when either A[3:0] = 1111b or B[3:0] = 1111b. Furthermore, this mode requires an external crystal with one of the following four possible resonant frequencies, based on the contents of Register 0x33[5:4].

- 49.152 MHz
- 49.860 MHz
- 50.000 MHz
- 52.000 MHz

In the 19.44 MHz mode, the reference input dividers allow for integer divide ratios of 1, 2, or 4 only, set via Register 0x1E[1:0]. Therefore, if  $f_{IN} = 19.44$  MHz, the divide ratio must be set to 1; if  $f_{IN} = 38.88$  MHz, the divide ratio must be set to 2; and if  $f_{IN} = 77.76$  MHz, the divide ratio must be set to 4.

Note that for applications using both REFA and REFB in the 19.44 MHz mode, the input frequencies must match.

Although the 19.44 MHz mode limits the input divide ratio to 1, 2, or 4, the user has full control of the dividers in the output section. This includes the integer and fractional components of the output PLL feedback divider and the final output dividers ( $P_0$ ,  $P_1$ , and  $P_2$ ), enabling the synthesis of a wide range of output frequencies.

Note that the 19.44 MHz mode alters the configuration of the input PLL (see the Input PLL section).

When using the 19.44 MHz mode, the loop filter in the output PLL requires a 100 nF capacitor. Furthermore, the user must program the output PLL charge pump current to 25  $\mu$ A (via Register 0x0A). Note that SPI port programming capability is necessary when using 19.44 MHz mode because it requires a charge pump current that is different from the default value.

### COMPONENT BLOCKS

#### Input Dividers

Each reference input feeds a dedicated reference divider block. The input dividers provide division of the reference frequency in integer steps from 1 to 63. They provide the bulk of the frequency prescaling necessary to reduce the reference frequency to accommodate the bandwidth limitations of both the input and output PLLs.

#### Input Sigma-Delta Modulators (SDM)

Each of the two input dividers is coupled with an optional, second-order SDM, enabling fractional division of the input reference frequency. With both integer and fractional divide capability, the AD9551 can accept two different reference frequencies that span a wide range of possible input frequency ratios.

A typical SDM offers fractional division in the form  $N + F/M$ , where  $N$  is the integer part,  $M$  is the modulus, and  $F$  is the fractional part ( $F < M$ ). All three parameters are positive integers. The input SDMs of the AD9551 are atypical in that they implement fractional division in the form,  $N + 1/2 + F/(2M)$ , with  $F$  being a signed integer, and  $|F| < M$ . Note that when the SDM is in use, the minimum integer divide value is 4.

Both SDMs have an integrated pseudorandom binary sequence (PRBS) generator. The PRBS generator serves to suppress spurious artifacts by adding a random component to the SDM output. By default, the PRBS generator is active in both input SDMs, but the user can disable the PRBS using Register 0x1E[2].

Note that in 19.44 MHz mode, the input SDMs are inactive and unavailable.

#### Reference Monitor

The reference monitor verifies the presence or absence of the prescaled REFA and REFB signals (that is, after division by the input dividers). The status of the reference monitor guides the activity of the synchronization and switchover control logic.

Note that the DCXO must be operational for the reference monitor to function.

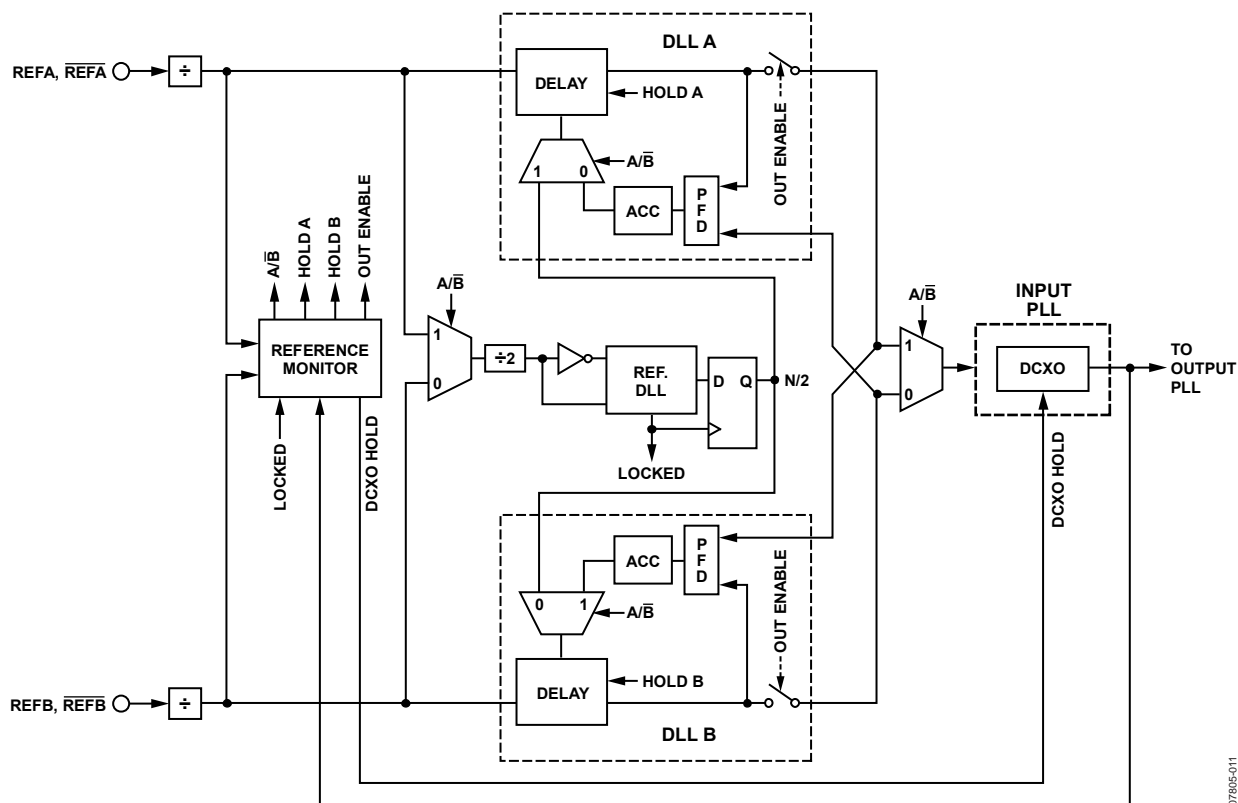

Figure 19. Synchronization Block Diagram

### Synchronization/Switchover Control

Figure 19, which is a block diagram of the hitless reference switchover circuit, shows that reference synchronization occurs after the input reference dividers. The synchronization and switchover functionality relies on the reference monitor logic to control the operation of the three delay-locked loops (DLLs). The delay blocks of the three DLLs are identical, so that they exhibit the same time delay for a given delay value setting.

Note that the DCXO must be operational for the synchronization and switchover control to operate.

Both the REFA and REFB paths have a dedicated DLL (DLL A and DLL B, respectively). DLL A and DLL B are each capable of operating in either an open-loop or closed-loop mode under the direction of the reference monitor status signals. When the reference monitor selects one of the references as the active reference, the DLL associated with the active reference operates in open-loop mode. While in open-loop mode, the DLL delays the active reference by a constant time interval based on a fixed delay value. As long as one of the references is the active reference, the other reference is, by default, the alternate reference. The DLL associated with the alternate reference operates in closed-loop mode. While in closed-loop mode, the DLL automatically adjusts its delay so that the rising edge of the delayed alternate reference is edge-aligned with the rising edge of the delayed active reference.

When the reference monitor selects one of the references as the active reference, it switches the output mux to select the output of the DLL associated with the active reference and, simultaneously, routes the active reference to the reference DLL. The reference DLL automatically measures the period of the active reference (with approximately 250 ps accuracy). When the reference DLL locks, the value of its delay setting (N) represents one period of the active reference. Upon acquiring lock, the reference DLL captures N and divides it by two (N/2 corresponds to a delay value that represents a half-cycle of the active reference). Both DLL A and DLL B have access to the N/2 value generated by the reference DLL.

The following paragraphs describe the typical sequence of events resulting from a device reset, power-up, or return from hold-over mode.

### Active Reference and Alternate Reference

The reference monitor continuously checks for the presence of the divided REFA and/or REFB signals. If both signals are available, the device arbitrarily selects one of them as the active reference, making the other the alternate reference. If only one of the references is available, it becomes the active reference, making the other the alternate reference (if it ever becomes available). In either case, the following two events occur:

- The output mux selects the output of the active DLL as the source to the input PLL.
- The input mux selects the active reference as the source to the reference DLL.

The reference DLL measures the period of the active reference and produces the required  $N/2$  delay value. When the reference DLL locks, the following three events occur:

- Both DLL A and DLL B are enabled.
- The DLL associated with the active reference enters open-loop mode.
- The DLL associated with the alternate reference enters closed-loop mode.

This implies that the signal driving the input PLL is the active reference (after division by its input divider) with a half-cycle delay.

Because the alternate DLL is in closed-loop mode, and assuming that the alternate reference is available, the output of the alternate DLL is edge-aligned with the delayed output of the active DLL. Furthermore, the closed-loop operation of the alternate DLL causes its delay value to be adjusted dynamically so that it maintains nominal edge alignment with the output of the active DLL. Edge alignment of the active and alternate references is the key to the hitless switchover capability of the AD9551.

### Reference Switchover and Holdover Mode

If the reference monitor detects the loss of the active reference, it initiates the following three simultaneous operations:

- The output mux selects the output of the alternate DLL.
- The alternate DLL holds its most recent delay setting (that is, the delay setting that edge-aligned the output of the alternate DLL with the output of the active DLL). Note that this operation ensures hitless switching between references.
- The new active reference is connected to the reference DLL to measure its period (that is, a new  $N/2$  value).

Because the failed alternate reference is assigned to the alternate DLL, upon its return the alternate DLL (which is in closed-loop mode) automatically edge-aligns the delayed alternate reference with the delayed active reference. Thus, if the new active reference fails, switchover to the alternate reference occurs in a hitless manner. This method of swapping the functionality of DLL A and DLL B as either active (open-loop) or alternate (closed-loop) allows for continuous hitless switching from one reference to the other, as needed (assuming the availability of an alternate reference upon failure of the active reference).

Note that if both references fail, the device enters holdover mode. In this case, the reference monitor holds the DCXO at its last setting prior to the holdover condition, and the DCXO free runs at this setting until the holdover condition expires.

### Forcing Selection of the Active Reference

Because the synchronization mechanism autonomously switches between references, the user has no way of knowing which reference is currently the active reference. However, the device can be forced to select a specific input reference as the active reference. For example, to force REFA to be the active reference, power down the REFB input receiver by programming the appropriate registers (or disconnect the REFB signal source).

The absence of a REFB signal causes the device to perform a hitless switchover to REFA. If REFA is already the active reference, the absence of REFB results in no action, and REFA remains the active reference. In this way, the user can ensure that REFA is the active reference. Likewise, by using the same procedure but reversing the roles of the two references, the user can force the device to select REFB as the active reference.

### Digitally Controlled Crystal Oscillator (DCXO)

The DCXO is the fundamental building block of the input PLL (see the Input PLL section). The DCXO relies on an external crystal (19.44 MHz to 52 MHz) as its frequency source. The resonant frequency of the external crystal varies as a function of the applied load capacitance. The AD9551 has two internal capacitor banks (static and dynamic) that provide the required load capacitance. In operation, the control loop of the input PLL automatically adjusts the value of the capacitive load to push or pull the crystal resonant frequency over a small range of approximately  $\pm 50$  ppm.

The tuning capacitor bank sets the static load capacitance, which defaults to  $\sim 2$  pF. The varactor bank is a dynamic capacitance controlled by the DCXO to push or pull the crystal resonant frequency. The nominal varactor capacitance is  $\sim 6$  pF, and when combined with the 2 pF static capacitance and 2 pF of typical parasitic capacitance, the total crystal load capacitance is  $\sim 10$  pF (default).

The user can alter the default load capacitance by changing the static load capacitance of the tuning capacitor bank via Register 0x1B[5:0]. These six bits set the static load capacitance in 0.25 pF increments up to a maximum of  $\sim 16$  pF.

The control loop of the input PLL locks the DCXO to the active reference signal by dynamically controlling the varactor capacitance. Note that the narrow frequency control range ( $\pm 50$  ppm) of the varactor bank, combined with the default operating parameters of the AD9551, dictate the use of a crystal with specified load capacitance of 10 pF and a frequency tolerance of 20 ppm (see the NDK NX3225SA, for example).

The narrow tuning range of the DCXO has two implications. First, the user must properly choose the divide ratio of the input reference divider to establish a frequency that is within the DCXO tuning range. Second, the user must ensure that the jitter/wander of the input reference is low enough to ensure the stability of the input PLL control loop for applications where the DCXO is the reference source for the output PLL (the default configuration). Normally, the input SDMs help to mitigate the input jitter because of the way they interact with the behavior of the input PLL. Input jitter becomes an issue, however, when the input dividers operate in integer-only mode or the input PLL is bypassed.

## Input PLL

The input PLL consists of a phase/frequency detector (PFD), a digital loop filter, and a digitally controlled crystal oscillator (DCXO) that operates in a closed loop. The loop contains a  $2\times$  frequency multiplier, a  $2\times$  frequency divider, a  $5\times$  divider that has a dedicated SDM, and switching logic, as shown in Figure 20.

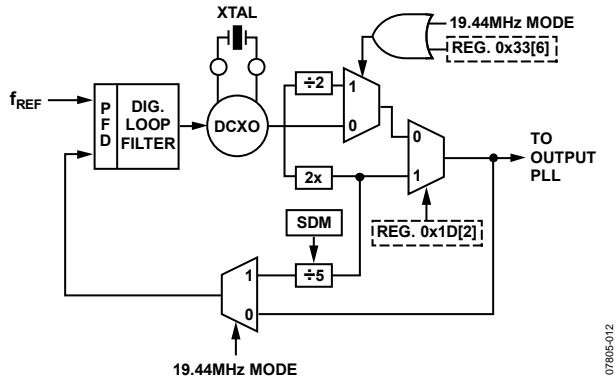

Figure 20. Input PLL

The input PLL has a digital loop filter with a loop bandwidth of approximately 180 Hz. This relatively narrow loop bandwidth gives the AD9551 the ability to suppress jitter appearing on the input references (REFA and REFB). By default, the sample rate of the digital loop filter is  $f_{REF}/8$  ( $f_{REF}$  is the frequency of the active input reference after it is scaled down by the input divider). This yields a loop response with peaking of typically  $<0.2$  dB. For applications that can benefit from a reduced acquisition time but can tolerate more peaking ( $\sim 0.5$  dB), the user can increase the sample rate of the loop filter to  $f_{REF}$  via Register 0x33[7].

The configuration of the input PLL depends on the state of the frequency selection pins, which establishes whether the device operates in the normal mode or the 19.44 MHz mode. The configuration of the input PLL also depends on the state of the  $2\times$  frequency multiplier bit (Register 0x1D[2]) and the state of the  $2\times$  frequency divider bit (Register 0x33[6]).

With the device in normal mode, the input PLL feedback signal and the signal delivered to the output PLL are the same. In this mode, the user has three options to scale the frequency at the output of the DCXO.

- Unity (default). The crystal frequency is the same as  $f_{REF}$ .
- Frequency upconversion using the  $2\times$  multiplier:  $f_{REF}$  is twice the crystal frequency
- Frequency downconversion using the  $2\times$  divider:  $f_{REF}$  is half the crystal frequency.

To select the upconversion option, set Register 0x1D[2] to 1. To select the downconversion option, set Register 0x33[6] to 1.

Note that setting Register 0x1D[2] to 1 renders Register 0x33[6] ineffective (see Figure 20).

In all cases mentioned previously, the user must ensure that  $f_{REF}$  meets the required relationship relative to the crystal resonant frequency. This is important because the narrow control range of the DCXO requires close adherence to the required frequency ratio (1/2, 1, or 2, depending on the selected option). Note, also, that the frequency delivered to the output PLL is always the same as  $f_{REF}$  in normal mode.

When the device is in 19.44 MHz mode, the user must ensure that  $f_{REF} = 19.44$  MHz. In 19.44 MHz mode, the configuration of the input PLL is different from that of normal mode. Specifically, the feed-back signal and the signal delivered to the output PLL are no longer the same. Instead, the device automatically configures the feedback path to include the  $2\times$  frequency multiplier along with a  $5\times$  divider coupled to a dedicated third-order SDM. The device automatically sets the modulus of this SDM based on the crystal frequency configured by Register 0x33[5:4]. This SDM also has a built-in PRBS generator to randomize its output sequence.

Even though the device automatically configures the feedback path in 19.44 MHz mode, the user can select the  $2\times$  multiplied or  $2\times$  divided output of the DCXO as the signal to the output PLL. The  $2\times$  divider is in effect when Register 0x1D[2] = 0 (default). The  $2\times$  multiplier is in effect when Register 0x1D[2] = 1. Note that, unlike normal mode, the 19.44 MHz mode does not have a unity option.

Using Register 0x1D[1] allows the user to bypass the entire input PLL section. With the input PLL bypassed, the prescaled active input reference signal (after synchronization) routes directly to the PFD of the output PLL. However, even when the input PLL is bypassed, the user must provide an external crystal so that the DCXO is functional because the reference monitor and reference synchronization blocks use the DCXO output as a clock source.

## Output PLL

The output PLL consists of a phase-frequency detector (PFD), a partially integrated analog loop filter (Figure 21), an integrated voltage-controlled oscillator (VCO), and a feedback divider with an optional third-order SDM that allows for fractional divide ratios. The output PLL produces a nominal 3.7 GHz signal that is phase-locked to the prescaled active input reference signal.

The PFD of the output PLL drives a charge pump that increases, decreases, or holds constant the charge stored on the loop filter capacitors (both internal and external). The stored charge results in a voltage that sets the output frequency of the VCO. The feedback loop of the PLL causes the VCO control voltage to vary in such a way as to phase lock the PFD input signals.

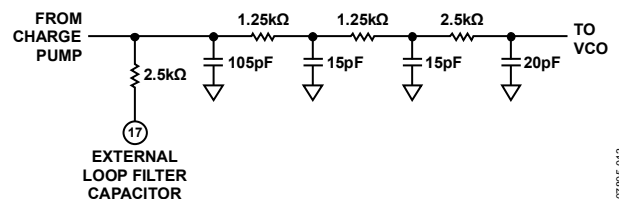

Figure 21. Internal Loop Filter

The gain of the output PLL is proportional to the current delivered by the charge pump. The user can override the default charge pump current setting, and, thereby, the PLL gain, by using Register 0x0A[7:0].

The output PLL has a VCO with 128 frequency bands spanning a range of 3350 MHz to 4050 MHz (3700 MHz nominal). However, the actual operating frequency within a particular band depends on the control voltage that appears on the loop filter capacitor. The control voltage causes the VCO output frequency to vary linearly within the selected band. This frequency variability allows the control loop of the output PLL to synchronize the VCO output signal with the reference signal applied to the PFD. Typically, the device selects the appropriate band and adjusts the signal level as part of its calibration process. However, the user can force calibration by first enabling SPI control of VCO calibration (Register 0x0E[2] = 1) and then writing a 1 to the calibrate VCO bit (Register 0x0E[7]). To facilitate system debugging, the user can override the VCO band setting by first enabling SPI control of the VCO band (Register 0x0E[0] = 1) and then writing the desired value to Register 0x10[7:1].

The output PLL has a feedback divider coupled with a third-order SDM (similar to the REFA and REFB input dividers) that enables the output PLL to provide integer-plus-fractional frequency up-conversion. The integer factor, N, is variable from 0 to 255 via an 8-bit programming register. However, the minimum practical value of N is 64 because this sufficiently reduces the VCO frequency in the PLL feedback path to an acceptable range. The SDM in the feedback path allows for a fractional divide value that takes the form of  $N + F/M$ , where N is the integer part (eight bits), M is the modulus (20 bits), and F is the fractional part (20 bits), with all three parameters being positive integers. The feedback SDM gives the AD9551 the ability to support a wide range of output frequencies with exact frequency ratios relative to the input reference.

### PLL Locked Indicators

Both the input and output PLLs provide a status indicator that appears at an external pin. The indicator shows when the PLL has acquired a locked condition. The input PLL provides the INPUT PLL LOCKED signal, and the output PLL provides the OUTPUT PLL LOCKED signal.

### Output Drivers

Three integer dividers exist in the output chain. The first divider ( $P_0$ ) yields an integer submultiple of the VCO frequency. The second divider ( $P_1$ ) establishes the frequency at OUT1 as an integer submultiple of the output frequency of the  $P_0$  divider. The third divider ( $P_2$ ) establishes the output frequency at OUT2 as an integer submultiple of the OUT1 frequency.

### Output Drivers

The user has control over the following output driver parameters via the programming registers:

- Logic family and pin functionality
- Polarity (for CMOS family only)
- Drive current
- Power-down

The logic families are LVDS, LVPECL, and CMOS. Selection of the logic family is via the mode control bits in the OUT1 driver control register (Register 0x32[5:3]) and the OUT2 driver control register (Register 0x34[5:3]), as detailed in Table 15. Regardless of the selected logic family, each output driver uses two pins: OUT1 and  $\overline{\text{OUT1}}$  are used by one driver, and OUT2 and  $\overline{\text{OUT2}}$  are used by the other. This enables support of the differential signals associated with the LVDS and LVPECL logic families. CMOS, on the other hand, is a single-ended signal requiring only one output pin, but both output pins are available for optional provision of a dual, single-ended CMOS output clock. Refer to the first entry (CMOS (both pins)) in Table 15.

**Table 15. Output Channel Logic Family and Pin Functionality**

Mode Control Bits[2:0]	Logic Family and Pin Functionality
000	CMOS (both pins)
001	CMOS (positive pin), tristate (negative pin)
010	Tristate (positive pin), CMOS (negative pin)
011	Tristate (both pins)
100	LVDS
101	LVPECL
110	Undefined
111	Undefined

If the mode bits indicate the CMOS logic family, the user has control of the logic polarity associated with each CMOS output pin via the OUT1 and OUT2 driver control registers.

If the mode bits indicate the CMOS or LVDS logic family, the user can select whether the output driver uses weak or strong drive capability via the OUT1 and OUT2 driver control registers. In the case of the CMOS family, the strong setting allows for driving increased capacitive loads. In the case of the LVDS family, the nominal weak and strong drive currents are 3.5 mA and 7 mA, respectively.

The OUT1 and OUT2 driver control registers also have a power-down bit to enable/disable the output drivers. The power-down function is independent of the logic family selection.

Note that, unless the user programs the device to allow SPI port control of the output drivers, the drivers default to LVPECL or LVDS, depending on the logic level on the OUTSEL pin (Pin 16). For OUTSEL = 0, both outputs are LVDS. For OUTSEL = 1, both outputs are LVPECL. In the pin-selected LVDS mode, the user can still control the drive strength, using the SPI port.

## HOLDOVER MODE

In the absence of both input references, the device enters holdover mode. Holdover is a secondary function that is provided by the input PLL. Because the DCXO has an external crystal as its frequency source, it continues to operate in the absence of the input reference signals. When the device switches to holdover, the DCXO is held at the frequency at which it was operating just prior to switchover. The device continues operating in this mode until a reference signal becomes available; the device then exits holdover mode, and the input PLL resynchronizes with the active reference.

## JITTER TOLERANCE

Jitter tolerance is the ability of the AD9551 to maintain lock in the presence of sinusoidal jitter. The AD9551 meets the DS1 reference input jitter tolerance mask per Telcordia GR-1244-CORE (see Figure 22). The acceptable jitter tolerance is the region above the mask.

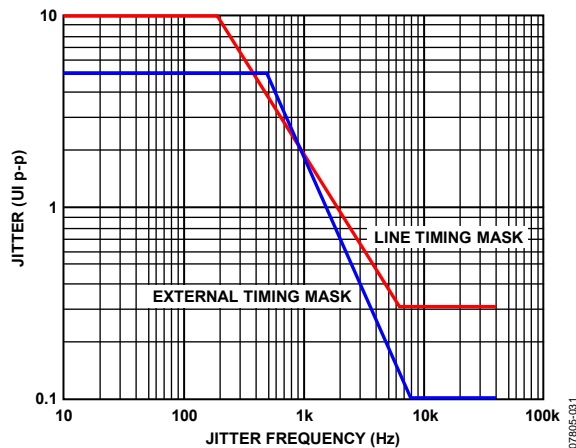

Figure 22. Jitter Tolerance

## EXTERNAL LOOP FILTER CAPACITOR

The output PLL loop filter requires the connection of an external capacitor from LF (Pin 17) to LDO\_VCO (Pin 22). The value of the external capacitor depends on the operating mode (normal or 19.44 MHz). Normal mode requires a 12 nF capacitor that sets the loop bandwidth at approximately 70 kHz and ensures loop stability over the intended operating parameters of the device. The 19.44 MHz mode requires a 100 nF capacitor, along with a change in the output PLL charge pump current to 25  $\mu$ A, via Register 0x0A. This establishes similar loop bandwidth and stability criteria as found in normal mode.

Note that the 19.44 MHz mode does not function properly unless the user changes the output PLL charge pump current from its default setting to 25  $\mu$ A.

## OUTPUT/INPUT FREQUENCY RELATIONSHIP

Following are the three equations that define the frequency at OUT1 and OUT2 ( $f_{OUT1}$  and  $f_{OUT2}$ , respectively). Note that in the equations throughout this datasheet, the subscripted x indicates A or B.

$$f_{IF} = f_{REF_x} \left( \frac{K}{N_x + \left( \frac{1}{2} + \frac{FRAC_x}{2(MOD_x)} \right)} \right) \quad 1)$$

$$f_{OUT1} = f_{IF} \left( \frac{N + \frac{FRAC}{MOD}}{P_0 P_1} \right) \quad 2)$$

$$f_{OUT2} = \frac{f_{OUT1}}{P_2} \quad 3)$$

where:

$f_{REFA}$  and  $f_{REFB}$  are the input reference frequency, with the subscripted A or B indicating REFA or REFB, respectively.

$f_{IF}$  is the frequency at the input of the output PLL's PDF.

$P_0$  and  $P_1$  are OUT1 divider values.

$P_2$  is the OUT2 divider value.

$K$  is the input mode scale factor.

$N_A$ ,  $N_B$ ,  $FRAC_A$ ,  $FRAC_B$ ,  $MOD_A$ , and  $MOD_B$  are the input reference divider values, with the A or B subscript indicating REFA or REFB, respectively.

$N$ ,  $FRAC$ , and  $MOD$  are the feedback divider values for the output PLL.

The various dividers have the following constraints:

$$N_x \in \{1, 2, \dots, 63\} \text{ with SDM disabled}$$

$$N_x \in \{3, 4, \dots, 63\} \text{ with SDM active}$$

$$FRAC_x \in \{-524,288, -524,287, \dots, 524,287\}$$

$$MOD_x \in \{1, 2, \dots, 524,287\}$$

$$N \in \{64, 65, \dots, 255\}$$

$$FRAC \in \{0, 1, \dots, 1,048,575\}$$

$$MOD \in \{1, 2, \dots, 1,048,575\}$$

$$P_0 \in \{4, 5, \dots, 11\}$$

$$P_1 \in \{1, 2, \dots, 63\}$$

$$P_2 \in \{1, 2, \dots, 63\}$$

The VCO imposes the following constraint on  $f_{IF}$ :

$$\left( \frac{3350}{N + \frac{FRAC}{MOD}} \right) \text{MHz} \leq f_{IF} \leq \left( \frac{4050}{N + \frac{FRAC}{MOD}} \right) \text{MHz}$$

The input frequencies ( $f_{REFA}$  and  $f_{REFB}$ ) must satisfy the following relationship:

$$\frac{f_{REFA}}{N_A + \left( \frac{1}{2} + \frac{FRAC_A}{2(MOD_A)} \right)} = \frac{f_{REFB}}{N_B + \left( \frac{1}{2} + \frac{FRAC_B}{2(MOD_B)} \right)}$$

# AD9551

The value of K depends on the device configuration, as shown in Table 16.

**Table 16. Configuring the Value of K**

Mode	f <sub>CRYSTAL</sub>	K	Description
19.44 MHz	52 MHz	1300/243	Using 2× multiplier
		325/243	Using 2× divider
	50 MHz	1250/243	Using 2× multiplier
		625/486	Using 2× divider
49.86 MHz	277/54	Using 2× multiplier	
	277/216	Using 2× divider	
49.152 MHz	2048/405	512/405	Using 2× multiplier
			Using 2× divider
Normal		1	Crystal independent

The user must carefully consider the operating frequency of the externally connected crystal resonator (assuming that the input PLL is not bypassed). Because the DCXO is capable of pulling the crystal over a 50 ppm range only, the output frequency of the DCXO is essentially identical to the crystal frequency.

The denominator of Equation 1 is the input division factor, which has an integer part (N<sub>x</sub>) due to an integer divider, as well as an optional fractional part that is associated with the input SDM.

$$1/2 + \text{FRAC}_x / (2 \times \text{MOD}_x)$$

Note that when bypassing the SDM, the device forces the fractional part to 0 (equivalent to  $\text{FRAC}_x = -\text{MOD}_x$ ).

The numerator of Equation 2 contains the feedback division factor, which has an integer part (N) due to an integer divider, as well as an optional fractional part (FRAC/MOD) that is associated with the feedback SDM.

Equation 1 and Equation 2, along with the constraints placed on their variables, imply a rational relationship between f<sub>REF</sub> and f<sub>OUT1</sub>. That is, the ratio f<sub>OUT1</sub>/f<sub>REF</sub> must be expressible as a ratio of two integers. For example, it is not possible to configure the device to satisfy a frequency ratio having a value of -2 because it is irrational (that is, not expressible as a ratio of two integers).

## CALCULATING DIVIDER VALUES

This section provides a 5-step procedure for calculating the divider values when given a specific f<sub>OUT1</sub>/f<sub>REF</sub> ratio. The methodology is described in general terms, but a specific example is provided for clarity. The example assumes the use of the frequency control pins with A[3:0] = 0010 and Y[3:0] = 0100 (see Table 13 and Table 14). The example parameters are as follows:

$$f_{REF} = 622.08 \left( \frac{239}{237} \right) \text{ MHz}$$

$$f_{OUT1} = 625 \left( \frac{66}{64} \right) \text{ MHz}$$

$$f_{IF} = 26 \text{ MHz}$$

## Calculation Steps

1. Ensure that f<sub>OUT1</sub> and f<sub>REF</sub> are rationally related.

As shown in the following equation, f<sub>OUT1</sub>/f<sub>REF</sub> is expressible as a ratio of two integers, so f<sub>OUT1</sub> and f<sub>REF</sub> are rationally related.

$$\frac{f_{OUT1}}{f_{REF}} = \frac{625 \left( \frac{66}{64} \right)}{622.08 \left( \frac{239}{237} \right)} = \frac{625(66)(237)(100)}{62208(239)(64)} = \frac{977,625,000}{951,553,568}$$

2. Determine the output divide factor (ODF).

Note that the VCO frequency (f<sub>VCO</sub>) spans 3350 MHz to 4050 MHz. The ratio, f<sub>VCO</sub>/f<sub>OUT1</sub>, indicates the required ODF. Given the specified value of f<sub>OUT1</sub> (~644.53 MHz) and the range of f<sub>VCO</sub>, the ODF spans a range of 5.2 to 6.3. The ODF must be an integer, which means that ODF = 6 (because 6 is the only integer between 5.2 and 6.3).

3. Determine suitable values for P<sub>0</sub> and P<sub>1</sub>.

The ODF is the product of the two output dividers; that is, ODF = P<sub>0</sub> × P<sub>1</sub>. It has already been determined that ODF = 6 for the given example. Therefore, we have P<sub>0</sub> × P<sub>1</sub> = 6, with the constraints that P<sub>0</sub> and P<sub>1</sub> are both integers and that 4 ≤ P<sub>0</sub> ≤ 11 (see the Output/Input Frequency Relationship section). These constraints lead to the singular solution of P<sub>0</sub> = 6, and P<sub>1</sub> = 1.

Although this particular example yields a singular solution for the output divider values with f<sub>OUT1</sub> ≈ 644.53 MHz, some f<sub>OUT1</sub> frequencies result in multiple ODFs rather than just one. For example, if f<sub>OUT1</sub> = 100 MHz, the ODF ranges from 34 to 40. This leads to an assortment of possible values for P<sub>0</sub> and P<sub>1</sub>, as shown in Table 17.

The P<sub>0</sub> and P<sub>1</sub> combinations listed in Table 17 are all equally valid. However, note that they yield only three valid ODF values (35, 36, and 40) from the original range of 34 to 40.

**Table 17. Combinations of P<sub>0</sub> and P<sub>1</sub>**

P <sub>0</sub>	P <sub>1</sub>	ODF
4	9	36
4	10	40
5	7	35
5	8	40
6	6	36
7	5	35
8	5	40
9	4	36
10	4	40



As in Step 4, use long division to convert the fraction, X/Y, to an integer, N, and a proper fraction, R/Y (R and Y are integers). The same caution given in Step 4 applies here, regarding the need to use long division rather than a calculator or a math program.

Given the example of X = 14,867,712 and Y = 616,200, long division yields the following: N = 24 and R/Y = 78,912/616,200, which reduces to R/Y = 3,288/25,675. The only caveats are that N must meet the constraints for N<sub>A</sub> and N<sub>B</sub> given in the Output/Input Frequency Relationship section and that Y < 2<sup>19</sup> (524,288).

Next, use R and Y to compute the following:

$$Q = 2R - Y$$

Using R = 3288 and Y = 25,675 from the previous example yields

$$Q = 2 \times 3288 - 25,675 = -19,099$$

These values of N, Q, and Y constitute the respective input divider values: N<sub>x</sub> = 24, FRAC<sub>x</sub> = -19,099, and MOD<sub>x</sub> = 25,675.

In the example, FRAC<sub>x</sub> is nonzero, so the division value is an integer plus the fractional component, FRAC<sub>x</sub>/MOD<sub>x</sub>. This implies that the input SDM is necessary as part of the input divider. If FRAC<sub>x</sub> = 0, then the input division factor is an integer and the SDM is not required (it can be bypassed).

The choice of MOD<sub>x</sub> affects the jitter performance of the input section in a manner similar to the feedback dividers. However, the spectral spacing of the spurs for the input SDMs is as follows:

$$\Delta f_x = \frac{f_{REF_x}}{(MOD_x) \times (2N_x + 1) + FRAC_x}$$

The input SDMs are similar to the feedback SDM in that it is desirable to scale MOD<sub>x</sub> and FRAC<sub>x</sub> by the integer part of 2<sup>19</sup>, divided by the value of MOD<sub>x</sub> that was calculated previously in Step 5. In the example calculation, the value of MOD<sub>x</sub> is 25,675, which leads to a scale factor of 20 (the integer part of 2<sup>19</sup>/25,675). A scale factor of 20 yields the following results: FRAC<sub>x</sub> = -19,099 × 20 = -381,980 and MOD<sub>x</sub> = 25,675 × 20 = 513,500.

However, these FRAC<sub>x</sub> and MOD<sub>x</sub> values are different from those that appear in Table 13 (A[3:0] = 0010). The reason is that a scale factor of 6 (instead of 20) was found to yield the most acceptable overall performance. A scale factor of 6 results in the following Table 13 values: FRAC<sub>x</sub> = -19,099 × 6 = -114,594, and MOD<sub>x</sub> = 25,675 × 6 = 154,050.

## LOW DROPOUT (LDO) REGULATORS

The AD9551 is powered from a single 3.3 V supply and contains on-chip LDO regulators for each function to eliminate the need for external LDOs. To ensure optimal performance, each LDO output should have a 0.47 μF capacitor connected between its access pin and ground.

Note that for best performance, the LDO bypass capacitors must be placed in close proximity to the device.

## APPLICATIONS INFORMATION

### THERMAL PERFORMANCE

**Table 18. Thermal Parameters for the 40-Lead LFCSP Package**

Symbol	Thermal Characteristic Using a JEDEC51-7 Plus JEDEC51-5 2S2P Test Board <sup>1</sup>	Value <sup>2</sup>	Unit
$\theta_{JA}$	Junction-to-ambient thermal resistance, 0.0 m/sec airflow per JEDEC JESD51-2 (still air)	45	°C/W
$\theta_{JMA}$	Junction-to-ambient thermal resistance, 1.0 m/sec airflow per JEDEC JESD51-6 (moving air)	40	°C/W
$\theta_{JMA}$	Junction-to-ambient thermal resistance, 2.5 m/sec airflow per JEDEC JESD51-6 (moving air)	36	°C/W
$\theta_{JB}$	Junction-to-board thermal resistance, 1.0 m/sec airflow per JEDEC JESD51-8 (moving air)	28	°C/W
$\theta_{JC}$	Junction-to-case thermal resistance (die-to-heat sink) per MIL-Std 883, Method 1012.1	8	°C/W
$\Psi_{JT}$	Junction-to-top-of-package characterization parameter, 0 m/sec airflow per JEDEC JESD51-2 (still air)	0.6	°C/W

<sup>1</sup> The exposed pad on the bottom of the package must be soldered to ground to achieve the specified thermal performance.

<sup>2</sup>Results are from simulations. The PCB is a JEDEC multilayer type. Thermal performance for actual applications requires careful inspection of the conditions in the application to determine if they are similar to those assumed in these calculations.

The AD9551 is specified for a case temperature ( $T_{CASE}$ ). To ensure that  $T_{CASE}$  is not exceeded, an airflow source can be used. Use the following equation to determine the junction temperature on the application PCB:

$$T_J = T_{CASE} + (\Psi_{JT} \times PD)$$

where:

$T_J$  is the junction temperature (°C).

$T_{CASE}$  is the case temperature (°C) measured by the customer at the top center of the package.

$\Psi_{JT}$  is the value indicated in Table 18.

$PD$  is the power dissipation (see the Power Consumption section).

Values of  $\theta_{JA}$  are provided for package comparison and PCB design considerations.  $\theta_{JA}$  can be used for a first-order approximation of  $T_J$  using the following equation:

$$T_J = T_A + (\theta_{JA} \times PD)$$

where  $T_A$  is the ambient temperature (°C).

Values of  $\theta_{JC}$  are provided for package comparison and PCB design considerations when an external heat sink is required.

Values of  $\theta_{JB}$  are provided for package comparison and PCB design considerations.

## SERIAL CONTROL PORT

The AD9551 serial control port is a flexible, synchronous, serial communications port that allows an easy interface to many industry-standard microcontrollers and microprocessors. Single or multiple byte transfers are supported, as well as MSB first or LSB first transfer formats. The AD9551 serial control port is configured for a single bidirectional I/O pin (SDIO only).

The serial control port has two types of registers: read-only and buffered. Read-only registers are nonbuffered and ignore write commands. All writable registers are buffered (also referred to as mirrored) and require an I/O update to transfer the new values from a temporary buffer on the chip to the actual register. To invoke an I/O update, write a 1 to the I/O update bit found in Register 0x05[0]. Because any number of bytes of data can be changed before issuing an update command, the update simultaneously enables all register changes occurring since any previous update.

### SERIAL CONTROL PORT PIN DESCRIPTIONS

SCLK (serial data clock) is the serial shift clock. This pin is an input. SCLK is used to synchronize serial control port reads and writes. Write data bits are registered on the rising edge of this clock, and read data bits are registered on the falling edge. This pin is internally pulled down by a 30 k $\Omega$  resistor to ground.

SDIO (digital serial data input/output) is a dual-purpose pin that acts as input only or as an input/output. The AD9551 defaults to bidirectional pins for I/O.

$\overline{\text{CS}}$  (chip select bar) is an active low control that gates the read and write cycles. When  $\overline{\text{CS}}$  is high, SDIO is in a high impedance state. This pin is internally pulled up by a 100 k $\Omega$  resistor to 3.3 V and should not be left floating. See the Operation of the Serial Control Port section on the use of the  $\overline{\text{CS}}$  pin in a communication cycle.

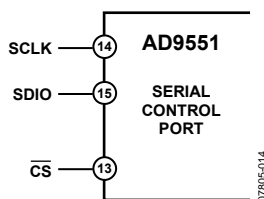

Figure 24. Serial Control Port

### OPERATION OF THE SERIAL CONTROL PORT

#### Framing a Communication Cycle with $\overline{\text{CS}}$

The  $\overline{\text{CS}}$  line gates the communication cycle (a write or a read operation).  $\overline{\text{CS}}$  must be brought low to initiate a communication cycle.

The  $\overline{\text{CS}}$  stall high function is supported in modes where three or fewer bytes of data (plus instruction data) are transferred. Bits[W1:W0] must be set to 00, 01, or 10 (see Table 19). In these modes,  $\overline{\text{CS}}$  may temporarily return high on any byte boundary, allowing time for the system controller to process the next byte.  $\overline{\text{CS}}$  can go high on byte boundaries only and can go high during either part (instruction or data) of the transfer. During this period, the

serial control port state machine enters a wait state until all data has been sent. If the system controller decides to abort before the complete transfer of all the data, the state machine must be reset either by completing the remaining transfer or by returning the  $\overline{\text{CS}}$  line low for at least one complete SCLK cycle (but fewer than eight SCLK cycles). A rising edge on the  $\overline{\text{CS}}$  pin on a nonbyte boundary terminates the serial transfer and flushes the buffer.

Table 19. Byte Transfer Count

W1	W0	Bytes to Transfer (Excluding the 2-Byte Instruction)
0	0	1
0	1	2
1	0	3
1	1	Streaming mode

In the streaming mode (Bits[W1:W0] = 11), any number of data bytes can be transferred in a continuous stream. The register address is automatically incremented or decremented (see the MSB/LSB First Transfers section).  $\overline{\text{CS}}$  must be raised at the end of the last byte to be transferred, thereby ending the stream mode.

#### Communication Cycle—Instruction Plus Data

There are two parts to a communication cycle with the AD9551. The first part writes a 16-bit instruction word into the AD9551, coincident with the first 16 SCLK rising edges. The instruction word provides the AD9551 serial control port with information regarding the data transfer, which is the second part of the communication cycle. The instruction word defines whether the upcoming data transfer is a read or a write, the number of bytes in the data transfer, and the starting register address for the first byte of the data transfer.

#### Write

If the instruction word is for a write operation (Bit I15 = 0), the second part is the transfer of data into the serial control port buffer of the AD9551. The length of the transfer (1, 2, or 3 bytes; or streaming mode) is indicated by two bits (Bits[W1:W0]) in the instruction byte. The length of the transfer indicated by (Bits[W1:W0]) does not include the 2-byte instruction.  $\overline{\text{CS}}$  can be raised after each sequence of eight bits to stall the bus (except after the last byte, where it ends the cycle). When the bus is stalled, the serial transfer resumes when  $\overline{\text{CS}}$  is lowered. Stalling on nonbyte boundaries resets the serial control port.

#### Read

If the instruction word is for a read operation (Bit I15 = 1), the next  $N \times 8$  SCLK cycles clock out the data from the address specified in the instruction word, where N is 1, 2, 3, or 4, as determined by Bits[W1:W0]. In this case, 4 is used for streaming mode, where four or more words are transferred per read. The data read back is valid on the falling edge of SCLK.

The default mode of the AD9551 serial control port is bidirectional mode, and the data read back appears on the SDIO pin.

By default, a read request reads the register value that is currently in use by the AD9551. However, setting Register 0x04[0] = 1 causes the buffered registers to be read instead. The buffered registers are the ones that take effect during the next I/O update.

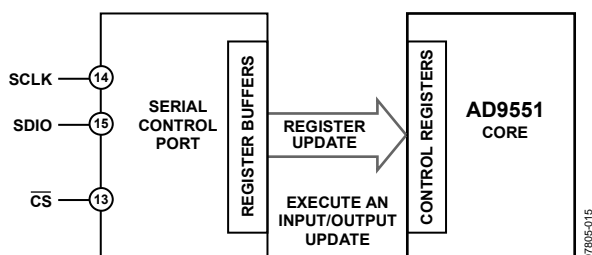

Figure 25. Relationship Between the Serial Control Port Register Buffers and the Control Registers

The AD9551 uses Register 0x00 to Register 0x34. Although the AD9551 serial control port allows both 8-bit and 16-bit instructions, the 8-bit instruction mode provides access to five address bits (Address Bits[A4:A0]) only, which restricts its use to Address Space 0x00 to Address Space 0x01. The AD9551 defaults to 16-bit instruction mode on power-up, and the 8-bit instruction mode is not supported.

### INSTRUCTION WORD (16 BITS)

The MSB of the instruction word (see Table 20) is  $R/\overline{W}$ , which indicates whether the instruction is a read or a write. The next two bits, W1 and W0, are the transfer length in bytes. The final 13 bits are the address bits (Address Bits[A12:A0]) at which the read or write operation is to begin.

For a write, the instruction word is followed by the number of bytes of data indicated Bits[W1:W0], which is interpreted according to Table 19.

Address Bits[A12:A0] select the address within the register map that is written to or read from during the data transfer portion of the communication cycle. The AD9551 uses all of the 13-bit address space. For multibyte transfers, this address is the starting byte address.

Table 20. Serial Control Port, 16-Bit Instruction Word, MSB First

MSB													LSB		
I15	I14	I13	I12	I11	I10	I9	I8	I7	I6	I5	I4	I3	I2	I1	I0
$R/\overline{W}$	W1	W0	A12	A11	A10	A9	A8	A7	A6	A5	A4	A3	A2	A1	A0

Table 21. Definition of Terms Used in Serial Control Port Timing Diagrams

Parameter	Description
$t_{CLK}$	Period of SCLK
$t_{DV}$	Read data valid time (time from falling edge of SCLK to valid data on SDIO)
$t_{DS}$	Setup time between data and rising edge of SCLK
$t_{DH}$	Hold time between data and rising edge of SCLK
$t_S$	Setup time between $\overline{CS}$ and SCLK
$t_H$	Hold time between $\overline{CS}$ and SCLK
$t_{HIGH}$	Minimum period that SCLK should be in a logic high state
$t_{LOW}$	Minimum period that SCLK should be in a logic low state

### MSB/LSB FIRST TRANSFERS

The AD9551 instruction word and byte data can be MSB first or LSB first. The default for the AD9551 is MSB first. The LSB first mode can be set by writing a 1 to Register 0x00[6] and requires that an I/O update be executed. Immediately after the LSB first bit is set, all serial control port operations are changed to LSB first order.

When MSB first mode is active, the instruction and data bytes must be written from MSB to LSB. Multibyte data transfers in MSB first format start with an instruction byte that includes the register address of the most significant data byte. Subsequent data bytes must follow in order from high address to low address. In MSB first mode, the serial control port internal address generator decrements for each data byte of the multibyte transfer cycle.

When LSB first = 1 (LSB first), the instruction and data bytes must be written from LSB to MSB. Multibyte data transfers in LSB first format start with an instruction byte that includes the register address of the least significant data byte followed by multiple data bytes. The serial control port internal byte address generator increments for each data byte of the multibyte transfer cycle.

The AD9551 serial control port register address decrements from the register address just written toward 0x00 for multibyte I/O operations if the MSB first mode is active (default). If the LSB first mode is active, the serial control port register address increments from the address just written toward 0x34 for multibyte I/O operations.

Unused addresses are not skipped during multibyte I/O operations. The user should write the default value to a reserved register and should write only zeros to unmapped registers. Note that it is more efficient to issue a new write command than to write the default value to more than two consecutive reserved (or unmapped) registers.

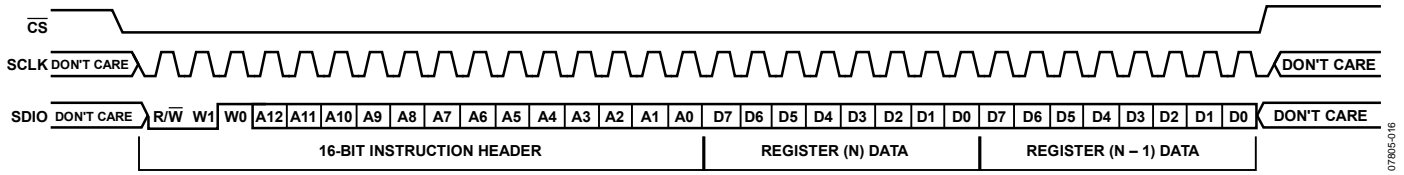

Figure 26. Serial Control Port Write—MSB First, 16-Bit Instruction, Two Bytes Data

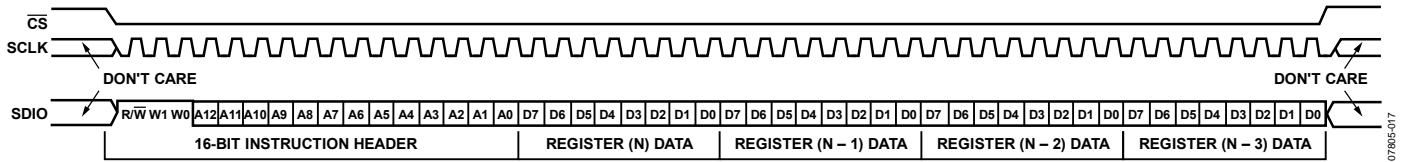

Figure 27. Serial Control Port Read—MSB First, 16-Bit Instruction, Four Bytes Data

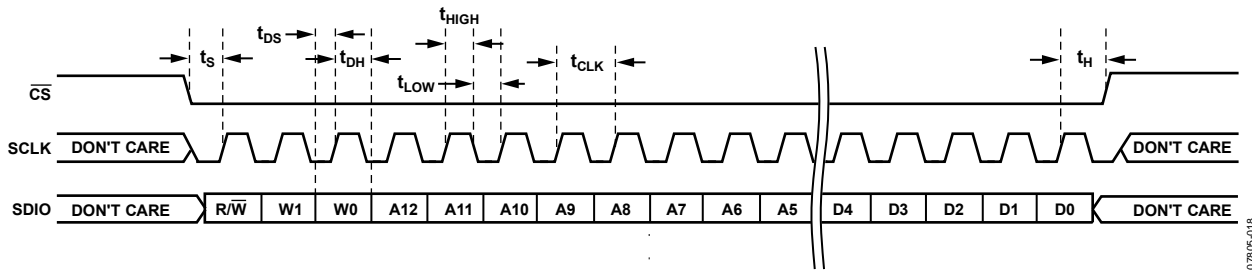

Figure 28. Serial Control Port Write—MSB First, 16-Bit Instruction, Timing Measurements

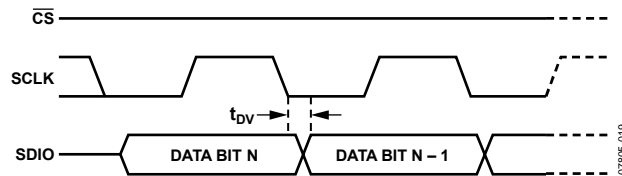

Figure 29. Timing Diagram for Serial Control Port Register Read

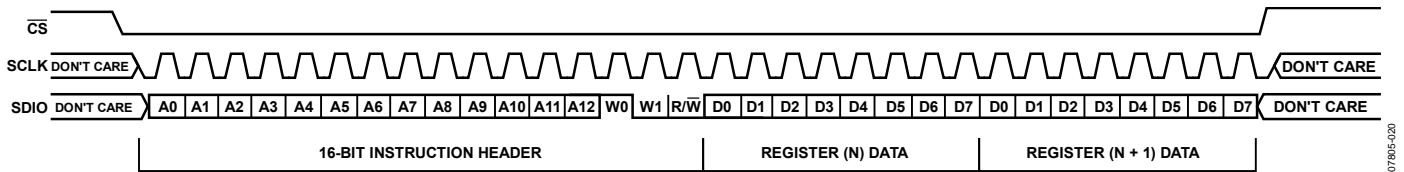

Figure 30. Serial Control Port Write—LSB First, 16-Bit Instruction, Two Bytes Data

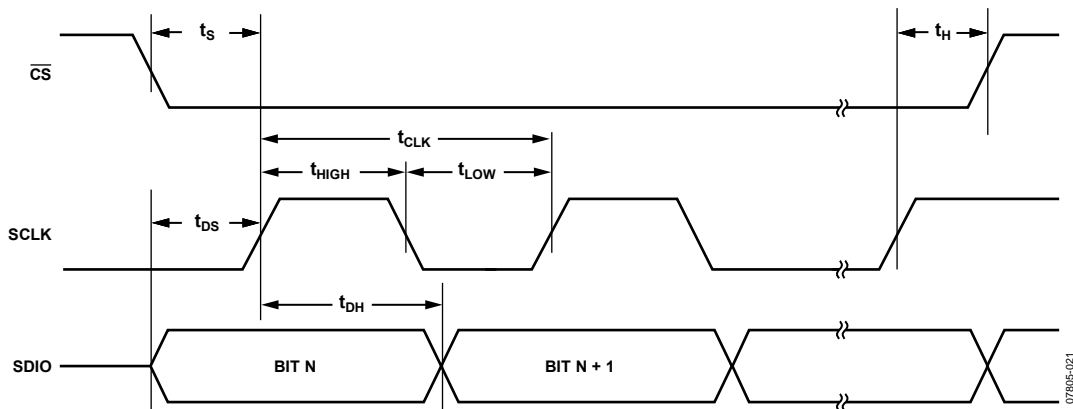

Figure 31. Serial Control Port Timing—Write

## REGISTER MAP

A bit that is labeled “aclr” is an active high, autoclearing bit. When set to a Logic 1 state, the control logic automatically returns it to a Logic 0 state upon completion of the indicated task.

**Table 22. Register Map**

Addr. (Hex)	Register Name	(MSB) Bit 7	Bit 6	Bit 5	Bit 4	Bit 3	Bit 2	Bit 1	(LSB) Bit 0	Default	
0x00	Serial port control	0	LSB first	Soft reset (aclr)	1	1	Device reset	LSB first	0	0x18	
0x04	Readback control	Unused	Unused	Unused	Unused	Unused	Unused	Unused	Readback control	0x00	
0x05	I/O update	Unused	Unused	Unused	Unused	Unused	Unused	Unused	I/O update (aclr)	0x00	
0x0A	Output PLL PFD and charge pump	Output PLL PDF and charge pump current control[7:0] (3.5 $\mu$ A granularity, ~900 $\mu$ A full scale)								0x80	
0x0B	Output PLL PFD and charge pump	Enable SPI control of charge pump current	Enable SPI control of antibacklash period	CP mode[1:0]		Enable CP mode control	PFD feedback input edge control	PFD reference input edge control	Force VCO to midpoint frequency	0x30	
0x0C	Output PLL PFD and charge pump	Unused	CP offset current polarity	CP offset current[1:0]		Enable CP offset current control	Reserved/enable PFD up divide-by-2	Reserved/enable PFD down divide-by-2	Reserved/enable feedback divide-by-2	0x00	
0x0D	Output PLL PFD and charge pump	Antibacklash control[1:0]		Unused	Unused	Unused	Unused	Unused	Output PLL lock detector power-down	0x00	
0x0E	VCO control	Calibrate VCO (aclr)	Enable automatic level control	Automatic level control threshold[2:0]			Enable SPI control of VCO calibration	Boost VCO supply	Enable SPI control of VCO band setting	0x70	
0x0F	VCO control	VCO level control[5:0]						Unused	Unused	0x80	
0x10	VCO control	VCO band control[6:0]							Unused	0x80	
0x11	Output PLL control	N[7:0] (output SDM integer part)								0x00	
0x12	Output PLL control	MOD[19:12] (output SDM modulus)								0x80	
0x13	Output PLL control	MOD[11:4] (output SDM modulus)								0x00	
0x14	Output PLL control	MOD[3:0] (output SDM modulus)				Enable SPI control of output frequency	Bypass output SDM	Disable output SDM	Reset output PLL	0x00	
0x15	Output PLL control	FRAC[19:12] (output SDM fractional part)								0x20	
0x16	Output PLL control	FRAC[11:4] (output SDM fractional part)								0x00	
0x17	Output PLL control	FRAC[3:0] (output SDM fractional part)			Enable OUTPUT PLL LOCKED pin as test port	Test mux control[1:0]		P <sub>1</sub> divider[5]		0x01	
0x18	Output PLL control	P <sub>1</sub> divider[4:0]					P <sub>0</sub> divider[2:0]				0x00

# AD9551

Addr. (Hex)	Register Name	(MSB) Bit 7	Bit 6	Bit 5	Bit 4	Bit 3	Bit 2	Bit 1	(LSB) Bit 0	Default
0x19	Output PLL control	Enable SPI control of OUT1 dividers	Enable SPI control of OUT2 divider	P <sub>2</sub> divider[5:0]						0x20
0x1A	Input receiver and band gap	Receiver reset (aclr)	Band gap voltage adjust[4:0] (00000 = maximum, 11111 = minimum)				Enable receiver power-down	Enable SPI control of band gap voltage	0x00	
0x1B	DCXO control	Disable SPI control of DCXO tuning capacitor	Enable SPI control of DCXO varactor	DCXO tuning capacitor control[5:0]						0x80
0x1C	DCXO control	DCXO varactor control[12:5]								0x00
0x1D	DCXO control	DCXO varactor control[4:0]				Select 2× frequency multiplier	DCXO bypass	Unused	0x00	
0x1E	REFA frequency	Enable SPI control of REFA SDM	Bypass REFA SDM	Enable REFA SDM	Enable REFB	Unused	Disable REF SDM PRBS	Select 19.44 MHz input mode divider	0x30	
0x1F	REFA frequency	FRACA[19:12] (REFA SDM fractional part)								0x40
0x20	REFA frequency	FRACA[11:4] (REFA SDM fractional part)								0x00
0x21	REFA frequency	FRACA[3:0] (REFA SDM fractional part)			Unused	Unused	Unused	Unused	0x00	
0x22	REFA frequency	NA[5:0] (REFA SDM integer part)					Unused	Unused	0x40	
0x23	REFA frequency	Must be 0	MODA[18:12] (REFA SDM modulus)						0x80	
0x24	REFA frequency	MODA[11:4] (REFA SDM modulus)								0x00
0x25	REFA frequency	MODA[3:0] (REFA SDM modulus)			Unused	Unused	Unused	Unused	0x00	
0x26	REFB frequency	Enable SPI control of REFB SDM	Bypass REFB SDM	Enable REFB SDM	Enable REFA	Unused	Unused	Unused	0x30	
0x27	REFB frequency	FRACB[19:12] (REFB SDM fractional part)								0x40
0x28	REFB frequency	FRACB[11:4] (REFB SDM fractional part)								0x00
0x29	REFB frequency	FRACB[3:0] (REFB SDM fractional part)			Unused	Unused	Unused	Unused	0x00	
0x2A	REFB frequency	NB[5:0] (REFB SDM integer part)					Unused	Unused	0x40	
0x2B	REFB frequency	Must be 0	MODB[18:12] (REFB SDM modulus)						0x80	
0x2C	REFB frequency	MODB[11:4] (REFB SDM modulus)								0x00
0x2D	REFB frequency	MODB[3:0] (REFB SDM modulus)			Unused	Unused	Unused	Unused	0x00	

Addr. (Hex)	Register Name	(MSB) Bit 7	Bit 6	Bit 5	Bit 4	Bit 3	Bit 2	Bit 1	(LSB) Bit 0	Default
0x2E	REFA delay	Enable SPI control of REFA delay	REFA delay control[8:2]							0x40
0x2F	REFA delay	REFA delay control[1:0]	Unused	Unused	Unused	Unused	Unused	Unused	Unused	0x00
0x30	REFB delay	Enable SPI control of REFB delay	REFB delay control[8:2]							0x40
0x31	REFB delay	REFB delay control[1:0]	Unused	Unused	Unused	Unused	Unused	Unused	Unused	0x00
0x32	OUT1 driver control	OUT1 drive strength	OUT1 power-down	OUT1 mode control[2:0]		OUT1 CMOS polarity[1:0]		Enable SPI control of OUT1 driver control	0xA8	
0x33	Input PLL control	Loop filter sample rate control	Select 2x frequency divider	Select crystal frequency[1:0]		Unused	Unused	Unused	0x00	
0x34	OUT2 driver control	OUT2 drive strength	OUT2 power-down	OUT2 mode control[2:0]		OUT2 CMOS polarity[1:0]		Enable SPI control of OUT2 driver control	0xA8	

# AD9551

## REGISTER MAP DESCRIPTIONS

Control bit functions are active high, and register address values are always hexadecimal, unless otherwise noted.

### Serial Port Control (Register 0x00 to Register 0x05)

Table 23.

Address	Bit	Bit Name	Description
0x00	7	Unused	Forced to Logic 0 internally, which enables 3-wire mode only.
	6	LSB first	Bit order for SPI port. 0 = most significant bit and byte first (default). 1 = least significant bit and byte first.
	5	Soft reset	Software initiated reset (register values set to default). This is an autoclearing bit.
	4	Unused	Forced to Logic 1 internally, which enables 16-bit mode (the only mode supported by the device).
	[3:0]	Unused	Mirrored version of the contents of Register 0x00[7:4] (that is, Bits[3:0] = Bits[7:4]).
0x04	[7:1]	Unused	Unused.
	0	Readback control	For buffered registers, serial port readback reads from actual (active) registers instead of from the buffer. 0 = reads values currently applied to the internal logic of the device (default). 1 = reads buffered values that take effect on next assertion of I/O update.
0x05	[7:1]	Unused	Unused.
	0	I/O update	Writing a 1 to this bit transfers the data in the serial I/O buffer registers to the internal control registers of the device. This is an autoclearing bit.

### Output PLL PFD and Charge Pump Control (Register 0x0A to Register 0x0D)

Table 24.

Address	Bit	Bit Name	Description
0x0A	[7:0]	Output PLL PFD and charge pump current control	These bits set the magnitude of the output PLL charge pump current. The granularity is ~3.5 $\mu$ A with a full-scale magnitude of ~900 $\mu$ A. Register 0x0A is ineffective unless Register 0x0B[7] = 1. Default is 0x80, or ~448 $\mu$ A.
0x0B	7	Enable SPI control of charge pump current	Controls functionality of Register 0x0A. 0 = the device automatically controls the charge pump current (default). 1 = charge pump current defined by Register 0x0A.
	6	Enable SPI control of antibacklash period	Controls functionality of Register 0x0D[7:6]. 0 = the device automatically controls the antibacklash period (default). 1 = antibacklash period defined by Register 0x0D[7:6].
	[5:4]	CP mode	Controls the mode of the output PLL charge pump. 00 = tristate. 01 = pump up. 10 = pump down. 11 = normal (default).
	3	Enable CP mode control	Controls functionality Bits[5:4] (CP mode). 0 = the device automatically controls the charge pump mode (default). 1 = charge pump mode is defined by Bits[5:4].
	2	PFD feedback input edge control	Selects the polarity of the active edge of the output PLL's feedback input. 0 = positive edge (default). 1 = negative edge.
	1	PFD reference input edge control	Selects the polarity of the active edge of the output PLL's reference input. 0 = positive edge (default). 1 = negative edge.
	0	Force VCO to midpoint frequency	Selects VCO control voltage functionality. 0 = normal VCO operation (default). 1 = force VCO control voltage to midscale.

Address	Bit	Bit Name	Description
0x0C	7	Unused	Unused.
	6	CP offset current polarity	Selects the polarity of the charge pump offset current of the output PLL. 0 = pump up (default). 1 = pump down. This bit is ineffective unless Bit 3 = 1.
	[5:4]	CP offset current	Controls the magnitude of the charge pump offset current of the output PLL as a fraction of the value in Register 0x0A. Ineffective unless Bit 3 = 1. 00 = 1/2 (default). 01 = 1/4. 10 = 1/8. 11 = 1/16.
	3	Enable CP offset current control	Controls functionality of Bits[6:4]. 0 = the device automatically controls charge pump offset current (default). 1 = charge pump offset current defined by Bits[6:4].
	2	Reserved	Enables PFD up divide-by-2 (reserved for test).
	1	Reserved	Enables PFD down divide-by-2 (reserved for test).
	0	Reserved	Enables feedback divide-by-2 (reserved for test).
0x0D	[7:6]	Antibacklash control	Controls the PFD antibacklash period of the output PLL. 00 = minimum (default). 01 = low. 10 = high. 11 = maximum. These bits are ineffective unless Register 0x0B[6] = 1.
	[5:1]	Unused	Unused.
	0	Output PLL lock detector power-down	Controls power-down of the output PLL's lock detector. 0 = lock detector active (default). 1 = lock detector powered down.

### VCO Control (Register 0x0E to Register 0x10)

Table 25.

Address	Bit	Bit Name	Description
0x0E	7	Calibrate VCO	Initiates VCO calibration (this is an autoclearing bit). This bit is ineffective unless Bit 2 = 1.
	6	Enable automatic level control	Enables automatic level control of the VCO. 0 = VCO level defined by Register 0x0F[7:2]. 1 = the device automatically controls the VCO level (default).
	[5:3]	Automatic level control threshold	Controls the VCO threshold detector level. The default is 110. Note that the functionality of Bit 4 is inverted; that is, the minimum is 010, and the maximum is 101.
	2	Enable SPI control of VCO calibration	Enables functionality of Bit 7. 0 = the device automatically performs VCO calibration (default). 1 = Bit 7 controls VCO calibration.
	1	Boost VCO supply	Selects VCO supply voltage. 0 = normal supply voltage (default). 1 = increase supply voltage by 100 mV.
	0	Enable SPI control of VCO band setting	Controls VCO band setting functionality. 0 = the device automatically selects the VCO band (default). 1 = VCO band defined by Register 0x10[7:1].
0x0F	[7:2]	VCO level control	Controls the VCO amplitude from minimum (00 0000) to maximum (11 1111). The default is 10 0000. These bits are ineffective unless Register 0x0E[6] = 0.
	[1:0]	Unused	Unused.
0x10	[7:1]	VCO band control	Controls the VCO frequency band from minimum (000 0000) to maximum (111 1111). The default is 100 0000.
	0	Unused	Unused.

# AD9551

## Output PLL Control (Register 0x11 to Register 0x19)

Table 26.

Address	Bit	Bit Name	Description
0x11	[7:0]	N	8-bit integer divide value for the output SDM. Default is 0x00. Note that operational limitations impose a lower boundary of 64 (0x40) on N.
0x12	[7:0]	MOD	Bits[19:12] of the 20-bit modulus of the output SDM.
0x13	[7:0]	MOD	Bits[11:4] of the 20-bit modulus of the output SDM.
0x14	[7:4]	MOD	Bits[3:0] of the 20-bit modulus of the output SDM. Default is MOD = 1000 0000 0000 0000 0000 (524,288).
	3	Enable SPI control of output frequency	Controls output frequency functionality. 0 = output frequency defined by the Y[3:0] pins (default). 1 = contents of Register 0x11 to Register 0x17 define output frequency via N, MOD, and FRAC.
	2	Bypass output SDM	Controls bypassing of the output SDM. 0 = allow integer-plus-fractional division (default). 1 = allow only integer division.
	1	Disable output SDM	Controls the output SDM internal clocks. 0 = normal operation (SDM clocks active) (default). 1 = SDM disabled (SDM clocks stopped).
	0	Reset output PLL	Controls initialization of the output PLL. 0 = normal operation (default). 1 = resets the counters and logic associated with the output PLL but does not affect the output dividers.
0x15	[7:0]	FRAC	Bits[19:12] of the 20-bit fractional part of the output SDM.
0x16	[7:0]	FRAC	Bits[11:4] of the 20-bit fractional part of the output SDM.
0x17	[7:4]	FRAC	Bits[3:0] of the 20-bit fractional part of the output SDM. Default is FRAC = 0010 0000 0000 0000 0000 (131,072).
	3	Enable OUTPUT PLL LOCKED pin as test port	Controls functionality of the OUTPUT PLL LOCKED pin (Pin 26). 0 = OUTPUT PLL LOCKED pin indicates status of PLL lock detector (default). 1 = OUTPUT PLL LOCKED pin indicates the signal defined by Bits[2:1].
	[2:1]	Test mux control	Selects test mux output. 00 = front end test clock (default). 01 = PFD up divide-by-2. 10 = PFD down divide-by-2. 11 = PLL feedback divide-by-2. These bits are ineffective unless Bit 3 = 1.
	0	P <sub>1</sub> divider	Bit 5 of the 6-bit P <sub>1</sub> divider for OUT1.
0x18	[7:3]	P <sub>1</sub> divider	Bits[4:0] of the 6-bit P <sub>1</sub> divider for OUT1 (1 ≤ P <sub>1</sub> ≤ 63). Do not set these bits to 000000. Default is P <sub>1</sub> = 100000 (32). The P <sub>1</sub> bits are ineffective unless Register 0x19[7] = 1.
	[2:0]	P <sub>0</sub> divider	Bits[2:0] of the 3-bit P <sub>0</sub> divider for OUT1. The P <sub>0</sub> divide value is as follows: 000 = 4 (default). 001 = 5. 010 = 6. 011 = 7. 100 = 8. 101 = 9. 110 = 10. 111 = 11. The P <sub>0</sub> bits are ineffective unless Register 0x19[7] = 1.
0x19	7	Enable SPI control of OUT1 dividers	Controls functionality of OUT1 dividers. 0 = OUT1 dividers defined by the Y[3:0] pins (default). 1 = contents of Register 0x17 and Register 0x18 define OUT1 dividers (P <sub>0</sub> and P <sub>1</sub> ).
	6	Enable SPI control of OUT2 divider	Controls functionality of OUT2 divider. 0 = OUT2 divider defined by the Y[3:0] pins (P <sub>2</sub> = 1) (default). 1 = contents of Bits[5:0] define P <sub>2</sub> .
	[5:0]	P <sub>2</sub> divider	Bits[5:0] of the 6-bit P <sub>2</sub> divider for OUT2 (1 ≤ P <sub>2</sub> ≤ 63). Do not set these bits to 000000. Default is P <sub>2</sub> = 100000 (32). The P <sub>2</sub> bits are ineffective unless Register 0x19[6] = 1.

**Input Receiver and Band Gap (Register 0x1A)**

Table 27.

Address	Bit	Bit Name	Description
0x1A	7	Receiver reset	Input receiver reset control. This is an autoclearing bit. 0 = normal operation (default). 1 = reset input receiver logic.
	[6:2]	Band gap voltage adjust	Controls the band gap voltage setting from minimum (0 0000) to maximum (1 1111). Default is 0 0000.
	1	Enable receiver power-down	Controls the option to power down the REFA and/or REFB receiver via Register 0x26[4] and Register 0x1E[4], respectively. 0 = option disabled (default). 1 = option enabled.
	0	Enable SPI control of band gap voltage	Enables functionality of Bits[6:2]. 0 = the device automatically selects receiver band gap voltage (default). 1 = Bits[6:2] define the receiver band gap voltage.

**DCXO Control (Register 0x1B to Register 0x1D)**

Table 28.

Address	Bit	Bit Name	Description
0x1B	7	Disable SPI control of DCXO tuning capacitor	Disables functionality of Bits[5:0]. 0 = tuning capacitance defined by Bits[5:0]. 1 = the device automatically selects DCXO tuning capacitance (default).
	6	Enable SPI control of DCXO varactor	Enables functionality of Register 0x1C and Register 0x1D[7:3]. 0 = the device automatically selects DCXO varactor (default). 1 = varactor defined by Register 0x1C[7:0] and Register 0x1D[7:3].
	[5:0]	DCXO tuning capacitor control	Higher binary values correspond to smaller total capacitance, resulting in a higher operating frequency. Default is 00 0000.
0x1C	[7:0]	DCXO varactor control	Bits[12:5] of the 13-bit varactor control word.
0x1D	[7:3]	DCXO varactor control	Bits[4:0] of the 13-bit varactor control word. The default varactor control word is 0 0000 0000 0000.
	2	Select 2× frequency multiplier	Select/bypass the 2× frequency multiplier. 0 = bypassed (default). 1 = selected.
	1	DCXO bypass	Select/bypass the DCXO. 0 = selected (default). 1 = bypassed.
	0	Unused	Unused.

# AD9551

## REFA Frequency Control (Register 0x1E to Register 0x25)

Table 29.

Address	Bit	Bit Name	Description
0x1E	7	Enable SPI control of REFA SDM	Controls REFA frequency division functionality. 0 = REFA frequency division, as defined by the A[3:0] pins (default). 1 = contents of Register 0x1F to Register 0x25 define REFA frequency division via NA, MODA, and FRACA.
	6	Bypass REFA SDM	Controls bypassing of the REFA SDM. 0 = allow integer-plus-fractional division (default). 1 = allow only integer division.
	5	Enable REFA SDM	Controls REFA SDM enable and hold functionality. 0 = reset REFA SDM and stop its clocks. 1 = REFA SDM enabled (default).
	4	Enable REFB	Controls REFB enable and power-down functionality. 0 = power down REFB input receiver (ineffective unless Register 0x1A[1] = 1). 1 = normal operation (default).
	3	Unused	Unused.
	2	Disable REF SDM PRBS	Controls the PRBS generator for both the REFA and REFB SDMs. 0 = PRBS generator enabled (default). 1 = PRBS generator disabled.
	[1:0]	Select 19.44 MHz input mode divider	Selects the divider value when the 19.44 MHz input mode is in effect. 00 = 1 (default). 01 = 1. 10 = 2. 11 = 4. These bits are ineffective unless the A[3:0] pins = 1111 or the B[3:0] pins = 1111.
0x1F	[7:0]	FRACA	Bits[19:12] of the 20-bit fractional part of the REFA SDM.
0x20	[7:0]	FRACA	Bits[11:4] of the 20-bit fractional part of the REFA SDM.
0x21	[7:4]	FRACA	Bits[3:0] of the 20-bit fractional part of the REFA SDM. Default is FRACA = 0100 0000 0000 0000 (262,144). Note that FRACA assumes twos complement format.
	[3:0]	Unused	Unused.
0x22	[7:2]	NA	6-bit integer divide value for the REFA SDM. Default divide value is 16.
	[1:0]	Unused	Unused.
0x23	7	Unused	This bit must be programmed to 0, even though the default value is 1.
	[6:0]	MODA	Bits[18:12] of the 19-bit modulus of the REFA SDM.
0x24	[7:0]	MODA	Bits[11:4] of the 19-bit modulus of the REFA SDM.
0x25	[7:4]	MODA	Bits[3:0] of the 19-bit modulus of the REFA SDM. Default is MODA = 000 0000 0000 0000.
	[3:0]	Unused	Unused.

**REFB Frequency Control (Register 0x26 to Register 0x2D)**

Table 30.

Address	Bit	Bit Name	Description
0x26	7	Enable SPI control of REFB SDM	Controls REFB frequency division functionality. 0 = REFB frequency division defined by the B[3:0] pins (default). 1 = contents of Register 0x27 to Register 0x2D define REFB frequency division via NB, MODB, and FRACB.
	6	Bypass REFB SDM	Controls bypassing of the REFB SDM. 0 = allow integer-plus-fractional division (default). 1 = allow integer division only.
	5	Enable REFB SDM	Controls REFB SDM enable and hold functionality. 0 = reset REFB SDM and stop its clocks. 1 = REFB SDM enabled (default).
	4	Enable REFA	Controls REFA enable and power-down functionality. 0 = power down REFA input receiver (ineffective unless Register 0x1A[1] = 1). 1 = normal operation (default).
	[3:0]	Unused	Unused.
0x27	[7:0]	FRACB	Bits[19:12] of the 20-bit fractional part of the REFB SDM.
0x28	[7:0]	FRACB	Bits[11:4] of the 20-bit fractional part of the REFB SDM.
0x29	[7:4]	FRACB	Bits[3:0] of the 20-bit fractional part of the REFB SDM. Default is FRACB = 0100 0000 0000 0000 (262,144). Note that FRACB assumes twos complement format.
	[3:0]	Unused	Unused.
0x2A	[7:2]	NB	6-bit integer divide value for the REFB SDM. Default divide value is 8.
	[1:0]	Unused	Unused.
0x2B	7	Unused	This bit must be programmed to 0, even though the default value is 1.
	[6:0]	MODB	Bits[18:12] of the 19-bit modulus of the REFB SDM.
0x2C	[7:0]	MODB	Bits[11:4] of the 19-bit modulus of the REFB SDM.
0x2D	[7:4]	MODB	Bits[3:0] of the 19-bit modulus of the REFB SDM. Default is MODB = 000 0000 0000 0000 0000.
	[3:0]	Unused	Unused.

**REFA Delay Control (Register 0x2E and Register 0x2F)**

Table 31.

Address	Bit	Bit Name	Description
0x2E	7	Enable SPI control of REFA delay	Controls REFA delay functionality. 0 = the device automatically selects REFA delay (default). 1 = REFA delay defined by Register 0x2E[6:0] and Register 0x2F[7:6].
	[6:0]	REFA delay control	Bits[8:2] of the 9-bit REFA delay word.
0x2F	[7:6]	REFA delay control	Bits[1:0] of the 9-bit REFA delay word. Default is 1 0000 0000. Delay granularity is ~150 ps.
	[5:0]	Unused	Unused.

**REFB Delay Control (Register 0x30 and Register 0x31)**

Table 32.

Address	Bit	Bit Name	Description
0x30	7	Enable SPI control of REFB delay	Controls REFB delay functionality: 0 = the device automatically selects REFB delay (default). 1 = REFB delay defined by Register 0x30[6:0] and Register 0x31[7:6].
	[6:0]	REFB delay control	Bits[8:2] of the 9-bit REFB delay word.
0x31	[7:6]	REFB delay control	Bits[1:0] of the 9-bit REFB delay word. Default is 1 0000 0000. Delay granularity is ~150 ps.
	[5:0]	Unused	Unused.

# AD9551

## OUT1 Driver Control (Register 0x32)

Table 33.

Address	Bit	Bit Name	Description
0x32	7	OUT1 drive strength	Controls the output drive capability of the OUT1 driver. 0 = weak. 1 = strong (default).
	6	OUT1 power-down	Controls power-down functionality of the OUT1 driver. 0 = OUT1 active (default). 1 = OUT1 powered down.
	[5:3]	OUT1 mode control	OUT1 driver mode selection. 000 = CMOS, both pins active. 001 = CMOS, positive pin active, negative pin tristate. 010 = CMOS, positive pin tristate, negative pin active. 011 = CMOS, both pins tristate. 100 = LVDS. 101 = LVPECL (default). 110 = not used. 111 = not used.
	[2:1]	OUT1 CMOS polarity	Selects the polarity of the OUT1 pins in CMOS mode. 00 = positive pin logic is true = 1, false = 0/negative pin logic is true = 0, false = 1 (default). 01 = positive pin logic is true = 1, false = 0/negative pin logic is true = 1, false = 0. 10 = positive pin logic is true = 0, false = 1/negative pin logic is true = 0, false = 1. 11 = positive pin logic is true = 0, false = 1/negative pin logic is true = 1, false = 0. These bits are ineffective unless Bits[5:3] select CMOS mode.
	0	Enable SPI control of OUT1 driver control	Controls OUT1 driver functionality. 0 = OUT1 is LVDS or LVPECL, per the OUTSEL pin (Pin 16) (default). 1 = OUT1 functionality defined by Bits[7:1].

## Input PLL Control (Register 0x33)

Table 34.

Address	Bit	Bit Name	Description
0x33	7	Loop filter sample rate control	Select/bypass 8× clock divider to the digital loop filter. 0 = selected (default). 1 = bypassed.
	6	Select 2× frequency divider	Select/bypass the 2× frequency divider. 0 = bypassed (default). 1 = selected. Note that this bit is not functional in 19.44 MHz mode.
	[5:4]	Select crystal frequency	Select the crystal frequency for 19.44 MHz mode. 00 = 52.000 MHz (default). 01 = 50.000 MHz. 10 = 49.860 MHz. 11 = 49.152 MHz. Note that these bits are functional only in 19.44 MHz mode.
	[3:0]	Unused	Unused.

**OUT2 Driver Control (Register 0x34)**

Table 35.

Address	Bit	Bit Name	Description
0x34	7	OUT2 drive strength	Controls the output drive capability of the OUT2 driver. 0 = weak. 1 = strong (default).
	6	OUT2 power-down	Controls power-down functionality of the OUT2 driver. 0 = OUT2 active (default). 1 = OUT2 powered down.
	[5:3]	OUT2 mode control	OUT2 driver mode selection. 000 = CMOS, both pins active. 001 = CMOS, positive pin active, negative pin tristate. 010 = CMOS, positive pin tristate, negative pin active. 011 = CMOS, both pins tristate. 100 = LVDS. 101 = LVPECL (default). 110 = not used. 111 = not used.
	[2:1]	OUT2 CMOS polarity	Selects the polarity of the OUT2 pins in CMOS mode. 00 = positive pin logic is true = 1, false = 0/negative pin logic is true = 0, false = 1 (default). 01 = positive pin logic is true = 1, false = 0/negative pin logic is true = 1, false = 0. 10 = positive pin logic is true = 0, false = 1/negative pin logic is true = 0, false = 1. 11 = positive pin logic is true = 0, false = 1/negative pin logic is true = 1, false = 0. These bits are ineffective unless Bits[5:3] select CMOS mode.
	0	Enable SPI control of OUT2 driver control	Controls OUT2 driver functionality. 0 = OUT2 is LVDS or LVPECL, per the OUTSEL pin (Pin 16) (default). 1 = OUT2 functionality defined by Bits[7:1].

## OUTLINE DIMENSIONS

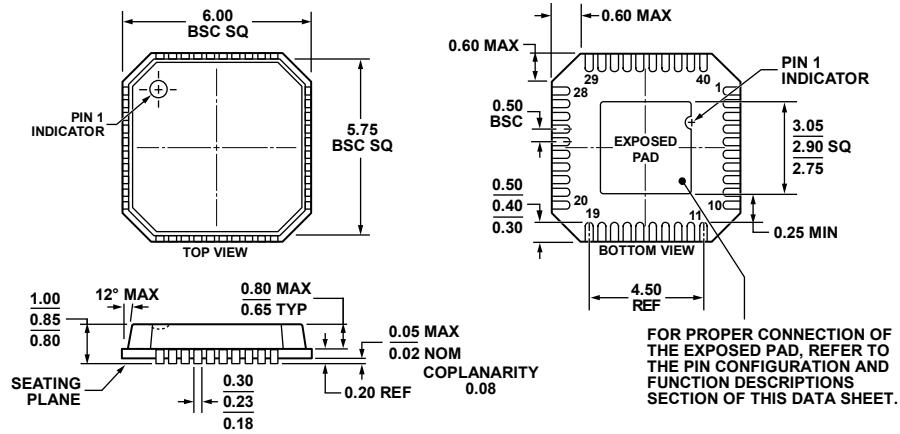

COMPLIANT TO JEDEC STANDARDS MO-220-VJJD-2

Figure 32. 40-Lead Lead Frame Chip Scale Package [LFCSP\_VQ]  
 6 × 6 mm Body, Very Thin Quad  
 (CP-40-8)

Dimensions shown in millimeters

## ORDERING GUIDE

Model	Temperature Range	Package Description	Package Option
AD9551BCPZ <sup>1</sup>	-40°C to +85°C	40-Lead Lead Frame Chip Scale Package [LFCSP_VQ]	CP-40-8
AD9551BCPZ-REEL7 <sup>1</sup>	-40°C to +85°C	40-Lead Lead Frame Chip Scale Package [LFCSP_VQ]	CP-40-8
AD9551/PCBZ <sup>1</sup>		Evaluation Board	

<sup>1</sup> Z = RoHS Compliant Part.

## Looking for pricing, stock, or lifecycle information?

Click below to explore more details on WIN SOURCE:

 [View AD9551BCPZ on WIN SOURCE](#)

 [Analog Devices Inc. Information](#)

## Optimize Your Supply Chain with WIN SOURCE Solutions

-  Global Sourcing Solution
-  Obsolete Management
-  Cost Control Management
-  Shortage Management
-  Alternative Solution
-  Excess Inventory Management