



**THE DATASHEET OF
LTC8043FN8#PBF**



FEATURES

- Improved Direct Replacement for DAC-8043 and MAX543
- **SO-8 Package**
- **DNL and INL Over Temperature: $\pm 0.5\text{LSB}$**
- Easy, Fast and Flexible Serial Interface
- **$\pm 1\text{LSB}$ Maximum Gain Error**
- 4-Quadrant Multiplication
- Low Power Consumption
- Low Cost

APPLICATIONS

- Process Control and Industrial Automation
- Remote Microprocessor-Controlled Systems
- Digitally Controlled Filters and Power Supplies
- Programmable Gain Amplifiers
- Automatic Test Equipment

DESCRIPTION

The LTC[®]8043 is a serial-input 12-bit multiplying digital-to-analog converter (DAC). It is a superior pin compatible replacement for the DAC-8043. Improvements include better accuracy, better stability over temperature and supply variations, lower sensitivity to output amplifier offset, tighter timing specifications and lower output capacitance.

An easy-to-use 3-wire serial interface is well-suited to remote or isolated applications

The LTC8043 is extremely versatile. It can be used for 2-quadrant and 4-quadrant multiplying, programmable gain and single supply applications, such as noninverting voltage output mode.

Parts are available in 8-pin SO and PDIP packages and are specified over the extended industrial temperature range, -40°C to 85°C .

 LTC and LT are registered trademarks of Linear Technology Corporation.

TYPICAL APPLICATION

SO-8 Multiplying DAC Has Easy 3-Wire Serial Interface

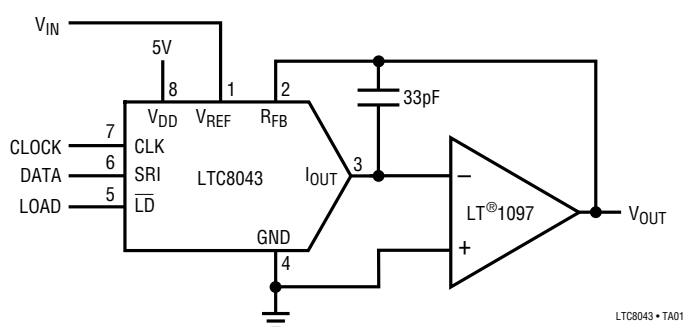

Integral Nonlinearity Over Temperature

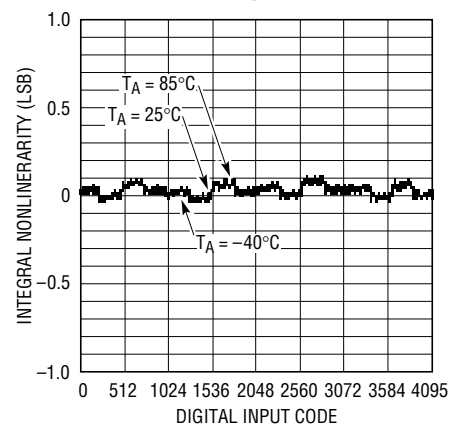

ABSOLUTE MAXIMUM RATINGS

V_{DD} to GND	-0.5V to 7V
Digital Inputs to GND	-0.5V to ($V_{DD} + 0.5V$)
V_{IOUT} to GND	-0.5V to ($V_{DD} + 0.5V$)
V_{REF} to GND	$\pm 25V$
V_{RFB} to GND	$\pm 25V$
Maximum Junction Temperature	150°C
Operating Temperature Range	-40°C to 85°C
Storage Temperature Range	-65°C to 150°C
Lead Temperature (Soldering, 10 sec).....	300°C

PACKAGE/ORDER INFORMATION

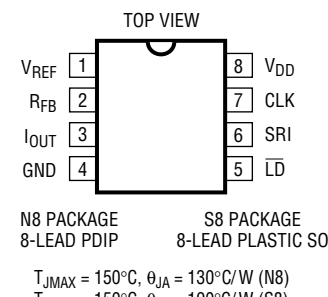
	ORDER PART NUMBER
	LTC8043EN8 LTC8043FN8 LTC8043ES8 LTC8043FS8

Consult factory for Military grade parts.

ACCURACY CHARACTERISTICS

$V_{DD} = 5V$, $V_{REF} = 10V$, $V_{IOUT} = GND = 0V$, $T_A = T_{MIN}$ to T_{MAX} , unless otherwise specified.

SYMBOL	PARAMETER	CONDITIONS	LTC8043E			LTC8043F			UNITS
			MIN	TYP	MAX	MIN	TYP	MAX	
	Resolution		●	12		12		Bits	
INL	Integral Nonlinearity	(Note 1)	●		± 0.5		± 1	LSB	
DNL	Differential Nonlinearity	Guaranteed Monotonic, T_{MIN} to T_{MAX}	●		± 0.5		± 1	LSB	
GE	Gain Error	(Note 2) $T_A = 25^\circ C$ T_{MIN} to T_{MAX}	●		± 1		± 2	LSB	
			●		± 2		± 2	LSB	
	Gain Temperature Coefficient ($\Delta Gain/\Delta Temp$)	(Note 3)	●	1	5	1	5	ppm/°C	
I_{LKG}	Output Leakage Current	(Note 4) $T_A = 25^\circ C$ T_{MIN} to T_{MAX}	●		± 5		± 5	nA	
			●		± 25		± 25	nA	
	Zero-Scale Error	$T_A = 25^\circ C$ T_{MIN} to T_{MAX}	●		± 0.03 ± 0.15		± 0.03 ± 0.15	LSB LSB	
PSRR	Power Supply Rejection Ratio	$V_{DD} = 5V \pm 5\%$	●	± 0.0001	± 0.002	± 0.0001	± 0.002	%/%	

ELECTRICAL CHARACTERISTICS

$V_{DD} = 5V$, $V_{REF} = 10V$, $V_{IOUT} = GND = 0V$, $T_A = T_{MIN}$ to T_{MAX} , unless otherwise specified.

SYMBOL	PARAMETER	CONDITIONS	ALL GRADES			UNITS	
			MIN	TYP	MAX		
Reference Input							
R_{REF}	V_{REF} Input Resistance	(Note 5)	●	7	11	15	k Ω
AC Performance (Note 3)							
	Output Current Settling Time	(Notes 6, 7)	●	0.25	1		μs
	Multiplying Feedthrough Error	$V_{REF} = \pm 10V$, 10kHz Sinewave	●	0.7	1		mV _{P-P}
	Digital-to-Analog Glitch Energy	(Notes 6, 8)	●	2	20		nVSEC
THD	Total Harmonic Distortion	(Note 9)	●	-108	-92		dB
	Output Noise Voltage Density	(Note 10)	●		17		nV/ \sqrt{Hz}
Analog Outputs (Note 3)							
C_{OUT}	Output Capacitance	DAC Register Loaded to All 1s	●	60	90		pF
		DAC Register Loaded to All 0s	●	30	60		pF

ELECTRICAL CHARACTERISTICS

$V_{DD} = 5V$, $V_{REF} = 10V$, $V_{IOUT} = GND = 0V$, $T_A = T_{MIN}$ to T_{MAX} , unless otherwise specified.

SYMBOL	PARAMETER	CONDITIONS	ALL GRADES			UNITS	
			MIN	TYP	MAX		
Digital Inputs							
V_{IH}	Digital Input High Voltage		●	2.4		V	
V_{IL}	Digital Input Low Voltage		●		0.8	V	
I_{IN}	Digital Input Current	$V_{IN} = 0V$ to V_{DD}	●	0.001	± 1	μA	
C_{IN}	Digital Input Capacitance	$V_{IN} = 0V$, (Note 3)	●		8	pF	
Timing Characteristics (Note 3)							
t_{DS}	Serial Input to Clock Setup Time		●	30	-5	ns	
t_{DH}	Serial Input to Clock Hold Time		●	60	25	ns	
t_{SRI}	Serial Input Data Pulse Width		●	80		ns	
t_{CH}	Clock Pulse Width High		●	80		ns	
t_{CL}	Clock Pulse Width Low		●	80		ns	
t_{LD}	Load Pulse Width		●	140		ns	
t_{ASB}	LSB Clocked into Input Register to Load DAC Register Time		●	0		ns	
Power Supply							
V_{DD}	Supply Voltage		●	4.75	5	5.25	V
I_{DD}	Supply Current	Digital Inputs = 0V or V_{DD} Digital Inputs = V_{IH} or V_{IN}	●		100	μA	
			●		500	μA	

The ● denotes specifications which apply over the full operating temperature range.

Note 1: $\pm 0.5LSB = \pm 0.012\%$ of full scale.

Note 2: Using internal feedback resistor.

Note 3: Guaranteed by design, not subject to test.

Note 4: I_{OUT} with DAC register loaded with all 0s.

Note 5: Typical temperature coefficient is 100ppm/°C.

Note 6: I_{OUT} load = 100 Ω in parallel with 13pF.

Note 7: To 0.01% for a full-scale change, measured from falling edge of \overline{LD} .

Note 8: $V_{REF} = 0V$. DAC register contents changed from all 0s to all 1s or from all 1s to all 0s.

Note 9: $V_{REF} = 6V_{RMS}$ at 1kHz. DAC register loaded with all 1s.

Note 10: 10Hz to 100kHz between R_{FB} and I_{OUT} . Calculation from $e_n = \sqrt{4KTRB}$ where: K = Boltzmann constant (J/K°); R = resistance (Ω); T = resistor temperature (°K); B = bandwidth (Hz).

BLOCK DIAGRAM

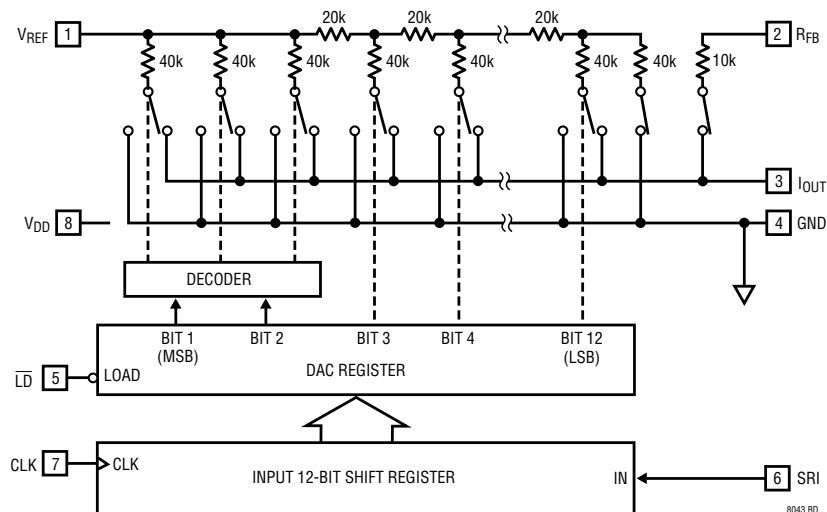

TIMING DIAGRAM

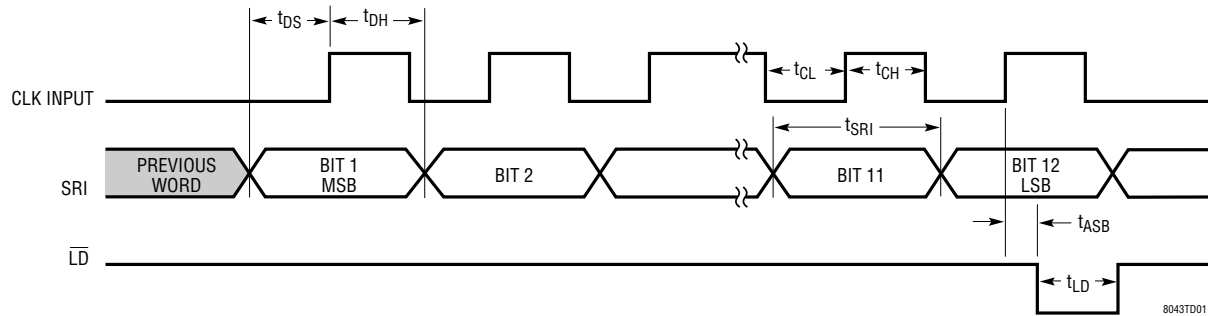

TYPICAL APPLICATIONS

Unipolar Operation (2-Quadrant Multiplication)

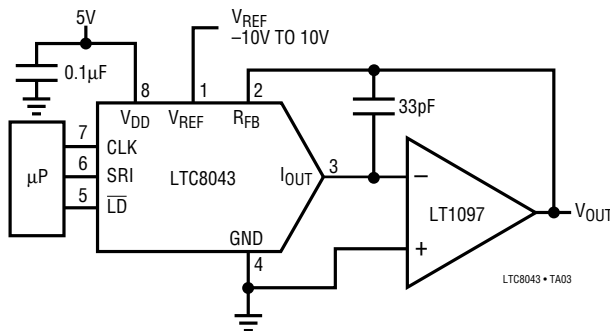

Table 1. Unipolar Binary Code Table

DIGITAL INPUT BINARY NUMBER IN DAC REGISTER		ANALOG OUTPUT V_{OUT}
MSB	LSB	
1111	1111	$-V_{REF}$ (4095/4096)
1000	0000	$-V_{REF}$ (2048/4096) = $-V_{REF}/2$
0000	0001	$-V_{REF}$ (1/4096)
0000	0000	0V

Bipolar Operation (4-Quadrant Multiplication)

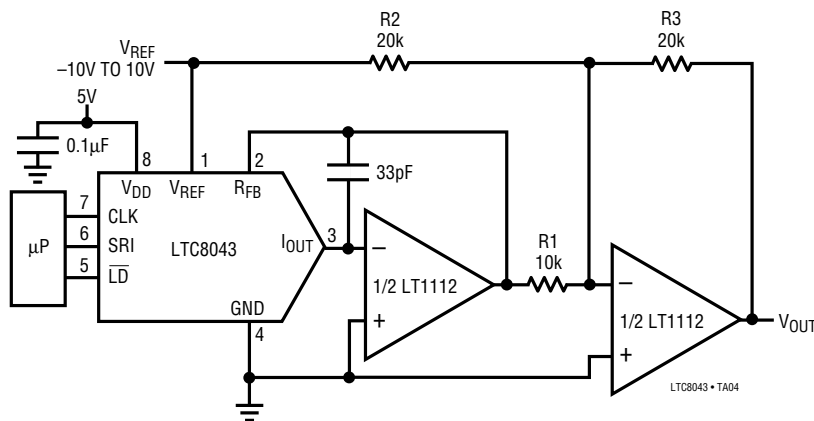

Table 2. Bipolar Offset Binary Code Table

DIGITAL INPUT BINARY NUMBER IN DAC REGISTER		ANALOG OUTPUT V_{OUT}
MSB	LSB	
1111	1111	$+V_{REF}$ (2047/2048)
1000	0001	$+V_{REF}$ (1/2048)
1000	0000	0V
0111	1111	$-V_{REF}$ (1/2048)
0000	0000	$-V_{REF}$ (2048/2048) = $-V_{REF}$

RELATED PARTS

PART NUMBER	DESCRIPTION	COMMENTS
LTC1257	Complete Serial I/O V_{OUT} 12-Bit DAC	5V to 15V Single Supply in 8-Pin SO and PDIP
LTC1451/LTC1452/LTC1453	Complete Serial I/O V_{OUT} 12-Bit DACs	3V/5V Single Supply in 8-Pin SO and PDIP
LTC7541A	Parallel I/O Multiplying 12-Bit DAC	12-Bit Wide Input
LTC7543/LTC8143	Serial I/O Multiplying 12-Bit DACs	Clear Pin and Serial Data Output (LTC8143)

Looking for pricing, stock, or lifecycle information?

Click below to explore more details on WIN SOURCE:

 [View LTC8043FN8#PBF on WIN SOURCE](#)

 [Analog Devices Inc. Information](#)

Optimize Your Supply Chain with WIN SOURCE Solutions

-  Global Sourcing Solution
-  Obsolete Management
-  Cost Control Management
-  Shortage Management
-  Alternative Solution
-  Excess Inventory Management