



**THE DATASHEET OF
AD5696BRUZ**



Quad, 16-/12-Bit nanoDAC+ with I2C Interface

FEATURES

- ▶ High relative accuracy (INL): ± 2 LSB maximum at 16 bits
- ▶ Tiny package: 3 mm \times 3 mm, 16-lead LFCSP
- ▶ Total unadjusted error (TUE): $\pm 0.1\%$ of FSR maximum
- ▶ Offset error: ± 1.5 mV maximum
- ▶ Gain error: $\pm 0.1\%$ of FSR maximum
- ▶ High drive capability: 20 mA, 0.5 V from supply rails
- ▶ User-selectable gain of 1 or 2 (GAIN pin)
- ▶ Reset to zero scale or midscale (RSTSEL pin)
- ▶ 1.8 V logic compatibility
- ▶ 400 kHz I²C-compatible serial interface
- ▶ 4 I²C addresses available
- ▶ Low glitch: 0.5 nV-sec
- ▶ Low power: 1.8 mW at 3 V
- ▶ 2.7 V to 5.5 V power supply
- ▶ -40°C to $+105^{\circ}\text{C}$ temperature range

APPLICATIONS

- ▶ Digital gain and offset adjustment
- ▶ Programmable attenuators
- ▶ Process control (PLC I/O cards)
- ▶ Industrial automation
- ▶ Data acquisition systems

GENERAL DESCRIPTION

The AD5696 and AD5694, members of the *nanoDAC+*[™] family, are low power, quad, 16-/12-bit buffered voltage output DACs. The devices include a gain select pin giving a full-scale output of 2.5 V (gain = 1) or 5 V (gain = 2). The devices operate from a single 2.7 V to 5.5 V supply, are guaranteed monotonic by design, and exhibit less than 0.1% FSR gain error and 1.5 mV offset error performance. The devices are available in a 3 mm \times 3 mm LFCSP package and in a TSSOP package.

The AD5696/AD5694 incorporate a power-on reset circuit and a RSTSEL pin; the RSTSEL pin ensures that the DAC outputs power up to zero scale or midscale and remain at that level until a valid write takes place. The parts contain a per-channel power-down feature that reduces the current consumption of the device in power-down mode to 4 μA at 3 V.

The AD5696/AD5694 use a versatile 2-wire serial interface that operates at clock rates up to 400 kHz and include a V_{LOGIC} pin intended for 1.8 V/3 V/5 V logic.

Table 1. Quad nanoDAC+ Devices

Interface	Reference	16-Bit	14-Bit	12-Bit
SPI	Internal	AD5686R	AD5685R	AD5684R
	External	AD5686		AD5684
I ² C	Internal	AD5696R	AD5695R	AD5694R
	External	AD5696		AD5694

PRODUCT HIGHLIGHTS

1. High Relative Accuracy (INL).
AD5696 (16-bit): ± 2 LSB maximum
AD5694 (12-bit): ± 1 LSB maximum
2. Excellent DC Performance.
Total unadjusted error: $\pm 0.1\%$ of FSR maximum
Offset error: ± 1.5 mV maximum
Gain error: $\pm 0.1\%$ of FSR maximum
3. Two Package Options.
3 mm \times 3 mm, 16-lead LFCSP
16-lead TSSOP

Analog Devices is in the process of updating documentation to provide terminology and language that is culturally appropriate. This is a process with a wide scope and will be phased in as quickly as possible. Thank you for your patience.

TABLE OF CONTENTS

Features.....	1	Write and Update Commands.....	19
Applications.....	1	I ² C Slave Address.....	19
General Description.....	1	Serial Operation.....	19
Product Highlights.....	1	Write Operation.....	19
Functional Block Diagram.....	3	Read Operation.....	20
Specifications.....	4	Multiple DAC Readback Sequence.....	20
AC Characteristics.....	5	Power-Down Operation.....	21
Timing Characteristics.....	6	Load DAC (Hardware $\overline{\text{LDAC}}$ Pin).....	21
Timing Diagram.....	7	$\overline{\text{LDAC}}$ Mask Register.....	22
Absolute Maximum Ratings.....	8	Hardware Reset Pin ($\overline{\text{RESET}}$).....	22
Thermal Resistance.....	8	Reset Select Pin (RSTSEL).....	22
ESD Caution.....	8	Applications Information.....	23
Pin Configurations and Function Descriptions.....	9	Microprocessor Interfacing.....	23
Typical Performance Characteristics.....	10	AD5696/AD5694 to ADSP-BF531 Interface.....	23
Terminology.....	15	Layout Guidelines.....	23
Theory of Operation.....	17	Galvanically Isolated Interface.....	23
Digital-to-Analog Converter.....	17	Outline Dimensions.....	24
Transfer Function.....	17	Ordering Guide.....	24
DAC Architecture.....	17	Resolution and Accuracy (INL) Options.....	24
Serial Interface.....	17	Evaluation Boards.....	24

REVISION HISTORY

3/2024—Rev. C to Rev. D

Changes to Product Highlights Section.....	1
Moved Figure 1.....	3
Changes to Input Low Voltage, V_{IL} Parameter and Input High Voltage, V_{IH} Parameter; Table 2.....	4
Changes to Table 3.....	5
Change to Digital-to-Analog Glitch Impulse Section.....	15
Change to Digital Feedthrough Section.....	15
Change to Digital Crosstalk Section.....	15
Change to Analog Crosstalk Section.....	15
Changes to DAC-to-DAC Crosstalk Section.....	16
Change to Transfer Function Section.....	17
Change to Output Amplifiers Section.....	17
Change to Reset Select Pin (RSTSEL) Section.....	22
Added Resolution and Accuracy (INL) Options.....	24
Changes to Evaluation Boards.....	24

FUNCTIONAL BLOCK DIAGRAM

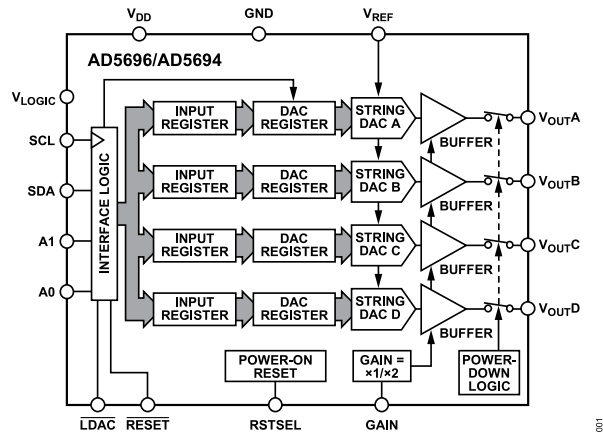

Figure 1.

SPECIFICATIONS

$V_{DD} = 2.7\text{ V to }5.5\text{ V}$; $V_{REF} = 2.5\text{ V}$; $1.62\text{ V} \leq V_{LOGIC} \leq 5.5\text{ V}$; $R_L = 2\text{ k}\Omega$; $C_L = 200\text{ pF}$; all specifications T_{MIN} to T_{MAX} , unless otherwise noted.

Table 2.

Parameter	A Grade			B Grade			Unit	Test Conditions/Comments ¹
	Min	Typ	Max	Min	Typ	Max		
STATIC PERFORMANCE ²								
AD5696								
Resolution	16			16			Bits	
Relative Accuracy		±2	±8		±1	±2	LSB	Gain = 2
		±2	±8		±1	±3	LSB	Gain = 1
Differential Nonlinearity			±1			±1	LSB	Guaranteed monotonic by design
AD5694								
Resolution	12			12			Bits	
Relative Accuracy		±0.12	±2		±0.12	±1	LSB	
Differential Nonlinearity			±1			±1	LSB	Guaranteed monotonic by design
Zero-Code Error		0.4	4		0.4	1.5	mV	All 0s loaded to DAC register
Offset Error		+0.1	±4		+0.1	±1.5	mV	
Full-Scale Error		+0.01	±0.2		+0.01	±0.1	% of FSR	All 1s loaded to DAC register
Gain Error		±0.02	±0.2		±0.02	±0.1	% of FSR	
Total Unadjusted Error		±0.01	±0.25		±0.01	±0.1	% of FSR	Gain = 2
			±0.25			±0.2	% of FSR	Gain = 1
Offset Error Drift ³		±1			±1		μV/°C	
Gain Temperature Coefficient ³		±1			±1		ppm	Of FSR/°C
DC Power Supply Rejection Ratio ³		0.15			0.15		mV/V	DAC code = midscale; $V_{DD} = 5\text{ V} \pm 10\%$
DC Crosstalk ³		±2			±2		μV	Due to single channel, full-scale output change
		±3			±3		μV/mA	Due to load current change
		±2			±2		μV	Due to power-down (per channel)
OUTPUT CHARACTERISTICS ³								
Output Voltage Range	0		V_{REF}	0		V_{REF}	V	Gain = 1
	0		$2 \times V_{REF}$	0		$2 \times V_{REF}$	V	Gain = 2 (see Figure 20)
Capacitive Load Stability		2			2		nF	$R_L = \infty$
		10			10		nF	$R_L = 1\text{ k}\Omega$
Resistive Load ⁴	1			1			kΩ	
Load Regulation								DAC code = midscale
		80			80		μV/mA	$5\text{ V} \pm 10\%$; $-30\text{ mA} \leq I_{OUT} \leq +30\text{ mA}$
		80			80		μV/mA	$3\text{ V} \pm 10\%$; $-20\text{ mA} \leq I_{OUT} \leq +20\text{ mA}$
Short-Circuit Current ⁵		40			40		mA	
Load Impedance at Rails ⁶		25			25		Ω	See Figure 20
Power-Up Time		2.5			2.5		μs	Coming out of power-down mode; $V_{DD} = 5\text{ V}$
REFERENCE INPUT								
Reference Current		90			90		μA	$V_{REF} = V_{DD} = 5.5\text{ V}$, gain = 1
		180			180		μA	$V_{REF} = V_{DD} = 5.5\text{ V}$, gain = 2
Reference Input Range	1		V_{DD}	1		V_{DD}	V	Gain = 1
	1		$V_{DD}/2$	1		$V_{DD}/2$	V	Gain = 2
Reference Input Impedance		16			16		kΩ	Gain = 2
		32			32		kΩ	Gain = 1
LOGIC INPUTS ³								
Input Current			±2			±2	μA	Per pin

SPECIFICATIONS

Table 2. (Continued)

Parameter	A Grade			B Grade			Unit	Test Conditions/Comments ¹
	Min	Typ	Max	Min	Typ	Max		
Input Low Voltage, V_{IL}			$0.3 \times V_{LOGIC}$			$0.3 \times V_{LOGIC}$	V	
Input High Voltage, V_{IH}	$0.7 \times V_{LOGIC}$			$0.7 \times V_{LOGIC}$			V	
Pin Capacitance		2			2		pF	
LOGIC OUTPUTS (SDA) ³								
Output Low Voltage, V_{OL}			0.4			0.4	V	$I_{SINK} = 3 \text{ mA}$
Output High Voltage, V_{OH}	$V_{LOGIC} - 0.4$			$V_{LOGIC} - 0.4$			V	$I_{SOURCE} = 3 \text{ mA}$
Floating State Output Capacitance		4			4		pF	
POWER REQUIREMENTS								
V_{LOGIC}	1.62		5.5	1.62		5.5	V	
I_{LOGIC}			3			3	μA	
V_{DD}	2.7		5.5	2.7		5.5	V	Gain = 1
I_{DD}	$V_{REF} + 1.5$		5.5	$V_{REF} + 1.5$		5.5	V	Gain = 2
								$V_{IH} = V_{DD}$, $V_{IL} = \text{GND}$, $V_{DD} = 2.7 \text{ V to } 5.5 \text{ V}$
Normal Mode ⁷		0.59	0.7		0.59	0.7	mA	
All Power-Down Modes ⁸		1	4		1	4	μA	$-40^\circ\text{C to } +85^\circ\text{C}$
			6			6	μA	$-40^\circ\text{C to } +105^\circ\text{C}$

¹ Temperature range is $-40^\circ\text{C to } +105^\circ\text{C}$.

² DC specifications are tested with the outputs unloaded, unless otherwise noted. Upper dead band (10 mV) exists only when $V_{REF} = V_{DD}$ with gain = 1 or when $V_{REF}/2 = V_{DD}$ with gain = 2. Linearity calculated using a reduced code range of 256 to 65,280 (AD5696) or 12 to 4080 (AD5694).

³ Guaranteed by design and characterization; not production tested.

⁴ Channel A and Channel B can have a combined output current of up to 30 mA. Similarly, Channel C and Channel D can have a combined output current of up to 30 mA up to a junction temperature of 110°C .

⁵ $V_{DD} = 5 \text{ V}$. The device includes current limiting that is intended to protect the device during temporary overload conditions. Junction temperature can be exceeded during current limit. Operation above the specified maximum junction temperature may impair device reliability.

⁶ When drawing a load current at either rail, the output voltage headroom with respect to that rail is limited by the 25Ω typical channel resistance of the output devices. For example, when sinking 1 mA, the minimum output voltage = $25 \Omega \times 1 \text{ mA} = 25 \text{ mV}$ (see Figure 20).

⁷ Interface inactive. All DACs active. DAC outputs unloaded.

⁸ All DACs powered down.

AC CHARACTERISTICS

$V_{DD} = 2.7 \text{ V to } 5.5 \text{ V}$; $V_{REF} = 2.5 \text{ V}$; $1.62 \text{ V} \leq V_{LOGIC} \leq 5.5 \text{ V}$; $R_L = 2 \text{ k}\Omega$; $C_L = 200 \text{ pF}$; all specifications T_{MIN} to T_{MAX} , unless otherwise noted.

Table 3.

Parameter ^{1, 2}	Min	Typ	Max	Unit	Test Conditions/Comments ³
Output Voltage Settling Time					$\frac{1}{4}$ to $\frac{3}{4}$ scale settling to $\pm 2 \text{ LSB}$
AD5696		5	8	μs	
AD5694		5	7	μs	
Slew Rate		0.8		V/ μs	
Digital-to-Analog Glitch Impulse		0.5		nV \times sec	1 LSB change around major carry transition
Digital Feedthrough		0.13		nV \times sec	
Multiplying Bandwidth		500		kHz	
Digital Crosstalk		0.1		nV \times sec	
Analog Crosstalk		0.2		nV \times sec	
DAC-to-DAC Crosstalk		0.3		nV \times sec	
Total Harmonic Distortion ⁴		-80		dB	At T_A , BW = 20 kHz, $V_{DD} = 5 \text{ V}$, $f_{OUT} = 1 \text{ kHz}$

SPECIFICATIONS

Table 3. (Continued)

Parameter ^{1, 2}	Min	Typ	Max	Unit	Test Conditions/Comments ³
Output Noise Spectral Density		100		nV/ $\sqrt{\text{Hz}}$	DAC code = midscale, 10 kHz, gain = 2
Output Noise		6		μV p-p	0.1 Hz to 10 Hz
Signal-to-Noise Ratio (SNR)		90		dB	At T_A , BW = 20 kHz, $V_{DD} = 5\text{ V}$, $f_{OUT} = 1\text{ kHz}$
Spurious-Free Dynamic Range (SFDR)		83		dB	At T_A , BW = 20 kHz, $V_{DD} = 5\text{ V}$, $f_{OUT} = 1\text{ kHz}$
Signal-to-Noise-and-Distortion Ratio (SINAD)		80		dB	At T_A , BW = 20 kHz, $V_{DD} = 5\text{ V}$, $f_{OUT} = 1\text{ kHz}$

¹ Guaranteed by design and characterization; not production tested.

² See the Terminology section.

³ Temperature range is -40°C to $+105^\circ\text{C}$; typical at 25°C .

⁴ Digitally generated sine wave at 1 kHz.

TIMING CHARACTERISTICS

$V_{DD} = 2.7\text{ V}$ to 5.5 V ; $1.62\text{ V} \leq V_{LOGIC} \leq 5.5\text{ V}$; all specifications T_{MIN} to T_{MAX} , unless otherwise noted.

Table 4.

Parameter ^{1, 2}	Min	Max	Unit	Description
t_1	2.5		μs	SCL cycle time
t_2	0.6		μs	t_{HIGH} , SCL high time
t_3	1.3		μs	t_{LOW} , SCL low time
t_4	0.6		μs	$t_{HD,STA}$, start/repeated start hold time
t_5	100		ns	$t_{SU,DAT}$, data setup time
t_6^3	0	0.9	μs	$t_{HD,DAT}$, data hold time
t_7	0.6		μs	$t_{SU,STA}$, repeated start setup time
t_8	0.6		μs	$t_{SU,STO}$, stop condition setup time
t_9	1.3		μs	t_{BUF} , bus free time between a stop condition and a start condition
t_{10}^4	0	300	ns	t_R , rise time of SCL and SDA when receiving
$t_{11}^{4,5}$	$20 + 0.1C_B$	300	ns	t_F , fall time of SCL and SDA when transmitting/receiving
t_{12}	20		ns	\overline{LDAC} pulse width
t_{13}	400		ns	SCL rising edge to \overline{LDAC} rising edge
t_{SP}^6	0	50	ns	Pulse width of suppressed spike
C_B^5		400	pF	Capacitive load for each bus line

¹ See Figure 2.

² Guaranteed by design and characterization; not production tested.

³ A master device must provide a hold time of at least 300 ns for the SDA signal (referred to the V_{IH} min of the SCL signal) to bridge the undefined region of the SCL falling edge.

⁴ t_R and t_F are measured from $0.3 \times V_{DD}$ to $0.7 \times V_{DD}$.

⁵ C_B is the total capacitance of one bus line in pF.

⁶ Input filtering on the SCL and SDA inputs suppresses noise spikes that are less than 50 ns.

SPECIFICATIONS

TIMING DIAGRAM

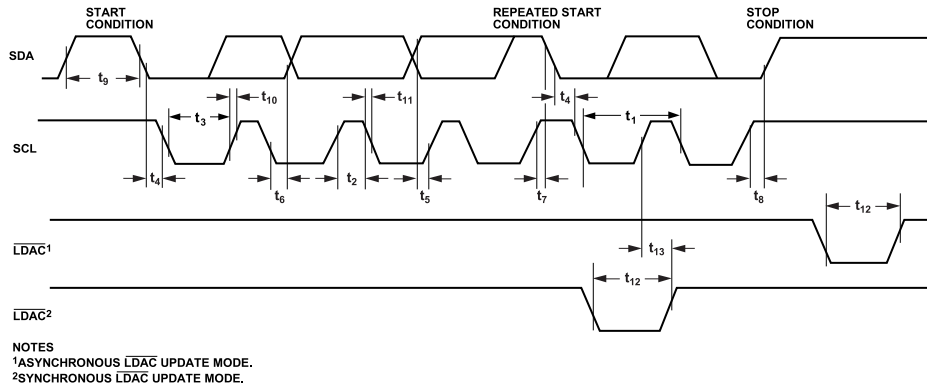

Figure 2. 2-Wire Serial Interface Timing Diagram

ABSOLUTE MAXIMUM RATINGS

$T_A = 25^\circ\text{C}$, unless otherwise noted.

Table 5.

Parameter	Rating
V_{DD} to GND	-0.3 V to +7 V
V_{LOGIC} to GND	-0.3 V to +7 V
V_{OUT} to GND	-0.3 V to $V_{DD} + 0.3$ V
V_{REF} to GND	-0.3 V to $V_{DD} + 0.3$ V
Digital Input Voltage to GND ¹	-0.3 V to $V_{LOGIC} + 0.3$ V
SDA and SCL to GND	-0.3 V to +7 V
Operating Temperature Range	-40°C to +105°C
Storage Temperature Range	-65°C to +150°C
Junction Temperature	125°C
Reflow Soldering Peak Temperature, Pb Free (J-STD-020)	260°C

¹ Excluding SDA and SCL.

Stresses at or above those listed under Absolute Maximum Ratings may cause permanent damage to the product. This is a stress rating only; functional operation of the product at these or any other conditions above those indicated in the operational section of this specification is not implied. Operation beyond the maximum operating conditions for extended periods may affect product reliability.

THERMAL RESISTANCE

θ_{JA} is specified for the worst-case conditions, that is, a device soldered in a circuit board for surface-mount packages. This value was measured using a JEDEC standard 4-layer board with zero airflow. For the LFCSP package, the exposed pad must be tied to GND.

Table 6. Thermal Resistance

Package Type	θ_{JA}	Unit
16-Lead LFCSP	70	°C/W
16-Lead TSSOP	112.6	°C/W

ESD CAUTION

ESD (electrostatic discharge) sensitive device. Charged devices and circuit boards can discharge without detection. Although this product features patented or proprietary protection circuitry, damage may occur on devices subjected to high energy ESD. Therefore, proper ESD precautions should be taken to avoid performance degradation or loss of functionality.

PIN CONFIGURATIONS AND FUNCTION DESCRIPTIONS

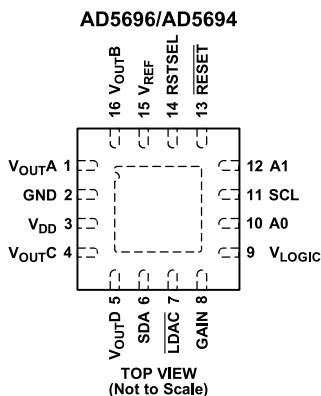

NOTES
1. THE EXPOSED PAD MUST BE TIED TO GND. 006

Figure 3. Pin Configuration, 16-Lead LFCSP

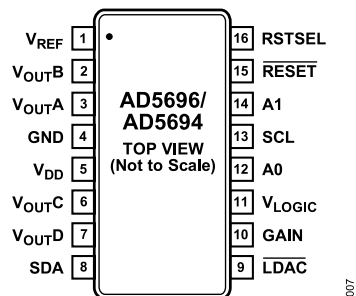

Figure 4. Pin Configuration, 16-Lead TSSOP

Table 7. Pin Function Descriptions

Pin No.			
LFCSP	TSSOP	Mnemonic	Description
1	3	V _{OUTA}	Analog Output Voltage from DAC A. The output amplifier has rail-to-rail operation.
2	4	GND	Ground Reference Point for All Circuitry on the Part.
3	5	V _{DD}	Power Supply Input. The parts can be operated from 2.7 V to 5.5 V. The supply should be decoupled with a 10 μF capacitor in parallel with a 0.1 μF capacitor to GND.
4	6	V _{OUTC}	Analog Output Voltage from DAC C. The output amplifier has rail-to-rail operation.
5	7	V _{OUTD}	Analog Output Voltage from DAC D. The output amplifier has rail-to-rail operation.
6	8	SDA	Serial Data Input. This pin is used in conjunction with the SCL line to clock data into or out of the 24-bit input shift register. SDA is a bidirectional, open-drain data line that should be pulled to the supply with an external pull-up resistor.
7	9	LDAC	LDAC can be operated in two modes, asynchronous update mode and synchronous update mode. Pulsing this pin low allows any or all DAC registers to be updated if the input registers have new data; all DAC outputs are simultaneously updated. This pin can also be tied permanently low.
8	10	GAIN	Gain Select Pin. When this pin is tied to GND, all four DAC outputs have a span of 0 V to V _{REF} . When this pin is tied to V _{LOGIC} , all four DAC outputs have a span of 0 V to 2 × V _{REF} .
9	11	V _{LOGIC}	Digital Power Supply. Voltage ranges from 1.62 V to 5.5 V.
10	12	A0	Address Input. Sets the first LSB of the 7-bit slave address.
11	13	SCL	Serial Clock Line. This pin is used in conjunction with the SDA line to clock data into or out of the 24-bit input shift register.
12	14	A1	Address Input. Sets the second LSB of the 7-bit slave address.
13	15	RESET	Asynchronous Reset Input. The RESET input is falling edge sensitive. When RESET is activated (low), the input register and the DAC register are updated with zero scale or midscale, depending on the state of the RSTSEL pin. When RESET is low, all LDAC pulses are ignored. If the pin is forced low at power-up, the POR circuit does not initialize correctly until the pin is released.
14	16	RSTSEL	Power-On Reset Pin. When this pin is tied to GND, all four DACs are powered up to zero scale. When this pin is tied to V _{LOGIC} , all four DACs are powered up to midscale.
15	1	V _{REF}	Reference Input Voltage.
16	2	V _{OUTB}	Analog Output Voltage from DAC B. The output amplifier has rail-to-rail operation.
17	N/A	EPAD	Exposed Pad. The exposed pad must be tied to GND.

TYPICAL PERFORMANCE CHARACTERISTICS

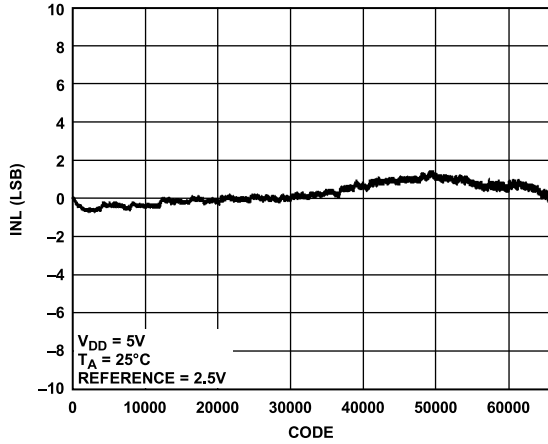

Figure 5. AD5696 INL

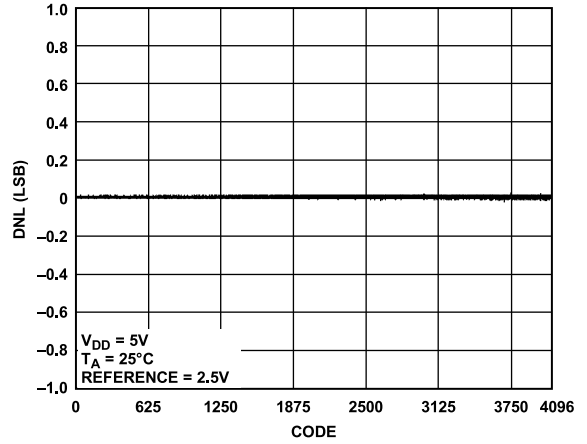

Figure 8. AD5694 DNL

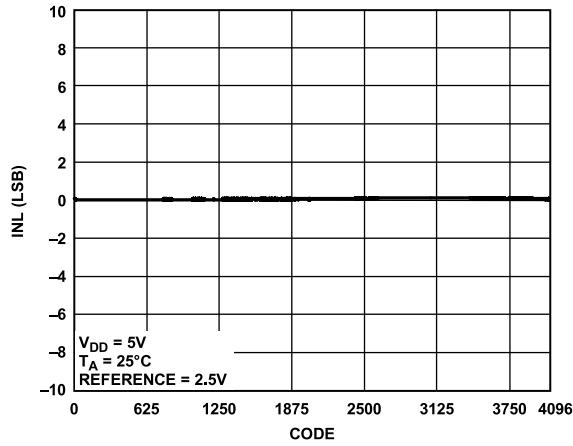

Figure 6. AD5694 INL

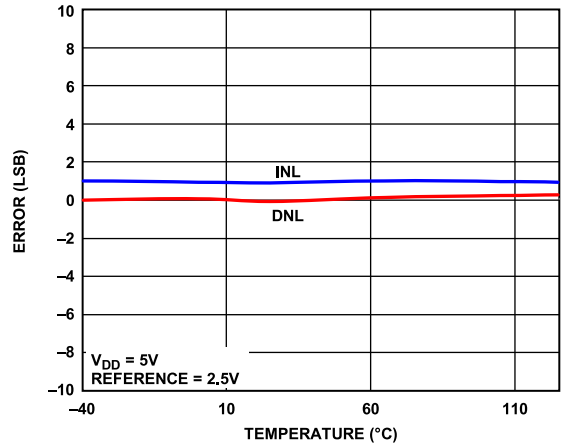

Figure 9. INL Error and DNL Error vs. Temperature

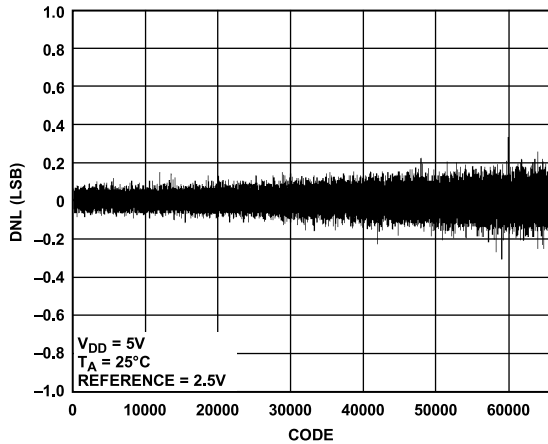

Figure 7. AD5696 DNL

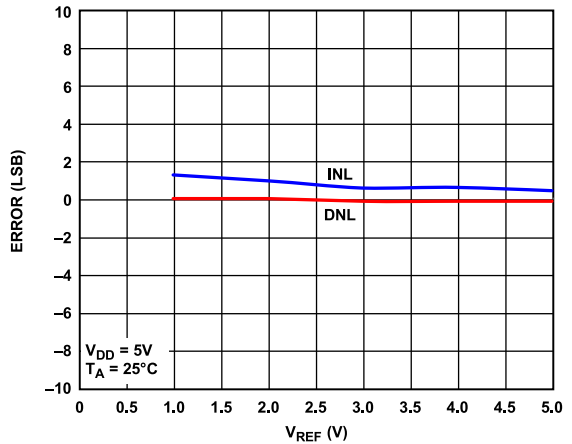

Figure 10. INL Error and DNL Error vs. V_{REF}

TYPICAL PERFORMANCE CHARACTERISTICS

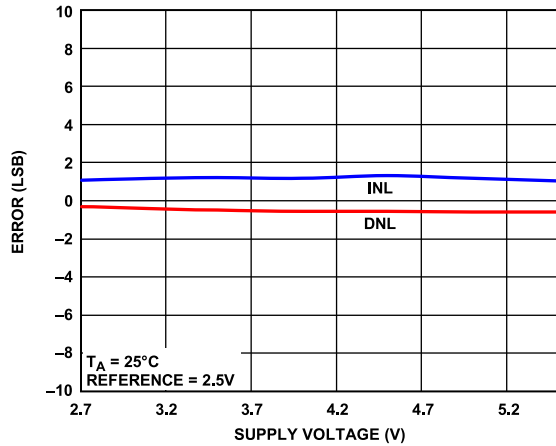

Figure 11. INL Error and DNL Error vs. Supply Voltage

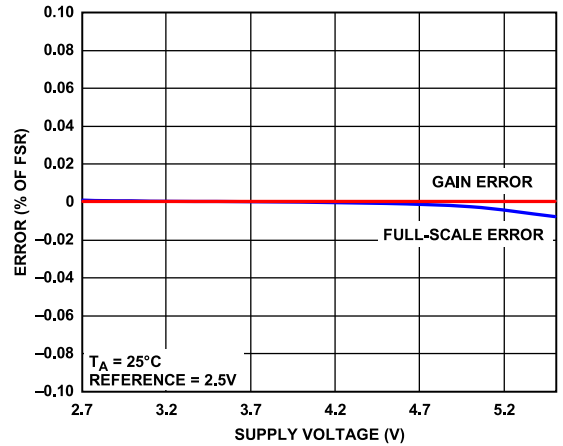

Figure 14. Gain Error and Full-Scale Error vs. Supply Voltage

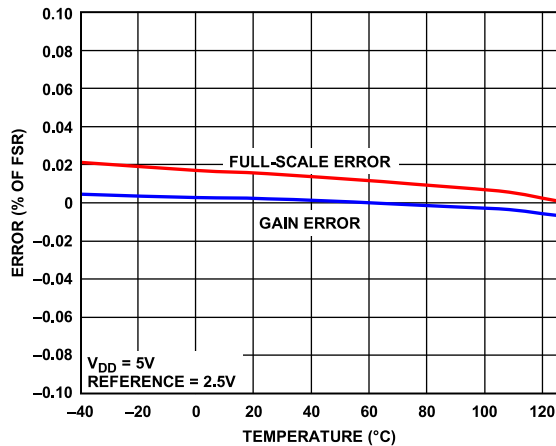

Figure 12. Gain Error and Full-Scale Error vs. Temperature

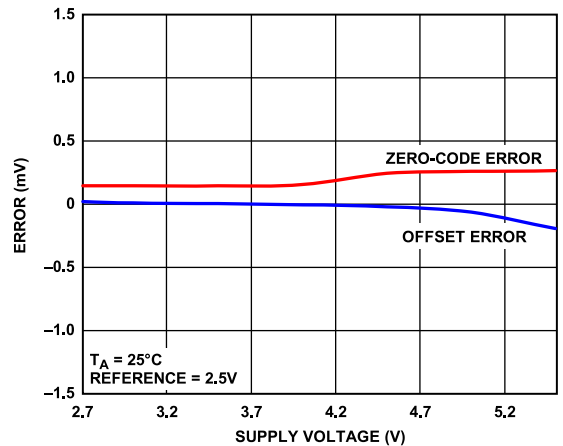

Figure 15. Zero-Code Error and Offset Error vs. Supply Voltage

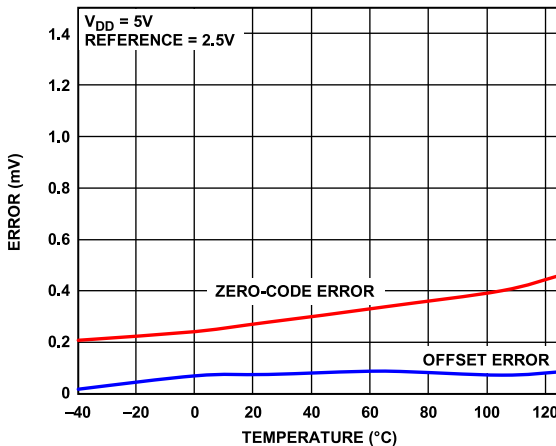

Figure 13. Zero-Code Error and Offset Error vs. Temperature

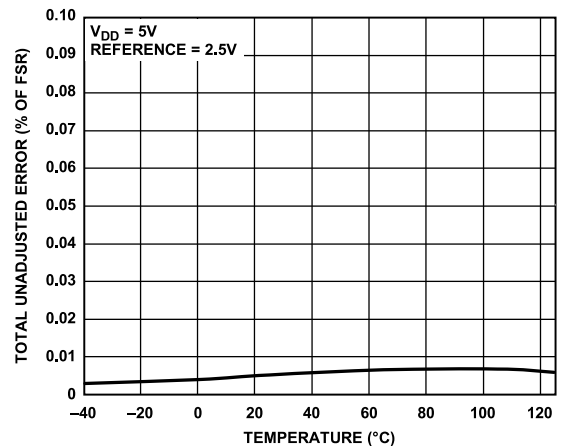

Figure 16. TUE vs. Temperature

TYPICAL PERFORMANCE CHARACTERISTICS

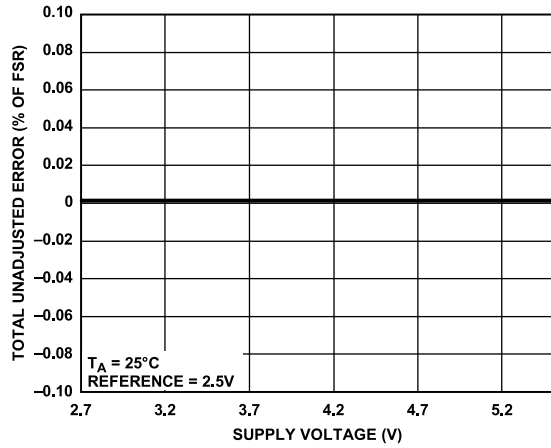

Figure 17. TUE vs. Supply Voltage, Gain = 1

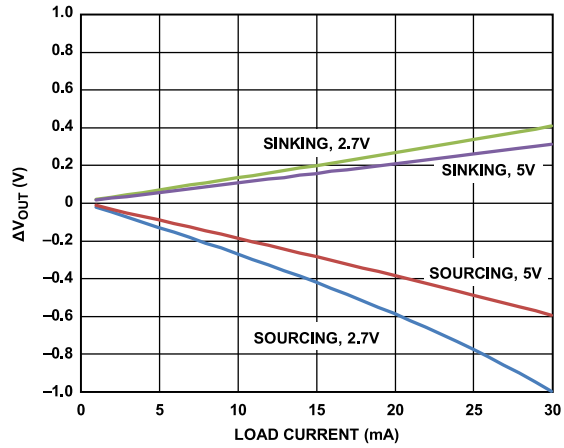

Figure 20. Headroom/Footroom vs. Load Current

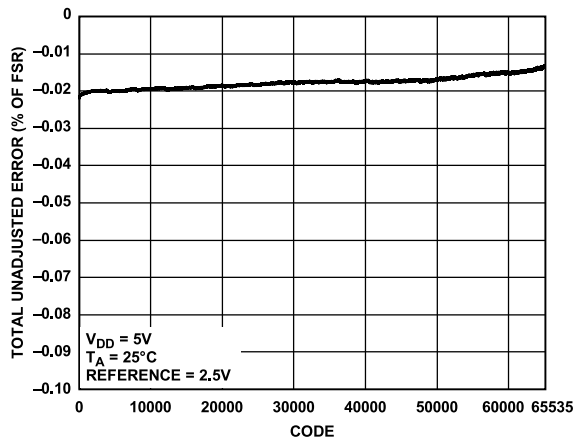

Figure 18. TUE vs. Code, AD5696

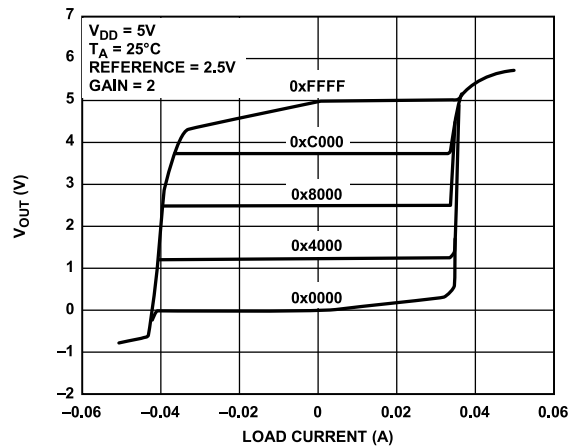

Figure 21. Source and Sink Capability at 5 V

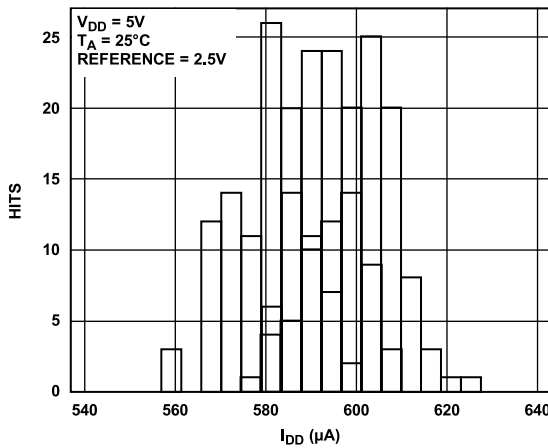

Figure 19. I_{DD} Histogram at 5 V

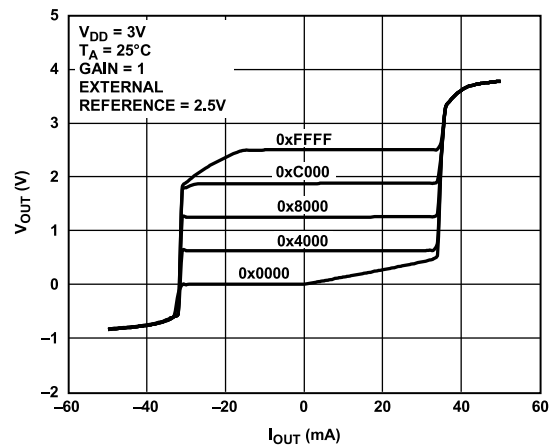

Figure 22. Source and Sink Capability at 3 V

TYPICAL PERFORMANCE CHARACTERISTICS

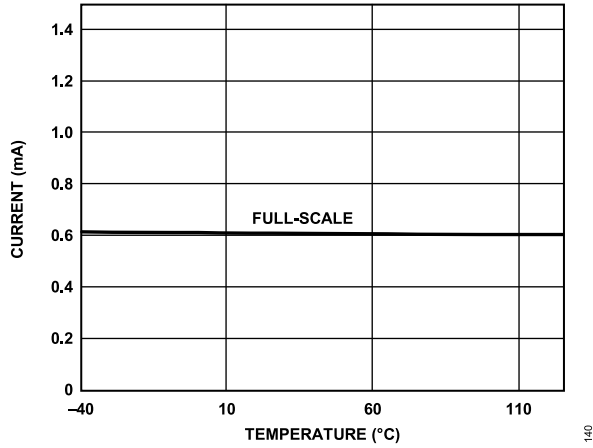

Figure 23. Supply Current vs. Temperature

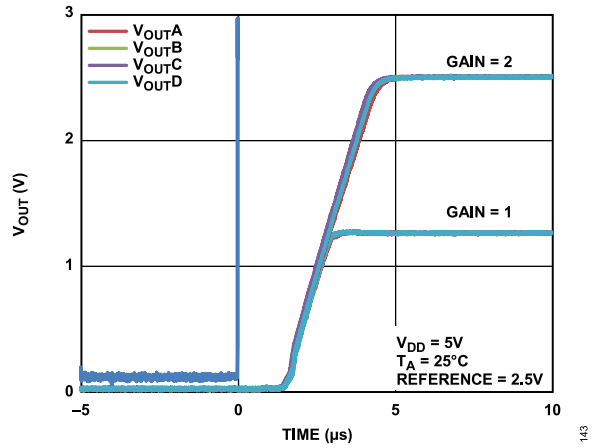

Figure 26. Exiting Power-Down to Midscale

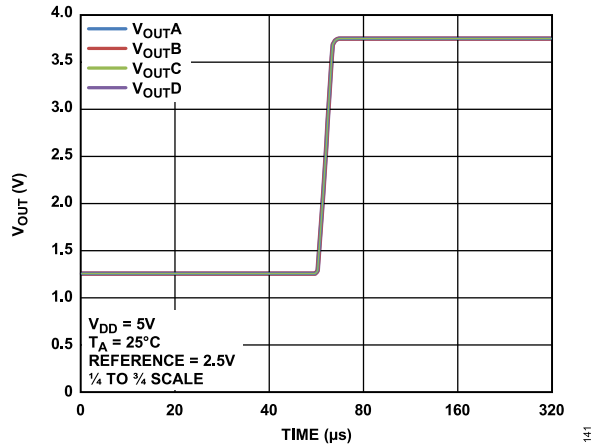

Figure 24. Settling Time

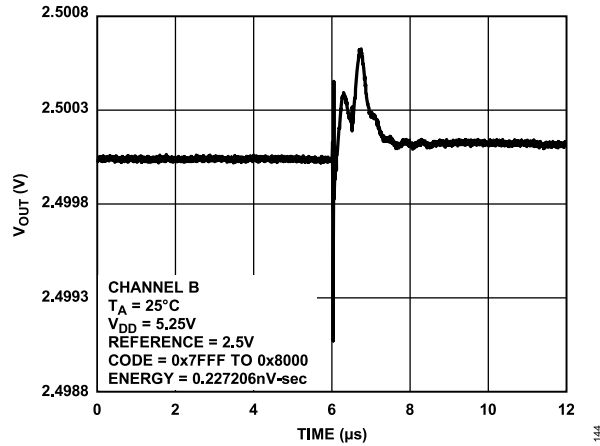

Figure 27. Digital-to-Analog Glitch Impulse

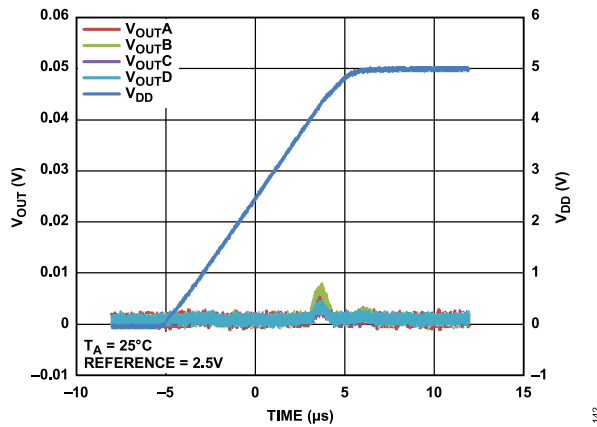

Figure 25. Power-On Reset to 0 V

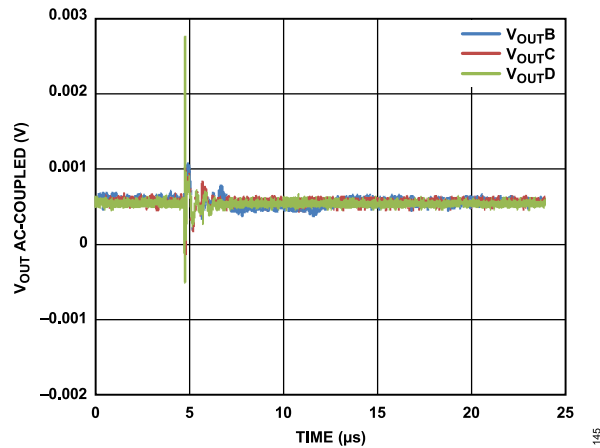

Figure 28. Analog Crosstalk, V_{OUTA}

TYPICAL PERFORMANCE CHARACTERISTICS

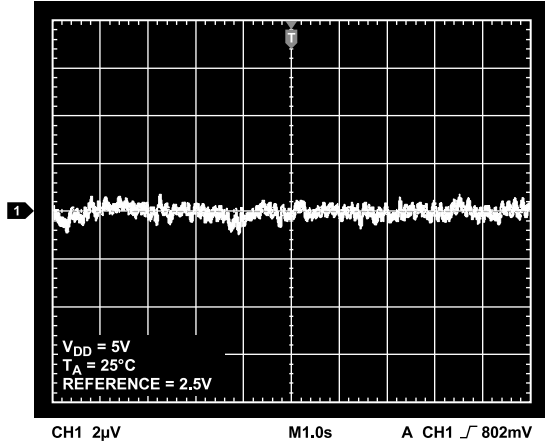

Figure 29. 0.1 Hz to 10 Hz Output Noise Plot

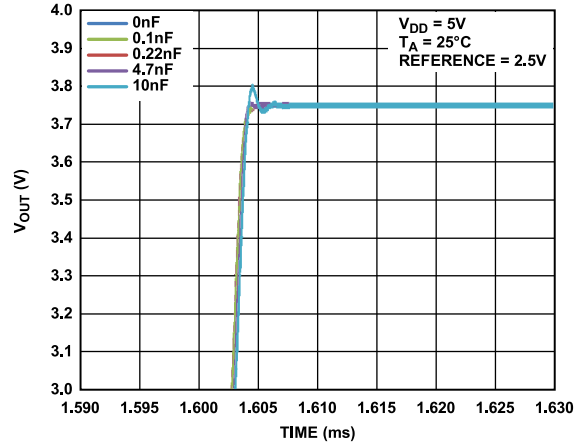

Figure 31. Settling Time vs. Capacitive Load

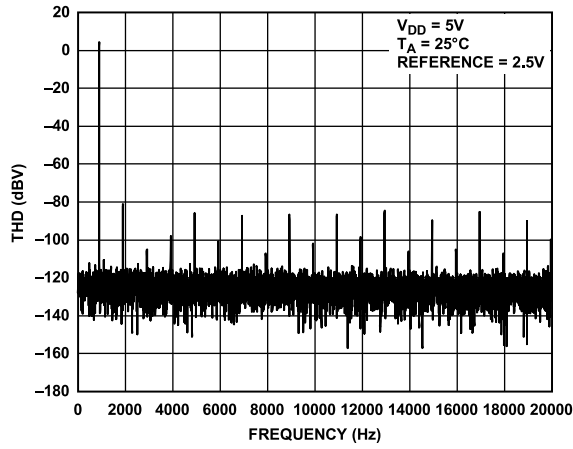

Figure 30. Total Harmonic Distortion at 1 kHz

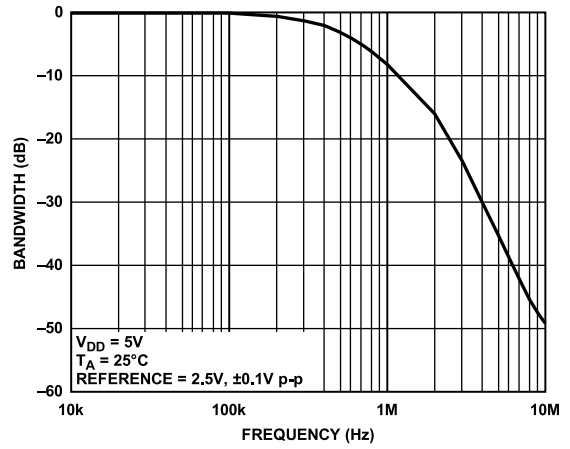

Figure 32. Multiplying Bandwidth

TERMINOLOGY

Relative Accuracy or Integral Nonlinearity (INL)

Relative accuracy or integral nonlinearity is a measurement of the maximum deviation, in LSBs, from a straight line passing through the endpoints of the DAC transfer function. [Figure 5](#) and [Figure 6](#) show typical INL vs. code plots.

Differential Nonlinearity (DNL)

Differential nonlinearity is the difference between the measured change and the ideal 1 LSB change between any two adjacent codes. A specified differential nonlinearity of ± 1 LSB maximum ensures monotonicity. The AD5696/AD5694 are guaranteed monotonic by design. [Figure 7](#) and [Figure 8](#) show typical DNL vs. code plots.

Zero-Code Error

Zero-code error is a measurement of the output error when zero code (0x0000) is loaded to the DAC register. Ideally, the output should be 0 V. The zero-code error is always positive in the AD5696/AD5694 because the output of the DAC cannot go below 0 V due to a combination of the offset errors in the DAC and the output amplifier. Zero-code error is expressed in mV. [Figure 13](#) shows a plot of zero-code error vs. temperature.

Full-Scale Error

Full-scale error is a measurement of the output error when full-scale code (0xFFFF) is loaded to the DAC register. Ideally, the output should be $V_{DD} - 1$ LSB. Full-scale error is expressed as a percentage of the full-scale range (% of FSR). [Figure 12](#) shows a plot of full-scale error vs. temperature.

Gain Error

Gain error is a measurement of the span error of the DAC. It is the deviation in slope of the DAC transfer characteristic from the ideal expressed in % of FSR.

Gain Temperature Coefficient

Gain temperature coefficient is a measurement of the change in gain error with changes in temperature. It is expressed in ppm of FSR/ $^{\circ}$ C.

Offset Error

Offset error is a measurement of the difference between V_{OUT} (actual) and V_{OUT} (ideal) expressed in mV in the linear region of the transfer function. It can be negative or positive.

Offset Error Drift

Offset error drift is a measurement of the change in offset error with changes in temperature. It is expressed in μ V/ $^{\circ}$ C.

DC Power Supply Rejection Ratio (PSRR)

DC PSRR indicates how the output of the DAC is affected by changes in the supply voltage. PSRR is the ratio of the change

in V_{OUT} to a change in V_{DD} for midscale output of the DAC. It is measured in mV/V. V_{REF} is held at 2.5 V, and V_{DD} is varied by $\pm 10\%$.

Output Voltage Settling Time

The output voltage settling time is the amount of time it takes for the output of a DAC to settle to a specified level for a $\frac{1}{4}$ to $\frac{3}{4}$ full-scale input change.

Digital-to-Analog Glitch Impulse

Digital-to-analog glitch impulse is the impulse injected into the analog output when the input code in the DAC register changes state. It is normally specified as the area of the glitch in nV \times sec and is measured when the digital input code is changed by 1 LSB at the major carry transition (0x7FFF to 0x8000) (see [Figure 27](#)).

Digital Feedthrough

Digital feedthrough is a measurement of the impulse injected into the analog output of the DAC from the digital inputs of the DAC, but is measured when the DAC output is not updated. It is specified in nV \times sec and measured with a full-scale code change on the data bus, that is, from all 0s to all 1s and vice versa.

Noise Spectral Density (NSD)

Noise spectral density is a measurement of the internally generated random noise. Random noise is characterized as a spectral density (nV/ \sqrt Hz) and is measured by loading the DAC to mid-scale and measuring noise at the output. It is measured in nV/ \sqrt Hz.

DC Crosstalk

DC crosstalk is the dc change in the output level of one DAC in response to a change in the output of another DAC. It is measured with a full-scale output change on one DAC (or soft power-down and power-up) while monitoring another DAC kept at midscale. It is expressed in μ V.

DC crosstalk due to load current change is a measurement of the impact that a change in load current on one DAC has on another DAC kept at midscale. It is expressed in μ V/mA.

Digital Crosstalk

Digital crosstalk is the glitch impulse transferred to the output of one DAC at midscale in response to a full-scale code change (all 0s to all 1s and vice versa) in the input register of another DAC. It is expressed in nV \times sec.

Analog Crosstalk

Analog crosstalk is the glitch impulse transferred to the output of one DAC in response to a change in the output of another DAC. To measure analog crosstalk, load one of the input registers with a full-scale code change (all 0s to all 1s and vice versa), and then execute a software LDAC and monitor the output of the DAC whose

TERMINOLOGY

digital code was not changed. The area of the glitch is expressed in $nV \times \text{sec}$.

DAC-to-DAC Crosstalk

DAC-to-DAC crosstalk is the glitch impulse transferred to the output of one DAC in response to a digital code change and subsequent analog output change of another DAC. It is measured by loading one channel with a full-scale code change (all 0s to all 1s and vice versa) using the write to and update commands while monitoring the output of another channel that is at mid-scale. The area of the glitch is expressed in $nV \times \text{sec}$.

Multiplying Bandwidth

The amplifiers within the DAC have a finite bandwidth. The multiplying bandwidth is a measure of this. A sine wave on the reference (with full-scale code loaded to the DAC) appears on the output. The multiplying bandwidth is the frequency at which the output amplitude falls to 3 dB below the input.

Total Harmonic Distortion (THD)

THD is the difference between an ideal sine wave and its attenuated version using the DAC. The sine wave is used as the reference for the DAC; THD is a measurement of the harmonics present on the DAC output. It is measured in dB.

THEORY OF OPERATION

DIGITAL-TO-ANALOG CONVERTER

The AD5696/AD5694 are quad, 16-/12-bit, serial input, voltage output DACs that operate from supply voltages of 2.7 V to 5.5 V. Data is written to the AD5696/AD5694 in a 24-bit word format via a 2-wire serial interface. The AD5696/AD5694 incorporate a power-on reset circuit to ensure that the DAC output powers up to a known output state. The devices also have a software power-down mode that reduces the current consumption to 4 μ A.

TRANSFER FUNCTION

Because the input coding to the DAC is straight binary, the ideal output voltage is given by

$$V_{OUT} = V_{REF} \times Gain \times \left[\frac{D}{2^N} \right] \quad (1)$$

where:

V_{REF} is the value of the external reference.

Gain is the gain of the output amplifier and is set to 1 by default.

The gain can be set to 1 or 2 using the gain select pin. When the GAIN pin is tied to GND, all four DAC outputs have a span of 0 V to V_{REF} . When this pin is tied to V_{LOGIC} , all four DAC outputs have a span of 0 V to $2 \times V_{REF}$.

D is the decimal equivalent of the binary code that is loaded to the DAC register as follows: 0 to 4095 for the 12-bit AD5694, and 0 to 65,535 for the 16-bit AD5696.

N is the DAC resolution (12 bits or 16 bits).

DAC ARCHITECTURE

The DAC architecture consists of a string DAC followed by an output amplifier. Figure 33 shows a block diagram of the DAC architecture.

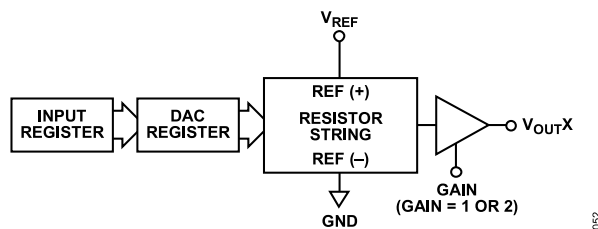

Figure 33. Single DAC Channel Architecture Block Diagram

The resistor string structure is shown in Figure 34. Each resistor in the string has a value *R*. The code loaded to the DAC register determines the node on the string from which the voltage is tapped off and fed into the output amplifier. The voltage is tapped off by closing one of the switches that connect the string to the amplifier. Because the AD5696/AD5694 are a string of resistors, they are guaranteed monotonic.

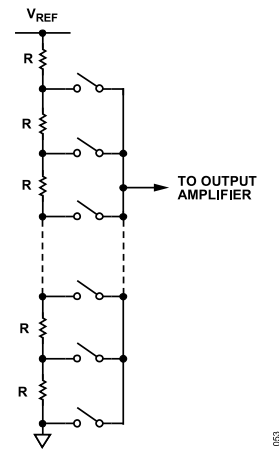

Figure 34. Resistor String Structure

Output Amplifiers

The output buffer amplifier can generate rail-to-rail voltages on its output for an output range of 0 V to V_{DD} . The actual range depends on the value of V_{REF} , the GAIN pin, the offset error, and the gain error. The GAIN pin selects the gain of the output.

- ▶ When this pin is tied to GND, all four outputs have a gain of 1, and the output range is from 0 V to V_{REF} .
- ▶ When this pin is tied to V_{LOGIC} , all four outputs have a gain of 2, and the output range is from 0 V to $2 \times V_{REF}$.

The output amplifiers are capable of driving a load of 1 k Ω in parallel with 2 nF to GND. The slew rate is 0.8 V/ μ s with a 1/4 to 3/4 scale settling time of 5 μ s.

SERIAL INTERFACE

The AD5696/AD5694 have a 2-wire, I^2C -compatible serial interface (see the *I²C-Bus Specification*, Version 2.1, January 2000, available from Philips Semiconductor). See Figure 2 for a timing diagram of a typical write sequence. The AD5696/AD5694 can be connected to an I^2C bus as slave devices, under the control of a master device. The AD5696/AD5694 support standard (100 kHz) and fast (400 kHz) data transfer modes. Support is not provided for 10-bit addressing or general call addressing.

Input Shift Register

The input shift register of the AD5696/AD5694 is 24 bits wide. Data is loaded into the device, MSB first, as a 24-bit word under the control of the serial clock input, SCL. The first eight MSBs make up the command byte (see Figure 35 and Figure 36).

- ▶ The first four bits of the command byte are the command bits (C3, C2, C1, and C0), which control the mode of operation of the device (see Table 8).
- ▶ The last four bits of the command byte are the address bits (DAC D, DAC C, DAC B, and DAC A), which select the DAC that is operated on by the command (see Table 9).

THEORY OF OPERATION

The 8-bit command byte is followed by two data bytes, which contain the data-word. For the AD5696, the data-word comprises the 16-bit input code (see Figure 35); for the AD5694, the data-word comprises the 12-bit input code followed by four don't care bits (see Figure 36). The data bits are transferred to the input shift register on the 24 falling edges of SCL.

Commands can be executed on one DAC channel, any two or three DAC channels, or on all four DAC channels, depending on the address bits selected (see Table 9).

Table 8. Command Definitions

Command Bits				
C3	C2	C1	C0	Command
0	0	0	0	No operation
0	0	0	1	Write to Input Register n (dependent on LDAC)
0	0	1	0	Update DAC Register n with contents of Input Register n
0	0	1	1	Write to and update DAC Channel n
0	1	0	0	Power down/power up DAC
0	1	0	1	Hardware LDAC mask register
0	1	1	0	Software reset (power-on reset)
0	1	1	1	Reserved

Table 8. Command Definitions (Continued)

Command Bits				
C3	C2	C1	C0	Command
1	X ¹	X ¹	X ¹	Reserved

¹ X = don't care.

Table 9. Address Bits and Selected DACs

Address Bits				
DAC D	DAC C	DAC B	DAC A	Selected DAC Channels ¹
0	0	0	1	DAC A
0	0	1	0	DAC B
0	0	1	1	DAC A and DAC B
0	1	0	0	DAC C
0	1	0	1	DAC A and DAC C
0	1	1	0	DAC B and DAC C
0	1	1	1	DAC A, DAC B, and DAC C
1	0	0	0	DAC D
1	0	0	1	DAC A and DAC D
...
1	1	1	1	All DACs

¹ Any combination of DAC channels can be selected using the address bits.

DB23	DB22	DB21	DB20	DB19	DB18	DB17	DB16	DB15	DB14	DB13	DB12	DB11	DB10	DB9	DB8	DB7	DB6	DB5	DB4	DB3	DB2	DB1	DB0
C3	C2	C1	C0	DAC D	DAC C	DAC B	DAC A	D15	D14	D13	D12	D11	D10	D9	D8	D7	D6	D5	D4	D3	D2	D1	D0
COMMAND				DAC ADDRESS				DAC DATA								DAC DATA							
COMMAND BYTE								DATA HIGH BYTE								DATA LOW BYTE							

Figure 35. Input Shift Register Contents, AD5696

DB23	DB22	DB21	DB20	DB19	DB18	DB17	DB16	DB15	DB14	DB13	DB12	DB11	DB10	DB9	DB8	DB7	DB6	DB5	DB4	DB3	DB2	DB1	DB0
C3	C2	C1	C0	DAC D	DAC C	DAC B	DAC A	D11	D10	D9	D8	D7	D6	D5	D4	D3	D2	D1	D0	X	X	X	X
COMMAND				DAC ADDRESS				DAC DATA								DAC DATA							
COMMAND BYTE								DATA HIGH BYTE								DATA LOW BYTE							

Figure 36. Input Shift Register Contents, AD5694

THEORY OF OPERATION

WRITE AND UPDATE COMMANDS

For more information about the $\overline{\text{LDAC}}$ function, see the [Load DAC \(Hardware LDAC Pin\)](#) section.

Write to Input Register N (Dependent on $\overline{\text{LDAC}}$)

Command 0001 allows the user to write to each DAC’s dedicated input register individually. When $\overline{\text{LDAC}}$ is low, the input register is transparent (if not controlled by the $\overline{\text{LDAC}}$ mask register).

Update DAC Register N With Contents of Input Register N

Command 0010 loads the DAC registers/outputs with the contents of the input registers selected by the address bits (see [Table 9](#)) and updates the DAC outputs directly.

Write to and Update DAC Channel N (Independent of $\overline{\text{LDAC}}$)

Command 0011 allows the user to write to the DAC registers and update the DAC outputs directly, independent of the state of the $\overline{\text{LDAC}}$ pin.

I²C SLAVE ADDRESS

The AD5696/AD5694 have a 7-bit I²C slave address. The five MSBs are 00011, and the two LSBs (A1 and A0) are set by the state of the A1 and A0 address pins. The ability to make hard-wired changes to A1 and A0 allows the user to incorporate up to four AD5696/AD5694 devices on one bus (see [Table 10](#)).

Table 10. Device Address Selection

A1 Pin Connection	A0 Pin Connection	A1 Bit	A0 Bit
GND	GND	0	0
GND	V _{LOGIC}	0	1
V _{LOGIC}	GND	1	0
V _{LOGIC}	V _{LOGIC}	1	1

SERIAL OPERATION

The 2-wire I²C serial bus protocol operates as follows:

1. The master initiates a data transfer by establishing a start condition when a high-to-low transition on the SDA line occurs while SCL is high. The following byte is the address byte, which consists of the 7-bit slave address.
2. The slave device with the transmitted address responds by pulling SDA low during the 9th clock pulse (this is called the acknowledge bit). At this stage, all other devices on the bus remain idle while the selected device waits for data to be written to, or read from, its input shift register.
3. Data is transmitted over the serial bus in sequences of nine clock pulses (eight data bits followed by an acknowledge bit). Transitions on the SDA line must occur during the low period of SCL; SDA must remain stable during the high period of SCL.
4. After all data bits are read or written, a stop condition is established. In write mode, the master pulls the SDA line high during the 10th clock pulse to establish a stop condition. In read mode, the master issues a no acknowledge for the 9th clock pulse (that is, the SDA line remains high). The master then brings the SDA line low before the 10th clock pulse and then high again during the 10th clock pulse to establish a stop condition.

WRITE OPERATION

When writing to the AD5696/AD5694, the user must begin with a start command followed by an address byte (R/W = 0), after which the DAC acknowledges that it is prepared to receive data by pulling SDA low. The AD5696/AD5694 require two bytes of data for the DAC and a command byte that controls various DAC functions. Three bytes of data must, therefore, be written to the DAC with the command byte followed by the most significant data byte and the least significant data byte, as shown in [Figure 37](#). All these data bytes are acknowledged by the AD5696/AD5694. A stop condition follows.

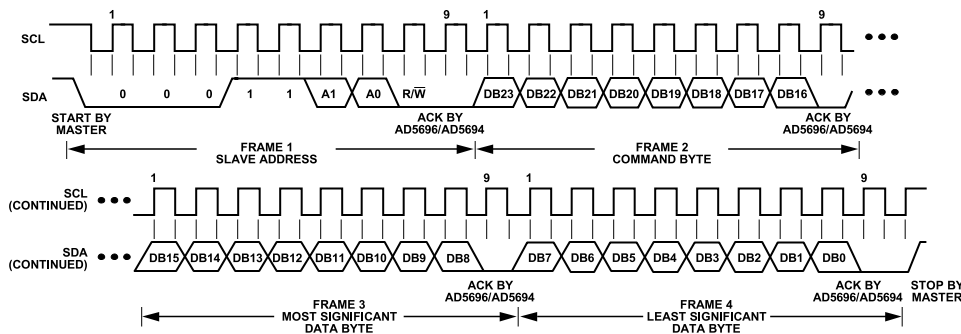

Figure 37. I²C Write Operation

THEORY OF OPERATION

READ OPERATION

When reading data back from the AD5696/AD5694, the user must begin with a start command followed by an address byte ($R/\bar{W} = 0$), after which the DAC acknowledges that it is prepared to receive data by pulling SDA low. The address byte must be followed by the command byte, which determines both the read command that is to follow and the pointer address to read from; the command byte is also acknowledged by the DAC. The user configures the channel to read back the contents of one or more DAC registers and sets the readback command to active using the command byte.

Following this, the master establishes a repeated start condition, and the address is resent with $R/\bar{W} = 1$. This byte is acknowledged by the DAC, indicating that it is prepared to transmit data. Two bytes of data are then read from the DAC, as shown in Figure 38. A NACK condition from the master, followed by a stop condition, completes the read sequence. If more than one DAC is selected, Channel A is read back by default.

acknowledges that it is prepared to receive data by pulling SDA low. The address byte must be followed by the command byte, which is also acknowledged by the DAC. The user selects the first channel to read back using the command byte.

Following this, the master establishes a repeated start condition, and the address is resent with $R/\bar{W} = 1$. This byte is acknowledged by the DAC, indicating that it is prepared to transmit data. The first two bytes of data are then read from DAC Input Register n (selected using the command byte), most significant byte first, as shown in Figure 38. The next two bytes read back are the contents of DAC Input Register $n + 1$, and the next bytes read back are the contents of DAC Input Register $n + 2$. Data is read from the DAC input registers in this auto-incremented fashion until a NACK followed by a stop condition follows. If the contents of DAC Input Register D are read out, the next two bytes of data that are read are the contents of DAC Input Register A .

MULTIPLE DAC READBACK SEQUENCE

When reading data back from multiple AD5696/AD5694 DACs, the user begins with an address byte ($R/\bar{W} = 0$), after which the DAC

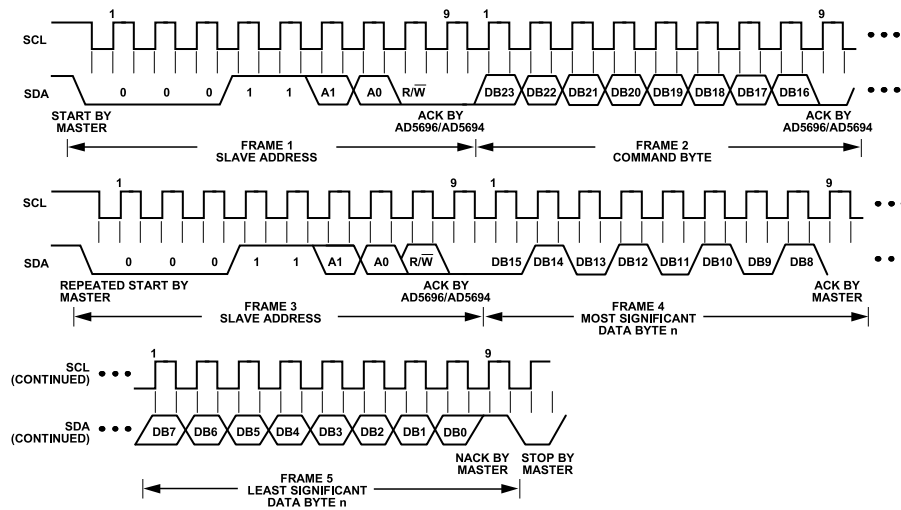

Figure 38. I²C Read Operation

THEORY OF OPERATION

POWER-DOWN OPERATION

Command 0100 is designated for the power-down function. The AD5696/AD5694 provide three separate power-down modes (see Table 11). These power-down modes are software programmable by setting Bit DB7 to Bit DB0 in the input shift register (see Table 12). Two bits are associated with each DAC channel. Table 11 shows how the state of these two bits corresponds to the mode of operation of the device.

Table 11. Modes of Operation

Operating Mode	PDx1	PDx0
Normal Operation	0	0
Power-Down Modes		
1 kΩ to GND	0	1
100 kΩ to GND	1	0
Three-State	1	1

Any or all DACs (DAC A to DAC D) can be powered down to the selected mode by setting the corresponding bits in the input shift register. See Table 12 for the contents of the input shift register during the power-down/power-up operation.

When both Bit PDx1 and Bit PDx0 (where x is the DAC selected) in the input shift register are set to 0, the parts work normally with their normal power consumption of 0.59 mA at 5 V. When Bit PDx1, Bit PDx0, or both Bit PDx1 and Bit PDx0 are set to 1, the part is in power-down mode. In power-down mode, the supply current falls to 4 μA at 5 V.

In power-down mode, the output stage is internally switched from the output of the amplifier to a resistor network of known values. In this way, the output impedance of the part is known when the part is in power-down mode.

Table 11 lists the three power-down options. The output is connected internally to GND through either a 1 kΩ or a 100 kΩ resistor, or it is left open-circuited (three-state). The output stage is illustrated in Figure 39.

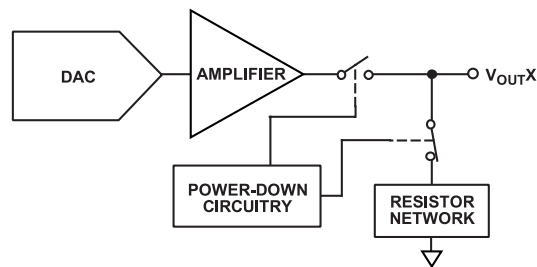

Figure 39. Output Stage During Power-Down

The bias generator, output amplifier, resistor string, and other associated linear circuitry are shut down when power-down mode is activated. However, the contents of the DAC registers are unaffected in power-down mode, and the DAC registers can be updated while the device is in power-down mode. The time required to exit power-down is typically 2.5 μs for V_{DD} = 5 V.

LOAD DAC (HARDWARE LDAC PIN)

The AD5696/AD5694 DACs have double buffered interfaces consisting of two banks of registers: input registers and DAC registers. The user can write to any combination of the input registers (see Table 9). Updates to the DAC registers are controlled by the LDAC pin.

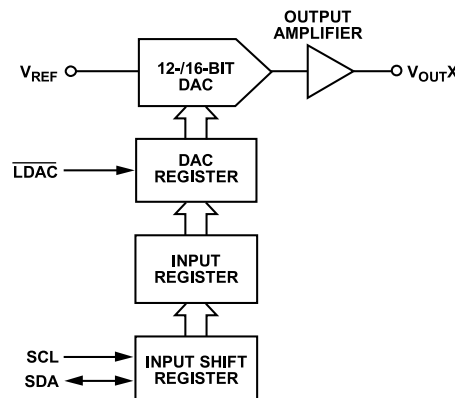

Figure 40. Simplified Diagram of Input Loading Circuitry for a Single DAC

Table 12. 24-Bit Input Shift Register Contents for Power-Down/Power-Up Operation¹

DB23 (MSB)	DB22	DB21	DB20	DB19 to DB16	DB15 to DB8	DB7	DB6	DB5	DB4	DB3	DB2	DB1	DB0 (LSB)
0	1	0	0	X	X	PDD1	PDD0	PDC1	PDC0	PDB1	PDB0	PDA1	PDA0
Command bits (C3 to C0)				Address bits (don't care)	Don't care	Power-down select, DAC D		Power-down select, DAC C		Power-down select, DAC B		Power-down select, DAC A	

¹ X = don't care.

THEORY OF OPERATION

Instantaneous DAC Updating ($\overline{\text{LDAC}}$ Held Low)

For instantaneous updating of the DACs, $\overline{\text{LDAC}}$ is held low while data is clocked into the input register using Command 0001. Both the addressed input register and the DAC register are updated on the 24th clock, and the output begins to change (see Table 14).

Deferred DAC Updating ($\overline{\text{LDAC}}$ Pulsed Low)

For deferred updating of the DACs, $\overline{\text{LDAC}}$ is held high while data is clocked into the input register using Command 0001. All DAC outputs are asynchronously updated by pulling $\overline{\text{LDAC}}$ low after the 24th clock. The update occurs on the falling edge of $\overline{\text{LDAC}}$.

$\overline{\text{LDAC}}$ MASK REGISTER

Command 0101 is reserved for the software $\overline{\text{LDAC}}$ function. When this command is executed, the address bits are ignored. When writing to the DAC using Command 0101, the 4-bit $\overline{\text{LDAC}}$ mask register (DB3 to DB0) is loaded. Bit DB3 of the $\overline{\text{LDAC}}$ mask register corresponds to DAC D; Bit DB2 corresponds to DAC C; Bit DB1 corresponds to DAC B; and Bit DB0 corresponds to DAC A.

The default value of these bits is 0; that is, the $\overline{\text{LDAC}}$ pin works normally. Setting any of these bits to 1 forces the selected DAC channel to ignore transitions on the $\overline{\text{LDAC}}$ pin, regardless of the state of the hardware $\overline{\text{LDAC}}$ pin. This flexibility is useful in applications where the user wishes to select which channels respond to the $\overline{\text{LDAC}}$ pin.

The $\overline{\text{LDAC}}$ mask register allows the user extra flexibility and control over the hardware $\overline{\text{LDAC}}$ pin (see Table 13). Setting the $\overline{\text{LDAC}}$ bit (DB3 to DB0) to 0 for a DAC channel allows the hardware $\overline{\text{LDAC}}$ pin to control the updating of that channel.

Table 13. $\overline{\text{LDAC}}$ Overwrite Definition

Load $\overline{\text{LDAC}}$ Register		
$\overline{\text{LDAC}}$ Bit (DB3 to DB0)	$\overline{\text{LDAC}}$ Pin	$\overline{\text{LDAC}}$ Operation
0	1 or 0	Determined by the $\overline{\text{LDAC}}$ pin.
1	X ¹	DAC channels are updated. (DAC channels see $\overline{\text{LDAC}}$ pin as 1.)

¹ X = don't care.

HARDWARE RESET PIN ($\overline{\text{RESET}}$)

$\overline{\text{RESET}}$ is an active low reset that allows the outputs to be cleared to either zero scale or midscale. The clear code value is user select-able via the reset select pin (RSTSEL). It is necessary to keep $\overline{\text{RESET}}$ low for a minimum of 30 ns to complete the operation.

When the $\overline{\text{RESET}}$ signal is returned high, the output remains at the cleared value until a new value is programmed. The outputs cannot be updated with a new value while the $\overline{\text{RESET}}$ pin is low.

There is also a software executable reset function that resets the DAC to the power-on reset code. Command 0110 is designated for this software reset function (see Table 8). Any events on $\overline{\text{LDAC}}$ during a power-on reset are ignored. If the $\overline{\text{RESET}}$ pin is pulled low at power-up, the device does not initialize correctly until the pin is released.

RESET SELECT PIN (RSTSEL)

The AD5696/AD5694 contain a power-on reset circuit that controls the output voltage during power-up. When the RSTSEL pin is tied to GND, the outputs power up to zero scale (note that this is outside the linear region of the DAC). When the RSTSEL pin is tied to V_{LOGIC} , the outputs power up to midscale. The outputs remain powered up at the level set by the RSTSEL pin until a valid write sequence is made to the DAC.

Table 14. Write Commands and $\overline{\text{LDAC}}$ Pin Truth Table¹

Command	Description	Hardware $\overline{\text{LDAC}}$ Pin State	Input Register Contents	DAC Register Contents
0001	Write to Input Register n (dependent on $\overline{\text{LDAC}}$)	V_{LOGIC}	Data update	No change (no update)
		GND ²	Data update	Data update
0010	Update DAC Register n with contents of Input Register n	V_{LOGIC}	No change	Updated with input register contents
		GND	No change	Updated with input register contents
0011	Write to and update DAC Channel n	V_{LOGIC}	Data update	Data update
		GND	Data update	Data update

¹ A high to low transition on the hardware $\overline{\text{LDAC}}$ pin always updates the contents of the DAC register with the contents of the input register on channels that are not masked (blocked) by the $\overline{\text{LDAC}}$ mask register.

² When the $\overline{\text{LDAC}}$ pin is permanently tied low, the $\overline{\text{LDAC}}$ mask bits are ignored.

APPLICATIONS INFORMATION

MICROPROCESSOR INTERFACING

Microprocessor interfacing to the AD5696/AD5694 is via a serial bus that uses a standard protocol that is compatible with DSP processors and microcontrollers. The communications channel requires a 2-wire interface consisting of a clock signal and a data signal.

AD5696/AD5694 TO ADSP-BF531 INTERFACE

The I²C interface of the AD5696/AD5694 is designed for easy connection to industry-standard DSPs and microcontrollers. Figure 41 shows the AD5696/AD5694 connected to the Analog Devices, Inc., Blackfin[®] processor. The Blackfin processor has an integrated I²C port that can be connected directly to the I²C pins of the AD5696/AD5694.

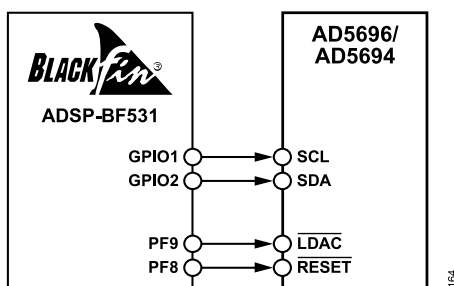

Figure 41. AD5696/AD5694 to ADSP-BF531 Interface

LAYOUT GUIDELINES

In any circuit where accuracy is important, careful consideration of the power supply and ground return layout helps to ensure the rated performance. The PCB on which the AD5696/AD5694 are mounted should be designed so that the AD5696/AD5694 lie on the analog plane.

The AD5696/AD5694 should have ample supply bypassing of 10 μ F in parallel with 0.1 μ F on each supply, located as close to the package as possible, ideally right up against the device. The 10 μ F capacitor is the tantalum bead type. The 0.1 μ F capacitor should have low effective series resistance (ESR) and low effective series inductance (ESI), such as the common ceramic types; these capacitors provide a low impedance path to ground at high frequencies to handle transient currents due to internal logic switching.

In systems where many devices are on one board, it is often useful to provide some heat sinking capability to allow the power to dissipate easily.

The AD5696/AD5694 LFCSP models have an exposed pad beneath the device. Connect this pad to the GND supply for the part. For optimum performance, use special considerations to design the motherboard and to mount the package.

For enhanced thermal, electrical, and board level performance, solder the exposed pad on the bottom of the LFCSP package to the corresponding thermal land paddle on the PCB. Design

thermal vias into the PCB land paddle area to further improve heat dissipation.

The GND plane on the device can be increased (as shown in Figure 42) to provide a natural heat sinking effect.

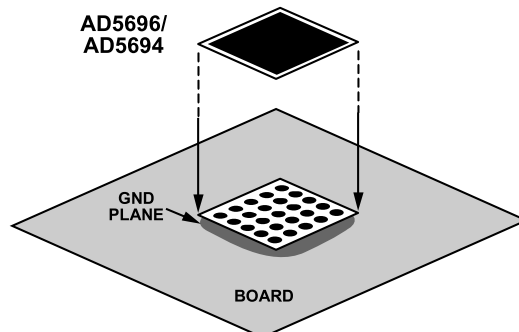

Figure 42. Paddle Connection to Board

GALVANICALLY ISOLATED INTERFACE

In many process control applications, it is necessary to provide an isolation barrier between the controller and the unit being controlled to protect and isolate the controlling circuitry from any hazardous common-mode voltages that may occur.

The Analog Devices iCoupler[®] products provide voltage isolation in excess of 2.5 kV. The serial loading structure of the AD5696/AD5694 makes the part ideal for isolated interfaces because the number of interface lines is kept to a minimum. Figure 43 shows a 4-channel isolated interface to the AD5696/AD5694 using the ADuM1400. For more information, visit www.analog.com/icouplers.

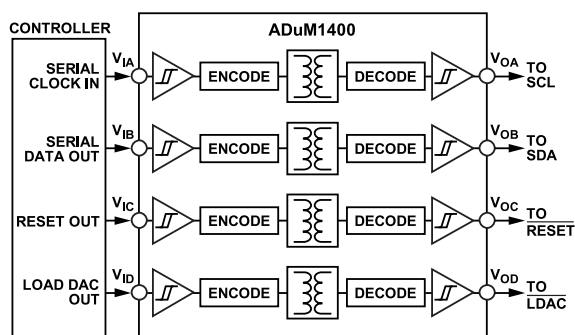

Figure 43. Isolated Interface

OUTLINE DIMENSIONS

Package Drawing (Option)	Package Type	Package Description
CP-16-22	LFCSP	16-Lead Lead Frame Chip Scale Package
RU-16	TSSOP	16-Lead Thin Shrink Small Outline Package

For the latest package outline information and land patterns (footprints), go to [Package Index](#).

Updated: February 26, 2024

ORDERING GUIDE

Model ¹	Temperature Range	Package Description	Packing Quantity	Package Option	Marking Code
AD5694ARUZ	-40°C to +105°C	16-Lead TSSOP		RU-16	
AD5694ARUZ-RL7	-40°C to +105°C	16-Lead TSSOP	Reel, 1000	RU-16	
AD5694BCPZ-RL7	-40°C to +105°C	16-Lead LFCSP (3mm x 3mm w/ EP)	Reel, 1500	CP-16-22	DJQ
AD5694BRUZ	-40°C to +105°C	16-Lead TSSOP		RU-16	
AD5694BRUZ-RL7	-40°C to +105°C	16-Lead TSSOP	Reel, 1000	RU-16	
AD5696ACPZ-RL7	-40°C to +105°C	16-Lead LFCSP (3mm x 3mm w/ EP)	Reel, 1500	CP-16-22	DJ8
AD5696ARUZ	-40°C to +105°C	16-Lead TSSOP		RU-16	
AD5696ARUZ-RL7	-40°C to +105°C	16-Lead TSSOP	Reel, 1000	RU-16	
AD5696BCPZ-RL7	-40°C to +105°C	16-Lead LFCSP (3mm x 3mm w/ EP)	Reel, 1500	CP-16-22	DJ9
AD5696BRUZ	-40°C to +105°C	16-Lead TSSOP		RU-16	
AD5696BRUZ-RL7	-40°C to +105°C	16-Lead TSSOP	Reel, 1000	RU-16	

¹ Z = RoHS Compliant Part.

RESOLUTION AND ACCURACY (INL) OPTIONS

Model ¹	Resolution	Accuracy (INL)
AD5696ACPZ-RL7	16 Bits	±8 LSB
AD5696BCPZ-RL7	16 Bits	±2 LSB
AD5696ARUZ	16 Bits	±8 LSB
AD5696ARUZ-RL7	16 Bits	±8 LSB
AD5696BRUZ	16 Bits	±2 LSB
AD5696BRUZ-RL7	16 Bits	±2 LSB
AD5694BCPZ-RL7	12 Bits	±1 LSB
AD5694ARUZ	12 Bits	±2 LSB
AD5694ARUZ-RL7	12 Bits	±2 LSB
AD5694BRUZ	12 Bits	±1 LSB
AD5694BRUZ-RL7	12 Bits	±1 LSB

¹ Z = RoHS Compliant Part.

EVALUATION BOARDS

Model ¹	Description
EVAL-AD5696RARDZ	AD5696 TSSOP Evaluation Board
EVAL-AD5694RSDZ	AD5694 TSSOP Evaluation Board

¹ Z = RoHS Compliant Part.

I²C refers to a communications protocol originally developed by Philips Semiconductors (now NXP Semiconductors).

Looking for pricing, stock, or lifecycle information?

Click below to explore more details on WIN SOURCE:

 [View AD5696BRUZ on WIN SOURCE](#)

 [Analog Devices Inc. Information](#)

Optimize Your Supply Chain with WIN SOURCE Solutions

-  Global Sourcing Solution
-  Obsolete Management
-  Cost Control Management
-  Shortage Management
-  Alternative Solution
-  Excess Inventory Management