



**THE DATASHEET OF
MPQ8903DJ-3.3-LF-Z**



DESCRIPTION

The MPQ8903 is a 150mA low-dropout linear regulator that can operate from 2.7V to 6.5V input. It regulates the output with 2% accuracy and comes with preset 2.5V, 2.85V or 3.3V output. An external resistor divider may be used to adjust the output voltage from 1.25V to 5V.

The MPQ8903 has thermal protection to guard against harsh operating conditions, and is available in 5-pin TSOT23 package.

FEATURES

- Guaranteed Industrial Operating Temperature Range Limits
- 2.7V to 6.5V Input Voltage Range
- Fixed Output Voltage Options of 2.5V, 2.85V or 3.3V
- Adjustable Output Voltage from 1.25V to 5V using an External Resistor Divider
- Low 100mV Dropout at 100mA Output
- 2% Accurate Output Voltage
- Stable With Low-ESR Output Capacitors
- Thermal Protection
- Available in TSOT23-5 Package

APPLICATIONS

- 802.11 PC Cards
- Mobile Handset PLL Power
- Audio Codec Power

"MPS" and "The Future of Analog IC Technology" are Registered Trademarks of Monolithic Power Systems, Inc.

TYPICAL APPLICATION

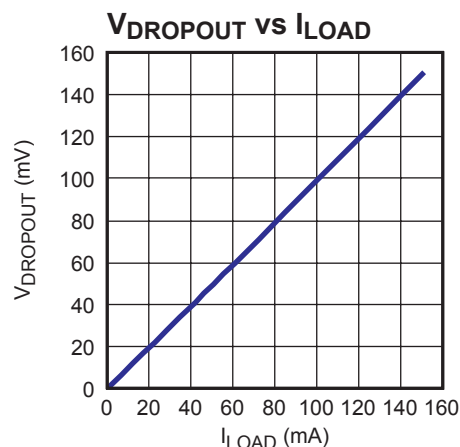
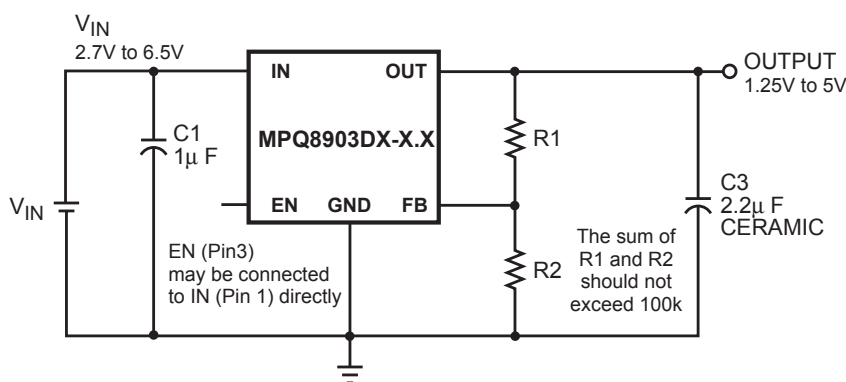

ORDERING INFORMATION

Part Number*	Package	Top Marking	Free Air Temperature (T _A)
MPQ8903DJ-2.5	TSOT23-5	R4	-40°C to +85°C
MPQ8903DJ-2.85		R5	
MPQ8903DJ-3.3		R6	

* For Tape & Reel, add suffix -Z (e.g. MPQ8903DJ-2.85-Z)
 For RoHS Compliant Packaging, add suffix -LF (e.g. MPQ8903DJ-2.85-LF-Z)

PACKAGE REFERENCE

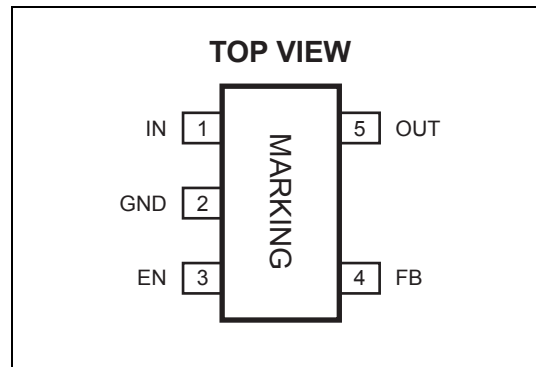

ABSOLUTE MAXIMUM RATINGS ⁽¹⁾

IN Supply Voltage	-0.3V to +7.0V
FB Voltage	-0.3V to V _{OUT} + 0.3V
All Other Pins	-0.3V to +6V
Continuous Power Dissipation (T _A = +25°C) ⁽²⁾	0.56W
Junction Temperature	150°C
Lead Temperature	260°C
Storage Temperature	-65°C to +150°C

Recommended Operating Conditions ⁽³⁾

Input Voltage.....	2.7V to 6.5V
Output Voltage.....	1.25V to 5V
Load Current.....	150mA Maximum
Operating Junct. Temp (T _J).....	-40°C to +125°C

Thermal Resistance ⁽⁴⁾	θ_{JA}	θ_{JC}
TSOT23-5	220	110 .. °C/W

Notes:

- 1) Exceeding these ratings may damage the device.
- 2) The maximum allowable power dissipation is a function of the maximum junction temperature T_J(MAX), the junction-to-ambient thermal resistance θ_{JA} , and the ambient temperature T_A. The maximum allowable continuous power dissipation at any ambient temperature is calculated by P_D(MAX)=(T_J(MAX)-T_A)/ θ_{JA} . Exceeding the maximum allowable power dissipation will cause excessive die temperature, and the regulator will go into thermal shutdown. Internal thermal shutdown circuitry protects the device from permanent damage.
- 3) The device is not guaranteed to function outside of its operating conditions.
- 4) Measured on JESD51-7, 4-layer PCB.

ELECTRICAL CHARACTERISTICS

$V_{IN} = 5V$, $T_A = +25^{\circ}C$, unless otherwise noted.

Parameter	Symbol	Condition	Min	Typ	Max	Units
Operating Voltage		$I_{OUT} = 1mA$	2.7		6.5	V
Output Voltage Accuracy		$I_{OUT} = 1mA$ $V_{OUT} = 1.5V$ to $5V$ $-40^{\circ}C \leq T_A \leq +85^{\circ}C$		± 1.0	± 2.0	%
				± 1.0	± 3.0	
Shutdown Current		$V_{EN} = 0V$, $V_{IN} = 5V$ $-40^{\circ}C \leq T_A \leq +85^{\circ}C$		0.1	1	μA
				0.1	2	
FB Regulation Voltage		$-40^{\circ}C \leq T_A \leq +85^{\circ}C$	1.197	1.222	1.246	V
			1.194	1.222	1.249	
Dropout Voltage ⁽⁶⁾		$I_{OUT} = 150mA$	$V_{OUT} = 3V$	150		mV
			$V_{OUT} = 4V$	125		
Line Regulation		$I_{OUT} = 1mA$, $V_{IN} = (V_{OUT} + 0.5V)$ to $6.5V$ ⁽⁷⁾ $-40^{\circ}C \leq T_A \leq +85^{\circ}C$		0.005	0.08	%/V
				0.005	0.11	
Load Regulation		$I_{OUT} = 1mA$ to $150mA$, $V_{IN} = V_{OUT} + 0.5V$ ⁽⁷⁾ $-40^{\circ}C \leq T_A \leq +85^{\circ}C$		0.001	0.02	%/mA
				0.001	0.03	
PSRR		$V_{IN} > V_{OUT} + 0.5V$, $C3 = 2.2\mu F$, $V_{IN(AC)} = 100mV$, $f = 1kHz$ ⁽⁵⁾		50		dB
			$V_{IN} > V_{OUT} + 0.5V$, $C3 = 2.2\mu F$, $V_{IN(AC)} = 100mV$, $f = 1MHz$ ⁽⁵⁾		20	
EN Input High Voltage					1.5	V
EN Input Low Voltage			0.4			V
EN Input Bias Current		$V_{EN} = 0V$ $-40^{\circ}C \leq T_A \leq +85^{\circ}C$		0.01	1	μA
				0.01	2	
Thermal Protection ⁽⁵⁾				155		$^{\circ}C$
Thermal Protection Hysteresis ⁽⁵⁾				30		$^{\circ}C$

Notes:

5) Parameter is guaranteed by design, not production tested.

6) Dropout Voltage is defined as the input to output differential when the output voltage drops 1% below its normal value.

7) $V_{IN} = 2.7V$ for $V_{OUT} = 1.25V$ to $2.2V$

TYPICAL PERFORMANCE CHARACTERISTICS

$V_{IN} = 4.5V$, $V_{OUT} = 2.85V$, $C1 = 1\mu F$, $C2 = 0.1\mu F$, $C3 = 2.2\mu F$, $T_A = +25^\circ C$ unless otherwise noted.

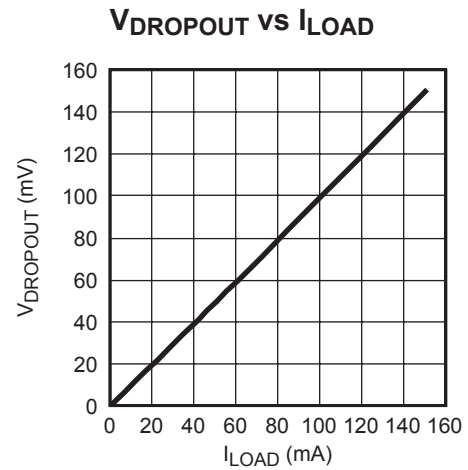
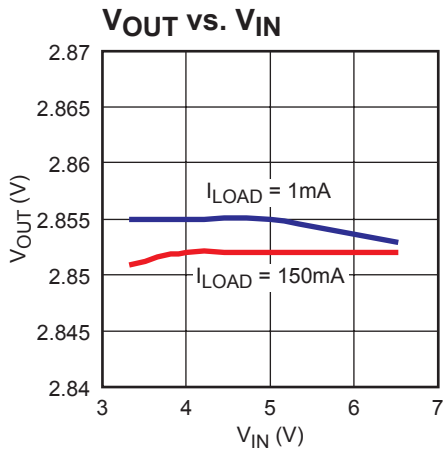
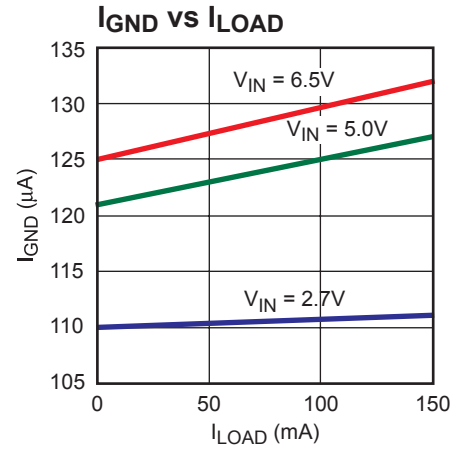
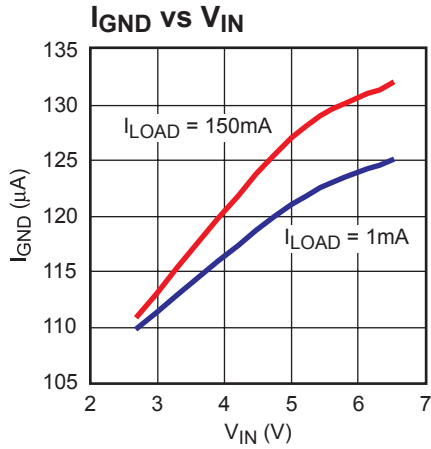

PIN FUNCTIONS

TSOT23-5 Pin #	Name	Description
2	GND	Ground.
3	EN	Enable Input. Drive EN high to turn on the MPQ8903; low to turn it off. For automatic startup, connect EN to IN.
1	IN	Power Source Input. IN supplies the internal power to the MPQ8903 and is the source of the pass transistor. Bypass IN to GND with a 1µF or greater capacitor.
5	OUT	Regulator Output. OUT is the output of the linear regulator. Bypass OUT to GND with a 1µF or greater capacitor.
	NC	No Connect.
4	FB	Feedback Input. Connect a resistive voltage divider from OUT to FB to set the output voltage. The OUT feedback threshold is 1.222V.

OPERATION

The MPQ8903 is a low-current, low-dropout linear regulator. The MPQ8903 uses a PMOS pass element and features internal thermal shutdown. The normally fixed output MPQ8903 may be converted to an adjustable output device

by applying a resistor divider network as shown in Figure 2. An optional feed-forward capacitor, C_{BYP} , may be added for an improved transient response.

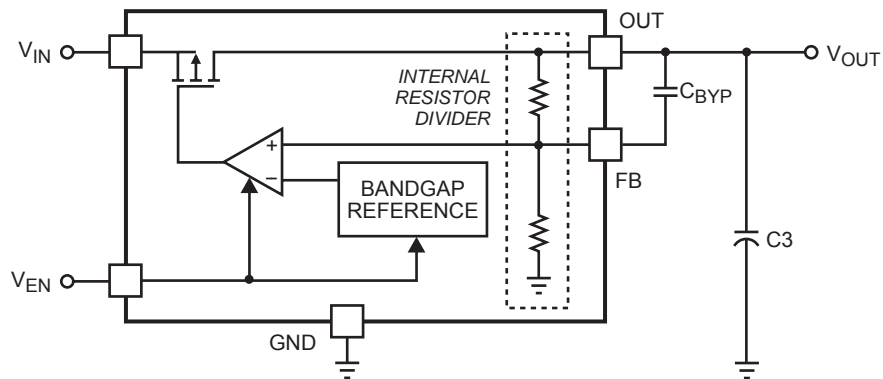

Figure 1—Fixed Output Regulator

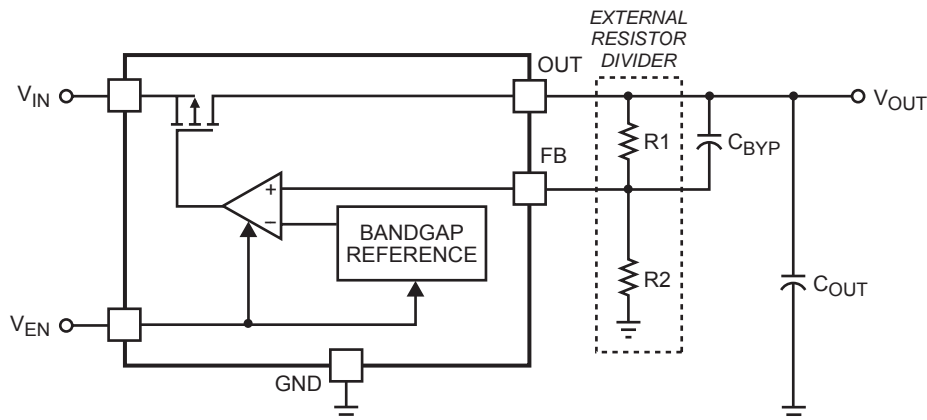

Figure 2—Adjustable Regulator: $V_{OUT} = V_{FB}(1+(R1/R2))$

APPLICATION INFORMATION

Setting the Output Voltage

The fixed output voltage of the MPQ8903 is set to 2.5V, 2.85V or 3.3V, depending on the internal resistor divider (Figure 1). You can also adjust the output voltage by using an external resistor divider (R1 and R2 in Figure 2). However, the sum of R1 and R2 should not exceed 100kΩ in order to minimize the impact of the internal resistor divider. For an accurate output-voltage setting, use 10kΩ (±1%) for the low-side resistor R2 of the voltage divider, while the high-side resistor R1 can be determined by the equation:

$$R1 = R2 \times \left(\frac{V_{OUT} - V_{FB}}{V_{FB}} \right)$$

Where V_{FB} is the OUT feedback threshold voltage equal to 1.222V.

Example: For 2.5V Output

$$R1 = \frac{2.5V - 1.222V}{\left(\frac{1.222V}{10k\Omega} \right)} = 10.41k\Omega$$

You can select a standard 10.5kΩ (±1%) resistor for R1.

The following table lists the selected R1 values for some typical output voltages:

Table 1—Adjustable Output Voltage R1 Values

V _{OUT} (V)	R1 (Ω)	R2 (Ω)
1.25	232	10k
1.5	2.26k	
1.8	4.75k	
2	6.34k	
2.5	10.5k	
2.8	13k	
3	14.7k	
3.3	16.9k	
4	22.6k	
5	30.9k	

In Figures 3 and 4, C2 is added for an improved transient response.

Input Capacitor Selection

For proper operation, place a ceramic capacitor (C1) between 1μF and 10μF of dielectric type X5R or X7R between the input pin and ground. Larger values in this range will help improve line transient response at the drawback of increased size.

Output Capacitor Selection

For stable operation, use a ceramic capacitor (C3) of type X5R or X7R between 1μF and 10μF. Larger values in this range will help improve load transient response and reduce noise with the drawback of increased size. Output capacitors of other dielectric types may be used, but are not recommended as their capacitance can deviate greatly from their rated value over temperature.

To improve load transient response, add a small ceramic (X5R, X7R or Y5V dielectric) 100nF feed forward capacitor in parallel with R1. The feed forward capacitor is not required for stable operation.

PCB layout guide

PCB layout is very important to achieve good regulation, ripple rejection, transient response and thermal performance. It is highly recommended to duplicate EVB layout for optimum performance.

If change is necessary, please follow these guidelines and take figure 5 for reference.

- 1) Input and output bypass ceramic capacitors are suggested to be put close to the IN Pin and OUT Pin respectively.
- 2) Ensure all feedback connections are short and direct. Place the feedback resistors and compensation components as close to the chip as possible.
- 3) Connect IN, OUT and especially GND respectively to a large copper area to cool the chip to improve thermal performance and long-term reliability.

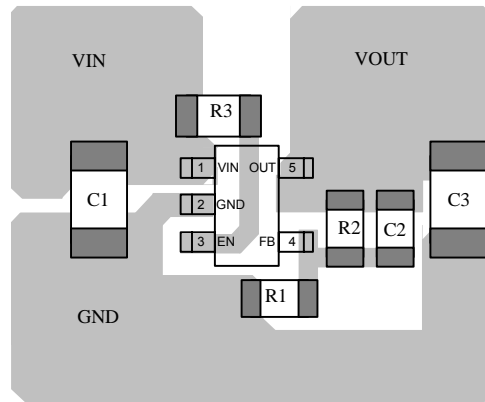
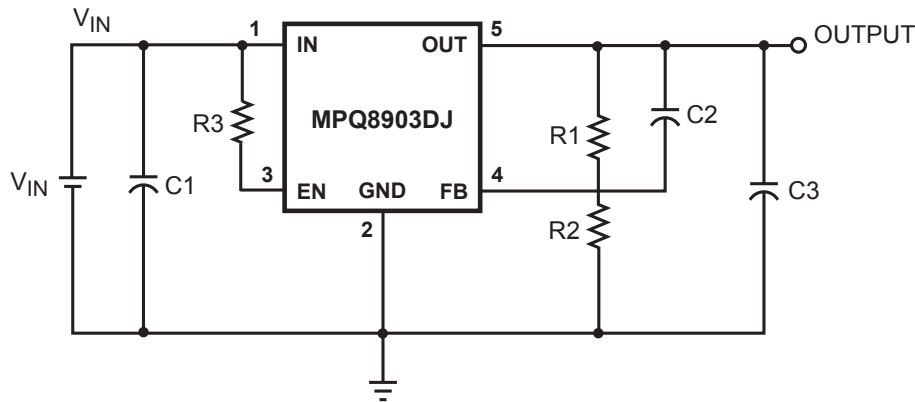

Top Layer

Figure 3—PCB Layout

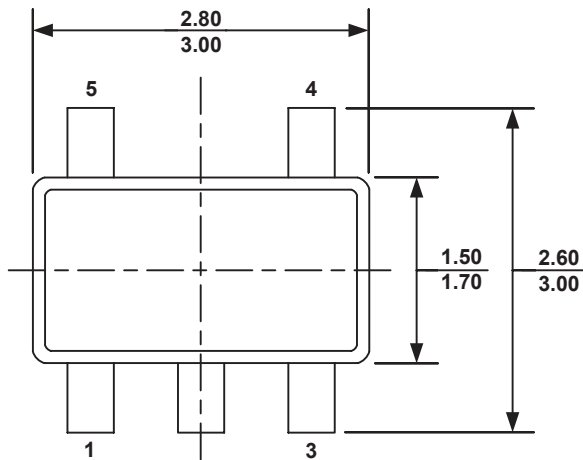
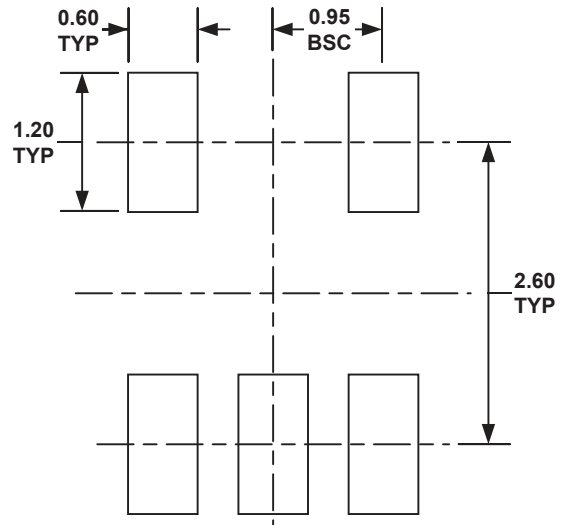
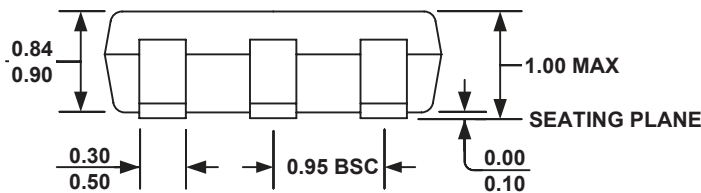
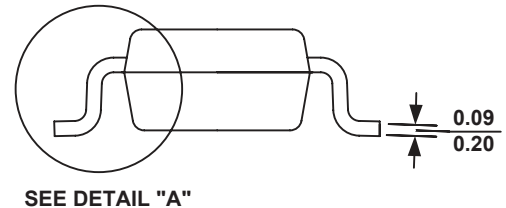
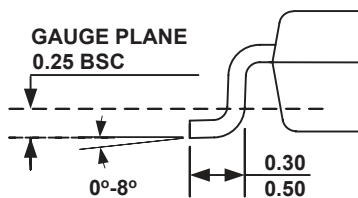
PACKAGE INFORMATION
TSOT23-5

TOP VIEW

RECOMMENDED LAND PATTERN

FRONT VIEW

SIDE VIEW

DETAIL A
NOTE:

- 1) ALL DIMENSIONS ARE IN MILLIMETERS.
- 2) PACKAGE LENGTH DOES NOT INCLUDE MOLD FLASH, PROTRUSION OR GATE BURR.
- 3) PACKAGE WIDTH DOES NOT INCLUDE INTERLEAD FLASH OR PROTRUSION.
- 4) LEAD COPLANARITY (BOTTOM OF LEADS AFTER FORMING) SHALL BE 0.10 MILLIMETERS MAX.
- 5) DRAWING CONFORMS TO JEDEC MO-193, VARIATION AA.
- 6) DRAWING IS NOT TO SCALE.

NOTICE: The information in this document is subject to change without notice. Users should warrant and guarantee that third party Intellectual Property rights are not infringed upon when integrating MPS products into any application. MPS will not assume any legal responsibility for any said applications.

Looking for pricing, stock, or lifecycle information?

Click below to explore more details on WIN SOURCE:

- ⊖ [View MPQ8903DJ-3.3-LF-Z on WIN SOURCE](#)
- ⊖ [Monolithic Power Systems Inc. Information](#)

Optimize Your Supply Chain with WIN SOURCE Solutions

- ✓ Global Sourcing Solution
- ✓ Obsolete Management
- ✓ Cost Control Management
- ✓ Shortage Management
- ✓ Alternative Solution
- ✓ Excess Inventory Management