



**THE DATASHEET OF  
BD4271FP2-CE2**



# LDO Regulators with Watchdog Timer and Voltage Detector

## 550 mA Output LDO Regulator with WDT and Voltage Detector

**BD4271xxx-C Series**

### General Description

BD4271xxx-C Series are automotive voltage regulators with watchdog timer and offers the output current of 550 mA while limiting the quiescent current low. A logical "HIGH" at the CTL pin enables the LDO regulator and "LOW" disables the LDO regulator and keeps current consumption low.

A reset signal is generated for an output voltage  $V_O$  of Typ 4.65 V.

The reset delay time and watchdog time (WDT) can be programmed by the external capacitor.

### Features

- Low ESR ceramic capacitors applicable for output
- Low drop voltage: PDMOS output transistor
- Power on and under-voltage reset
- Programmable reset delay and watchdog time by external capacitor

### Applications

- Onboard Vehicle Device  
(Engine ECU, Body-control, Car Stereos, Satellite Navigation System, etc.)

### Key Specifications

- AEC-Q100 qualified (Note 1)
- Functional Safety Supportive Automotive Products
- Qualified for Automotive Applications
- Wide Temperature Range (T<sub>J</sub>): -40 °C to +150 °C
- Wide Operating Input Range: -0.3 V to +45 V
- Low Quiescent Current: 75 μA (Typ)
- Output Load Current: 550 mA
- Output Voltage: 5.0 V (Typ) ± 2 %
- Reset Detection Voltage Accuracy: 4.53 V to 4.77 V  
4.65 V (Typ)
- Enable input
- Over Current Protection (OCP)
- Thermal Shutdown (TSD)  
(Note1: Grade 1)

### Packages

- HFP: HRP7
- FP2: TO263-7
- EFJ: HTSOP-J8

**W (Typ) x D (Typ) x H (Max)**

- 9.395 mm x 10.540 mm x 2.005 mm
- 10.00 mm x 14.95 mm x 4.50 mm
- 4.9 mm x 6.0 mm x 1.0 mm



HRP7



TO263-7



HTSOP-J8

### Typical Application Circuit

$C_{IN} \geq 0.1 \mu\text{F}$ ,  $C_{CT} = 0.001 \mu\text{F}$  to  $10 \mu\text{F}$ ,  $C_O \geq 6 \mu\text{F}$

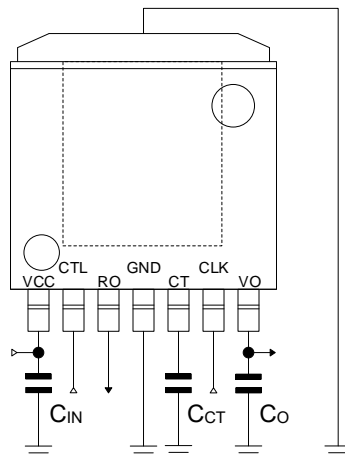

○Product structure : Silicon integrated circuit ○This product has no designed protection against radioactive rays.

Pin Configurations (BD4271HFP-C, BD4271FP2-C)

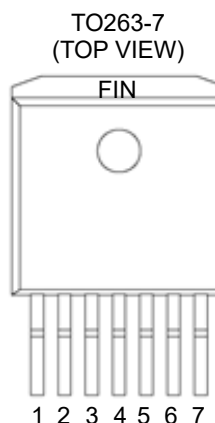
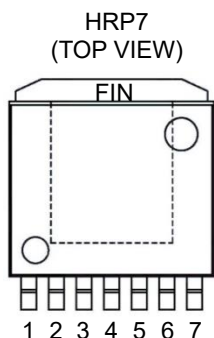

Pin Description (BD4271HFP-C, BD4271FP2-C)

Pin No.	Pin Name	Function
1	VCC	Input
2	CTL	Output control
3	RO	Reset output
4	GND	Ground
5	CT	Setting Reset Delay Time and WDT time
6	CLK	Input CLK from Microcomputer
7	VO	Output
FIN	GND	Ground

Pin Configuration (BD4271EFJ-C)

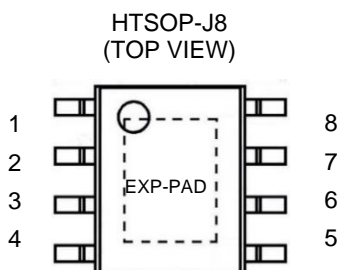

Pin Description (BD4271EFJ-C)

Pin No.	Pin Name	Function
1	VCC	Input
2	CTL	Output control
3	N.C	No Connection <sup>(Note 1)</sup>
4	RO	Reset output
5	GND	Ground
6	CLK	Input CLK from Microcomputer
7	CT	Setting Reset Delay Time and WDT time
8	VO	Output
EXP-PAD	EXP-PAD	No Connection <sup>(Note 2)</sup>

(Note 1) This pin is not connected to the chip. It can keep open or it's also possible to connect to GND.  
 If Pin No.3 is shorted to GND, Pin No.3 will be adjacent to Pin No.2 CTL and Pin No.4 RO on the board layout.  
 If adjacent pins are expected to be shorted, please confirm if there is any problem with the actual application.

(Note 2) It is recommended to connect the EXP-PAD to the GND pattern to improve heat dissipation.

Block Diagram

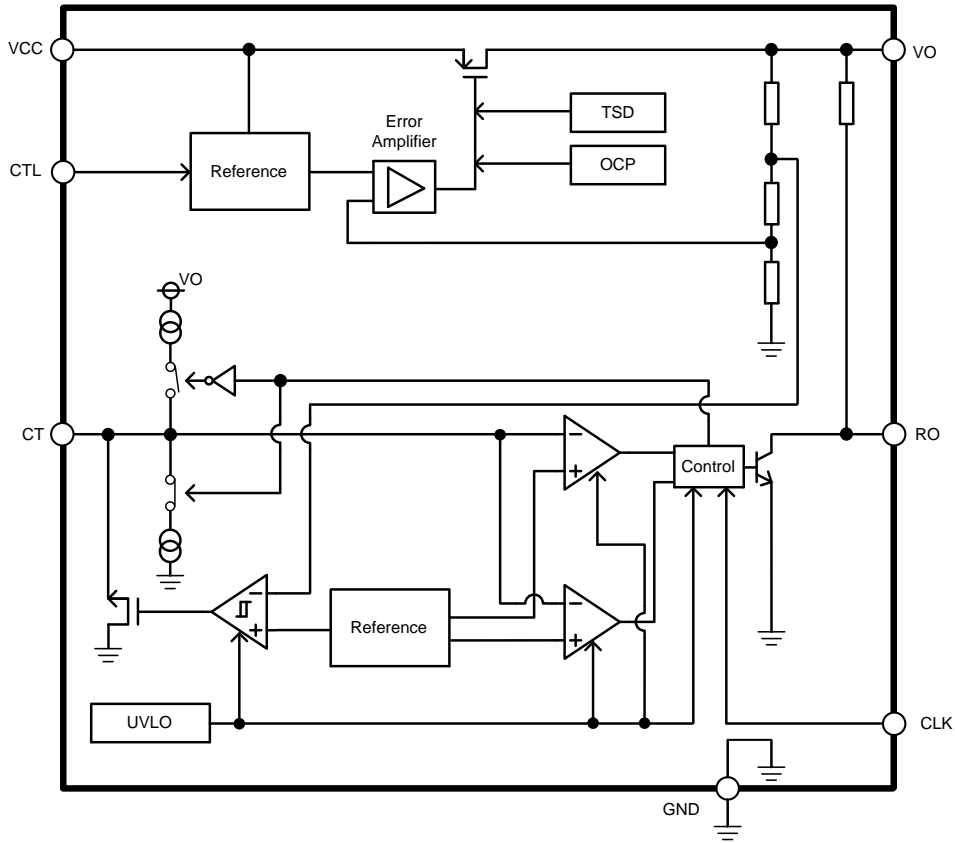

Block Descriptions

Block Name	Function	Description of Blocks
TSD	Thermal shutdown protection	The TSD protects the device from overheating. If the chip temperature (Tj) reaches ca. 175 °C (Typ), the output is turned off.
Reference	Reference voltage	The Reference generates the Reference Voltage.
OCP	Over current protection	The OCP protects the device from damage caused by over current.
UVLO	Under voltage lock out	The UVLO prevents malfunction of the reset block in case of very low output voltage.
Error Amplifier	Error amplifier	The Error Amplifier amplifies the difference between the feedback voltage of the output voltage and the reference voltage.
Control	RESET + WDT time control	The reset delay time and watchdog time can be programmed.

## Absolute Maximum Ratings

Parameter	Symbol	Ratings	Unit
Supply Voltage	V <sub>CC</sub>	-0.3 to +45.0	V
Output Control Voltage	V <sub>CTL</sub>	-0.3 to +45.0	V
RO Voltage	V <sub>RO</sub>	-0.3 to +7.0 ( $\leq V_O + 0.3$ )	V
Output Voltage	V <sub>O</sub>	-0.3 to +7.0	V
CLK Voltage	V <sub>CLK</sub>	-0.3 to V <sub>O</sub> + 0.3	V
Junction Temperature Range	T <sub>j</sub>	-40 to +150	°C
Storage Temperature Range	T <sub>stg</sub>	-55 to +150	°C
Maximum Junction Temperature	T <sub>jmax</sub>	+150	°C

**Caution:** Exceeding the absolute maximum rating for supply voltage, operating temperature or other parameters can result in damages to or destruction of the chip. In this event it also becomes impossible to determine the cause of the damage (e.g. short circuit, open circuit, etc.). Therefore, if any special mode is being considered with values expected to exceed the absolute maximum ratings, implementing physical safety measures, such as adding fuses, should be considered.

## Recommended Operating Conditions

Parameter	Symbol	Min	Max	Unit
Supply Voltage (I <sub>o</sub> ≤ 300 mA)	V <sub>CC</sub>	5.5	45.0	V
Supply Voltage (I <sub>o</sub> ≤ 550 mA)	V <sub>CC</sub>	6.0	45.0	V
Output Control Voltage	V <sub>CTL</sub>	0	45.0	V
Start -Up Voltage <i>(Note 1)</i>	V <sub>CC</sub>	3.0	—	V
Output Current	I <sub>o</sub>	0	550	mA
Operating Ratings Temperature	T <sub>a</sub>	-40	+125	°C

*(Note 1)* When I<sub>o</sub> = 0 mA.

**Thermal Resistance**<sup>(Note 1)</sup>

Parameter	Symbol	Thermal Resistance (Typ)		Unit
		1s <sup>(Note 3)</sup>	2s2p <sup>(Note 4)</sup>	
<b>HRP7</b>				
Junction to Ambient	$\theta_{JA}$	96.0	22.0	°C/W
Junction to Top Characterization Parameter <sup>(Note 2)</sup>	$\Psi_{JT}$	6	2	°C/W
<b>TO263-7</b>				
Junction to Ambient	$\theta_{JA}$	80.7	20.3	°C/W
Junction to Top Characterization Parameter <sup>(Note 2)</sup>	$\Psi_{JT}$	8	2	°C/W
<b>HTSOP-J8</b>				
Junction to Ambient	$\theta_{JA}$	131.7	33.0	°C/W
Junction to Top Characterization Parameter <sup>(Note 2)</sup>	$\Psi_{JT}$	12	5	°C/W

<sup>(Note 1)</sup> Based on JESD51-2A (Still-Air)

<sup>(Note 2)</sup> The thermal characterization parameter to report the difference between junction temperature and the temperature at the top center of the outside surface of the component package.

<sup>(Note 3)</sup> Using a PCB board based on JESD51-3.

<sup>(Note 4)</sup> Using a PCB board based on JESD51-5, 7.

Layer Number of Measurement Board	Material	Board Size
Single	FR-4	114.3 mm x 76.2 mm x 1.57 mmt

Top	
Copper Pattern	Thickness
Footprints and Traces	70 $\mu$ m

Layer Number of Measurement Board	Material	Board Size	Thermal Via <sup>(Note 5)</sup>	
			Pitch	Diameter
4 Layers	FR-4	114.3 mm x 76.2 mm x 1.6 mmt	1.20 mm	$\Phi$ 0.30 mm

Top		2 Internal Layers		Bottom	
Copper Pattern	Thickness	Copper Pattern	Thickness	Copper Pattern	Thickness
Footprints and Traces	70 $\mu$ m	74.2 mm x 74.2 mm	35 $\mu$ m	74.2 mm x 74.2 mm	70 $\mu$ m

<sup>(Note 5)</sup> This thermal via connects with the copper pattern of all layers.

**Electrical Characteristics (LDO)**

(Unless otherwise specified,  $T_j = -40\text{ }^{\circ}\text{C}$  to  $+150\text{ }^{\circ}\text{C}$ ,  $V_{CC} = 13.5\text{ V}$ ,  $V_{CTL} = 5\text{ V}$ ,  $I_o = 0\text{ mA}$ , the typical value is defined at  $T_j = +25\text{ }^{\circ}\text{C}$ )

Parameter	Symbol	Limit			Unit	Conditions
		Min	Typ	Max		
Circuit Current	$I_{CC}$	—	75	150	$\mu\text{A}$	$I_o = 0\text{ mA}$
Standby Current	$I_{ST}$	—	2.0	9.0	$\mu\text{A}$	$V_{CTL} = 0\text{ V}$ $T_j \leq 125\text{ }^{\circ}\text{C}$
Output Voltage	$V_O$	4.90	5.00	5.10	V	$6\text{ V} \leq V_{CC} \leq 40\text{ V}$ $0\text{ mA} \leq I_o \leq 300\text{ mA}$
Output Voltage	$V_O$	4.90	5.00	5.10	V	$8\text{ V} \leq V_{CC} \leq 26\text{ V}$ $I_o \leq 550\text{ mA}$
Dropout Voltage	$\Delta V_d$	—	0.2	0.5	V	$V_{CC} = 4.75\text{ V}$ $I_o = 300\text{ mA}$
Ripple Rejection	R.R.	—	60	—	dB	$f = 120\text{ Hz}$ , $e_{in} = 1\text{ V}_{rms}$ $I_o = 100\text{ mA}$
Line Regulation	Reg.I	-30	—	30	mV	$8\text{ V} \leq V_{CC} \leq 16\text{ V}$
Load Regulation	Reg.L	—	10	40	mV	$10\text{ mA} \leq I_o \leq 300\text{ mA}$
Thermal Shutdown	TSD	—	175	—	$^{\circ}\text{C}$	$T_j$ at TSD ON
Over Current Protection	$I_o$	550	—	—	mA	
CTL ON Mode Voltage	$V_{thH}$	2.7	—	—	V	Active Mode
CTL OFF Mode Voltage	$V_{thL}$	—	—	0.8	V	Off Mode
CTL Input Current	$I_{CTL}$	—	15	30	$\mu\text{A}$	$V_{CTL} = 5\text{ V}$

**Electrical Characteristics (Reset, WDT Function)**

(Unless otherwise specified,  $T_j = -40\text{ }^\circ\text{C}$  to  $+150\text{ }^\circ\text{C}$ ,  $V_{CC} = 13.5\text{ V}$ ,  $V_{CTL} = 5\text{ V}$ ,  $I_o = 0\text{ mA}$ , the typical value is defined at  $T_j = +25\text{ }^\circ\text{C}$ )

Parameter	Symbol	Limit			Unit	Conditions
		Min	Typ	Max		
Reset Detection Voltage	$V_{RT}$	4.53	4.65	4.77	V	—
Reset Detection Hysteresis	$V_{RHYS}$	25	60	100	mV	—
Reset Pull-up Resistance	$R_{RO}$	18	30	46	k $\Omega$	—
Reset Low Voltage	$V_{RO}$	—	—	0.4	V	—
CT Upper-side Threshold	$V_{CT\_H}$	—	1.80	—	V	—
CT Lower-side Threshold	$V_{CT\_L}$	—	0.45	—	V	—
CT Charge Current	$I_{CT\_C}$	—	16	—	$\mu\text{A}$	$V_{CT} = 0.15\text{ V}$
CT Discharge Current	$I_{CT\_D}$	—	3	—	$\mu\text{A}$	$V_{CT} = 1.35\text{ V}$
Delay Time L→H	$t_d$	8	11.5	16	ms	$C_{CT} = 0.1\text{ }\mu\text{F}$ (Note 1)
WDT Monitor Time	$t_{WH}$	30	45	66	ms	$C_{CT} = 0.1\text{ }\mu\text{F}$ (Note 1)
WDT Reset Time	$t_{WL}$	5	9	15	ms	$C_{CT} = 0.1\text{ }\mu\text{F}$ (Note 1)
CLK Input High Level Voltage	$V_{HCLK}$	$V_O$ $\times 0.8$	—	$V_O$	V	
CLK Input Low Level Voltage	$V_{LCLK}$	0	—	$V_O$ $\times 0.3$	V	CLK is pulled down inside the IC when CLK open.
CLK Input Current	$I_{CLK}$	1.5	5	15	$\mu\text{A}$	$V_{CLK} = 5\text{ V}$
CLK Input Pulse Width	$t_{PCLK}$	3	—	—	$\mu\text{s}$	
Minimum Operation Voltage	$V_{OPR}$	1	—	—	V	$RO < 0.5\text{ V}$

(Note 1)  $t_d$ ,  $t_{WH}$ , and  $t_{WL}$  can be varied by changing the CT capacitance value. (0.001  $\mu\text{F}$  to 10  $\mu\text{F}$  available)

$t_{d1}$  (ms)  $\approx t_d$  (the Delay Time at 0.1  $\mu\text{F}$ )  $\times C_{CT}$  ( $\mu\text{F}$ ) / 0.1

for example: when  $C_{CT} = 1\text{ }\mu\text{F}$ ,  $80\text{ ms} \leq t_d \leq 160\text{ ms}$

CT Capacitor:  $0.1\text{ }\mu\text{F} \leq C_{CT} \leq 10\text{ }\mu\text{F}$

$t_{WH1}$  (ms)  $\approx t_{WH}$  (the WDT Monitor Time at 0.1  $\mu\text{F}$ )  $\times C_{CT}$  ( $\mu\text{F}$ ) / 0.1

for example: when  $C_{CT} = 1\text{ }\mu\text{F}$ ,  $300\text{ ms} \leq t_{WH} \leq 660\text{ ms}$

CT Capacitor:  $0.1\text{ }\mu\text{F} \leq C_{CT} \leq 10\text{ }\mu\text{F}$

$t_{WL1}$  (ms)  $\approx t_{WL}$  (the WDT Reset Time at 0.1  $\mu\text{F}$ )  $\times C_{CT}$  ( $\mu\text{F}$ ) / 0.1

for example: when  $C_{CT} = 1\text{ }\mu\text{F}$ ,  $50\text{ ms} \leq t_{WL} \leq 150\text{ ms}$

CT Capacitor:  $0.1\text{ }\mu\text{F} \leq C_{CT} \leq 10\text{ }\mu\text{F}$

$t_{d2}$  (ms)  $\approx t_d$  (the Delay Time at 0.1  $\mu\text{F}$ )  $\times C_{CT}$  ( $\mu\text{F}$ ) / 0.1  $\pm 0.1$

for example: when  $C_{CT} = 0.01\text{ }\mu\text{F}$ ,  $0.7\text{ ms} \leq t_d \leq 1.7\text{ ms}$

CT Capacitor:  $0.001\text{ }\mu\text{F} \leq C_{CT} < 0.1\text{ }\mu\text{F}$

$t_{WH2}$  (ms)  $\approx t_{WH}$  (the WDT Monitor Time at 0.1  $\mu\text{F}$ )  $\times C_{CT}$  ( $\mu\text{F}$ ) / 0.1  $\pm 0.1$

for example: when  $C_{CT} = 0.01\text{ }\mu\text{F}$ ,  $2.9\text{ ms} \leq t_{WH} \leq 6.7\text{ ms}$

CT Capacitor:  $0.001\text{ }\mu\text{F} \leq C_{CT} < 0.1\text{ }\mu\text{F}$

$t_{WL2}$  (ms)  $\approx t_{WL}$  (the WDT Reset Time at 0.1  $\mu\text{F}$ )  $\times C_{CT}$  ( $\mu\text{F}$ ) / 0.1  $\pm 0.1$

for example: when  $C_{CT} = 0.01\text{ }\mu\text{F}$ ,  $0.4\text{ ms} \leq t_{WL} \leq 1.6\text{ ms}$

CT Capacitor:  $0.001\text{ }\mu\text{F} \leq C_{CT} < 0.1\text{ }\mu\text{F}$

Typical Performance Curves (Unless otherwise specified,  $T_j = 25\text{ }^\circ\text{C}$ ,  $V_{CC} = 13.5\text{ V}$ ,  $V_{CTL} = 5\text{ V}$ )

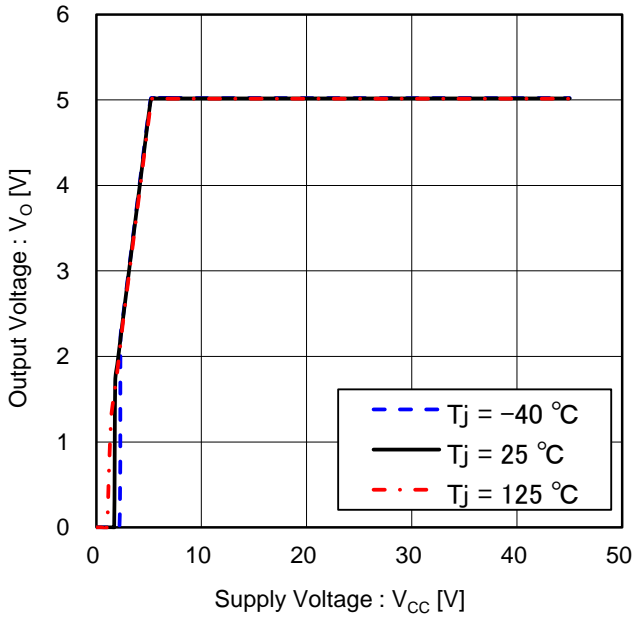

Figure 1. Output Voltage vs Supply Voltage ( $R_L = 25\ \Omega$ )

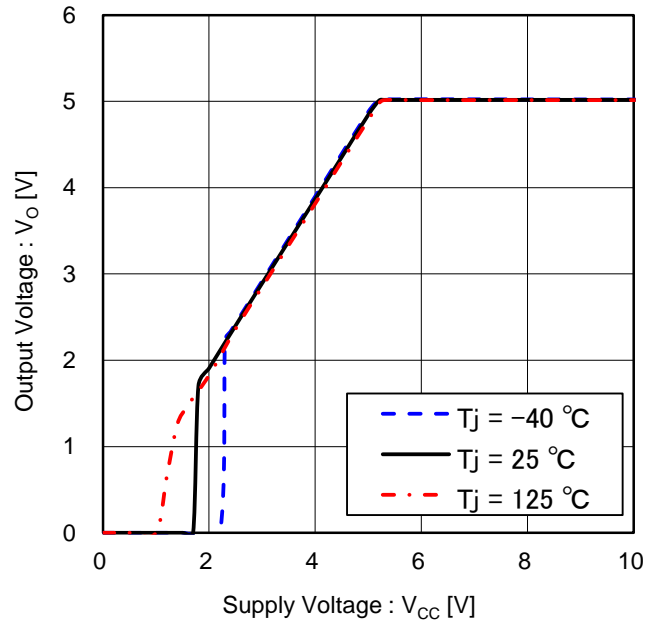

Figure 2. Output Voltage vs Supply Voltage ( $R_L = 25\ \Omega$ )

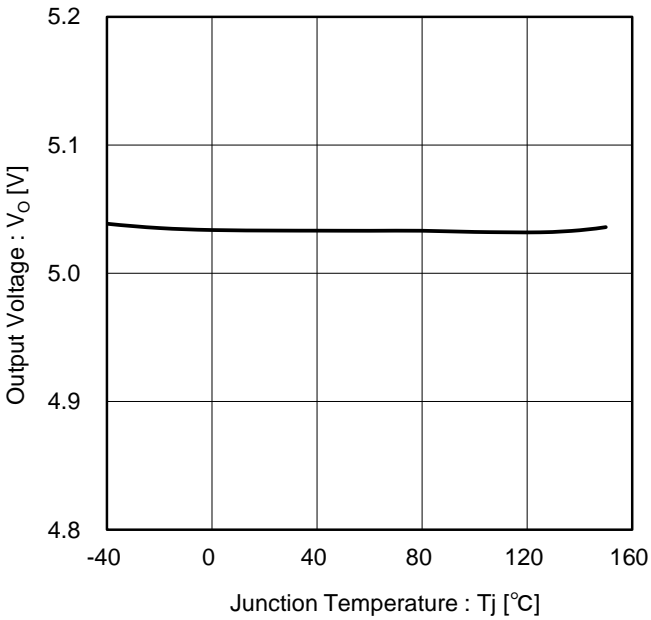

Figure 3. Output Voltage vs Junction Temperature ( $R_L = 1\text{ k}\Omega$ )

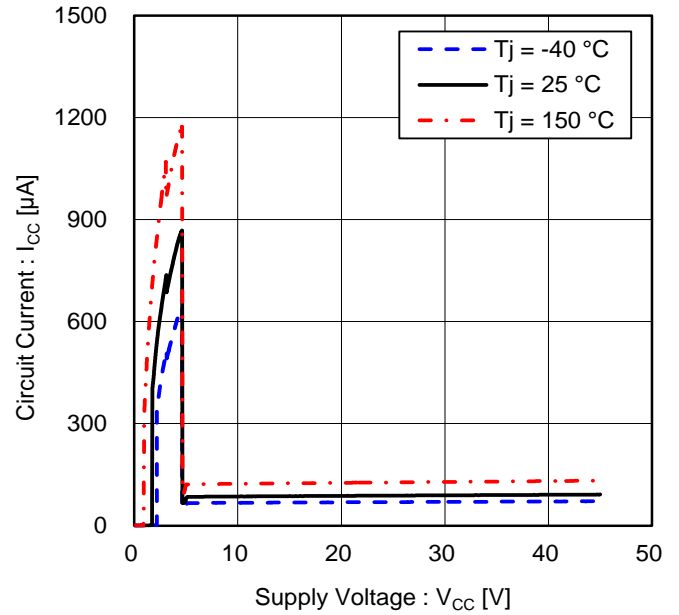

Figure 4. Circuit Current vs Supply Voltage

Typical Performance Curves - continued

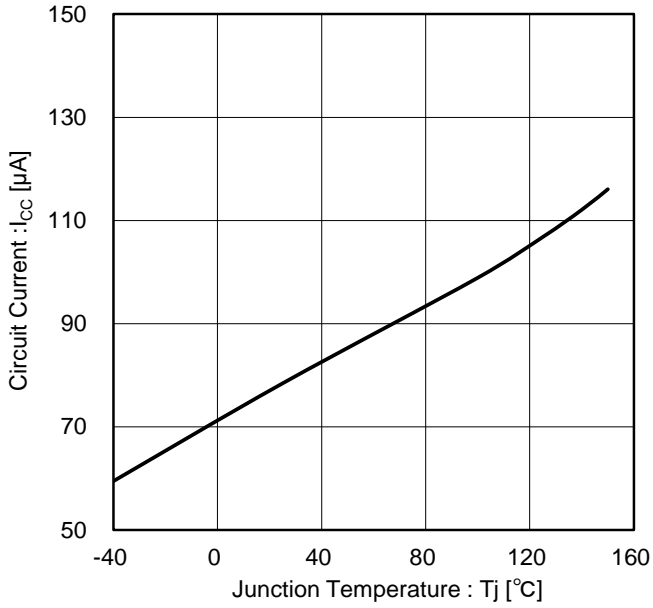

Figure 5. Circuit Current vs Junction Temperature

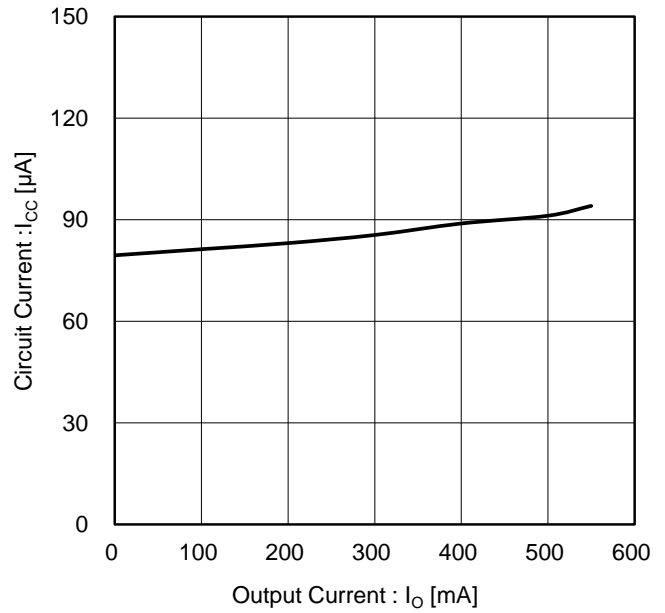

Figure 6. Circuit Current vs Output Current

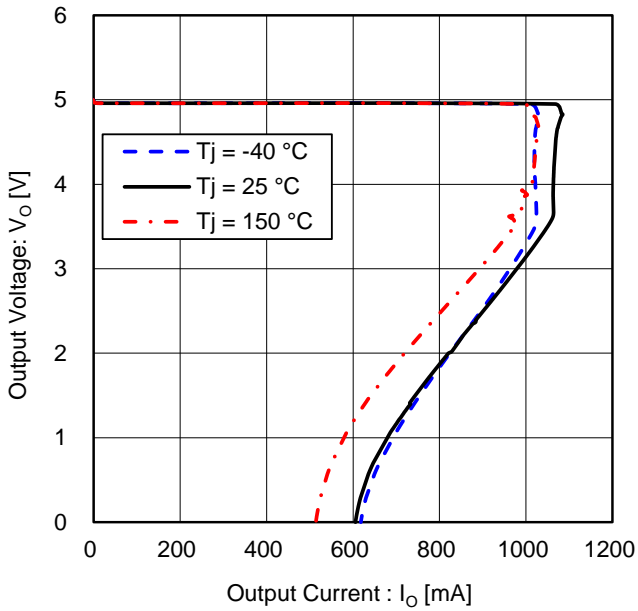

Figure 7. Output Voltage vs. Output Current (Over Current Protection)

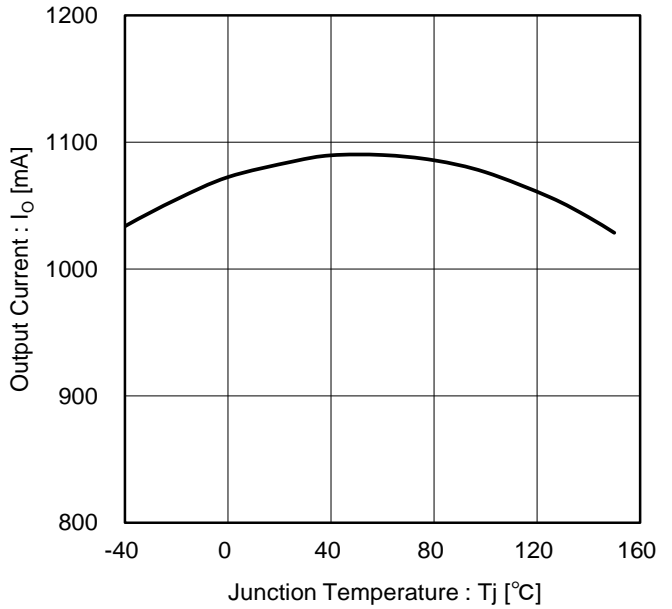

Figure 8. Output Current vs Junction Temperature

Typical Performance Curves - continued

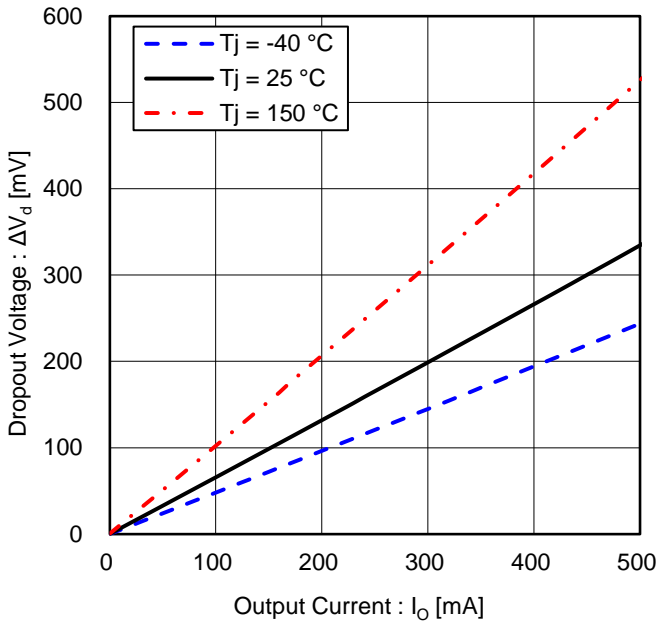

Figure 9. Dropout Voltage vs Output Current  
( $V_{CC} = 4.75\text{ V}$ )

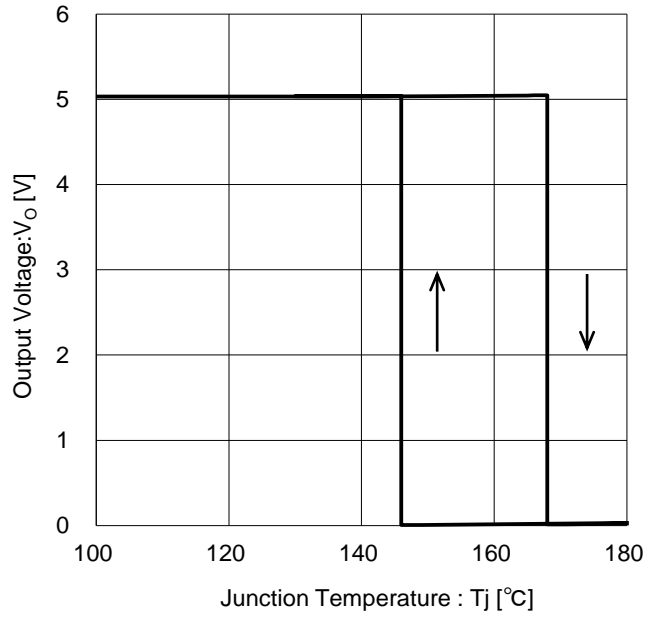

Figure 10. Output Voltage vs Junction Temperature  
(Thermal Shutdown)

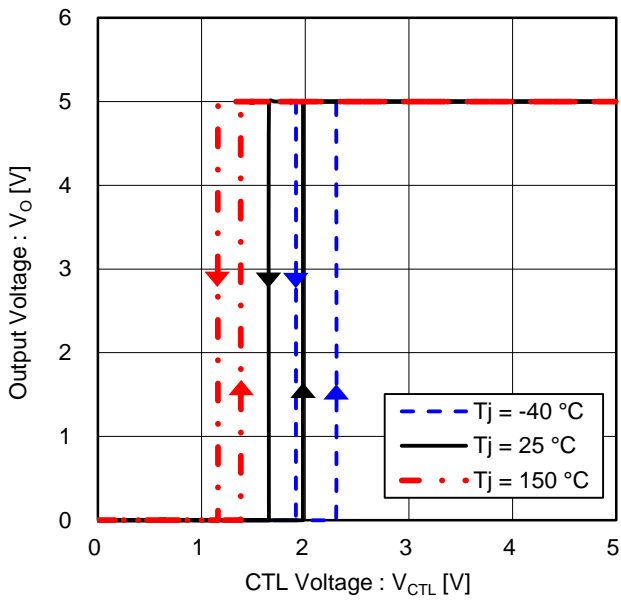

Figure 11. Output Voltage vs CTL Voltage

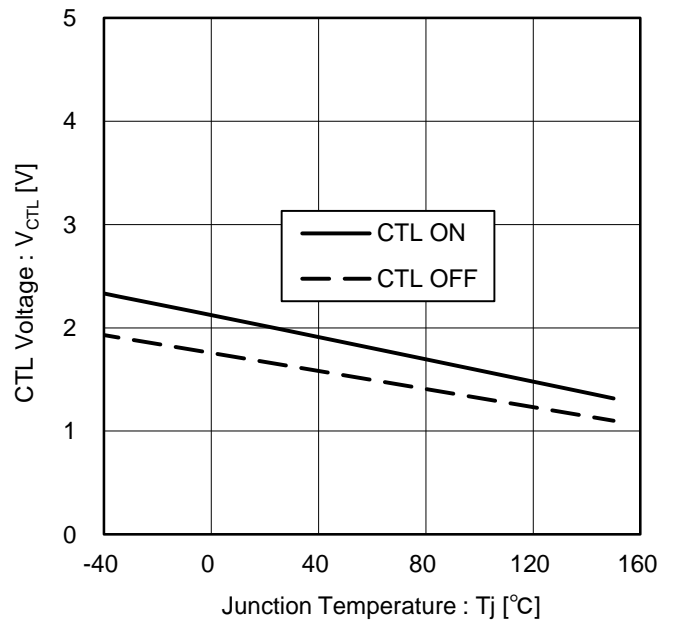

Figure 12. CTL Voltage vs Junction Temperature

Typical Performance Curves - continued

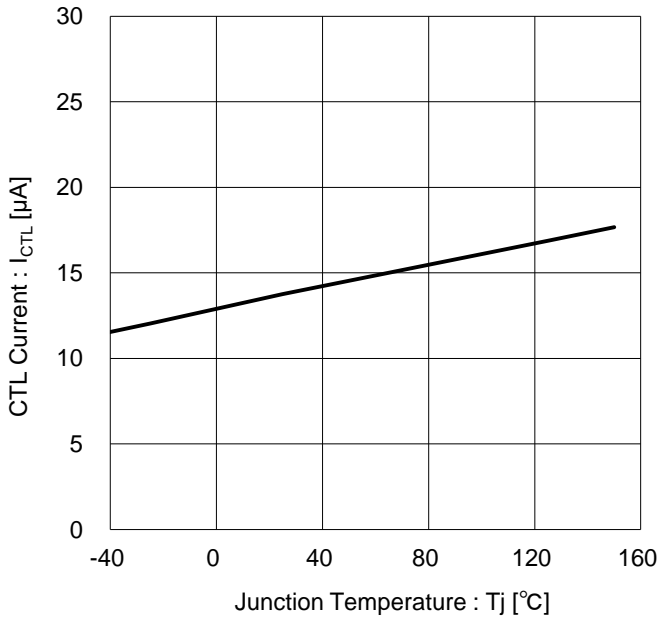

Figure 13. CTL Current vs Junction Temperature

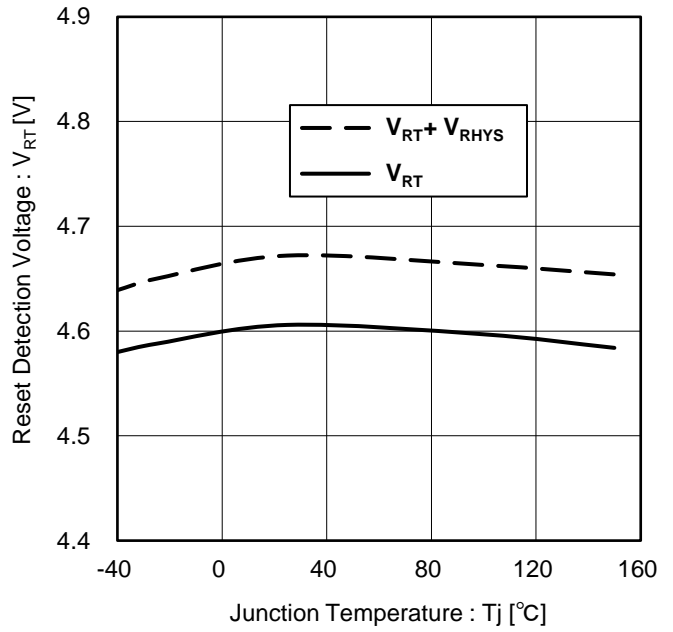

Figure 14. Reset Detection Voltage vs Junction Temperature

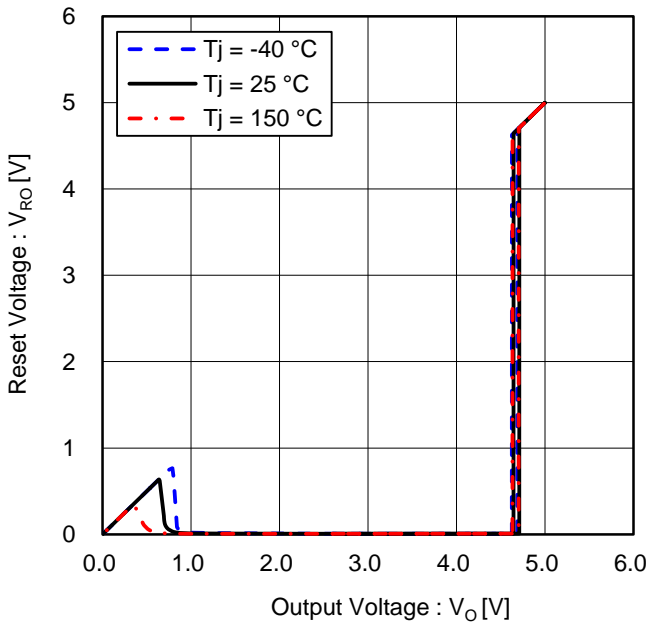

Figure 15. RO Voltage vs Output Voltage

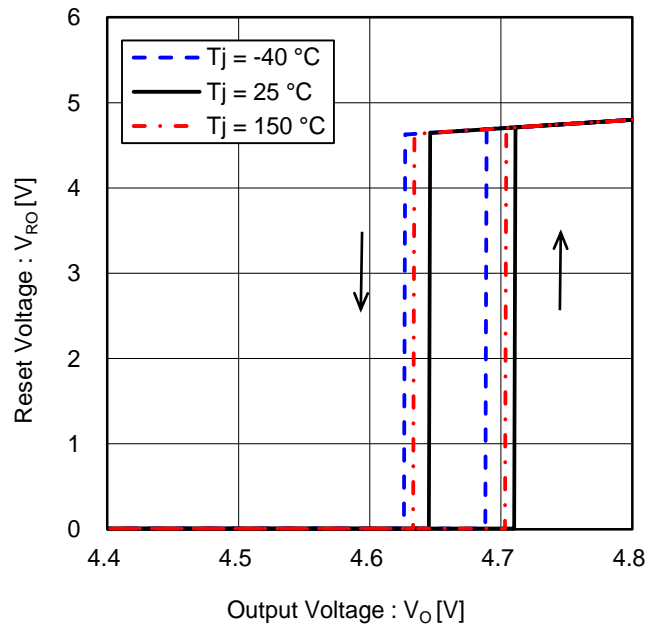

Figure 16. RO Voltage vs Output Voltage

Typical Performance Curves - continued

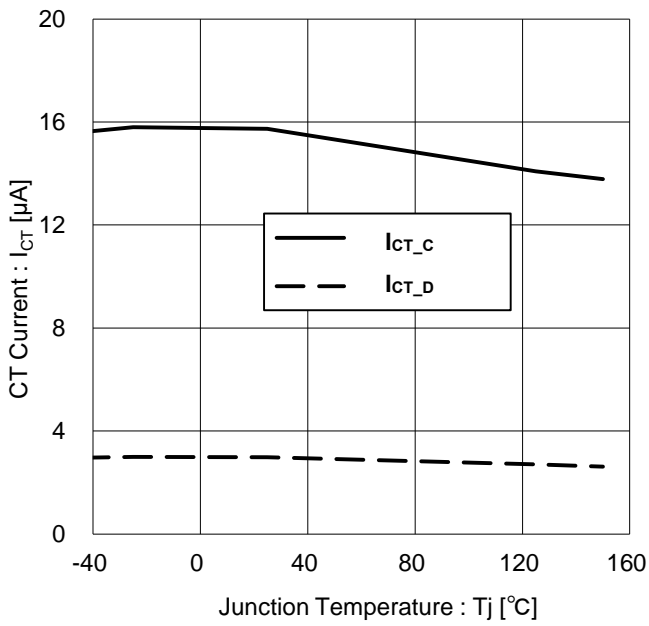

Figure 17. CT Current vs Junction Temperature

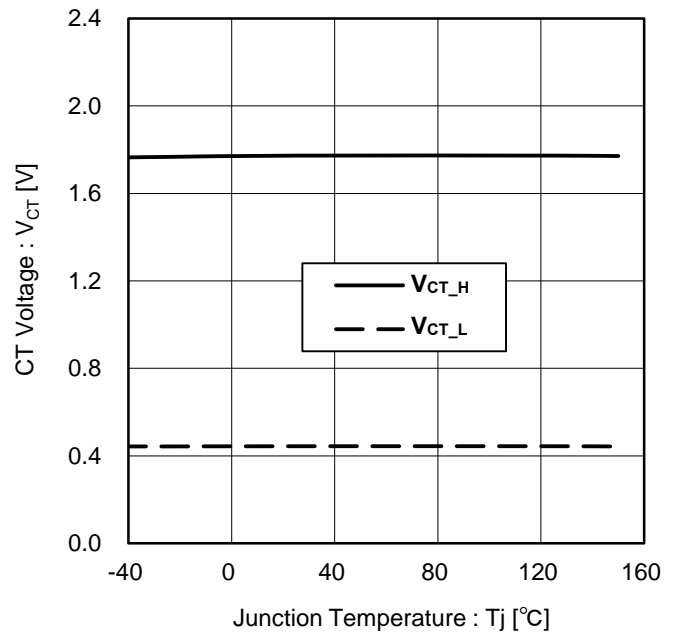

Figure 18. CT Voltage vs Junction Temperature

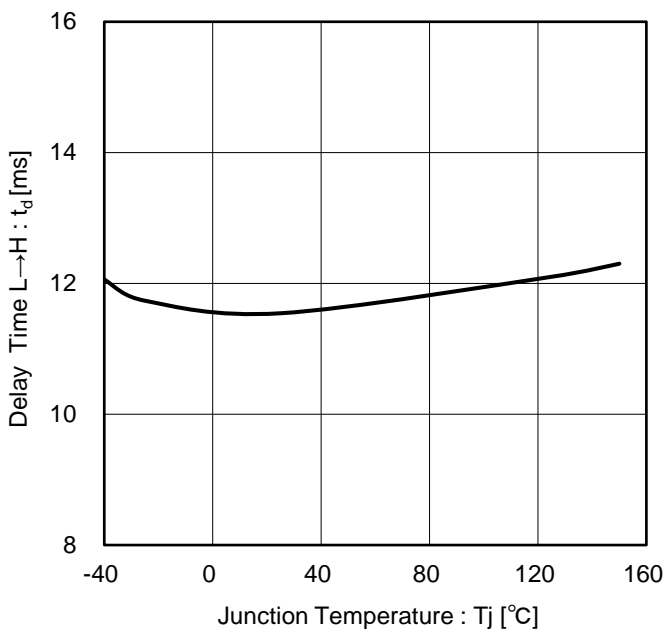

Figure 19. Delay Time L→H vs Junction Temperature  
( $C_{CT} = 0.1 \mu F$ )

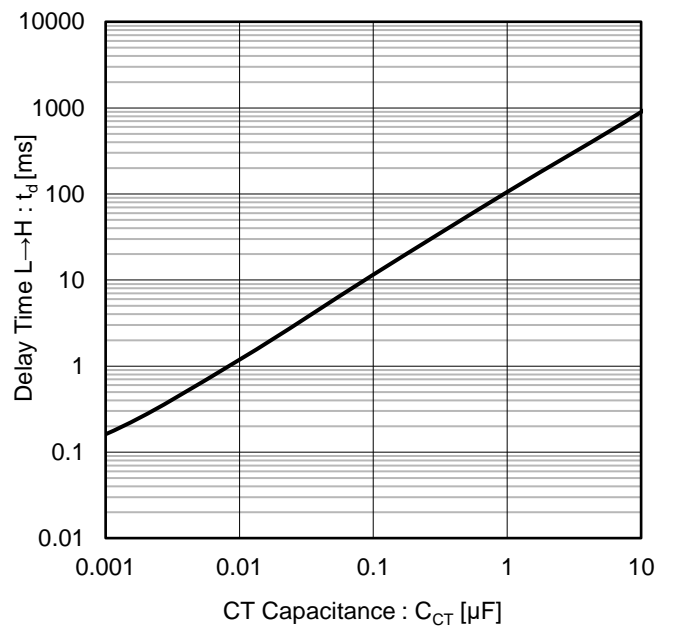

Figure 20. Delay Time L→H vs CT Capacitance

Typical Performance Curves - continued

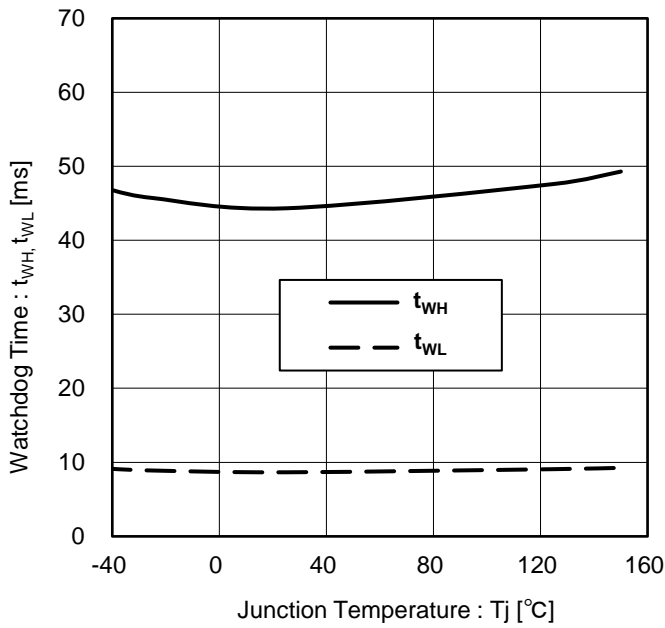

Figure 21. Watchdog Time vs Junction Temperature

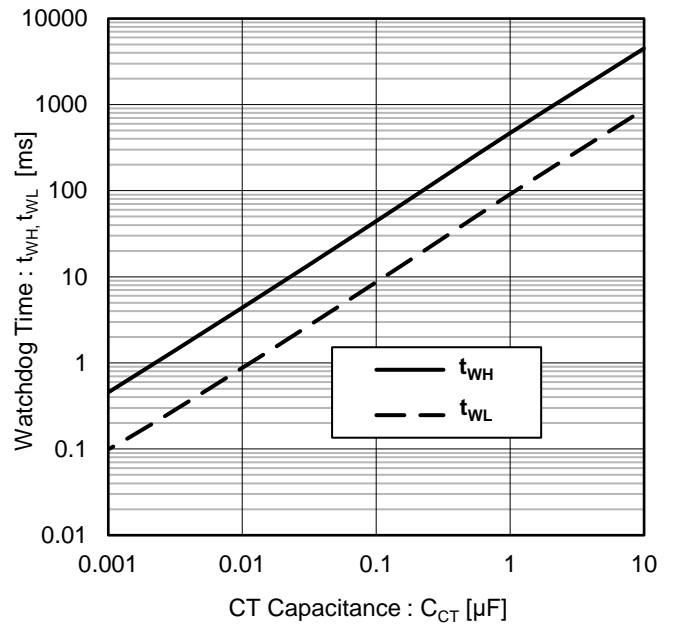
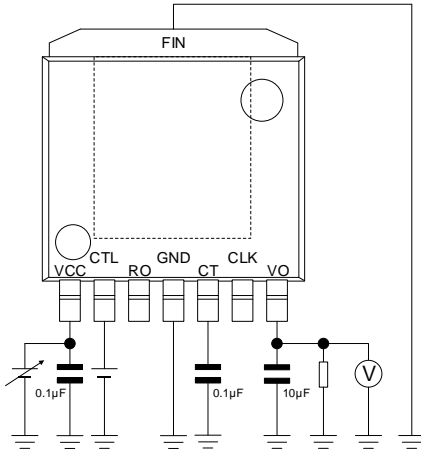
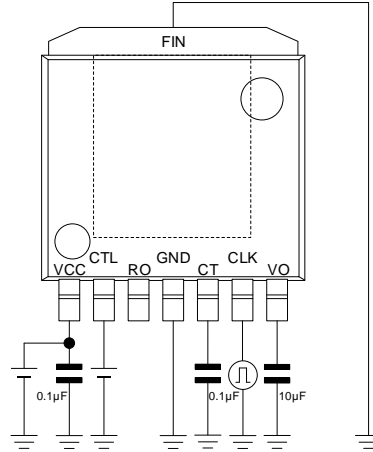

Figure 22. Watchdog Time vs CT Capacitance

Measurement Circuit



Measurement setup for Figure 1,2,3,10.



Measurement setup for Figure 4,5.

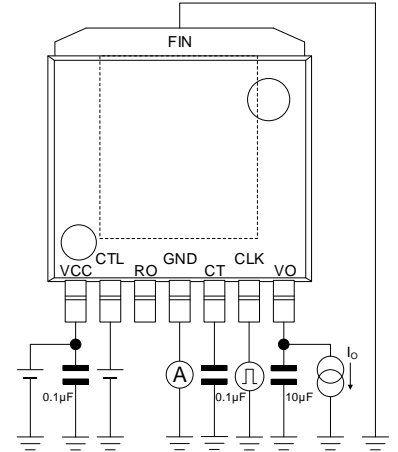

Measurement setup for Figure 6.

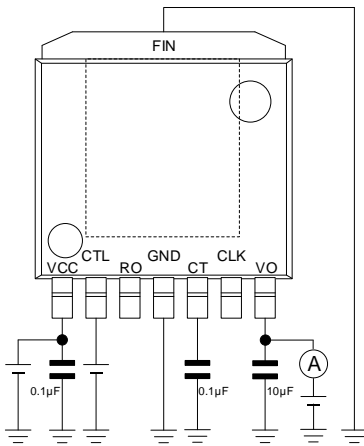

Measurement setup for Figure 7,8.

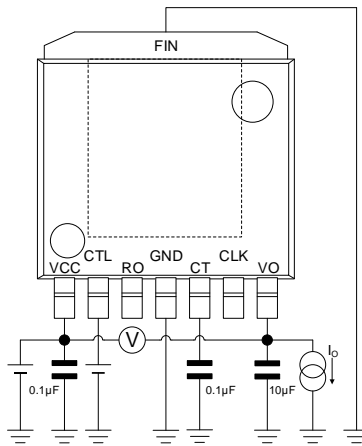

Measurement setup for Figure 9.

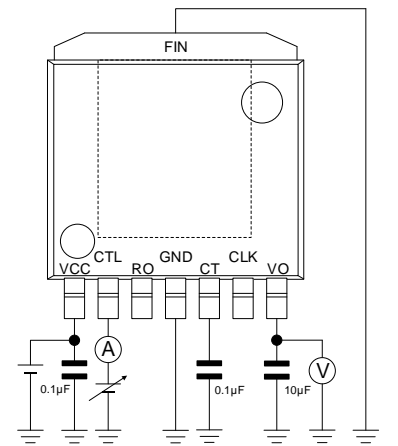

Measurement setup for Figure 11,12,13.

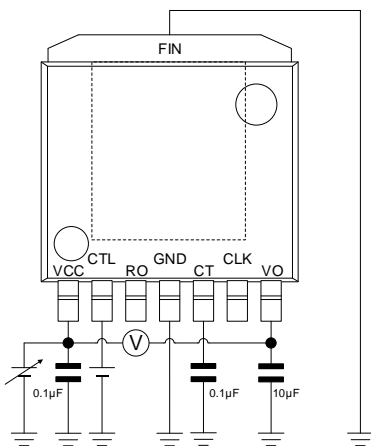

Measurement setup for Figure 14,15,16.

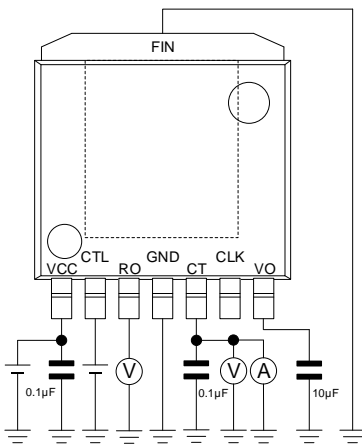

Measurement setup for Figure 17,18.

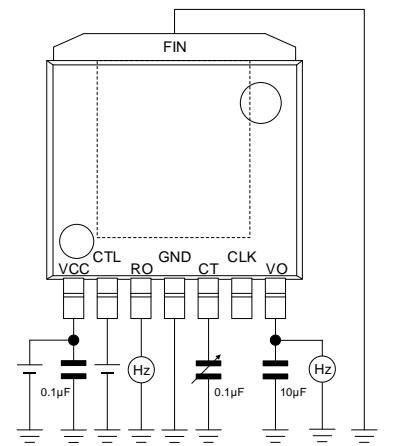

Measurement setup for Figure 19,20,21,22.

Figure 23. Measurement Circuit

Timing Chart

1. When supply voltage  $V_{CC}$  is ON  $\leftrightarrow$  OFF (Not to input CLK voltage  $V_{CLK}$  when output voltage  $V_O = \text{Low}$ )

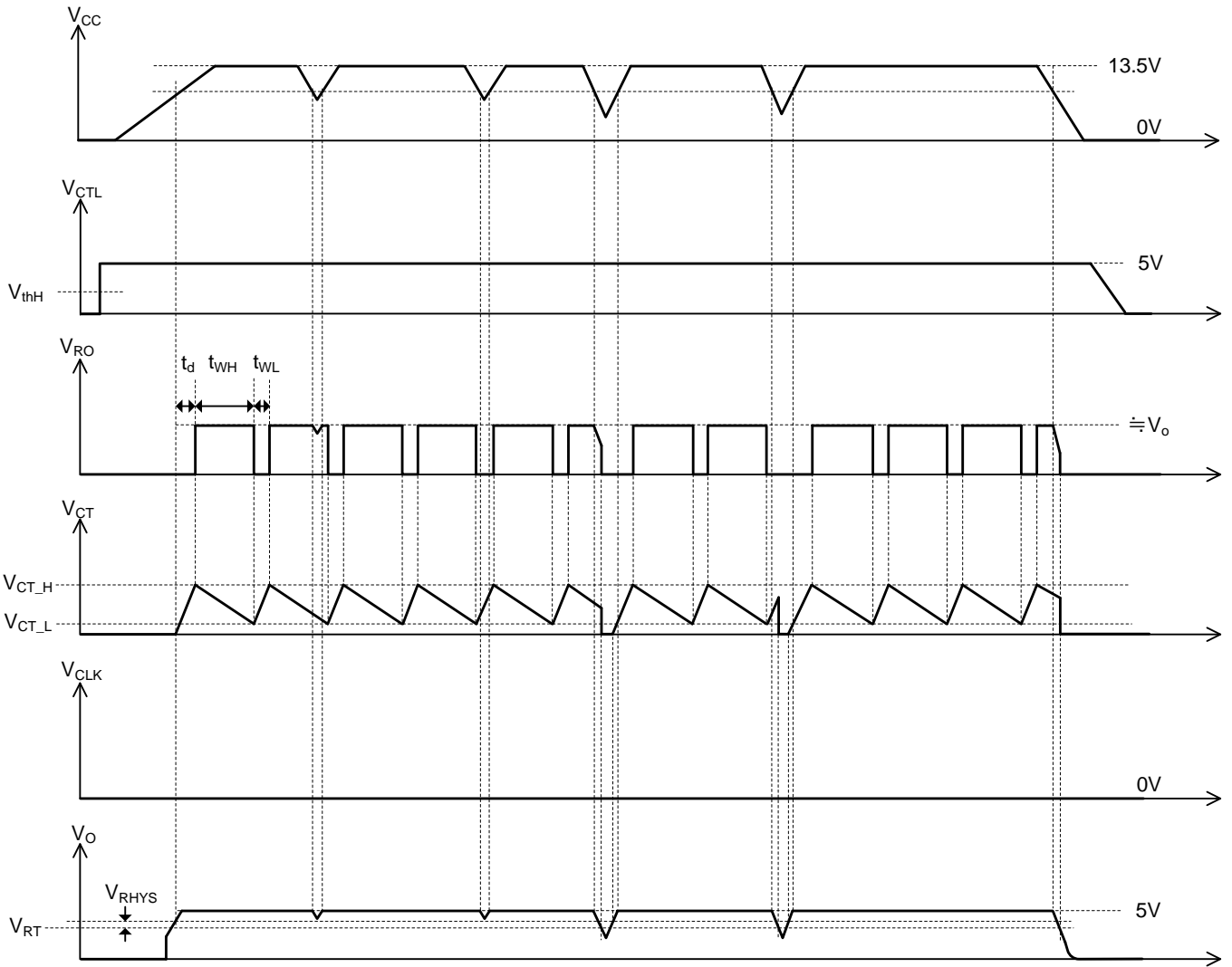

Figure 24. Timing Chart 1

Timing Chart – continued

2. When output control voltage  $V_{CTL}$  is ON  $\leftrightarrow$  OFF (Not to input CLK voltage  $V_{CLK}$  when output voltage  $V_O = \text{Low}$ )

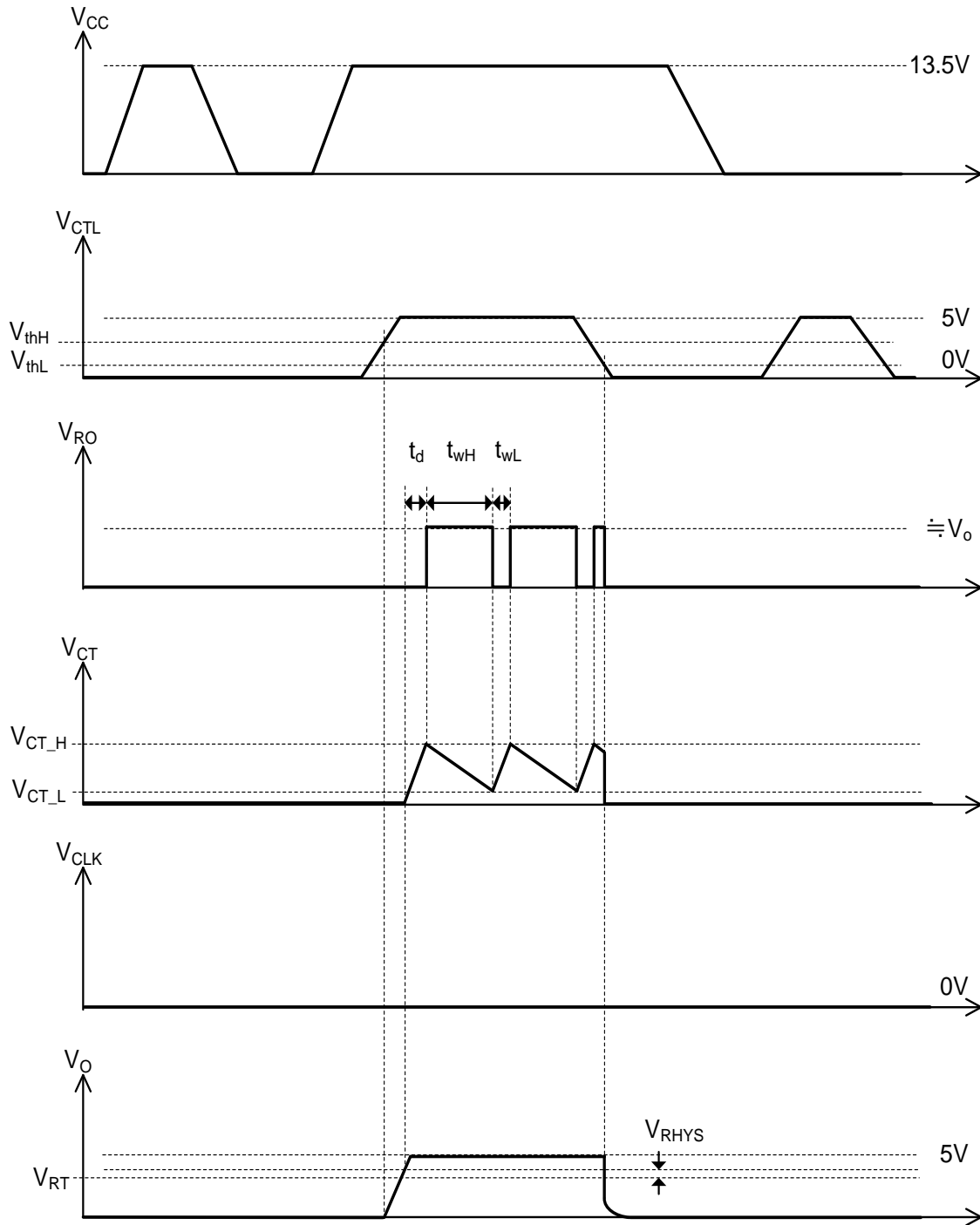

Figure 25. Timing Chart 2

The Delay Time ( $t_d$ ) is estimated roughly by following calculation.

$$t_d[s] \approx \frac{V_{CT\_H}[V] \times C_{CT}[F]}{I_{CT\_C}[A]}$$

Basically, verify the Delay Time ( $t_d$ ) by the ratio of the value at  $C_{CT} = 0.1 \mu\text{F}$  specified in datasheet and the actual  $C_{CT}$  capacitance used to calculate.

Timing Chart – continued

3. When WDT threshold Voltage  $V_{CLK}$  is ON ↔ OFF

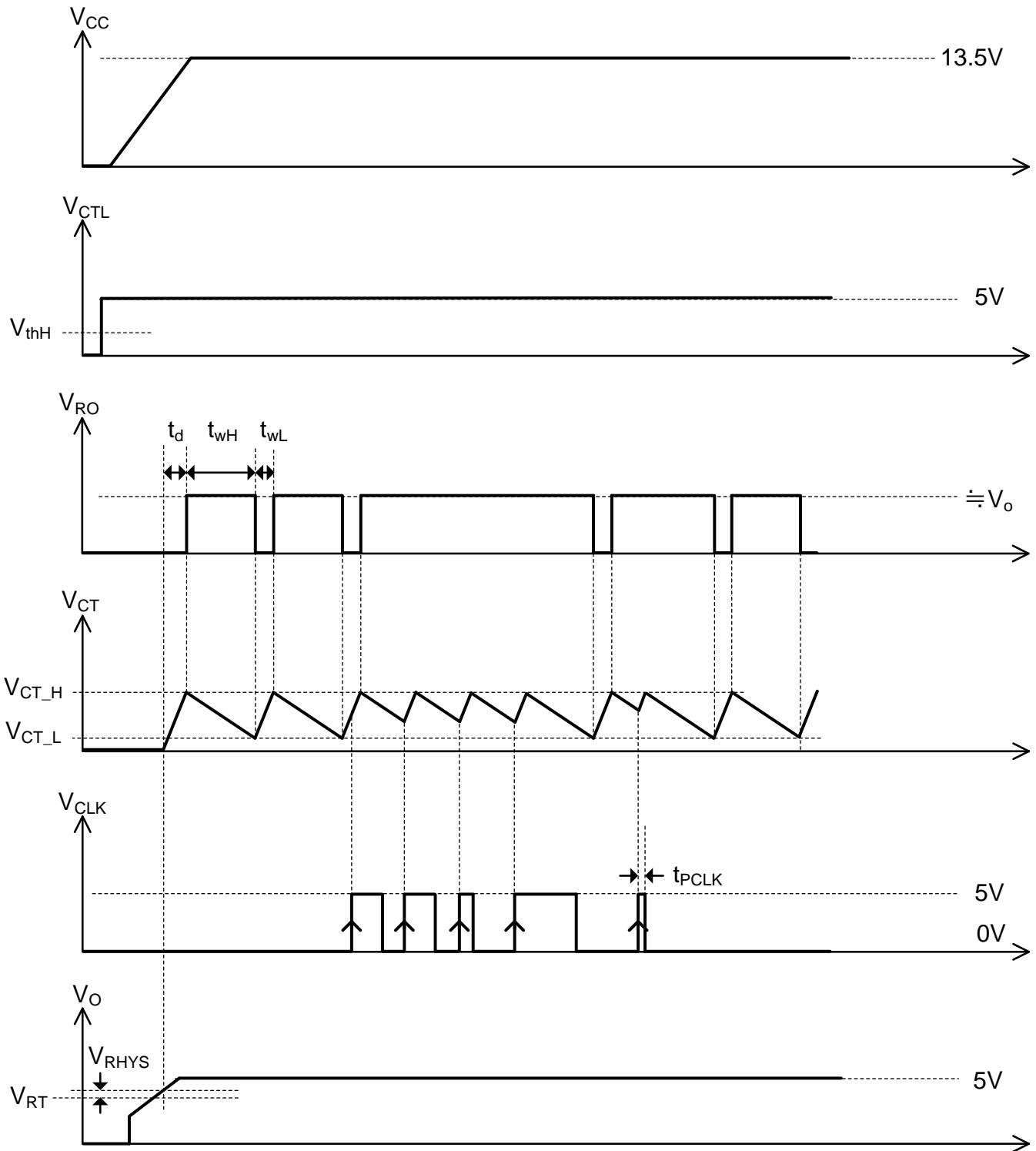

Figure 26. Timing Chart 3

The WDT Monitor Time ( $t_{WH}$ ) and the WDT Reset Time ( $t_{WL}$ ) is estimated roughly by following calculation.

$$t_{WH}[s] \approx \frac{|V_{CT\_H} - V_{CT\_L}|[V] \times C_{CT}[F]}{I_{CT\_D}[A]} \qquad t_{WL}[s] \approx \frac{|V_{CT\_L} - V_{CT\_H}|[V] \times C_{CT}[F]}{I_{CT\_C}[A]}$$

Basically, verify the WDT Monitor Time ( $t_{WH}$ ) and the WDT Reset Time ( $t_{WL}$ ) by the ratio of the value at  $C_{CT} = 0.1 \mu F$  specified in datasheet and the actual  $C_{CT}$  capacitance used to calculate

Disable WDT behavior

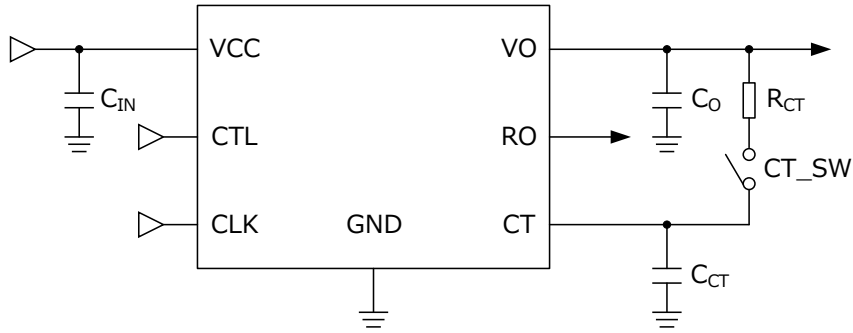

Figure 27. Application Circuit

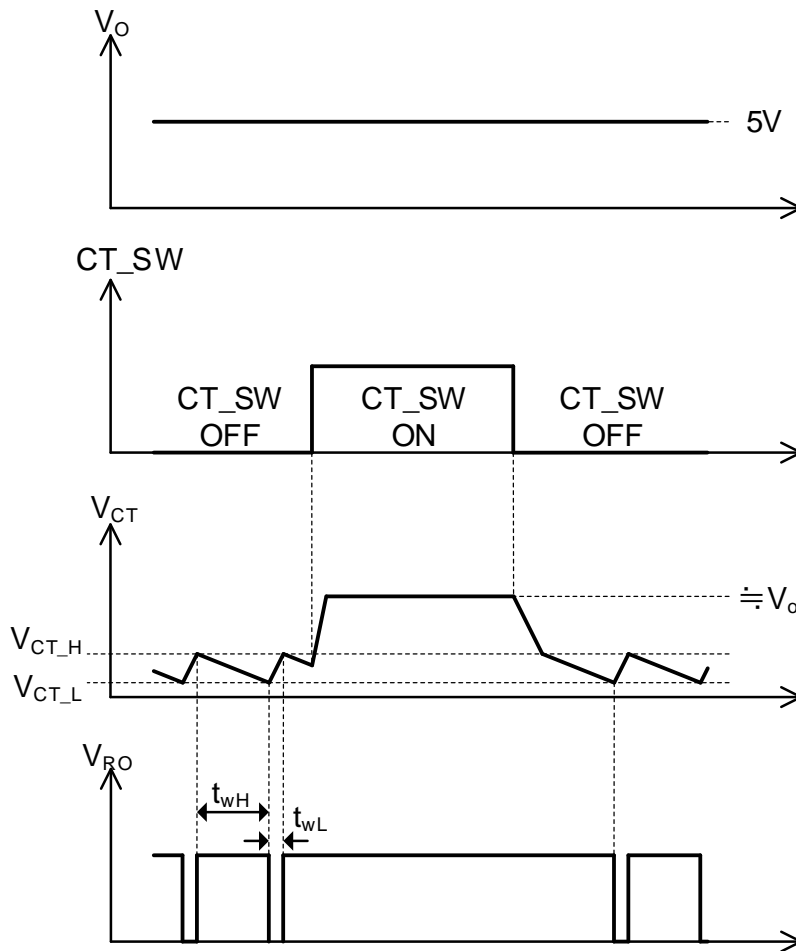

Figure 28. Timing Chart 4

By pulling up the CT pin to the VO pin and keeping CT voltage above  $V_{CT,H}$ , RO switching and WDT behavior are disabled. However, if under voltage reset is detected with the CT pin pulled up to the VO pin, the circuit that rapidly discharges the  $C_{CT}$  electron will operate and current will flow into the CT pin. Therefore, when pulling up the CT pin to the VO pin, the pull up resistor must be required between the VO pin and the CT pin for limiting current. Recommended pull up resistance: 10 k $\Omega$  ~ 200 k $\Omega$

## Selection of Components Externally Connected

- VCC pin capacitor

Insert capacitors with a capacitance of 0.1  $\mu\text{F}$  or higher between the VCC and GND pin. We recommend using ceramic capacitor generally featuring good high frequency characteristic. When selecting a ceramic capacitor, please be consider about temperature and DC-biasing characteristics. Place capacitors closest possible to VCC-GND pin. When input impedance is high, e.g. in case there is distance from battery, line voltage drop needs to be prevented by large capacitor. Choose the capacitance according to the line impedance between the power smoothing circuit and the VCC pin. Selection of the capacitance also depends on the applications. Verify the application and allow sufficient margins in the design. We recommend using a capacitor with excellent voltage and temperature characteristics.

- Output pin capacitor

In order to prevent oscillation, a capacitor needs to be placed between the output pin and GND pin. We recommend using a ceramic capacitor with a capacitance of 6  $\mu\text{F}$  or higher. In selecting the capacitor, ensure that the capacitance of 6  $\mu\text{F}$  or higher is maintained at the intended applied voltage and temperature range. Due to changes in temperature the capacitor's capacitance can fluctuate possibly resulting in oscillation.

In actual applications the stable operating range is influenced by the PCB impedance, input supply impedance and load impedance. Therefore verification of the final operating environment is needed. When selecting a ceramic capacitor, we recommend using X7R or better components with excellent temperature and DC-biasing characteristics and high voltage tolerance.

In case of the transient input voltage and the load current fluctuation, output voltage may fluctuate. In case this fluctuation can be problematic for the application, connect low ESR capacitor (capacitance > 6  $\mu\text{F}$ , ESR < 1  $\Omega$ ) in paralleled to large capacitor with a capacitance of 13  $\mu\text{F}$  or higher and ESR of 5  $\Omega$  or lower. Electrolytic and tantalum capacitors can be used as large capacitor. When selecting an electrolytic capacitor, please consider about increasing ESR and decreasing capacitance at cold temperature.

Place the capacitor closest possible to output pin.

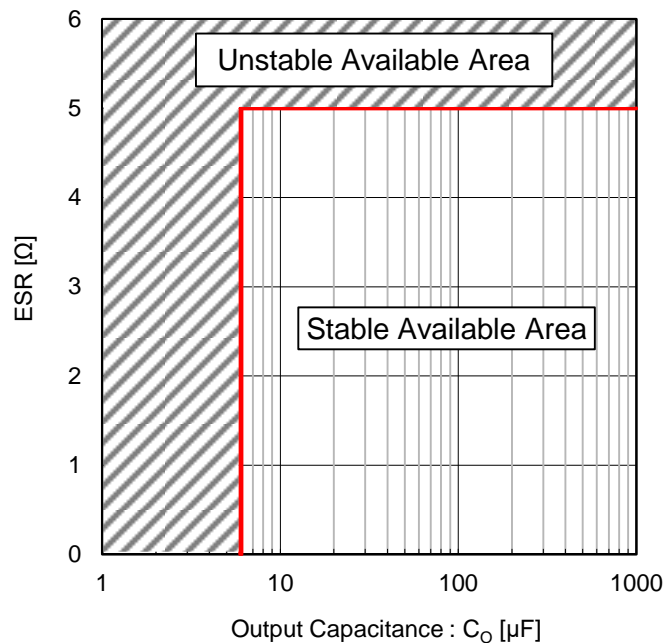

Figure 29. Output Capacitance ESR Available Area  
 $-40\text{ }^{\circ}\text{C} \leq T_j \leq +150\text{ }^{\circ}\text{C}$ ,  $6\text{ V} \leq V_{CC} \leq 45\text{ V}$ ,  $V_{CTL} = 5\text{ V}$ ,  $I_o = 0\text{ mA to } 550\text{ mA}$

**Power Dissipation**

■ HRP7

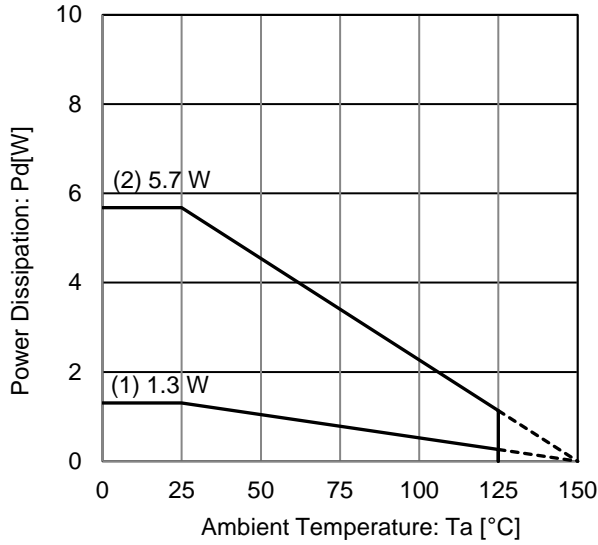

Figure 30. HRP7 Package Data

IC mounted on ROHM standard board based on JEDEC.

- (1) : 1-layer PCB  
 (Copper foil area on the reverse side of PCB: 0 mm x 0 mm)  
 Board material: FR4  
 Board size: 114.3 mm x 76.2 mm x 1.57 mm  
 Mount condition: PCB and exposed pad are soldered.  
 Top copper foil: ROHM recommended footprint + wiring to measure, 2 oz. copper.
- (2) : 4-layer PCB  
 (2 inner layers and Copper foil area on the reverse side of PCB: 74.2 mm x 74.2 mm)  
 Board material: FR4  
 Board size: 114.3 mm x 76.2 mm x 1.60 mm  
 Mount condition: PCB and exposed pad are soldered.  
 Top copper foil: ROHM recommended footprint + wiring to measure, 2 oz. copper.  
 2 inner layers copper foil area of PCB: 74.2 mm x 74.2 mm, 1 oz. copper.  
 Copper foil area on the reverse side of PCB: 74.2 mm x 74.2 mm, 2 oz. copper.  
 Condition (1):  $\theta_{JA} = 96.0 \text{ }^\circ\text{C/W}$ ,  $\Psi_{JT} \text{ (top center)} = 6 \text{ }^\circ\text{C/W}$   
 Condition (2):  $\theta_{JA} = 22.0 \text{ }^\circ\text{C/W}$ ,  $\Psi_{JT} \text{ (top center)} = 2 \text{ }^\circ\text{C/W}$

■ TO263-7

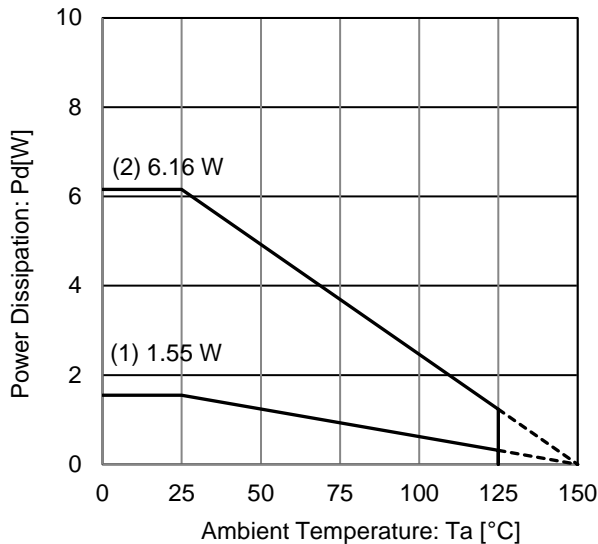

Figure 31. TO263-7 Package Data

IC mounted on ROHM standard board based on JEDEC.

- (1) : 1-layer PCB  
 (Copper foil area on the reverse side of PCB: 0 mm x 0 mm)  
 Board material: FR4  
 Board size: 114.3 mm x 76.2 mm x 1.57 mm  
 Mount condition: PCB and exposed pad are soldered.  
 Top copper foil: ROHM recommended footprint + wiring to measure, 2 oz. copper.
- (2) : 4-layer PCB  
 (2 inner layers and Copper foil area on the reverse side of PCB: 74.2 mm x 74.2 mm)  
 Board material: FR4  
 Board size: 114.3 mm x 76.2 mm x 1.60 mm  
 Mount condition: PCB and exposed pad are soldered.  
 Top copper foil: ROHM recommended footprint + wiring to measure, 2 oz. copper.  
 2 inner layers copper foil area of PCB: 74.2 mm x 74.2 mm, 1 oz. copper.  
 Copper foil area on the reverse side of PCB: 74.2 mm x 74.2 mm, 2 oz. copper.  
 Condition (1):  $\theta_{JA} = 80.7 \text{ }^\circ\text{C/W}$ ,  $\Psi_{JT} \text{ (top center)} = 8 \text{ }^\circ\text{C/W}$   
 Condition (2):  $\theta_{JA} = 20.3 \text{ }^\circ\text{C/W}$ ,  $\Psi_{JT} \text{ (top center)} = 2 \text{ }^\circ\text{C/W}$

**Power Dissipation – continued**

■ HTSOP-J8

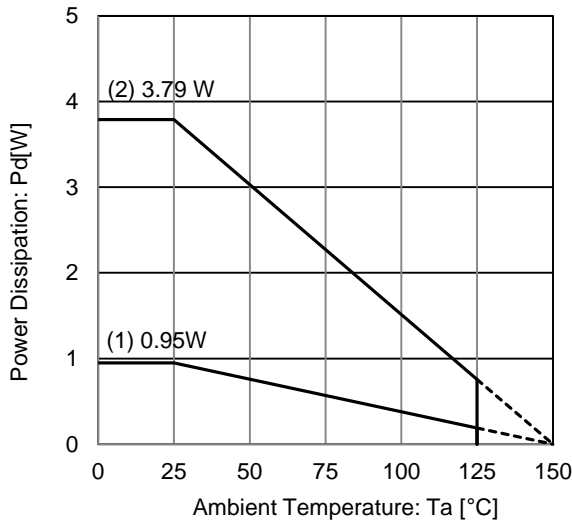

Figure 32. HTSOP-J8 Package Data

IC mounted on ROHM standard board based on JEDEC.

- (1) : 1-layer PCB  
 (Copper foil area on the reverse side of PCB: 0 mm x 0 mm)  
 Board material: FR4  
 Board size: 114.3 mm x 76.2 mm x 1.57 mm  
 Mount condition: PCB and exposed pad are soldered.  
 Top copper foil: ROHM recommended footprint + wiring to measure, 2 oz. copper.
  - (2) : 4-layer PCB  
 (2 inner layers and Copper foil area on the reverse side of PCB: 74.2 mm x 74.2 mm)  
 Board material: FR4  
 Board size: 114.3 mm x 76.2 mm x 1.60 mm  
 Mount condition: PCB and exposed pad are soldered.  
 Top copper foil: ROHM recommended footprint + wiring to measure, 2 oz. copper.  
 2 inner layers copper foil area of PCB: 74.2 mm x 74.2 mm, 1 oz. copper.  
 Copper foil area on the reverse side of PCB: 74.2 mm x 74.2 mm, 2 oz. copper.
- Condition (1):  $\theta_{JA} = 131.7 \text{ }^\circ\text{C/W}$ ,  $\Psi_{JT} \text{ (top center)} = 12 \text{ }^\circ\text{C/W}$   
 Condition (2):  $\theta_{JA} = 33 \text{ }^\circ\text{C/W}$ ,  $\Psi_{JT} \text{ (top center)} = 5 \text{ }^\circ\text{C/W}$

## Thermal Design

This product exposes a frame on the back side of the package for thermal efficiency improvement.

Within this IC, the power consumption is decided by the dropout voltage condition, the load current and the circuit current. Refer to power dissipation curves illustrated in Figure 30, 31 and 32 when using the IC in an environment of  $T_a \geq 25\text{ }^\circ\text{C}$ . Even if the ambient temperature  $T_a$  is at  $25\text{ }^\circ\text{C}$ , depending on the input voltage and the load current, chip junction temperature can be very high. Consider the design to be  $T_j \leq T_{jmax} = 150\text{ }^\circ\text{C}$  in all possible operating temperature range.

Should by any condition the maximum junction temperature  $T_{jmax} = 150\text{ }^\circ\text{C}$  rating be exceeded by the temperature increase of the chip, it may result in deterioration of the properties of the chip. The thermal impedance in this specification is based on recommended PCB and measurement condition by JEDEC standard. Verify the application and allow sufficient margins in the thermal design by the following method is used to calculate the junction temperature  $T_j$ .

$T_j$  can be calculated by either of the two following methods.

1. The following method is used to calculate the junction temperature  $T_j$ .

$$T_j = T_a + P_C \times \theta_{JA}$$

$T_j$	: Junction Temperature
$T_a$	: Ambient Temperature
$P_C$	: Power Consumption
$\theta_{JA}$	: Thermal Impedance (Junction to Ambient)

2. The following method is also used to calculate the junction temperature  $T_j$ .

$$T_j = T_T + P_C \times \Psi_{JT}$$

$T_j$	: Junction Temperature
$T_T$	: Top Center of Case's (mold) Temperature
$P_C$	: Power Consumption
$\Psi_{JT}$	: Thermal Impedance (Junction to Top Center of Case)

The following method is used to calculate the power consumption  $P_C$  (W).

$$P_C = (V_{CC} - V_o) \times I_o + V_{CC} \times I_{CC}$$

$P_C$	: Power Consumption
$V_{CC}$	: Supply Voltage
$V_o$	: Output Voltage
$I_o$	: Load Current
$I_{CC}$	: Circuit Current

### • Calculation Example

If  $V_{CC} = 13.5\text{ V}$ ,  $V_o = 5.0\text{ V}$ ,  $I_o = 200\text{ mA}$ ,  $I_{CC} = 85\text{ }\mu\text{A}$ , the power consumption  $P_C$  can be calculated as follows:

$$\begin{aligned} P_C &= (V_{CC} - V_o) \times I_o + V_{CC} \times I_{CC} \\ &= (13.5\text{ V} - 5.0\text{ V}) \times 200\text{ mA} + 13.5\text{ V} \times 85\text{ }\mu\text{A} \\ &= 1.7\text{ W} \end{aligned}$$

At the ambient temperature  $T_a = 85\text{ }^\circ\text{C}$ , the thermal impedance (Junction to Ambient)  $\theta_{JA} = 22.0\text{ }^\circ\text{C/W}$  (4-layer PCB),

$$\begin{aligned} T_j &= T_a + P_C \times \theta_{JA} \\ &= 85\text{ }^\circ\text{C} + 1.7\text{ W} \times 22.0\text{ }^\circ\text{C/W} \\ &= 122.4\text{ }^\circ\text{C} \end{aligned}$$

When operating the IC, the top center of case's (mold) temperature  $T_T = 100\text{ }^\circ\text{C}$ ,  $\Psi_{JT} = 6\text{ }^\circ\text{C/W}$  (1-layer PCB),

$$\begin{aligned} T_j &= T_T + P_C \times \Psi_{JT} \\ &= 100\text{ }^\circ\text{C} + 1.7\text{ W} \times 6\text{ }^\circ\text{C/W} \\ &= 110.2\text{ }^\circ\text{C} \end{aligned}$$

For optimum thermal performance, it is recommended to expand the copper foil area of the board, increasing the layer and thermal via between thermal land pad.

Application Examples

- Applying positive surge to the VCC

If the possibility exists that surges higher than 45 V will be applied to the VCC, a Zener Diode should be placed between the VCC and GND as shown in the figure below.

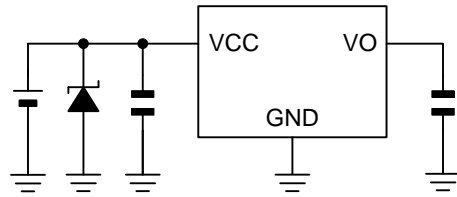

- Applying negative surge to the VCC

If the possibility exists that negative surges lower than the GND are applied to the VCC, a Schottky Diode should be placed between the VCC and GND as shown in the figure below.

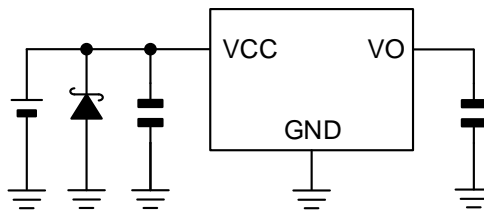

- Implementing a Protection Diode

If the possibility exists that a large inductive load is connected to the output pin resulting in back-EMF at time of startup and shutdown, a protection diode should be placed as shown in the figure below.

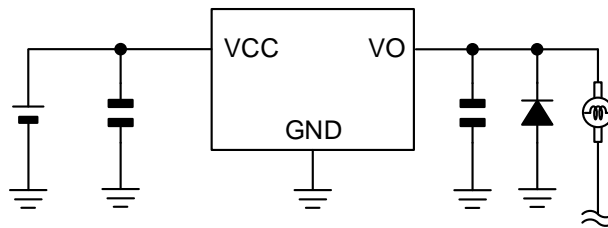

- Reverse Polarity Diode

In some applications, the VCC and the VO potential might be reversed, possibly resulting in circuit internal damage or damage to the elements. For example, the accumulated charge in the output pin capacitor flowing backward from the VO to the VCC when the VCC shorts to the GND. In order to minimize the damage in such case, use a capacitor with a capacitance less than 1000  $\mu$ F. Also by inserting a reverse polarity diode in series to the VCC, it can prevent reverse current from reverse battery connection or the case. When the point A is short-circuited GND, if there may be any possible case point B is short-circuited to GND, we also recommend using a bypass diode between the VCC and the VO.

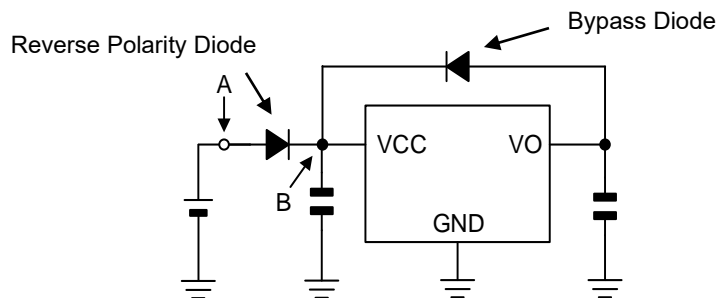

I/O Equivalence Circuits (Note 1)

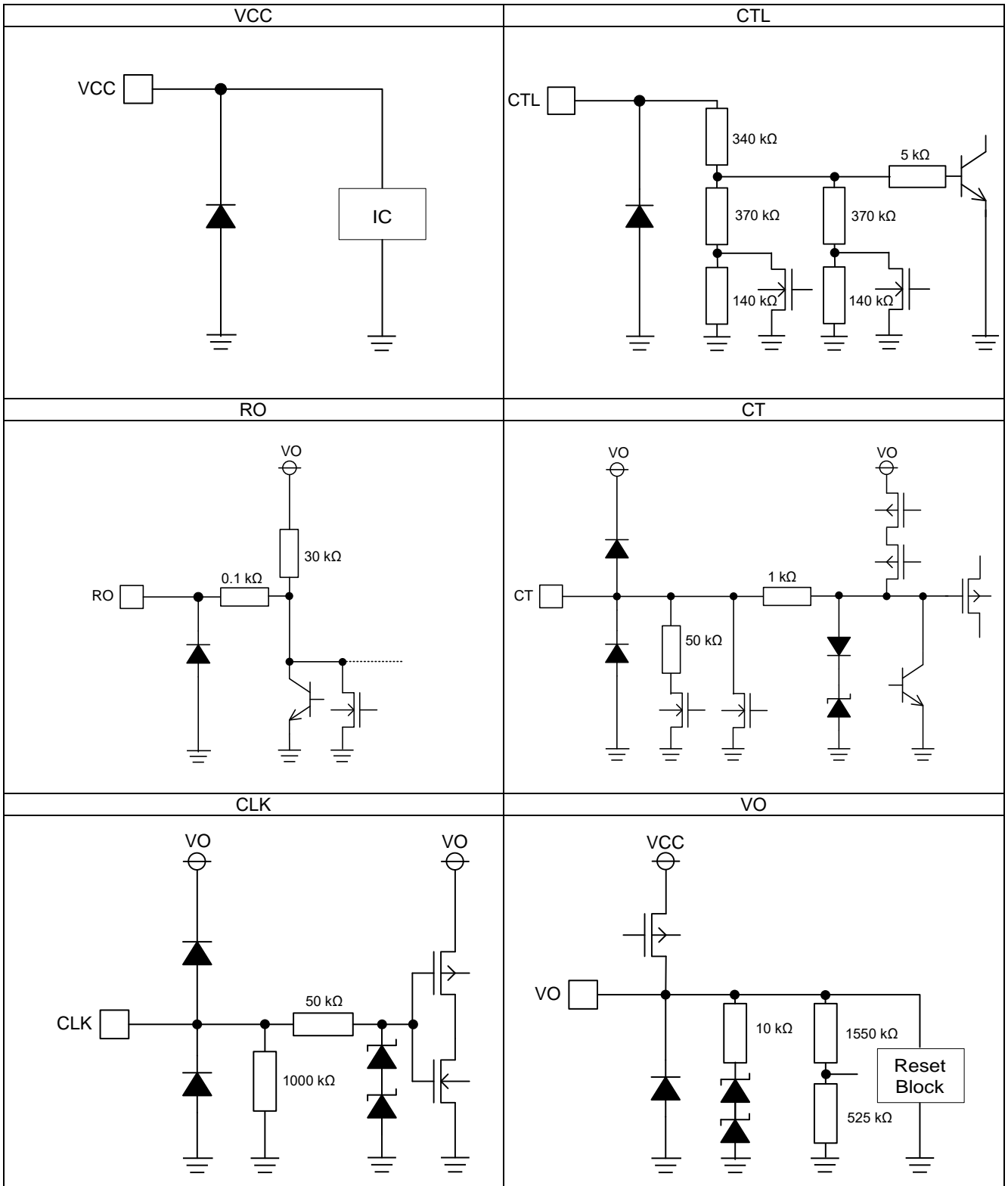

(Note 1) Resistance value is Typical.

## Operational Notes

### 1. Reverse Connection of Power Supply

Connecting the power supply in reverse polarity can damage the IC. Take precautions against reverse polarity when connecting the power supply, such as mounting an external diode between the power supply and the IC's power supply terminals.

### 2. Power Supply Lines

Design the PCB layout pattern to provide low impedance supply lines. Separate the ground and supply lines of the digital and analog blocks to prevent noise in the ground and supply lines of the digital block from affecting the analog block. Furthermore, connect a capacitor to ground at all power supply pins. Consider the effect of temperature and aging on the capacitance value when using electrolytic capacitors.

### 3. Ground Voltage

Ensure that no pins are at a voltage below that of the ground pin at any time, even during transient condition.

### 4. Ground Wiring Pattern

When using both small-signal and large-current ground traces, the two ground traces should be routed separately but connected to a single ground at the reference point of the application board to avoid fluctuations in the small-signal ground caused by large currents. Also ensure that the ground traces of external components do not cause variations on the ground voltage. The ground lines must be as short and thick as possible to reduce line impedance.

### 5. Thermal Consideration

The power dissipation under actual operating conditions should be taken into consideration and a sufficient margin should be allowed for in the thermal design. On the reverse side of the package this product has an exposed heat pad for improving the heat dissipation. Use both the front and reverse side of the PCB to increase the heat dissipation pattern as far as possible. The amount of heat generated depends on the voltage difference across the input and output, load current, and bias current. Therefore, when actually using the chip, ensure that the generated heat does not exceed the Pd rating.

Should by any condition the maximum junction temperature  $T_{jmax} = 150\text{ }^{\circ}\text{C}$  rating be exceeded by the temperature increase of the chip, it may result in deterioration of the properties of the chip. The thermal impedance in this specification is based on recommended PCB and measurement condition by JEDEC standard. Verify the application and allow sufficient margins in the thermal design.

### 6. Recommended Operating Conditions

These conditions represent a range within which the expected characteristics of the IC can be approximately obtained. The electrical characteristics are guaranteed under the conditions of each parameter.

### 7. Rush Current

When power is first supplied to the IC, it is possible that the internal logic may be unstable and inrush current may flow instantaneously due to the internal powering sequence and delays, especially if the IC has more than one power supply. Therefore, give special consideration to power coupling capacitance, power wiring, width of ground wiring, and routing of connections.

### 8. Testing on Application Boards

When testing the IC on an application board, connecting a capacitor directly to a low-impedance output pin may subject the IC to stress. Always discharge capacitors completely after each process or step. The IC's power supply should always be turned off completely before connecting or removing it from the test setup during the inspection process. To prevent damage from static discharge, ground the IC during assembly and use similar precautions during transport and storage.

### 9. Inter-pin Short and Mounting Errors

Ensure that the direction and position are correct when mounting the IC on the PCB. Incorrect mounting may result in damaging the IC. Avoid nearby pins being shorted to each other especially to ground, power supply and output pin. Inter-pin shorts could be due to many reasons such as metal particles, water droplets (in very humid environment) and unintentional solder bridge deposited in between pins during assembly to name a few.

## Operational Notes – continued

**10. Unused Input Terminals**

Input terminals of an IC are often connected to the gate of a MOS transistor. The gate has extremely high impedance and extremely low capacitance. If left unconnected, the electric field from the outside can easily charge it. The small charge acquired in this way is enough to produce a significant effect on the conduction through the transistor and cause unexpected operation of the IC. So unless otherwise specified, unused input terminals should be connected to the power supply or ground line.

**11. Regarding the Input Pin of the IC**

This monolithic IC contains P+ isolation and P substrate layers between adjacent elements in order to keep them isolated. P/N junctions are formed at the intersection of these P layers with the N layers of other elements to create a variety of parasitic elements.

For example, in case a resistor and a transistor are connected to the pins as shown in the figure below then:

- The P/N junction functions as a parasitic diode when the GND > pin A for the resistor, or the GND > pin B for the transistor.

- Also, when the GND > pin B for the transistor (NPN), the parasitic diode described above combines with the N layer of the other adjacent elements to operate as a parasitic NPN transistor.

Parasitic diodes inevitably occur in the structure of the IC. Their operation can result in mutual interference between circuits and can cause malfunctions and, in turn, physical damage to or destruction of the chip. Therefore do not employ any method in which parasitic diodes can operate such as applying a voltage to an input pin that is lower than the (P substrate) GND.

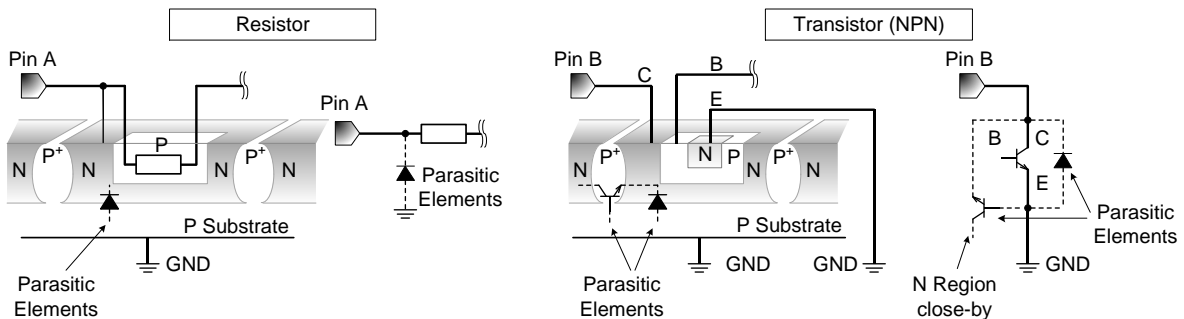
**12. Ceramic Capacitor**

When using a ceramic capacitor, determine the dielectric constant considering the change of capacitance with temperature and the decrease in nominal capacitance due to DC bias and others.

**13. Thermal Shutdown Circuit (TSD)**

This IC incorporates an integrated thermal shutdown circuit to prevent heat damage to the IC. Normal operation should be within the power dissipation rating, if however the rating is exceeded for a continued period, the junction temperature ( $T_j$ ) will rise and the TSD circuit will be activated and turn all output pins OFF. After the  $T_j$  falls below the TSD threshold the circuits are automatically restored to normal operation.

Note that the TSD circuit operates in a situation that exceeds the absolute maximum ratings and therefore, under no circumstances, should the TSD circuit be used in a set design or for any purpose other than protecting the IC from heat damage.

**14. Over Current Protection Circuit (OCP)**

This IC incorporates an integrated overcurrent protection circuit that is activated when the load is shorted. This protection circuit is effective in preventing damage due to sudden and unexpected incidents. However, the IC should not be used in applications characterized by continuous operation or transitioning of the protection circuit.

**15. Functional Safety**

“ISO 26262 Process Compliant to Support ASIL-\*\*\*”

A product that has been developed based on an ISO 26262 design process compliant to the ASIL level described in the datasheet.

“Safety Mechanism is Implemented to Support Functional Safety (ASIL-\*\*\*)”

A product that has implemented safety mechanism to meet ASIL level requirements described in the datasheet.

“Functional Safety Supportive Automotive Products”

A product that has been developed for automotive use and is capable of supporting safety analysis with regard to the functional safety.

Note: “ASIL-\*\*\*” is stands for the ratings of “ASIL-A”, “-B”, “-C” or “-D” specified by each product’s datasheet.

Ordering Information

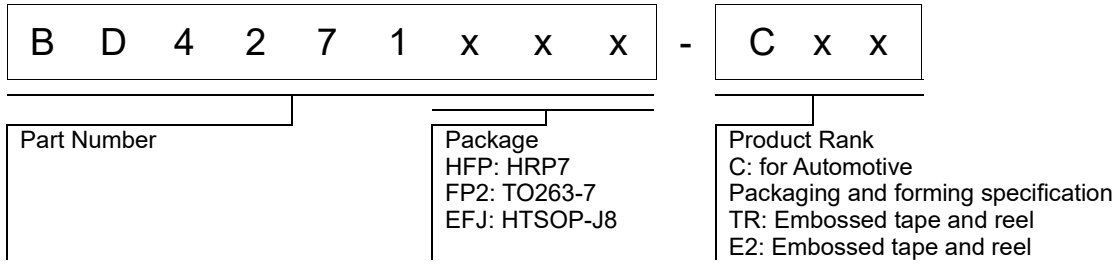

Marking Diagram

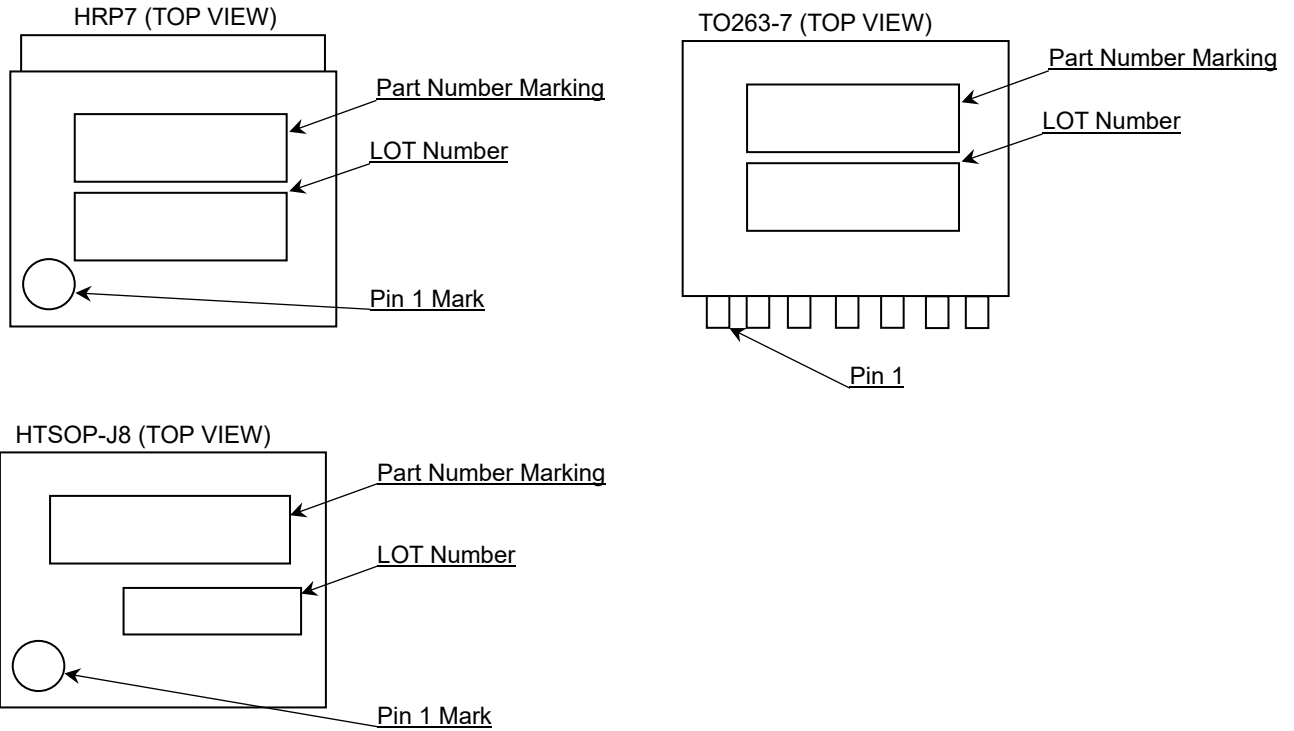

Part Number Marking	Package	Orderable Part Number
BD4271	HRP7	BD4271HFP-CTR
	TO263-7	BD4271FP2-CE2
	HTSOP-J8	BD4271EFJ-CE2

Physical Dimension, Tape and Reel Information

Package Name	HRP7
--------------	------

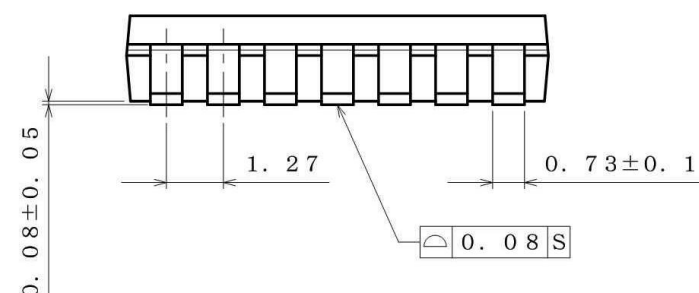
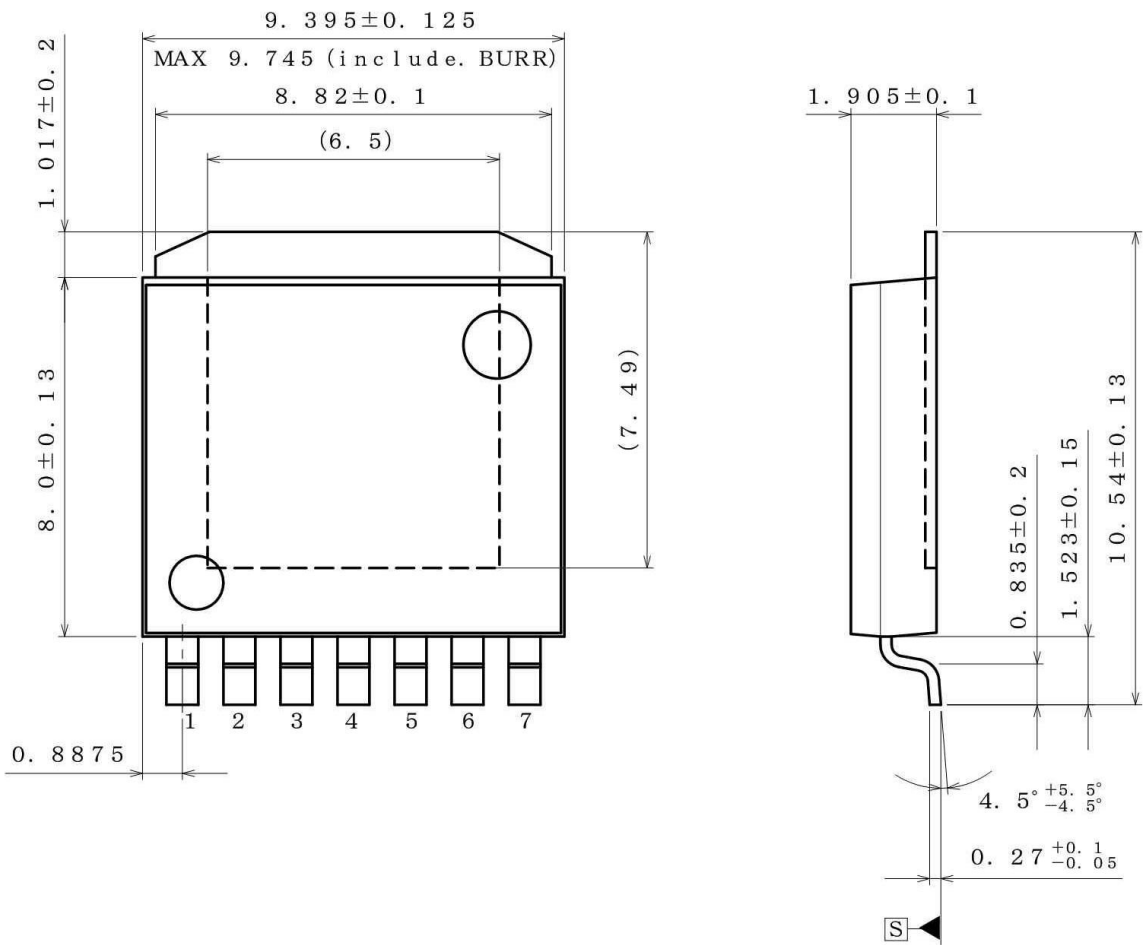

(UNIT ; mm)  
 PKG : HRP7  
 Drawing No. EX542-5002-2

< Tape and Reel Information >

Tape	Embossed carrier tape
Quantity	2000pcs
Direction of feed	TR The direction is the pin 1 of product is at the upper right when you hold reel on the left hand and you pull out the tape on the right hand

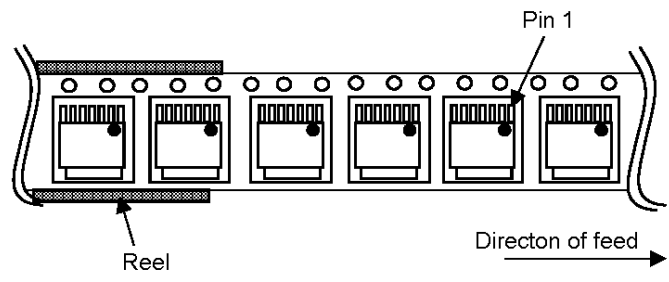

Physical Dimension, Tape and Reel Information – continued

Package Name	TO263-7
--------------	---------

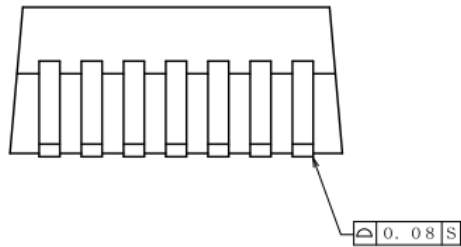
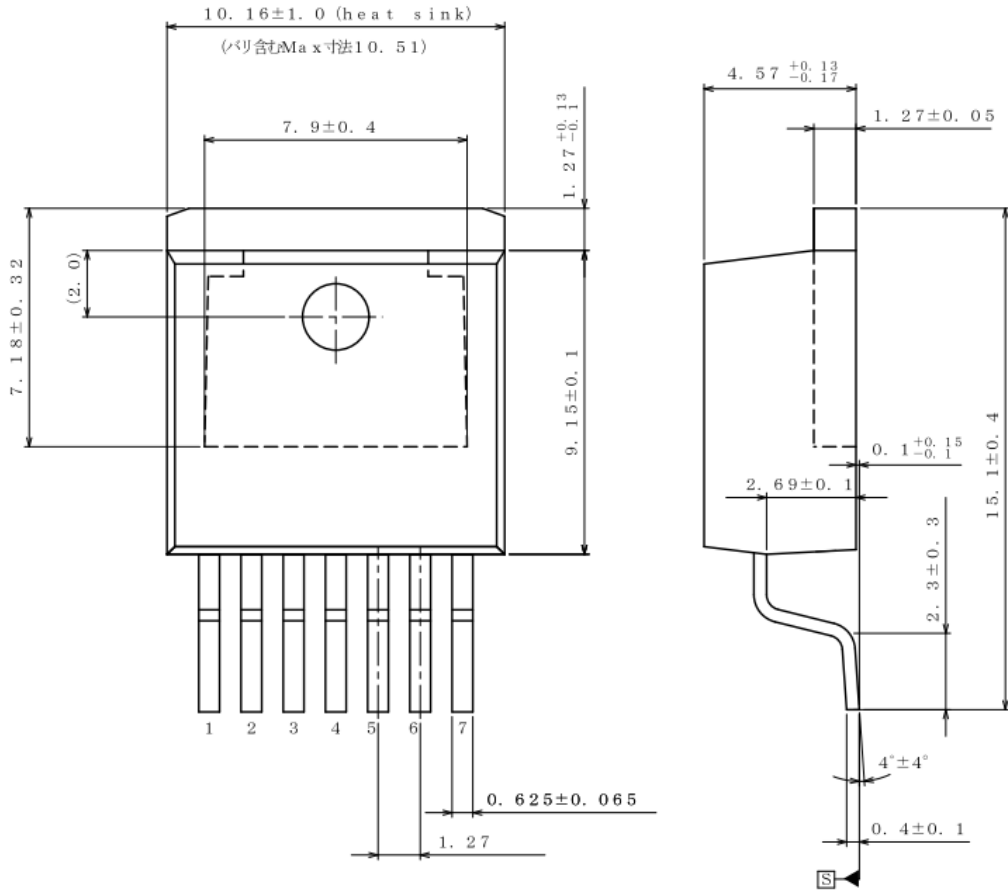

(UNIT : mm)

PKG : TO263-7

Drawing No. EX574-5001

< Tape and Reel Information >

Tape	Embossed carrier tape
Quantity	500pcs
Direction of feed	E2 The direction is the pin 1 of product is at the lower left when you hold reel on the left hand and you pull out the tape on the right hand

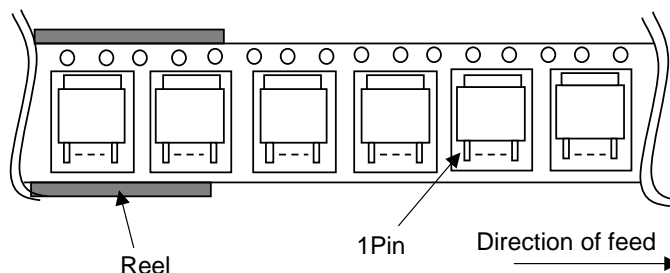

Physical Dimension and Packing Information – continued

Package Name	HTSOP-J8
--------------	----------

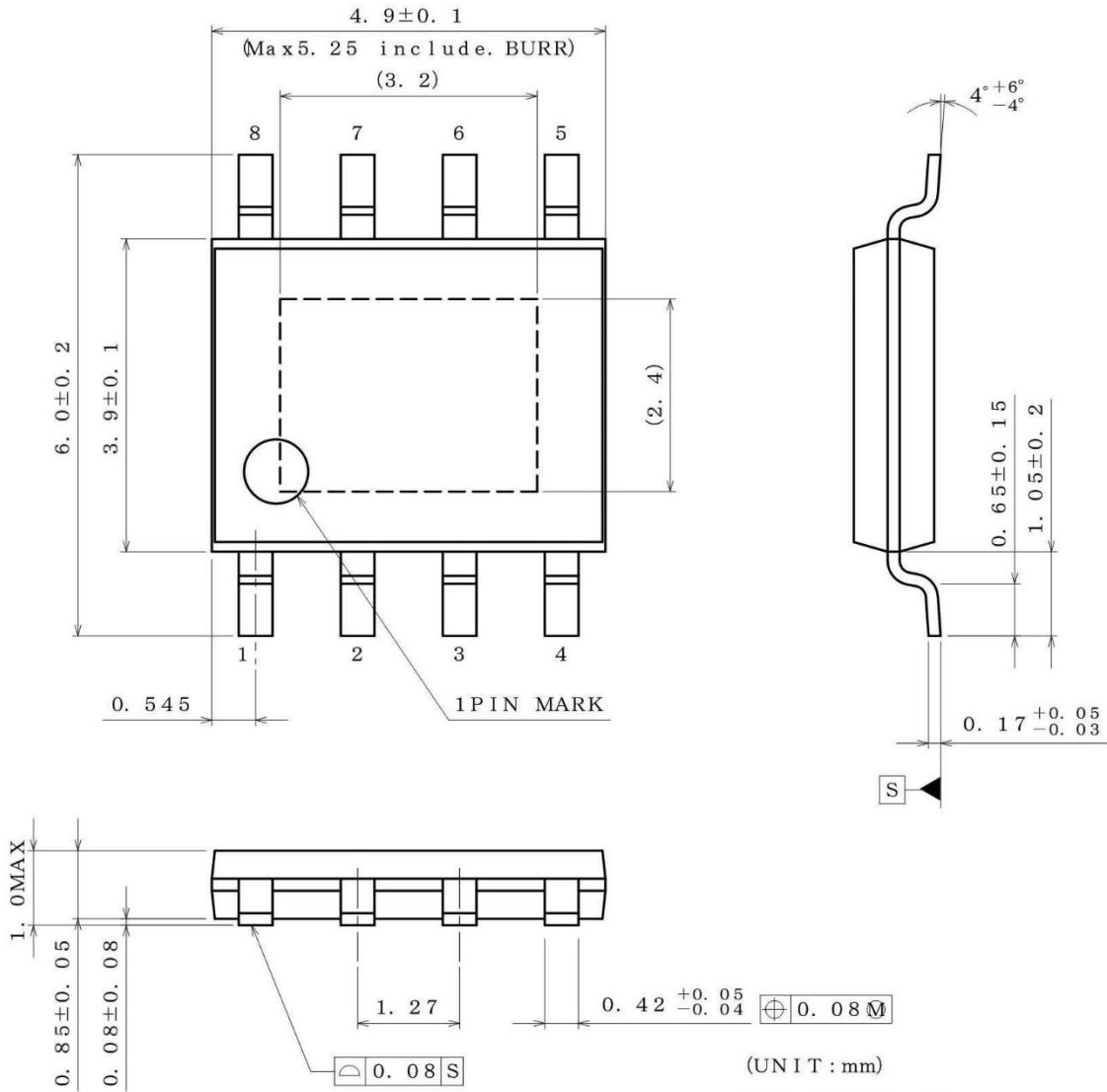

(UNIT : mm)

PKG : HTSOP-J8

Drawing No. EX169-5002-2

< Tape and Reel Information >

Tape	Embossed carrier tape
Quantity	2500pcs
Direction of feed	E2 The direction is the pin 1 of product is at the upper left when you hold reel on the left hand and you pull out the tape on the right hand

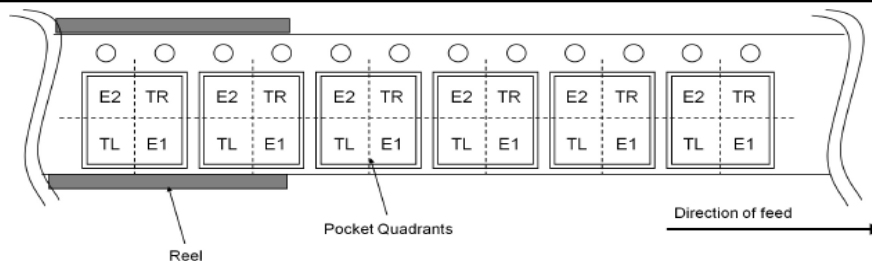

## Revision History

Date	Revision	Changes
Mar.30.2016	001	New Release.
Jun.21.2016	002	TO263-7 PKG added. Thermal resistance format updated.
Mar.25.2021	003	Subtitle correction. Symbol correction "Reset Detection Hysteresis". Symbol correction "CT Upper-side Threshold". Symbol correction "CT Lower-side Threshold". Symbol correction "CT Charge Current". Symbol correction "CT Discharge Current". Formula correction "WDT Monitor Time". Formula correction "WDT Reset Time". Graph title correction Figure 13. Vertical axis label and Graph title correction Figure 14. Legend correction Figure 17. Legend correction Figure 18. Vertical axis label and Graph title correction Figure 19. Vertical axis label and Graph title correction Figure 20. HTSOP-J8 PKG added.
Mar.30.2023	004	Add Key Specifications "Functional Safety Supportive Automotive Products" Electrical Characteristics parameter correction. "CLK Input High Level Voltage". Electrical Characteristics parameter correction. "CLK Input Low Level Voltage". Data correction Figure 11. Add Operational Notes "15. Functional Safety".

# Notice

## Precaution on using ROHM Products

1. If you intend to use our Products in devices requiring extremely high reliability (such as medical equipment <sup>(Note 1)</sup>, aircraft/spacecraft, nuclear power controllers, etc.) and whose malfunction or failure may cause loss of human life, bodily injury or serious damage to property ("Specific Applications"), please consult with the ROHM sales representative in advance. Unless otherwise agreed in writing by ROHM in advance, ROHM shall not be in any way responsible or liable for any damages, expenses or losses incurred by you or third parties arising from the use of any ROHM's Products for Specific Applications.

(Note1) Medical Equipment Classification of the Specific Applications

JAPAN	USA	EU	CHINA
CLASS III	CLASS III	CLASS II b	CLASS III
CLASS IV		CLASS III	

2. ROHM designs and manufactures its Products subject to strict quality control system. However, semiconductor products can fail or malfunction at a certain rate. Please be sure to implement, at your own responsibilities, adequate safety measures including but not limited to fail-safe design against the physical injury, damage to any property, which a failure or malfunction of our Products may cause. The following are examples of safety measures:
  - [a] Installation of protection circuits or other protective devices to improve system safety
  - [b] Installation of redundant circuits to reduce the impact of single or multiple circuit failure
3. Our Products are not designed under any special or extraordinary environments or conditions, as exemplified below. Accordingly, ROHM shall not be in any way responsible or liable for any damages, expenses or losses arising from the use of any ROHM's Products under any special or extraordinary environments or conditions. If you intend to use our Products under any special or extraordinary environments or conditions (as exemplified below), your independent verification and confirmation of product performance, reliability, etc, prior to use, must be necessary:
  - [a] Use of our Products in any types of liquid, including water, oils, chemicals, and organic solvents
  - [b] Use of our Products outdoors or in places where the Products are exposed to direct sunlight or dust
  - [c] Use of our Products in places where the Products are exposed to sea wind or corrosive gases, including Cl<sub>2</sub>, H<sub>2</sub>S, NH<sub>3</sub>, SO<sub>2</sub>, and NO<sub>2</sub>
  - [d] Use of our Products in places where the Products are exposed to static electricity or electromagnetic waves
  - [e] Use of our Products in proximity to heat-producing components, plastic cords, or other flammable items
  - [f] Sealing or coating our Products with resin or other coating materials
  - [g] Use of our Products without cleaning residue of flux (Exclude cases where no-clean type fluxes is used. However, recommend sufficiently about the residue.); or Washing our Products by using water or water-soluble cleaning agents for cleaning residue after soldering
  - [h] Use of the Products in places subject to dew condensation
4. The Products are not subject to radiation-proof design.
5. Please verify and confirm characteristics of the final or mounted products in using the Products.
6. In particular, if a transient load (a large amount of load applied in a short period of time, such as pulse, is applied, confirmation of performance characteristics after on-board mounting is strongly recommended. Avoid applying power exceeding normal rated power; exceeding the power rating under steady-state loading condition may negatively affect product performance and reliability.
7. De-rate Power Dissipation depending on ambient temperature. When used in sealed area, confirm that it is the use in the range that does not exceed the maximum junction temperature.
8. Confirm that operation temperature is within the specified range described in the product specification.
9. ROHM shall not be in any way responsible or liable for failure induced under deviant condition from what is defined in this document.

## Precaution for Mounting / Circuit board design

1. When a highly active halogenous (chlorine, bromine, etc.) flux is used, the residue of flux may negatively affect product performance and reliability.
2. In principle, the reflow soldering method must be used on a surface-mount products, the flow soldering method must be used on a through hole mount products. If the flow soldering method is preferred on a surface-mount products, please consult with the ROHM representative in advance.

For details, please refer to ROHM Mounting specification

### Precautions Regarding Application Examples and External Circuits

1. If change is made to the constant of an external circuit, please allow a sufficient margin considering variations of the characteristics of the Products and external components, including transient characteristics, as well as static characteristics.
2. You agree that application notes, reference designs, and associated data and information contained in this document are presented only as guidance for Products use. Therefore, in case you use such information, you are solely responsible for it and you must exercise your own independent verification and judgment in the use of such information contained in this document. ROHM shall not be in any way responsible or liable for any damages, expenses or losses incurred by you or third parties arising from the use of such information.

### Precaution for Electrostatic

This Product is electrostatic sensitive product, which may be damaged due to electrostatic discharge. Please take proper caution in your manufacturing process and storage so that voltage exceeding the Products maximum rating will not be applied to Products. Please take special care under dry condition (e.g. Grounding of human body / equipment / solder iron, isolation from charged objects, setting of Ionizer, friction prevention and temperature / humidity control).

### Precaution for Storage / Transportation

1. Product performance and soldered connections may deteriorate if the Products are stored in the places where:
  - [a] the Products are exposed to sea winds or corrosive gases, including Cl<sub>2</sub>, H<sub>2</sub>S, NH<sub>3</sub>, SO<sub>2</sub>, and NO<sub>2</sub>
  - [b] the temperature or humidity exceeds those recommended by ROHM
  - [c] the Products are exposed to direct sunshine or condensation
  - [d] the Products are exposed to high Electrostatic
2. Even under ROHM recommended storage condition, solderability of products out of recommended storage time period may be degraded. It is strongly recommended to confirm solderability before using Products of which storage time is exceeding the recommended storage time period.
3. Store / transport cartons in the correct direction, which is indicated on a carton with a symbol. Otherwise bent leads may occur due to excessive stress applied when dropping of a carton.
4. Use Products within the specified time after opening a humidity barrier bag. Baking is required before using Products of which storage time is exceeding the recommended storage time period.

### Precaution for Product Label

A two-dimensional barcode printed on ROHM Products label is for ROHM's internal use only.

### Precaution for Disposition

When disposing Products please dispose them properly using an authorized industry waste company.

### Precaution for Foreign Exchange and Foreign Trade act

Since concerned goods might be fallen under listed items of export control prescribed by Foreign exchange and Foreign trade act, please consult with ROHM in case of export.

### Precaution Regarding Intellectual Property Rights

1. All information and data including but not limited to application example contained in this document is for reference only. ROHM does not warrant that foregoing information or data will not infringe any intellectual property rights or any other rights of any third party regarding such information or data.
2. ROHM shall not have any obligations where the claims, actions or demands arising from the combination of the Products with other articles such as components, circuits, systems or external equipment (including software).
3. No license, expressly or implied, is granted hereby under any intellectual property rights or other rights of ROHM or any third parties with respect to the Products or the information contained in this document. Provided, however, that ROHM will not assert its intellectual property rights or other rights against you or your customers to the extent necessary to manufacture or sell products containing the Products, subject to the terms and conditions herein.

### Other Precaution



1. This document may not be reprinted or reproduced, in whole or in part, without prior written consent of ROHM.
2. The Products may not be disassembled, converted, modified, reproduced or otherwise changed without prior written consent of ROHM.
3. In no event shall you use in any way whatsoever the Products and the related technical information contained in the Products or this document for any military purposes, including but not limited to, the development of mass-destruction weapons.
4. The proper names of companies or products described in this document are trademarks or registered trademarks of ROHM, its affiliated companies or third parties.

**General Precaution**







1. Before you use our Products, you are requested to carefully read this document and fully understand its contents. ROHM shall not be in any way responsible or liable for failure, malfunction or accident arising from the use of any ROHM's Products against warning, caution or note contained in this document.
2. All information contained in this document is current as of the issuing date and subject to change without any prior notice. Before purchasing or using ROHM's Products, please confirm the latest information with a ROHM sales representative.
3. The information contained in this document is provided on an "as is" basis and ROHM does not warrant that all information contained in this document is accurate and/or error-free. ROHM shall not be in any way responsible or liable for any damages, expenses or losses incurred by you or third parties resulting from inaccuracy or errors of or concerning such information.

## Looking for pricing, stock, or lifecycle information?

Click below to explore more details on WIN SOURCE:

-  [View BD4271FP2-CE2 on WIN SOURCE](#)
-  [Rohm Semiconductor](#) Information

## Optimize Your Supply Chain with WIN SOURCE Solutions

-  Global Sourcing Solution
-  Obsolete Management
-  Cost Control Management
-  Shortage Management
-  Alternative Solution
-  Excess Inventory Management