



## Class A, Class AB Microwave Power Silicon NPN Transistor 0.7 W, 960–1215 MHz, 18V

Rev. V1

### Features

- Guaranteed performance @ 1090 MHz, 18 Vdc — Class A
- Output power: 0.2W
- Minimum gain: 10dB
- 100% tested for load mismatch at all phase angles with 10:1 VSWR
- Industry standard package
- Nitride passivated
- Gold metallized, emitter ballasted for long life and resistance to metal migration
- Internal input matching for broadband operation

### Product Image

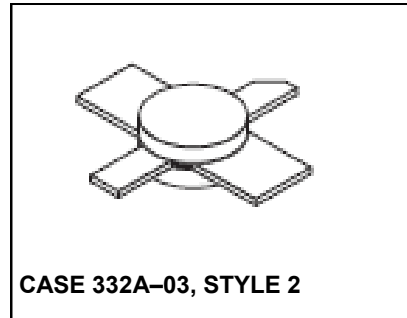

### Description and Applications

Designed for Class A and AB common emitter amplifier applications in the low-power stages of IFF, DME, TACAN, radar transmitters, and CW systems.

### MAXIMUM RATINGS

Rating	Symbol	Value	Unit
Collector–Emitter Voltage	$V_{CEO}$	20	Vdc
Collector–Base Voltage	$V_{CBO}$	50	Vdc
Emitter–Base Voltage	$V_{EBO}$	3.5	Vdc
Collector Current — Continuous	$I_C$	200	mAdc
Total Device Dissipation @ $T_C = 25^\circ\text{C}$ (1) Derate above $25^\circ\text{C}$	$P_D$	7.0 40	Watts mW/ $^\circ\text{C}$

### THERMAL CHARACTERISTICS

Characteristic	Symbol	Max	Unit
Thermal Resistance, Junction to Case (2)	$R_{\theta JC}$	25	$^\circ\text{C/W}$

### ELECTRICAL CHARACTERISTICS ( $T_C = 25^\circ\text{C}$ unless otherwise noted.)

Characteristic	Symbol	Min	Typ	Max	Unit
----------------	--------	-----	-----	-----	------

### OFF CHARACTERISTICS

Collector–Emitter Breakdown Voltage ( $I_C = 5.0$ mAdc, $I_B = 0$ )	$V_{(BR)CEO}$	20	—	—	Vdc
Collector–Emitter Breakdown Voltage ( $I_C = 5.0$ mAdc, $V_{BE} = 0$ )	$V_{(BR)CES}$	50	—	—	Vdc
Collector–Base Breakdown Voltage ( $I_C = 5.0$ mAdc, $I_E = 0$ )	$V_{(BR)CBO}$	50	—	—	Vdc
Emitter–Base Breakdown Voltage ( $I_E = 1.0$ mAdc, $I_C = 0$ )	$V_{(BR)EBO}$	3.5	—	—	Vdc
Collector Cutoff Current ( $V_{CB} = 20$ Vdc, $I_E = 0$ )	$I_{CBO}$	—	—	0.5	mAdc

### ON CHARACTERISTICS

DC Current Gain ( $I_C = 100$ mAdc, $V_{CE} = 5.0$ Vdc)	$h_{FE}$	10	—	100	—
--	----------	----	---	-----	---

1. These devices are designed for RF operation. The total device dissipation rating applies only when the device is operated as RF amplifiers.
2. Thermal Resistance is determined under specified RF operating conditions by infrared measurement techniques.

## Class A, Class AB Microwave Power Silicon NPN Transistor 0.7 W, 960–1215 MHz, 18V

Rev. V1

**ELECTRICAL CHARACTERISTICS — continued** ( $T_C = 25^\circ\text{C}$  unless otherwise noted.)

Characteristic	Symbol	Min	Typ	Max	Unit
<b>DYNAMIC CHARACTERISTICS</b>					
Output Capacitance ( $V_{CB} = 28\text{ Vdc}$ , $I_E = 0$ , $f = 1.0\text{ MHz}$ )	$C_{ob}$	—	2.0	5.0	pF
<b>FUNCTIONAL TESTS</b>					
Common-Emitter Power Gain — Class A ( $V_{CE} = 18\text{ Vdc}$ , $I_C = 100\text{ mAdc}$ , $f = 1090\text{ MHz}$ , $P_{out} = 200\text{ mW}$ )	$G_{PE}$	10	12	—	dB
Common-Emitter Power Gain — Class AB ( $V_{CE} = 18\text{ Vdc}$ , $I_{CQ} = 10\text{ mAdc}$ , $f = 1090\text{ MHz}$ , $P_{out} = 0.7\text{ W}$ )	$G_{PE}$	—	10.7	—	dB
Load Mismatch — Class A ( $V_{CE} = 18\text{ Vdc}$ , $I_C = 100\text{ mAdc}$ , $f = 1090\text{ MHz}$ , $P_{out} = 200\text{ mW}$ , VSWR = 10:1 All Phase Angles)	$\psi$	No Degradation in Power Output			

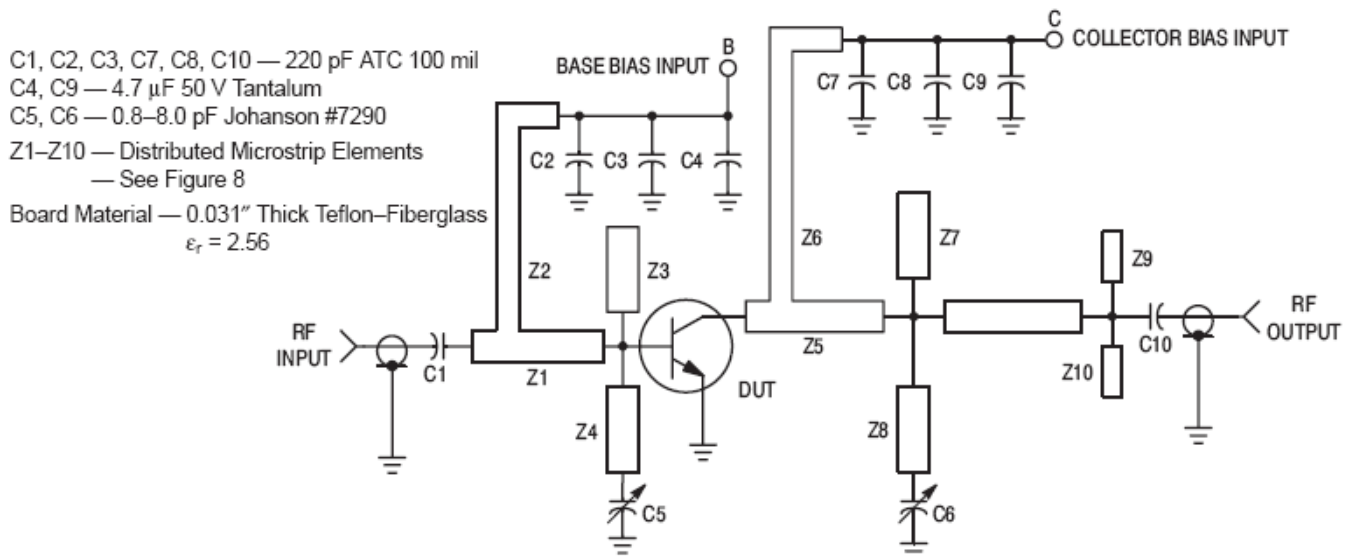

**Class AB Bias Control Circuit**  
18 V Output  $I_{CQ}$  10 mA Nominal

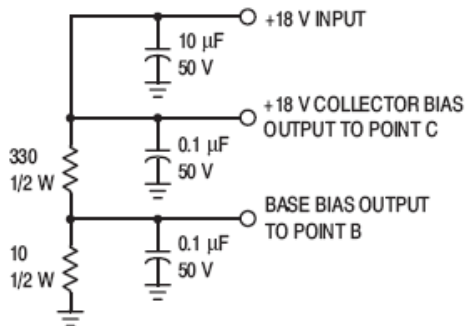

**Class A Constant Current Bias Control Circuit**  
 $I_C = 100\text{ mA}$ ,  $V_{CE} = 18\text{ V}$

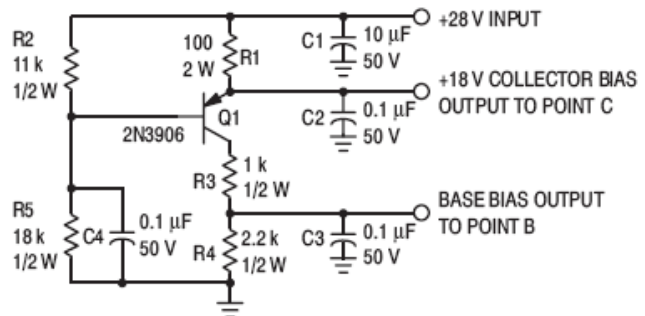

Figure 1. 1090 MHz Test Circuit

**Class A, Class AB Microwave Power Silicon NPN Transistor**  
**0.7 W, 960–1215 MHz, 18V**

Rev. V1

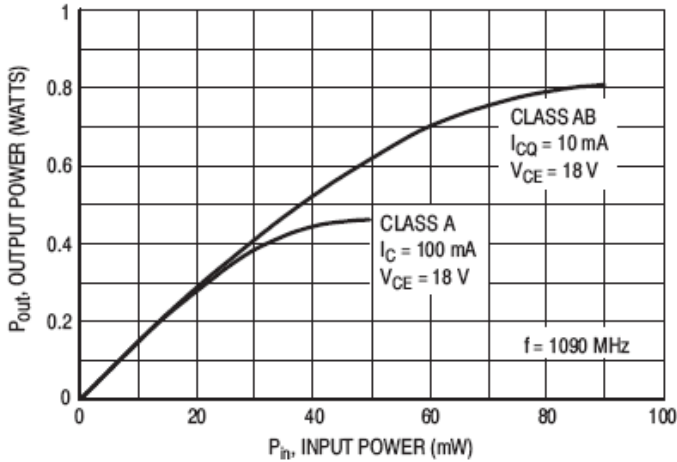

Figure 2. Output Power versus Input Power

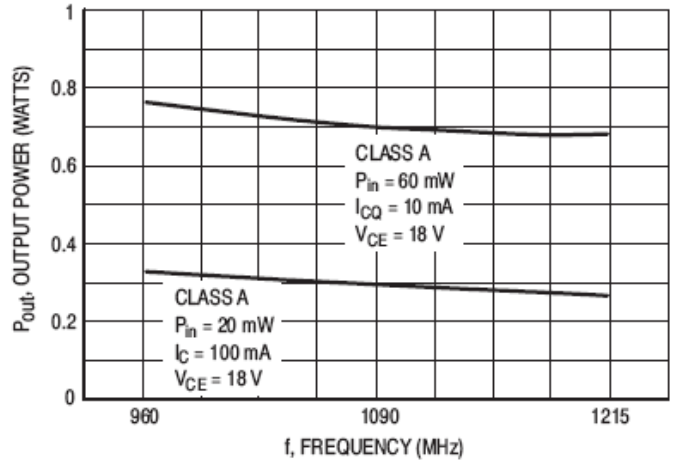

Figure 3. Output Power versus Frequency

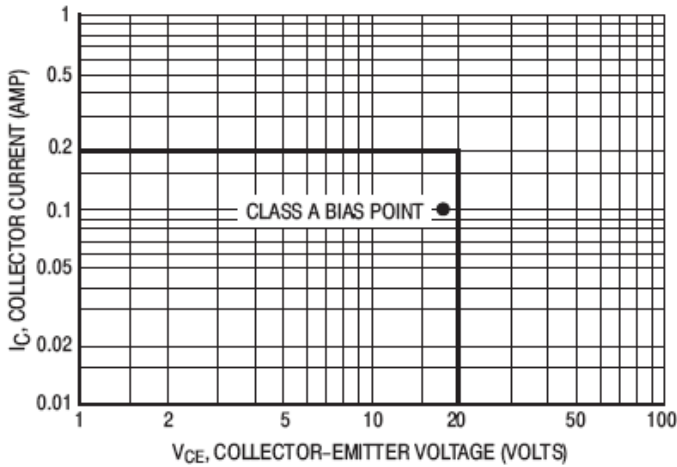

Figure 4. DC Safe Operating Area

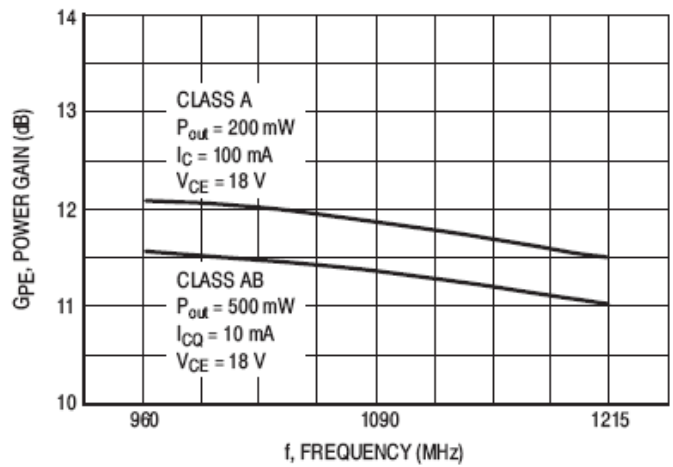
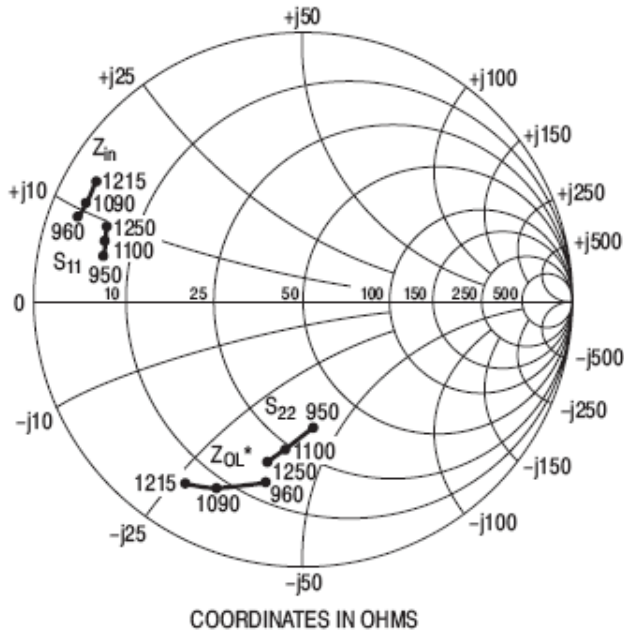

Figure 5. Power Gain versus Frequency

## Class A, Class AB Microwave Power Silicon NPN Transistor 0.7 W, 960–1215 MHz, 18V

Rev. V1



### SERIES EQUIVALENT IMPEDANCES

$P_{out} = 0.5 \text{ W}$ ,  $V_{CE} = 18 \text{ Vdc}$ ,  
 $I_{CQ} = 10 \text{ mA dc}$ , Class AB

f MHz	$Z_{in}$ Ohms	$Z_{OL}^*$ Ohms
960	$3.0 + j9.0$	$16 - j40$
1090	$3.2 + j10$	$8.5 - j31$
1215	$2.8 + j12$	$7.0 - j26$

$Z_{OL}^*$  = Conjugate of the optimum load impedance into which the device output operates at a given output power, voltage, and frequency.

### S-PARAMETERS — $V_{CE} = 18 \text{ Vdc}$ , $I_C = 100 \text{ mA dc}$ , Class A

f (MHz)	$S_{11}$		$S_{21}$		$S_{12}$		$S_{22}$	
	$ S_{11} $	$\angle \phi$	$ S_{21} $	$\angle \phi$	$ S_{12} $	$\angle \phi$	$ S_{22} $	$\angle \phi$
950	0.77	166	2.42	40	0.016	42	0.48	-87
1000	0.78	165	2.36	38	0.016	48	0.50	-90
1050	0.77	163	2.31	33	0.016	46	0.51	-94
1100	0.77	162	2.31	28	0.016	46	0.54	-97
1150	0.78	161	2.20	23	0.015	46	0.57	-100
1200	0.78	159	2.20	19	0.016	47	0.59	-103
1250	0.78	158	2.12	12	0.016	42	0.61	-106

Figure 6. Common-Emitter S-Parameters and Series Equivalent Input/Output Impedances

Replaces MRF1000MA/D

### PACKAGE DIMENSIONS

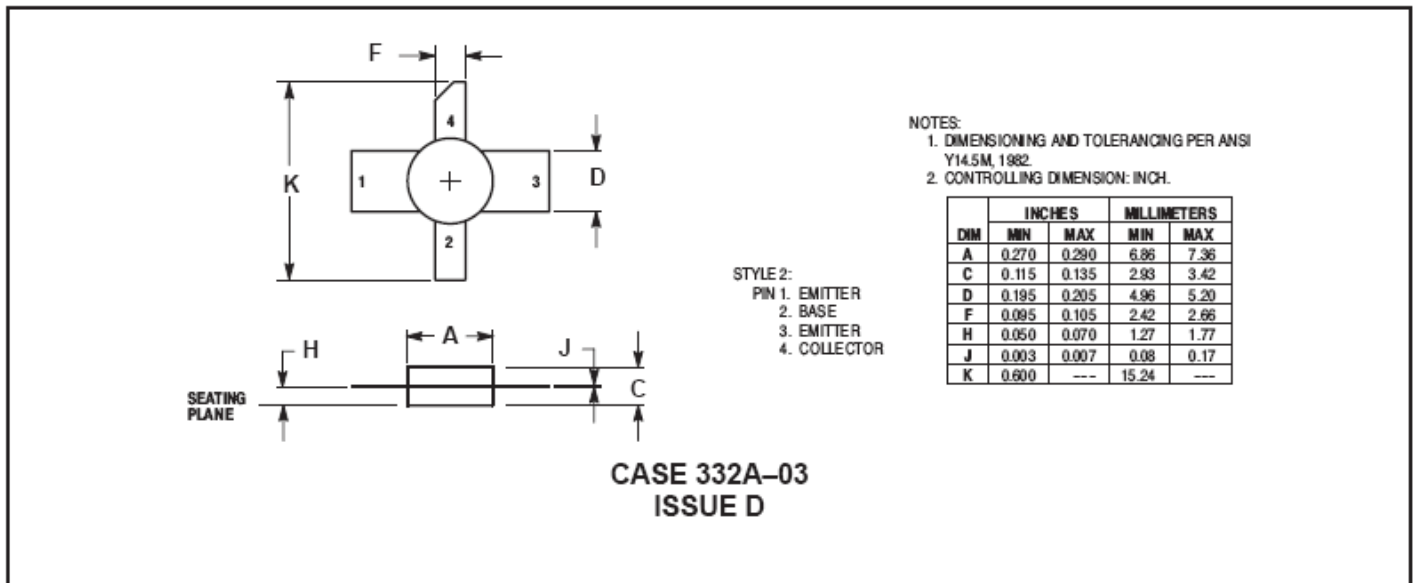

M/A-COM Technology Solutions Inc. All rights reserved.

Information in this document is provided in connection with M/A-COM Technology Solutions Inc ("MACOM") products. These materials are provided by MACOM as a service to its customers and may be used for informational purposes only. Except as provided in MACOM's Terms and Conditions of Sale for such products or in any separate agreement related to this document, MACOM assumes no liability whatsoever. MACOM assumes no responsibility for errors or omissions in these materials. MACOM may make changes to specifications and product descriptions at any time, without notice. MACOM makes no commitment to update the information and shall have no responsibility whatsoever for conflicts or incompatibilities arising from future changes to its specifications and product descriptions. No license, express or implied, by estoppel or otherwise, to any intellectual property rights is granted by this document.

THESE MATERIALS ARE PROVIDED "AS IS" WITHOUT WARRANTY OF ANY KIND, EITHER EXPRESS OR IMPLIED, RELATING TO SALE AND/OR USE OF MACOM PRODUCTS INCLUDING LIABILITY OR WARRANTIES RELATING TO FITNESS FOR A PARTICULAR PURPOSE, CONSEQUENTIAL OR INCIDENTAL DAMAGES, MERCHANTABILITY, OR INFRINGEMENT OF ANY PATENT, COPYRIGHT OR OTHER INTELLECTUAL PROPERTY RIGHT. MACOM FURTHER DOES NOT WARRANT THE ACCURACY OR COMPLETENESS OF THE INFORMATION, TEXT, GRAPHICS OR OTHER ITEMS CONTAINED WITHIN THESE MATERIALS. MACOM SHALL NOT BE LIABLE FOR ANY SPECIAL, INDIRECT, INCIDENTAL, OR CONSEQUENTIAL DAMAGES, INCLUDING WITHOUT LIMITATION, LOST REVENUES OR LOST PROFITS, WHICH MAY RESULT FROM THE USE OF THESE MATERIALS.

MACOM products are not intended for use in medical, lifesaving or life sustaining applications. MACOM customers using or selling MACOM products for use in such applications do so at their own risk and agree to fully indemnify MACOM for any damages resulting from such improper use or sale.

## Looking for pricing, stock, or lifecycle information?

Click below to explore more details on WIN SOURCE:

- ⊖ [View MRF1000MB](#) on WIN SOURCE
- ⊖ [M/A-Com Technology Solutions](#) Information

## Optimize Your Supply Chain with WIN SOURCE Solutions

- ✓ Global Sourcing Solution
- ✓ Obsolete Management
- ✓ Cost Control Management
- ✓ Shortage Management
- ✓ Alternative Solution
- ✓ Excess Inventory Management