



**THE DATASHEET OF  
BLM9D2325-20ABZ**



# BLM9D2325-20AB

LDMOS 2-stage integrated Doherty MMIC

Rev. 1 — 24 July 2017

AMPLEON

Product data sheet

## 1. Product profile

### 1.1 General description

The BLM9D2325-20AB is a 2-stage fully integrated Doherty MMIC solution using Ampleon's state of the art GEN9 LDMOS technology. The carrier and peaking device, input splitter and output combiner are integrated in a single package. This multiband device is perfectly suited as a final device in massive MIMO or small cell applications in the frequency range from 2300 MHz to 2500 MHz. Available in PQFN outline.

**Table 1. Application performance**

Typical RF performance at  $T_{case} = 25\text{ }^{\circ}\text{C}$ ;  $I_{Dq} = 39\text{ mA}$  (driver and final stages);

$V_{GSq(peaking)} = V_{GSq(carrier)} - 0.50\text{ V}$ . Test signal: 3GPP test model 1; 64 DPCH; PAR = 9.9 dB at 0.01 % probability on CCDF.

Test signal	f	V <sub>DS</sub>	P <sub>L(AV)</sub>	G <sub>p</sub>	η <sub>D</sub>	ACPR <sub>5M</sub>
	(MHz)	(V)	(W)	(dB)	(%)	(dBc)
single carrier W-CDMA	2350	28	3.55	27.1	42.1	-36.3

### 1.2 Features and benefits

- Integrated input splitter
- Integrated output combiner
- Very high efficiency thanks to asymmetry
- Designed for broadband operation (frequency 2300 MHz to 2500 MHz)
- Independent control of carrier and peaking bias
- Integrated ESD protection
- Excellent thermal stability
- Source impedance 50 Ω; high power gain
- Compliant to Directive 2002/95/EC, regarding restriction of hazardous substances (RoHS)

### 1.3 Applications

- RF power MMIC for multi-carrier and multi-standard GSM, W-CDMA and LTE base stations in the 2300 MHz to 2500 MHz frequency range.

## 2. Pinning information

### 2.1 Pinning

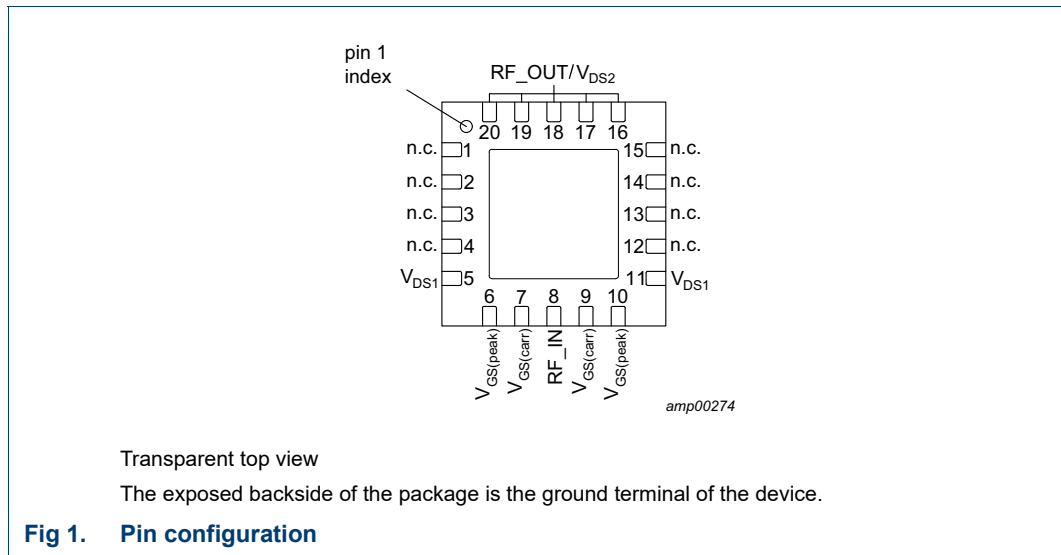

### 2.2 Pin description

Table 2. Pin description

Symbol	Pin	Description
n.c.	1	not connected
n.c.	2	not connected
n.c.	3	not connected
n.c.	4	not connected
$V_{DS1}$	5	drain-source voltage of driver stages
$V_{GS(peak)}$	6	gate-source voltage of peaking
$V_{GS(carr)}$	7	gate-source voltage of carrier
RF_IN	8	RF input
$V_{GS(carr)}$	9	gate-source voltage of carrier
$V_{GS(peak)}$	10	gate-source voltage of peaking
$V_{DS1}$	11	drain-source voltage of driver stages
n.c.	12	not connected
n.c.	13	not connected
n.c.	14	not connected
n.c.	15	not connected
RF_OUT/ $V_{DS2}$	16	RF output / drain-source voltage of final stages
RF_OUT/ $V_{DS2}$	17	RF output / drain-source voltage of final stages
RF_OUT/ $V_{DS2}$	18	RF output / drain-source voltage of final stages

Table 2. Pin description ...continued

Symbol	Pin	Description
RF_OUT/ $V_{DS2}$	19	RF output / drain-source voltage of final stages
RF_OUT/ $V_{DS2}$	20	RF output / drain-source voltage of final stages
GND	flange	RF ground

### 3. Ordering information

Table 3. Ordering information

Type number	Package		
	Name	Description	Version
BLM9D2325-20AB	PQFN20	plastic thermal enhanced quad flat package; no leads; 20 terminals; body 8.0 x 8.0 x 2.1 mm	SOT1462-1

### 4. Block diagram

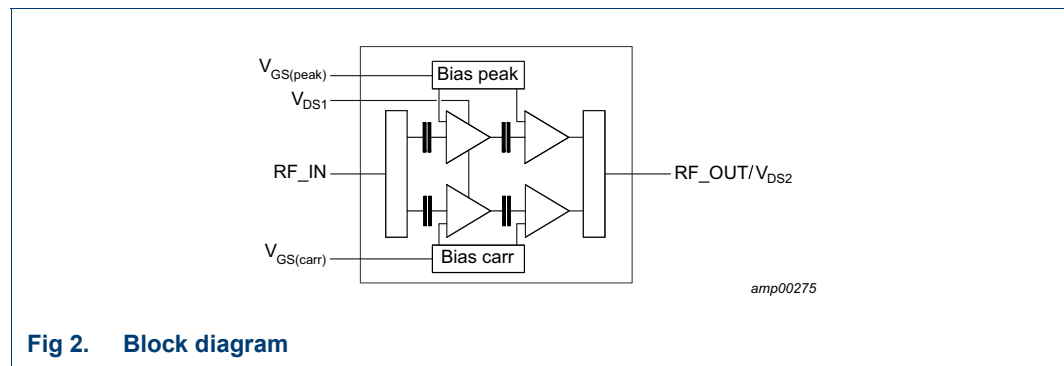

### 5. Limiting values

Table 4. Limiting values

In accordance with the Absolute Maximum Rating System (IEC 60134).

Symbol	Parameter	Conditions	Min	Max	Unit
$V_{DS}$	drain-source voltage		-	65	V
$V_{GS}$	gate-source voltage		-0.5	+13	V
$T_{stg}$	storage temperature		-65	+150	°C
$T_j$	junction temperature	[1]	-	175	°C

[1] Continuous use at maximum temperature will affect the reliability. For details refer to the online MTF calculator.

## 6. Thermal characteristics

**Table 5. Thermal characteristics**

Measured for total device.

Symbol	Parameter	Conditions	Value	Unit
R <sub>th(j-c)</sub>	thermal resistance from junction to case	T <sub>case</sub> = 90 °C; P <sub>L(AV)</sub> = 3 W [1]	12	K/W
		T <sub>case</sub> = 90 °C; P <sub>L(AV)</sub> = 1.25 W [1]	17	K/W

[1] When operated with a 1-carrier W-CDMA with PAR = 8 dB.

## 7. Characteristics

**Table 6. DC characteristics**

T<sub>case</sub> = 25 °C; unless otherwise specified.

Symbol	Parameter	Conditions	Min	Typ	Max	Unit
<b>Carrier</b>						
V <sub>GSq</sub>	gate-source quiescent voltage	V <sub>DS</sub> = 28 V; I <sub>D</sub> = 37 mA	1.65	2.2	2.75	V
I <sub>GSS</sub>	gate leakage current	V <sub>GS</sub> = 1 V; V <sub>DS</sub> = 0 V	-	-	140	nA
<b>Peaking</b>						
I <sub>GSS</sub>	gate leakage current	V <sub>GS</sub> = 1 V; V <sub>DS</sub> = 0 V	-	-	140	nA
<b>Final stages</b>						
I <sub>DSS</sub>	drain leakage current	V <sub>GS</sub> = 0 V; V <sub>DS</sub> = 28 V	-	-	1.4	μA
<b>Driver stages</b>						
I <sub>DSS</sub>	drain leakage current	V <sub>GS</sub> = 0 V; V <sub>DS</sub> = 28 V	-	-	1.4	μA

**Table 7. RF Characteristics**

Typical RF performance at T<sub>case</sub> = 25 °C; V<sub>DS</sub> = 28 V; I<sub>Dq</sub> = 37 mA (carrier);

V<sub>GSq(peaking)</sub> = V<sub>GSq(carrier)</sub> - 0.5 V; P<sub>L</sub> = 2 W; f = 2.5 GHz. Unless otherwise specified, measured in an Ampleon production circuit.

Symbol	Parameter	Conditions	Min	Typ	Max	Unit
<b>Test signal: pulsed CW</b>						
G <sub>p</sub>	power gain		26.5	28	29.5	dB
η <sub>D</sub>	drain efficiency	P <sub>L</sub> = 2 W	35	39	-	%
		P <sub>L</sub> = P <sub>L(3dB)</sub>	45	50	-	%
RL <sub>in</sub>	input return loss		-	-14	-10	dB
P <sub>L(3dB)</sub>	output power at 3 dB gain compression		43	43.4	-	dBm

## 8. Application information

**Table 8. Typical performance**

Test signal: 1-carrier W-CDMA;  $T_{case} = 25\text{ °C}$ ;  $V_{DS} = 28\text{ V}$ ;  $I_{DQ} = 39\text{ mA}$  (driver and final stages); test model 1; 64 DPCH; PAR = 9.9 dB at 0.01 % probability CCDF; unless otherwise specified, measured in an Ampleon 2300 MHz to 2400 MHz frequency band asymmetrical Doherty application circuit.

Symbol	Parameter	Conditions	Min	Typ	Max	Unit
$P_{L(3dB)}$	output power at 3 dB gain compression	f = 2350 MHz <a href="#">[1]</a>	-	43.3	-	dBm
$\varphi_{s21}/\varphi_{s21(norm)}$	normalized phase response	f = 2350 MHz; at 3 dB compression point <a href="#">[2]</a>	-	-14.2	-	°
$\eta_D$	drain efficiency	8 dB OBO ( $P_{L(AV)} = 35.5\text{ dBm}$ ); f = 2350 MHz	-	42.1	-	%
$G_p$	power gain	$P_{L(AV)} = 35.5\text{ dBm}$ ; f = 2350 MHz	-	27.1	-	dB
$B_{video}$	video bandwidth	$P_{L(AV)} = 38.5\text{ dBm}$ set to obtain IMD3 = -30 dBc; 2-tone CW; f = 2350 MHz	-	216	-	MHz
$G_{flat}$	gain flatness	$P_{L(AV)} = 35.5\text{ dBm}$ ; f = 2300 MHz to 2400 MHz	-	0.7	-	dB
ACPR <sub>5M</sub>	adjacent channel power ratio (5M)	$P_{L(AV)} = 35.5\text{ dBm}$ ; f = 2350 MHz	-	-36.3	-	dBc
$\Delta G/\Delta T$	gain variation with temperature	f = 2350 MHz	-	0.04	-	dB/°C
K	Rollett stability factor	$T_{case} = -40\text{ °C}$ ; f = 0.15 GHz to 5 GHz <a href="#">[3]</a>	-	>1.7	-	

- [1] Pulsed CW power sweep measurement ( $\delta = 10\%$ ,  $t_p = 100\text{ }\mu\text{s}$ ).
- [2] 25 ms CW power sweep measurement.
- [3] S-parameters measured with load-pull jig.

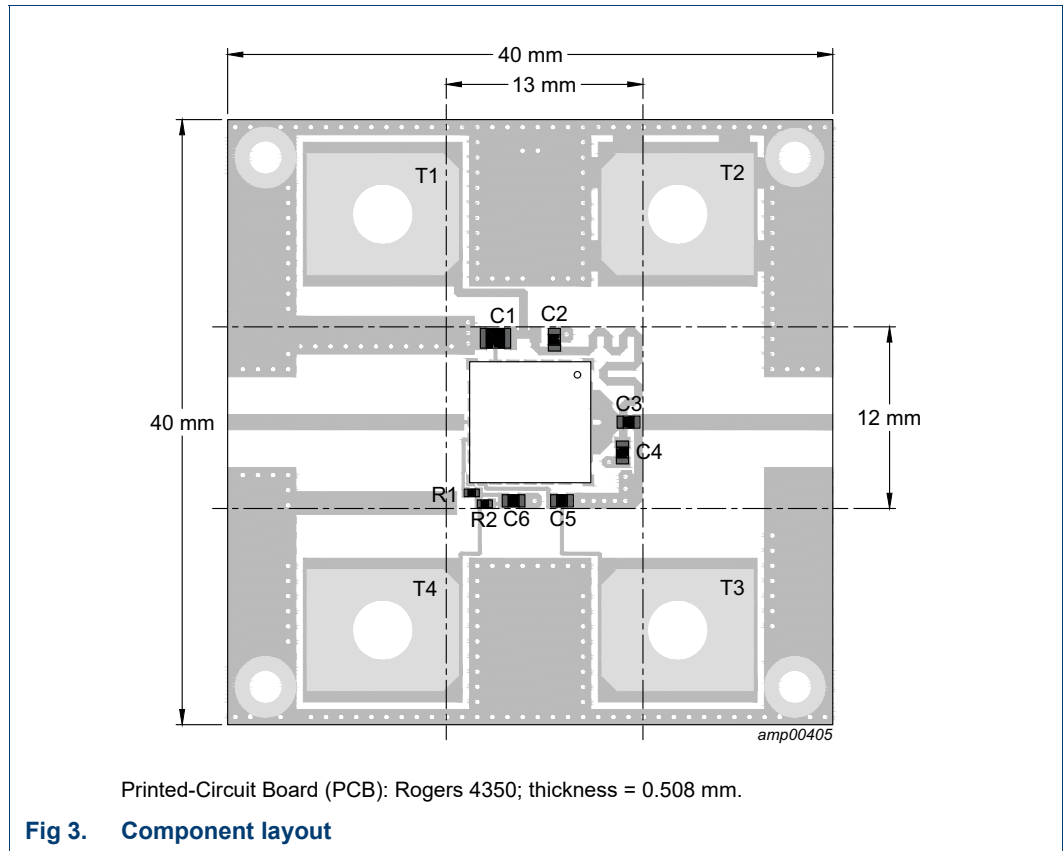

**Table 9. Demo test circuit list of components**

See [Figure 3](#) for component layout.

Component	Description	Value	Remarks
C1	multilayer ceramic chip capacitor	10 $\mu$ F, 50 V	Murata: GRM31CR61H106KA12L
C2	multilayer ceramic chip capacitor	7.5 $\pm$ 0.5 pF	Murata: GQM1875C2E7R5BB12
C3	multilayer ceramic chip capacitor	2.4 $\pm$ 0.5 pF	Murata: GQM1875C2E2R4BB12
C4	multilayer ceramic chip capacitor	3.0 $\pm$ 0.5 pF	Murata: GQM1875C2E3R0BB12
C5, C6	multilayer ceramic chip capacitor	1 $\mu$ F, 6.3 V	TDK: C1608X5R0J106K080AB
J1	SMA Coaxial panel connector male		Hubner & Suhner: 13_SMA-50-0-2/111_N
J2	SMA Coaxial panel connector female		Hubner & Suhner: 13_SMA-50-0-2/111_N
R1	SMD resistor	820 $\Omega$ , $\pm$ 1 %	Multicomp: MC805
R2	SMD resistor	5.1 $\Omega$ , $\pm$ 1 %	Multicomp: MC805
T1, T2, T3, T4	PCB Terminal	6.35 mm $\times$ 0.81 mm; 4.1 mm	TE connectivity

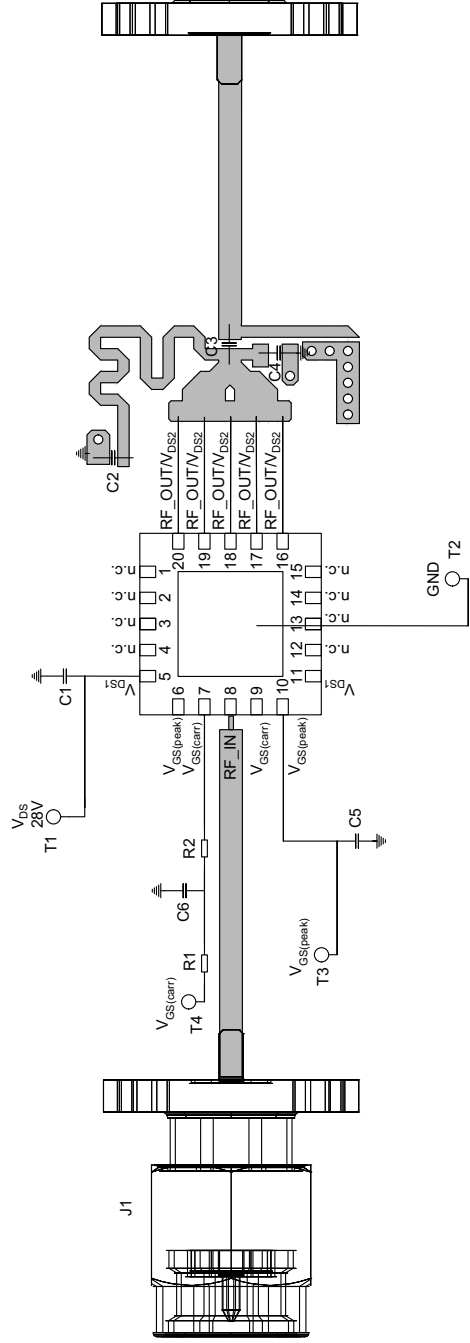

Fig 4. Electrical schematic

### 8.1 Ruggedness in a Doherty operation

The BLM9D2325-20AB is capable of withstanding a load mismatch corresponding to VSWR = 10 : 1 through all phases under the following conditions:  $V_{DS} = 32 \text{ V}$ ;  $I_{Dq} = 35 \text{ mA}$  (carrier);  $V_{GSq(\text{peaking})} = V_{GSq(\text{carrier})} - 0.5 \text{ V}$ ;  $P_1$  corresponding to  $P_{L(3\text{dB})}$  under  $Z_S = 50 \Omega$  load;  $f = 2500 \text{ MHz}$  (CW);  $T_{\text{case}} = 25 \text{ }^\circ\text{C}$ .

### 8.2 Impedance information

**Table 10. Typical impedance for optimum Doherty operation**

Measured load-pull data per section; test signal: pulsed CW;  $T_{\text{case}} = 25 \text{ }^\circ\text{C}$ ;  $V_{DS} = 28 \text{ V}$ ;  $I_{Dq} = 35 \text{ mA}$  (carrier);  $V_{GSq(\text{peaking})} = V_{GSq(\text{carrier})} - 0.5 \text{ V}$ ;  $t_p = 100 \mu\text{s}$ ;  $\delta = 10 \%$ . Typical values.

f (MHz)	tuned for optimum Doherty operation				
	$Z_L$ ( $\Omega$ )	$G_{p(\text{max})}$ (dB)	$P_L$ (dBm)	$\eta_{\text{add}}$ [1] (%)	$\eta_{\text{add}}$ [2] (%)
2300	5.30 – j0.46	27.80	43.70	52.10	50.90
2400	5.63 – j1.31	28.40	44.00	55.00	54.00
2500	5.67 – j1.31	28.30	44.10	56.90	54.80

[1] at 43 dBm (nearly 3 dB compression point).

[2] at 35 dBm (nearly 8 dB OBO point).

### 8.3 Graphs

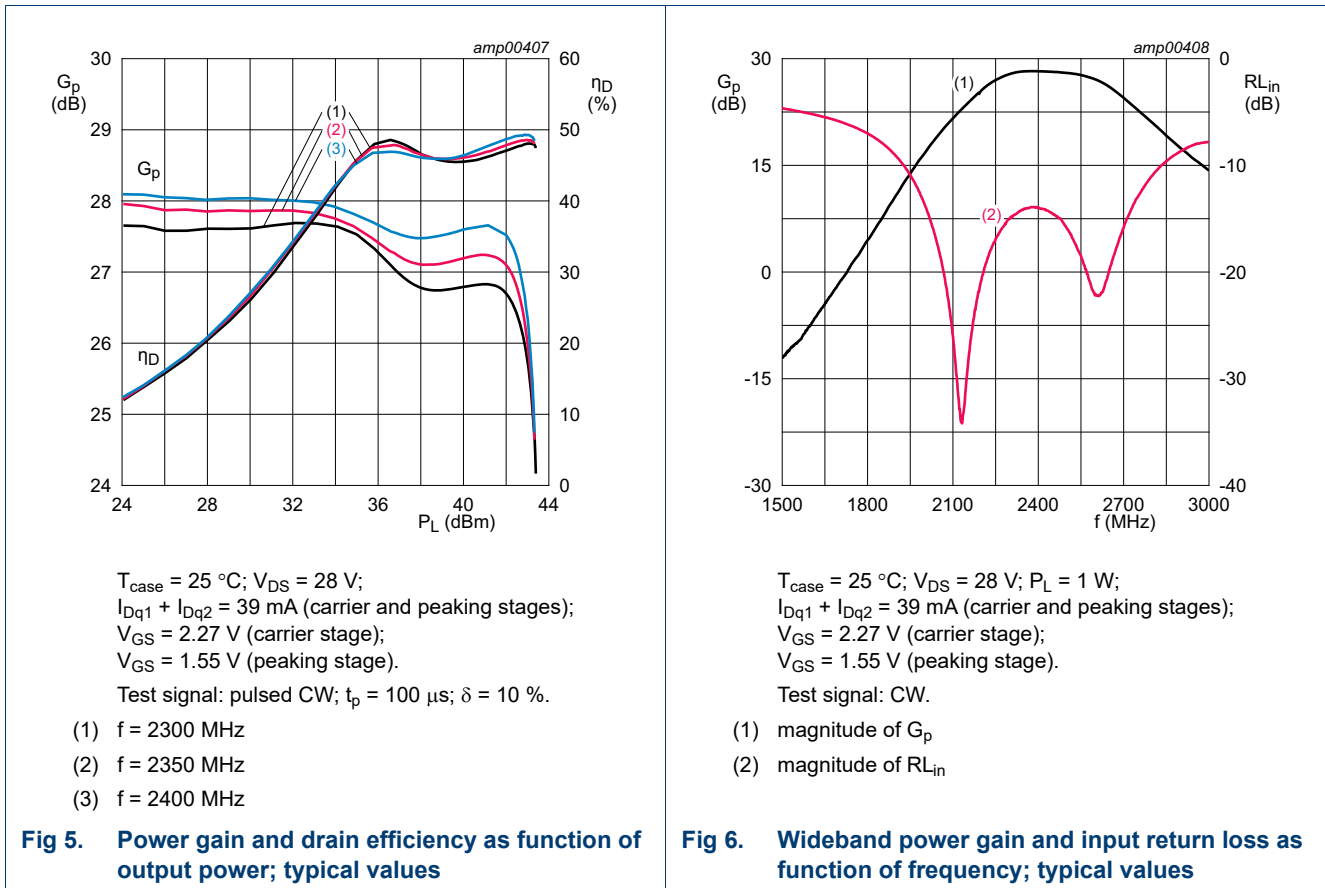

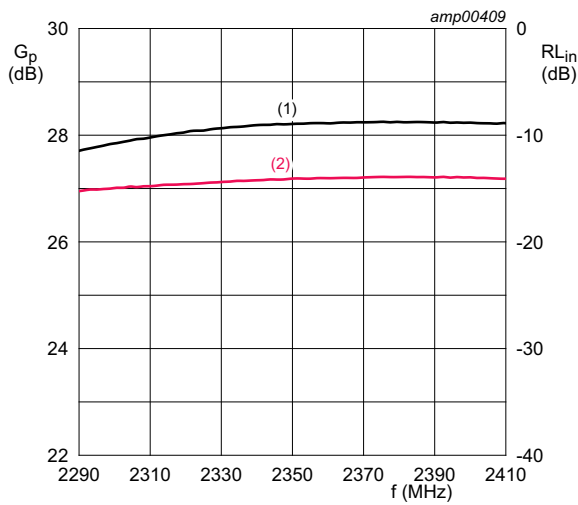

$T_{case} = 25\text{ }^\circ\text{C}$ ;  $V_{DS} = 28\text{ V}$ ;  $P_L = 1\text{ W}$ ;  
 $I_{Dq1} + I_{Dq2} = 39\text{ mA}$  (carrier and peaking stages);  
 $V_{GS} = 2.27\text{ V}$  (carrier stage);  
 $V_{GS} = 1.55\text{ V}$  (peaking stage).

Test signal: CW.

- (1) magnitude of  $G_p$
- (2) magnitude of  $RL_{in}$

**Fig 7. In-band power gain and input return loss as function of frequency; typical values**

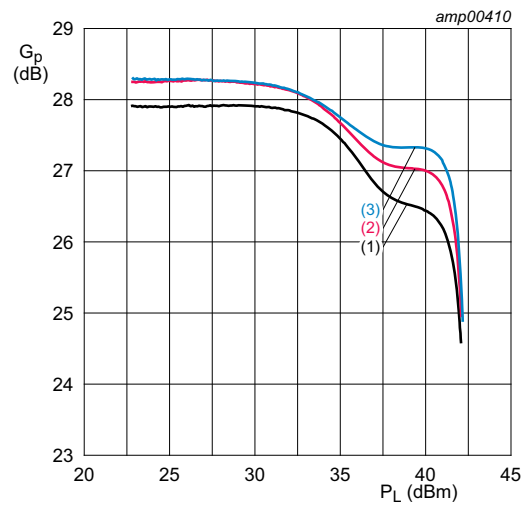

$T_{case} = 25\text{ }^\circ\text{C}$ ;  $V_{DS} = 28\text{ V}$ ;  
 $I_{Dq1} + I_{Dq2} = 39\text{ mA}$  (carrier and peaking stages);  
 $V_{GS} = 2.27\text{ V}$  (carrier stage);  
 $V_{GS} = 1.55\text{ V}$  (peaking stage).

Test signal: 25 ms CW power sweep.

- (1)  $f = 2300\text{ MHz}$
- (2)  $f = 2350\text{ MHz}$
- (3)  $f = 2400\text{ MHz}$

**Fig 8. Power gain as a function of output power; typical values**

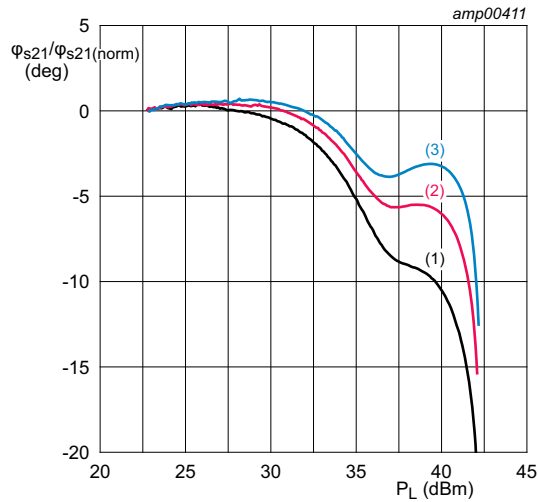

$T_{\text{case}} = 25\text{ }^\circ\text{C}$ ;  $V_{\text{DS}} = 28\text{ V}$ ;  $I_{\text{Dq1}} + I_{\text{Dq2}} = 39\text{ mA}$  (carrier and peaking stages);  
 $V_{\text{GS}} = 2.27\text{ V}$  (carrier stage);  $V_{\text{GS}} = 1.55\text{ V}$  (peaking stage).

Test signal: 25 ms CW power sweep.

- (1)  $f = 2300\text{ MHz}$
- (2)  $f = 2350\text{ MHz}$
- (3)  $f = 2400\text{ MHz}$

**Fig 9. Normalized phase response as a function of output power; typical values**

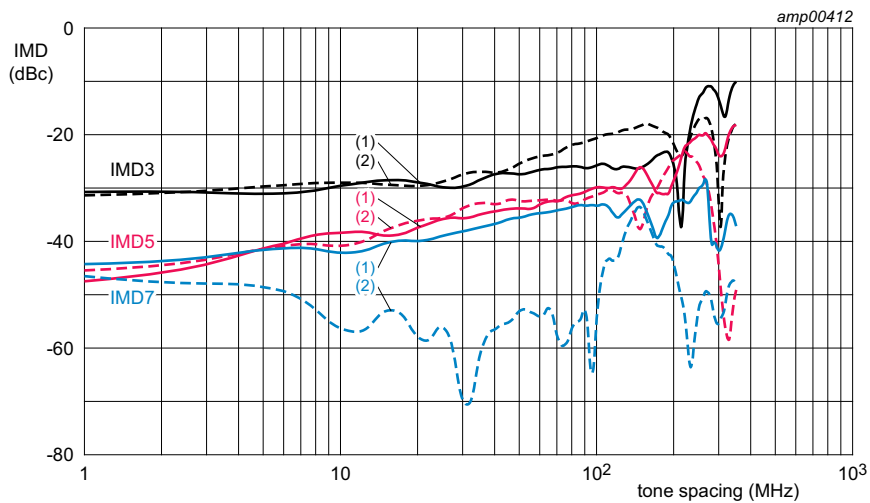

$T_{\text{case}} = 25\text{ }^\circ\text{C}$ ;  $V_{\text{DS}} = 28\text{ V}$ ;  $I_{\text{Dq1}} + I_{\text{Dq2}} = 39\text{ mA}$  (carrier and peaking stages);  
 $V_{\text{GS}} = 2.27\text{ V}$  (carrier stage);  $V_{\text{GS}} = 1.55\text{ V}$  (peaking stage).

Test signal: 2-tone CW;  $f_c = 2350\text{ MHz}$ .

- (1) IMD low
- (2) IMD high

**Fig 10. Intermodulation distortion as a function of tone spacing; typical values**

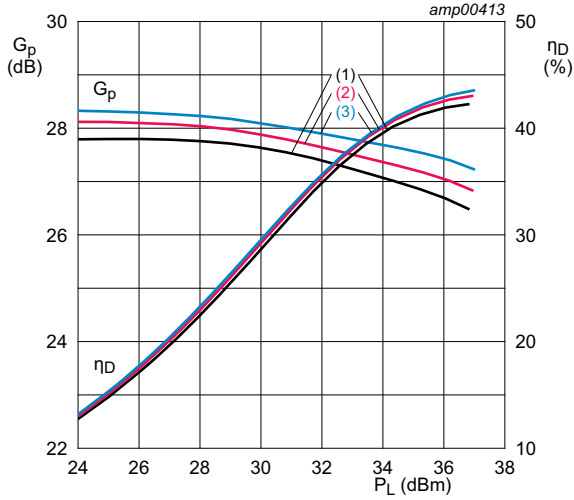

$T_{case} = 25\text{ }^{\circ}\text{C}$ ;  $V_{DS} = 28\text{ V}$ ;  
 $I_{Dq1} + I_{Dq2} = 39\text{ mA}$  (carrier and peaking stages);  
 $V_{GS} = 2.27\text{ V}$  (carrier stage);  
 $V_{GS} = 1.55\text{ V}$  (peaking stage).  
 Test signal: 1-carrier W-CDMA; test model 1; 64 DPCH;  
 PAR = 9.9 dB at 0.01 % probability CCDF.

- (1)  $f = 2300\text{ MHz}$
- (2)  $f = 2350\text{ MHz}$
- (3)  $f = 2400\text{ MHz}$

**Fig 11. Power gain and drain efficiency as function of output power; typical values**

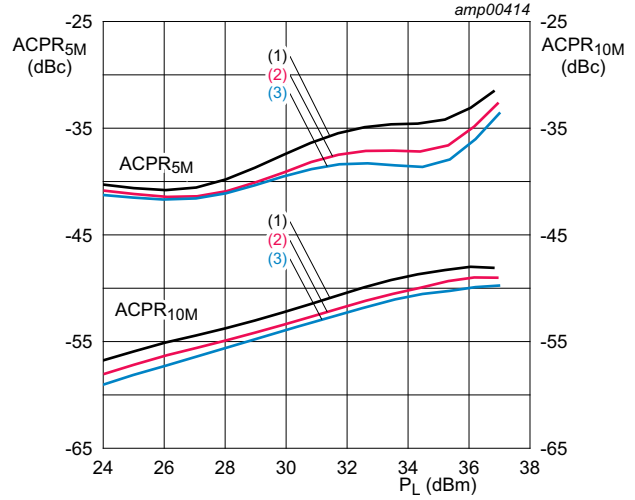

$T_{case} = 25\text{ }^{\circ}\text{C}$ ;  $V_{DS} = 28\text{ V}$ ;  
 $I_{Dq1} + I_{Dq2} = 39\text{ mA}$  (carrier and peaking stages);  
 $V_{GS} = 2.27\text{ V}$  (carrier stage);  
 $V_{GS} = 1.55\text{ V}$  (peaking stage).  
 Test signal: 1-carrier W-CDMA; test model 1; 64 DPCH;  
 PAR = 9.9 dB at 0.01 % probability CCDF.

- (1)  $f = 2300\text{ MHz}$
- (2)  $f = 2350\text{ MHz}$
- (3)  $f = 2400\text{ MHz}$

**Fig 12. Adjacent channel power ratio as a function of output power; typical values**

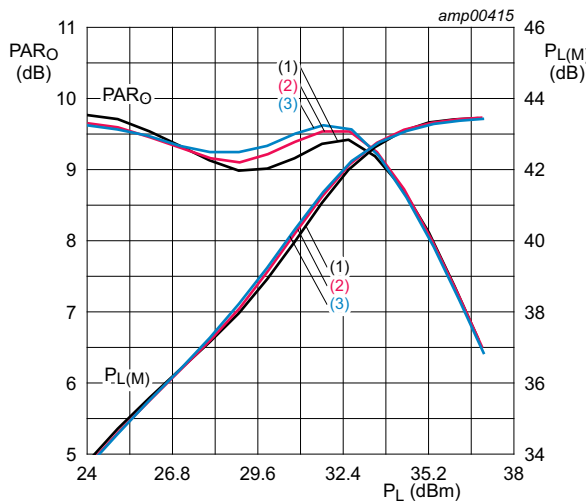

$T_{case} = 25\text{ }^{\circ}\text{C}$ ;  $V_{DS} = 28\text{ V}$ ;  $I_{Dq1} + I_{Dq2} = 39\text{ mA}$  (carrier and peaking stages);  
 $V_{GS} = 2.27\text{ V}$  (carrier stage);  $V_{GS} = 1.55\text{ V}$  (peaking stage).  
 Test signal: 1-carrier W-CDMA; test model 1; 64 DPCH; PAR = 9.9 dB at 0.01 % probability CCDF.

- (1)  $f = 2300\text{ MHz}$
- (2)  $f = 2350\text{ MHz}$
- (3)  $f = 2400\text{ MHz}$

**Fig 13. Output peak-to-average ratio and peak output power as function of output power; typical values**

9. Package outline

PQFN20: plastic thermal enhanced quad flat package; no leads; 20 terminals; body 8.0 x 8.0 x 2.1 mm

SOT1462-1

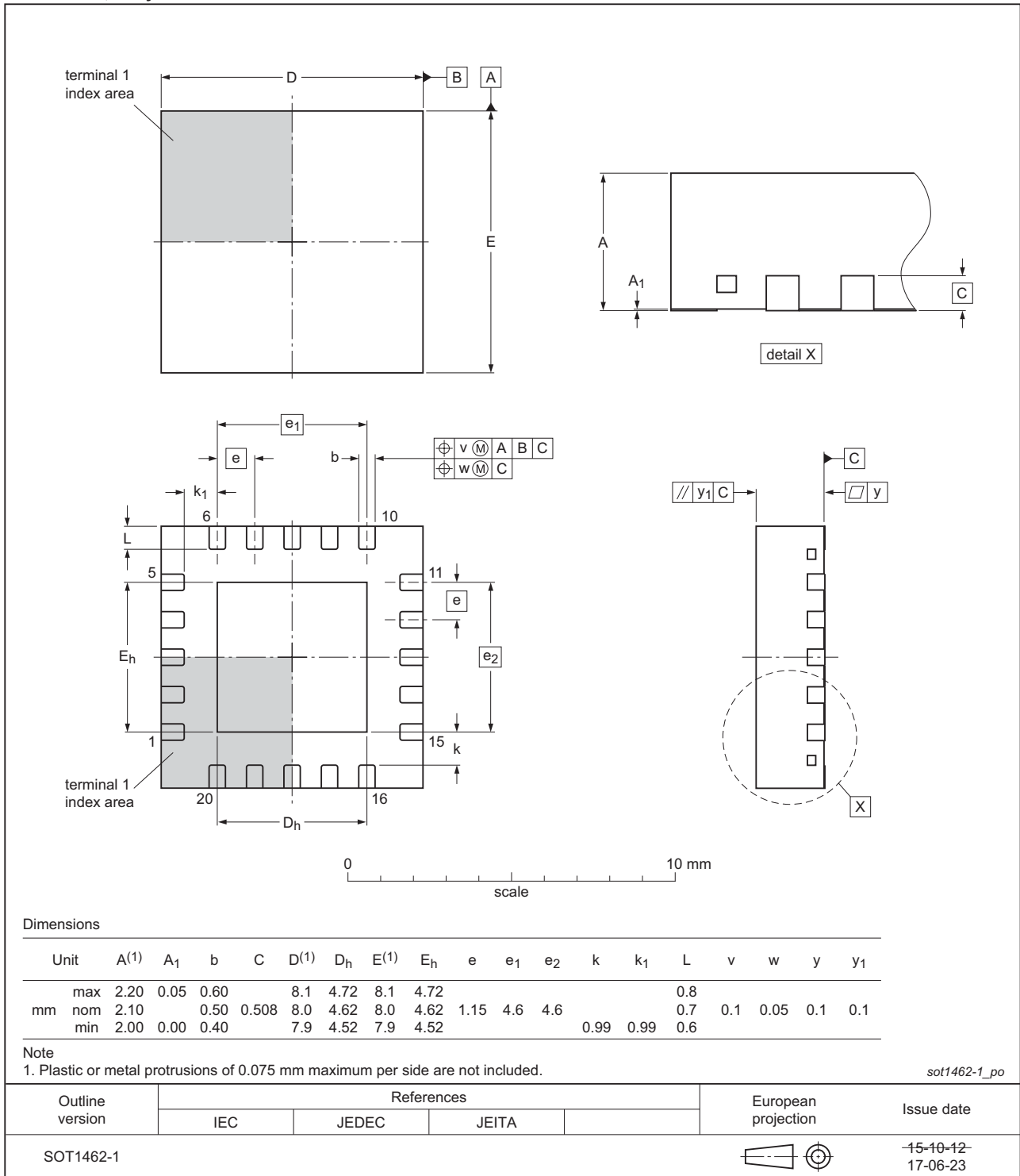

Fig 14. Package outline SOT1462-1 (PQFN20)

## 10. Handling information

**CAUTION**



This device is sensitive to ElectroStatic Discharge (ESD). Observe precautions for handling electrostatic sensitive devices.

Such precautions are described in the *ANSI/ESD S20.20*, *IEC/ST 61340-5*, *JESD625-A* or equivalent standards.

**Table 11. ESD sensitivity**

ESD model	Class
Charged Device Model (CDM); According to ANSI/ESDA/JEDEC standard JS-002	C2B <a href="#">[1]</a>
Human Body Model (HBM); According to ANSI/ESDA/JEDEC standard JS-001	1B <a href="#">[2]</a>

[1] CDM classification C2B is granted to any part that passes after exposure to an ESD pulse of 750 V, but fails after exposure to an ESD pulse of 1000 V.

[2] HBM classification 1B is granted to any part that passes after exposure to an ESD pulse of 500 V, but fails after exposure to an ESD pulse of 1000 V.

## 11. Abbreviations

**Table 12. Abbreviations**

Acronym	Description
3GPP	3rd Generation Partnership Project
CCDF	Complementary Cumulative Distribution Function
CW	Continuous Wave
DPCH	Dedicated Physical CHannel
ESD	ElectroStatic Discharge
GEN9	Ninth Generation
GSM	Global System for Mobile Communications
LDMOS	Laterally Diffused Metal Oxide Semiconductor
LTE	Long Term Evolution
MIMO	Multiple Input Multiple Output
MMIC	Monolithic Microwave Integrated Circuit
MTF	Median Time to Failure
OBO	Output Back Off
PAR	Peak-to-Average Ratio
SMD	Surface Mounted Device
VSWR	Voltage Standing-Wave Ratio
W-CDMA	Wideband Code Division Multiple Access

## 12. Revision history

**Table 13. Revision history**

Document ID	Release date	Data sheet status	Change notice	Supersedes
BLM9D2325-20AB v.1	20170724	Product data sheet	-	-

## 13. Legal information

### 13.1 Data sheet status

Document status <sup>[1][2]</sup>	Product status <sup>[3]</sup>	Definition
Objective [short] data sheet	Development	This document contains data from the objective specification for product development.
Preliminary [short] data sheet	Qualification	This document contains data from the preliminary specification.
Product [short] data sheet	Production	This document contains the product specification.

[1] Please consult the most recently issued document before initiating or completing a design.

[2] The term 'short data sheet' is explained in section "Definitions".

[3] The product status of device(s) described in this document may have changed since this document was published and may differ in case of multiple devices. The latest product status information is available on the Internet at URL <http://www.ampleon.com>.

### 13.2 Definitions

**Draft** — The document is a draft version only. The content is still under internal review and subject to formal approval, which may result in modifications or additions. Ampleon does not give any representations or warranties as to the accuracy or completeness of information included herein and shall have no liability for the consequences of use of such information.

**Short data sheet** — A short data sheet is an extract from a full data sheet with the same product type number(s) and title. A short data sheet is intended for quick reference only and should not be relied upon to contain detailed and full information. For detailed and full information see the relevant full data sheet, which is available on request via the local Ampleon sales office. In case of any inconsistency or conflict with the short data sheet, the full data sheet shall prevail.

**Product specification** — The information and data provided in a Product data sheet shall define the specification of the product as agreed between Ampleon and its customer, unless Ampleon and customer have explicitly agreed otherwise in writing. In no event however, shall an agreement be valid in which the Ampleon product is deemed to offer functions and qualities beyond those described in the Product data sheet.

### 13.3 Disclaimers

**Limited warranty and liability** — Information in this document is believed to be accurate and reliable. However, Ampleon does not give any representations or warranties, expressed or implied, as to the accuracy or completeness of such information and shall have no liability for the consequences of use of such information. Ampleon takes no responsibility for the content in this document if provided by an information source outside of Ampleon.

In no event shall Ampleon be liable for any indirect, incidental, punitive, special or consequential damages (including - without limitation - lost profits, lost savings, business interruption, costs related to the removal or replacement of any products or rework charges) whether or not such damages are based on tort (including negligence), warranty, breach of contract or any other legal theory.

Notwithstanding any damages that customer might incur for any reason whatsoever, Ampleon's aggregate and cumulative liability towards customer for the products described herein shall be limited in accordance with the *Terms and conditions of commercial sale* of Ampleon.

**Right to make changes** — Ampleon reserves the right to make changes to information published in this document, including without limitation specifications and product descriptions, at any time and without notice. This document supersedes and replaces all information supplied prior to the publication hereof.

**Suitability for use** — Ampleon products are not designed, authorized or warranted to be suitable for use in life support, life-critical or safety-critical systems or equipment, nor in applications where failure or malfunction of an

Ampleon product can reasonably be expected to result in personal injury, death or severe property or environmental damage. Ampleon and its suppliers accept no liability for inclusion and/or use of Ampleon products in such equipment or applications and therefore such inclusion and/or use is at the customer's own risk.

**Applications** — Applications that are described herein for any of these products are for illustrative purposes only. Ampleon makes no representation or warranty that such applications will be suitable for the specified use without further testing or modification.

Customers are responsible for the design and operation of their applications and products using Ampleon products, and Ampleon accepts no liability for any assistance with applications or customer product design. It is customer's sole responsibility to determine whether the Ampleon product is suitable and fit for the customer's applications and products planned, as well as for the planned application and use of customer's third party customer(s). Customers should provide appropriate design and operating safeguards to minimize the risks associated with their applications and products.

Ampleon does not accept any liability related to any default, damage, costs or problem which is based on any weakness or default in the customer's applications or products, or the application or use by customer's third party customer(s). Customer is responsible for doing all necessary testing for the customer's applications and products using Ampleon products in order to avoid a default of the applications and the products or of the application or use by customer's third party customer(s). Ampleon does not accept any liability in this respect.

**Limiting values** — Stress above one or more limiting values (as defined in the Absolute Maximum Ratings System of IEC 60134) will cause permanent damage to the device. Limiting values are stress ratings only and (proper) operation of the device at these or any other conditions above those given in the Recommended operating conditions section (if present) or the Characteristics sections of this document is not warranted. Constant or repeated exposure to limiting values will permanently and irreversibly affect the quality and reliability of the device.

**Terms and conditions of commercial sale** — Ampleon products are sold subject to the general terms and conditions of commercial sale, as published at <http://www.ampleon.com/terms>, unless otherwise agreed in a valid written individual agreement. In case an individual agreement is concluded only the terms and conditions of the respective agreement shall apply. Ampleon hereby expressly objects to applying the customer's general terms and conditions with regard to the purchase of Ampleon products by customer.

**No offer to sell or license** — Nothing in this document may be interpreted or construed as an offer to sell products that is open for acceptance or the grant, conveyance or implication of any license under any copyrights, patents or other industrial or intellectual property rights.

**Export control** — This document as well as the item(s) described herein may be subject to export control regulations. Export might require a prior authorization from competent authorities.

**Non-automotive qualified products** — Unless this data sheet expressly states that this specific Ampleon product is automotive qualified, the product is not suitable for automotive use. It is neither qualified nor tested in accordance with automotive testing or application requirements. Ampleon accepts no liability for inclusion and/or use of non-automotive qualified products in automotive equipment or applications.

In the event that customer uses the product for design-in and use in automotive applications to automotive specifications and standards, customer (a) shall use the product without Ampleon's warranty of the product for such automotive applications, use and specifications, and (b) whenever customer uses the product for automotive applications beyond Ampleon's specifications such use shall be solely at customer's own risk, and (c) customer fully indemnifies Ampleon for any liability, damages or failed product claims resulting from customer design and use of the product for automotive applications beyond Ampleon's standard warranty and Ampleon's product specifications.

**Translations** — A non-English (translated) version of a document is for reference only. The English version shall prevail in case of any discrepancy between the translated and English versions.

## 13.4 Trademarks

Notice: All referenced brands, product names, service names and trademarks are the property of their respective owners.

Any reference or use of any 'NXP' trademark in this document or in or on the surface of Ampleon products does not result in any claim, liability or entitlement vis-à-vis the owner of this trademark. Ampleon is no longer part of the NXP group of companies and any reference to or use of the 'NXP' trademarks will be replaced by reference to or use of Ampleon's own trademarks.

## 14. Contact information

---

For more information, please visit: <http://www.ampleon.com>

For sales office addresses, please visit: <http://www.ampleon.com/sales>

**15. Contents**

**1 Product profile . . . . . 1**

1.1 General description . . . . . 1

1.2 Features and benefits . . . . . 1

1.3 Applications . . . . . 1

**2 Pinning information . . . . . 2**

2.1 Pinning . . . . . 2

2.2 Pin description . . . . . 2

**3 Ordering information . . . . . 3**

**4 Block diagram . . . . . 3**

**5 Limiting values . . . . . 3**

**6 Thermal characteristics . . . . . 4**

**7 Characteristics . . . . . 4**

**8 Application information . . . . . 5**

8.1 Ruggedness in a Doherty operation . . . . . 8

8.2 Impedance information . . . . . 8

8.3 Graphs . . . . . 8

**9 Package outline . . . . . 12**

**10 Handling information . . . . . 13**

**11 Abbreviations . . . . . 13**

**12 Revision history . . . . . 13**

**13 Legal information . . . . . 14**

13.1 Data sheet status . . . . . 14

13.2 Definitions . . . . . 14

13.3 Disclaimers . . . . . 14

13.4 Trademarks . . . . . 15

**14 Contact information . . . . . 15**

**15 Contents . . . . . 16**

Please be aware that important notices concerning this document and the product(s) described herein, have been included in section 'Legal information'.

© Ampleon Netherlands B.V. 2017. **All rights reserved.**

For more information, please visit: <http://www.ampleon.com>  
 For sales office addresses, please visit: <http://www.ampleon.com/sales>

Date of release: 24 July 2017  
 Document identifier: BLM9D2325-20AB

## Looking for pricing, stock, or lifecycle information?

Click below to explore more details on WIN SOURCE:

- ⊖ [View BLM9D2325-20ABZ on WIN SOURCE](#)
- ⊖ [Ampleon USA Inc. Information](#)

## Optimize Your Supply Chain with WIN SOURCE Solutions

- ✓ Global Sourcing Solution
- ✓ Obsolete Management
- ✓ Cost Control Management
- ✓ Shortage Management
- ✓ Alternative Solution
- ✓ Excess Inventory Management