



THE DATASHEET OF MRF140



The RF MOSFET Line 150W, to 150MHz, 28V

Rev. V1

Designed primarily for linear large-signal output stages up to 150 MHz frequency range.

N-Channel enhancement mode

- Specified 28 volts, 30 MHz characteristics
Output power = 150 watts
Power gain = 15 dB (Typ.)
Efficiency = 40% (Typ.)
- Superior high order IMD
- IMD_(d3) (150 W PEP): -30 dB (Typ.)
- IMD_(d11) (150 W PEP): -60 dB (Typ.)
- 100% tested for load mismatch at all phase angles with 30:1 VSWR

Product Image

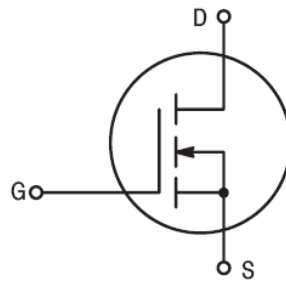
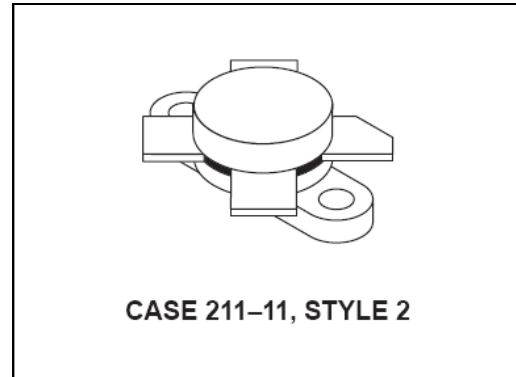

MAXIMUM RATINGS

Rating	Symbol	Value	Unit
Drain-Source Voltage	V_{DSS}	65	Vdc
Drain-Gate Voltage	V_{DGO}	65	Vdc
Gate-Source Voltage	V_{GS}	± 40	Vdc
Drain Current — Continuous	I_D	16	Adc
Total Device Dissipation @ $T_C = 25^\circ\text{C}$ Derate above 25°C	P_D	300 1.7	Watts $\text{W}/^\circ\text{C}$
Storage Temperature Range	T_{stg}	-65 to +150	$^\circ\text{C}$
Operating Junction Temperature	T_J	200	$^\circ\text{C}$

THERMAL CHARACTERISTICS

Characteristic	Symbol	Max	Unit
Thermal Resistance, Junction to Case	$R_{\theta JC}$	0.6	$^\circ\text{C}/\text{W}$

NOTE — **CAUTION** — MOS devices are susceptible to damage from electrostatic charge. Reasonable precautions in handling and packaging MOS devices should be observed.

The RF MOSFET Line 150W, to 150MHz, 28V

Rev. V1

ELECTRICAL CHARACTERISTICS (T_C = 25°C unless otherwise noted.)

Characteristic	Symbol	Min	Typ	Max	Unit
----------------	--------	-----	-----	-----	------

OFF CHARACTERISTICS

Drain–Source Breakdown Voltage (V _{GS} = 0, I _D = 100 mA)	V _{(BR)DSS}	65	—	—	Vdc
Zero Gate Voltage Drain Current (V _{DS} = 28 Vdc, V _{GS} = 0)	I _{DSS}	—	—	5.0	mAdc
Gate–Body Leakage Current (V _{GS} = 20 Vdc, V _{DS} = 0)	I _{GSS}	—	—	1.0	μAdc

ON CHARACTERISTICS

Gate Threshold Voltage (V _{DS} = 10 V, I _D = 100 mA)	V _{GS(th)}	1.0	3.0	5.0	Vdc
Drain–Source On–Voltage (V _{GS} = 10 V, I _D = 10 Adc)	V _{DS(on)}	0.1	0.9	1.5	Vdc
Forward Transconductance (V _{DS} = 10 V, I _D = 5.0 A)	g _{fs}	4.0	7.0	—	mhos

DYNAMIC CHARACTERISTICS

Input Capacitance (V _{DS} = 28 V, V _{GS} = 0, f = 1.0 MHz)	C _{iss}	—	450	—	pF
Output Capacitance (V _{DS} = 28 V, V _{GS} = 0, f = 1.0 MHz)	C _{oss}	—	400	—	pF
Reverse Transfer Capacitance (V _{DS} = 28 V, V _{GS} = 0, f = 1.0 MHz)	C _{rss}	—	75	—	pF

FUNCTIONAL TESTS (SSB)

Common Source Amplifier Power Gain (V _{DD} = 28 V, P _{out} = 150 W (PEP), I _{DQ} = 250 mA)	G _{ps}	— —	15 6.0	— —	dB
Drain Efficiency (V _{DD} = 28 V, P _{out} = 150 W (PEP), f = 30; 30.001 MHz, I _D (Max) = 6.5 A)	η	—	40	—	%
Intermodulation Distortion (1) (V _{DD} = 28 V, P _{out} = 150 W (PEP), f1 = 30 MHz, f2 = 30.001 MHz, I _{DQ} = 250 mA)	IMD _(d3) IMD _(d11)	— —	-30 -60	— —	dB
Load Mismatch (V _{DD} = 28 V, P _{out} = 150 W (PEP), f = 30; 30.001 MHz, I _{DQ} = 250 mA, VSWR 30:1 at all Phase Angles)	ψ	No Degradation in Output Power			

NOTE:

- To MIL–STD–1311 Version A, Test Method 2204B, Two Tone, Reference Each Tone.

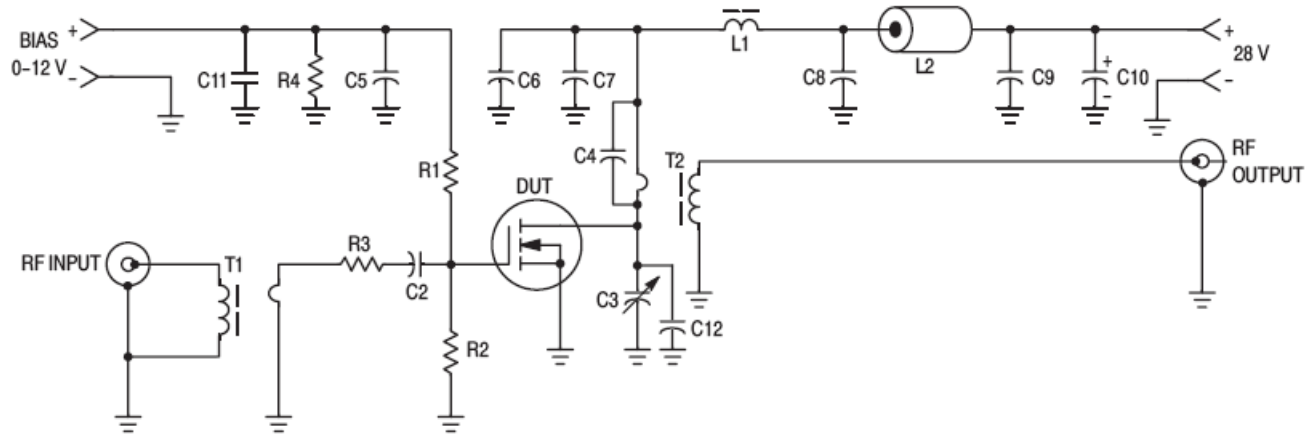

C2, C5, C6, C7, C8, C9 — 0.1 μF Ceramic Chip or Monolithic with Short Leads
 C3 — Arco 469
 C4 — 820 pF Unencapsulated Mica or Dipped Mica with Short Leads
 C10 — 10 μF /100 V Electrolytic
 C11 — 1 μF , 50 V, Tantalum
 C12 — 330 pF, Dipped Mica (Short leads)

L1 — VK200/4B Ferrite Choke or Equivalent, 3.0 μH
 L2 — Ferrite Bead(s), 2.0 μH
 R1, R2 — 51 Ω /1.0 W Carbon
 R3 — 1.0 Ω /1.0 W Carbon or Parallel Two 2 Ω , 1/2 W Resistors
 R4 — 1 k Ω /1/2 W Carbon
 T1 — 16:1 Broadband Transformer
 T2 — 1:25 Broadband Transformer

Figure 1. 30 MHz Test Circuit (Class AB)

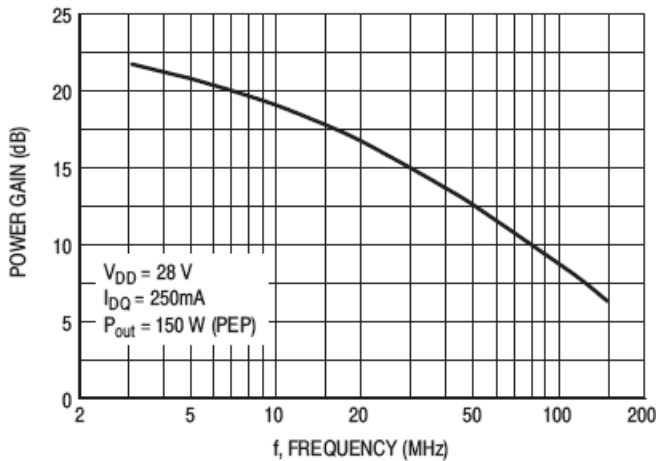

Figure 2. Power Gain versus Frequency

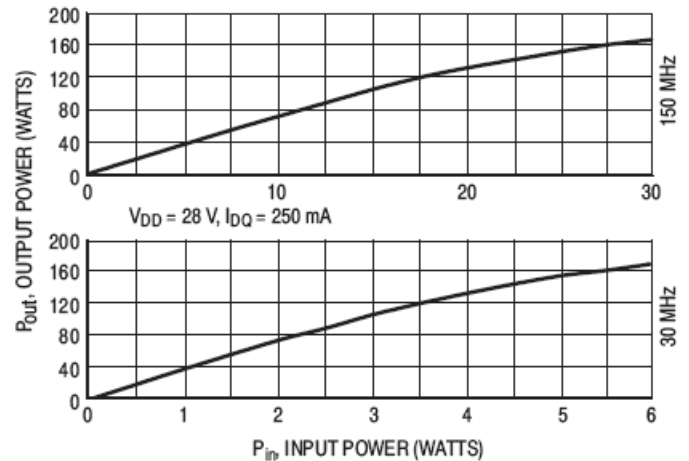

Figure 3. Output Power versus Input Power

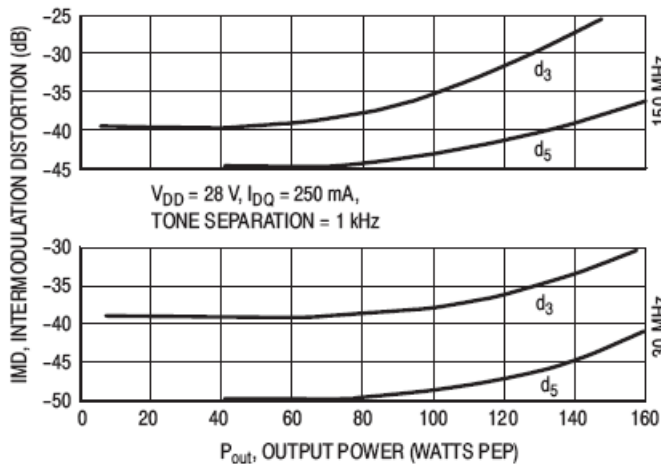

Figure 4. IMD versus P_{out}

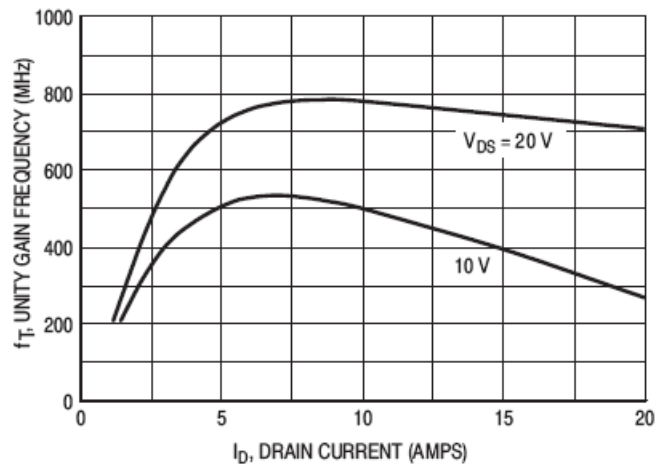

Figure 5. Common Source Unity Gain Frequency versus Drain Current

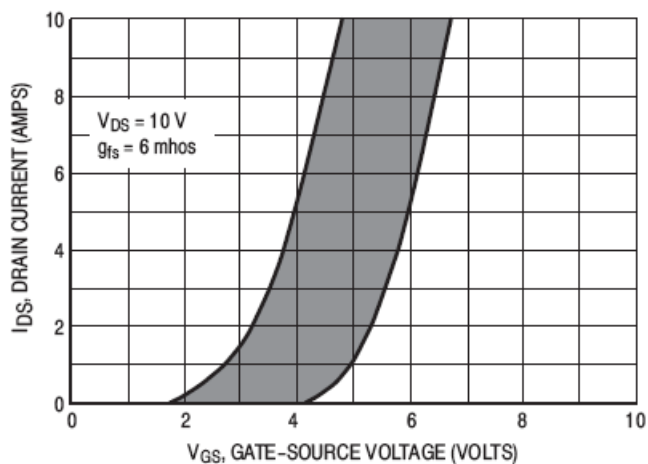
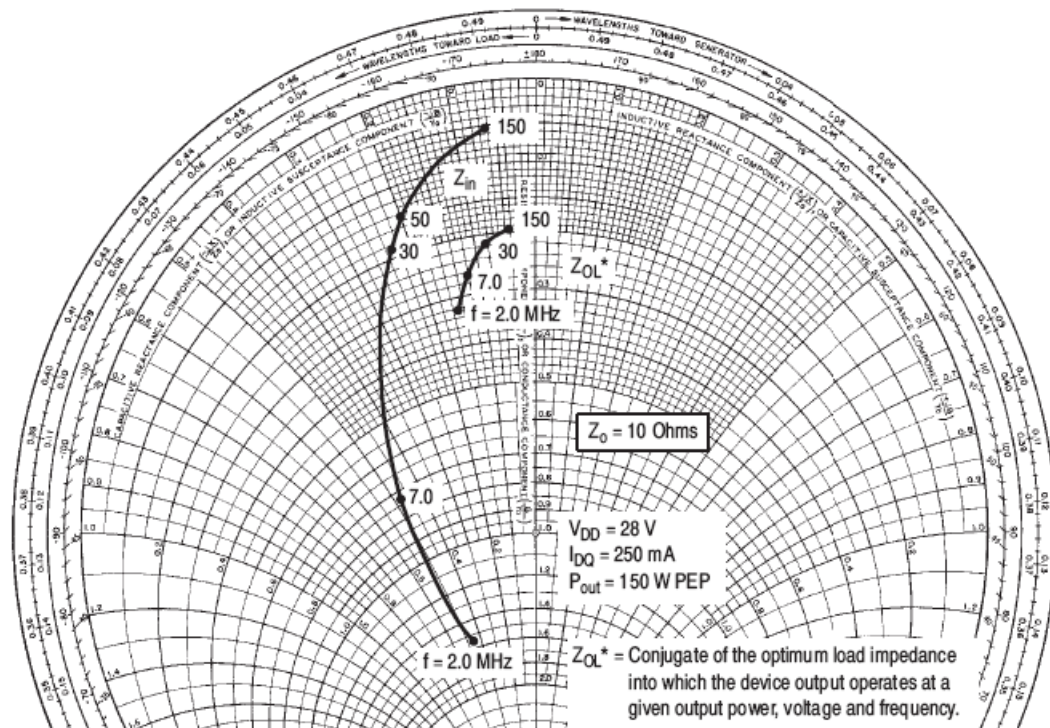
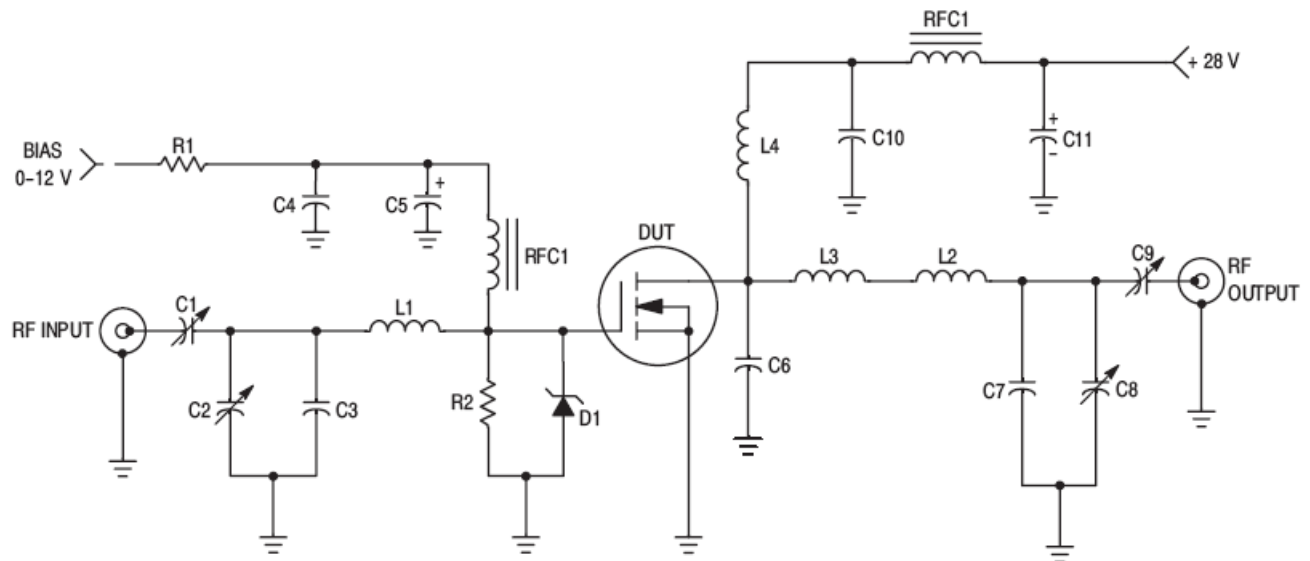

Figure 6. Gate Voltage versus Drain Current



NOTE: Gate Shunted by 25 Ohms.

Figure 7. Series Equivalent Impedance



- C1, C2, C8 — Arco 463 or equivalent
- C3 — 25 pF, Unelco
- C4 — 0.1 μ F, Ceramic
- C5 — 1.0 μ F, 15 WV Tantalum
- C6 — 15 pF, Unelco J101
- C7 — 25 pF, Unelco J101
- C9 — Arco 262 or equivalent
- C10 — 0.05 μ F, Ceramic
- C11 — 15 μ F, 35 WV Electrolytic

- L1 — 3/4", #18 AWG into Hairpin
- L2 — Printed Line, 0.200" x 0.500"
- L3 — 7/8", #16 AWG into Hairpin
- L4 — 2 Turns, #16 AWG, 5/16 ID
- RFC1 — 5.6 μ H, Molded Choke
- RFC2 — VK200-4B
- R1, R2 — 150 Ω , 1.0 W Carbon

Figure 8. 150 MHz Test Circuit (Class AB)

Table 1. Common Source S-Parameters ($V_{DS} = 28\text{ V}$, $I_D = 5\text{ A}$)

f MHz	S ₁₁		S ₂₁		S ₁₂		S ₂₂	
	S ₁₁	∠φ	S ₂₁	∠φ	S ₁₂	∠φ	S ₂₂	∠φ
30	0.957	180	1.88	86	0.008	22	0.938	-178
40	0.956	180	1.46	81	0.010	23	0.940	179
50	0.956	180	1.17	78	0.012	33	0.936	179
60	0.956	179	1.00	76	0.013	44	0.936	177
70	0.957	179	0.86	73	0.012	54	0.960	177
80	0.957	179	0.73	72	0.010	53	0.970	179
90	0.957	179	0.64	71	0.011	45	0.952	180
100	0.957	178	0.58	67	0.015	44	0.934	178
110	0.956	178	0.55	64	0.018	53	0.947	176
120	0.957	178	0.48	64	0.019	67	0.961	177
130	0.957	178	0.43	61	0.017	75	0.973	178
140	0.958	177	0.41	60	0.016	73	0.964	178
150	0.958	177	0.37	59	0.017	60	0.978	179
160	0.957	177	0.36	56	0.023	58	0.934	178
170	0.959	177	0.34	54	0.026	67	0.923	176
180	0.958	177	0.31	51	0.028	75	0.974	175
190	0.958	176	0.30	53	0.026	82	0.986	175
200	0.959	176	0.27	52	0.024	77	0.986	176
210	0.958	176	0.27	54	0.026	67	0.988	177
220	0.960	176	0.28	52	0.032	67	0.951	175
230	0.962	176	0.24	45	0.039	70	1.020	172
240	0.960	176	0.24	44	0.038	76	0.988	171
250	0.962	175	0.21	47	0.038	81	0.980	175
260	0.962	175	0.21	44	0.036	77	0.994	175
270	0.960	175	0.20	44	0.038	72	0.980	173
280	0.963	175	0.20	43	0.043	71	0.962	172
290	0.964	175	0.19	40	0.046	74	0.952	170
300	0.965	175	0.20	42	0.049	78	0.945	170
310	0.966	174	0.18	42	0.046	79	1.010	172
320	0.963	174	0.18	45	0.049	74	0.971	170
330	0.964	174	0.16	42	0.053	74	0.930	170
340	0.966	174	0.18	46	0.055	71	0.947	169

Table 1. Common Source S-Parameters ($V_{DS} = 28\text{ V}$, $I_D = 5\text{ A}$) continued

f MHz	S ₁₁		S ₂₁		S ₁₂		S ₂₂	
	S ₁₁	∠φ	S ₂₁	∠φ	S ₁₂	∠φ	S ₂₂	∠φ
350	0.965	174	0.17	43	0.059	74	0.964	169
360	0.967	173	0.16	43	0.061	74	1.010	167
370	0.968	173	0.15	43	0.063	70	1.010	167
380	0.967	173	0.16	41	0.065	70	0.952	168
390	0.968	173	0.16	45	0.068	72	0.970	168
400	0.968	172	0.15	42	0.069	77	0.957	170
410	0.967	172	0.15	44	0.070	72	1.000	165
420	0.969	172	0.14	43	0.070	68	0.986	164
430	0.968	172	0.13	45	0.078	65	0.980	166
440	0.968	171	0.14	47	0.086	68	0.953	166
450	0.969	171	0.15	45	0.087	74	0.981	166
460	0.968	171	0.14	48	0.076	73	0.971	163
470	0.965	171	0.13	41	0.046	75	0.980	163
480	0.958	170	0.13	40	0.017	115	1.050	162
490	0.954	170	0.13	37	0.041	113	1.050	163
500	0.956	170	0.13	35	0.070	74	1.040	162

RF POWER MOSFET CONSIDERATIONS

MOSFET CAPACITANCES

The physical structure of a MOSFET results in capacitors between the terminals. The metal oxide gate structure determines the capacitors from gate-to-drain (C_{gd}), and gate-to-source (C_{gs}). The PN junction formed during the fabrication of the RF MOSFET results in a junction capacitance from drain-to-source (C_{ds}).

These capacitances are characterized as input (C_{iss}), output (C_{oss}) and reverse transfer (C_{rss}) capacitances on data sheets. The relationships between the inter-terminal capacitances and those given on data sheets are shown below. The

C_{iss} can be specified in two ways:

1. Drain shorted to source and positive voltage at the gate.
2. Positive voltage of the drain in respect to source and zero volts at the gate. In the latter case the numbers are lower. However, neither method represents the actual operating conditions in RF applica-

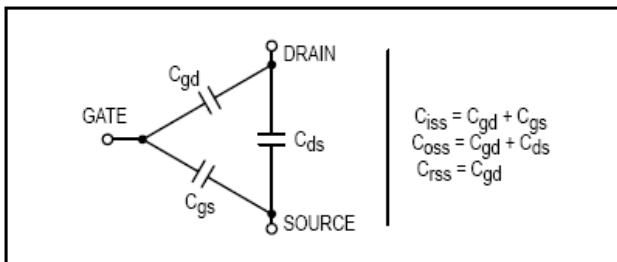

tions.

LINEARITY AND GAIN CHARACTERISTICS

In addition to the typical IMD and power gain data presented, Figure 5 may give the designer additional information on the capabilities of this device. The graph represents the small signal unity current gain frequency at a given drain current level. This is equivalent to f_T for bipolar transistors. Since this test is performed at a fast sweep speed, heating of the device does not occur. Thus, in normal use, the higher temperatures may degrade these characteristics to some extent.

GATE CHARACTERISTICS

The gate of the RF MOSFET is a polysilicon material, and is electrically isolated from the source by a layer of oxide. The input resistance is very high — on the order of 109 ohms

— resulting in a leakage current of a few nanoamperes.

Gate control is achieved by applying a positive voltage slightly in excess of the gate-to-source threshold voltage, $V_{GS(th)}$.

Gate Voltage Rating — Never exceed the gate voltage rating. Exceeding the rated V_{GS} can result in permanent damage to the oxide layer in the gate region.

Gate Termination — The gates of these devices are essentially capacitors. Circuits that leave the gate open-circuited or floating should be avoided. These conditions can result in turn-on of the devices due to voltage build-up on the input capacitor due to leakage currents or pickup.

Gate Protection — These devices do not have an internal monolithic zener diode from gate-to-source. If gate protection is required, an external zener diode is recommended.

EQUIVALENT TRANSISTOR PARAMETER TERMINOLOGY

Collector	Drain
Emitter	Source
Base	Gate
$V_{(BR)CES}$	$V_{(BR)DSS}$
V_{CBO}	V_{DGO}
I_C	I_D
I_{CES}	I_{DSS}
I_{EBO}	I_{GSS}
$V_{BE(on)}$	$V_{GS(th)}$
$V_{CE(sat)}$	$V_{DS(on)}$
C_{ib}	C_{iss}
C_{ob}	C_{oss}
h_{fe}	g_{fs}
$R_{CE(sat)} = \frac{V_{CE(sat)}}{I_C}$	$r_{DS(on)} = \frac{V_{DS(on)}}{I_D}$

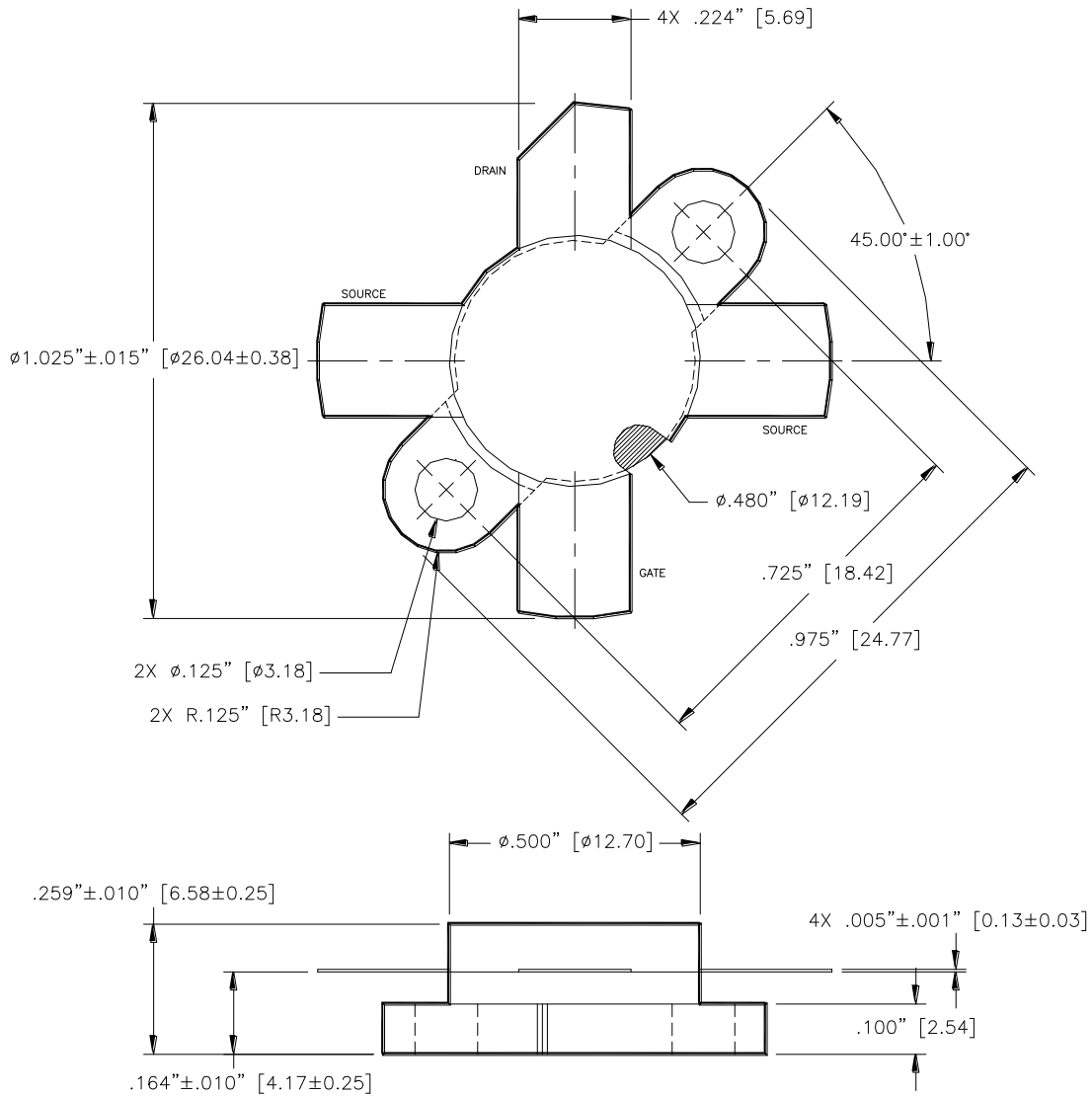

Unless otherwise noted, tolerances are inches $\pm .005$ [millimeters ± 0.13 mm]

M/A-COM Technology Solutions Inc. All rights reserved.

Information in this document is provided in connection with M/A-COM Technology Solutions Inc ("MACOM") products. These materials are provided by MACOM as a service to its customers and may be used for informational purposes only. Except as provided in MACOM's Terms and Conditions of Sale for such products or in any separate agreement related to this document, MACOM assumes no liability whatsoever. MACOM assumes no responsibility for errors or omissions in these materials. MACOM may make changes to specifications and product descriptions at any time, without notice. MACOM makes no commitment to update the information and shall have no responsibility whatsoever for conflicts or incompatibilities arising from future changes to its specifications and product descriptions. No license, express or implied, by estoppel or otherwise, to any intellectual property rights is granted by this document.

THESE MATERIALS ARE PROVIDED "AS IS" WITHOUT WARRANTY OF ANY KIND, EITHER EXPRESS OR IMPLIED, RELATING TO SALE AND/OR USE OF MACOM PRODUCTS INCLUDING LIABILITY OR WARRANTIES RELATING TO FITNESS FOR A PARTICULAR PURPOSE, CONSEQUENTIAL OR INCIDENTAL DAMAGES, MERCHANTABILITY, OR INFRINGEMENT OF ANY PATENT, COPYRIGHT OR OTHER INTELLECTUAL PROPERTY RIGHT. MACOM FURTHER DOES NOT WARRANT THE ACCURACY OR COMPLETENESS OF THE INFORMATION, TEXT, GRAPHICS OR OTHER ITEMS CONTAINED WITHIN THESE MATERIALS. MACOM SHALL NOT BE LIABLE FOR ANY SPECIAL, INDIRECT, INCIDENTAL, OR CONSEQUENTIAL DAMAGES, INCLUDING WITHOUT LIMITATION, LOST REVENUES OR LOST PROFITS, WHICH MAY RESULT FROM THE USE OF THESE MATERIALS.

MACOM products are not intended for use in medical, lifesaving or life sustaining applications. MACOM customers using or selling MACOM products for use in such applications do so at their own risk and agree to fully indemnify MACOM for any damages resulting from such improper use or sale.

Looking for pricing, stock, or lifecycle information?

Click below to explore more details on WIN SOURCE:

- ⊖ [View MRF140 on WIN SOURCE](#)
- ⊖ [M/A-Com Technology Solutions Information](#)

Optimize Your Supply Chain with WIN SOURCE Solutions

- ✓ Global Sourcing Solution
- ✓ Obsolete Management
- ✓ Cost Control Management
- ✓ Shortage Management
- ✓ Alternative Solution
- ✓ Excess Inventory Management