



# MRF421



## The RF Line NPN Silicon Power Transistor 100W(PEP), 30MHz, 28V

M/A-COM Products  
Released - Rev. 07.07

Designed primarily for application as a high-power linear amplifier from 2.0 to 30 MHz.

### Product Image

- Specified 12.5 V, 30 MHz characteristics —  
Output power = 100 W (PEP)  
Minimum gain = 10 dB  
Efficiency = 40%
- Intermodulation distortion @ 100 W (PEP) — IMD = -30 dB (min.)
- 100% tested for load mismatch at all phase angles with 30:1 VSWR

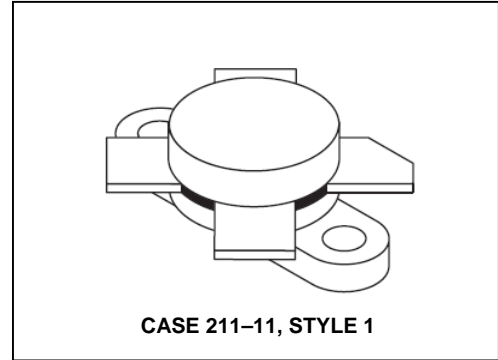

### MAXIMUM RATINGS

Rating	Symbol	Value	Unit
Collector-Emitter Voltage	$V_{CEO}$	20	Vdc
Collector-Base Voltage	$V_{CBO}$	45	Vdc
Emitter-Base Voltage	$V_{EBO}$	3.0	Vdc
Collector Current — Continuous	$I_C$	20	Adc
Withstand Current — 10 s	—	30	Adc
Total Device Dissipation @ $T_C = 25^\circ\text{C}$ Derate above $25^\circ\text{C}$	$P_D$	290 1.66	Watts $\text{W}/^\circ\text{C}$
Storage Temperature Range	$T_{stg}$	-65 to +150	$^\circ\text{C}$

### THERMAL CHARACTERISTICS

Characteristic	Symbol	Max	Unit
Thermal Resistance, Junction to Case	$R_{\theta JC}$	0.6	$^\circ\text{C}/\text{W}$

### ELECTRICAL CHARACTERISTICS ( $T_C = 25^\circ\text{C}$ unless otherwise noted.)

Characteristic	Symbol	Min	Typ	Max	Unit
----------------	--------	-----	-----	-----	------

### OFF CHARACTERISTICS

Collector-Emitter Breakdown Voltage ( $I_C = 50 \text{ mAdc}$ , $I_B = 0$ )	$V_{(BR)CEO}$	20	—	—	Vdc
Collector-Emitter Breakdown Voltage ( $I_C = 200 \text{ mAdc}$ , $V_{BE} = 0$ )	$V_{(BR)CES}$	45	—	—	Vdc
Collector-Base Breakdown Voltage ( $I_C = 200 \text{ mAdc}$ , $I_E = 0$ )	$V_{(BR)CBO}$	45	—	—	Vdc
Emitter-Base Breakdown Voltage ( $I_E = 10 \text{ mAdc}$ , $I_C = 0$ )	$V_{(BR)EBO}$	3.0	—	—	Vdc
Collector Cutoff Current ( $V_{CE} = 16 \text{ Vdc}$ , $V_{BE} = 0$ , $T_C = 25^\circ\text{C}$ )	$I_{CES}$	—	—	10	mAdc

(continued)

## The RF Line NPN Silicon Power Transistor 100W(PEP), 30MHz, 28V

M/A-COM Products  
Released - Rev. 07.07

### ELECTRICAL CHARACTERISTICS – continued ( $T_C = 25^\circ\text{C}$ unless otherwise noted.)

Characteristic	Symbol	Min	Typ	Max	Unit
<b>ON CHARACTERISTICS</b>					
DC Current Gain ( $I_C = 5.0 \text{ Adc}$ , $V_{CE} = 5.0 \text{ Vdc}$ )	$h_{FE}$	10	70	—	—
<b>DYNAMIC CHARACTERISTICS</b>					
Output Capacitance ( $V_{CB} = 12.5 \text{ Vdc}$ , $I_E = 0$ , $f = 1.0 \text{ MHz}$ )	$C_{ob}$	—	550	800	pF
<b>FUNCTIONAL TESTS</b>					
Common-Emitter Amplifier Power Gain ( $V_{CC} = 12.5 \text{ Vdc}$ , $P_{out} = 100 \text{ W}$ , $I_{C(max)} = 10 \text{ Adc}$ , $I_{CQ} = 150 \text{ mA}$ , $f = 30, 30.001 \text{ MHz}$ )	$G_{PE}$	10	12	—	dB
Collector Efficiency ( $V_{CC} = 12.5 \text{ Vdc}$ , $P_{out} = 100 \text{ W}$ , $I_{C(max)} = 10 \text{ Adc}$ , $I_{CQ} = 150 \text{ mA}$ , $f = 30, 30.001 \text{ MHz}$ )	$\eta$	40	—	—	%
Intermodulation Distortion (1) ( $V_{CE} = 12.5 \text{ Vdc}$ , $P_{out} = 100 \text{ W}$ , $I_C = 10 \text{ Adc}$ , $I_{CQ} = 150 \text{ mA}$ , $f = 30, 30.001 \text{ MHz}$ )	IMD	—	-33	-30	dB

**NOTE:**

- To proposed EIA method of measurement. Reference peak envelope power.

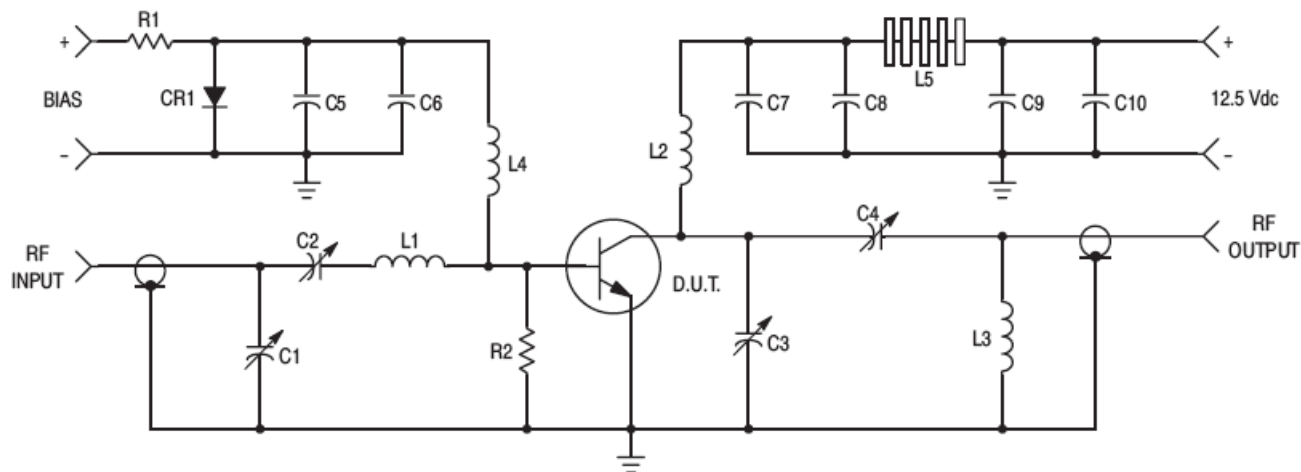

C1, C2, C4 — 170–780 pF, ARCO 469  
 C3 — 80–480 pF, ARCO 466  
 C5, C7, C10 — ERIE 0.1  $\mu\text{F}$ , 100 V  
 C6 — MALLORY 500  $\mu\text{F}$  @ 15 V Electrolytic  
 C9 — 100  $\mu\text{F}$ , 15 V Electrolytic  
 C8 — 1000 pF, 350 V UNDERWOOD  
 R1 — 10  $\Omega$ , 25 Watt Wirewound

R2 — 10  $\Omega$ , 1.0 Watt Carbon  
 CR1 — 1N4997  
 L1 — 3 Turns, #16 Wire, 5/16" I.D., 5/16" Long  
 L2 — 12 Turns, #16 Enameled Wire Closewound, 1/4" I.D.  
 L3 — 1–3/4 Turns, 1/8" Tubing, 3/8" I.D., 3/8" Long  
 L4 — 10  $\mu\text{H}$  Molded Choke  
 L5 — 10 Ferrite Beads — FERROXCUBE #56–590–65/3B

**Figure 1. 30 MHz Test Circuit Schematic**

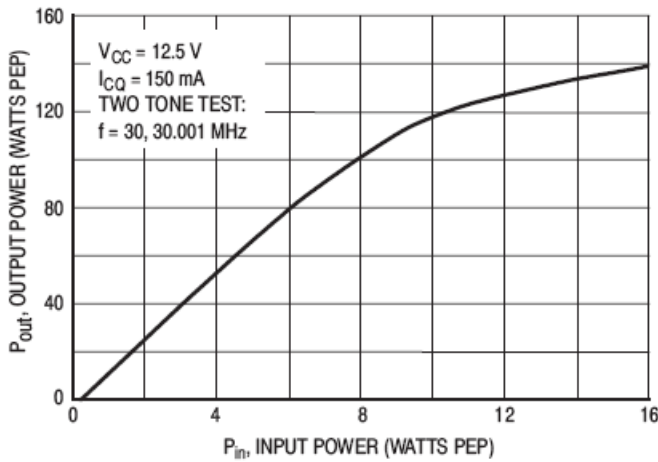

Figure 2. Output Power versus Input Power

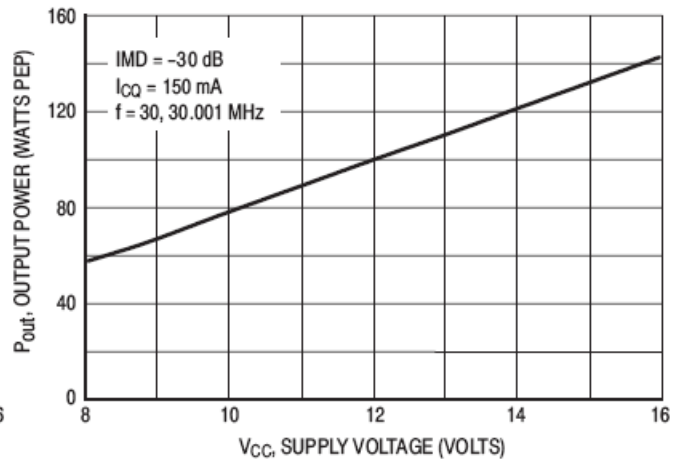

Figure 3. Output Power versus Supply Voltage

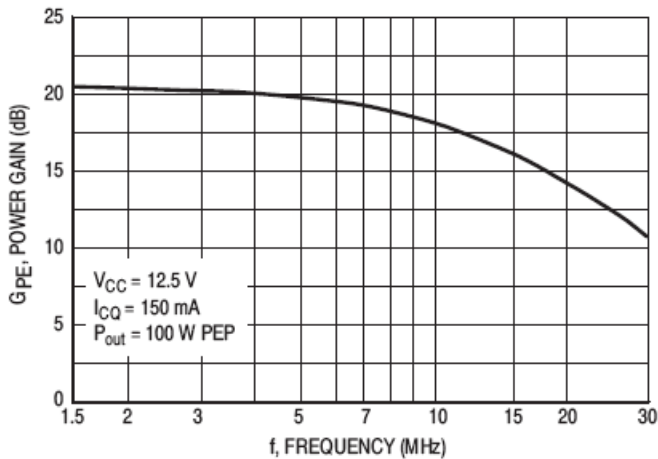

Figure 4. Power Gain versus Frequency

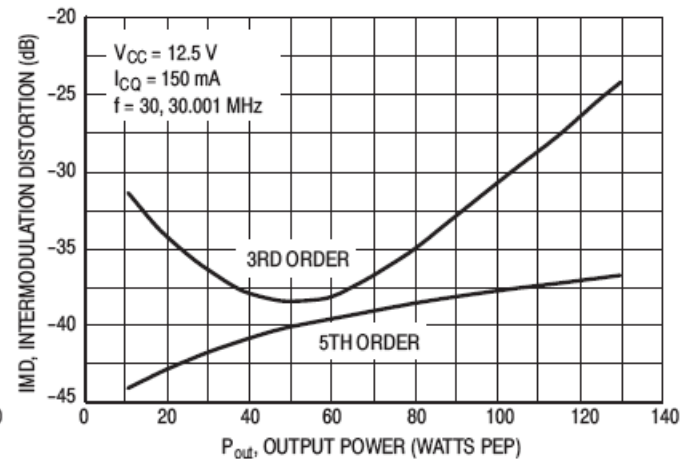

Figure 5. Intermodulation Distortion versus Output Power

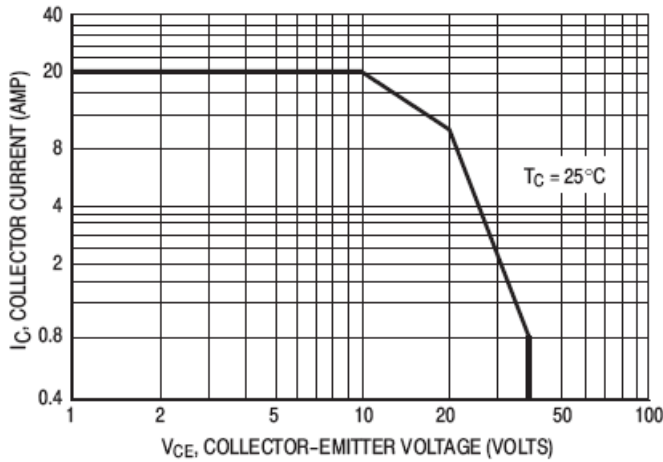

Figure 6. DC Safe Operating Area

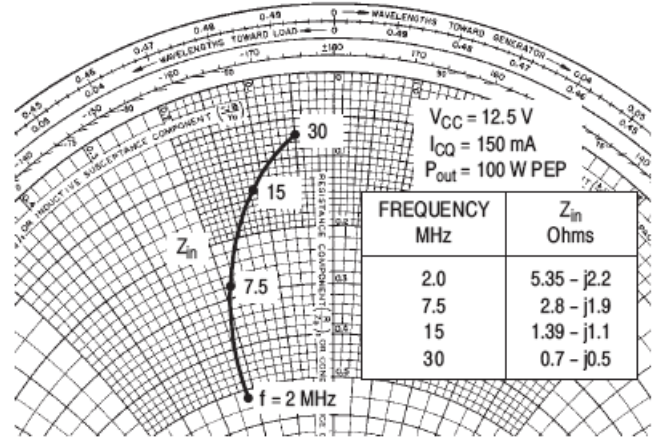

Figure 7. Series Equivalent Impedance

## The RF Line NPN Silicon Power Transistor 100W(PEP), 30MHz, 28V

M/A-COM Products  
Released - Rev. 07.07

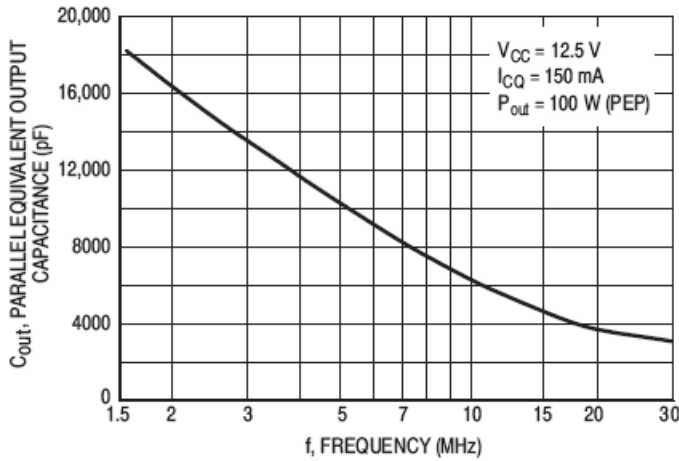

Figure 8. Output Capacitance versus Frequency

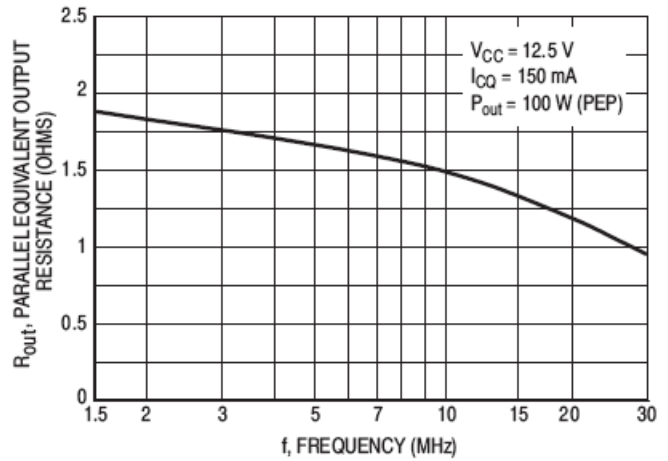
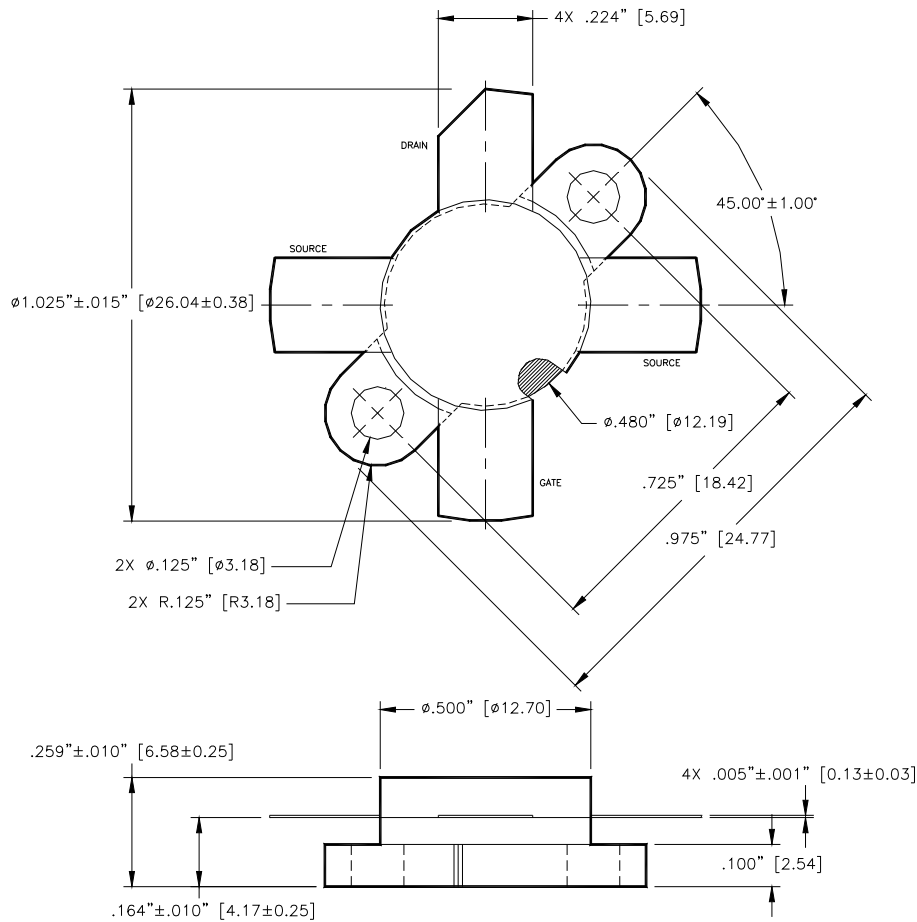

Figure 9. Output Resistance versus Frequency



Unless otherwise noted, tolerances are inches  $\pm 0.005$  [millimeters  $\pm 0.13$ mm]

**ADVANCED:** Data Sheets contain information regarding a product M/A-COM Technology Solutions is considering for development. Performance is based on target specifications, simulated results, and/or prototype measurements. Commitment to develop is not guaranteed.  
**PRELIMINARY:** Data Sheets contain information regarding a product M/A-COM Technology Solutions has under development. Performance is based on engineering tests. Specifications are typical. Mechanical outline has been fixed. Engineering samples and/or test data may be available. Commitment to produce in volume is not guaranteed.

- **North America** Tel: 800.366.2266 / Fax: 978.366.2266
- **Europe** Tel: 44.1908.574.200 / Fax: 44.1908.574.300
- **Asia/Pacific** Tel: 81.44.844.8296 / Fax: 81.44.844.8298

Visit [www.macomtech.com](http://www.macomtech.com) for additional data sheets and product information.

M/A-COM Technology Solutions Inc. and its affiliates reserve the right to make changes to the product(s) or information contained herein without notice.

## Looking for pricing, stock, or lifecycle information?

Click below to explore more details on WIN SOURCE:

- ⊖ [View MRF421 on WIN SOURCE](#)
- ⊖ [M/A-Com Technology Solutions Information](#)

## Optimize Your Supply Chain with WIN SOURCE Solutions

- ✓ Global Sourcing Solution
- ✓ Obsolete Management
- ✓ Cost Control Management
- ✓ Shortage Management
- ✓ Alternative Solution
- ✓ Excess Inventory Management